



DEXTER[®]
LAUNDRY











O-Series OPL Express Plus Washers
WN0675, WN0975, & WN1475
(Express Plus Washers 400G)

Parts & Service Manual

Equipment Safety Warnings

Symbols and Terminology Used in this Equipment

	<p>Indicates an imminently hazardous situation, which if not avoided, will result in death or serious injury.</p>
	<p>Indicates a potentially hazardous situation, which if not avoided could result in death or serious injury.</p>
	<p>Indicates a potentially hazardous situation which, if not avoided, may result in minor or moderate injury. It may also be used to alert against unsafe practices. Minor burns, pinch points that result in bruises and minor chemical irritation.</p>
	<p>Indicates information or a company policy that relates directly or indirectly to the safety of personnel or protection of property.</p>
	<p>This is the user caution symbol. It indicates a condition where damage to the equipment resulting in injury to the operator could occur if operational procedures are not followed. TO REDUCE THE RISK OF DAMAGE OR INJURY, refer to accompanying documents; follow all steps or procedures as instructed.</p>
	<p>This is the electrical hazard symbol. It indicates that there are DANGEROUS HIGH VOLTAGES PRESENT inside the enclosure of this product. TO REDUCE THE RISK OF FIRE OR ELECTRIC SHOCK, do not attempt to open the enclosure or gain access to areas where you are not instructed to do so. REFER SERVICING TO QUALIFIED SERVICE PERSONNEL ONLY</p>
	<p>Caution! There are sharp edges on various sheet metal parts internal to the enclosure. Use safety consciousness when placing or moving your hands while working in the interior of this equipment.</p>
	<p>Caution! To reduce the risk of damage to the Water Inlet Valve, do not supply inlet water with a temperature that exceeds 70° C.</p> <p>Caution! To reduce the risk of fire or explosion, do not operate this equipment in any hazardous classified (ATEX) environment.</p>

Equipment Safety Warnings

Symbols and Terminology Used in this Equipment



Warning! Do not operate equipment if door glass is damaged in any way.



Warning! Keep clear of rotating parts.



Prohibited! Do not enter this equipment or space.



Prohibited! Do not step or stand on this equipment.



Prohibited! Do not operate without all guards and covers in place.









Prohibited! Do not operate without all guards and covers in place.



Prohibited! Do not wash clothing impregnated with flammable liquids (petrochemical).







Prohibited! Do not allow children to play in or around equipment.

	<p>Indicates an imminently hazardous situation, which if not avoided, <u>will result</u> in death or serious injury.</p>
	<p>Indicates a potentially hazardous situation, which if not avoided <u>could result</u> in death or serious injury.</p>
	<p>Indicates a potentially hazardous situation which, if not avoided, <u>may result</u> in minor or moderate injury. It may also be used to alert against unsafe practices. Minor burns, pinch points that result in bruises and minor chemical irritation.</p>
	<p>Indicates information or a company policy that relates directly or indirectly to the safety of personnel or protection of property.</p>
	<p>This is the user caution symbol. It indicates a condition where damage to the equipment resulting in injury to the operator could occur if operational procedures are not followed. TO REDUCE THE RISK OF DAMAGE OR INJURY, refer to accompanying documents; follow all steps or procedures as instructed.</p>
	<p>This is the electrical hazard symbol. It indicates that there are DANGEROUS HIGH VOLTAGES PRESENT inside the enclosure of this product. TO REDUCE THE RISK OF FIRE OR ELECTRIC SHOCK, do not attempt to open the enclosure or gain access to areas where you are not instructed to do so. REFER SERVICING TO QUALIFIED SERVICE PERSONNEL ONLY.</p>
	<p>Caution! To reduce the risk of fire or explosion, do not operate this equipment in any hazardous classified (ATEX) environment.</p>



WARNING

	<ul style="list-style-type: none">• All washers must be installed in accordance to all applicable electrical, plumbing and all other local codes.• These installation and operation instructions are for use by qualified personnel only. To avoid injury and electrical shock, do not perform any servicing other than that contained in the installation and operation instructions, unless qualified.
	<p>Do not install washers in an explosive atmosphere.</p>
	<ul style="list-style-type: none">• Care must be stressed with all foundation work to ensure a stable unit installation, eliminating possibilities of excessive vibration.• Foundation must be level within 13 mm to ensure proper washer operation.
	<p>Do not operate washer if door glass is damaged in any way.</p>
	<p>Do not wash clothing impregnated with flammable liquids (petrochemical).</p>



WARNING







	Children should be supervised to ensure they do not operate or play in or around equipment.
	Keep all panels in place to protect against electrical shock and injury and add rigidity to washer.

This appliance is not intended for use by persons (including children) with reduced physical, sensory or mental capabilities, or lack of experience and knowledge, unless they have been given supervision or instruction concerning use of the appliance by a person responsible for their safety.

A washer should not be allowed to operate if any of the following occur:

- Excessive high water level.
- Machine is not connected to a properly earthed circuit.
- Door does not remain securely locked during the entire cycle.
- Vibration or shaking from an inadequate mounting or foundation

	<p>Warning! Do not operate equipment if door glass is damaged in any way.</p>
	<p>Warning! Keep clear of rotating parts.</p>
	<p>Prohibited! Do not enter this equipment or space.</p>
	<p>Prohibited! Do not step or stand on this equipment.</p>
	<p>Prohibited! Do not operate without all guards and covers in place.</p>
	<p>Prohibited! Do not operate without all guards and covers in place.</p>
	<p>Prohibited! Do not wash clothing impregnated with flammable liquids (petrochemical).</p>
	<p>Prohibited! Do not allow children to play in or around equipment.</p>

	<p>Prohibited! Do not attempt to open, touch, or proceed before referring to the manual or unless qualified.</p>
	<p>Mandatory! Read all supporting documentation before operating or maintaining equipment.</p>
	<p>Mandatory! Disconnect power before servicing equipment.</p>
	<p>Mandatory! Lock out and tag out before servicing this equipment.</p>
	<p>Mandatory! Disconnect water supply before servicing equipment.</p>
	<p>Mandatory! Children should be supervised to ensure they do not operate equipment.</p>

Dexter Safety Guidelines

Table of Contents



WARNING

These washers are equipped with devices and features relating to their safe operation. To avoid injury or electrical shock, do not perform and service, unless qualified to do so.

FOR SAFETY

1. Always shut off power and water supply and also discharge capacitors before servicing.
2. Do not overload the washer.
3. Do not attempt to open door if cylinder is in motion or contains water.
4. Do not mechanically force or override door lock in any way.
5. Do not bypass any safety devices of this washer.
6. Do not use volatile or flammable substances in or near this washer.
7. Keep all panels in place. They protect against shock and injury and add rigidity to the washer.

A machine should not be allowed to operated if any of the following occur:

- Excessively high water level.
- Machine is not connected to a properly grounded circuit.
- Loading door does not remain securely locked during the entire cycle.
- Vibration or shaking from an inadequate mounting or foundation.

To activate your warranty, be sure to return your red warranty form to the factory. Please have serial number and model ready when calling for assistance.

Section 1: Machine Mounting & Installation

T-675	14
T-975	15
T-1475.....	15
T-675 Installation.....	16
T-975 Installation.....	17
T-1975 Installation	18

Section 2: Machine Installation & Operating Instructions

Basic Installation	22-26
Electrical Connections & Fusing Requirements... 27 - 28	
Machine Chemical Connection	29
Emergency Stop Button.....	31
Detergent Measurements by Model	32

Section 3: Machine Programming Instructions

Programming	36-44
-------------------	-------

Section 4: Trouble Shooting

Common Troubleshooting Solutions Pages	45-48
Troubleshooting Machine Fault Errors Pages	49-52
Motor Resistance Chart.....	53

Section 5: Machine Service Procedures

Top Panel Removal.....	56
Front Panel Removal	56
Back Panel Removal.....	56
Drain Valve Access.....	56
Drain Valve Cleaning	56
Detergent Dispenser.....	56
Vacuum Breaker / Air Gap.....	57
Water Valves	57

Door Lock Assembly Operation.....	57	Wash Circuit.....	75
Adjustment for the Door Lock		Drain, Rinse 1 & 2 & Final Rinse Circuit.....	76
Assembly.....	57-58	Extract Circuit.....	76
Adjusting the Loading Door	59	Thermoactuator and Shake Out Circuit.....	76
Loading Door Removal	59	End of Cycle Circuit	76
Loading Door Hinge Removal	59	Diagrams & Schematics	78-83
Loading Door Disassembly.....	60		
Loading Door Reassembly	60	Section 8:	
Control Panel Name Plate Decal.....	60	Parts Data	
Name Plate Removal	60	O-Series Accessories	86
Re-Installation of Name Plate.....	60	Wiring Harness Part # by Model	87
Door Locking Motor	61	Cabinet and Front Panel Group Part #	
Thermoactuators.....	61	by Model	88-89
Lock Thermoactuator.....	61	Soap Dish.....	90-92
Unlock Thermoactuator	61	Rear View Access Part # by Model.....	93-94
Drive Belt Removal	61	Rear Channel	95-96
Tub Back, Bearing and Cylinder Assembly	62-64	Cylinder, Seals & Bearings Part #	
Basket Pulley, Bearing Housing,		by Model	97-98
Water Seals & Tub Back	62-64	Door Lock Part # by Model.....	99-100
T-650, T-750, T-950, & T-1450		Loading Door Part # by Model	101-102
Bolt Torque Chart.....	65	Water Inlet Part # by Model.....	103-104
		Water Inlet Valve Breakdown	105-106
Section 6:		Drain Valve Group Part # by Model.....	107
Control Mounting Trough	68	Chassis and Drain Part # by Model.....	108-109
Main Data Communication Cable	68	Electrical Components -	
Circuit Breaker/Fuse	68	Top Compartment.....	110-111
Main Control Printed Circuit Board.....	68	Control Panel Part # by Model	112-113
PCB Transformer Step Down	68	Labels and Diagrams All Models.....	114
Controls Transformer.....	68		
Main Relay Printed Circuit Board	68	Section 9:	
Pressure Switch.....	68	50 Hz Models	
LED Printed Circuit Board Temperature & Start/		-39 Pats.....	125-128
Display Push Button.....	68	50HZ Diagrams & Schematics.....	130-137
Power Connection Terminal Block	69		
Delta Variable Frequency Drive.....	69	Section 10:	
Delta VFD Motor Leads	69	Electric Heated 60 Hz Models	
Delta VFD Dynamic Braking Resistors	69	-13 Parts.....	139-141
Delta VFD Cooling Fan.....	69	Diagrams & Schematics.....	142-145
Section 7:			
Machine Electrical & Wiring Schematics			
Start Circuit	74		
Fill Circuit.....	75		

Section 11:

Electric Heated 50 Hz Models

-68 Parts.....147-149

Diagrams & Schematics.....150-153

Section 12:

Maintenance

Preventative Maintenance.....156



Section 1:

Machine Mounting

Specifications for below models are outlined in this book:

T-675	WN0675XB-12EO	208-240 volts 60hz	Single Phase or Three Phase
T-975	WN0975XB-12EO	208-240 volts 60hz	Single Phase or Three Phase
T-1475	WN1475XB-12EO	208-240 volts 60hz	Single Phase or Three Phase

T-675 Machine Dimensions

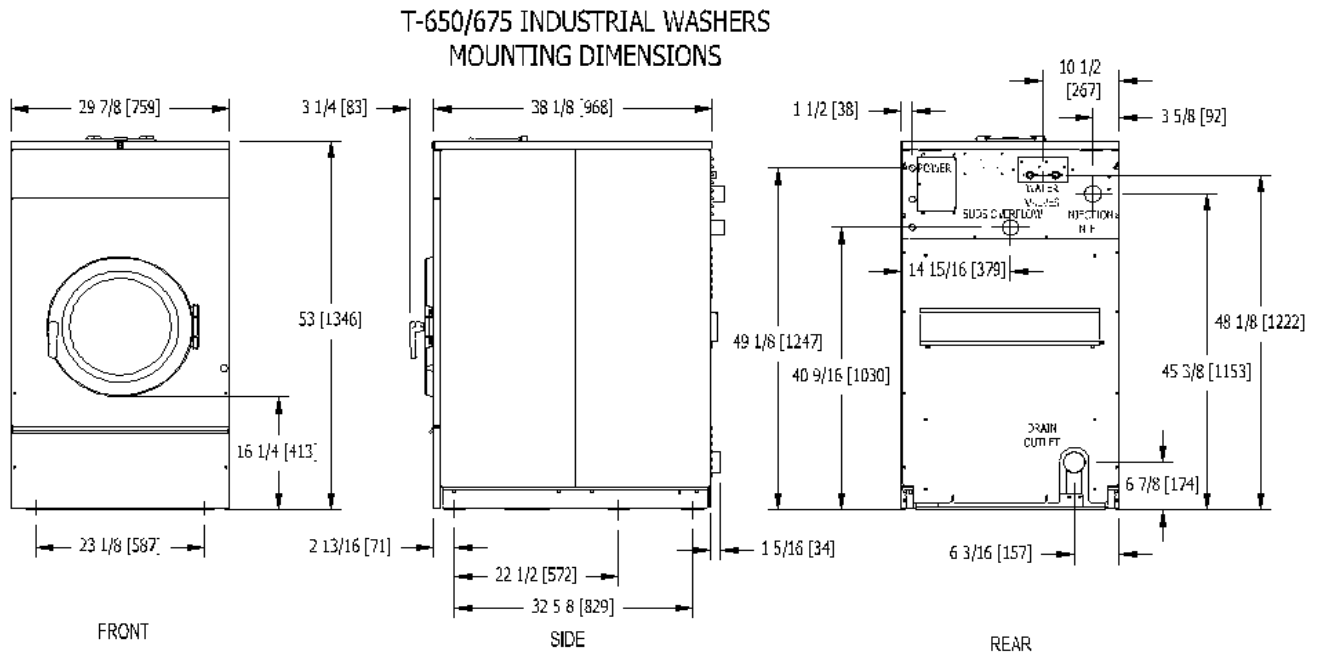

T-975 Machine Dimensions

T-950/975 INDUSTRIAL WASHERS
MOUNTING DIMENSIONS

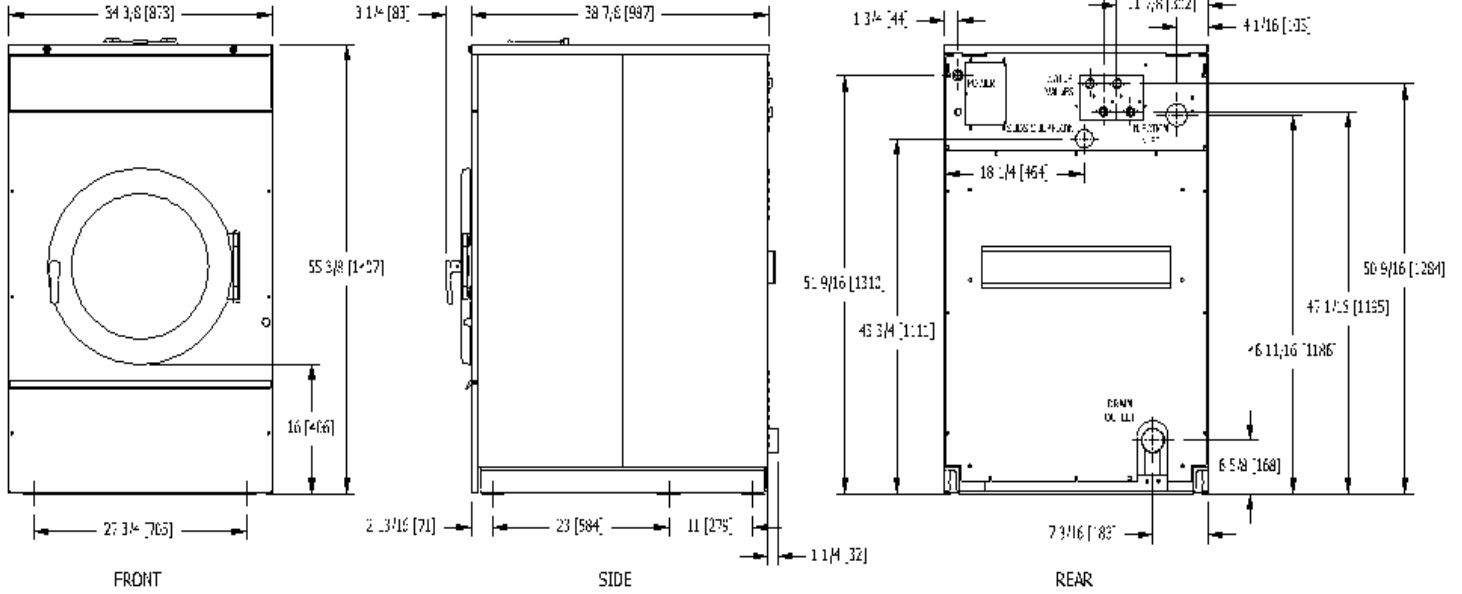

T-1475 Machine Dimensions

T-1450/1475 INDUSTRIAL WASHERS
MOUNTING DIMENSIONS

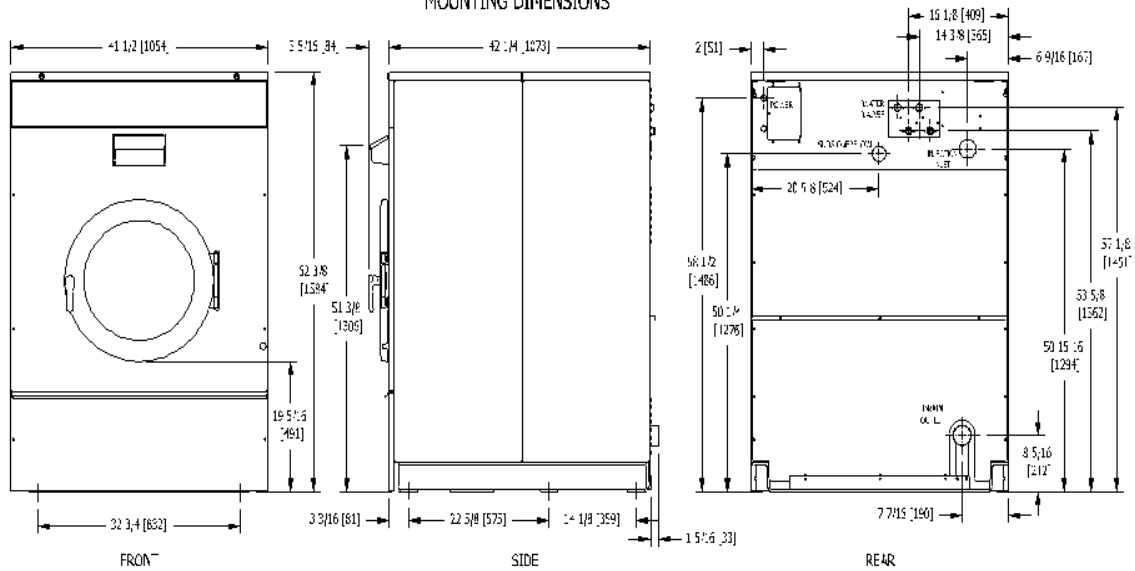

T-675 Mounting Dimensions

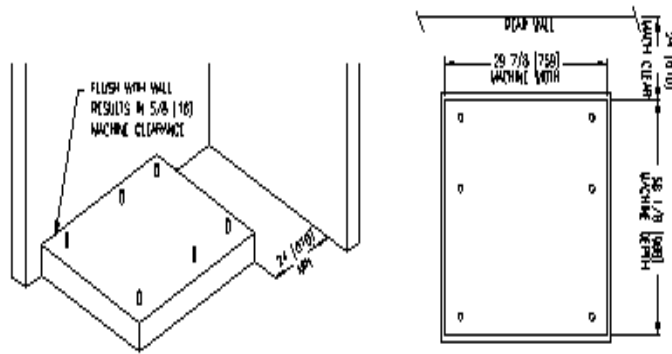

FLOOR OUTLINE
Figure 1-2

3/4" X 8" CO. B BOLTS
HEADED BY 4" SQ. FISH PLATE OR EQUIV.
(2 1/2" BOLT PROTRUSION)

19mm X 200mm CO. B BOLTS
HEADED BY 100mm SQ. FISH PLATE
OR EQUIV.
(64mm BOLT PROTRUSION)

OR
TITEL ADHESIVE ANCHORING SYSTEM
MULTI TAP SUPER RODS 3/4" X 10 AND ADHESIVE CAPSULES
FOR MORE INFORMATION CALL
MULTI CUSTOMER SERVICE
1-800-679-8000
OR
EQUIVALENT EPOXY OR ACRYLIC ADHESIVE ANCHOR

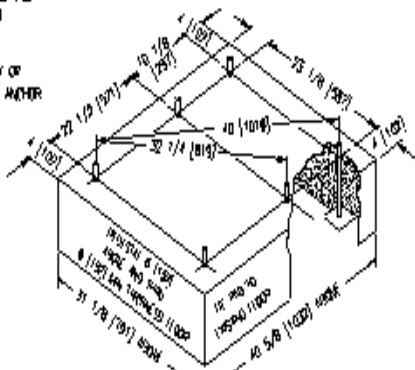

PEDESTAL SHOULD BE
4000 PSI (28 MPa) MIN CONCRETE
REINFORCED WITH
WESH OR RODS

NOTE: GROUTING BETWEEN
BASE AND CONCRETE IS
REQUIRED.

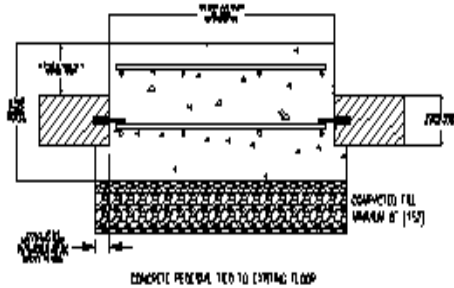

RAISED CONCRETE PEDESTAL MOUNTING OPTION
Figure 1-4

OR EQUIVALENT EPOXY OR ACRYLIC ADHESIVE ANCHOR
AND FLUSHED WITH MACHINE

MACHINE MOUNTING DETAIL
Figure 1-3

T-975 Mounting Dimensions

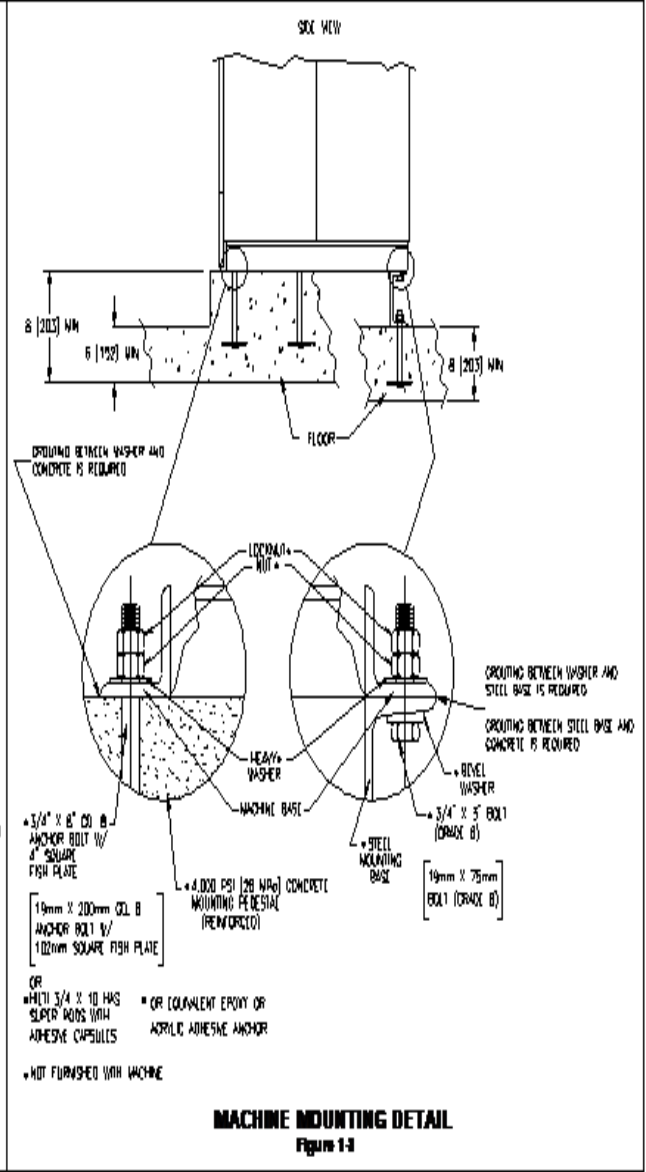
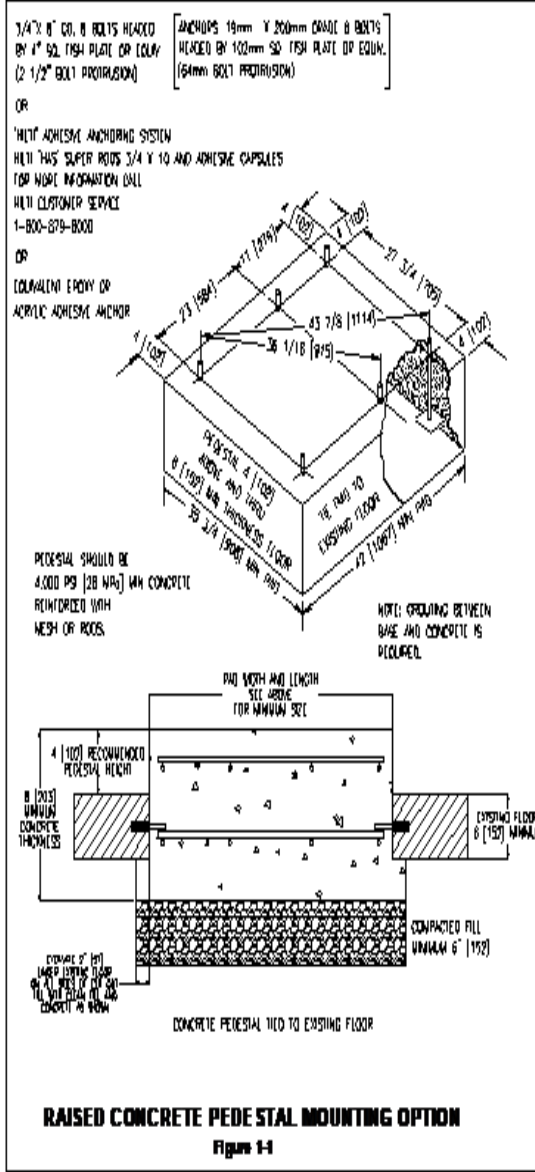
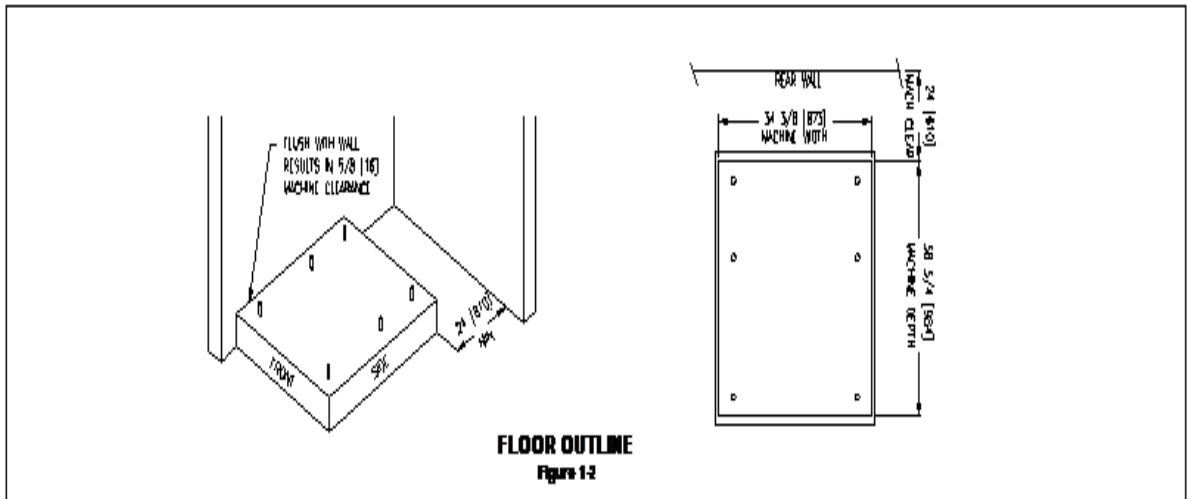

- 3/4" X 8" CO. B ANCHOR BOLT 1/4" SQUARE FISH PLATE
- 19mm X 200mm GCL B ANCHOR BOLT 3/4" 102mm SQUARE FISH PLATE
- 4,000 PSI (28 MPa) CONCRETE MOUNTING PEDESTAL (REINFORCED)
- OR EQUIVALENT EPOXY OR ADHESIVE CAPSULES
- NOT FURNISHED WITH MACHINE
- OR EQUIVALENT EPOXY OR ACRYLIC ADHESIVE ANCHOR

T-1475 Mounting Dimensions

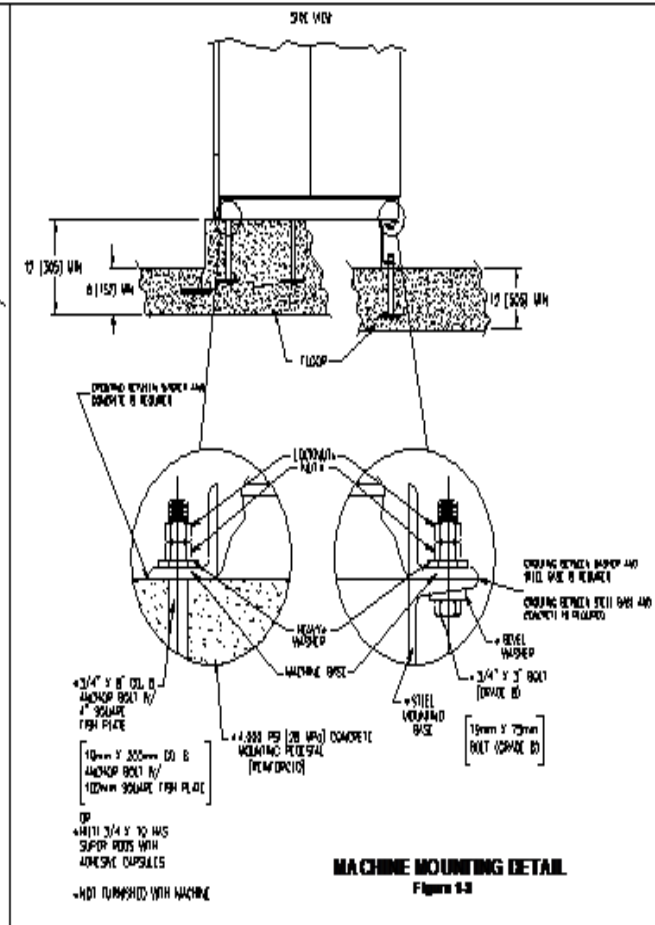
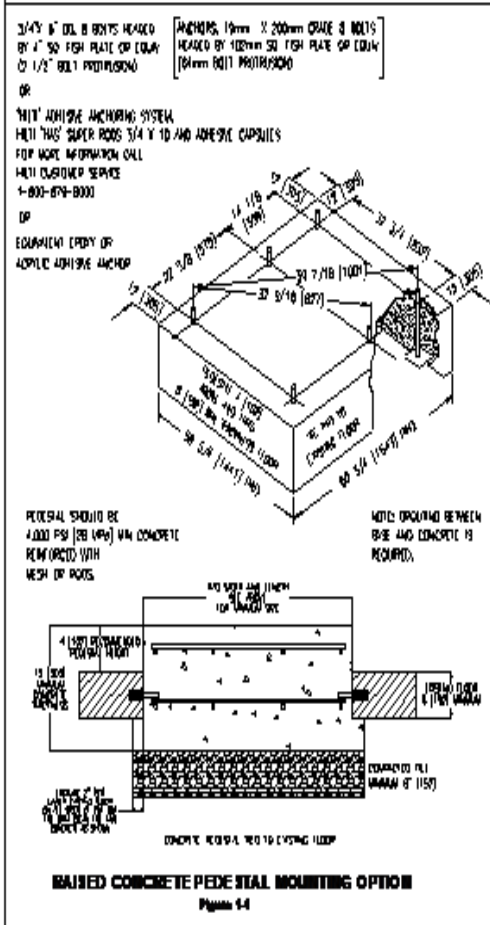
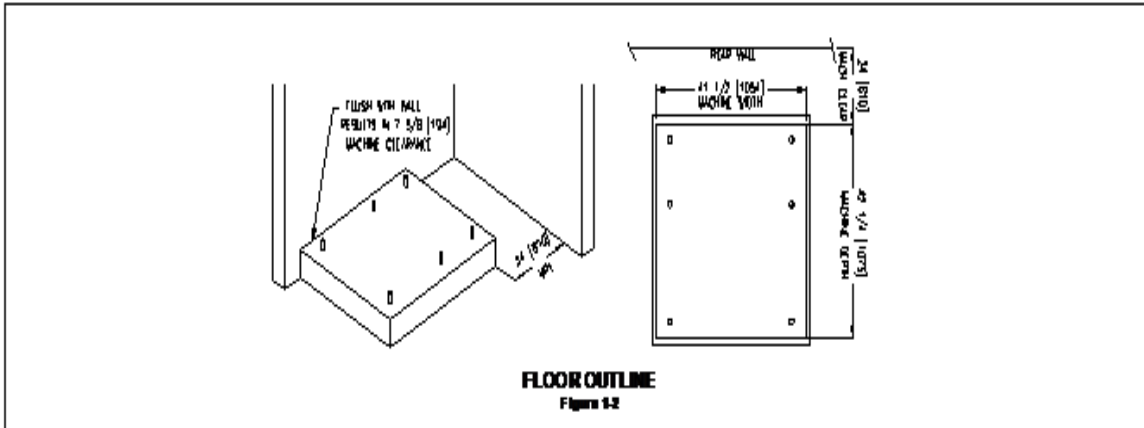

Notes

Lined area for taking notes, consisting of numerous horizontal lines.



Section 2:

Machine Installation & Operating Instructions

Installation & Operation

All washers must be installed in accordance with all local, state, and national building, electrical, and plumbing codes in effect in the area.

Foundation Requirements

This machine is designed for use on or over bare concrete floor - not to be used above combustible flooring, such as carpet or wood. The washer must be securely bolted and grouted to a substantial concrete floor, or mounted and grouted upon a suitable base that is securely bolted and grouted to a substantial concrete floor.

CARE MUST BE TAKEN WITH ALL FOUNDATION WORK TO ENSURE A STABLE UNIT INSTALLATION, ELIMINATING POSSIBILITIES OF EXCESSIVE VIBRATION.

All installations require concrete floors and quality grade anchor bolts or expansion anchors. Mounting hardware is not provided with the machines. Refer to appropriate model Machine Mounting Detail Figures 1-1, 1-2, and 1-3 for floor thickness and bolt sizes. See mounting diagram for overall washer dimensions.

2.2 MOUNTING HEIGHT

A concrete pedestal or steel-mounting base that elevates the machine above the floor level is suggested to provide easy access to the loading door.

Suggested Amount to Elevate Washer:

T-350: approximately 8 inches (203 mm)

T-450: approximately 6 inches (152 mm)

T-650/750/950/1450: approximately 4 inches (102 mm)

T-675/975/1475: approximately 4 inches (102 mm)

Contact a Dexter laundry equipment distributor for recommended steel mounting bases. Available steel mounting bases:

Washer Part Number	Height
T-350 9945-121-001	8" (203 mm)
T-450 9945-123-001	6" (152 mm)
T-650/675 9945-145-001	6" (152 mm)
T-750 9945-117-001	6" (152 mm)
T-950/975 9945-103-001	4" (103 mm)
T-950/975 9945-118-001	6" (152 mm)
T-1450/1475 9945-145-001	4" (103 mm)

If an elevated concrete pedestal is desired, it should be embedded and tied into the existing floor. **DO NOT** install a pad on top of the existing floor. Cut through existing floor as shown below. See Machine Mounting Detail Figures for floor thickness and bolt sizes.

EXPANSION ANCHORS ARE NOT RECOMMENDED FOR USE IN CONCRETE PEDESTALS BECAUSE THE ANCHORS ARE TOO CLOSE TO AN EDGE, CAUSING IT TO BREAK OUT.

2.3 FOUNDATION AND PAD OPTIONS

All installations require reinforced concrete floors. Refer to appropriate model Machine Mounting Detail Figures 1-1, 1-2 and 1-3 for minimum floor thickness and minimum pad sizes. See mounting diagram for overall washer dimensions.

Refer to appropriate model Figure 1-4 for side by side mounting dimensions.

2.3.1 WASHER INSTALLATION ON EXISTING FLOOR:

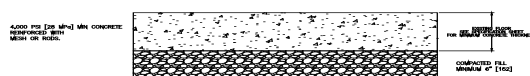

2.3.2 WASHER INSTALLATION ON NEW FLOOR:

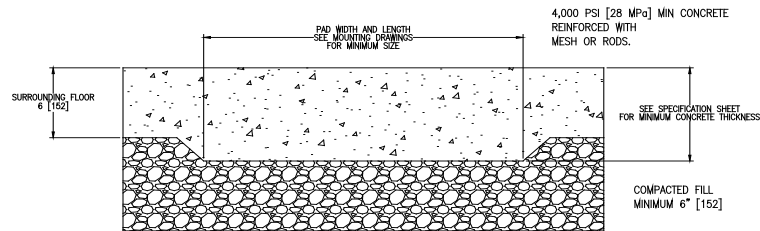

If the existing floor is not reinforced concrete that meets the minimum thickness requirements, DO NOT install a pad on top of the existing floor. The existing floor and the machine pad must be tied together as one piece as follows:

- 1) Cut an opening through the existing floor that is wider and deeper than the washer as shown below. See Machine Mounting Details for dimensions.
 - 2) Excavate to a depth that allows for 6" [152] minimum of compacted fill plus the minimum required concrete thickness. Also excavate 2" [51] under the existing floor so that the new concrete is poured under the floor as well.
 - 3) Back fill with clean fill dirt and compact dirt, making sure to allow for the minimum thickness concrete pad to be poured.
 - 4) Drill holes around the perimeter of the existing floor to install reinforcing bars to tie the new pad to the existing floor. Drill 2-1/2" [64] deep into the existing floor on 12" [305] centers around the entire perimeter.
 - 5) Clean holes and fill half-way with acrylic adhesive rated for commercial-grade machine installations.
 - 6) Use #4 (60 ksi) reinforcing bar to tie the new pad to the existing floor. Tie the bars together at intersections and use supports to hold bars in the proper depth in the pad.
 - 7) After adhesive has cured, pour 4000 psi concrete up to level with the existing floor plus any extra elevated pedestal desired 4-10" [102-254].
- Concrete must be done in one pour so that the entire pad cures as one piece.

2.3.3.1 NEW PAD TIED TO EXISTING FLOOR (LEVEL WITH FLOOR):

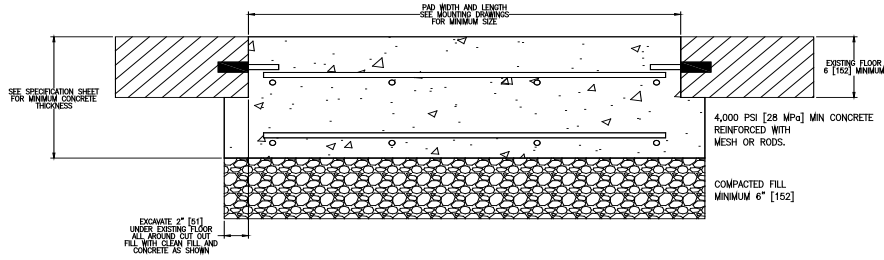

2.3.3.2 NEW RAISED CONCRETE PEDESTAL TIED TO EXISTING FLOOR

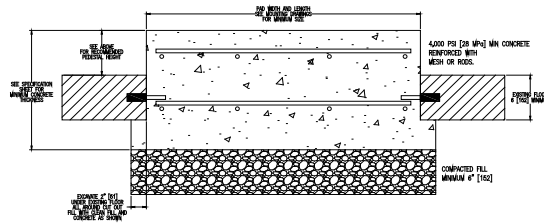

2.3.4 STEEL MOUNTING BASE ON CONCRETE FLOOR

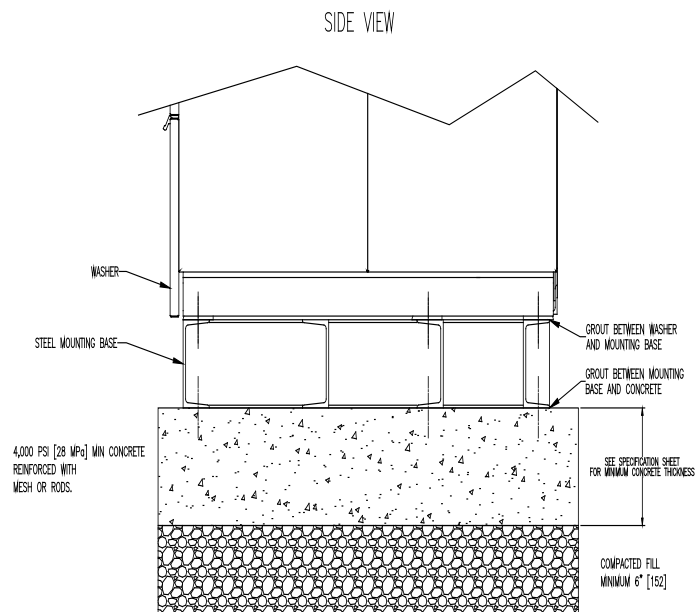

2.4 MACHINE ANCHORING

All installations require concrete floors and quality grade anchor bolts or expansion anchors. Mounting hardware is not provided with the machines. Refer to appropriate model Machine Mounting Detail Figures 1-1, 1-2 and 1-3 for floor thickness and bolt sizes. See mounting diagram for overall washer dimensions. EXPANSION ANCHORS ARE NOT RECOMMENDED FOR USE IN RAISED CONCRETE PEDESTALS BECAUSE THE ANCHORS ARE TOO CLOSE TO AN EDGE, CAUSING IT TO BREAK OUT.

ANCHORING OPTIONS:

2.4.1 Cast in place bolts headed by square fish plates. See Machine Mounting Detail Figures 1-1 thru 1-3 for exact washer model.

Or after concrete has completely cured:

2.4.2 Use Hilti Adhesive System 'HAS' Rods and adhesive capsules. See Machine Mounting Detail Figures 1-1 thru 1-3 for exact washer model.

2.4.3 Or use an equivalently rated epoxy or acrylic adhesive anchor.

As an installation aid, the anchor pattern can be found on the back panel of the washers and can be used as a template. Compare panel to the mounting dimension drawing to find the right holes. Example:

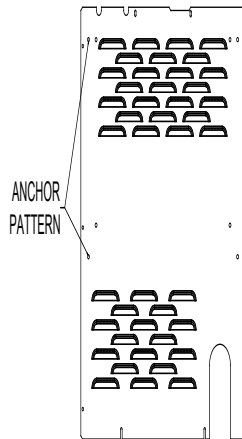

2.5 MACHINE GROUTING

After concrete has cured completely and anchors have cured completely into place:

2.5.1 Position washer over the mounting anchors.

2.5.2 Raise the washer 1/2" [12.7] off the mounting surface and place spacers under the corners of the washer base.

2.5.3 Level the washer, leaving washer at least 1/2" [12.7] off the mounting surface.

Do not permanently support the washer with spacers under the corners. Machine must be grouted, and spacers must be removed.

2.5.4 Mix non-shrinking machinery grout according to the grout instructions. The grout should not be too runny or too firm. Completely fill the 1/2" [12.7] space between the washer base and the mounting surface. Force grout under all base angles and plates until completely filled. Fill around all anchor bolts.

2.5.5 Finger tighten all nuts to anchor bolts.

2.5.6 When the grout has started to stiffen (but before it is cured), remove the spacers from the corners and allow the washer to settle into the wet grout. Fill in any voids as necessary with additional grout.

2.5.7 Allow grout to completely cure, then tighten all nuts to securely fasten the washer to the grouted mounting surface.

2.5.8 Retighten nuts after 5 days of operation and check quarterly.

If using a steel mounting base, first grout the steel mounting base to the concrete floor using the above steps, then repeat the steps for mounting and grouting the washer to the steel mounting base.

DEXTER DYNAMIC LOADING CHART										
Model	Dry Weight Capacity (lb [kg])	Extract Speed (RPM)	Extract G-Force	Maximum Static Load (lb [kN])	Static Load Pressure (lb/sq ft [kN/ sq m])	Total Dynamic Load (lb [kN])	Dynamic Load Pressure (lb/sq ft [kN/ sq m])	Dynamic Load Frequency (Hz)	Maximum Vertical Load (lb [kN])	Maximum Moment About Washer Base (ft*lbs [m-kN])
Express Washers										
T-350	20 [9.1]	819	200	447 [2.0]	94 [4.5]	800 [3.6]	168 [8.0]	13.7	1203 [5.4]	1571 [2.1]
T-450	30 [13.6]	750	200	618 [2.7]	113 [5.4]	1200 [5.3]	220 [10.5]	12.5	1756 [7.8]	2631 [3.6]
T-650	40 [18.1]	750	200	882 [3.9]	134 [6.4]	1600 [7.1]	243 [11.6]	12.5	2384 [10.6]	3508 [4.8]
T-750	50 [22.7]	685	200	1119 [5.0]	166 [7.9]	2000 [8.9]	297 [14.2]	11.4	2970 [13.2]	4667 [6.3]
T-950	60 [27.2]	685	200	1206 [5.4]	150 [7.2]	2400 [10.7]	299 [14.3]	11.4	3460 [15.4]	5600 [7.6]
T-1450	90 [40.8]	617	200	1635 [7.3]	163 [7.8]	3600 [16.0]	360 [17.2]	10.3	5012 [22.3]	9413 [12.8]
Express Plus Washers										
T-675	40 [18.1]	993	350	882 [3.9]	134 [6.4]	1600 [7.1]	243 [11.6]	16.6	2384 [10.6]	3508 [4.8]
T-975	60 [27.2]	969	400	1206 [5.4]	150 [7.2]	2400 [10.7]	299 [14.3]	16.2	3460 [15.4]	5600 [7.6]
T-1475	90 [40.8]	816	350	1635 [7.3]	163 [7.8]	3600 [16.0]	360 [17.2]	13.6	5012 [22.3]	9413 [12.8]

Note: The out-of-balance loading conditions may vary dependent on load size and material.

Plumbing

Water supply hoses are provided with each machine. The threaded connections on the hoses are $\frac{3}{4}$ -11 $\frac{1}{2}$ NHT for 60 Hz models and $\frac{3}{4}$ -14 BSP for 50 Hz models. Separate hot and cold water lines must be supplied to the machine, maintaining 30 psi to 120 psi (207 kPa to 827 kPa) water flow pressure. A 140°F (60°C) hot water supply is recommended for best washing results. Do not exceed 180°F (82°C) water temperature.

Drain

The drain outlet tube size: T-650, T-750, T-950, and T-1450 is 3 inches (76 mm) in diameter. Any drain hose used must be lower than the drain valve to assure proper draining.

Protective Film

The machine may have protective adhesive film on the front escutcheon area and the front and side stainless steel panels. The film may be peeled off before putting the machine into service.

Electrical

The Dexter single/three-phase 208-240VAC 60 Hz (single phase 230VAC 50 Hz) non-heated washing machines and three phase only 208-240VAC 60 Hz (400VAC 50 Hz) heated washing machines are intended to be permanently installed appliances. No power cord is provided. The machine should be connected to an individual branch circuit not shared by lighting or other equipment. A means for disconnection with a contact separation of at least 1/8" (3 mm) must be provided. The connection should be sheathed in liquid-tight or approved flexible conduit, or equivalent, with conductors of the proper size and insulation (50 Hz: The sheath of the supply cord must be at least equivalent to that of a cord complying with IEC 227 or IEC 245). A qualified technician should make such connections in accordance with the wiring diagram. See specification sheet for minimum recommended wire size. Individual circuit breakers for each unit are required. Do not use ground-fault (earth-fault) circuit breakers or ground-fault (earth-fault) circuit interrupter outlets.

To Make Electrical Connections

Disconnect all power to the washer. Remove the top panel of the washer and locate the power terminal block near the back of the control compartment.

If power is 208-240V-3PH-60Hz, connect L1, L2, L3, and Ground. If there is a high leg, it must NOT be connected to L1 or L2. However, failure due to a voltage surge on the high leg is not covered by equipment warranty. Contact Dexter Laundry with any questions.

If power is 208-240V-1PH-60Hz, connect L1, L2, and Ground (Only Non-Heated Washers may be connected to 1PH power).

If power is 400V-3PH-50Hz, connect L1, L2, L3, N, and Earth. If there is a high leg, it must NOT be connected to L1 or L2. However, failure due to a voltage surge on the high leg is not covered by equipment warranty. Contact Dexter Laundry with any questions. (Only Heated Washers may be connected to 400V-3PH power).

If power is 230V-1PH-50Hz, connect L1, N, and Earth (Only Non-Heated Washers may be connected to 1PH power).

NOTE: It is important that the grounding screw next to the power terminal block be connected to a good external ground.

Dexter Recommended Connections	Controller / Injector Signals
Detergent	1
Bleach	2
Starch	3
Sour/Softener	4
	5
	6
	7
	8
	9
	10

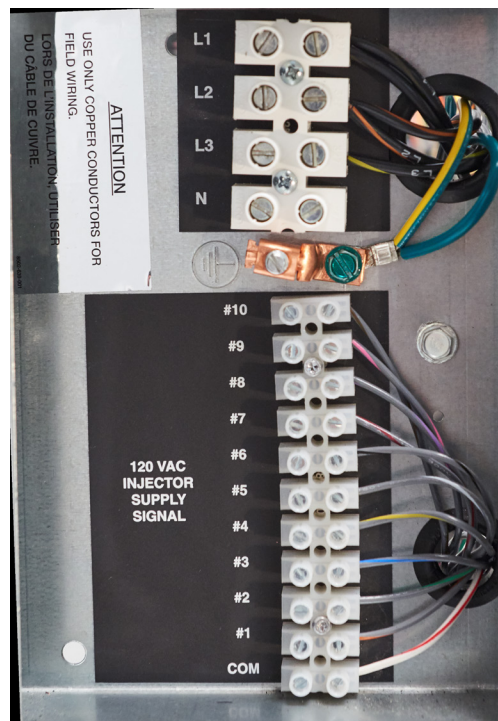

WARNING

Always disconnect electrical power to the machine before performing any adjustments or service.

60 HZ CONTROL TRANSFORMER CONNECTIONS

NOTE: transformer must be set at proper tap for proper operation.

The controls transformer is located inside the control trough and steps a range of 208 to 240 volts down to 115VAC and 24VAC. There are two terminals on the controls transformer for the primary (incoming) power. Use the terminal marked "208V" for power supplies between 208 and 219 volts. Use the terminal marked "240V" for power supplies between 220 and 240 volts. Refer to the following for control transformer connections.

CONTROL TRANSFORMER CONNECTIONS

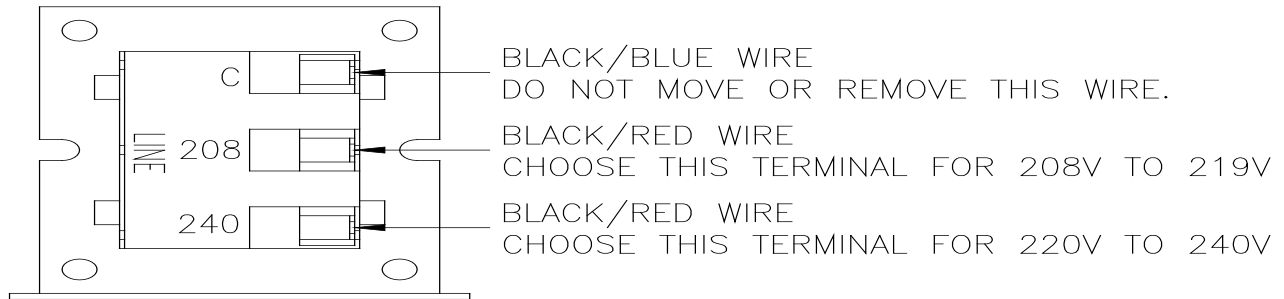

CONTROLS TRANSFORMER (230V 50 Hz models only)

The controls transformer is located inside the control trough and steps a range of 180 to 255 volts down to 24 volts. There are two terminals on the controls transformer for the primary (incoming) power. Use the terminal marked "L1 200V" for power supplies between 180 and 229 volts. Use the terminal marked "L1 230V" for power supplies between 230 and 255 volts.

CONTROL TRANSFORMER CONNECTIONS

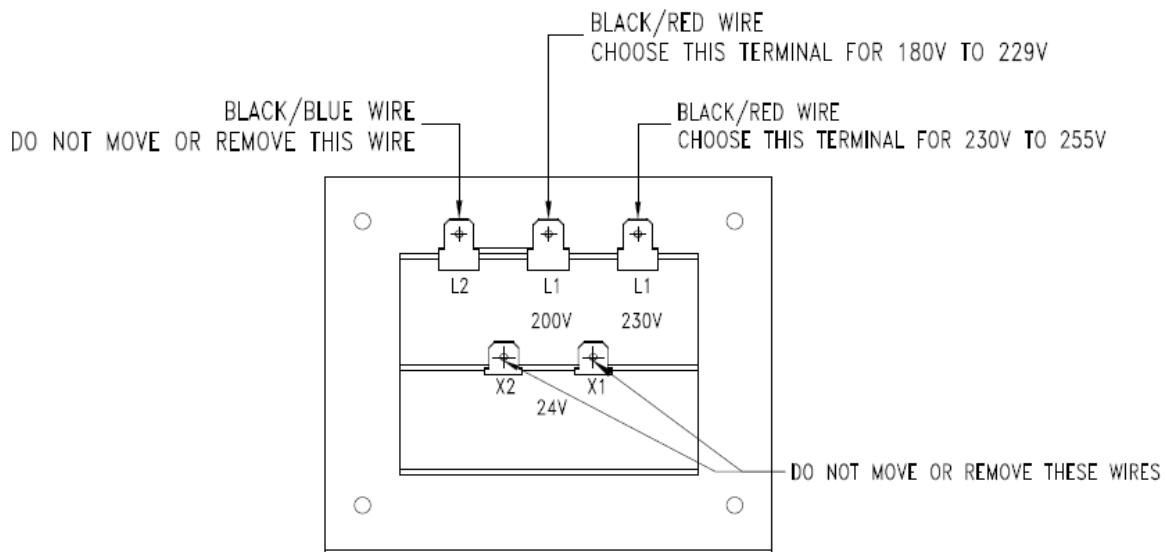

50 Hz Control Transformer Connections

INJECTION SOURCE CONNECTIONS

The washer control may be programmed to send ten 120VAC output signals for 60Hz models (or 24VAC for 50Hz) for a chemical injection system. The signals are not intended as a power source and must be limited to less than 100 milliamps of current. There is a separate terminal block for connection of the external injection signals. For the injection sources, program codes 1 through 10 and their respective terminal block connections are as shown in Table 1.

Dexter Recommended Connections	Controller / Injector Signals
Detergent	1
Bleach	2
Starch	3
Sour/Softener	4
	5
	6
	7
	8
	9
	10

Table 1: Injection Signal and Circuit Identification

If required, chemical injection hoses are to be inserted into the injection inlet at the upper right rear of the washer. These hoses should be inserted into the round PVC pipe a distance of:
T-650, 750, 950 and 1450 a minimum of 14" (36 cm) and a maximum of 18" (46 cm)
This will eliminate chemical buildup in the pipe and/or restrict water flow to the tub. Secure the hoses as required.

Fusing Requirements:

Dual element time delay fuse or equivalent breaker of amperage specified below.

- 1 Phase or 3 Phase 15 amp, 208-240VAC
- WN0650-12, WN0750-12, WN0950-12, and WN1450-12
- 1 Phase 15 amp, 230VAC
- WN0650-39, WN0750-39, WN0950-39, and WN1450-39

OPERATION CHECK

During intermediate spin and final spin, the cylinder should turn in a counterclockwise direction when viewed from the front of the machine. If spin is clockwise, the T1 and T2 motor wires connecting to terminal T1 and T2 on the variable frequency drive should be swapped. Remove power to the machine before opening service panels and swapping wires.

OPERATING INSTRUCTIONS

STARTING THE WASHER

1) Turn on power to the washer.

A) Load the laundry.

Place laundry into the cylinder and latch the door securely. Be sure laundry does not get caught between the door gasket and tub front when closing the door. Maximum load is the dry weight capacity listed in the specification sheet. Do not exceed the listed capacity weight.

NOTE: To begin closing the door, the handle must be in the horizontal position. After moving the door to the closed position, the handle must be turned down to the vertical position in order to latch the door for machine operation.

2) Select wash cycle.

Select the appropriate cycle for the type of load being washed. Use the “UP” and “DOWN” keys to change the cycle on the display to the desired cycle and press the enter button to select.

3) Add washing chemicals.

If not using a chemical injection system, add low sudsing powdered detergent into the “DETERGENT” compartment of the automatic dispenser on the top or front of the washer. If liquid wash products are used in the “DETERGENT” compartment, they must be added at the beginning of the wash cycle. If desired, add fabric softener to the “FABRIC SOFTENER” compartment. Use the amount of fabric softener as recommended by the manufacturer. If the machine is set for pre-wash, washing products can be added to the round opening of the dispenser or put in with the clothes when loading the washing machine. If bleach is desired, DO NOT place into dispenser until the ADD BLEACH message is displayed.

4) Start wash cycle.

Press enter to start the cycle. The display will show cycle information throughout the cycle. The door will lock and remain locked until the end of the cycle. Press the red pause button to pause the cycle. Select Start to restart the cycle or select Cancel Cycle to end the wash cycle.

END OF CYCLE

A tone will sound (if programmed) and the display will indicate that the cycle has ended. The door can now be opened. Immediately remove contents of washer. Leave the door open when the machine is not in use.

EMERGENCY STOP / SAFETY DOOR LOCK

This machine is equipped with a safety door lock that locks the door when the cycle is started until the cycle is complete. The door lock prevents opening the door for up to 3 minutes if the power is interrupted during the cycle. The Emergency Stop button ends the cycle and allows the door to be opened after the Safety Door Lock releases. When the Emergency Stop button is pressed an alarm will sound (if programmed), an "Emergency Stop" message will be displayed, tumbler movement will begin to slow and water will begin draining from inside the washer. Though the machine may end movement quickly, it may take up to 3 minutes for the door to unlock. During that time the alarm will continue to sound. When the alarm stops, the door may be opened. Inspect the washer as needed and reset the emergency stop button by turning it clockwise. Reset the washer by selecting Cancel. The washer may be restarted by closing and latching the door, and starting a new cycle.

3.4 VARIABLE FREQUENCY DRIVE INDICATORS

There are three small colored LEDs located on the upper region of the Variable Frequency Drive (VFD). They are labeled as "READY", "RUN", and "FAULT" and can be used for troubleshooting. The definitions of the LEDs are listed in the table below.



LED Status	Washer Condition
Steady Yellow	Tumbling
Blinking Yellow	Stop from Tumble
Steady Yellow	Ramp to Intermediate or Final Extract Spin
Steady Yellow	Spinning (Intermediate or Final)
Blinking Yellow	Stop from Spin (Intermediate or Final)
Steady Green	Idle Mode (No Cylinder Movement)
Steady Red	VFD fault
Blinking Red	VFD warning

Variable Frequency Drive Indicators

Injection Source Details

The washer control may be programmed to send output signals for a chemical injection system. There is a separate terminal block for connection of the external injection signals. For the injection sources, program codes 0 through 6 are as shown in the table below. Injection signal will trigger a 120 volt reading at rear terminal block for approximately 5-10 seconds and will start to trigger at about 10-15 seconds after start of fill bath. (Chemical Injection Signals are shown in the programming section.)

Detergent Measurements By Washer Model



Triple Load T-350 Washer



Mega Load T-450 Washer

TRANSIENT VOLTAGE SURGE SUPPRESSORS

Like most electrical equipment your new machine can be damaged or have its life shortened by voltage surges due to lightning strikes which are not covered by factory warranty.

Local power distribution problems also can be detrimental to the life of electrical components. We recommend the installation of transient voltage surge suppressors for your new equipment. These devices may be placed at the power supply panel for the complete installation and don't require an individual device for each machine.

These surge protectors help to protect equipment from large spikes and also from small ongoing spikes in the power that occur on a day to day basis. These smaller surges can shorten overall life of electrical components of all types and cause their failure at a later date. Although they can't protect against all events, these protective devices have a good reputation for significantly lengthening the useful life of electronic components.

Electronic Components are helped to have a longer useful life when they are supplied with the clean stable electrical power they like.

Notes

Lined area for notes.



Section 3:

Machine Programming Instructions

O-SERIES WASHERS

PROGRAMMING WITH DEXTERLIVE



Our O-Series washers are simple and easy to program with DexterLive.com. This guide will provide an overview of some of the features DexterLive offers and how to create the cycles that fit your location's specific needs.

Set-Up an Account and Location

If you don't already have a DexterLive account, it is easy to register at DexterLive.com.

Once you have an account, you can create a new location and customize that location based on a specific application. Simply select on-premise laundry as your location type and the application type option will be available.

Tip: If you have multiple applications, you can provide a generic name (e.g., Motel) and use the same custom programs across multiple locations.

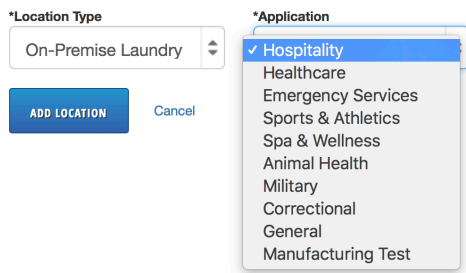

Add Equipment

Before programming cycles, you need to add equipment. Because functionality differs between model types, it is important to select the right model. You can name your machine, input the serial number, and add the DexterLive ID if you choose. However, this information is not required.

Tip: To create a generic program to be used in many locations, leave the serial number and DexterLive ID blank.

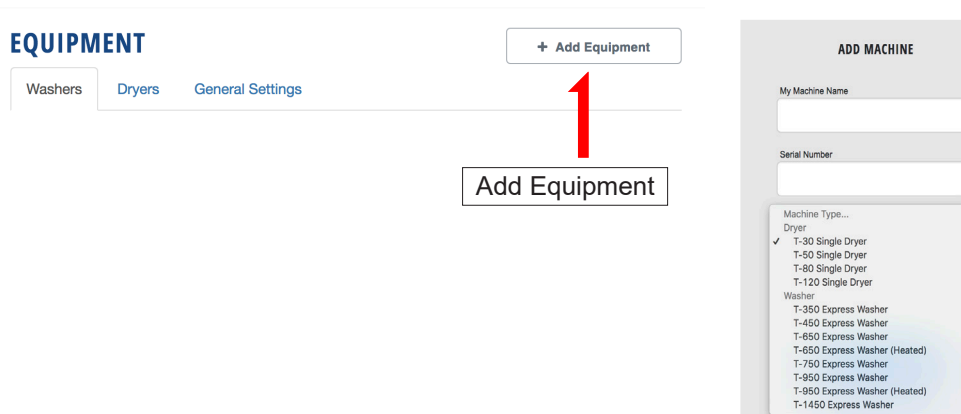

General Settings

General settings will set the global parameters for your location. These parameters will impact all washers and dryers added to that location.

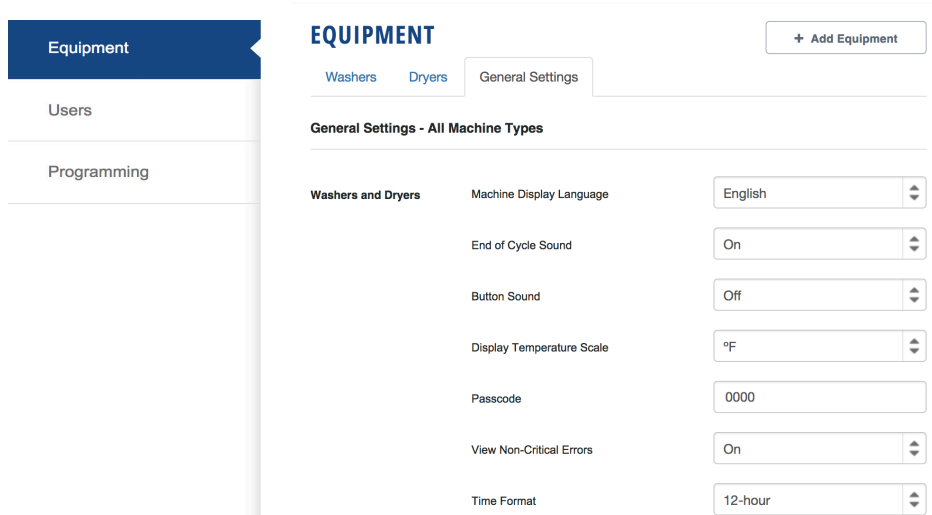

Setting	Options	Notes
Machine Display Language	Multiple	Changes the language of cycles, stages, and prompts that are displayed on the control. Individual cycles can still be set for different languages.
End of Cycle Sound	On / Off	Buzzer will sound when cycle is complete.
Button Sound	On / Off	Audible feedback when buttons are pressed.
Display Temperature	°F / °C	Choose between Fahrenheit or Celsius.
Passcode	0000 – 9999	Select a code for management screen access
View Non-Critical Errors	On / Off	Will display errors such as Slow Fill / Slow Drain during cycle. If OFF, these errors will still register in the cycle log, but will not be shown on the display.
Time Format	12 hr / 24 hr	Changes how time is displayed on the control.

Machine Settings

Most programming functions are available under the individual machine settings. Under this selection, you can review, edit, create, or delete cycles as well as select injection types and customize tumble speeds.

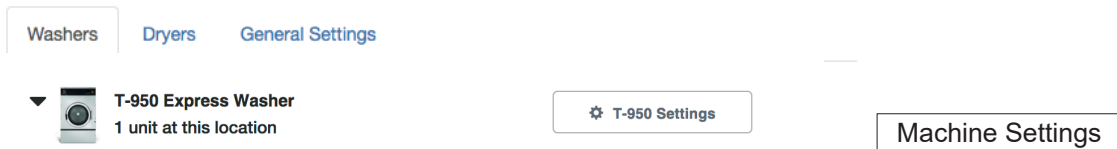

Cycles

The cycle page allows you to add, edit, copy, delete, or reorder cycles.

Cycles
Optional Settings

	CYCLE NAME	TOTAL TIME	MAX FILL TEMP	MAX TUMBLE MODE			
Cycle 1	White Sheets	27 min	Hot	Normal	☰	📄	🗑️
Cycle 2	Color Sheets	22 min	Warm	Normal	☰	📄	🗑️
Cycle 3	White Towels	28 min	Hot	Normal	☰	📄	🗑️
Cycle 4	Color Towels	23 min	Warm	Normal	☰	📄	🗑️
Cycle 5	Blankets	23 min	Warm	Normal	☰	📄	🗑️
Cycle 6	Delicates	23 min	Warm	Delicate	☰	📄	🗑️
Cycle 7	Rags & Mops	35 min	Hot	Normal	☰	📄	🗑️
Cycle 8	Uniforms	29 min	Hot	Normal	☰	📄	🗑️
Cycle 9	Stain Treatment	60 min	Hot	Normal	☰	📄	🗑️
Cycle 10	White Linens	33 min	Hot	Normal	☰	📄	🗑️
Cycle 11	Colored Linens	32 min	Hot	Normal	☰	📄	🗑️
Cycle 12	White Uniforms	36 min	Hot	Normal	☰	📄	🗑️

+ Add Cycles

Legend		
	Edit Cycle	Select anywhere on the cycle description (cycle name, target temp, material, or target) to open the cycle details for editing.
☰	Reorder Cycle	Select and hold to move a cycle up or down in the listing. This will change the order it is displayed on the control.
📄	Copy Cycle	This will duplicate the cycle. Tip: It is easiest to edit an existing cycle instead of creating a new cycle. Copy the cycle that is closest to the cycle you want to create and edit that cycle. If a default cycle doesn't meet your needs, select "Add Cycle" and choose a default cycle from another application. You can always change the cycle name in the edit section.
🗑️	Delete Cycle	This will delete an existing cycle.
+ Add Cycles	Add Cycle	This will allow you to add a preset cycle from another industry or another location.

Cycle Settings

A cycle can be edited by clicking on the cycle name in the Cycles page. The name and language can be customized for that specific cycle. Changing the language for a cycle will change the status, stage names, and prompts displayed during that particular cycle.

Cycle 1 - White Sheets Settings

Cycle Name

White Sheets

Language ⓘ

English

Tip: If a location has multi-lingual employees, the same cycle can be duplicated and programmed for different languages. For example, in a location with English and Spanish speaking employees, program White Sheets to the desired settings. Copy that cycle, set that cycle language to Spanish, and note the name change to Sabanas Blancas. This will allow all employees to read the necessary prompts and descriptions on the control.

Stages

A stage can also be considered a bath, such as prewash, wash, rinse, etc. Each cycle can consist of 20 unique stages. Within each stage, the following parameters can be selected.

Setting	Options	Options	Description
Fill	Bath Temperature	Hot Warm Cold No Fill	
	Auxiliary Temperature (Heated Models Only)	No Heat 100F (38C) – 195F (91C)	Heated models only. Temperature is programmable in 5 °F / 3° C increments.
	Water Level	Low High	These settings can be controlled by the electronic pressure sensor.
Soap / Chemicals	Injection Type 1 – 3	None Detergent Flush Softener Flush Chemical 1-10	Three unique soap options are available for each stage. See optional settings for setting chemical injection details.
	Injection Delay	0 – 150 seconds	If Delay Fill is ON this is the time from when the low water level is met. If Delay Fill is OFF this represents the time from start of the stage to when chemical injection begins.
	Injection Duration	1 – 240 seconds	The amount of time chemicals will be injected.

Bath	Soak Time	0 – 60 minutes	Time from when fill is complete to when agitation begins.
	Agitation Time	0 – 30 minutes	Time load will tumble.
	Agitation Type	Normal Delicate Custom 1-3	Aggressiveness of the tumble action. Tip: For wet clean or super-delicate applications, create your own custom agitation type in the optional settings.
Drain	Drain Method	Standard None	Tip: Select None for a soak longer than 60 minutes
Spin	Spin Time	0-30 minutes	Amount of time in spin mode.
	Spin Speed	60 – 200G	Spin time must be selected to set spin speed. Speed is programmable in 20G increments.

Continue adding or editing stages as appropriate to create the specific cycle you want. Remember, you have the ability to customize all 20 stages, so get creative and gain Total Control over your laundry experience.

Tip: See example below illustrating how stages can be customized to create a specialty cycle, such as an extended soak.

Example - Extended Soak:

Parameter	Stage 1: Prewash	Stage 2: Soak	Stage 3: Soak	Stage 4: Soak / Wash	Stage 5: Rinse	Stage 6: Final Rinse
Temperature	Cold	Cold	NA	NA	Cold	Cold
Water Level	High	High	High	High	High	High
Soap	None	Chemical 1, 2 & 3	None	None	Chemical 4	Chemical 5
Soak Time	0 mins	60 mins	60 mins	15 mins	0 mins	0 mins
Agitate Time	5 mins	0 mins	0 mins	30 mins	15 mins	15 mins
Agitation Type	Normal	NA	NA	Normal	Normal	Normal
Drain Method	Standard	None	None	Standard	Standard	Standard
Spin Time	NA	NA	NA	2 mins	5 mins	5 mins
Spin Speed	NA	NA	NA	200G	100 G	200G

Optional Settings

These settings will only apply to that specific model type. For instance, optional settings for the T-950 will not apply to a T-650. These will need to be set individually by model.



T-950 EXPRESS WASHER

Cycles

Optional Settings

Custom Agitation

DexterLive has the ability to create 3 custom agitation types. These custom agitations will enable you to create cycles such as a wet clean cycle with “rocking” methods versus a true tumble agitation.

Cycles

Optional Settings

Settings for All Cycles on the T-950 Express Washer. These settings will be applied to only this model type.

Agitation

		Tumble Speed	Tumble Time	Dwell Time
Custom 1	Custom 1	Normal	15 seconds	0 seconds
Custom 2	Custom 2	Normal	15 seconds	0 seconds
Custom 3	Custom 3	Normal	15 seconds	0 seconds

Settings	Options			Notes
Tumble Speed		Normal (G / RPM)	Delicate (G / RPM)	
	T-350	0.9 / 55	0.6 / 47	
	T-450	0.9 / 50	0.6 / 41	
	T-650	0.9 / 50	0.6 / 41	
	T-750	0.9 / 43	0.6 / 36	
	T-950	0.9 / 43	0.6 / 33	
	T-1450	0.9 / 39	0.6 / 32	
Tumble Time	1 – 60 seconds			Controls how long the tumbler agitates before dwell. Tip: By selecting a short tumble time, you can prevent the tumbler from making a full rotation, creating a “sloshing” action versus a tumble action.
Dwell Time	0 – 60 seconds			Controls the length of pause between tumbler action. Tip: By selecting a long dwell time, you allow items to “settle” before restarting the tumbler action.

Tip: See example below for how a custom agitation can be used to create a wet clean cycle.

Example: Wet Clean

Agitation

Custom 1 Wet Clean Delicate 6 seconds 10 seconds

Tumble Speed Tumble Time Dwell Time

Parameter	Stage 1: Prewash	Stage 2: Soak	Stage 3: Soak	Stage 4: Soak / Wash	Stage 5: Rinse	Stage 6: Final Rinse
Temperature	Cold	Cold	NA	NA	Cold	Cold
Water Level	Low	High	High	High	High	High
Soap	None	Chemical 1	None	None	Chemical 5	Chemical 6
Soak Time	0 mins	10 mins	10 mins	10 mins	5 mins	5 mins
Agitate Time	2 mins	2 mins	2 mins	2 mins	2 mins	2 mins
Agitation Type	Wet Clean	Wet Clean	Wet Clean	Wet Clean	Wet Clean	Wet Clean
Drain Method	Standard	None	None	Standard	Standard	Standard
Spin Time	0 mins	NA	NA	0 mins	2 mins	2 mins
Spin Speed	NA	NA	NA	NA	60 G	100 G

Injection Source Names

Name specific injection sources to clearly show which chemical is being used in which stage or cycle.

Delay Fill

With Delay Fill on, the stage does not begin decrementing time until the water level is met. This ensures the load soaks or agitates the target time, even in cases of low water pressure and slow fills. The default settings have Delay Fill turned ON.

Delay Spin

Delay Spin can be set to OFF or up to 150 seconds. Delay Spin can be used in slow drain situations to reduce nuisance Slow Drain error codes. The default settings have Delay Spin turned OFF.

Programming

Once all cycles are set, the programming file (called userconfig.xml) can be downloaded following the instructions on the programming tab DexterLive.com.

PROGRAM YOUR MACHINES

1 Configure Settings with DexterLive.com
A. Add or select a location.
B. Add machines or edit machine settings in Equipment.
Note: All settings will be saved in your DexterLive account for future modifications.

2 Download Programming File
A. Click to download programming file.
B. Rename (based on your internet browser) the file to "userConfig.xml".
Note: Machine programming will not occur using a different file name than "userConfig.xml".

DOWNLOAD PROGRAMMING FILE

At the machine, you can enter management view by pressing up on the idle screen.

Management View	Minutes
1 - White Towels	34
2 - Color Towels	23
3 - White Sheets	32

Simply insert the USB, scroll to Import User Data, and begin using your customized washer cycles.

Programming Mode

- Edit Cycles
- Cycle Log
- Error Code Log
- Download Cycle & Error Log
- Import User Data**

2.11.5 MAXIMUM SPIN SPEED ADJUSTMENT (All washers except T-950)

If desired, the washer can be adjusted to limit the maximum extract spin speed for all wash cycles.

To make this adjustment, a jumper wire must either be installed or removed on the Variable Frequency Drive (VFD), depending on the washer model and desired speed. This Dexter jumper part number 8220-057-036 (qty 1) is factory supplied on terminal points "10V" and "RC". Remove this jumper to make new jumper connections if necessary. Refer to figure below for the approximate location of the control terminations on the Variable Frequency Drive (VFD) and for appropriate jumper connection points indicated with an "X" for the desired maximum spin speed setting. If no adjustment to the default spin speed is desired, do not remove or add any wires on VFD.

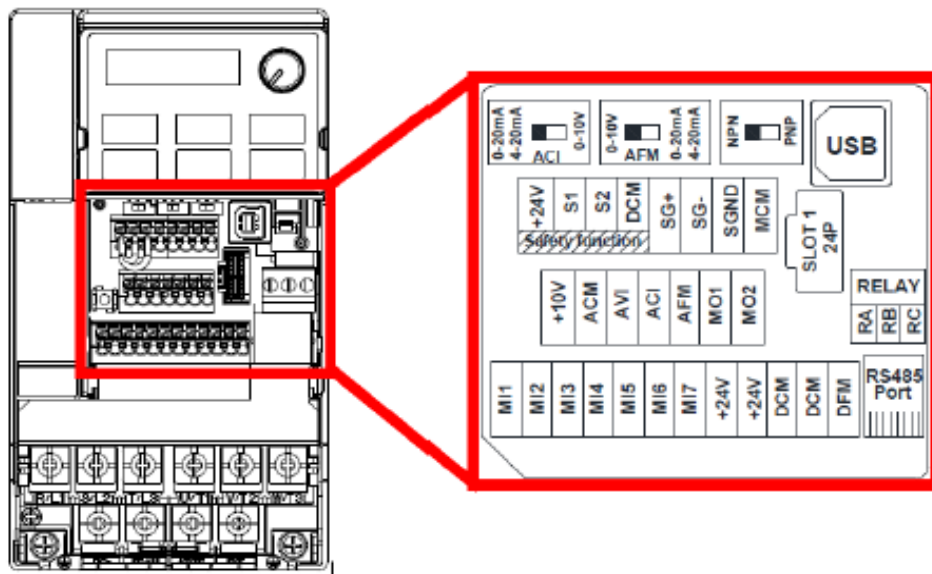

Control Terminations on Variable Frequency Drive

V Series Washer Model	Max Spin Speed	Jumper Terminal Locations on Variable Frequency Drive (VFD)													
		MI1	MI2	MI3	MI4	MI5	MI6	DCM (Left)	DCM (Right)	24V	ACM	AVI	ACI	10V	MO1
T-300, T-400,	60 G											X		X	
T-600, T-900,	80 G				X			X							
T-1200	100 G	Default Setting (No Jumper Required)													
T-350, T-450, T-750	60 G											X		X	
	100 G				X			X							
	140 G					X		X							
	200 G	Default Setting (No Jumper Required)													
T-650, T-1450	100 G											X		X	
	140 G	REMOVE Brown Jumper Between MI5/MO1													
	200 G	Default Setting (No Jumper Required)													

Spin Speed Adjustment Jumper Locations

MAXIMUM SPIN SPEED ADJUSTMENT (T-950 Only)

The variable frequency drive allows for varying acceleration during Final Spin on T-950 models. It is important to utilize a decreased acceleration rate when the application power is low. This acceleration rate is determined by a white wire jumper installed on the drive terminal block from +10V to AVI.

Remove the wire jumper when input power is between 208 and 219 volts. Keep the jumper installed when input power is between 220 and 240 volts. Reference the drawing below for the jumper location.

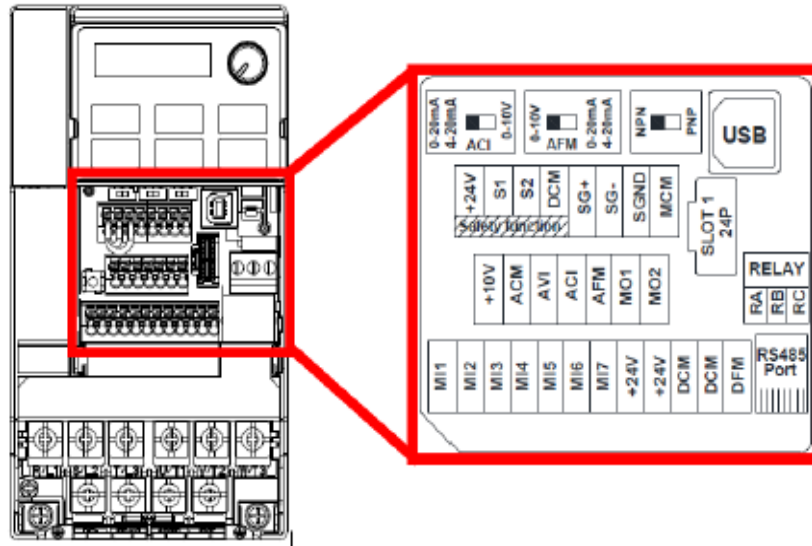

Control Terminations on Variable Frequency Drive

V Series Washer Model	Input Voltage	Max Spin Speed	Jumper Terminal Locations on Variable Frequency Drive (VFD)													
			MI1	MI2	MI3	MI4	MI5	MI6	DCM (Left)	DCM (Right)	24V	ACM	AVI	ACI	10V	M01
T-950	240V	140 G	REMOVE Brown Jumper Between MI5/M01													
		200G												X		X
	208V	140 G	REMOVE Brown Jumper Between MI5/M01													
		200G	No Jumper required													

T-950 Spin Speed Adjustment Jumper Locations

Notes

Lined area for notes



Section 4: Trouble Shooting

Common Troubleshooting Solutions

Symptom	Probable Cause	Suggested Remedy
Machine does not start	Power Supply	Check these areas: Circuit breakers, Voltage, Power leads, Power connections. Is front display LED display lit?
	Door Switch	Check for continuity through door switch when door is closed. If no continuity, adjust or replace door switch.
	Control Breaker or Fuse	Check the 1.5 amp and 2.0 amp fuses (60 hz models) or circuit breaker (50 hz models) for continuity. If no continuity, replace fuse or breaker.
	Control Transformer	Check voltage output from control transformer for 24 VAC and 120VAC (50 hz models have 24 VAC only). If voltage is incorrect, check for proper transformer tap connection or replace transformer.
	Check PCB board	Check all wire connections for sure contacts.
	Check wiring between PCB	Check data cable phone type connectors unplug and VFD and replug with power removed.
	Check Door Lock Mechanism	Check that 120 VAC power (for 60 hz) or 24 VAC power (for 50 hz) is at door lock motor after start button is pressed.
Door does not lock	Check display for fault code	Follow tests described in fault code section.
	Door locking mechanism	Check to ensure that mechanism is receiving 120VAC for 60 Hz. models (or 24VAC for 50 Hz. models) from main relay PCB. If it is receiving power but not functioning, then replace mechanism.
	Door Switch	Check for continuity through door latch switch when door closed. If no continuity, adjust or replace door switch.
Door will not open	Thermoactuator	Check to see if thermoactuator(s) and/or its mechanism is stuck or binding and not allowing the door lock mechanism to open. Check to be sure that the locking thermoactuator is not receiving 24VAC during the last 1 1/2 minutes of the cycle. Also check to see that the unlocking thermoactuator is receiving 24VAC during the last minute of the cycle. If the timing and voltage are correct, replace the thermoactuator.
Door will not open	Door Rod	Check to see that door rod from solenoid to lock ass'y is long enough to allow lock ass'y to disengage. If not, adjust rod.
	Door locking mechanism	Check that door lock mechanism is not stuck closed. If stuck, replace.
No hot water in detergent dispenser	Water Valve Coil	Check coil continuity at terminals and replace if no continuity. 120 VAC power (60Hz) only on for 20 second in wash bath. (24 VAC for 50 Hz models)
	Water Inlet	Check water inlet screens for blockage and clean screens if necessary.
	Water	Check to insure that water is turned on and operating.
	P-20 Wire Harness	Check black & white harness.

Symptom	Probable Cause	Suggested Remedy
Hot water does not enter tub in wash	Water Valve Coil	Check coil continuity at terminals and replace if no continuity. Check for 120 VAC power (60 Hz) from main relay PCB. (24 VAC for 50 Hz models)
	Water Inlet	Check water inlet screens for blockage and clean if necessary screens
	Water	Check to insure that water is turned on and operating.
	Check Voltage	If appropriate voltage is not present at the valve, refer to the wiring diagram for your specific washer model. Check for voltage at the P4 Connector on the Relay PCB. Check for LED indication that the appropriate relay is activated.
	Pressure Switch	Check pressure switch continuity between terminals . If no continuity, check pressure switch hose for obstruction. If hose okay, change pressure switch.
No cold water to tub in wash	Water Valve Coil	Check coil continuity at terminals and replace if no continuity.
	Water Inlet Screens	Check water inlet screens for blockage and clean if necessary.
	Water	Check to insure that water is turned on and operating.
	Check Voltage	If appropriate voltage is not present at the valve, refer to the wiring diagram for your specific washer model. Check for voltage at the P4 Connector on the Relay PCB. Check for LED indication that the appropriate relay is activated.
	Pressure Switch	Check pressure switch continuity between terminal contacts. If no continuity, check pressure switch hose for obstruction. If hose okay, change pressure switch.
Water comes in but level does not rise	Drain Valve (open)	Check these areas: <ul style="list-style-type: none"> • Drain valve blockage • Drain valve motor and gear train. If power but drain valve does not close, replace valve. • Power to the drain valve. If no power to drain valve, check circuit for power.
	Check Voltage	If appropriate voltage is not present at the valve, refer to the wiring diagram for your specific washer model. Check for voltage at the P4 Connector on the Relay PCB. Check for LED indication that the appropriate relay is activated.
Water does not flush softener compartment.	Water Valve Coil	Check coil continuity at terminals and replace if no continuity.
	Water Inlet Screens	Check water inlet screens for blockage and clean if necessary.
	Water	Check to insure that water is turned on and operating.
Water does not flush softener compartment.	Pressure Switch	Check pressure switch continuity between terminals. If no continuity, check pressure switch hose for obstruction. If hose okay, change pressure switch.
Water level too high	Pressure Switch	Check for blockage in pressure switch hose. Check for pressure switch opening circuit across terminals . Replace switch if contacts do not open.
Water drains slowly	Drain System	Check hoses and drain valve for blockage. Clean of inadequate size. If necessary. Check building drains for blockage

Common Troubleshooting Solutions

Symptom	Probable Cause	Suggested Remedy
Machine does not turn	VFD	Check VFD by removing inspection panel and record any numbers or letters displayed. If no display turn power off to machine at breaker for 2 minutes and turn power back on to reset. If still no display replace VFD
Machine tumbles in one direction	VFD	Remove inspection cover at rear and record in only numbers or letters displayed. See fault code section for more info.
	VFD	Inspect yellow enable wires from main relay PCB and at VFD
Excessive vibration	Mounting System	Check these areas: • Strength of mounting structure, concrete or base. • Mounting bolts may be loose and need tightening.
	Drive Belt	Worn drive belt can cause vibration and noise.
	Loading	Note: Small loads contribute to out of balance loading and increase vibration.
Machine does not spin	Pressure Switch	Check pressure switch for continuity across terminals #21 & #22 indicating pressure switch has reset to the empty position. If no continuity, change pressure switch.
Machine starts and does not operate	VFD	Check yellow enable wires from relay PCB P13 & motor P14 to VFD advances through cycle are connected. Check fault code on VFD before removing power from the drive. Check orange P-15 wire for signal from door switches.
Machine does not stop	Main PCB	Main PCB controls time cycle at end of cycle
	Braking Resistors	Check braking resistors for continuity. Verify ohms resistance by Molex.
Water leakage around loading door	Door Adjustment	Door may need adjustment due to abuse or wear. Check tightness around perimeter using a dollar bill. Adjust left to right tightness by shims at door lock or hinge side. It is important to center gasket to tub opening before tightening door to hinge bolts. Chalk may be used on tub front to show point of contact with tub. If gasket is deformed, worn, or damaged, replace. Refer to parts section for door gasket expander kit.

Fault#	Description	Customer Action
HEAT_RISE_OUT_OF_RANGE	Operating temperature is above (target temperature + upper hysteresis) and above 220F (104C)	Check operating thermistor
NO_HEAT_RISE	Operating temperature is below (target temperature + lower hysteresis) and operating temperature has not increased by 2F in 15 minutes	Check operating thermistor Check gas Check combustion
PROX_SENSOR_OUT_OF_RANGE	This error occurs when the machine control sees output from the proximity sensor(s) that does not fall in the acceptable range for the particular washer or dryer model running at normal speeds. It also occurs when the machine control sees output from the proximity sensor that implies the tumbler is still turning when the control has commanded it to Stop.	The machine will not start and the Error Code will continue to be displayed until the prompt is followed to Reset the Error Code and return the Machine to Idle Mode.
NO_PROX_SENSOR_OUTPUT	The RPM is below 10 after the VFD is within 10% of its commanded frequency for 3 seconds	Check belts Check Prox Sensors
BL_COMMAND_ERROR	The control board received a bootloader command but was unable to complete the operation requested	Hold reset button for 10 seconds to force control board into the actual bootloader.
THERMISTOR_SHORT	There is a short circuit across the thermistor terminals or the measured temperature is above 385 degrees F (below 100 ohms).	Check Thermistor connections Check Thermistor resistance
THERMISTOR_OPEN	There is an open circuit across the thermistor terminals or the measured temperature is below -33 degrees F (above 310 Mohms)	Check Thermistor connections Check Thermistor resistance
OH_THERMISTOR_SHORT	There is a short circuit across the thermistor terminals or the measured temperature is above 440 degrees F (below 50 ohms).	Check OH Thermistor connections Check OH Thermistor resistance

Fault#	Description	Customer Action
OH_THERMISTOR_OPEN	There is an open circuit across the OH thermistor terminals or the measured temperature is below -33 degrees F (above 310 Mohms)	Check OH Thermistor connections Check OH Thermistor resistance
DRIVE_COMMUNICATION_ERROR	Failure to reset VFD, communication retry failure over 3 times	Check VFD cable Check VFD power
DRIVE_CRC_MISMATCH_ERR	CRC mismatch in VFD message	Check VFD FW Check VFD cable Check for noise on VFD cable
DRIVE_ENABLE_ERROR	VFD speed still 0 after commanding frequency 3 times	Check VFD enable relay Check VFD enable connector Check VFD enable cable
DRIVE_EXCEPTION_ERROR	Exception received from VFD	Refer to Graphics board for specific exception
SLOW_SPIN_ERROR	VFD frequency is not within 10% of the command frequency after time specified by acceleration type	Check VFD load
DRIVE_RESETTING	Temporary warning indicating that the drive was commanded to reset	Check VFD FW Check VFD cable Check for noise on VFD cable
DRIVE_RESET_COMPLETE	Warning used to indicate a VFD reset was successful	No Action Required
MODEL_DRIVE_SIZE_ERROR	VFD size does not match machine configuration parameters	Check model header Check model configuration
DRIVE_PARAMETER_ERROR	VFD parameters not match machine configuration parameters	Check model header Check model configuration
NON_DEXTER_DRIVE	Failed to validate Dexter Drive	Check VFD model
SPIN_TIME_ERROR	VFD frequency is not 0 after time specified by deceleration type	Check VFD Check Drum
VFD_FAULT	Fault detected on VFD	Check Graphics board for which fault
VFD_HARD_ERROR	Unknown error returned from the VFD	Check VFD

Fault#	Description	Customer Action
PORT_EXP_INIT	Could not initialize port expander(s)	Check I2C connections
PORT_EXP_READ	Could not read port expander	Check I2C connections
PORT_EXP_SET	Could not set output on port expander	Check I2C connections
PORT_EXP_OLAT	Could not latch output on port expander	Check I2C connections Check voltage on output pins of port expander
PORT_EXP_BAD_CONTROL	Control register mismatch on port expander or issue writing to control register	Verify Relay board was not reset without control board
PORT_EXP_FAILURE	Output register mismatch on port expander	Verify Relay board was not reset without control board
MODEL_CONN	Model connector missing or invalid	Check model connector
OVERHEAT_ERROR	Overheat condition detected	Check Overheat thermistor Check operating temperature thermistor
POWER_LOSS_ERROR	Power loss condition detected	Check power cable Check power to control board
SLOW_FILL_ERROR	Water level has not reached desired level when filling for 15 minutes	Check water supply Check water valves Check water valve relays Check pressure sensor

Fault#	Description	Customer Action
SLOW_DRAIN_ERROR	Water level has not reached empty level when draining for 5 minutes	Check water drain Check drain valve Check drain valve relay Check pressure sensor
INVALID_FILL	Fill type specified does not match available types	Contact software engineering. Indicative of software bug or processor malfunction
DOOR_SHUT_NOT_LOCKED	Unable to lock door when starting washer cycle. Unable to keep door locked when running a cycle	Check door lock motor Check door lock relay Check thermoactuators
INCOMPATIBLE_SPIN_SPEED	Spin type specified does not match available types	Potential model mismatch between control board and graphics board, reset machine.
THERMAL_LOCK_FAIL	Unable to hold the door locked when testing between stages	Check thermoactuators
PORT_EXP_I2C_ADDR	Could not find the expected port expander with the proper address configured	Check I2C connections Check Relay Board model connectors P6
INJECTION_ERROR	Improper injection or injection times	Check cycle parameters
INVALID_PARAM	Invalid parameter received from Graphics board	Check model parameters
VFD_RESET_FAIL	Failed to reset the VFD	Check VFD
	VFD speed is outside of 10% window of commanded speed	Check VFD
E_STOP	Emergency Stop button depressed	Check E-stop button

Drive Motor Inverter Type Motor-Winding Resistance Chart

T-675 O-Series Express Washer

Motor	Winding	Wire #	Resistance	
			Minimum	Maximum
T-675 1PH or 3PH 60Hz Main (wash & spin) Dexter #9376-308-001		T1 & T2	2.58	2.58
		T2 & T3	2.58	2.58
		T1 & T3	2.58	2.58

T-975 O-Series Express Washer

Motor	Winding	Wire #	Resistance	
			Minimum	Maximum
T-975 1PH or 3PH 60Hz Main (wash & spin) Dexter #9376-326-001		T1 & T2	0.47	0.47
		T2 & T3	0.47	0.47
		T1 & T3	0.47	0.47

T-1475 O-Series Express Washer

Motor	Winding	Wire #	Resistance	
			Minimum	Maximum
T-1475 1PH or 3PH 60Hz Main (wash & spin) Dexter #9376-328-001		T1 & T2	0.327	0.327
		T2 & T3	0.327	0.327
		T1 & T3	0.327	0.327

NOTE: Resistance values are measured at the stator. Values at the end of the motor wiring harness may be slightly higher.



Section 5:

Machine Service Procedures

Top Panel Removal Top Soap Dish

- Step 1: Remove 4 screws that hold detergent dispenser to top panel. (for T-750, T-900, T-950)
- Step 2: Unlock top panel lock.
- Step 3: Raise top panel, slide to the rear to release from back clips and lift off.

Top Panels Removal Front Soap Dish

- Step 1: Unlock top panel locks.
- Step 2: Raise front top panel, slide forward to release from rear top panel.
- Step 4: Remove 5/16 bolt from hold down brackets, (rear top panel front edge to each side panel.
- Step 3: Raise rear top panel, slide to the rear to release from back clips and lift off.

Front Panel Removal

- Step 1: Remove 2 screws between front panel top and front (located behind control panel).
- Step 2: Remove the two or four screws in the middle of the front panel.
- Step 3: Pull panel out at the bottom to about a 45 degree angle to detach the top lip and remove.

Back Panel Removal

- Step 1: Remove all screws holding back panel in position except the bottom row.
- Step 2: The bottom row of screws are slotted and only need to be loosened and to lift off panel.

NOTE: The back panel is not only a safety requirement but also contributes to the rigidity of the cabinet.

Drain Valve Access

For access to drain valve, remove lower service panel. The drain valve is a ball type and is powered closed by the drain valve motor. It is mounted under the washer tub on the left side. It is spring loaded open. If power is interrupted to the washer, the motor releases the sealing ball, allowing the drive spring to open the valve. With the valve open, all water in the washer will drain out.

Drain Valve Cleaning

- Step 1: Loosen the clamp on the tub hose at the drain valve end and remove the hose from the drain valve.
- Step 2: Loosen the drain hose clamp on the back of the drain valve. Remove two drain valve mounting racket screws from the frame of the washer.
- Step 3: Disconnect red/white & white/red wire connection at clear connector.
- Step 4: Remove the drain valve and bracket assembly. Unplug the wiring after the drain valve is removed from the washer.

Detergent Dispenser (T-750, T-900, T-950)

Remove top panel to access dispenser. (see Removing Top Panel) Detergent is flushed from the front of the compartment and fabric softener is flushed from the back. There will be a small amount of water left in the fabric softener compartment after each use.

Vacuum Breaker (also called an air gap)

In the left rear of the cabinet is the vacuum breaker. It guides the water to the tub and dispenser and prevents a back flow of water.

Water Valves

Remove top panel to access water valves. (see Removing Top Panel) The two dual outlet water and/or single coil valves are mounted to the rear channel with two screws each. Always check inlet screens to be sure that they are clean. Disassembly requires the removal of two solenoid screws and three valve body screws. Below the solenoid coil is a solenoid guide, armature, armature spring and diaphragm. All valve parts are available individually or as a complete unit.

Door Lock Assembly Operation

After loading the clothing, the door should be closed and latched. The locking cam on the door contacts the latching switch actuator which closes the latching switch. The specified number of coins should now be added to start the washer. The solenoid pulls up on the locking pawl by use of a linkage rod. The locking pawl has two jobs. The first is to lock the door. This is accomplished by blocking the locking cam on the door so that it can't rotate to unlock. The second job is to close the two piggyback lock sensing switches. These switches control power to all of the controls. If the door unlocks for any reason, these two switches will stop the machine. When the door handle is 1/4 to 1/2 of an inch from its fully closed position, the latching switch should close. The two piggyback lock sensing switches should be open when the door is unlocked and should be closed when the door is locked.

Accessing the Door Lock Assembly

After removing the front panel and masking ring, the door lock assembly can now be accessed.

Adjustment for Door Lock Assembly

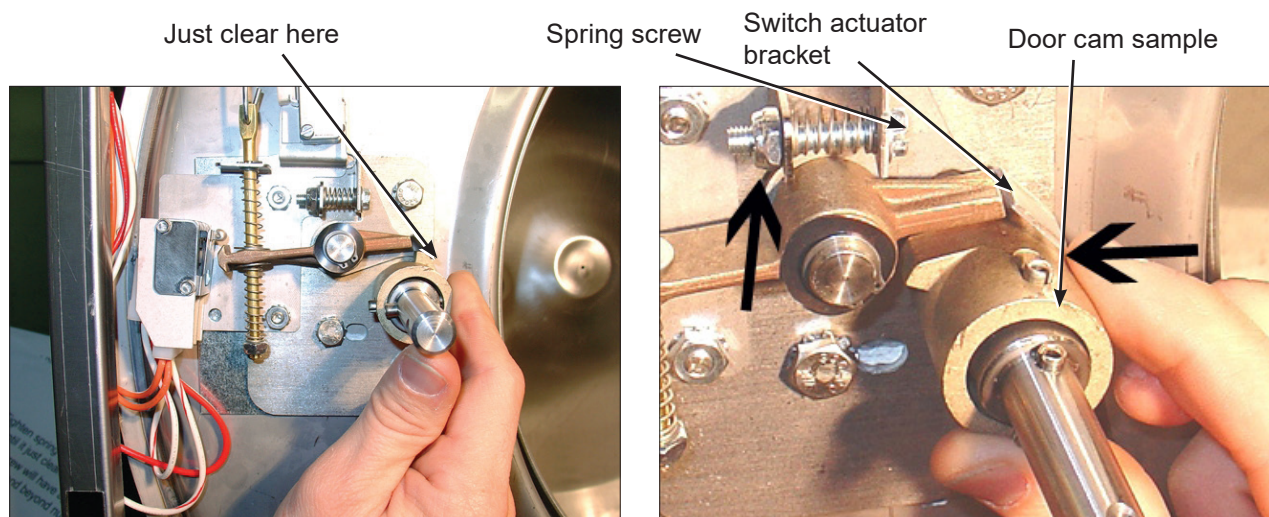

Step 1: Set door cam over pin. Here you can see the door cam away from the door lock assembly.

Step 2: Tighten spring screw on switch actuator bracket arm until it just clears cam OD. at base of door lock assembly.

Adjustment to this bracket usually is not necessary as next step is used more in field.

Flat blade screw on door switch latching

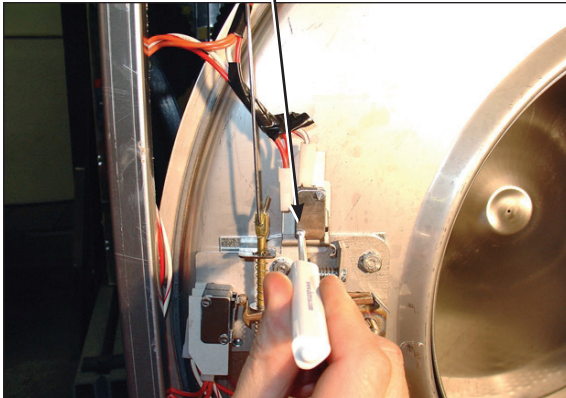

Step 3: With switch actuator bracket adjusted you will now need to adjust single switch by loosening 2 flat blade screws and allowing swivel of switch. Move switch towards above bracket until it actuates. Now tighten flat blade screws. Use a .040 thickness gauge to insert between bracket and switch and the switch should close and open again upon removal of thickness gauge.

Door cam check position

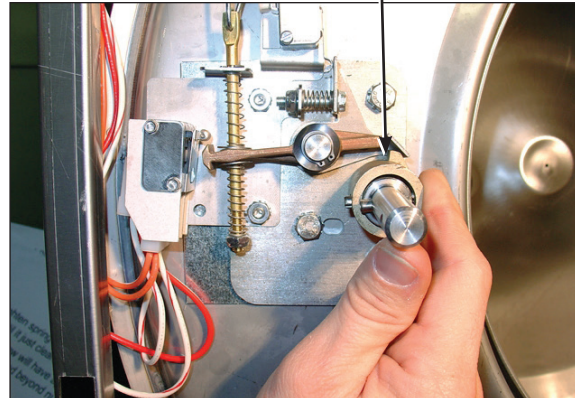

Step 4: Check for switch actuation at partial turn of cam as in operation above. Door handle goes from horizontal to six o'clock vertical.

Door lock rod Locking pawl blocking

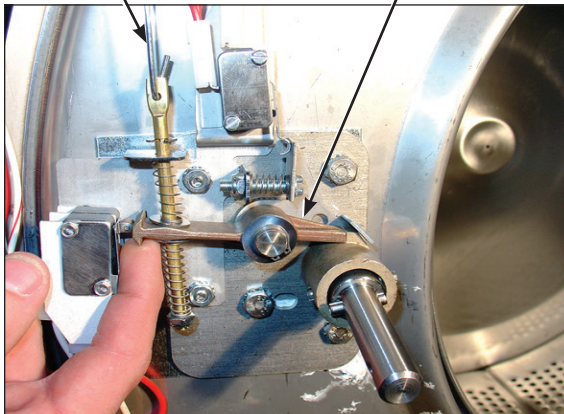

Step 5: Check that lock pawl arm swings to cam lobe to lock position.

Adjustment screw for (piggyback switches)

Top of flat end of locking pawl.

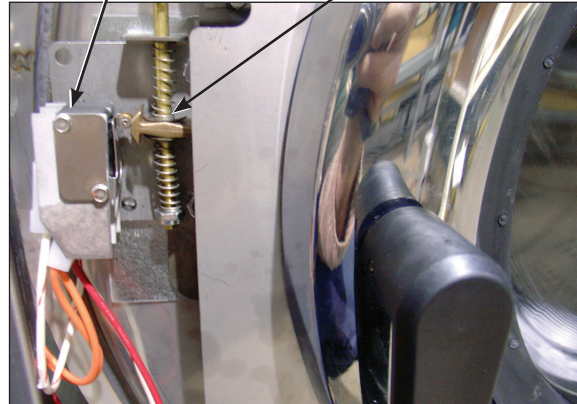

Step 6: The lock stacked switches (piggyback) must be adjusted as door lock solenoid pulls up on door rod and locking pawl is now blocking door cam from turning and is in full up position. The stacked switches (piggyback) have a single actuator arm and it must actuate when single actuator roller wheel rolls to flat side of locking pawl. You will also notice a .040 gap between actuator arm and switch bodies.

Note: Both stacked switches must operate together!

Adjusting the Loading Door

The door can be adjusted by changing the number of shims behind the door hinge and the door lock assembly. The vertical fit of the door to the tub can be altered by loosening the door hinge bolts and raising or lowering the door before retightening. It is important for the door to be centered on the tub front. By chalking the front of the tub and closing the door to transfer that line to the gasket, the centering can be evaluated. It is also important for door pressure to be similar around the door perimeter. Door pressure can be evaluated by inserting a dollar bill in several positions and tugging on it. See Parts Section for kit to increase door sealing pressure.

Loading Door Removal



Step 1: Support door to prevent dropping.



Step 2: Remove 2 bolts holding the lower leaf hinge and set door off.

Loading Door Hinge Removal

Step 1: First remove loading door, front panel, and trim ring.



Step 2: Remove 3 screws holding door hinge. Shims may be present between hinge and tub front. The number may be increased or decreased to adjust right side door pressure.

NOTE:

Door hinge mounting bolts penetrate tub front and require silicone sealer applied to holes when reinstalling.

Loading Door Disassembly

Step 1: Remove the loading door as outlined above. Lay the door on a flat surface with the glass down

Step 2: While holding down on the door glass, lift up on the door ring and roll back the lip of the gasket with your fingers.

Step 3: Work all the way around the gasket and the glass is out.

Loading Door Reassembly

Step 1: Lay the door ring face down on a flat surface. Start the glass into one side of the door gasket.

Step 2: Use one hand underneath to push the gasket out and the other hand on the top pulling the gasket in place

Step 3: The front lip of the door gasket should be checked for proper seating.

Control Panel Name Plate Decal

The name plate on washer front is adhesive backed.

Control Panel Name Plate Removal

The name plate may be removed by simply peeling it off.

Re-Installation of Name Plate

Step 1: Remove any remaining glue from the control panel.

Step 2: Before removing the paper backing from the name plate, check fit to the control panel. The program push buttons are the locating guides.

Step 3: Remove the paper backing from the right side of the name plate, position it on the panel and press right end into place. Peel the backing from the left end and press into place.

Door Locking Gear Motor Assembly

The door locking gear motor is rotated shut with control voltage to lock the door and releases when voltage is removed. It is located in the left front corner of the washer. (Original locking solenoid models can be converted to the new assembly)

Thermoactuators

The thermoactuators are a safety device that keeps the door from immediately unlocking if power is lost while the machine is operating. They are mounted under the door locking solenoid.

Lock Thermoactuator

Control voltage is applied to the lock thermoactuator at the beginning of the cycle making it extend and block the door locking gear motor. This keeps the door locked for approximately two minutes after a power failure occurs. The lock thermoactuator does not delay the door opening at the end of a normal cycle.

Unlock Thermoactuator

To insure that the lock thermoactuator has retracted by the end of the cycle, one minute prior to the end of the cycle, the unlock thermoactuator is powered with control voltage making it extend and unblock the door locking gear motor.

Drive Belt Removal

Turn the drive pulley while applying pressure to the drive belt until it rolls off of the basket pulley first and then remove from the motor pulley. Be cautious not to drop the motor which could unhook the tension assembly.

Reverse this procedure for installation.

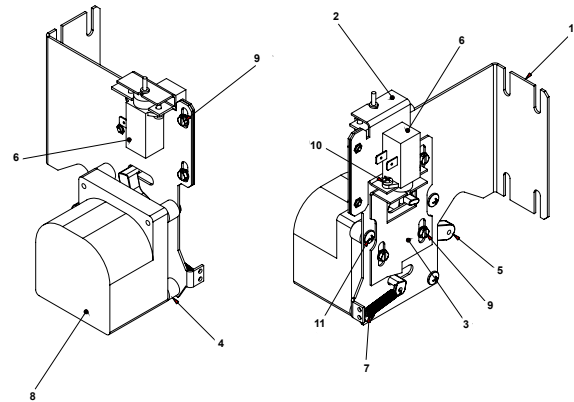

Door Lock Gear Motor

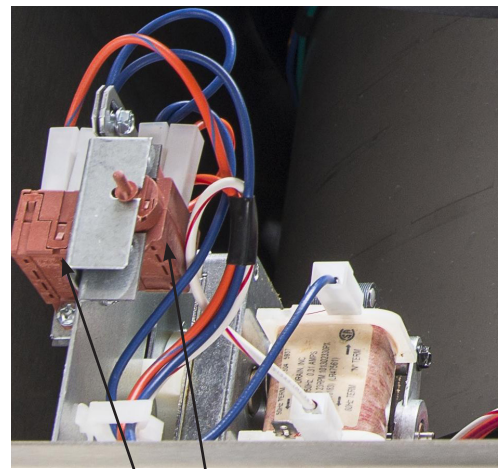

Thermoactuators



Drive Belt

Cylinder (basket)

- Step 1: Remove the top panel as described previously.
- Step 2: Remove lower service panel as described previously.
- Step 3: Remove front panel as described previously.
- Step 4: Remove masking ring as described previously.
- Step 5: Remove door lock assembly. (Leave wires & pull rod in place)
- Step 6: Remove clothes door.
- Step 7: Remove tub front clamp ring.
- Step 8: Remove tub front. Use a flat screw driver to pry the tub front loose.
- Step 9: Remove the rear access panel.
- Step 10: Remove the drive belts.
- Step 11: Remove drive pulley. Remove 3 retaining screws. Insert (3) 3/8 16 x 2" screws into the threaded removal holes. Alternately tighten these screws evenly to pull the pulley off.
- Step 12: Remove pulley hub. Drive a flat screw driver into the slot in the hub and pull it from the shaft.
- Step 13: Install cylinder puller. (Snap On part #CJ-84-C) Be sure to thread a 5/8-11 NC bolt into the end of the cylinder shaft to protect the threads. Push the basket out.

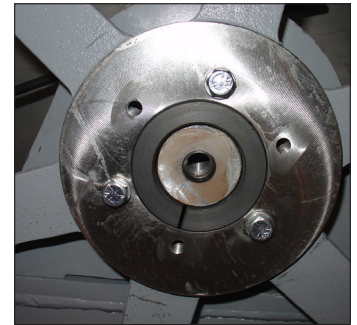
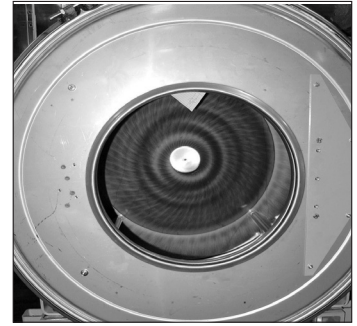

Bearing Housing Assembly

Removal

- Step 1: Remove cylinder from washer (see Cylinder (basket) removal).
- Step 2: Remove 6 7/16" tub back to bearing housing cap screws.
- Step 3: Remove 6 3/4" bearing housing to frame bolts.
- Step 4: Remove bearing housing from frame.
- Step 5: Remove the retaining ring next to the front bearing.
- Step 6: The bearings are pressed into the housing and must be pressed back out.

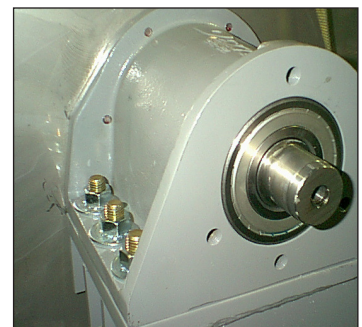

Reassembly

- Step 1: When installing new bearings into a bearing housing, first press the front (large) bearing into the housing until it bottoms and install the snap ring. With the bearing spacer in place, press the rear bearing in until the spacer is snug between the two bearings.

NOTE: If the tub-back water-seal mating ring has been moved it must be cleaned and resealed



Water Seals

Replacement

- Step 1: Remove cylinder from washer (see Cylinder (basket) removal).
- Step 2: Remove water seals from the seal mounting plate on the cylinder shaft. These are removed with your fingers.
- Step 3: The primary and secondary seals that mount on the sealing ring may be slid over the shaft and seated on the metal sealing ring with your fingers. In the unlikely event that the metal ring that mounts these sealing rings were to be damaged or moved, a new one would need to be pressed on. The seal mounting ring must be pushed against the stop on the shaft. After installing the seals, lubricate the faces of the seals with silicone grease.
- Step 4: Install cylinder (see Cylinder (basket) reassembly).

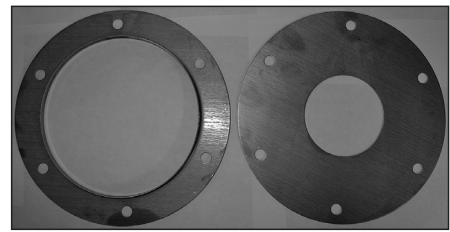

Guard Ring & Mating Ring

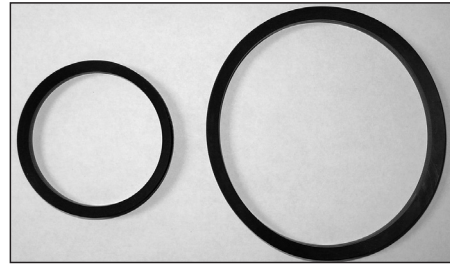

Seals

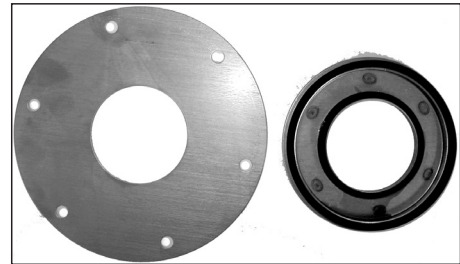

Mating Ring & Mounting Ring

Outer Tub

Removal

- Step 1: The outer tub can easily be removed when the tub front, cylinder and bearing housing has been removed as outlined previously.
- Step 2: At that point the only attachments to the chassis are the two front strap mounting bolts.

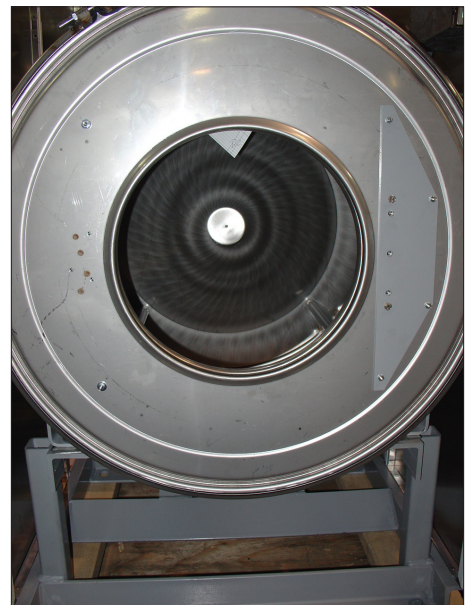

Reassembly of the Cylinder

- Step 1: Use the hub of the drive pulley, a stack of 5/8" flat washers and a 3" long 5/8" bolt to pull the cylinder shaft through the bearings. After the 3" bolt a 2" long bolt will be required to finish pulling the cylinder shaft through.
- Step 2: Remove the 1/2" bolt and nut from the top of the outer tub clamping band.
- Step 3: Install Dexter Tool part # 8545-056-001 on the back of the outer tub to adjust tub front to cylinder clearance. Thread 5/8" bolt through tool and into cylinder shaft. Push the outer tub forward 1/4" to 1/2" with tool 8545-056-001 by tightening the 5/8" bolt. This will ease the installation of the outer tub front.
- Step 4: Clean the silicone rubber off the tub front and the outer tub.
- Step 5: Install new bead of silicone rubber on tub front.
- Step 6: Install tub front.
- Step 6A: Align hole in top of tub front with notch in top of outer tub.
- Step 6B: Use 4-6 #11R vise grip clamps to hold tub front to outer tub. A rubber mallet may be needed to properly seat the tub front into the outer tub.
- Step 6C: Install tub front gasket around outer edge of tub front and outer tub flange. The opening should be centered at the top.
- Step 6D: Remove vise grips. The tub front gasket will hold the tub front in place.
- Step 7: Install tub front clamp ring and tighten. Tap around the clamp ring with a rubber mallet to seat the ring and gasket while tightening the clamp ring bolt.
- Step 8: Adjust clearance between the outer tub front and the front lip of the cylinder to 5/16".
- Step 9: Tighten the outer tub clamping band.
- Step 10: If necessary, the outer tub may be adjusted up or down and side to side with the 2 bolts that fasten the bottom of the outer tub clamping band to the frame.
- Step 11: Remove Dexter Tool part 8545-056-001 from the back of the outer tub.
- Step 12: Install drive pulley.
- Step 12A: Install hub on cylinder shaft.
- Step 12B: Hold hub against rear bearing with 5/8" bolt and flat washer in end of cylinder shaft.
- Step 12C: Line up 3 unthreaded holes in pulley with the 3 threaded holes in hub.
- Step 12D: Insert 3 pulley bolts and tighten evenly alternating bolts to 30ft/lbs.
- NOTE:** Overtightening or uneven tightening can break drive pulley.
- Step 13: Install drive belts & back panel.
- Step 14: Install door lock. All mounting holes should be sealed with silicone rubber.
- Step 15: Install door, masking ring, front panel, lower service panel and top.

T-675 Bolt Torque Chart

Bolt Part Number	Bolt Size	Where Used	Torque	Qty.
9545-017-013	1/2-13 x 2"	Tub Feet to Base	70-110 ft-lb	2
9545-029-009	3/8-16 x 3"	Front Clamp Ring Ends	100-120 in-lb	1
9545-059-004	7/16-14 x 1"	Bearing Housing to Tub Back	60-80 ft-lb	6
9545-057-002	3/4-10 x 3"	Bearing Housing to Base	200-300 ft-lb	6
9545-060-004	5/8-11 x 2"	End of Shaft	100-125 ft-lb	1
9545-029-011	3/8-16 x 2"	Drum Pulley Bushing	28-32 ft-lb	3
9545-018-024	1/4-20 x 1"	Motor Pulley Screws	80-90 in-lb	3
8640-413-006	#10-32	Soap Box Nuts	10-20 in-lb	6

T-975 Bolt Torque Chart

Bolt Part Number	Bolt Size	Where Used	Torque	Qty.
9545-017-013	1/2-13 x 2"	Tub Feet to Base	70-110 ft-lb	2
9545-029-009	3/8-16 x 3"	Front Clamp Ring Ends	100-120 in-lb	1
9545-059-004	7/16-14 x 1"	Bearing Housing to Tub Back	60-80 ft-lb	6
9545-057-002	3/4-10 x 3"	Bearing Housing to Base	200-300 ft-lb	6
9545-060-001	5/8-11 x 1.5"	End of Shaft	100-125 ft-lb	1
9545-029-011	3/8-16 x 2"	Drum Pulley Bushing	28-32 ft-lb	3
9545-018-024	1/4-20 x 1"	Motor Pulley Screws	80-90 in-lb	3
8640-413-006	#10-32	Soap Box Nuts	10-20 in-lb	6

T-1475 Bolt Torque Chart

Bolt Part Number	Bolt Size	Where Used	Torque	Qty.
9545-017-013	1/2-13 x 2"	Tub Feet to Base	70-110 ft-lb	2
9545-029-009	3/8-16 x 3"	Front Clamp Ring Ends	100-120 in-lb	1
9545-059-004	7/16-14 x 1"	Bearing Housing to Tub Back	60-80 ft-lb	6
9545-066-001	7/8-9 x 3.5"	Bearing Housing to Base	600-650 ft-lb	6
9545-057-004	3/4-10 x 1.5"	End of Shaft	100-130 ft-lb	1
9545-029-011	3/8-16 x 2"	Drum Pulley Bushing	28-32 ft-lb	3
9545-018-024	1/4-20 x 1"	Motor Pulley Screws	80-90 in-lb	3
8640-413-006	#10-32	Soap Box Nuts	10-20 in-lb	4



Section 6:

Service Electrical Components

Control Mounting Trough

Remove top panel to access control trough. It sets on the right side of the machine and holds the control PCB's, transformers, and pressure switch.

Main Data Communication Cable

Goes between front PCB board and Variable Frequency Drive unit mounted center rear of machine. It has telephone type connectors at each end and is inserted at Controller PCB and the Variable Frequency Drive.

Circuit Breaker/Fuse

The fuse (optional circuit breaker) mounts to the rear channel. It carries all of the controls in the machine but does not include the motor. To reset the circuit breaker just push in the button. If you have a fuse then remove fuseholder and fuse and replace with a 1 1/2 amp fast blow type fuse.

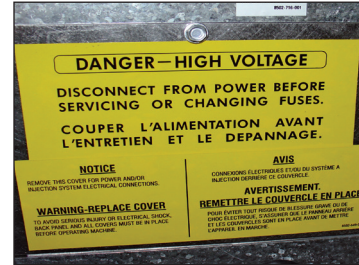

Fuse Location

Main Control Printed Circuit Board

Please be sure to be grounded to machine before removal of this board from machine. PC board mounted vertically behind front control panel. Remove hold down nuts in 4 corners and 1 at bottom center.

Controls Transformer

This transformer is mounted at the back of the control trough and steps a range of 208 to 240 volts down to 120VAC and 24VAC. There are two terminals on the controls transformer for incoming power. One terminal tap is marked for 208 volts use this tap for measured voltage of 200 volts - 215 volts and the other tap is marked 230 volts for 216 volts - 240 volts. NOTE: All washers have a controls transformer. Always check the incoming voltage and use the appropriate transformer terminal when installing ALL washers.

Main Relay Printed Circuit Board

Please be sure to be grounded to machine before removal of this board. PCB mounting horizontal in control trough towards front of machine. Remove 4 mounting nuts.

LED Printed Circuit Board Temperature & Start Display/Push-Button

The selector switch is mounted in the right hand side of the control panel and is held in place with five nuts. It allows the selection of hot, warm, or cold water temperatures. NOTE: Do not over tighten on reinstallation as the switch can be damaged, staying pushed in and will cause erratic displays.

Pressure Switch

The pressure switch sets the water level in the washer. As the water level rises, it compresses the air in the pressure switch hose. When the washer reaches the desired water level, the compressed air in the pressure switch hose opens the contacts in the switch, shutting off the water. When at the empty level, the pressure switch contacts are closed allowing the machine to either spin or fill with water.

Power Connection Terminal Block

This terminal block sets at the very back of the control trough. Incoming power to the washer should connect here. (see Electrical under Installation and Operation Section for exact connections)

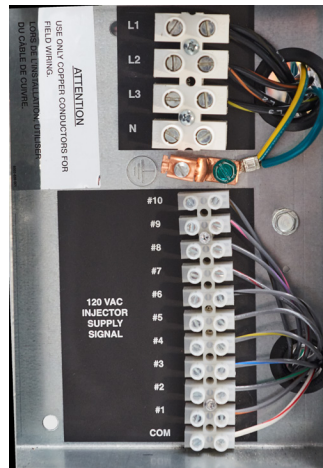

Rear

Delta Variable Frequency Drive:

Main power is connected to terminals L1, L2, and L3 on the Delta drive. If the washer is connected to a three phase source, there should be voltage present on all three terminals. If the washer is connected to single phase power, there should be voltage present on terminals.

The voltage should measure 208 Volts to 240 Volts A.C. between phases and connected to if connected to three phase). There is a tolerance of + 10% on the mains voltage (187 Volts to 264 Volts).

Delta VFD Motor Leads:

The wires from the motor are connected to terminals T1, T2, and T3. Since this drive uses pulse width modulation, an accurate current or voltage reading is not possible. Although an accurate current reading is not possible, a balanced current reading should be present while the motor is running.

Delta VFD Dynamic Braking Resistors:

Two, 160 Ohm or 200 Ohm braking resistors (Please check your washer model parts requirements and quantities), are connected in parallel and attached to the drive at terminals B1 and B2. These resistors allow voltage, which is generated by the motor when decelerating, to be dissipated. They will become hot while the motor is slowing down, so care should be taken so as not to come in contact with them. This will prevent an electrical shock and/or a physical burn.

Delta VFD Cooling Fan:

There is a cooling fan attached to the bottom of the Delta drive. This fan will operate when the internal temperature of the drive reaches a predetermined level, the same way the radiator fan in a newer car operates. THE FAN CAN OPERATE ANYTIME POWER IS APPLIED TO THE DRIVE! Remove power to the drive if work is required around the fan.

Electronic Pressure Sensor

The Electronic Pressure Sensor comes standard on all models. The Pressure sensor is adjustable. The Factory settings chart will let you know the starting values for each machine and by following the Switch position chart you can adjust the water levels in 1/4 inch increments from that starting value.

Factory Settings:



Model	Vended		On-Premise	
	Switch #1 Efficient	Switch #2 Classic	Switch #1 Low Level	Switch #2 High Level
T-300	5.25	7.00	6.00	6.75
T-350	5.25	6.25	6.00	6.75
T-400	7.00	9.00	8.00	11.00
T-450	6.00	6.25	6.00	8.50
T-450 SWD	5.00	7.00	6.00	8.50
T-600	7.25	9.25	8.00	11.00
T-650	6.50	8.25	8.00	11.00
T-750	6.00	7.50	6.00	8.75
T-900	6.00	7.50	6.00	8.75
T-950	6.00	7.50	6.00	8.75
T-1200	6.00	7.50	6.00	8.75
T-1450	6.75	7.00	6.75	9.50

Switch Positions:

Depth (in):	Pos 1	Pos 2	Pos 3	Pos 4	Pos 5	Pos 6
5.00						
5.25	on					
5.50		on				
5.75	on	on				
6.00			on			
6.25	on		on			
6.50		on	on			
6.75	on	on	on			
7.00				on		
7.25	on			on		
7.50		on		on		
7.75	on	on		on		
8.00			on	on		
8.25	on		on	on		
8.50		on	on	on		
8.75	on	on	on	on		
9.00					on	
9.25	on				on	
9.50		on			on	
9.75	on	on			on	
10.00			on		on	
10.25	on		on		on	
10.50		on	on		on	
10.75	on	on	on		on	
11.00				on	on	
11.25	on			on	on	
11.50		on		on	on	
11.75	on	on		on	on	
12.00			on	on	on	
12.25	on		on	on	on	
12.50		on	on	on	on	
12.75	on	on	on	on	on	
13.00						on
13.25	on					on
13.50		on				on
13.75	on	on				on
14.00			on			on
14.25	on		on			on
14.50		on	on			on
14.75	on	on	on			on
15.00				on		on



Section 7:

Electrical Wiring Diagrams & Schematics

Electrical Path Circuit Schematics

Start Circuit

Power travels into the machine on L1, L2, and (L3 if 3 phase used). Power from the L1 & L2 supplies power to the 12VDC power supply. This power being sent to the Control PCB. 115VAC, 24VAC, and the VAC Neutral is created by the control transformer. The 115VAC and 24VAC is being sent to the Terminal Blocks. Power from the L1 and L2 also supplies power to the 12VDC power supply. The 12VDC power is sent directly to the Control PCB on the blue wires.

- All 115VAC power is designated in the machine by red wire connections and the 115VAC neutral is designated by white wires with a red stripe. All 115VAC begins at the terminal block for 115VAC supplied through a control fuse located next to the terminal strip.
- All 24VAC power is designated in the machine by orange wire connections and the 24VAC neutral is designated by white wires with an orange stripe. All 24VAC begins at the terminal block for 24VAC supplied through a control fuse located next to the terminal strip.
- All 12VDC power is designated in the machine by blue wire connections and the 12VDC ground is designated by white wires with a blue stripe.

Closing the door will engage the door hinge closed switch, sending the J11-5, 12VDC to the blue/white wire and over to the S1 door latched switch. Turning the door handle to the vertical latched position closes the primary door latched switch, returning the 12VDC voltage to the main control PCB on the blue/orange wire at the J11-2 connection. This proves the door is closed and latched and ready for safe operation.

A 12VDC signal to J11-2 of the Control PCB and 120vac at the J4-14 of the relay PCB makes 120vac available to the K9 door lock relay. A continuous 5VDC signal is sent out on the J11-6 brown wire and returned on the brown/white wire to the J11-3 connector of the control PCB. This is passed through the (normally closed) emergency stop button switch.

The Washer is ready for operation.

The cycle is selected using the up and down buttons. The start button is now pressed. The control signals the relay board to close relay K9 sending 120VAC to the door lock on the red/brown wire. The door lock motor engages and pulls up on the door locking rod which locks the door and closes the S3 and S4 door locking switches. This sends the 12VDC signal back to the control at J11-1 on the blue/grey wire. This 12VDC also pulls in the K4 relay which sends 24VAC to the normally closed K2 relay that powers the Locking Thermoactuator to expand and block the locking mechanism. At the same time the K5 relay is engaged sending an enable signal to the variable frequency drive. 120VAC will go to the door lock assembly from the P17 connector of the relay PCB on the red/brown wire. The door lock motor engages and pulls up on the door locking rod, locking the door and closing the S2 and S3 door locking switches. The Locking Thermoactuator receives 24VAC on the orange/green wire and will expand to block the locking mechanism.

NOTE: If the door locked signal is not received after one second from pressing the Start button, no motion occurs and the error message "DOOR SHUT, NOT LOCKED" will appear on the display. The washer will not restart until the power is removed and re-applied.

The door lock gear motor will test the door locking circuit 10 seconds before the end of the first stage. The control will release the 120VAC to the red/brown wire which will cause the Gear Motor to release which tests the Locking Thermoactuator safety circuit. This release will last for 10 seconds. As long as the Thermoactuator has properly extended to block the door locking mechanism, the machine will continue as normal.

Agitation Circuit

When the 12VDC signal closes the K5 in the Control PCB it closes the loop in the yellow wire from the VFD terminal MI6 back to the DCM on the white/yellow through the stop button. This enables the Drive to operate and allow motion. If the K5 is not closed or the Aux Stop Button is engaged there will be no motion. A proximity sensor is used to verify that the cylinder is turning when the VFD is commanded to operate. If the VFD frequency is greater than 0 Hz and the proximity sensor has no change in output for 10 seconds, the error code "NO PROX SENSOR OUTPUT" is displayed. The K7 Closes supplying 120VAC on the red/brown to energize the Drain Valve. This supplies power to close the valve. The main control PCB sends data commands to the VFD through the data cable connected at P-2. These commands control all wash cylinder movement. The type of agitation is programmed in the control settings.

- o Agitation type: Normal, delicate, or 3 custom options
- o Agitation time
- o Spin speed
- o Spin time

Fill Circuit-Warm Stage

During the machine fill, a 12VDC signal is sent on the blue wire from the J8-1 connection of the main control PCB to the pressure switch common contacts. This 12VDC returns on the blue/yellow wire for low level and blue/red wire for high level.

NOTE: Unlike the other previous Dexter washers, with O-Series Controls the empty signal is an open circuit, full is a closed circuit.

The washer fills the tub through the back of the machine with either one or both the C1/C3 cold and H1/H3 hot water fill valves. From the P4 connection of main relay PCB, 120VAC is sent out of the K4 relay on the red/pink wire to the C1/C3 cold water fill valve. 120VAC is sent out of the K1 relay on the red/grey wire to the H1/H3 hot water fill valve depending on the programmed bath temperature. If the washer does not initially reach low water level within 7 minutes the cycle will continue and "SLOW FILL ERROR" will be displayed alternately with the Cycle Progress screen. (This is the case unless "None" is chosen for fill level). The alternating "SLOW FILL ERROR" will be displayed the rest of the cycle even when the "CYCLE DONE" screen is displayed. It will reset when the user opens the door.

If the "SLOW FILL ERROR" occurs after 7 minutes and the water level is still not met at 15 minutes, the washer will come to a controlled stop. The current stage will end, and the cycle will not continue. The "SLOW FILL ERROR" will be displayed on the screen until reset. Even on high fill, as long as the low water level is met one time during a stage, the "SLOW FILL ERROR" will not be displayed during the remainder of the stage. This includes if the low water level is met before 7 minutes, then drops again and requires additional filling.

Soap Dish flush / Injection Signals

The signal for the Detergent, Softener, or Injection Signals are programmable to engage for 0 to 150 seconds. By setting up the injection or flush in the programming, a 120VAC signal will be sent from the main or secondary relay board to a specific flush valve or injection terminal on the back of the machine. The Hot Detergent flush is powered from the Red/Black of the main relay board. The Cold Softener flush is powered from the Red/Violet of the main relay board. All Injection Terminal Strip signals are powered from the Grey wires of the secondary relay board. All 120VAC neutral is carried through the white/red wires.

The Detergent Flush, Softener Flush, or Injection Signal start time is selectable from 0 to 150 second delay. The start time of the delay count down is dependent on the settings of the Delay Fill option. This Delay Fill option is a global setting which affects all stages of all cycles. The default setting is Delay Fill enabled which means that the Compartment flush or injection signal delay time will not start counting down until AFTER the low level fill has been achieved. (If the setting is changed to "disabled", then the countdown will begin from the beginning of the stage.

Level Achieved / Stage Completion / Drain

When the water level in the basket reaches the preset level pressure, the switch moves its switch contacts to the full or closed position. This causes the main control PCB to signal the relay PCB to shut off the water valve coils. Once the machine has achieved its water level, the wash cylinder will continue to agitate as programmed. The time on the front display will count down as the stage progresses. The time of the stage is programmable up to 30 minutes per stage used.

When the bath ends the control PCB signals the relay PCB to remove 120 VAC power from red/white wire at J4-3 going to the drain valve. With voltage removed, the normally-open, spring-loaded drain valve will open allowing water to exit the machine until the tub is empty. This resets the pressure switch back to an (open contact) empty level and removes the 12VDC connection through the pressure switch from the blue wire to the blue/yellow and blue/red wires. The same options can be set for each stage through. It is possible to hold the drain valve and keep the bath water in the tub to start the next stage or extend the stage time.

NOTE: The control can be programmed to hold the drain and extend advance into the next stage. This allows for roll over stage possibilities.

Spin and Extract Circuit

Once the pressure switch achieves empty (open circuit) level, the washer is capable of a programmed spin speed, from 60 to 200 G-Force at the end of each stage. The control PCB sends a signal to the variable frequency drive via the data cable from P-6 to the VFD RJ-11. The rotation as viewed from front during spin will be counter-clockwise. At the end of the spin, the basket will come to a stop with the assistance of the dynamic braking resistors wired in parallel to the variable frequency drive. The washer will then tumble for 45 seconds to let the clothes shake loose from the basket and then stop.

Thermoactuator and Shake Out Circuit

The Lock Thermoactuator is turned off after deceleration from the final spin is complete and just before the additional 3 agitation motions ("shakeout" portion) are beginning. Deceleration from final spin is considered to be complete when the VFD is registering 0 Hz for actual frequency and the control is registering less than 10 RPM from the proximity sensor for 10 seconds. Both of these conditions must be satisfied for the Unlock Thermoactuator to turn on. Once powered this will push the safety block mechanism out of the way of the door lock gear motor lever.

End of Cycle Circuit

Once the machine stopped, 3 things occur:

- 1st) The beeper will signal for 5 seconds letting the user know that it is the end of the cycle.
- 2nd) The control PCB signals the relay PCB to remove power from the red/brown wire at J4-6 which allows the door lock gear motor to unlock.
- 3rd) The main control PCB resets when the S1,S2,S3, and S5 opens and door is opened, allowing the display to reset when door is opened.

WN0675XB-12EO Schematic

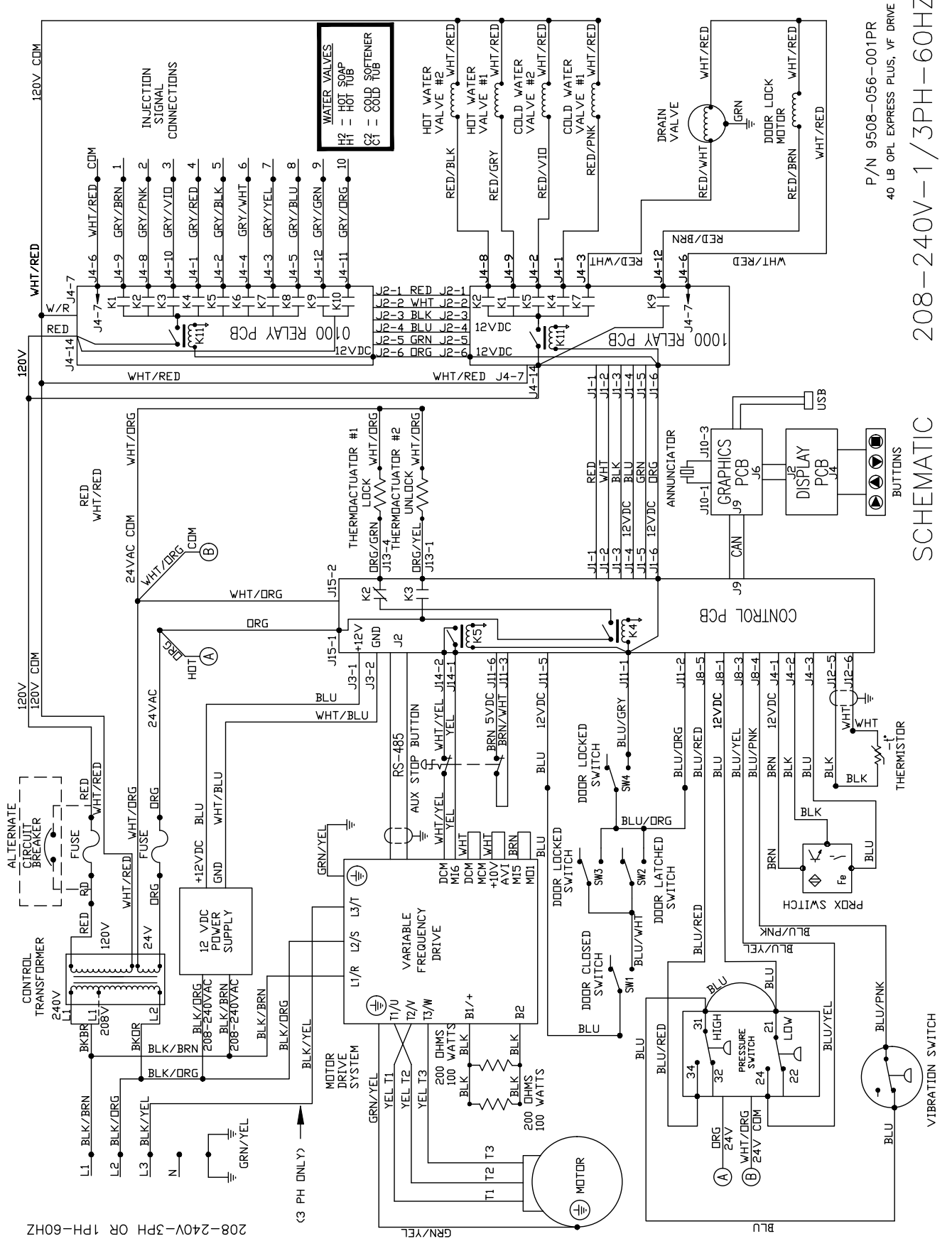

208-240V-3PH OR 1PH-60HZ
 (3 PH ONLY)

P/N 9508-056-001PR
 40 LB OPL EXPRESS PLUS, VF DRIVE

SCHEMATIC

208-240V-1/3PH-60HZ

WN0675XB-12EO Diagram

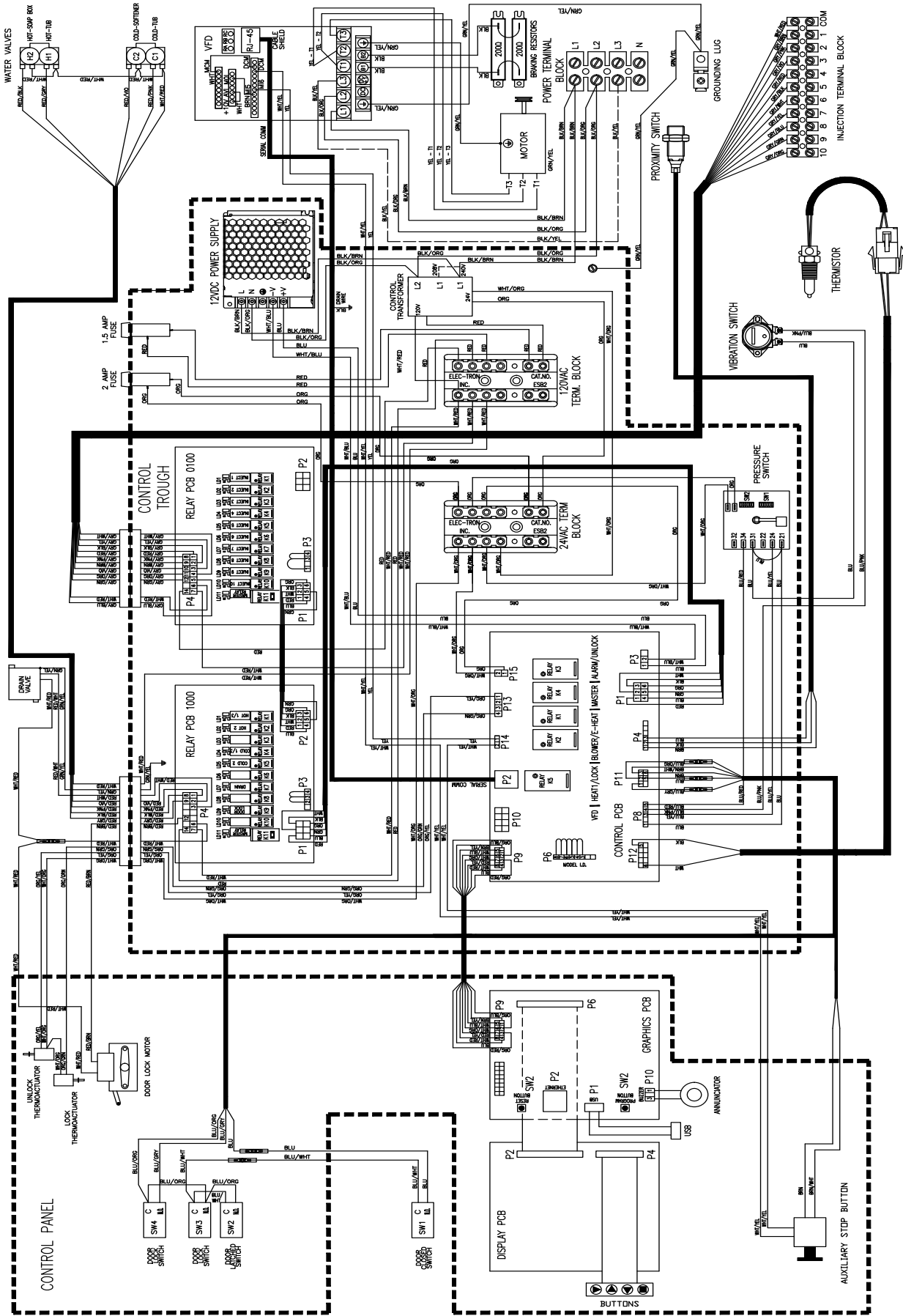

P/N 9507-056-001PR
 40 LB OPL EXPRESS PLUS, VF DRIVE
 WN0675XB-12_02X-_____X

WIRING DIAGRAM 208 - 240V, 1/3PH, 60HZ

WN0975XB-12EO Schematic

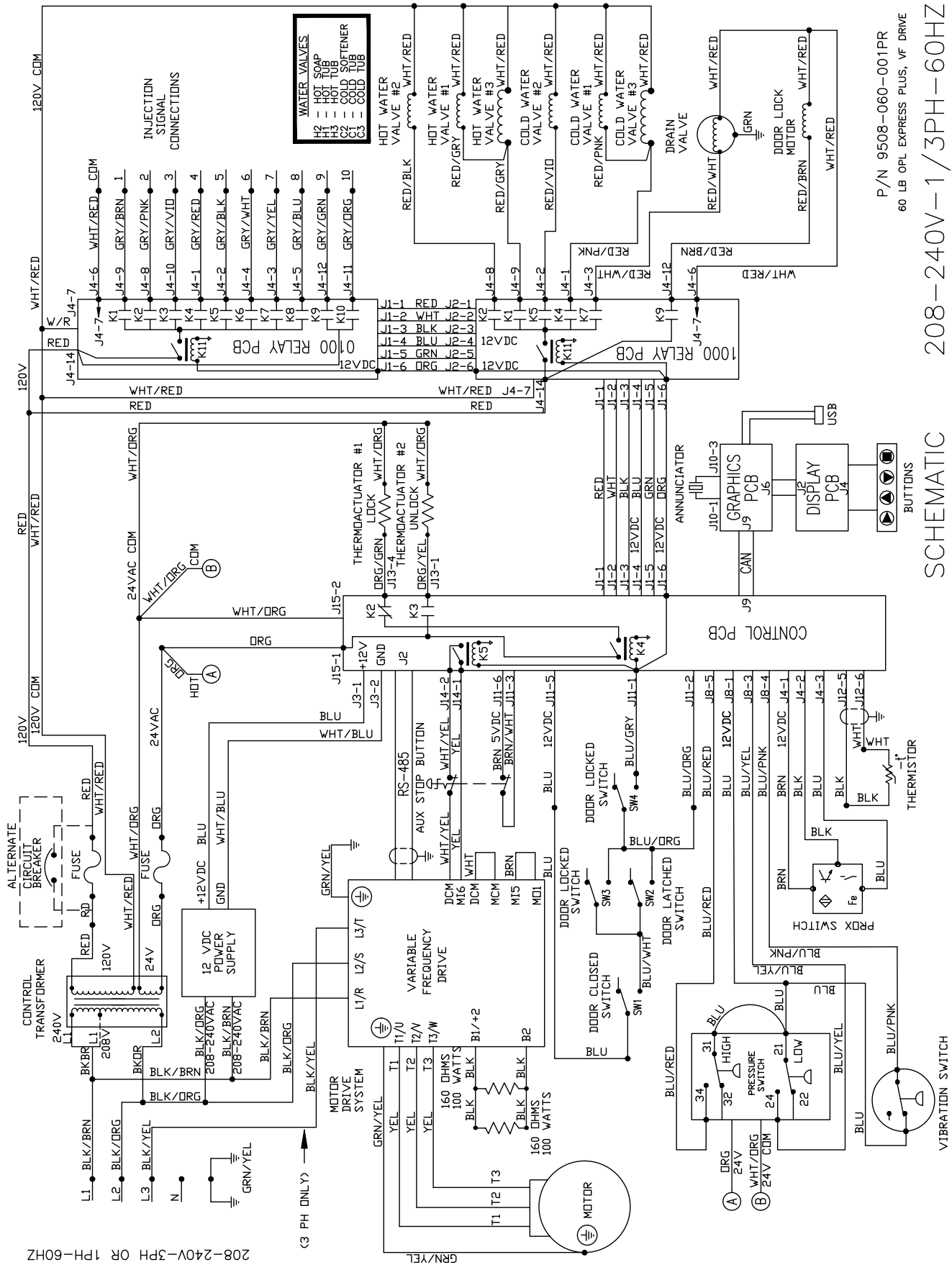

208-240V-3PH OR 1PH-60HZ

(3 PH ONLY)

P/N 9508-060-001PR
60 LB OPL EXPRESS PLUS, VF DRIVE

SCHEMATIC

208-240V-1/3PH-60HZ

WN0975XB-12EO Diagram

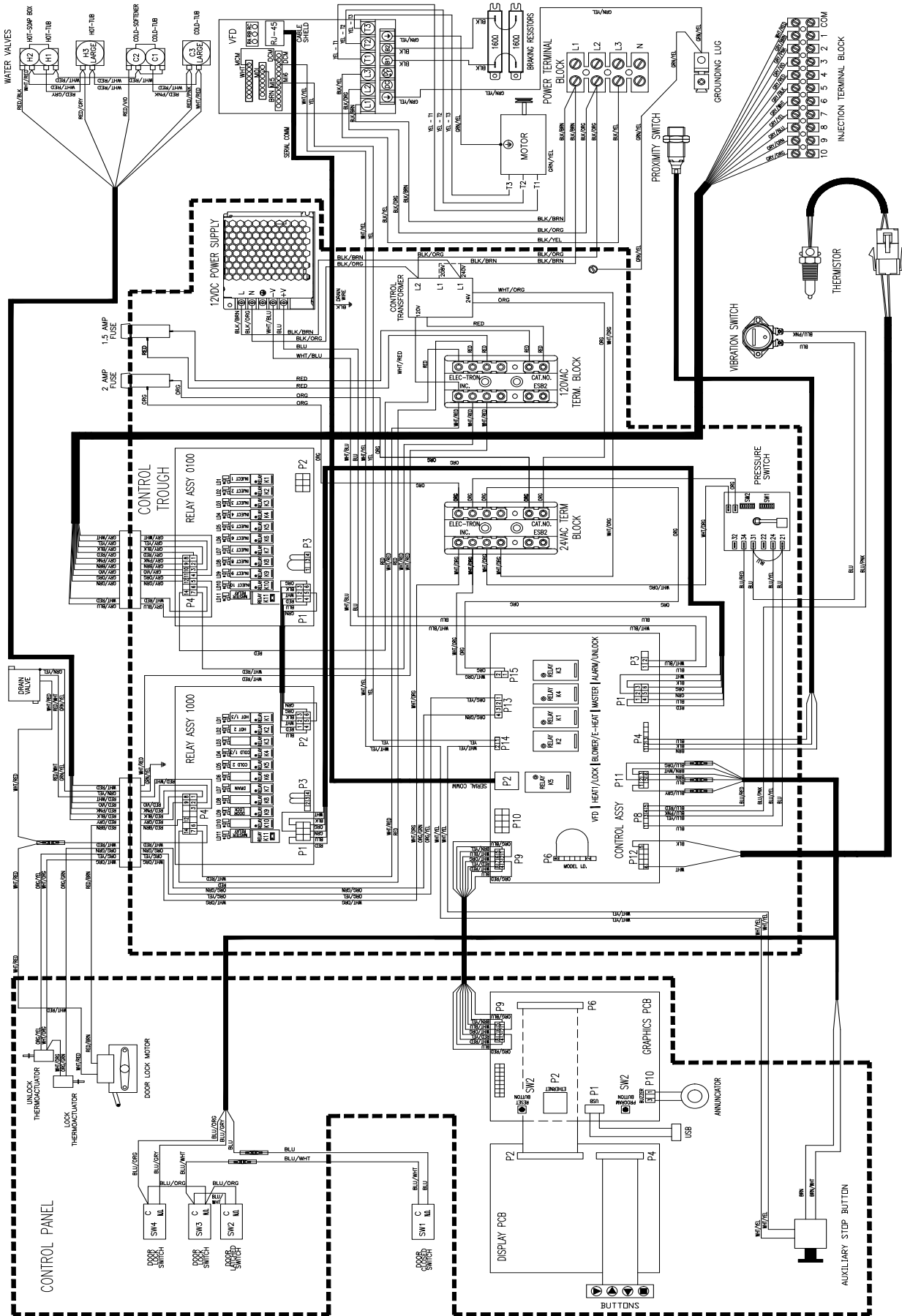

P/N 9507-060-001PR
 60 LB OPL EXPRESS PLUS, VF DRIVE
 WN0975XB-12, 02X-...-X

WIRING DIAGRAM 208 - 240V, 1/3PH, 60HZ

WN1475XB-12EO Schematic

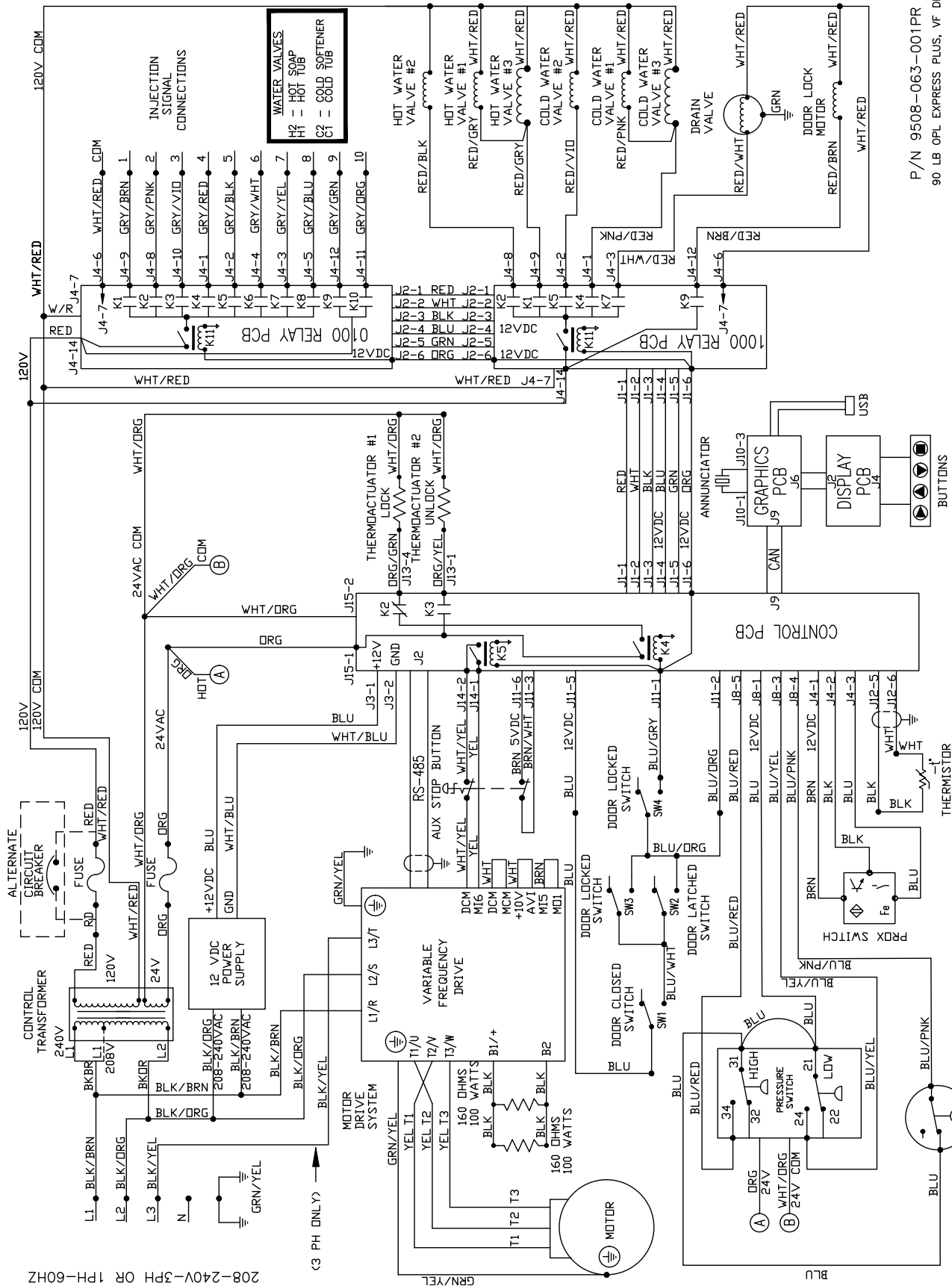

208-240V-3PH OR 1PH-60HZ

(3 PH ONLY)

P/N 9508-063-001PR
90 LB OPL EXPRESS PLUS, VF DRIVE

208-240V-1/3PH-60HZ
SCHEMATIC

WN1475XB-12EO Diagram

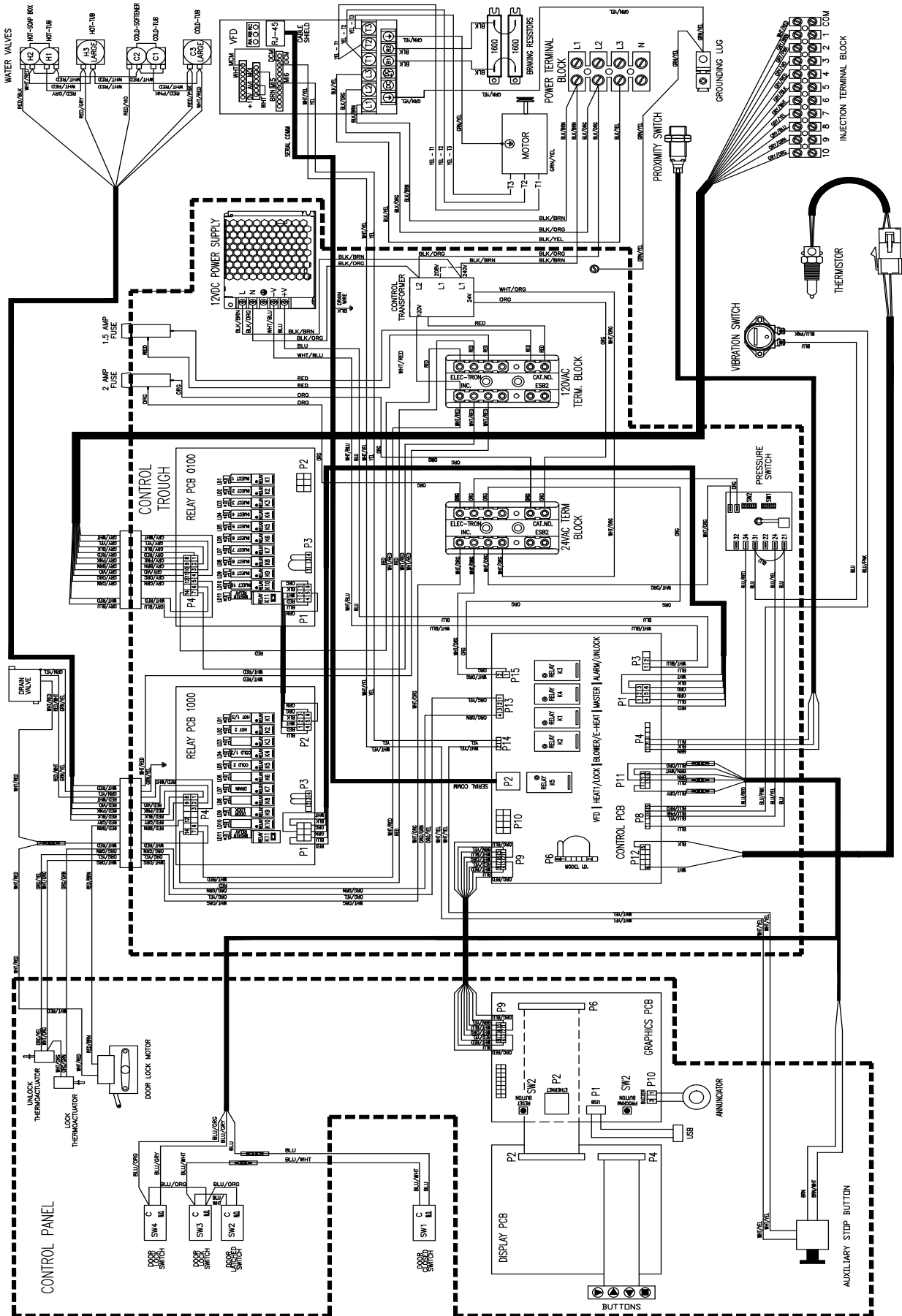

P/N 9507-063-001PR
 90 LB OPL EXPRESS PLUS, VF DRIVE
 WN1475XB-12.02X-...X

WIRING DIAGRAM 208 - 240V, 1/3PH, 60HZ



Section 8: Parts Data

WN0675XB-12EO	208-240 Volts	60 Hz	Single Phase or Three Phase
WN0975XB-12EO	208-240 Volts	60 Hz	Single Phase or Three Phase
WN1475XB-12EO	208-240 Volts	60 Hz	Single Phase or Three Phase

O-Series OPL Accessories

WN0675XA-12EO 208-240 Volts 60 Hz Single Phase or Three Phase

WN0975XA-12EO 208-240 Volts 60 Hz Single Phase or Three Phase

WN1475XA-12EO 208-240 Volts 60 Hz Single Phase or Three Phase

Key	Description	T-675	T-975	T-1475	QTY
*	Hose, Water Supply 5/8" I.D. x 48"	9990-027-013			2
*	Hose, Water Supply 5/8" I.D. x 48"		9990-027-013	9990-027-013	4
*	Rubber Washer, Inlet Hose (furnished)	8641-242-000			2
*	Strainer, Inlet Hose (furnished)	9565-003-001			2
*	Rubber Washer, Inlet Hose (furnished)		8641-242-000	8641-242-000	4
*	Strainer, Inlet Hose (furnished)		9565-003-001	9565-003-001	4
*	Bevel Washer for 3/4" bolt used in installations using angle iron bases	8641-586-003	8641-586-003	8641-586-003	4
*	Sealing compound RTV-45	8538-151-002	8538-151-002	8538-151-002	1
*	Flow Restrictors (in dispenser)	9475-002-002		9475-002-003	2
*	Clamps to hold tub front to outer tub when installing tub front	Vise Grip #11R	Vise Grip #11R	Vise Grip #11R	1
*	OPL Bearing & Seal Kit	9732-219-007	9732-219-007	9732-219-009	1
	Key Service Lock (6324)	6292-006-007	6292-006-007	6292-006-007	1
	USB Thumb Drive W/Operator Booklets all sizes	9150-045-002	9150-045-002	9150-045-002	

Wiring Harness Part # by Model

Key	Description	T-675	T-975	T-1475	
*	Cableassy-usb,snapin	9806-024-001	9806-024-001	9806-024-001	1
	Cableassy-data,rs485,40"	9806-023-004	9806-023-005	9806-023-005	1
*	Wiringharness-doorlock	9627-936-003	9627-936-001	9627-936-004	1
*	Wiringharn-pwrtermbk/VFD/ps	9627-932-001	9627-932-001	9627-932-001	1
*	Wiringharnes-15pin,injection	9627-935-001	9627-935-001	9627-935-001	1
*	Wiringharness-15pin,non-inj	9627-934-001	9627-934-001	9627-934-001	1
*	Wireasy-blu,17"	8220-063-047			1
	Wireasy-blu,23"		8220-063-049		
*	Wireasy-blu,29"			8220-063-051	1
*	Wireasy-blu/wht,17"	8220-063-048			1
	Wireasy-blu/wht,23"		8220-063-050		
	Wireasy-blu/wht,29"			8220-063-052	
*	Wireasy-jumper,blk	8220-117-002	8220-117-002	8220-117-002	2
	Wireasy-brn,#21,3"	8220-057-035	8220-057-035	8220-057-035	1
	Wireasy-wht,3"	8220-057-036	8220-057-036	8220-057-036	1
*	Wireasy-jumper,wht/red	8220-123-002			1
*	Wireasy-jumper,wht/red		8220-119-003	8220-119-003	1
*	Wireasy-red/pnk,8"		8220-108-012	8220-108-012	1
*	Wireasy-red/gry,8"		8220-108-013	8220-108-013	1
*	Wiringharn-ctrl_graph,can,wshr	9627-922-002	9627-922-002	9627-922-002	1
*	Wiringharnes-main,T-650-1450	9627-933-001	9627-933-001	9627-933-001	1
*	Wiringharness-chemical,v2.0wshr	9627-927-001	9627-927-001	9627-927-001	1
*	Wiringharness-drsw/VFD,stp	9627-928-001	9627-928-001	9627-928-003	1
*	Wiringharness-cntrl/relay,v2.0	9627-921-001	9627-921-001	9627-921-001	2
*	Wiringharness-ps,t-650-1450	9627-926-001	9627-926-001	9627-926-001	1
*	Wiringharness-pwrsup,v2.0wshr	9627-923-001	9627-923-001	9627-923-001	1
*	Wiringharness-thermist,v2.0wsh	9627-930-001	9627-930-001	9627-930-001	1
*	Wireasy,2.0	8220-158-017	8220-158-025	8220-158-029	1
*	Wireasy-jumper,v2.0,relaypcb	8220-159-005	8220-159-005	8220-159-005	1
*	Wireasy-jumper,v2.0,relaypcb	8220-159-006	8220-159-006	8220-159-006	1
*	Wireasy-org,71/2"	8220-062-052	8220-062-052	8220-062-052	1
*	Wireasy-wht/org,9"	8220-062-053	8220-062-053	8220-062-053	1
*	Wireasy-red,71/2"	8220-062-059	8220-062-059	8220-062-059	2
*	Wireasy-org,71/2"	8220-062-052	8220-062-052	8220-062-052	2

Cabinet and Front Panel Group Part # by Model

Large Door

Key	Description	T-675	T-975	T-1475	
1	Panel, Side Right - stainless	9989-644-001	9989-646-001	9989-648-001	2
1	Panel, Side Left - stainless	9989-644-002	9989-646-002	9989-648-002	4
*	Bolt-1/4-20x1/2 (side panel Front to Rear)	9545-018-013	9545-018-013	9545-018-013	8
	Nut 1/4-20UNC (side panel)	8640-414-006	8640-414-006	8640-414-006	8
	Strap Assy (Side to base)				2
	Strap Assy (Side to base)	9966-012-001	9966-012-001	9966-012-001	4
*	Shim (side panel)	9552-039-001	9552-039-001	9552-044-001	2
*	Nut, Hex 1/4-20 UNC	8640-414-006	8640-414-006	8640-414-006	8
2	Bracket, Side Panel under front panel	9046-094-001	9046-085-001	9046-086-001	1
*	Screw #10Bx1/2 side panel brkt	9545-008-026	9545-008-026	9545-008-026	1
*	Nut #10-32 UNF side panel brkt	8640-413-002	8640-414-006		1
3	Panel Assy, Front	9989-615-003	9989-617-003	9989-619-003	1
*	Trim Edge Protector	9578-092-005	9578-092-005	9578-092-005	1
4	Bumper Loading Door	9051-055-001	9051-055-001	9051-055-001	1
*	Nut, 1/4 x 20 for bumper	8640-414-003	8640-414-003	8640-414-003	1
*	Screw, #10B x 1/2	9545-008-023	9545-008-023	9545-008-023	2
*	Nut, Spring- To Control Panel 10/32	8640-442-001	8640-442-001	8640-442-001	2
5	Screw, Flat Head- Front to Sides	9545-008-014			2
5	Screw, Flat Head- Front to Sides		9545-008-014	9545-008-014	4
6	Washer, Finish	8641-585-001			2
6	Washer, Finish		8641-585-001	8641-585-001	4
*	Nut, Spring-To Front Panel	8640-442-001	8640-442-001	8640-442-001	2
*	Label, Door Opening (Black)	8502-757-001	8502-757-001	8502-757-001	1
8	Panel, Control (Mounts Nameplate)	9989-599-001	9989-600-001	9989-601-001	1
*	Screw, Control Panel to Sides	9545-008-026	9545-008-026	9545-008-026	4
9	Nameplate Decal, Control Black	9412-243-001	9412-245-001	9412-246-001	1
10	Panel Top	9989-563-007	9454-736-001		1
11A	Panel Top Front			9454-850-001	1
11B	Panel Top Rear			9454-851-001	1
12	Lock, Top (w/Key)	8650-012-003			1
12	Lock, Top (w/Key)		8650-012-003	8650-012-003	2
*	Lock Spacer	9538-189-001	9538-189-001	9538-189-001	1
13	Door, Lower Service, Includes Handle	9960-286-002	9960-286-004	9960-286-005	1
14	Handle (bumper guard)	9244-086-002	9244-086-003	9244-086-004	1
*	Rivet Blind 3/16" Alum	9491-009-003	9491-009-003	9491-009-003	4
*	Screw		9545-008-023	9545-008-023	1

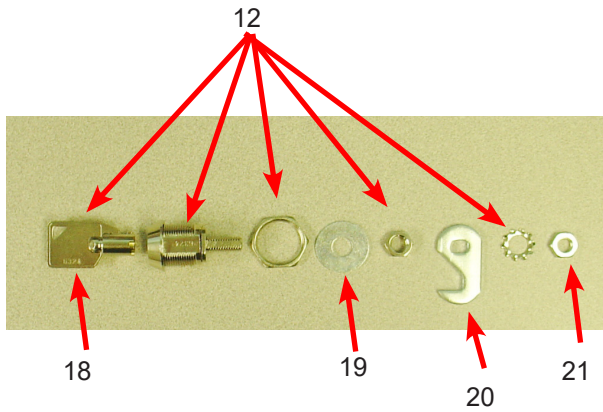
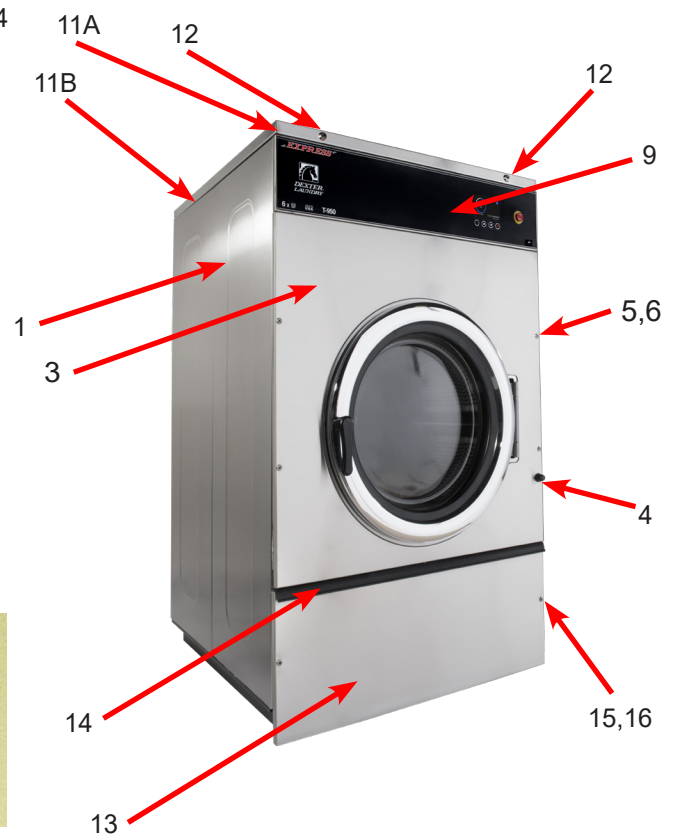
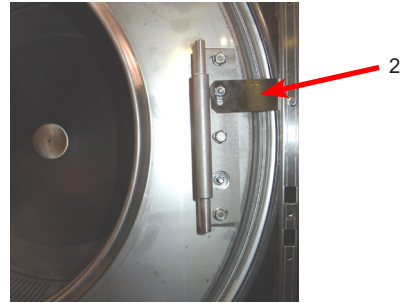
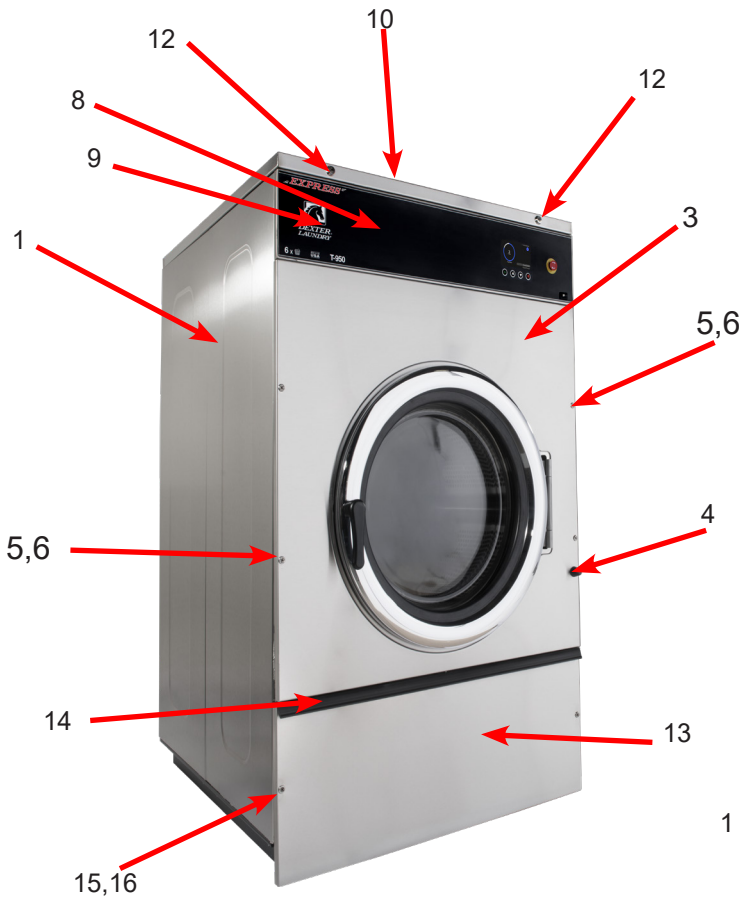

Key	Description	T-675	T-975	T-1475	
15	Screw Mtg., Flat Head 10Bx1 3/4	9545-008-014	9545-008-014	9545-008-014	2
16	Washer, Finish	8641-585-001	8641-585-001	8641-585-001	2
*	Nut, Spring	8640-399-008	8640-399-008	8640-399-008	2
18	Key, Top- # 6324	6292-006-007	6292-006-007	6292-006-007	2
19	Washer Flat 5/16	8641-581-008	8641-581-008	8641-581-008	2
20	Cam, Lock-Top	9095-049-001	9095-049-001	9095-049-001	2
21	Nut, 7mm x 1.0 Hex	8640-426-001	8640-426-001	8640-426-001	2

Cabinet and Front Panel Group Part # by Model

Front Soap Dish

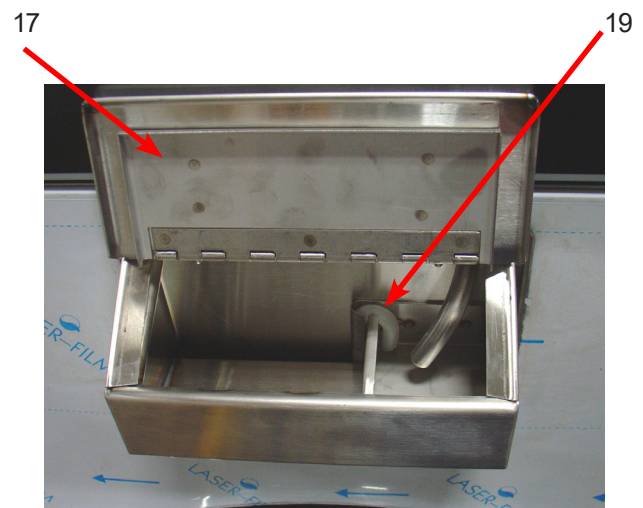
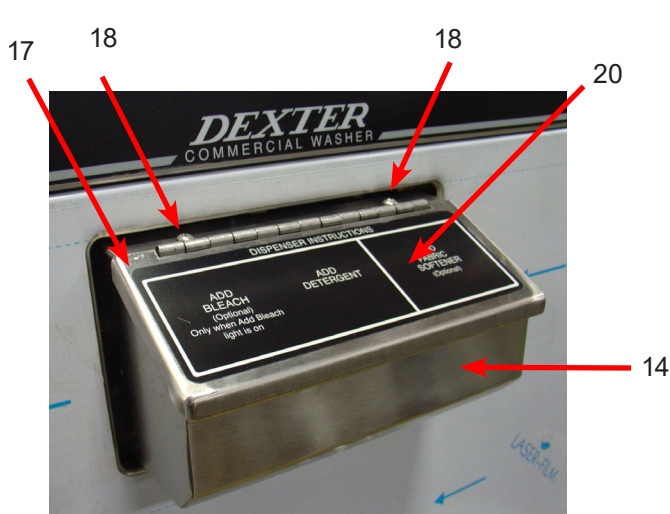
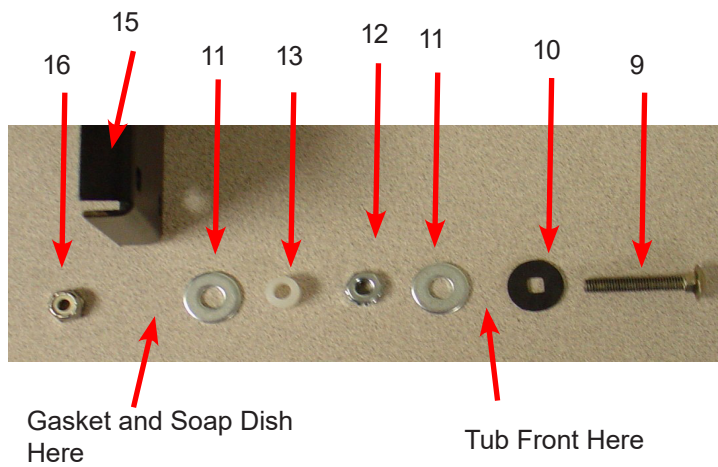
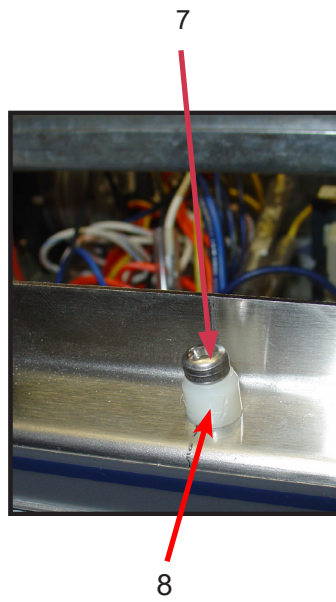
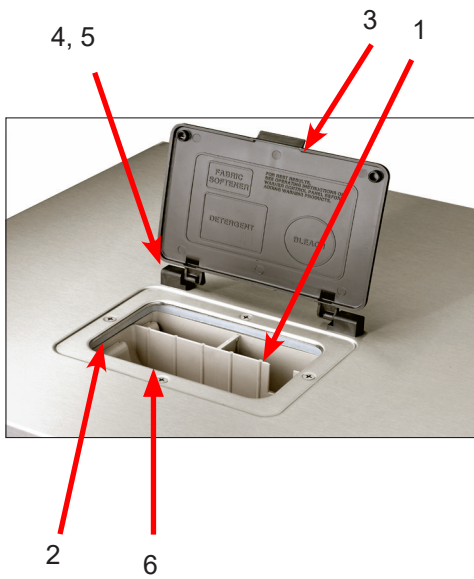

Top Mount Detergent Dispenser

Key	Description	T-675	T-975	T-1475	QTY
1	Dispenser Soap	9122-005-004	9122-005-004		1
2	Gasket Dispenser	9206-416-001	9206-416-001		1
*	Hose, Dispenser to tub	9242-450-003	9242-450-001		1
*	Clamp	8654-117-008	8654-117-008		2
*	Nut, Spring ss	8640-399-007	8640-399-007		4
*	Flow resistors	9475-002-002	9475-002-002		2
*	Flow resistors Optional (Smaller)	9475-002-003	9475-002-003		2
3	Door, Dispenser	9108-095-005	9108-095-005		1
4	Pin, Plain	9451-191-001	9451-191-001		2
*	Post, Door Mounting	9467-025-001	9467-025-001		2
6	Screw- 8B x 1/2	9545-045-002	9545-045-002		4
	Screw, SS Dispenser, 10B x 1	9545-008-012	9545-008-012		4
*	Washer Flat 5/16	8641-581-008	8641-581-008	8641-581-008	1
8	Plastic Sleeve, Locator	9355-001-001	9355-001-001	9355-001-001	2
*	Catch, Top Panel	9086-017-001			2
	Lock, Top (w/Key)	8650-012-003			1
*	Lock, Top (w/Key)		8650-012-003	8650-012-003	2
	Channel-support,dispenser	9081-108-001	9081-108-001		1
	Screw-hxwshrhdundct,#10bx1/2	9545-008-026	9545-008-026		1
	Screw-hxwshdsl,10bx1/4	9545-008-001	9545-008-001		2

Front Mount Detergent Dispenser

Key	Description	T-675	T-975	T-1475	QTY
9	Bolt,#10-32 x 1 1/4"SS			9545-012-026	6
10	Special Washer, Rubber			8641-222-000	6
*	Tub Front			9974-012-001	1
11	Washer-Flat, 1/4			8641-581-018	12
12	Nut, #10-32UNF			8640-413-002	6
13	Spacer Plastic #10x1/2				6
14	Soap Dispenser (no lid)			9807-087-001	1
*	Det. Dispenser Mtg Gasket to Tub frnt			9206-425-001	1
15	Bracket Soap box mounting			9029-122-002	1
16	Nut Hex Elasticstop #10-32 SS mtg dispenser			8640-413-006	6
17	Lid Assembly dispenser			9987-104-001	1
18	Lid screws #10-32x1/2 SS			9545-012-017	2
19	Softener siphon tube (plastic)			9574-252-002	1
*	Flow resistors			9475-002-003	AR
20	Washer Dispenser Label Black			8502-745-001	1
*	Kit to Remove Front Soap Dish			9732-353-004	1

Chemical Injection Only No Front Mount Detergent Dispenser

Key	Description	T-675	T-975	T-1475	QTY
*	Front Panel			9989-683-009	1
*	SS Bracket, Cover Plate			9029-122-003	1
*	Kit to Add Front Soap Dish			9732-353-002	1

Rear View Access Part # by Model

Key	Description	T-675	T-975	T-1475	
1	Drive Motor, 3 Phase (Inverter duty)	9376-319-001	9376-329-001	9376-328-001	1
2	Rod, Motor Mtg	9497-222-004	9497-222-004	9497-222-004	1
*	Collar, Shaft (w/set screws)			9076-052-002	2
3	New motor bushing support	9053-082-001	9053-082-001	9053-082-001	2
4	Clamp for motor bushing	8654-117-019	8654-117-019	8654-117-019	2
5	Pulley, Motor	9453-170-003	9453-175-002	9453-175-002	1
*	Set Screw 5/16 18-7/8	9545-028-015			
*	Split TaperBushing (motor pulley)		9053-077-001	9053-077-001	2
*	Screw taper bushing 1/4-20x1		9545-018-024	9545-018-024	3
6	Bolt, Eye (1/4"-20x1/2")	9545-055-001	9545-055-001	9545-055-001	1
*	Nut, 1/4 Elastic Stop	8640-414-003	8640-414-003	8640-414-003	1
*	Link (open end)		9341-046-001		1
7	Chain (Spring Tension)		9099-012-003		1
8	Spring, Belt Tension	9534-151-000	9534-151-000	9534-151-000	1
*	Bracket Belt Tension	9029-206-001		9029-206-002	1
*	Lock Washer, Exttooth, 5/16			8641-582-009	
9	Pulley, Driven	9453-173-002	9453-176-006	9453-176-006	1
*	Tolerance Ring	9487-234-004			1
*	Screw, 5/8"-11 x 2"	9545-060-004			1
*	Washer-Flat, 5/8"	8641-582-032			1
*	Lockwasher, 5/8"	8641-581-018			1
10	Bolt, 3/8"-16 x 2"		9545-029-011	9545-029-011	3
11	Washer, 3/8"		8641-582-003	8641-582-003	3
*	Bushing Taperlock (Driven)		9053-078-002	9053-078-002	1
12	Washer-Flat .675x2-1/2x1/4		8641-581-043		1
13	Lockwasher-Exttooth, 5/8	8641-582-018	8641-582-018		1
14	Bolt, 5/8-11x1 1/2		9545-060-001		1
12	Washer-Flat, .781x2-1/2x1/4			8641-581-044	1
13	Lockwasher-Exttooth, 3/4			8641-582-020	1
14	Bolt, 3/4-10-1 1/2			9545-057-004	1
15	Drive Belt		9040-079-002	9040-079-006	1
15	Drive Belt	9040-076-005			2
*	Panel Assy., Back	9989-567-001	9989-526-001		1
*	Panel Assy., Back, Lower			9454-872-001	1
*	Panel Assy., Back, Upper			9454-873-001	1
*	Screw Panel Mtg.#10Bx1/2"	9545-008-026	9545-008-026	9545-008-026	AR
*	Nut, Spring	8640-399-008	8640-399-008	8640-399-008	AR
*	Screw, To Base-1/4" x 3/4"	9545-030-002	9545-030-002	9545-030-002	AR
16	Injection- tube assy	9883-005-001	9883-012-001	9883-011-001	1
*	Hose, Injection Tube to Tub	9242-461-001	9242-461-001	9242-461-001	1
*	Clamp, Injection Hose	8654-117-014	8654-117-014	8654-117-014	2
*	Cap-injectorassembley	0935-127-001	0935-127-001	0935-127-001	1
*	Hose-injectionasy,2" diameter	9242-462-001			1
*	Clamp-hose	8654-117-008			1
*	Clamp-hose,ssworm	8654-117-009			1

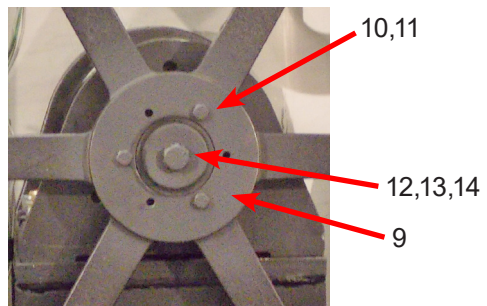
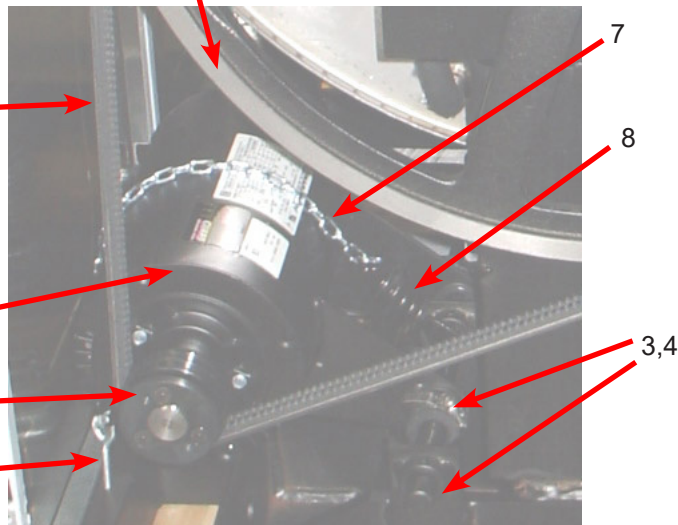
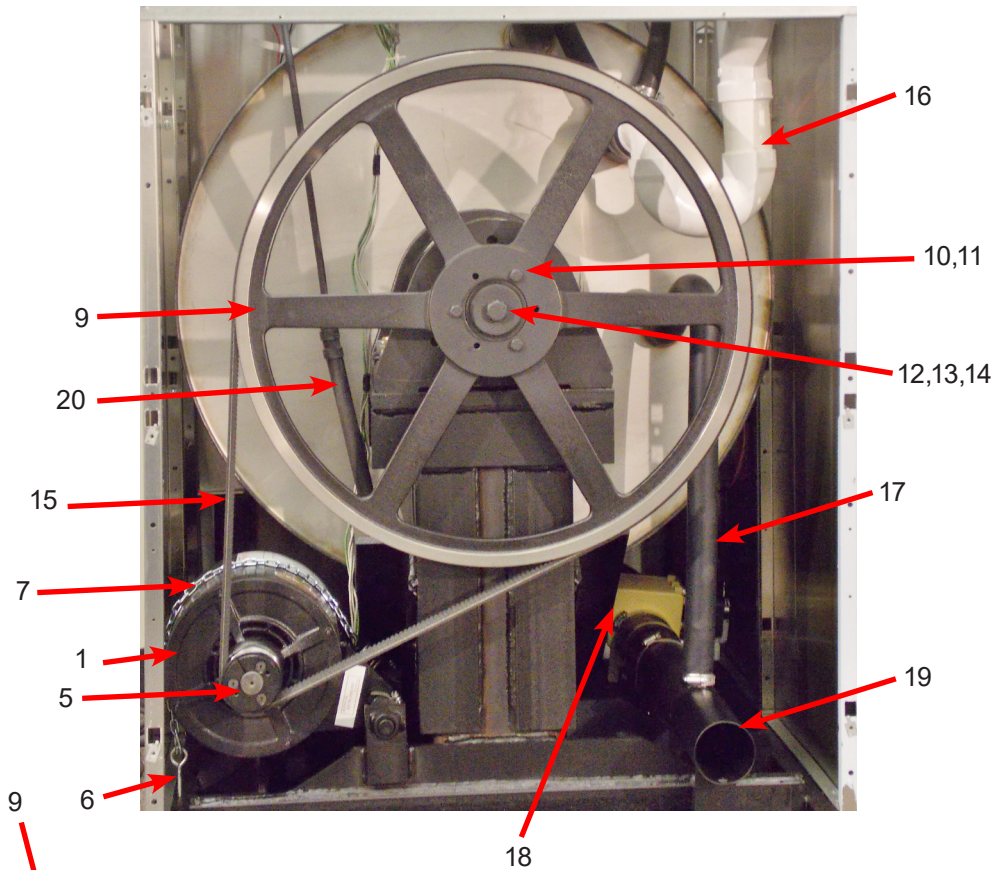

Key	Description	T-675	T-975	T-1475	
17	Hose-Overflow	9242-449-002	9242-449-003	9242-449-005	1
*	Clamp Hose Over Flow	8654-117-018	8654-117-018	8654-117-018	2
18	Drain Valve	9379-202-001	9379-202-001	9379-202-001	1
*	Hose, Drain Valve to Tube	9242-464-001	9242-459-001	9242-459-001	1
*	Clamp	8654-117-014	8654-117-014	8654-117-014	2
	Hose-drainvalve,outlet	9242-457-001	9242-457-001	9242-457-002	1
19	Drain Tube	9915-124-002	9915-120-004	9915-129-002	1
20	Hose-Pressure Switch	9242-175-002	9242-175-007	9242-175-004	1
*	Clamp Pressure switch Tube	8654-117-015	8654-117-015	8654-117-015	1
*	Anchor-wiretie,adhesive	9004-007-001	9004-007-001	9004-007-001	1

Rear Channel Parts Group

	Description	T-675	T-975	T-1475	
1	Channel Assembly Rear	9947-032-001	9947-028-001	9947-029-001	1
2	Screw #10Bx1/2	9545-008-026	9545-008-026	9545-008-026	4
*	Nut, Spring			8640-399-008	4
3	Plug, 7/8"	9456-041-006	9456-041-006	9456-041-006	2
4	Bushing, 7/8"	9053-067-002	9053-067-002	9053-067-002	1
5	Bracket-Terminal Block Assy	9029-265-001	9029-265-001	9029-265-001	1
6	Screw, 10Bx1/2	9545-008-026	9545-008-026	9545-008-026	4
7	Strip-Terminal marker, Power	9558-025-001	9558-025-001	9558-025-001	1
8	Terminal Block-Power	9897-033-002	9897-033-002	9897-033-002	1
*	Screw-6ABx3/4	9545-031-010	9545-031-010	9545-031-010	2
9	Harness-Power Terminal Block	9627-932-001	9627-932-001	9627-932-001	1
10	Terminal Lug, Solderless	8652-134-001	8652-134-001	8652-134-001	1
*	Lockwasher-Exttooth, #10	8641-582-006	8641-582-006	8641-582-006	1
*	Screw-10-32ttX1x1/2Grn	9545-008-027	9545-008-027	9545-008-027	1
11	Strip-Terminal Marking, Injector	9558-036-001	9558-036-001	9558-036-001	1
12	Terminal Block-Injector	9897-032-003	9897-032-003	9897-032-003	1
*	Screw-4Bx5/8ss	9545-053-002	9545-053-002	9545-053-002	2
13	Harness-Injection	9627-935-001	9627-935-001	9627-935-001	1
14	Label-Warning	8502-639-001	8502-639-001	8502-639-001	1
15	Bushing-Insulated, 3/4"	9053-067-001			1
16	Bushing-Insulated, 1"	9053-067-004	9053-067-004	9053-067-004	1
*	Cover, Terminal Block	9074-267-001	9074-267-001	9074-267-001	1
*	Screw #10Bx1/2	9545-008-026	9545-008-026	9545-008-026	1
17	Plate-Drive mounting	9982-383-001	9982-383-001	9982-384-001	1
18	Nut, #10-32UNF, 2B	8460-413-002	8460-413-002	8460-413-002	4
19	VFD Delta "E" drive 208-240 volt	9375-030-018	9375-028-026	9375-029-010	1
*	VFD Cooling Fan	9189-013-001	9189-013-001	9189-014-001	1
*	Key Pad-Display Delta "E" Drive (P/S) only	9150-044-001	9150-044-001	9150-044-001	1
*	VFD, MS300, O2	9375-035-017	9375-036-024	9375-037-006	1
*	VFD Cooling Fan	9189-016-001	9189-016-001	9189-017-001	1
20	Nut, #10-32UNF, 2B	8460-413-002	8460-413-002	8460-413-002	4
*	Cable, Data	9806-023-004	9806-023-005	9806-023-005	1
*	Clamp, Cable	8654-125-005	8654-125-005	8654-125-005	1
21	Plate-Water Valves, Mounting	9452-813-001	9452-814-001	9452-814-001	1
22	Nut, #10-32UNF, 2B	8460-413-002	8460-413-002	8460-413-002	4
23	Valve-Water, Duel Coil	9379-183-012	9379-183-012	9379-183-012	2
24	Screw #10Bx1/2	9545-008-026	9545-008-026	9545-008-026	4
25	Water-Valve, Single Coil		9379-194-001	9379-194-001	2
26	Screw-Phillips, 4mx0.7x8mm		9545-064-001	9545-064-001	4
27	Shield, Water Valves	9550-194-001	9550-195-001	9550-195-001	1
28	Clip-Push	9083-121-001			3
28	Clip-Push		9083-121-001	9083-121-001	4
29	Cap-Injector Assy	0935-127-001	0935-127-001	0935-127-001	1
30	Clamp	8654-117-014	8654-117-014	8654-117-014	1
31	Hose-Suds Overflow	9242-463-004	9242-463-004	9242-463-006	1
32	Resistors (160 Ohm)		9483-004-003	9483-004-003	2
*	Resistors (200 Ohm)	9483-004-002			2
33	Screws #10-32x1/2" (Mounting)	9545-008-026	9545-008-026	9545-008-026	4
34	Jumper Wires	8220-117-002	8220-117-002	8220-117-002	2

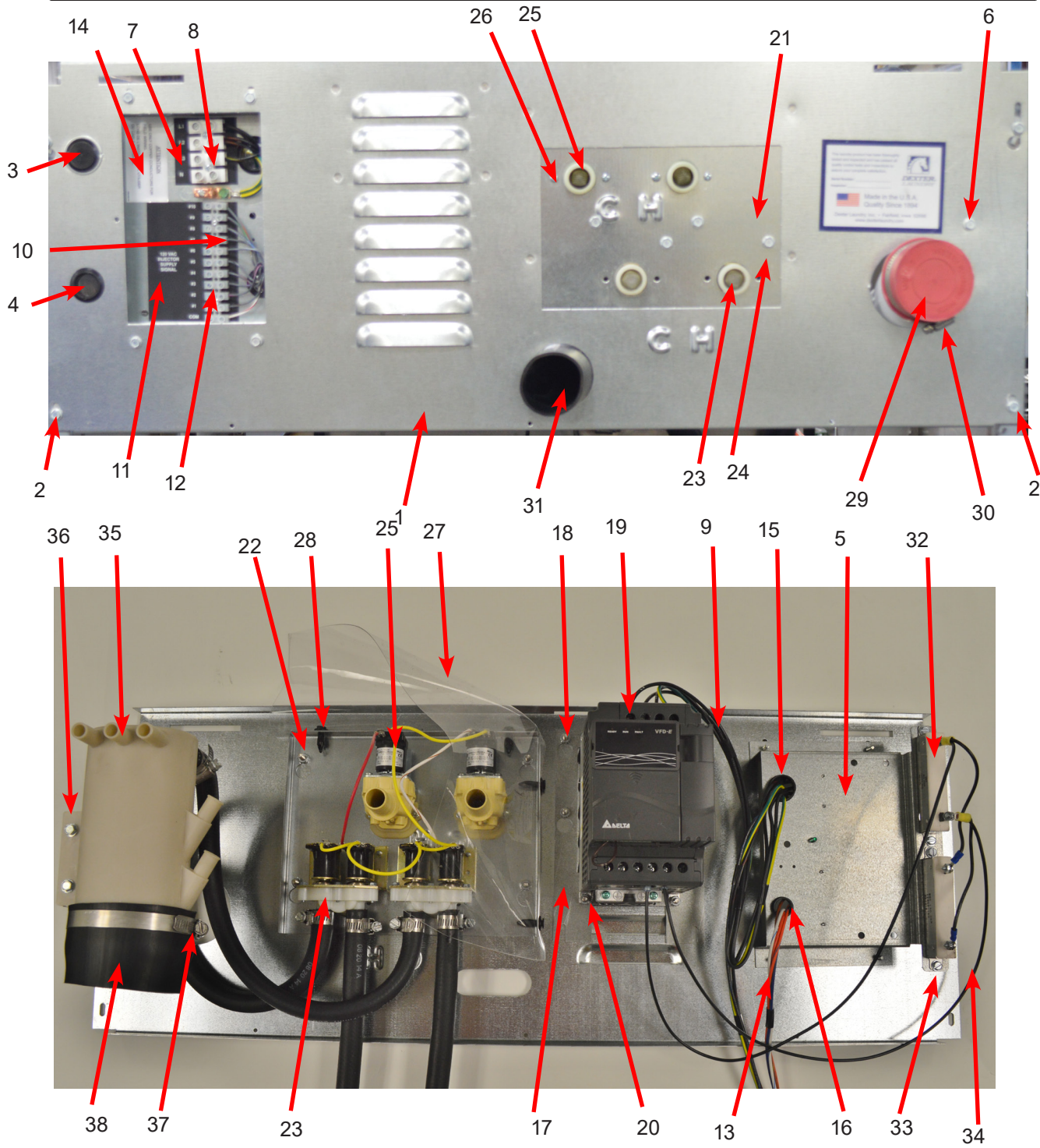

Key	Description	T-675	T-975	T-1475	
35	Vacuum Breaker	9610-001-001	9610-001-001	9610-001-001	1
*	Bracket-Vacuum Breaker	9029-077-001	9029-077-001	9029-266-001	1
*	Vacuum Breaker Cap	0935-135-002	0935-135-002	0935-135-002	*
36	Screw, 10Bx1/2	9545-008-026	9545-008-026	9545-008-026	4
37	Clamp, Vacuum Breaker End	8654-117-014	8654-117-014	8654-117-014	1
38	Hose, Vacuum Breaker to Tub Injection Tube	9242-461-001	9242-461-001	9242-461-001	1

Cylinder, Seals & Bearings Part # by Model

Key	Description	T-675	T-975	T-1475	
*	Bearings and Seal Kit	9732-219-007	9732-219-007	9732-219-009	1
1	Housing, Bearing- Assembly (items #2-#6)	9803-187-001	9803-187-001	9803-209-001	1
2	Housing, Bearing	9241-181-004	9241-181-004	9241-195-003	1
3	Bearing, Front (LARGE)	9036-159-005	9036-159-005	9036-162-002	1
4	Bearing, Rear (SMALL)	9036-159-006	9036-159-006	9036-162-001	1
5	Spacer, Bearing	9538-170-001	9538-170-001	9538-185-001	1
6	Ring, Bearing Retainer	9487-238-004	9487-238-004	9487-238-004	1
7	Tub Assembly	9930-169-001	9930-184-003	9930-155-001	1
8	Seal, Small V85A	9532-140-007	9532-140-007		1
8	Seal, Small V95A			9532-140-012	1
9	Seal, Large V140A	9532-140-008	9532-140-008	9532-140-008	1
10	Ring, Seal Mounting	9950-052-001	9950-052-001	9950-062-001	1
11	Tub Back Ring Seal	9487-266-001	9487-266-001	9487-276-001	1
	Mating Ring Seal	9487-261-004	9487-261-004	9487-261-005	1
12	Bolt, Tub End of Bearing Housing (7/16-14x1), Bolt from inside Tub	9545-059-004	9545-059-004	9545-059-004	6
13	Washer, Flat	8641-581-034	8641-581-034	8641-581-034	6
14	Screw-Hex Cap, 3/4"-10 x 3" (Bearing Housing to Frame)	9545-057-002	9545-057-002		6
14	Screw-Hex Cap, 7/8"-10 x 3" (Bearing Housing to Frame)			9545-066-001	6
15	Washers Spherical 3/4 (Male half) (Bearing Housing to Frame)	8641-588-001	8641-588-001		6
15	Washers Spherical 7/8 (Male half) (Bearing Housing to Frame)			8641-588-003	6
16	Washers Spherical 3/4 (Female half) (Bearing Housing to Frame)	8641-588-002	8641-588-002		6
16	Washers Spherical 7/8 (Female half) (Bearing Housing to Frame)			8641-588-004	6
17	Nut 3/4"-10 (Bearing Housing to Frame)	8640-418-003	8640-418-003		6
17	Nut 7/8"-9 (Bearing Housing to Frame)			8640-437-001	6
18	Pulley, Driven	9453-173-002	9453-176-006	9453-176-006	1
*	Tolerance Ring	9487-234-004			1
*	Screw, 5/8"-11 x 2"	9545-060-004			1
*	Washer-Flat, 5/8"	8641-581-032			1
*	Washer-Flat, 5/8"	8641-582-018			1
19	Bolt, 3/8"-16 x 2"		9545-029-011	9545-029-011	3
20	Washer, 3/8"		8641-582-003	8641-582-003	3
21	Bushing Taperlock (Driven & Large)		9053-078-002	9053-078-002	1
22	Washer-Flat .675x2-1/2x1/4		8641-581-043		1
23	Lockwasher-Exttooth, 5/8		8641-582-018		1
24	Bolt, 5/8-11x1 1/2		9545-060-001		1
22	Washer-Flat, .781x2-1/2x1/4			8641-581-044	1
23	Lockwasher-Exttooth, 3/4			8641-582-020	1
24	Bolt, 3/4-10-1 1/2			9545-057-004	1
25	Tub & Cylinder Assy	9869-035-004	9869-027-006	9869-026-001	1

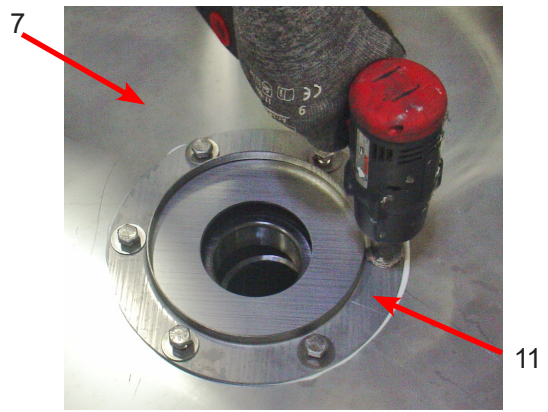
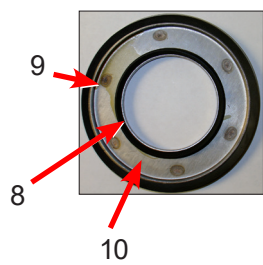
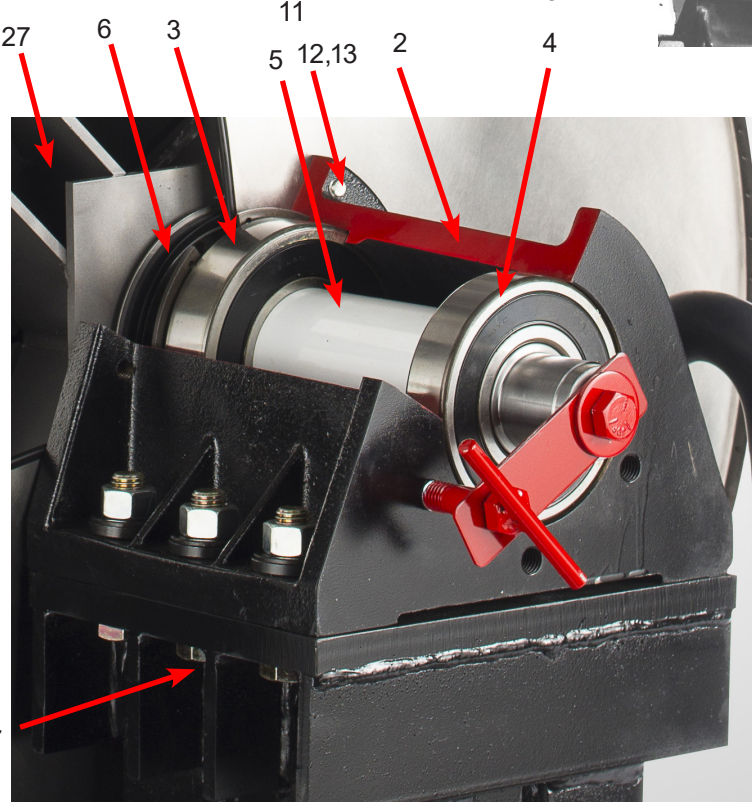
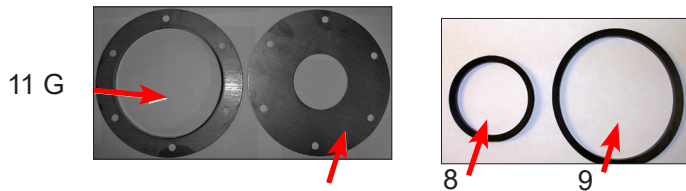
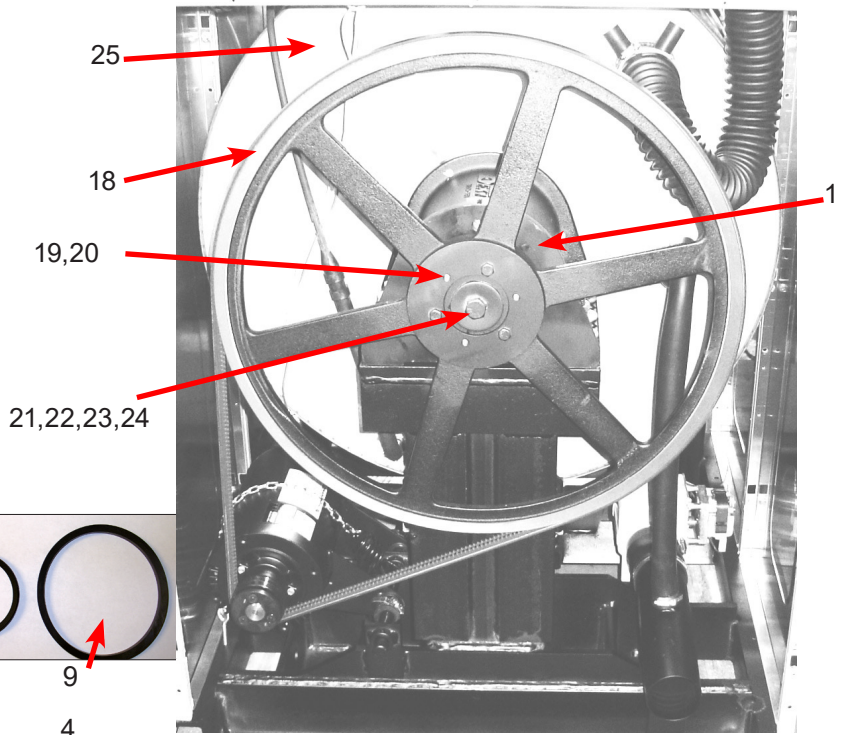
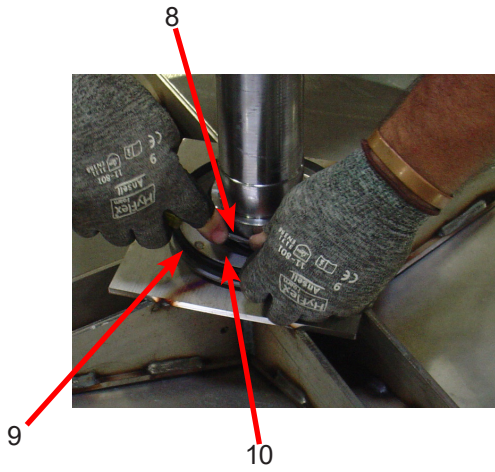

Key	Description	T-675	T-975	T-1475	
27	Cylinder Assy	9848-145-001	9848-172-001	9848-141-001	1
*	Tub Front	9974-014-002	9974-019-002	9974-012-001	1
*	Gasket, Tub Front	9206-421-004	9206-421-002	9206-421-003	1
*	Ring Assy, Tub Mtg-Front Clamp	9950-063-001	9950-055-001	9950-061-001	1
*	Bolt, Top Front Ring 3/8"-16 x 3"	9545-029-009	9545-029-009	9545-029-009	1
*	Nut 3/8"-16	8640-415-001	8640-415-001	8640-415-001	1

Door Lock Assembly (All Models)

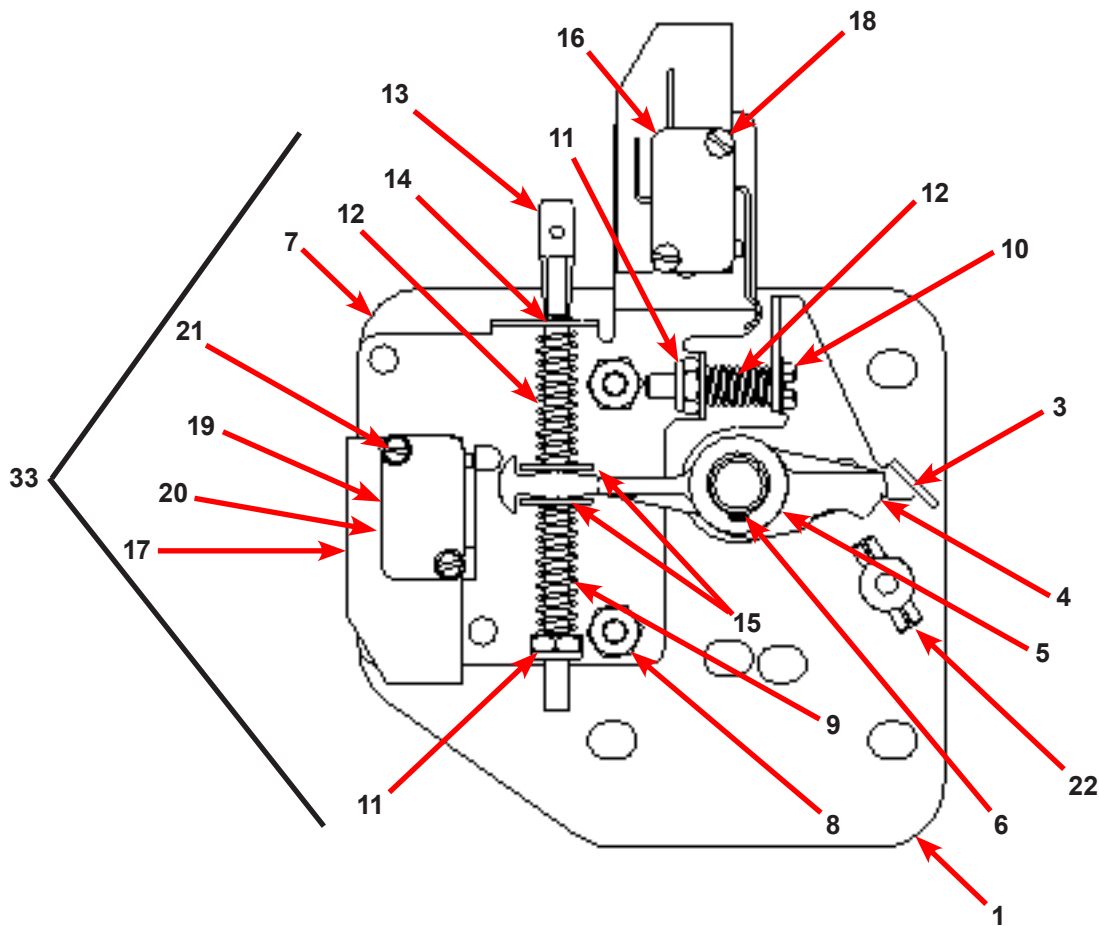

Key	Description	All Models	QTY
33	Lock Assy, Complete (#1-22) (includes #1 thru #22)	9885-031-001	1
1	Plate Assy, Door Lock	9982-346-001	1
2	Washer, Flat (SS or Brass)	8641-581-030	1
3	Actuator, Latching Switch	9008-005-001	1
4	Pawl, Locking	9450-003-002	1
5	Washer, Spring	8641-569-003	1
6	Ring, Retaining	9487-200-004	1
7	Bracket Switch	9029-163-001	1
8	Nut, Hex 10-32 UNF	8640-413-002	2
9	Spring, Actuating	9534-364-002	1
10	Screw, Hx. 10-32 x 1"	9545-012-020	1
11	Nut, Elastic Stop 10-32	8640-413-004	2
12	Spring, Return	9534-364-001	2
13	Pin, Guide	9451-193-001	1

Key	Description	All Models	QTY
14	Ring, Retaining	9487-200-005	1
15	Washer	8641-581-031	1
16	Switch, Latching Sensing	9539-461-008	1
17	Shield, Switch	9550-169-003	3
18	Screw 4-40 x 5/8"	9545-020-001	2
18	Nut, Twin 4-40	8640-401-001	1
19	Switch, Locking Sensing	9539-461-007	2
20	Actuator, Switch Locking	9008-006-003	1
21	Screw 4-40 x 1 1/8"	9545-020-003	2
21	Nut, Twin 4-40	8640-401-001	1
*	Spacer Sensor	9538-182-001	*
22	Pin, Dowel (for door cam)	9451-181-004	1
*	Shim, Door Lock, Thin	9552-037-001	AR
*	Screw, Lock mtg 1/4"-20 x 3/4"	9545-018-014	3
*	Lockwasher 1/4" Ext tooth	8641-582-007	3
*	Door Stud Pin, 3/16" x 3/4"	9451-181-004	1

Gear Motor Door Lock Assembly

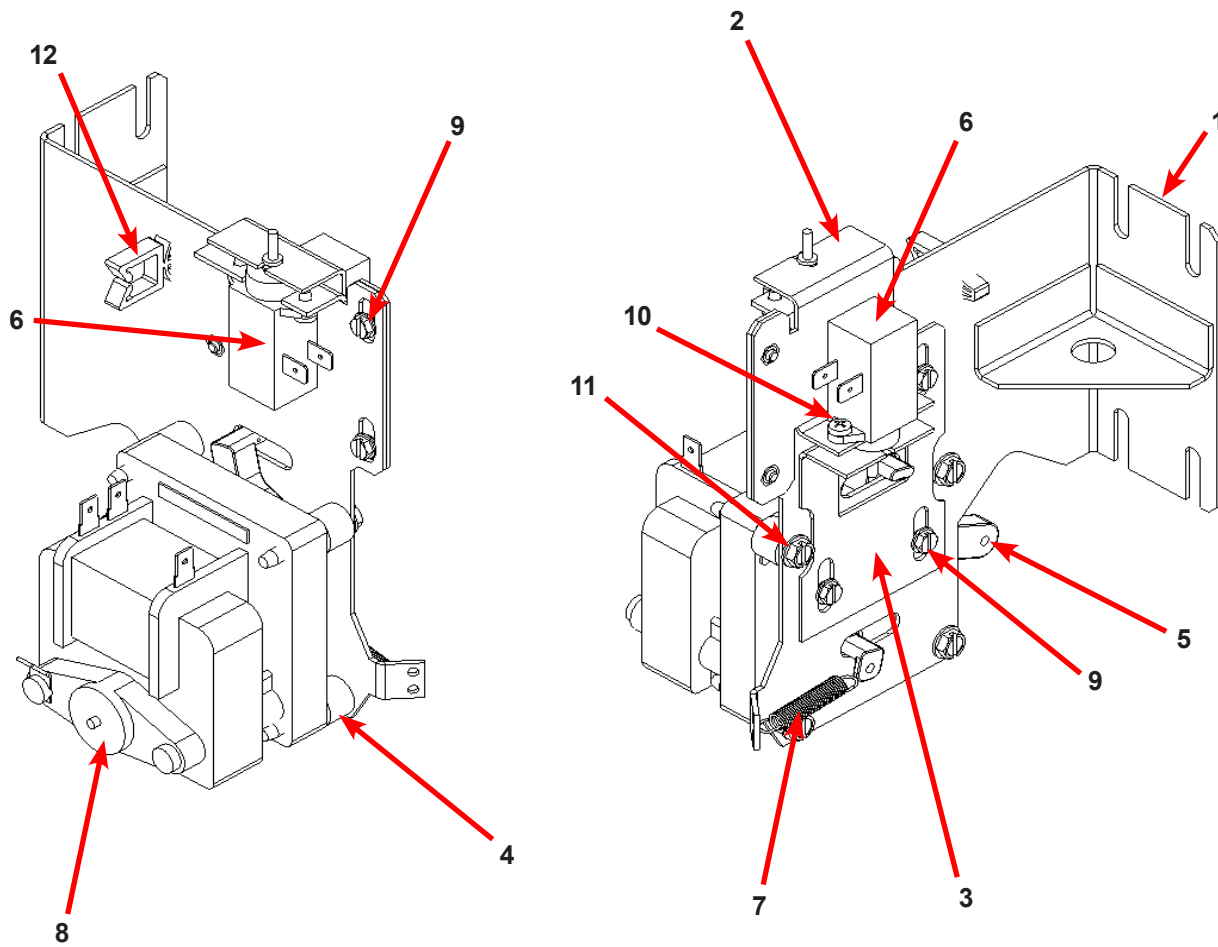

Key	Description	T-675	T-975	T-1475	QTY
*	Actuator Assembly (Includes 1-10, Rod NOT included)	9892-015-003	9892-015-003	9892-015-003	1
11	Screw - hwxshdsl, 10-24 - 1.25f, ctd	9545-046-007	9545-046-007	9545-046-007	4
10	Cross Recessed Pan Hd Tapping screw	9545-031-011	9545-031-011	9545-031-011	4
9	Screw -Hxwshrhdslems, 6-32 x 3/16	9545-044-003	9545-044-003	9545-044-003	6
8	Motor & Gear Assembly 120v	9914-137-015	9914-137-015	9914-137-015	1
7	Spring - Extension	9534-350-001	9534-350-001	9534-350-001	1
6	Thermoactuator - Door Lock Relay 24v	9586-001-003	9586-001-003	9586-001-003	2
5	Arm - Door Lock	9001-063-001	9001-063-001	9001-063-001	1
4	Spacer, Plastic	9538-157-021	9538-157-021	9538-157-021	4
3	Bracket Slide Lock	9029-204-001	9029-204-001	9029-204-001	1
2	Bracket Assy, Slide - Unlock	9985-189-001	9985-189-001	9985-189-001	1
1	Bracket Assy, Slide - Unlock	9985-190-001	9985-190-001	9985-190-001	1
*	Rod, Door Lock	9497-225-017	9497-225-015	9497-225-016	1

Large Door & Hinge Group

Key	Description	T-675	T-975	T-1475	QTY
1	Door Hinge Assembly (mounts to tub front)	9955-030-001	9955-031-001	9955-031-001	1
*	Door Assembly Complete	9960-309-001	9960-310-001	9960-310-001	1
2	Door Ring 180 degree large hinge	9487-265-002	9487-275-001	9487-275-001	1
3	Door Gasket	9206-419-001	9206-431-001	9206-431-001	1
4	Door Glass Window	9635-016-001	9635-020-001	9635-020-001	1
*	Wireasy-blu (Door Close Switch)	8220-063-047	8220-063-049	8220-063-051	1
	Wireasy-blu/wht (Door Close Switch)	8220-063-048	8220-063-050	8220-063-052	1
5	Switch, Door Hinge Close (Plunger)	9539-492-001	9539-492-001	9539-492-001	1
6	Top Door Hinge Leaf (No pin)	9845-008-001	9845-006-001	9845-006-001	1
7	Bottom Door Hinge Leaf	9845-005-002	9845-007-001	9845-007-001	1
8	Thrd Form Screw, Door Mtg 5/16" x 5/8"	9545-056-002			3
8	Thrd Form Screw, Door Mtg 5/16" x 5/8"		9545-056-002	9545-056-002	4
9	Screw, Loading Door Hinge Mtg - 5/16-18 x 3/4	9545-014-009	9545-014-013	9545-014-013	3
*	Shim Large door	9552-043-001	9552-043-001	9552-043-001	1
*	Shim-loaddoorhinge(thin)	9552-036-001			1

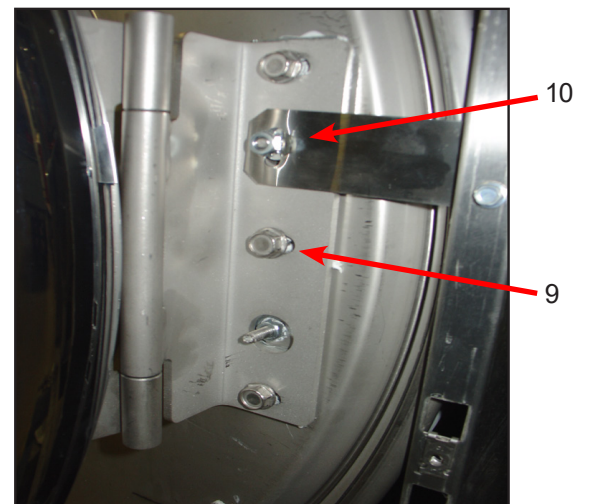

Key	Description	T-675	T-975	T-1475	
*	Shaft Assembly (includes 11-13)	9913-136-001	9913-136-001	9913-136-001	
11	Shaft, Door Locking	9537-195-002	9537-195-002	9537-195-002	1
12	Cam, Locking	9095-051-001	9095-051-001	9095-051-001	1
13	Pin, Groove (1 1/4)	9451-181-005	9451-181-005	9451-181-005	1
14	Pin, Groove (3/4)	9451-181-004	9451-181-004	9451-181-004	1
15	Spring, Lock Cam	9534-360-002	9534-360-002	9534-360-002	1
16	Handle, Door	9244-091-001	9244-091-001	9244-091-001	1
17	Pin, Door Handle (groove)	9451-181-005	9451-181-005	9451-181-005	1

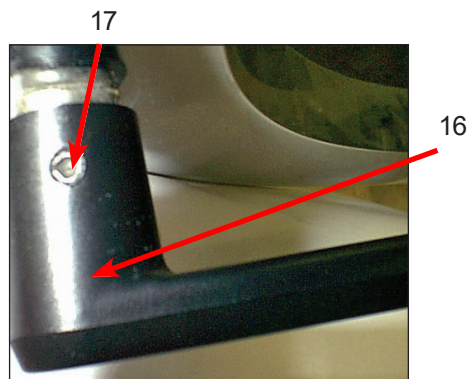
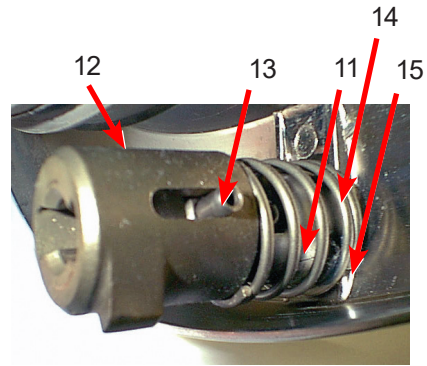
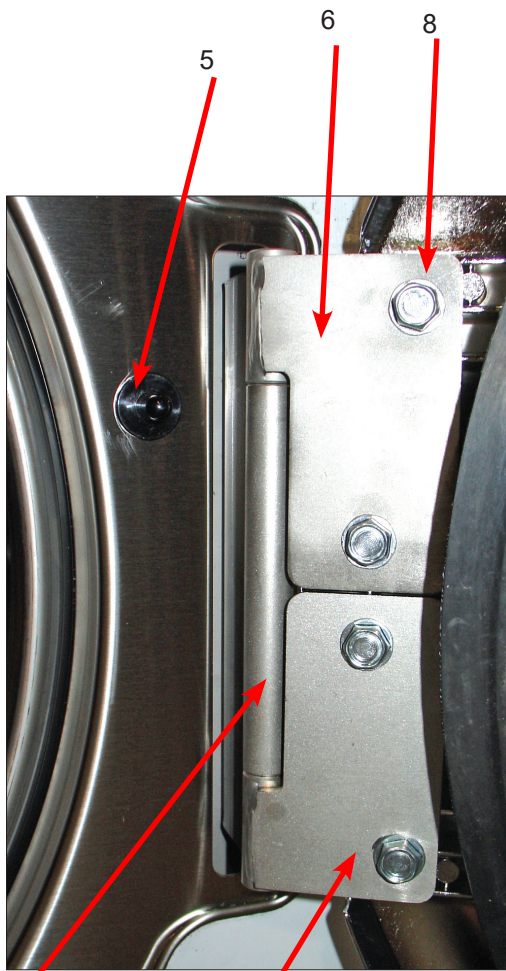

1

7

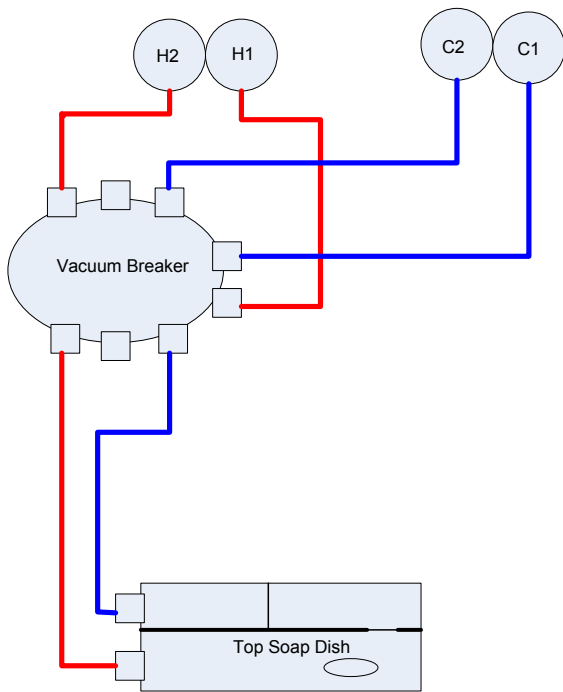
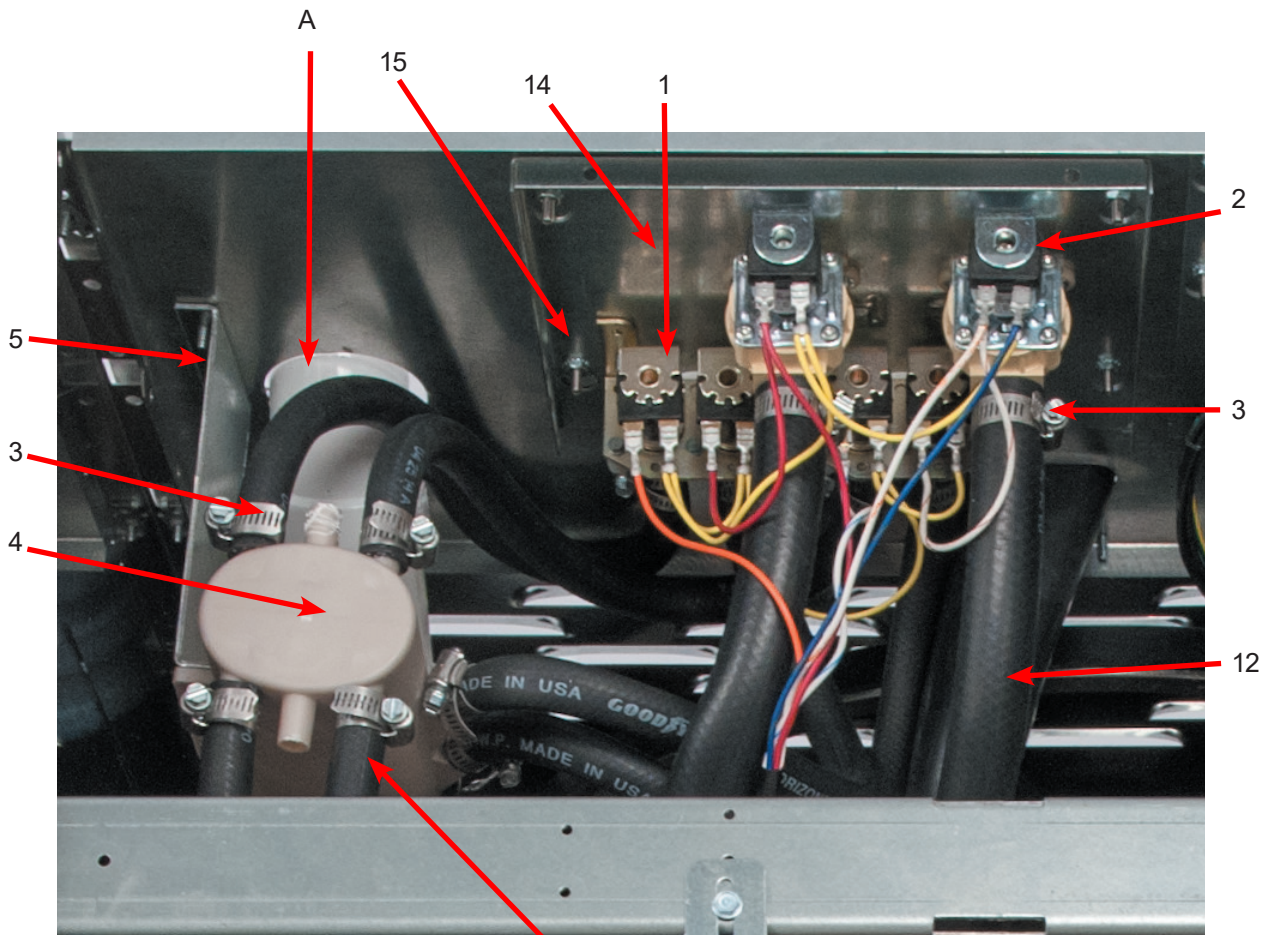

Top Soap Box Design

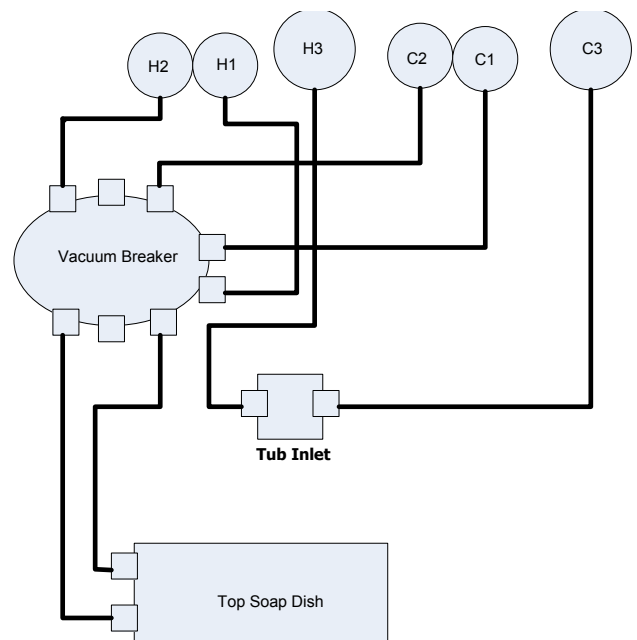

Top Soap Box 4 Valve Design

Water Inlet Part # by Model

Key	Description	T-675	T-975	T-1475	
A	Injector Assembly	9883-005-001	9883-012-001	9885-011-001	1
1	Valve, Water Inlet (dual outlet) (see Water Inlet Valve Break-down for individual parts)	9379-183-012	9379-183-012	9379-183-012	2
*	Screw, Valve Mtg	9545-008-026	9545-008-026	9545-008-026	4
2	Valve Water Inlet (single outlet)		9379-194-001	9379-194-001	4
*	Screw, Valve M4x0.7x8mm		9495-064-001	9545-064-001	8
3	Clamp-Water Valves	8654-117-015	8654-117-008	8654-117-008	AR
*	Shield over Water Valves Plastic	9550-194-001	9550-195-001	9550-195-001	1
*	Clip-Push	9083-121-001			3
*	Clip-Push		9083-121-001	9083-121-001	4
4	Vacuum Breaker	9610-001-001	9610-001-001	9610-001-001	1
5	Bracket, Vacuum Breaker	9029-077-001	9029-077-001	9029-266-001	1
*	Screw	9545-008-026	9545-008-026	9545-008-026	4
6	New Front Mount Soap Box, 2 port			9807-087-001	1
7	Fitting, Cross			8615-118-001	
*	Clamp, Vacuum Breaker End	8654-117-014	8654-117-014	8654-117-014	1
9	Hose, Vacuum Breaker to Tub Injection Tube	9242-461-001	9242-461-001	9242-461-001	1
10	Flow resistor	9475-002-002	9475-002-002	9475-002-002	2
11	1/2 inch hose, cut to length	9242-453-001	9242-453-001	9242-453-001	AR
12	7/8 inch hose, cut to length		9242-466-001	9242-466-001	AR
13	Flow resistor		9475-002-002	9475-002-003	3
*	Tub Fill Inlet Cap	0935-135-002	0935-135-002	0935-135-002	AR
14	Plate-Water Valves, Mounting	9452-813-001	9452-814-001	9452-814-001	1
15	Nut, #10-32UNF, 2B	8460-413-002	8460-413-002	8460-413-002	4

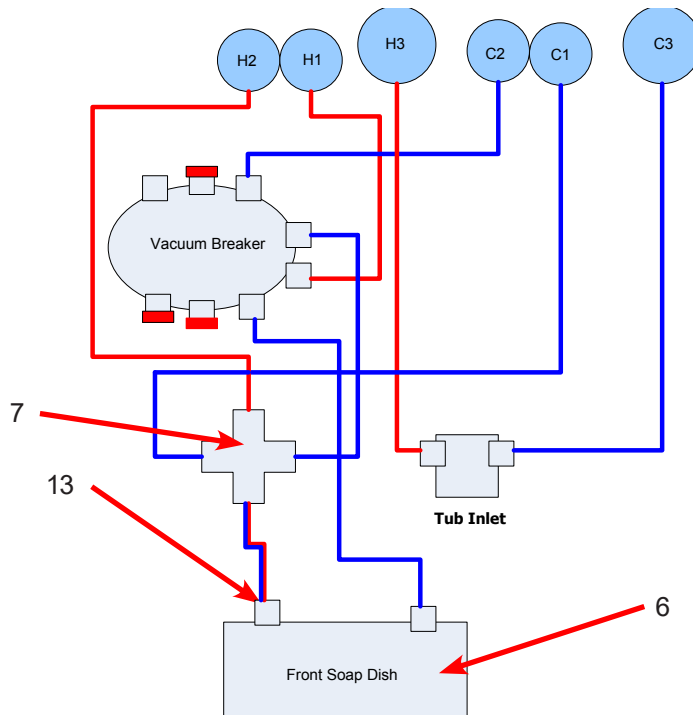

New Front Soap Box Design

Water Inlet Valve Breakdown Part # by Model

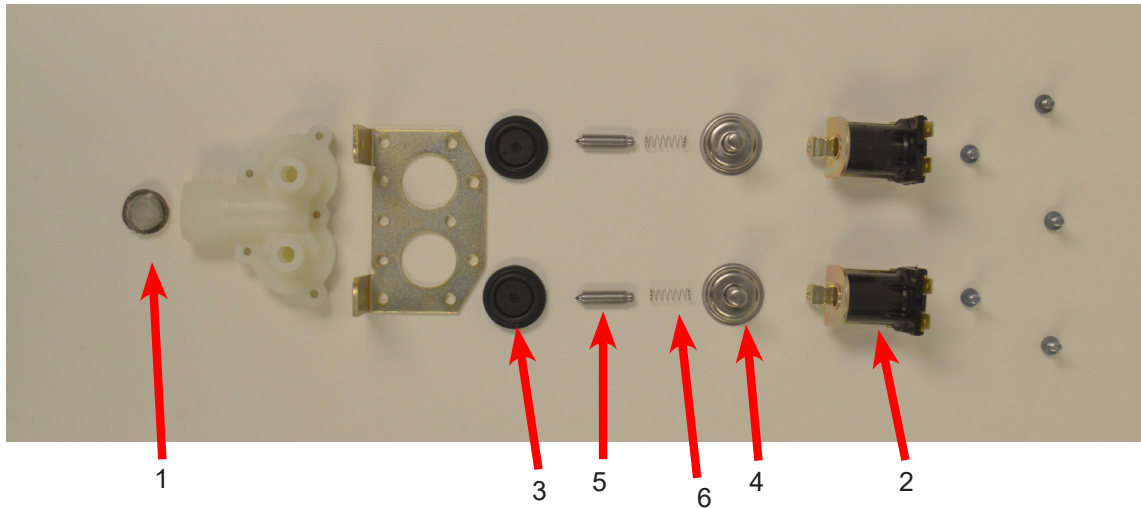

Key	Description	T-675	T-975	T-1475	
*	Valve, Water Inlet (includes 1 thru 6)	9379-183-012	9379-183-012	9379-183-012	2
1	Screen, Inlet end of valve	9555-056-001	9555-056-001	9555-056-001	2
2	Coil Assy., 120 V Invensys	9089-017-001	9089-017-001	9089-017-001	2
*	Diaphragm Invensys (EPDM)	9118-049-001	9118-049-001	9118-049-001	2
*	Diaphragm Invensys (Viton)	9118-049-002	9118-049-002	9118-049-002	2
3	Diaphragm Invensys (EPDM NSF)	9118-049-003	9118-049-003	9118-049-003	2
4	Guide, Solenoid Invensys	9211-021-002	9211-021-002	9211-021-002	2
5	Armature Invensys	9015-008-001	9015-008-001	9015-008-001	2
6	Spring, Armature Invensys	9534-298-001	9534-298-001	9534-298-001	2

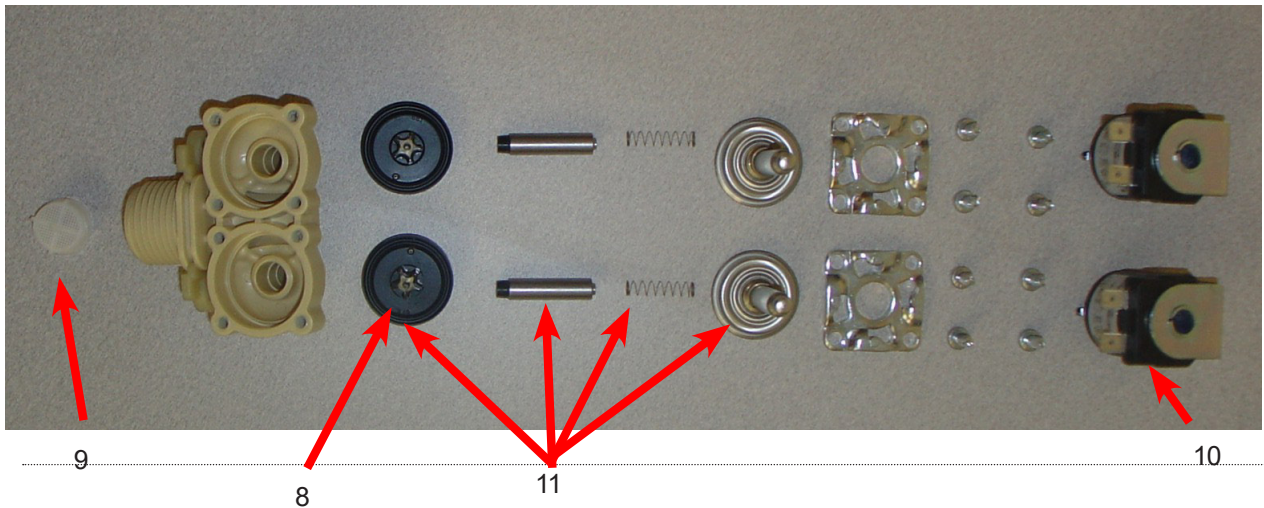

Optional Water Valve

Key	Description	T-675	T-975	T-1475	QTY
*	Dual Coil Water Valve Mueller	9379-192-001	9379-192-001	9379-192-001	1
7	Valve Water Body Complete(no coil)	9379-192-002	9379-192-002	9379-192-002	1
8	Diaphragm Mueller	9118-054-001	9118-054-001	9118-054-001	2
9	Filter Mueller	9183-046-001	9183-046-001	9183-046-001	2
10	Coil Mueller	9089-051-001	9089-051-001	9089-051-001	2
11	Diaphragm Assembly Mueller Includes	9785-001-001	9785-001-001	9785-001-001	2

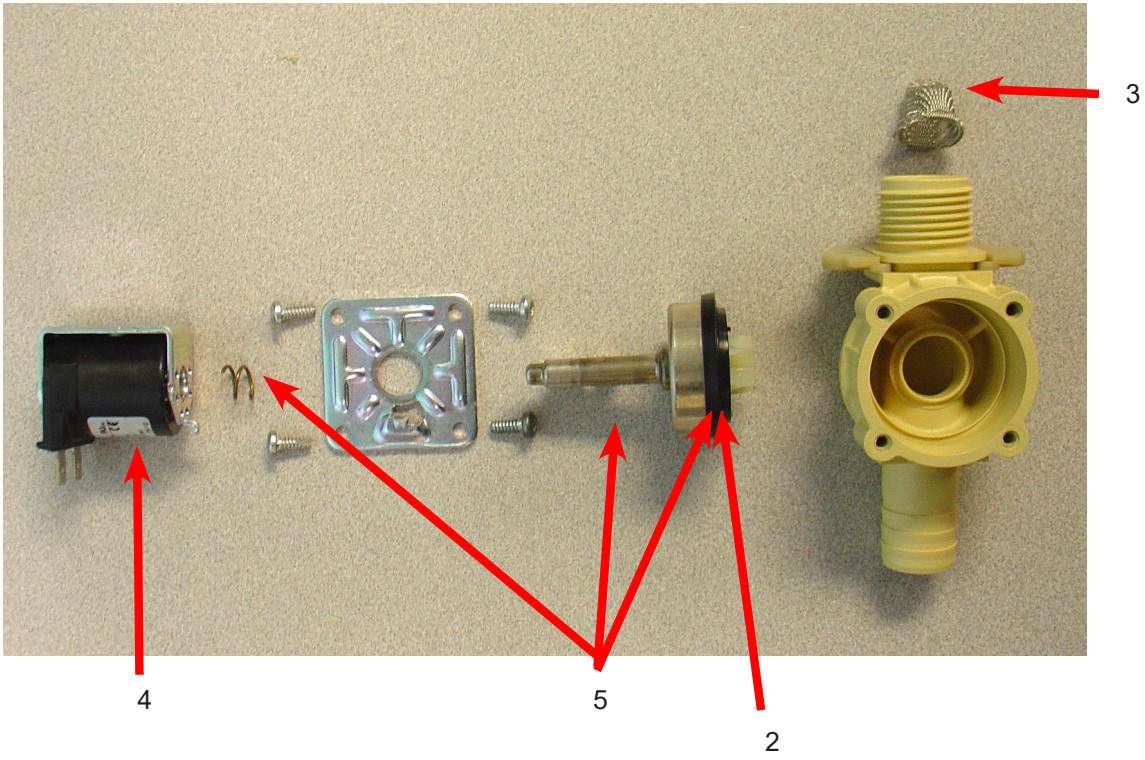

Key	Description	T-675	T-975	T-1475	QTY
*	Single Coil Water Valve Mueller		9379-194-001	9379-194-001	1
1	Valve Water Body Complete (no coil)		9379-194-002	9379-194-002	1
2	Diaphragm Mueller		9118-055-001	9118-055-001	1
3	Filter Mueller		9183-046-001	9183-046-001	1
4	Coil Mueller		9089-051-001	9089-051-001	1

Drain Valve Group Part # by Model

Key	Description	Part Number	Qty
1	Valve, Drain (includes #2 thru #11)	9379-202-001	1
2	Body, Valve (w/ball)	9064-072-001	1
3	Motor & Gear Train (complete)	9914-137-023	1
4	Plate, Motor Mtg	9452-538-001	1
5	Screw	8639-994-001	1
6	Spring, Drive	9534-339-001	1
7	Screw	9545-054-001	1
8	Screw	9545-054-002	1
9	Seal, V Packer	9532-134-001	1
10	Washer	8641-584-001	1
11	Pin, Main Drive	9451-196-001	1
*	Plate (spacers needed for replacement motor mtg. plate)	9538-149-001	1
12	Kit - Seal Replacement	9732-327-001	1

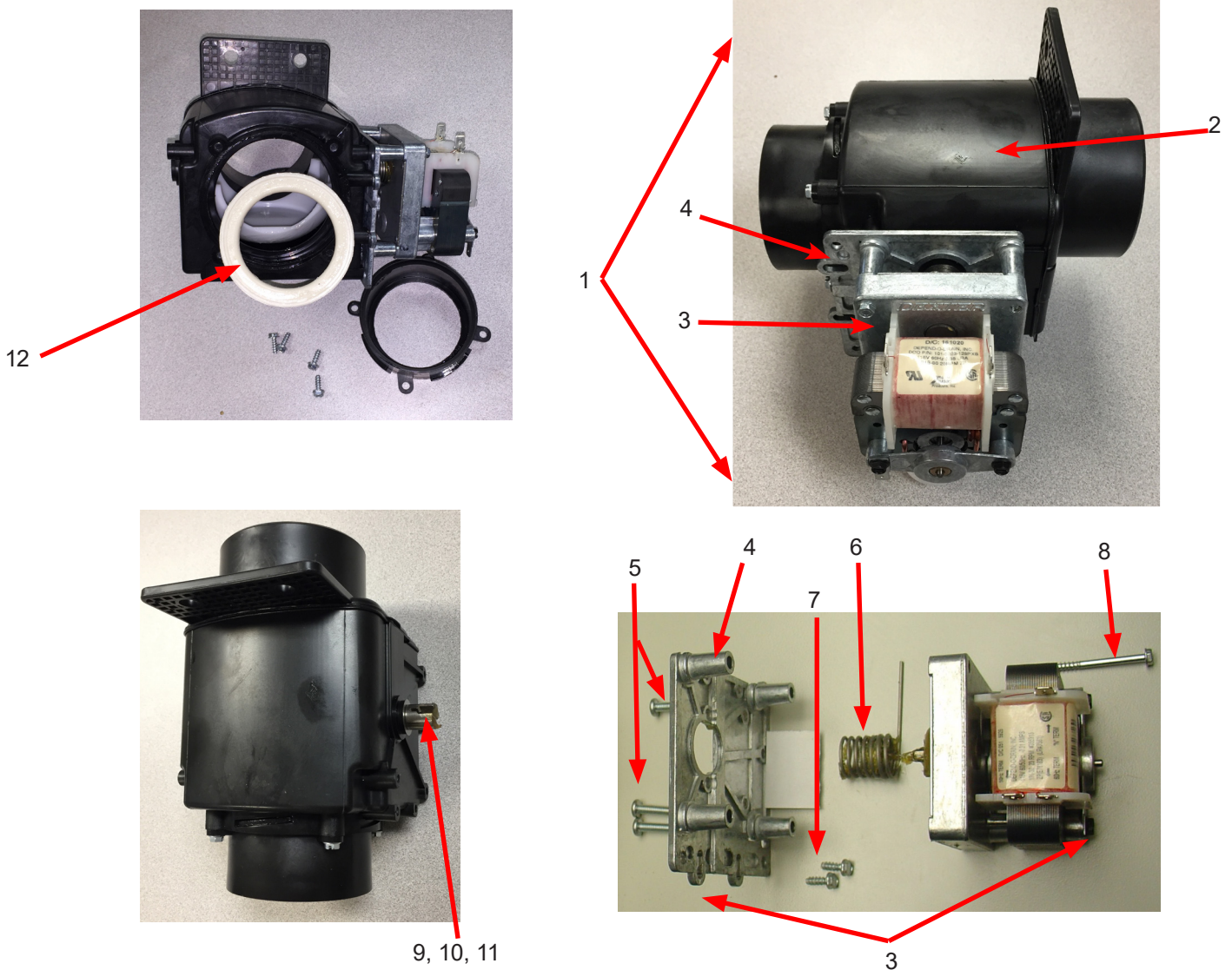

Chassis and Drain Part # by Model

Key	Description	T-675	T-975	T-1475	
1	Base Assy,Frame	9945-143-002	9945-155-002	9945-133-002	1
2	Outer Tub Assy.	9930-169-001	9930-158-001	9930-155-001	1
*	Tub & Cylinder Assy.	9869-035-004	9869-027-004	9869-026-001	1
3	Tub Front	9974-014-002	9974-011-001	9974-012-001	1
*	Gasket, Tub Front	9206-421-004	9206-421-002	9206-421-003	1
4	Ring Assy, Tub Mtg-Front Clamp	9950-063-001	9950-055-001	9950-061-001	1
5	Bolt, Top Front Ring 3/8"-16 x 3"	9545-029-009	9545-029-009	9545-029-009	1
6	Nut 3/8"-16	8640-415-001	8640-415-001	8640-415-001	1
7	Bolt, 1/2" -13 x 2" Tub feet to base	9545-017-013	9545-017-013	9545-017-013	2
8	Nut, Wizloc 1/2" x 13	8640-417-005	8640-417-005	8640-417-005	2
9	Washer, Flat 1/2"	8641-581-026	8641-581-026	8641-581-026	2
10	Hose, Tub to Drain Valve	9242-464-001	9242-459-001	9242-459-001	1
11	Clamp, Hose (Tub to Drain Valve)	8654-117-014	8654-117-014	8654-117-008	2
12	Valve, Drain	9379-202-001	9379-202-001	9379-202-001	1
*	Screw, Valve to Base 1/4Bx3/4	9545-030-002	9545-030-002	9545-030-002	2
*	Washer, Flat 1/4	8641-581-018	8641-581-018	8641-581-018	2
13	Hose, Drain Valve to Tube	9242-457-001	9242-457-001	9242-457-002	1
*	Clamp, Hose (Drain Valve to Tube)	8654-117-014	8654-117-014	8654-117-014	2
14	Tube Assy, Drain	9915-124-002	9915-120-004	9915-129-002	1
15	Clamp, Hose (Tube to Frame Bracket)	8654-117-014	8654-117-014	8654-117-014	1
*	Bracket, Drain Tube		9029-162-002		1
*	Screw Tube (Bracket to Base 1/4Bx3/4)	9545-030-002	9545-030-002	9545-030-002	2
16	Hose, Overflow Tub To Drain Tube	9242-449-002	9242-449-003	9242-449-005	1
*	Clamp, Hose	8654-117-018	8654-117-018	8654-117-018	2
17	Tube, Suds overflow	9242-463-004	9242-463-004	9242-463-006	1
*	Clamp, Hose	8654-117-008	8654-117-008	8654-117-008	2
18	Hose, Pressure switch	9242-175-002	9242-175-007	9242-175-004	1
*	Clamp, Hose	8654-117-015	8654-117-015	8654-117-015	1
*	Anchor-wiretie,adhesive	9004-007-001	9004-007-001	9004-007-001	1
*	Strap-tie,adjustableratchet	9544-040-001	9544-040-001	9544-040-001	1
19	Bracket-switch,prox	9029-309-001	9029-309-001	9029-309-001	1
*	Washer-flat	8641-581-040	8641-581-040	8641-581-040	1
*	Screw-hxcap,5/8-11x3/4	9545-060-005	9545-060-005	9545-060-005	1
20	Switch-prox,18mm,shld,60"	9539-498-001	9539-498-001	9539-498-001	1
21	Sensorassembly-thermistor,10k	9501-005-002	9501-005-002	9501-005-002	1
*	Sealer-pipe	8538-132-000	8538-132-000	8538-132-000	1

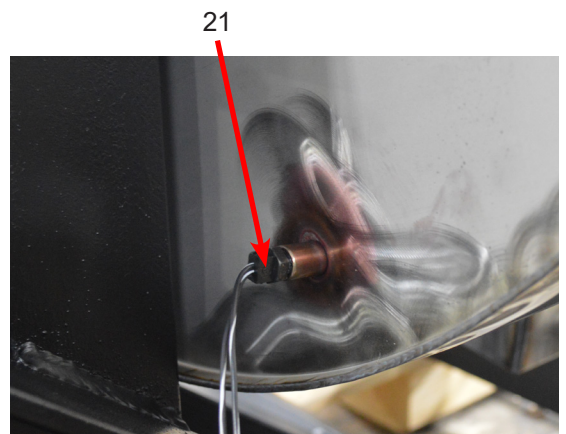
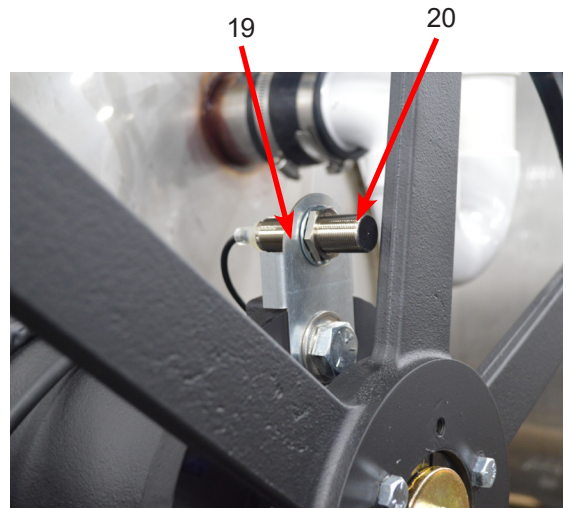
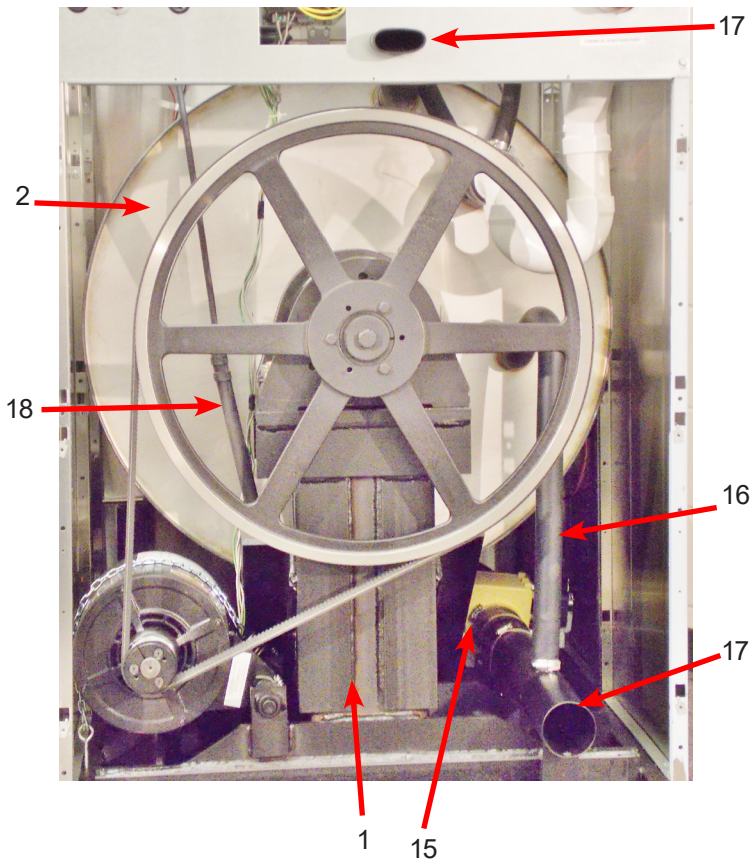
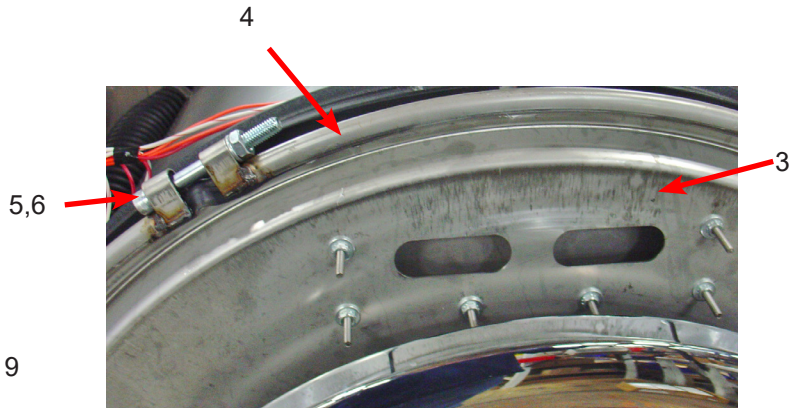
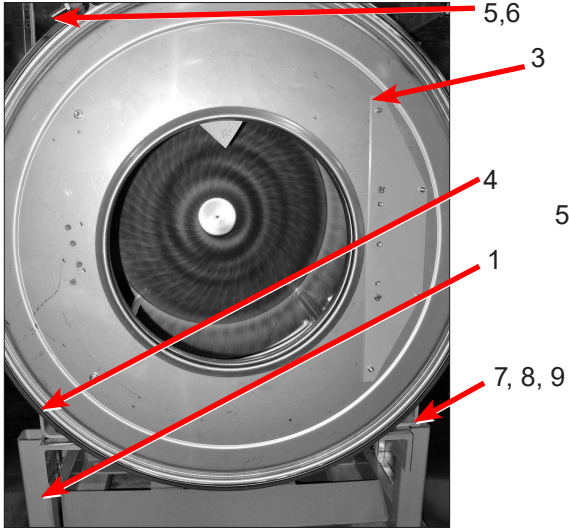
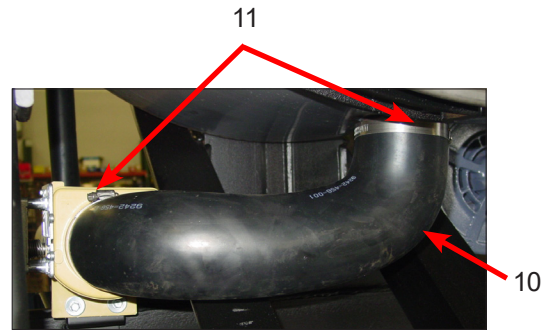
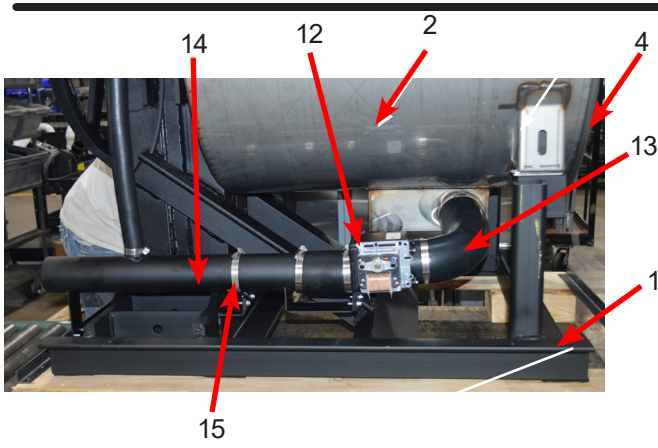

Key	Description	T-675	T-975	T-1475	
	Contrlrassy-trgh, opl,60hz	9857-243-001	9857-245-001	9857-246-001	1
1	Troughassy-control	9839-019-001	9839-019-001	9839-019-001	1
2	Transformer-dualsecondary	8711-017-001	8711-017-001	8711-017-001	1
*	Screw-hxwshrhnduct,#10bx1/2	9545-008-026	9545-008-026	9545-008-026	4
*	Lockwasher #10	8641-582-006	8641-582-006	8641-582-006	4
3	Terminalblockassembly-power	9897-026-005	9897-026-005	9897-026-005	2
*	Screw-panhdr,#8abx1/2	9545-045-012	9545-045-012	9545-045-012	4
*	Wiringharn-ctrl,graph,can,wshr	9627-922-002	9627-922-002	9627-922-002	1
4	Pcbassy-maincontrol	9799-027-001	9799-027-001	9799-027-001	1
5	Pcbassy-relay	9799-028-001	9799-028-001	9799-028-001	2
*	Screw-hxwshrhnduct,#10bx1/2	9545-008-026	9545-008-026	9545-008-026	12
6	Wiringharness-main,t-650-1450	9627-933-001	9627-933-001	9627-933-001	1
7	Wiringharness-chemical,v2.0wshr	9627-927-001	9627-927-001	9627-927-001	1
8	Wireasy,2.0,	8220-158-017	8220-158-025	8220-158-029	1
9	Wiringharness-drsw/vfd,stp	9627-928-001	9627-928-001	9627-928-003	1
10	Clamp-cable,3/16"	8654-125-005	8654-125-005	8654-125-005	1
*	Screw-hxwshrhnd,8bx1/4	9545-045-001	9545-045-001	9545-045-001	1
*	Wiringharness-cntrl/relay,v2.0	9627-921-001	9627-921-001	9627-921-001	2
11	Wireasy-jumper,v2.0,relaypcb	8220-159-005	8220-159-005	8220-159-005	1
12	Wireasy-jumper,v2.0,relaypcb	8220-159-006	8220-159-006	8220-159-006	1
*	Screw-hxwshrhds,10-32tx1/2 grn	9545-008-027	9545-008-027	9545-008-027	2
*	Lockwasher #10	8641-582-006	8641-582-006	8641-582-006	2
*	Standoff-twistlok	9527-002-002	9527-002-002	9527-002-002	4
13	Sensorassy-pressure,2level	9732-315-001	9732-315-001	9732-315-001	1
*	Support-pcb,3/8",edge Holding	9548-285-001	9548-285-001	9548-285-001	4
14	Wiringharness-ps,t-650-1450	9627-926-001	9627-926-001	9627-926-001	1
*	Wireasy-org,71/2"	8220-062-052	8220-062-052	8220-062-052	1
*	Wireasy-wht/org,9"	8220-062-053	8220-062-053	8220-062-053	1
15	Fuseholderassembly	9200-001-002	9200-001-002	9200-001-002	2
*	Fuse-2a,slow,1/4x1-1/4	8636-018-005	8636-018-005	8636-018-005	1
*	Fuse-1.5a,fast,1/4x1-1/4	8636-018-001	8636-018-001	8636-018-001	1
*	Label-fuse,2.5a	8502-716-002	8502-716-002	8502-716-002	1
*	Label-fuse,1.5a	8502-716-001	8502-716-001	8502-716-001	1
*	Wireasy-red,71/2"	8220-062-059	8220-062-059	8220-062-059	2
*	Wireasy-org,71/2"	8220-062-052	8220-062-052	8220-062-052	2
*	Label-waterlevelsettings,opl	8502-775-001	8502-775-001	8502-775-001	1
16	Elecperiph-powersupply,12v	9150-054-001	9150-054-001	9150-054-001	1
*	Screw-pnhdr,6bx3/8	9545-031-005	9545-031-005	9545-031-005	2
17	Wiringharness-pwrsup,v2.0wshr	9627-923-001	9627-923-001	9627-923-001	1
18	Wiringharness-thermist,v2.0wsh	9627-930-001	9627-930-001	9627-930-001	1
*	Screw-hxwshrhnduct,#10bx1/2	9545-008-026	9545-008-026	9545-008-026	5
19	Standoff-wiresaddle/arrowhead			9527-007-001	1
20	Support,Trough	9081-171-001	9081-172-001	9081-173-001	1
21	Channel-trough,mtg		9081-188-001	9081-155-001	1
*	Angle-support,trough	9003-368-001			1
*	Screw-hxwshd,10bx1/4	9545-008-001	9545-008-001	9545-008-001	2
*	Plate-wireclips		9452-823-001		1
*	Screw-hxwshrhnduct,#10bx1/2	9545-008-026	9545-008-026	9545-008-026	AR
*	Assembly, Vibration Sensor (includes sensor, bracket, & hardware)	9501-012-002	9501-012-002	9501-012-002	1

Electrical Components - Top Compartment

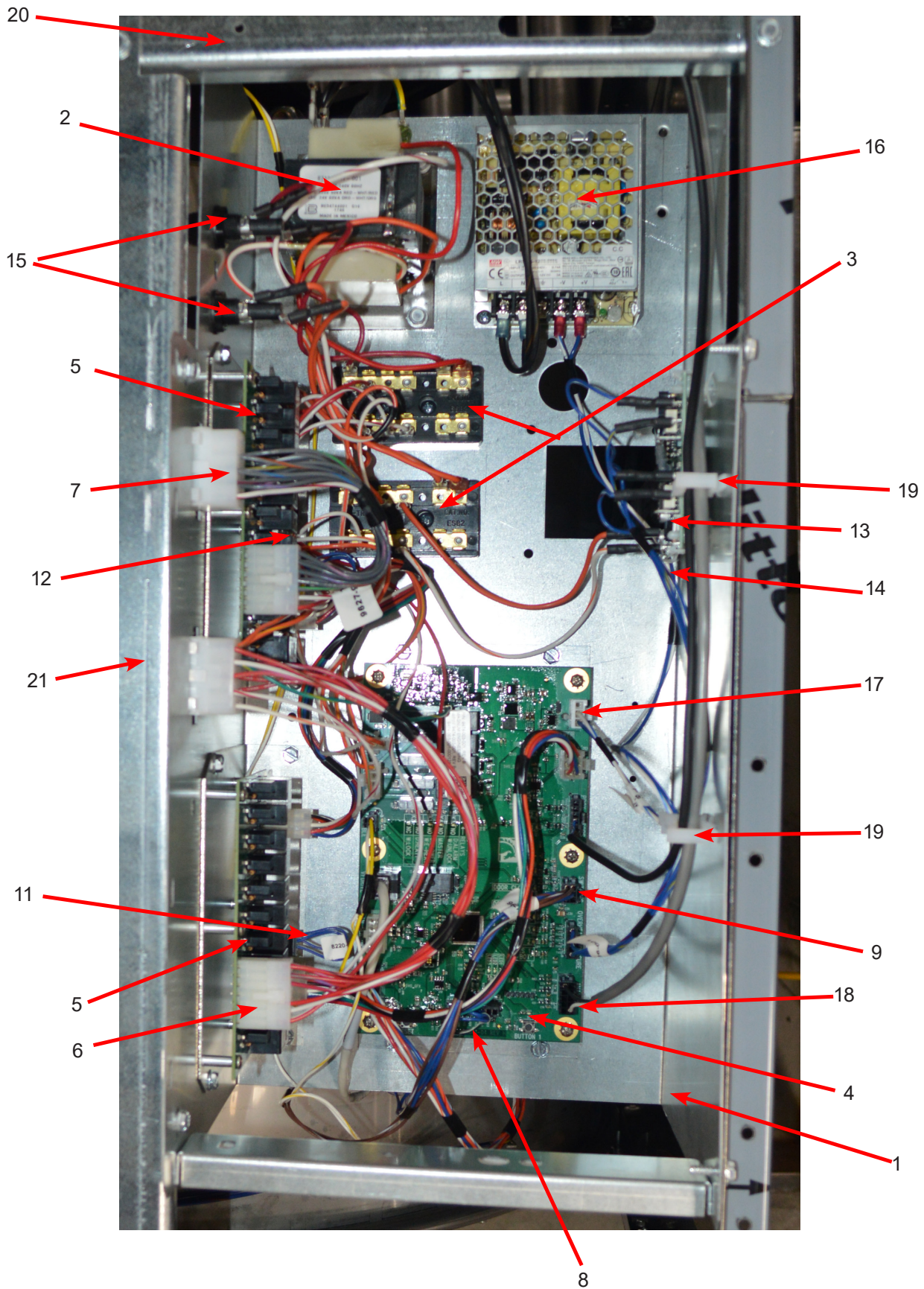

Key	Description	T-675	T-975	T-1475	
1	Panel Control Assembly(panel only)	9989-599-001	9989-600-001	9989-601-001	1
*	Screw-Hxwshrhndct #10Bx 1/2"(Control Panel To side Panel)	9545-008-026	9545-008-026	9545-008-026	4
*	Plate -Latch, Top	9452-625-001	9452-625-001	9452-625-001	AR
*	Nut Hexkeps #8-32	8640-412-005	8640-412-005	8640-412-005	AR
*	Post-locator,top	9467-024-001			2
*	Nut-hexkeps,#6-32	8640-411-003			2
*	Locator Panel	9355-001-001	9355-001-001	9355-001-001	AR
*	Screw FillHDCR 10Bx1/2" Guide	9545-008-023	9545-008-023	9545-008-023	AR
*	Shield, PCB	9550-184-001	9550-184-001	9550-184-001	1
*	Nut, #8-32	8640-412-005	8640-412-005	8640-412-005	3
2	Button-control,2.0,opl	9035-063-001	9035-063-001	9035-063-001	1
3	Window-display,lcd(w/gasket)	9635-021-002	9635-021-002	9635-021-002	1
4	Contrlassy-display,2.0,opl,wsh	9857-230-003	9857-230-003	9857-230-003	1
5	Nut-hexkeps,#6-32	8640-411-003	8640-411-003	8640-411-003	4
6	Cableassy-usb,snopin	9806-024-001	9806-024-001	9806-024-001	1
*	Wiringharness-doorlock	9627-936-003	9627-936-001	9627-936-004	1
*	Harness, P5/Pressure Switch	9627-926-001	9627-926-001	9627-926-001	1
*	Kit-Emergency Stop, O-Series (includes #X, #Y)	9732-223-004	9732-223-004	9732-223-004	1
7	Button-emergencystop,w/latch	9035-061-002	9035-061-002	9035-061-002	1
8	Spacer-pcb,#8x1/8	9538-157-005	9538-157-005	9538-157-005	2
9	Plate-mounting,stopbutton	9452-725-001	9452-725-001	9452-725-001	1
10	Nut-hexkeps,#8-32	8640-412-005	8640-412-005	8640-412-005	2
11	Switch-contactblock,dpst,nc	9539-499-001	9539-499-001	9539-499-001	1
*	Nameplate,Control Panel (one piece) Black	9412-243-001	9412-245-001	9412-246-001	1
12	Motor Ass'y, Door Locking (see Door Lock Group for parts breakdown)	9892-015-003	9892-015-003	9892-015-003	1
13	Thermoactuator - 24VAC	9586-001-003	9586-001-003	9586-001-003	2
14	Hex Nuts (mounting Door Lockassy. to control panel)	8640-412-005	8640-412-005	8640-412-005	4
15	Nut-Spring	8640-399-008	8640-399-008	8640-399-008	2
16	Screw, #10B x 1/2	9545-008-026	9545-008-026	9545-008-026	2
*	Anchor-wiretie,adhesive	9004-007-001	9004-007-001	9004-007-001	2
*	Strap-tie,adjustableratchet	9544-040-001	9544-040-001	9544-040-001	2
17	Doorlockassembly-complete	9885-024-001	9885-024-001	9885-024-001	1
	Shim-doorlock,thin	9552-037-001	9552-037-001	9552-037-001	3
	Screw-hxhdcap,1/4-20x3/4	9545-018-014	9545-018-014	9545-018-014	3
	Lockwasher-exttooth,1/4	8641-582-007	8641-582-007	8641-582-007	3
18	Rod-pull,doorlock	9497-225-017	9497-225-015	9497-225-016	1

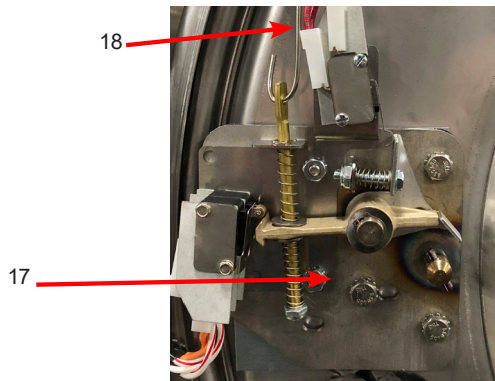

Control Panel Part # by Model

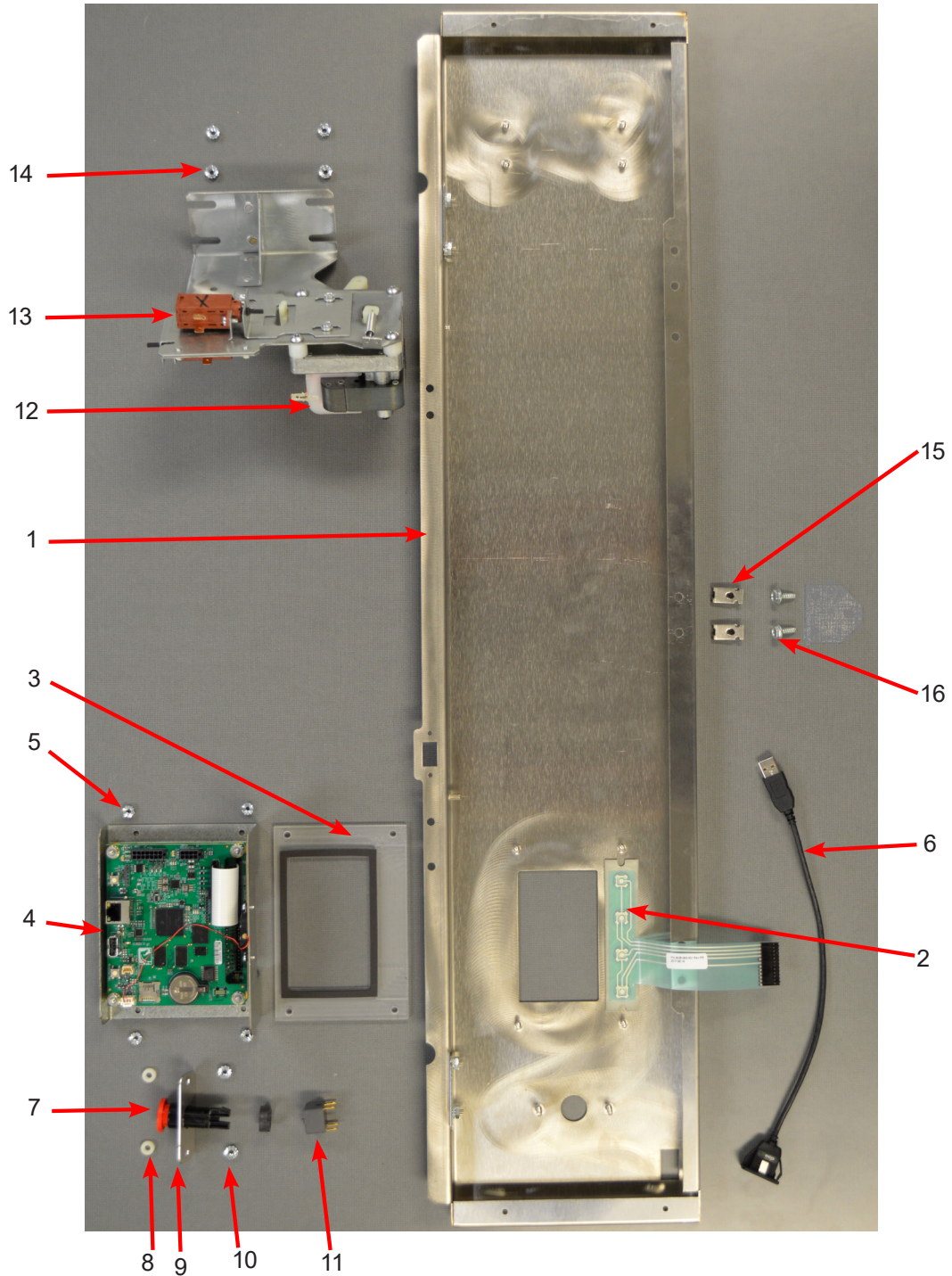

Labels and Diagrams All O-Series Models

Key	Description	T-675	T-975	T-1475	
*	Operators Manual	8514-290-001	8514-290-001	8514-290-001	1
	Wiringlabel-diagram/inform	9507-011-001	9507-004-001	9507-012-001	
	Wiringlabel-schematic	9508-011-001	9508-004-001	9508-012-001	
	Instruct-washerinstall	8507-448-001	8507-448-001	8507-448-001	
	Instructions-chemicalhoseinstl	8507-268-001	8507-268-001	8507-268-001	
	Instruct-transformerconn,60hz	8507-449-001	8507-449-001	8507-449-001	
	Card-warranty(dexter)	8507-300-001	8507-300-001	8507-300-001	
	Label-warning	8502-639-001	8502-639-001	8502-639-001	
	Label-keeppanelinplace	8502-760-001	8502-760-001	8502-760-001	
	Labels-blank,sets of 4	8502-670-001	8502-670-001	8502-670-001	
	Label-warning,high voltage	8502-614-004	8502-614-004	8502-614-004	
	Label-warning,door opening,blk	8502-757-001	8502-757-001	8502-757-001	
	Label-warning,risk of injury,blk	8502-759-001	8502-759-001	8502-759-001	
	Label-fusing&installation	8502-619-004	8502-619-003	8502-619-008	
	Label-warning/notice,washer	8502-761-001	8502-761-001	8502-761-001	
	Label-connections,injection	8502-776-001	8502-776-001	8502-776-001	
	Label-instruc,chemicalinstall	8502-653-001	8502-653-001	8502-653-001	
	Label-injectorassembly	8502-666-001	8502-666-001	8502-666-001	
	Label-blank,oneacross(carton)	8502-669-002	8502-669-002	8502-669-002	
	Label-dispenser,black			8502-745-001	



Risk of Injury Label



Door Label



Top Dispenser Label Front Soap Dish

WN0675XB-12EO Diagram

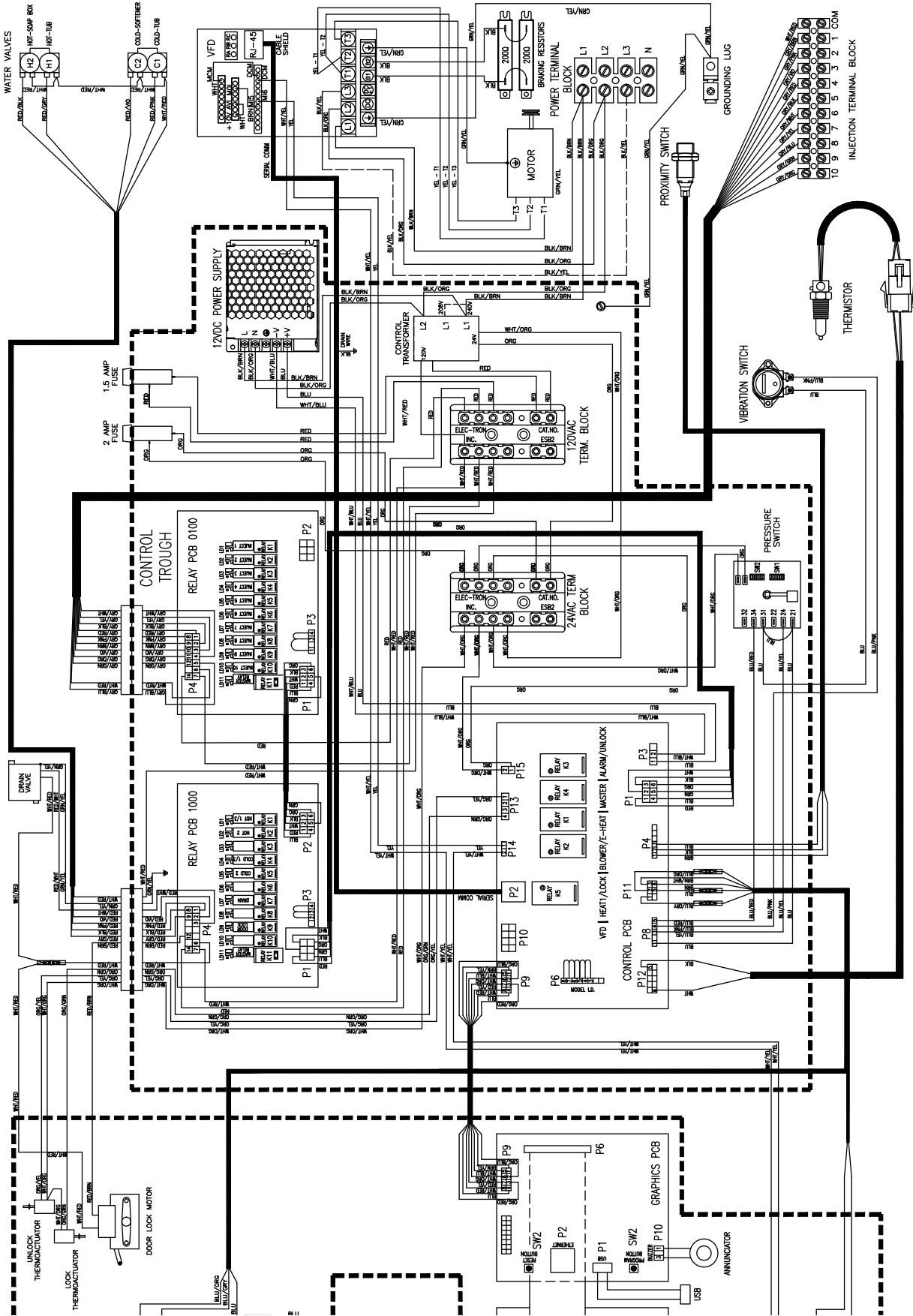

P/N 9507-056-001PR
 40 LB OPL EXPRESS PLUS, VF DRIVE
 WN0675XB-12-02A-____-X

WIRING DIAGRAM 208 - 240V, 1/3PH, 60HZ

WN0675XB-12EO Schematic

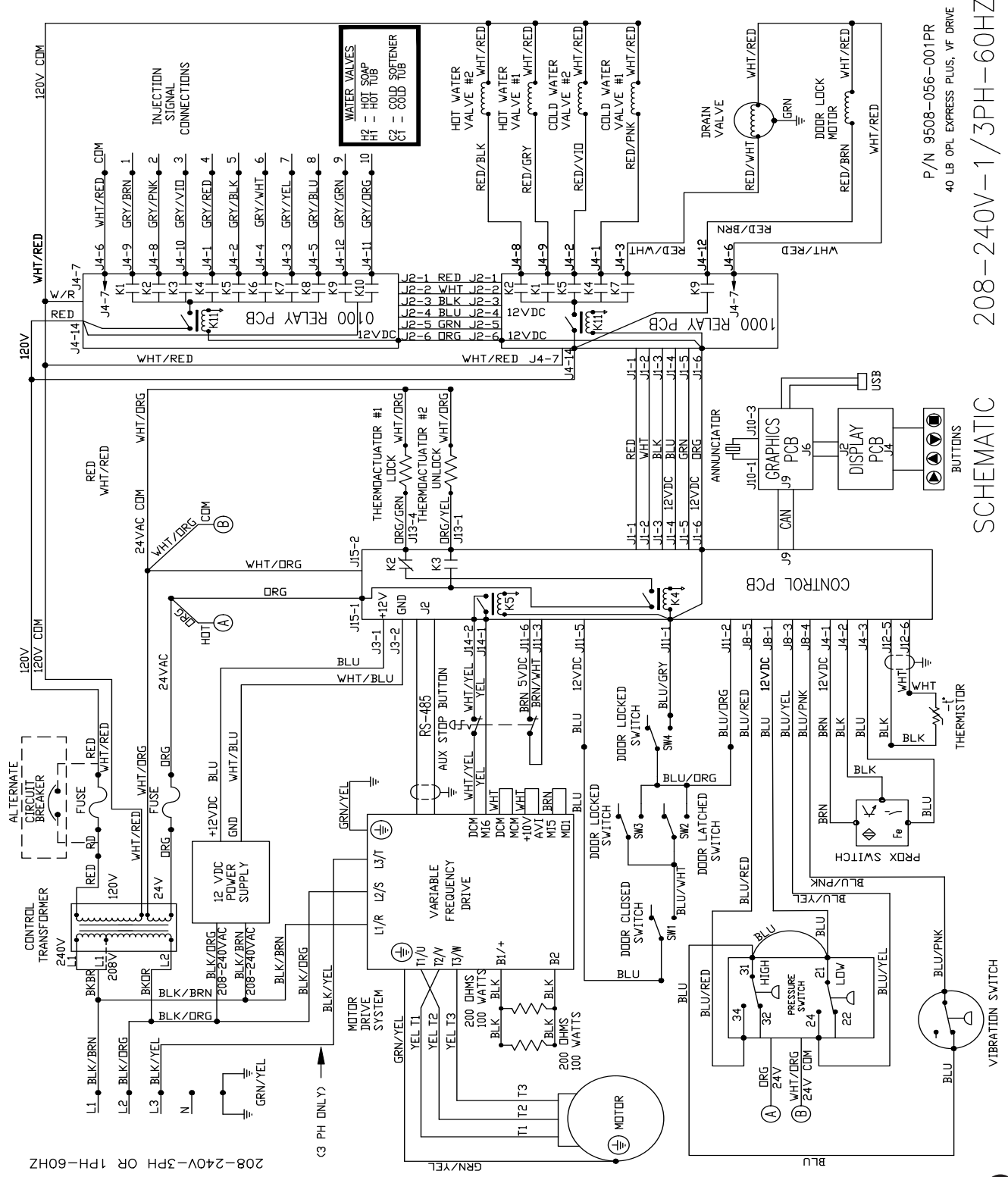

208-240V-3PH OR 1PH-60HZ

P/N 9508-056-001PR
40 LB OPL EXPRESS PLUS, VF DRIVE

208-240V-1/3PH-60HZ

SCHEMATIC

WN0975XB-12EO Schematic

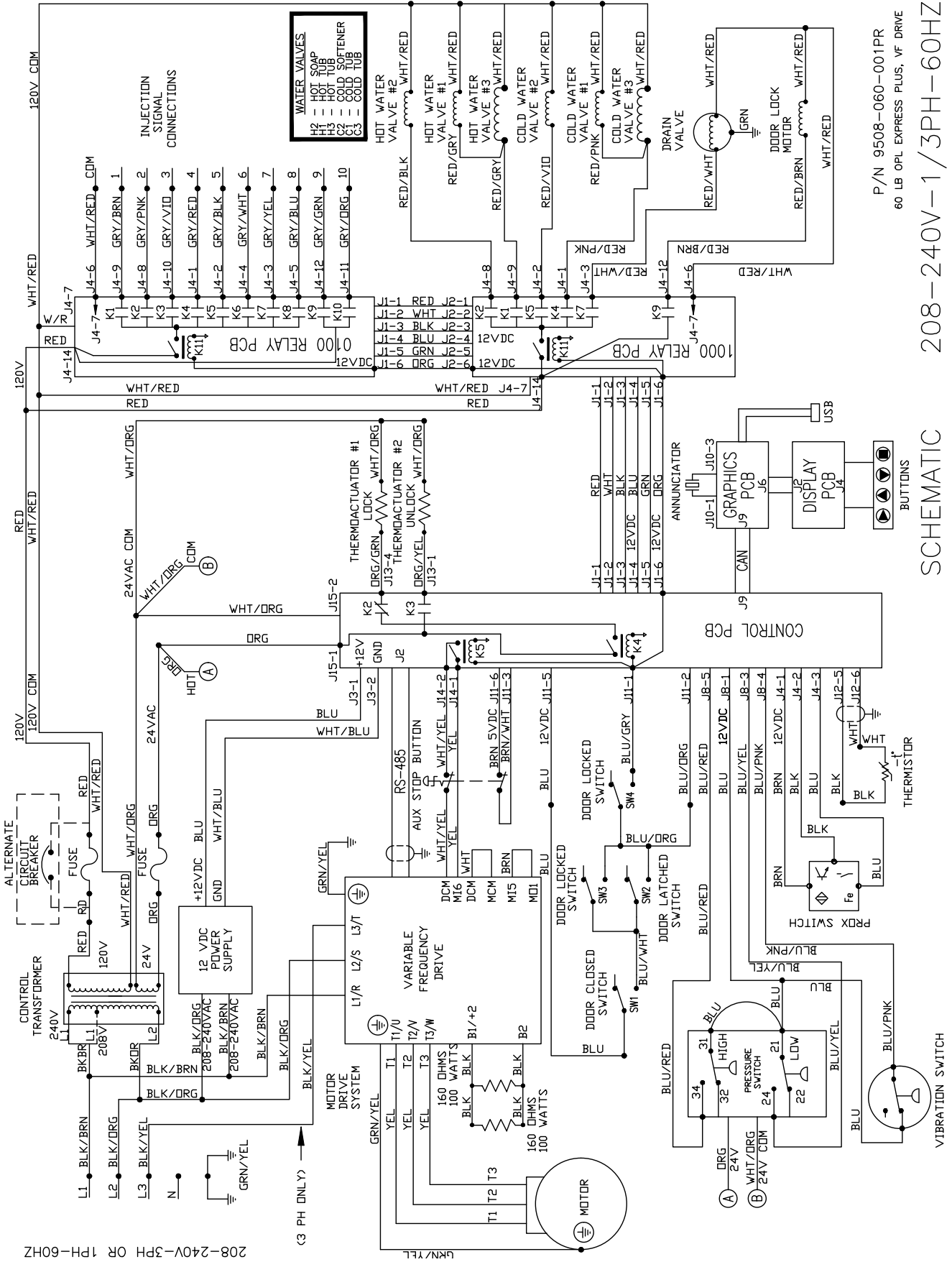

208-240V-3PH OR 1PH-60HZ

P/N 9508-060-001PR
60 LB OPL EXPRESS PLUS, VF DRIVE

SCHEMATIC

208-240V-1/3PH-60HZ

WN0975XB-12EO Diagram

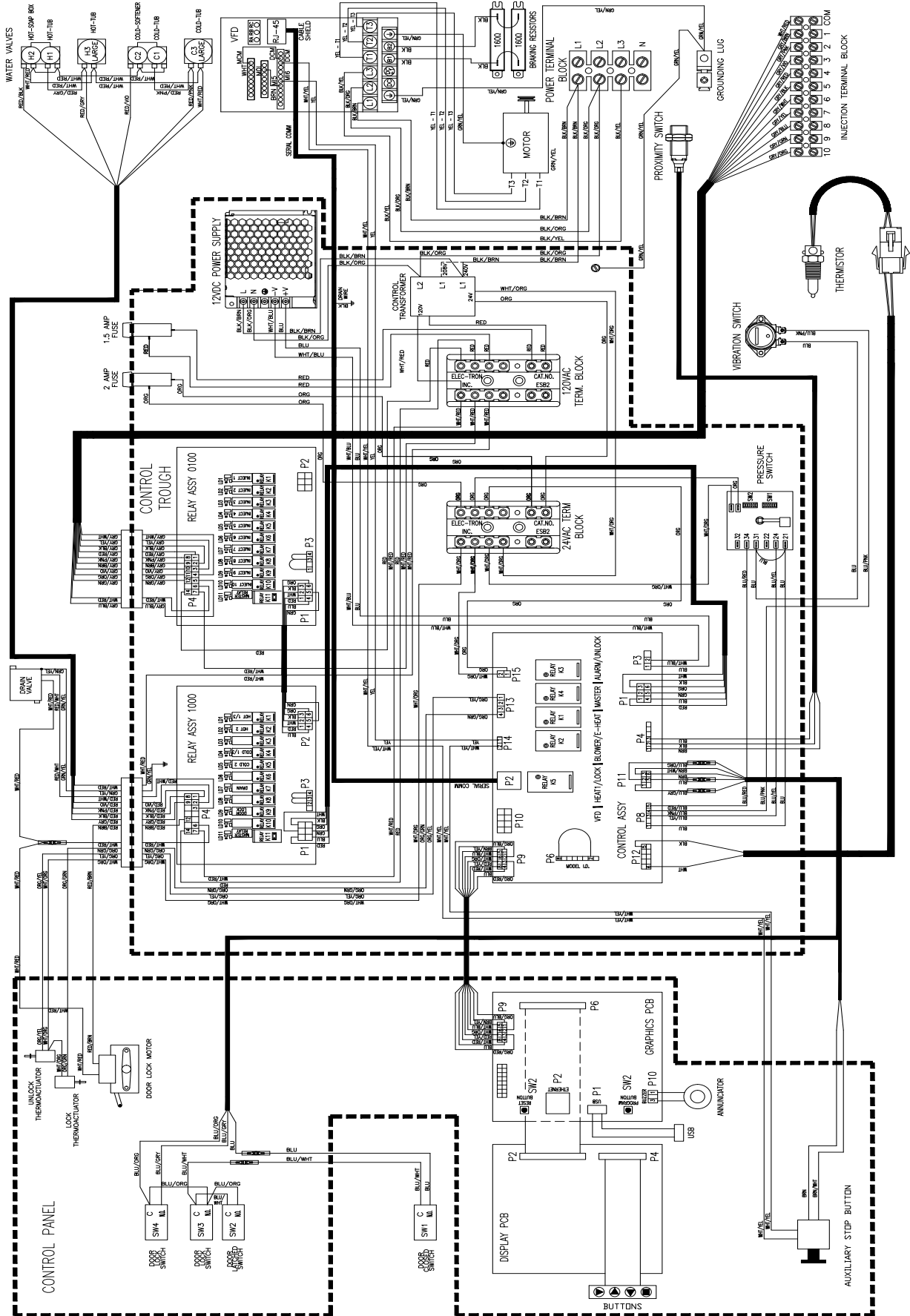

P/N 9507-060-001PR
60 LB. OIL EXPRESS PLUS, VF DRIVE
WN0975XB-12-02A-_____X

WIRING DIAGRAM 208 - 240V, 1/3PH, 60HZ

WN1475XB-12EO Schematic

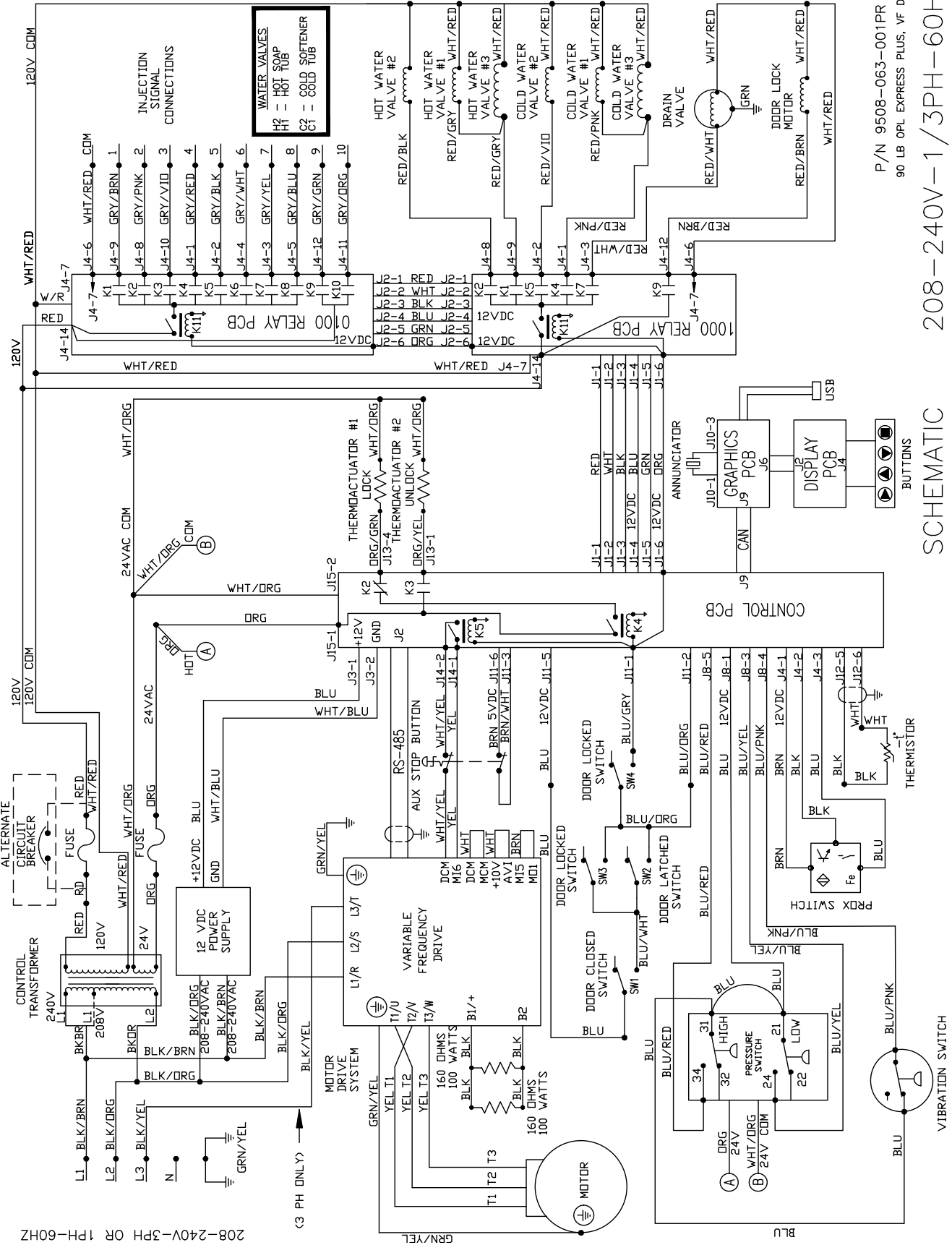

P/N 9508-063-001PR
 90 LB OPL EXPRESS PLUS, VF DRIVE

208-240V-1/3PH-60HZ
 SCHEMATIC

208-240V-3PH OR 1PH-60HZ

WN1475XB-12EO Diagram

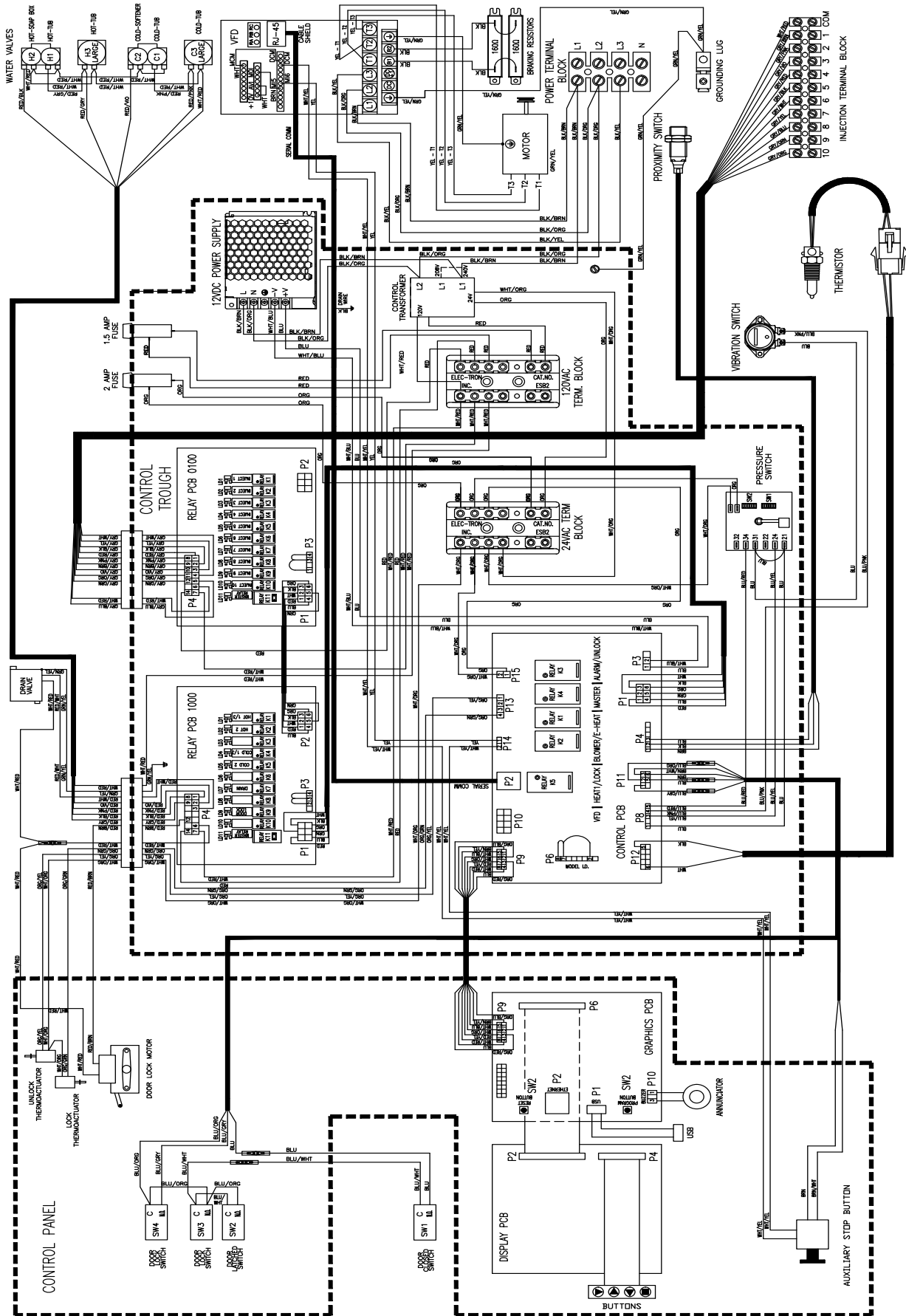

P/N 9507-063-001PR
 90 LB. OPL. EXPRESS PLUS, VF DRIVE
 WN1475XB-12.00A-____-__

WIRING DIAGRAM 208 - 240V, 1/3PH, 60HZ



Section :9

Parts 50Hz



Section :12

Maintenance

Preventative Maintenance

Daily

- Step 1:** Check that the loading door remains securely locked and cannot be opened during an entire cycle.
- Step 2:** Clean the top, front, and sides of the cabinet to remove residue.
- Step 3:** Clean the soap dispenser and lid and check that all dispenser mounting screws are in-place and tight.
- Step 4:** Check the loading door for leaks. Clean the door seal of all foreign matter.
- Step 5:** Leave the loading door open to aerate the washer when not in use.

Quarterly

- Step 1:** Make sure the washer is inoperative by switching off the main power supply.
- Step 2:** Check the V-belts for wear and proper tension.
- Step 3:** Clean lint and other foreign matter from around motor.
- Step 4:** Check all water connections for leaks.
- Step 5:** Check the drain valve for leaking and that it opens properly.
- Step 6:** Wipe and clean the inside of the washer and check that all electrical components are free of moisture and dust.
- Step 7:** Remove and clean water inlet hose filters. Replace if necessary.
- Step 8:** Check anchor bolts. Retighten if necessary.