

CAUTION: LABEL ALL WIRES PRIOR TO DISCONNECTION WHEN SERVICING CONTROLS. WIRING ERRORS CAN CAUSE IMPROPER AND DANGEROUS OPERATION. VERIFY PROPER OPERATION AFTER SERVICING.

ATTENTION. AU MOMENT DEL'ENTRIEN DES COMMANDES, ÉTIQUETEZ TOUS LES FILS AVANT DE LES DÉBRANCHER. DES ERREURS DE CÂBLAGE PEUVENT ENTRAÎNER UN FONCTIONNEMENT INADÉQUAT ET DANGEREUX. S'ASSURER QUE L'APPAREIL FONCTIONNE ADÉQUATEMENT UNE FOIS L'ENTRETIEN TERMINÉ.

NOTES:

1. DOOR SWITCHES—N.O., CLOSED WHEN DOORS ARE CLOSED.
2. DRYER STARTS WHEN THE DOORS ARE CLOSED, A CYCLE IS SELECTED, AND THE START BUTTON IS PUSHED. THERE IS AN AUTOMATIC COOL DOWN AT THE END OF THE CYCLE.
3. CENTRIFUGAL SWITCH—N.O., CLOSSES WHEN MOTOR IS UP TO SPEED.
4. REFER TO OWNER'S MANUAL FOR DESCRIPTION OF OPERATION AND REQUIREMENTS FOR HEATING CIRCUIT.
5. WITH A DC MICROAMMETER, FLAME CURRENT CAN BE MEASURED AT TEST POINTS. READING SHOULD BE 0.7µA DC OR HIGHER.

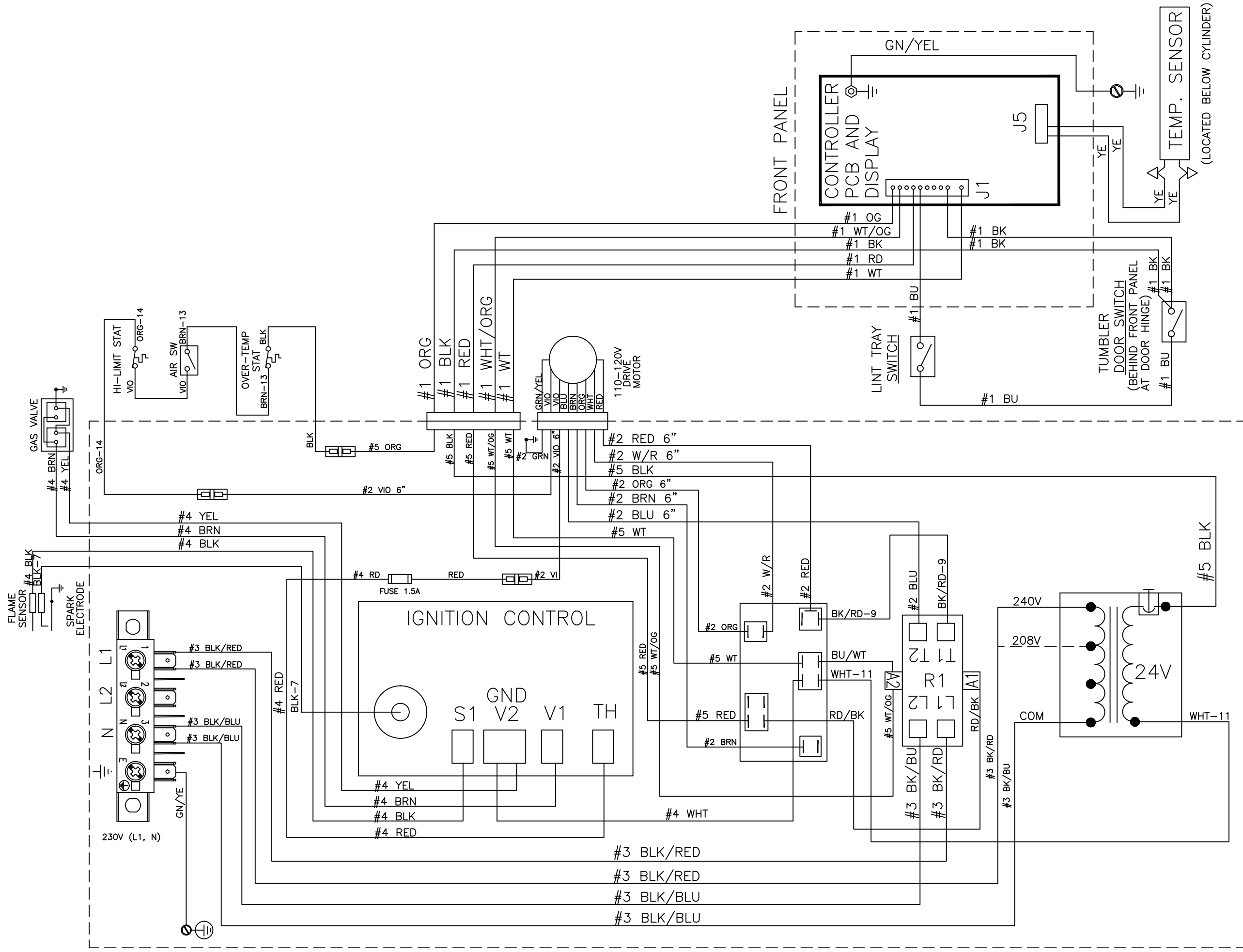

9506-857-001PR WIRING DIAGRAM DNS020N_-39_B_Z-__X

IMPORTANT: RETAIN THIS ELECTRICAL DIAGRAM FOR SERVICE.