







OPL 30 Cycle 100G PARTS & SERVICE MANUAL

Including Electric & Steam Heated Models 50Hz. & 60Hz.

Equipment Safety Warnings

Symbols and Terminology Used in this Equipment

⚠ DANGER	Indicates an imminently hazardous situation, which if not avoided, will result in death or serious injury.
⚠ WARNING	Indicates a potentially hazardous situation, which if not avoided could result in death or serious injury.
⚠ CAUTION	Indicates a potentially hazardous situation which, if not avoided, may result in minor or moderate injury. It may also be used to alert against unsafe practices. Minor burns, pinch points that result in bruises and minor chemical irritation.
NOTICE	Indicates information or a company policy that relates directly or indirectly to the safety of personnel or protection of property.
	This is the user caution symbol. It indicates a condition where damage to the equipment resulting in injury to the operator could occur if operational procedures are not followed. TO REDUCE THE RISK OF DAMAGE OR INJURY , refer to accompanying documents; follow all steps or procedures as instructed.
	This is the electrical hazard symbol. It indicates that there are DANGEROUS HIGH VOLTAGES PRESENT inside the enclosure of this product. TO REDUCE THE RISK OF FIRE OR ELECTRIC SHOCK , do not attempt to open the enclosure or gain access to areas where you are not instructed to do so. REFER SERVICING TO QUALIFIED SERVICE PERSONEL ONLY
	Caution! There are sharp edges on various sheet metal parts internal to the enclosure. Use safety consciousness when placing or moving your hands while working in the interior of this equipment.
	Caution! To reduce the risk of damage to the Water Inlet Valve, do not supply inlet water with a temperature that exceeds 70° C. Caution! To reduce the risk of fire or explosion, do not operate this equipment in any hazardous classified (ATEX) environment.



Warning! Do not operate equipment if door glass is damaged in any way.



Warning! Keep clear of rotating parts.



Prohibited! Do not enter this equipment or space.



Prohibited! Do not step or stand on this equipment.



Prohibited! Do not operate without all guards and covers in place.









Prohibited! Do not operate without all guards and covers in place.



Prohibited! Do not wash clothing impregnated with flammable liquids (petrochemical).



Prohibited! Do not allow children to play in or around equipment.

	<p>Indicates an imminently hazardous situation, which if not avoided, <u>will result</u> in death or serious injury.</p>
	<p>Indicates a potentially hazardous situation, which if not avoided <u>could result</u> in death or serious injury.</p>
	<p>Indicates a potentially hazardous situation which, if not avoided, <u>may result</u> in minor or moderate injury. It may also be used to alert against unsafe practices. Minor burns, pinch points that result in bruises and minor chemical irritation.</p>
	<p>Indicates information or a company policy that relates directly or indirectly to the safety of personnel or protection of property.</p>
	<p>This is the user caution symbol. It indicates a condition where damage to the equipment resulting in injury to the operator could occur if operational procedures are not followed. TO REDUCE THE RISK OF DAMAGE OR INJURY, refer to accompanying documents; follow all steps or procedures as instructed.</p>
	<p>This is the electrical hazard symbol. It indicates that there are DANGEROUS HIGH VOLTAGES PRESENT inside the enclosure of this product. TO REDUCE THE RISK OF FIRE OR ELECTRIC SHOCK, do not attempt to open the enclosure or gain access to areas where you are not instructed to do so. REFER SERVICING TO QUALIFIED SERVICE PERSONEL ONLY</p>
	<p>Caution! To reduce the risk of fire or explosion, do not operate this equipment in any hazardous classified (ATEX) environment.</p>



WARNING



- All washers must be installed in accordance to all applicable electrical, plumbing and all other local codes.

- These installation and operation instructions are for use by qualified personnel only. To avoid injury and electrical shock, do not perform any servicing other than that contained in the installation and operation instructions, unless qualified.



Do not install washers in an explosive atmosphere.



- Care must be stressed with all foundation work to ensure a stable unit installation, eliminating possibilities of excessive vibration.

- Foundation must be level within 13 mm to ensure proper washer operation.



Do not operate washer if door glass is damaged in any way.



Do not wash clothing impregnated with flammable liquids (petrochemical).



WARNING







	<p>Children should be supervised to ensure they do not operate or play in or around equipment.</p>
	<p>Keep all panels in place to protect against electrical shock and injury and add rigidity to washer.</p>

This appliance is not intended for use by persons (including children) with reduced physical, sensory or mental capabilities, or lack of experience and knowledge, unless they have been given supervision or instruction concerning use of the appliance by a person responsible for their safety.

A washer should not be allowed to operate if any of the following occur:

- **Excessive high water level.**
- **Machine is not connected to a properly earthed circuit.**
- **Door does not remain securely locked during the entire cycle.**
- **Vibration or shaking from an inadequate mounting or foundation**

	<p>Warning! Do not operate equipment if door glass is damaged in any way.</p>
	<p>Warning! Keep clear of rotating parts.</p>
	<p>Prohibited! Do not enter this equipment or space.</p>
	<p>Prohibited! Do not step or stand on this equipment.</p>
	<p>Prohibited! Do not operate without all guards and covers in place.</p>
	<p>Prohibited! Do not operate without all guards and covers in place.</p>
	<p>Prohibited! Do not wash clothing impregnated with flammable liquids (petrochemical).</p>
	<p>Prohibited! Do not allow children to play in or around equipment.</p>

	<p>Prohibited! Do not attempt to open, touch, or proceed before referring to the manual or unless qualified.</p>
	<p>Mandatory! Read all supporting documentation before operating or maintaining equipment.</p>
	<p>Mandatory! Disconnect power before servicing equipment.</p>
	<p>Mandatory! Lock out and tag out before servicing this equipment.</p>
	<p>Mandatory! Disconnect water supply before servicing equipment.</p>
	<p>Mandatory! Children should be supervised to ensure they do not operate equipment.</p>

Dexter Safety Guidelines



WARNING

These washers are equipped with devices and features relating to their safe operation. To avoid injury or electrical shock, do not perform and service, unless qualified to do so.

FOR SAFETY

1. Always shut off power and water supply and also discharge capacitors before servicing.
2. Do not overload the washer.
3. Do not attempt to open door if cylinder is in motion or contains water.
4. Do not mechanically force or override door lock in any way.
5. Do not bypass any safety devices of this washer.
6. Do not use volatile or flammable substances in or near this washer.
7. Keep all panels in place. They protect against shock and injury and add rigidity to the washer.

A machine should not be allowed to operated if any of the following occur:

- Excessively high water level.
- Machine is not connected to a properly grounded circuit.
- Loading door does not remain securely locked during the entire cycle.
- Vibration or shaking from an inadequate mounting or foundation.

To activate your warranty, be sure to return your warranty form to the factory. Please have serial number and model ready when calling for assistance.

Table of Contents

Section 1:

Machine Mounting & Installation

T-600 Deminsions	12 & 14
T-900 Deminsions	13, 15
T-1200 Deminsions.....	13,16

Section 2:

Machine Installation & Operating Instructions

Basic Installation.....	19
Electrical Connections & Fusing Requirements .	21
Liquid Chemical Injection.....	22
Machine Operating Instructions	23-25

Section 3:

Machine Programming Instructions

Programming Instructions	28-29
30 Preset Cycle Descriptions.....	30-38

Section 4:

Trouble Shooting

Rapid Advance Mode.....	40
Diagnostic Test Cycle.....	41
Input/Output Board Diagram.....	42-43
Common Troubleshooting Solutions Pages..	44-50
Electrical Schematic / Bath Descriptions	51-52

Section 5:

Machine Service Procedures

Top, Front, Back Panel Removal.....	54
Drain Valve Access.....	54
Drain Valve Cleaning	54
Detergent Dispenser	54
Vacuum Breaker/ Air Gap	55
Water Valves	55
Door Lock Assembly / Operation.....	55
Adjustment of the Door Lock Assembly	55-56
Adjusting the Loading Door	57
Loading Door Removal	57
Loading Door Hinge Removal.....	57
Loading Door Disassembly	58

Loading Door Reassembly	58
Control Panel Name Plate Decal	58
Name Plate Removal	58
Re-Installation of Name Plate.....	58
Outer Cabinet Removal	59
Door Locking Gear Motor	60
Thermoactuators	60
Lock Thermoactuator	60
Unlock Thermoactuator	60
Drive Belt Removal.....	60
Tub Back, Bearing and Cylinder Assembly ..	61-62
Basket Pulley, Bearing Housing, Water Seals & Tub Back (600)	63
Bearing Housing Assembly T-900, T-1200	64-65
T-900,T-1200 Cylinder Basket Assembly	64
Reassembly T-900, T-1200 Cylinder	
60, 80 & 90Lb. Pound Water Seals.....	66-67
Outer Tub T-900, T-1200.....	66
T-600, T-900, T-1200 Bolt Torque Chart	67
Microprocessor, CPU.....	68
Control Mounting Trough.....	68
Circuit Breaker/Fuse	68
PCB Transformer Step Down.....	68
Controls Transformer.....	68
Main Relay Input/Output Board.....	68
Display PCB	68
Electronic Pressure Switch	69-70
Power Connection Terminal Block	71
Delta Variable Frequency Drive	71
Delta VFD Motor Leads.....	71
Delta VFD Dynamic Braking Resistors.....	71
Delta VFD Cooling Fan	71
Maxium Spin Speed Adjustment.....	72
Motor Winding Resistance Chart.....	73
Schematics	74-76

Section 6:

Parts Data	
Accessories.....	80
Wiring Harness Group.....	81
Labels and Diagrams All Models	82
Control Panel Group	83
Cabinet and Front Panel Group	84-86
Detergent Dispensing	86-87
Rear View Access	88-93
Cylinder, Seals & Bearings	93-97
Door Lock (Solenoid and Gear).....	98-99
Loading Door and Hinge Group	100-102
Drain Valve Group	103
Water Inlet Valve Breakdown	104
Water Inlet Group	106-107
Chassis and Drain Group.....	108-111
Electrical Components - Top Compartment	112-115

Section 7:

Electric Heated	
Models.....	121-132

Section 8:

Steam Heated Kit and	
Accessories.....	133-142

Section 9:

50 Hz Models	143
50 Hz Heated Models Parts.....	144-153
50 Hz Schematics.....	154-156

Section 10:

Preventative Maintenance	157-159
--------------------------------	---------

Section 1:

Machine
Dimensions

Specifications for below models are outlined in this book:

	Model	hz	Phase	Voltage	Heat Option	G's
9999-662-001	Wn0600xa-12en2x-sskcs-usx	60	1 - 3ph	208 - 240v		100
9999-662-003	Wn0600ea-13en2x-sskcs-usx	60	3ph	208 - 240v	Heated Electric	100
9999-665-001	Wn0900xa-12en2x-sskcs-usx	60	1 - 3ph	208 - 240v		100
9999-665-003	Wn0900ea-13en2x-sskcs-usx	60	3ph	208 - 240v	Heated Electric	100
9999-669-001	Wn1200xa-12en2x-sskcs-usx	60	1 - 3ph	208 - 240v		100
9999-669-003	Wn1200ea-13en2x-sskcs-usx	60	3ph	208 - 240v	Heated Electric	100
	Model	hz	Phase	Voltage	Heat Option	G's
9999-662-002	Wn0600xa-39xn2x-sskcs-vrx	50	1ph	230-240v		100
9999-662-004	Wn0600ea-68xn2x-sskcs-vrx	50	3ph	400v	Heated Electric	100
9999-662-005	Wn0600ea-59cn2x-sskcs-vrx	50	1ph	230v	Heated Electric	100
9999-665-002	Wn0900xa-39xn2x-sskcs-vrx	50	1ph	230-240v		100
9999-665-004	Wn0900ea-68xn2x-sskcs-vrx	50	3ph	400v	Heated Electric	100
9999-669-002	Wn1200xa-39xn2x-sskcs-vrx	50	1ph	230-240v		100
9999-669-004	Wn1200ea-68xn2x-sskcs-vrx	50	3ph	400v	Heated Electric	100

T-600 Mounting Dimensions

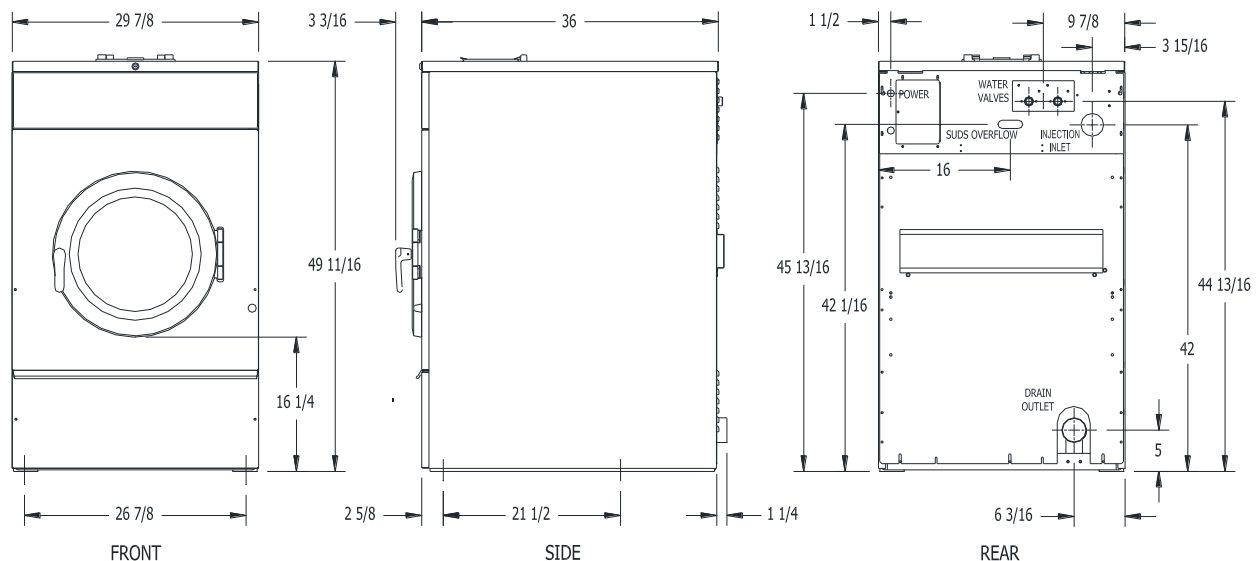

T-900 Mounting Dimensions

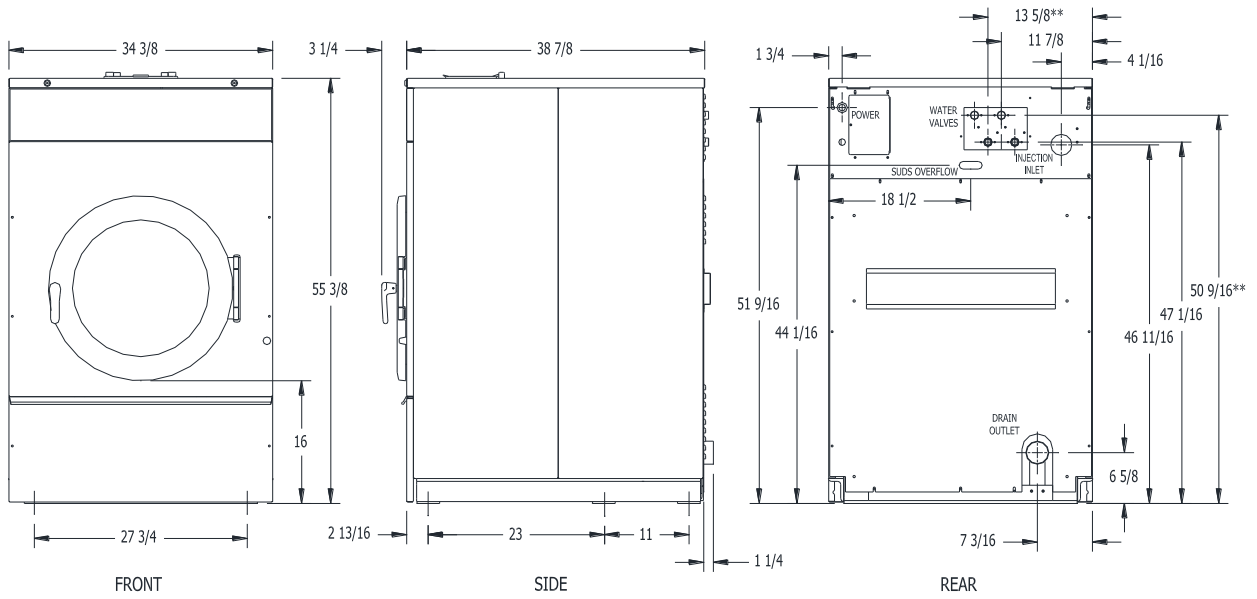

T-1200 Mounting Dimensions

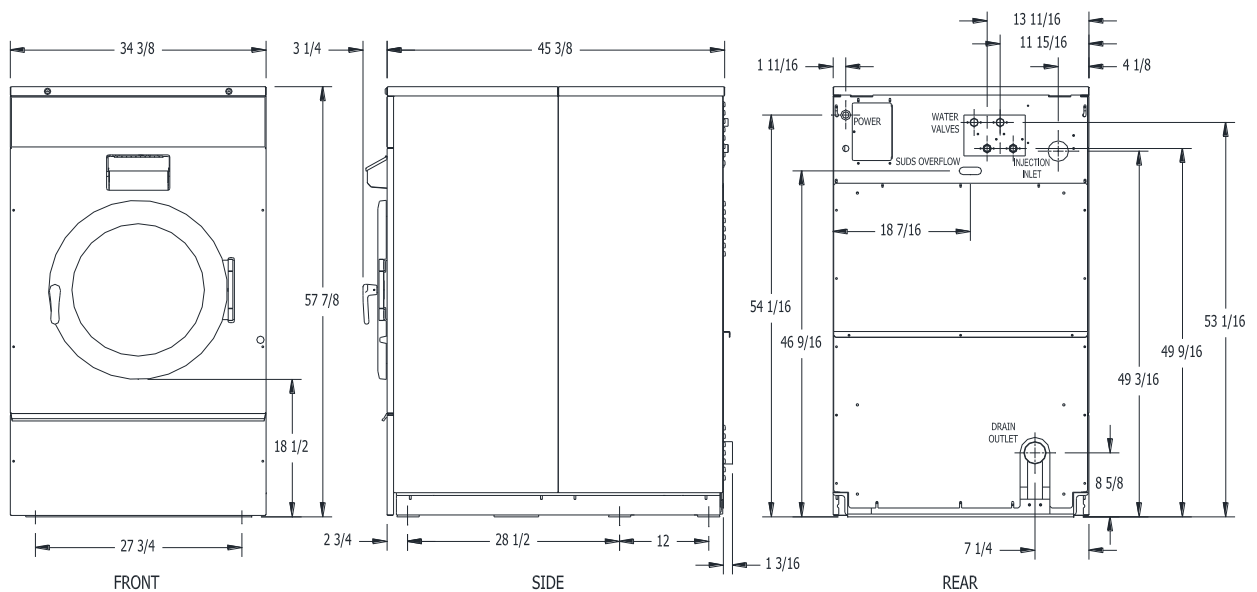

T-600 Mounting Pad Dimensions

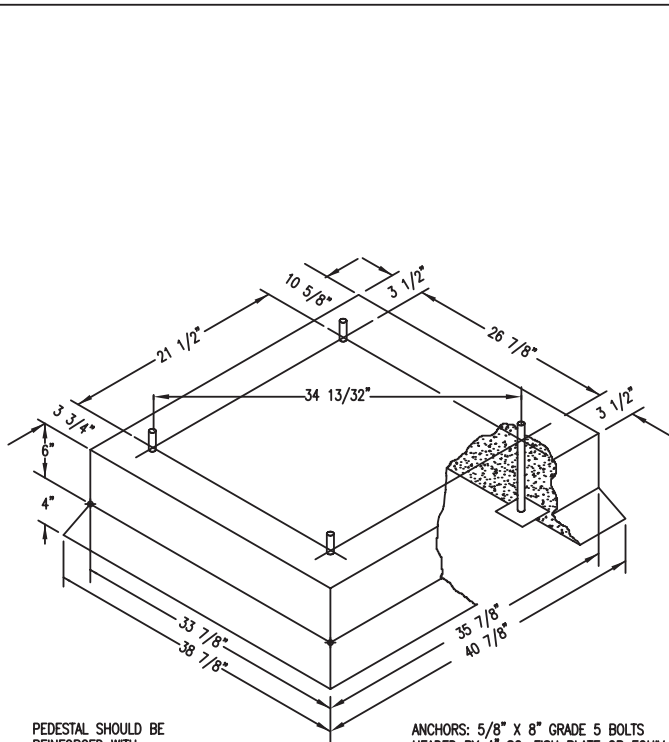

CONCRETE PEDESTAL MOUNTING
Figure 1-1

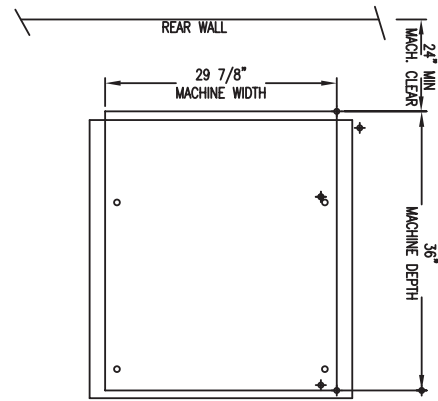
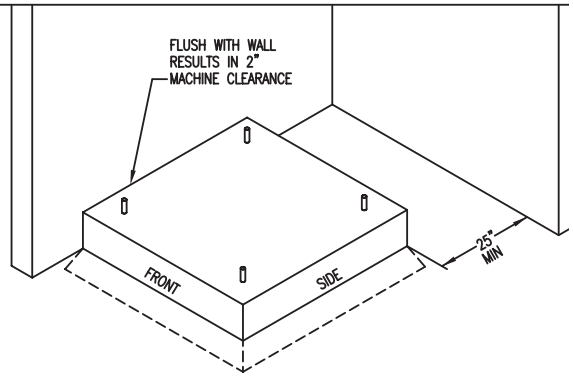

FLOOR OUTLINE
Figure 1-2

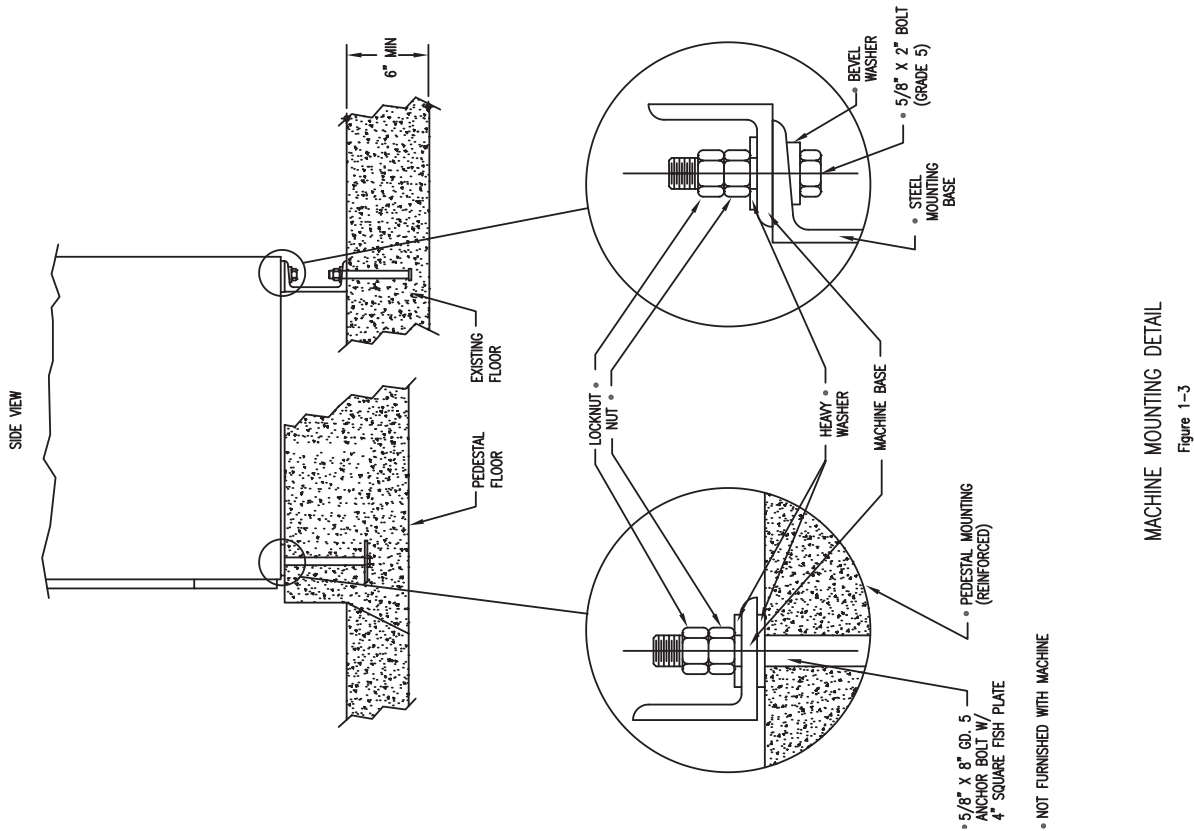

T-900 Mounting Pad Dimensions

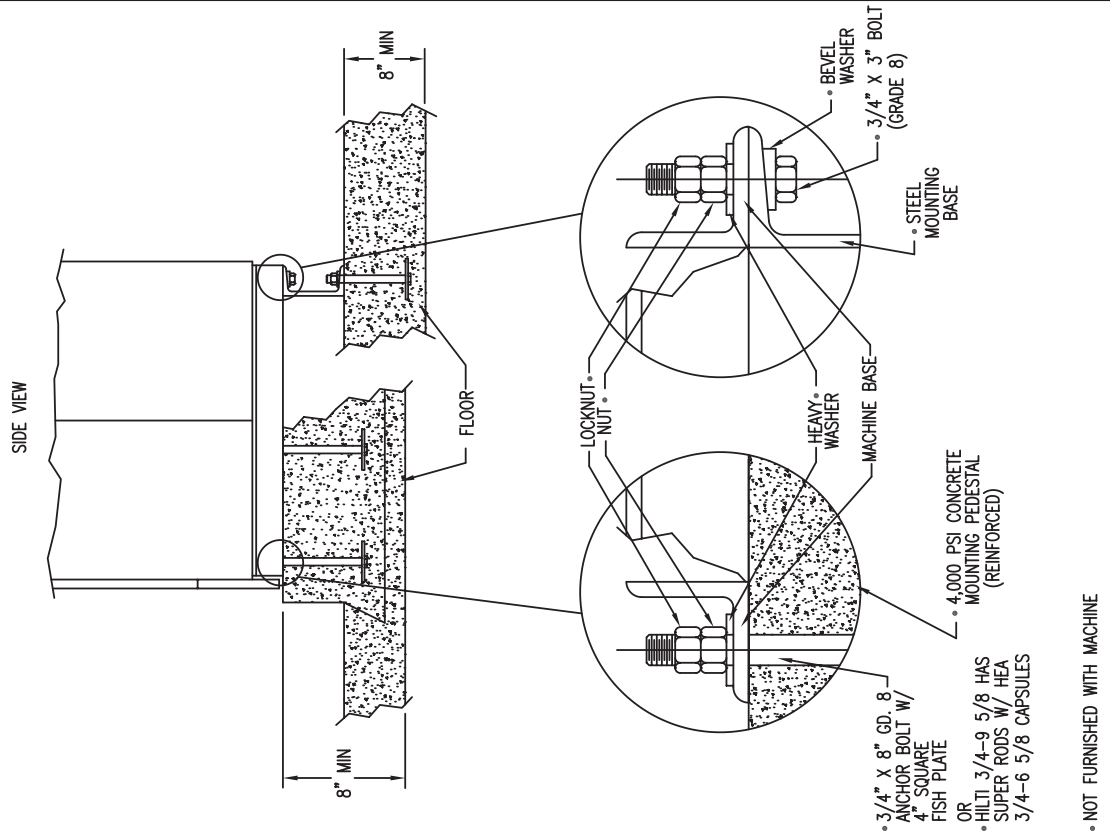

3/4" X 8" GD. 8 BOLTS
HEADED BY 4" SQ. FISH PLATE OR EQUIV.

OR

'HILTI' ADHESIVE ANCHORING SYSTEM.
USE HILTI 'HEA' 3/4-6 5/8 ADHESIVE CAPSULES
AND HILTI 'HAS' SUPER RODS 3/4-9 5/8
FOR MORE INFORMATION CALL
HILTI CUSTOMER SERVICE
1-800-879-8000

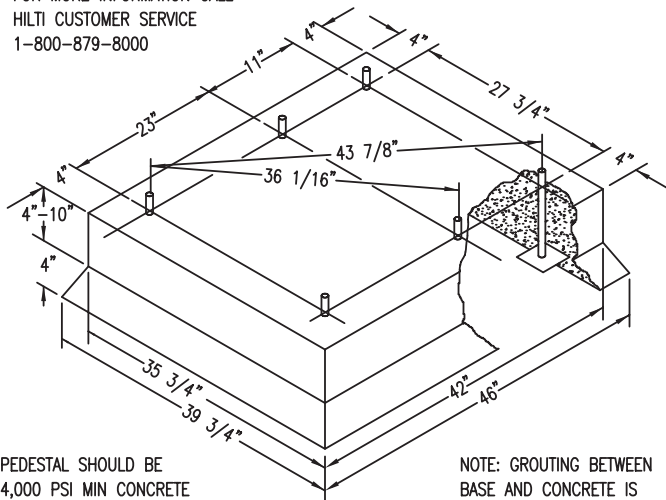

PEDESTAL SHOULD BE
4,000 PSI MIN CONCRETE
REINFORCED WITH
MESH OR RODS.

NOTE: GROUTING BETWEEN
BASE AND CONCRETE IS
REQUIRED.

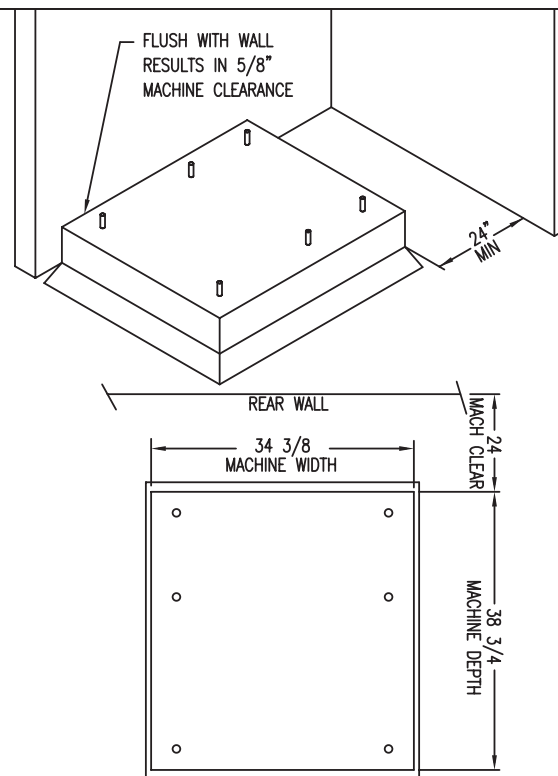

T-1200 Mounting Pad Dimensions

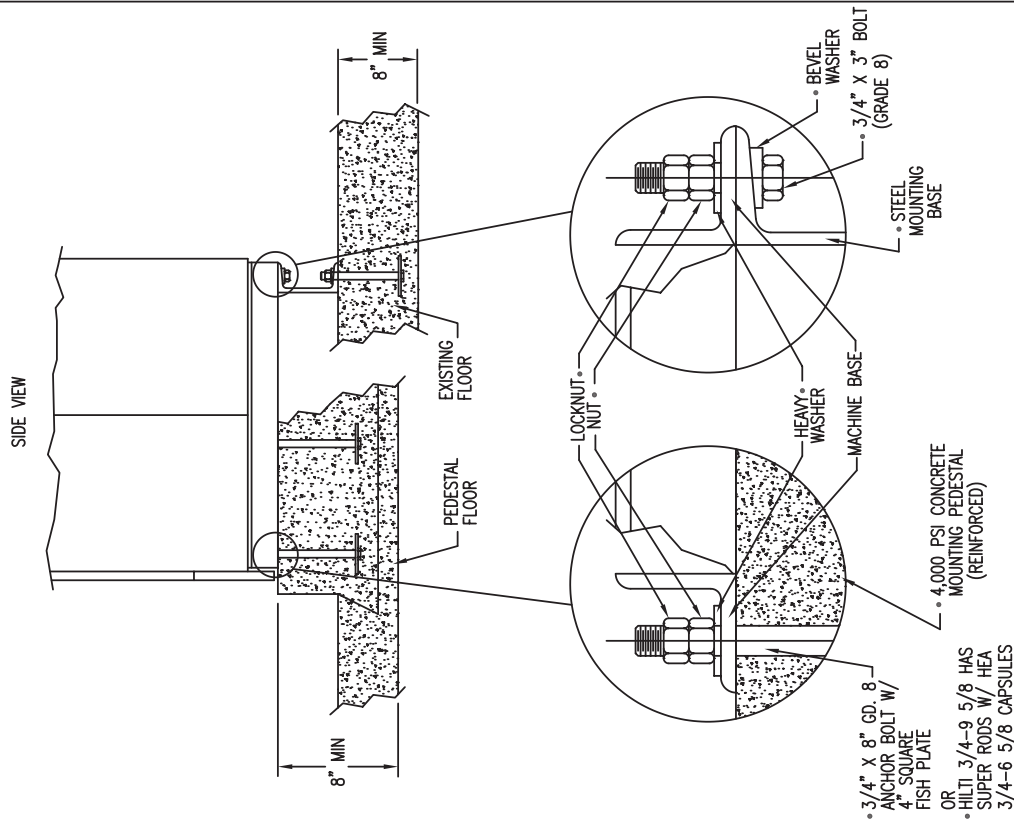

MACHINE MOUNTING DETAIL
Figure 1-3

3/4" X 8" GD. 8 BOLTS
HEADED BY 4" SQ. FISH PLATE OR EQUIV.
OR

'HILTI' ADHESIVE ANCHORING SYSTEM.
USE HILTI 'HEA' 3/4-6 5/8 ADHESIVE CAPSULES
AND HILTI 'HAS' SUPER RODS 3/4-9 5/8
FOR MORE INFORMATION CALL
HILTI CUSTOMER SERVICE
1-800-879-8000

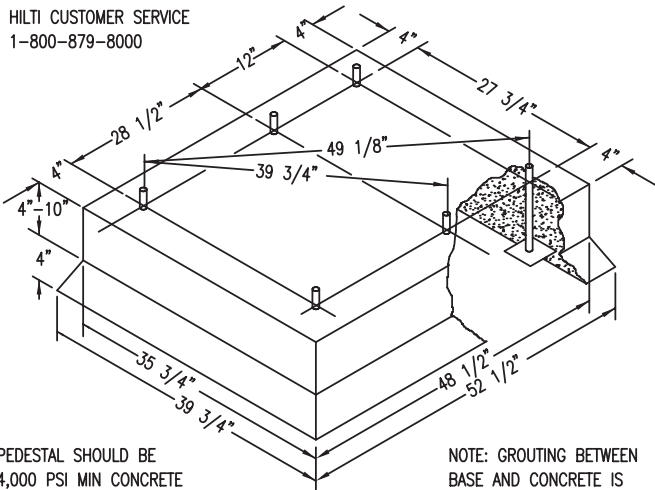

PEDESTAL SHOULD BE
4,000 PSI MIN CONCRETE
REINFORCED WITH
MESH OR RODS.

NOTE: GROUTING BETWEEN
BASE AND CONCRETE IS
REQUIRED.

CONCRETE PEDESTAL MOUNTING

Figure 1-1

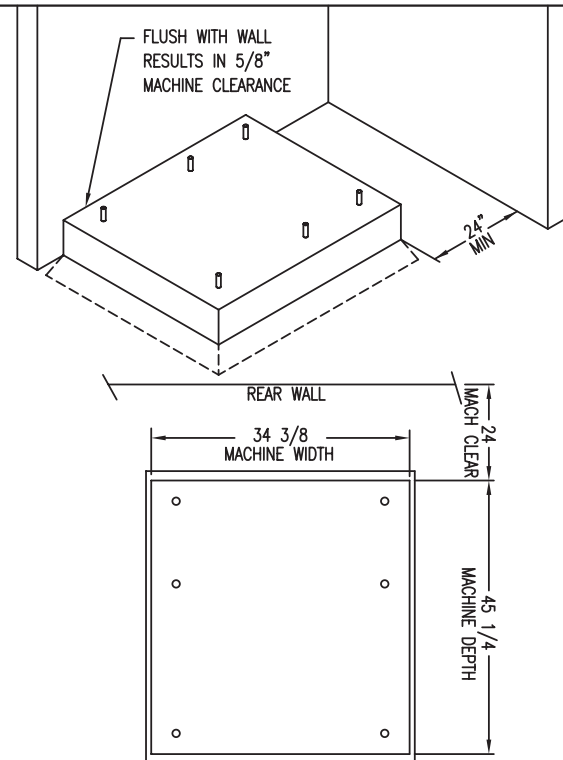

FLOOR OUTLINE

Figure 1-2

Section 2:

Machine
Installation
& Operating
Instructions

Installation & Operation

All washers must be installed in accordance with all local, state and national building, electrical, and plumbing codes in effect in the area.

Foundation Requirements

The washer must be securely bolted to a substantial concrete floor, or mounted upon a suitable base which is in turn securely bolted to a substantial concrete floor. Care must be stressed with all foundation work to insure a stable unit, eliminating vibration. All installations must be made on sound concrete floors. See mounting dimensions for each model being installed.

Mounting

A concrete pad or steel base which elevates the machine 4 to 6 inches above the floor level, to provide easy access to the loading door. It is recommended to allow a minimum of 24" of clearance behind the rear of the machine for service. Dexter highly recommends the use of a dry expansion grout mix.

Proper Machine Grout Installation

Grout should be installed between base (if used) and concrete floor on all side rails and crossmembers. If using a base you should grout between base top and machine frame and all side rails and crossmembers.

Mounting Holes

See mounting dimensions for the machine model you are installing in previous section. They also show a typical concrete pad arrangement. It is highly recommended that you use all mounting holes supplied with each model. Note: Mounting bolts should be checked frequently to insure that they remain tight. The machine should be checked with a spinning load to be sure there is no unusual vibration or movement between the machine and the base or floor. Please note: Machine grouting is highly recommended as grouting insures stability and longevity.

Plumbing

Water supply hoses are furnished with each machine. The threaded connections on the hoses are standard garden hose type thread. Separate hot and cold water lines with shut off valves or faucets for inlet hose connections must be provided, maintaining 30 to 120 p.s.i. water flow pressure. Maximum water temperature is 180 degrees fahrenheit.

Drain

The drain outlet tube at the rear of the machine is 3" in outside diameter on models T-600, T-900, T-1200. Adequate fall must be maintained for proper drainage.

Protective Film

The machine may have protective adhesive film on the front escutcheon area and the front and side stainless steel panels. The film may be peeled off before putting the machine into service.

Electrical

Dexter single/three-phase 208-240VAC 60 Hz washing machines are intended to be permanently installed appliances. No power cord is provided. The machine should be connected to an individual branch circuit not shared by lighting or other equipment. The connection should be sheathed in liquid tight flexible conduit, or equivalent, with conductors of the proper size and insulation. A qualified technician should make such connections in accordance with the wiring diagram.

A U.L. approved receptacle, which has been properly grounded in accordance with local electrical codes must be used with the machine. Each unit should be connected to an individual branch circuit not shared by lighting or other equipment. Conductors of the proper size and insulation (suggested size below) should be used.

To Make Electrical Connections

Disconnect all power to the washer. Remove screw and lift out the cover located in the upper left corner of the machine (as viewed from the back).

- If power is 208-240-3PH-60Hz, connect L1, L2, L3 and ground. If there is a high leg it must be connected to L3. It is highly recommended to use a TVSS.

- If power is 208-240-1PH-60Hz, connect L1, L2 and Ground.
Note: Use a UL approved receptacle with proper external ground.

NOTE: It is important that the grounding screw next to the power terminal block TB-1 be connected to a good external ground.

Controls Transformer

The controls transformer is located inside the control trough and steps a range of 208 to 240 volts down to 115 volts. There are two terminals on the controls transformer for the primary (incoming) power. Use the terminal marked "208V" for power supplies between 200 and 215 volts. Use the terminal marked "230V" for power supplies between 216 and 240 volts.

NOTE: L1 on the transformer must be set at proper tap for proper operation.

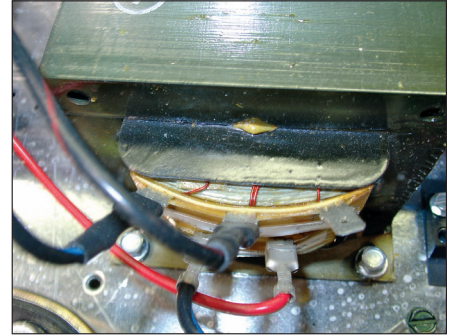

Electrical Connections

Electrical power connections are made to the small terminal block located in the rear of the machine. The terminal block is accessed by removing the access cover.

- 1 Phase or 3 Phase connections
- 208-240 volts, 60 Hz.
- 2 or 3 wire plus ground
- Suggested Minimum Wire Size -- 12 Ga.

Fusing Requirements:

Dual element time delay fuse or equivalent breaker of amperage specified below.

- 1 Phase or 3 Phase 15 amp
- T-600

- 1 Phase or 3 Phase 20 amp
- T-900 or T-1200

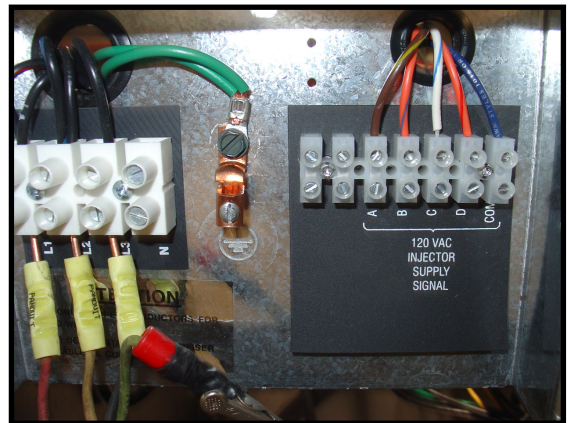

Rotation in extract as viewed through glass door at front of washer models will be counter-clockwise



WARNING

Always disconnect electrical power to the machine before performing any adjustments or service.

Liquid Chemical Connection

L1
L2
L3
N (not needed)

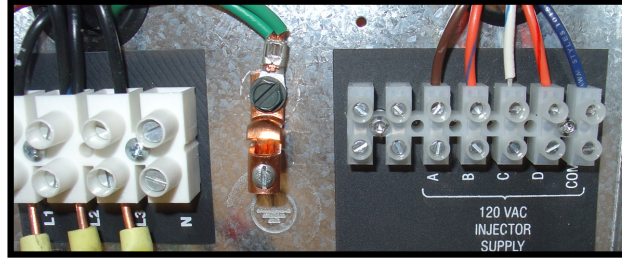

A
B
C
D
Common

**208/240 VAC
Power Connections**

**Ground
Connection**

**120VAC Injector
Supply Connections
Power Connections**

In the right rear corner of the washer is the chemical injection assembly. This is where all chemical hose connections are made. The chemical hoses should be inserted into the round pvc pipe a minimum of 14" and a maximum of 18" to eliminate chemical buildup in the pipe and/or restrict water flow to the tub.

Chemical Injection Signals added in programming section.

- #0-No Signal
- #1-A terminal
- #2-B terminal
- #3-C terminal
- #4-D terminal
- #5-A & B
- #6-C & D
- Com-120VAC common

Injection Source Details

The washer control may be programmed to send output signals for a chemical injection system. There is a separate terminal block for connection of the external injection signals. For the injection sources, program codes 0 through 6 are as shown in the table below. Injection signal will trigger a 120 volt reading at rear terminal block for approximately 5-10 seconds and will start to trigger at about 10-15 seconds after start of fill bath.



**Dexter Recommended
Connections**

**Controller Programmed
Signals**

**Injection Terminal
Block Connection**

Detergent	1	A
Bleach	2	B
Starch	3	C
Sour/Softener	4	D
	5	A and B
	6	C and D
	0	None

Note : The Wash Cycle programming mode will automatically exit and return to the Idle mode if no buttons are pushed for one minute.

Operating Instructions

There are four (4) switches that control the washer operation. Each switch is shown below followed by an explanation of each switch.

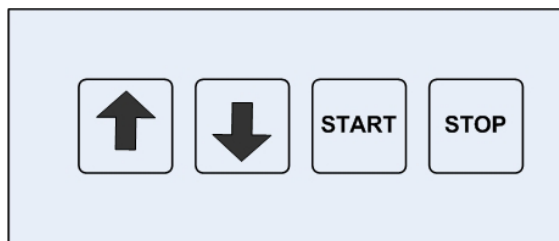

Push-button Control Switches

STOP (RED) Push-button

Depress momentarily - Stops the washer during the cycle. All washer cycle information is retained, the door remains locked, and the water remains in the tub.

Depress and hold for 3 seconds or longer- Stops the washer and clears the cycle. All washer cycle information is cleared, the water is drained, and the door is unlocked. The washer is ready for the next wash cycle.

Note: The door lock safety mechanism will prevent the door from opening for up to 3 minutes when the washer is stopped during a cycle, and the cycle cleared.

WARNING: DEPRESSING AND HOLDING THE STOP BUTTON.THIS DOES NOT DISCONNECT THE MACHINE FROM THE INPUT POWER.

START (GREEN) Push-button

Depress momentarily -Starts the cycle shown on the display. If the cycle was stopped in the middle, depressing the START will begin the cycle, from the point at which the cycle was stopped.

SCROLL UP ARROW (BLUE) Push-button

Depress momentarily / depress and hold - increases the cycle number displayed by one each time the switch is depressed. When the Scroll Up is held, the display cycle numbers will continue to increase until cycle #30 (cycle #31 in Programming Mode) is reached, at which time the cycle number displayed will rollover back to cycle #1.

SCROLL DOWN ARROW (BLUE) Push-button

Depress momentarily / depress and hold- Scroll Down decreases the cycle number displayed by one each time the switch is depressed. When the Scroll Up is held, the display cycle numbers will continue to decrease until cycle #1 is reached at which time the cycle number displayed will rollover to cycle #30 (cycle #31 in Programming Mode).

Operating Instructions

1. Ensure that power is turned on to the washer.
2. Ensure that the **ADVANCE/RUN/PROGRAM** key lock is in the RUN position.
3. Load the clothes loosely in the cylinder and latch the door securely. Be sure clothing does not get caught between the door gasket and tub front when closing the door.

NOTE: To begin closing the door, the handle must be in the horizontal position. After moving the door to the closed position, the handle must be turned down to the vertical position in order to latch the door for machine operation.

4. Select one of the thirty cycles, by using the **SCROLL UP/SCROLL DOWN** buttons to change the number indicated in the two digit LED display. The selection is made when the number indicated corresponds with the desired cycle.
5. If you are manually adding wash compounds, add low sudsing powdered detergent in the amount shown below into the detergent compartment on top of the machine or in front soap compartment.
Location is illustrated on the black cover on the top of the machine. This compartment will be flushed during the WASH segment of the cycle. Rinse conditioners may be added to their own compartment if desired. This compartment will be flushed during the FINAL RINSE segment of the cycle.
6. If you wish to manually add bleach during the cycle, add bleach in the round opening in the top of the machine. Location is illustrated on the black cover on the top of the machine.

NOTE: Any additional washing compounds may be added at the appropriate time by pouring into the round opening in the top.

7. Push the green **START** button to start the cycle.
8. The cycle time remaining is displayed throughout the cycle. The cycle number in operation can be displayed by pushing and holding **START**, then push **SCROLL UP**. The cycle number will be displayed as long as these two buttons are depressed.
The actual bath temperature can be displayed by simultaneously pushing the **START** and **SCROLL DOWN** button.

Soak - At any time during the cycle, the red **STOP** button can be depressed to stop the washer timer from counting down. All washer cycle information is retained and the door remains locked. The washer will soak the load for 15 minutes, then agitate for 30 seconds. This will repeat until the cycle is started again. This feature allows for an extended soak if required. The washer cycle will continue when the **START** button is depressed.

NOTE: The selected cycle can be cleared at any time by depressing and holding the **STOP** button for a minimum of three seconds.

End of Cycle

At the end of the cycle the machine stops, the **END CYCLE LED** lights, the alarm sounds, and the loading door unlocks allowing unloading of the machine.

Safety Door Lock

This machine is equipped with a Safety Door Lock which prevents opening the door if power is interrupted, until it is safe to do so.

If power failure occurs, it will be necessary to wait 2 to 3 minutes before the door can be opened.

Motor Drive indicators

There is a five digit, seven segment, display on the drive which can be viewed by removing the access cover at the top rear of the washer. There are also small L.E.D.s on the left and bottom edge of the display that can be viewed and used for troubleshooting. The five seven segment digits will change value depending on where the washer is during the wash cycle.

Computer Control Indicators

Computer control OPL machine has 30 different selectable cycles; 29 of the 30 cycles are preset with the most common industry applications. See the Preset Cycle Information sheets for complete cycle information. If these cycle settings do not meet the required application, each cycle is re-programmable by the user, simply and reliably.

Each cycle has up to 9 baths which are Flush, Pre-wash, Wash, Rinse 1, 2, 3, 4, 5 and Final Rinse/Extract. There are five user selectable settings within each bath to allow cycle tailoring to meet exact applications. The settings and the limits of each are shown in the table below. The Scroll Up/Scroll Down buttons are used to change the settings.

Bath Setting Limits

Cycle Time - 0 to 30 minutes (1 minute increments)

The Cycle time (tumble) settings are 0 minutes to 30 minutes in 1 minute increments for each bath. If the setting is 0, then that bath is skipped over. For the Final Rinse /Extract bath, the minimum time must be 1 minute.

Water Temperature - Hot, Warm, Cold, Empty, (20-90C if heated model)

The water temperature setting is displayed as HH = hot, CH = warm, CC = cold, EE = No water bath, 20-90C in 5 degrees increments. When the No Water or EE bath is selected, the water level can be set to either high or low and NO Injection will be made even if the injection source is programmed. Maximum temperature for final rinse is 60 C.

Water Level - High or Low

The water level setting is displayed as HI for high level and LO for low level.

Injection Source 0 to 6

The injection source settings are 0 through 6 with 0 being no injection and settings 1 through 6 relating to an injection source. See Recommended Injection Table.

Spin Time - 0 to 10 minutes (1 minute increments)

The spin time settings are 0 minutes to 10 minutes in 1 minute increments. If the setting is 0, there is no spin for the bath. Final Rinse/Extract minimum setting is 1 minute.

TRANSIENT VOLTAGE SURGE SUPPRESSORS

Like most electrical equipment your new machine can be damaged or have its life shortened by voltage surges due to lightning strikes which are not covered by factory warranty. Local power distribution problems also can be detrimental to the life of electrical components. We recommend the installation of transient voltage surge suppressors for your new equipment. These devices may be placed at the power supply panel for the complete installation and don't require an individual device for each machine.

These surge protectors help to protect equipment from large spikes and also from small ongoing spikes in the power that occur on a day to day basis. These smaller surges can shorten overall life of electrical components of all types and cause their failure at a later date. Although they can't protect against all events, these protective devices have a good reputation for significantly lengthening the useful life of electronic components.

Electronic Components are helped to have a longer useful life when they are supplied with the clean stable electrical power they like.

We are including the following names and links to a few suppliers of these devices for those who don't currently have a source.

MANUFACTURER	LINK
MCG Surge Protection	mcgsurge.com
Eaton Corporation	eaton.com/us/en-us
Schneider Electric	se.com/us/en
Asco Power Technologies	ascopower.com/us/en
Emerson Electric Co.	emerson.com/en-us

Section 3:

Machine
Programming
Instructions

Programming Instructions

Editing an Existing Cycle

There are 29 preset wash cycles programmed into the washer at the factory. Although these cycles are common industry cycles, there may be a need to tailor the cycle to meet an exact application. This can easily be done with the following instructions. **Note:** It is recommended when changes are made to one or more of the preset programs that the cycle number and the changes be documented for later reference. Blank cycle sheets have been provided at the end of the Preset Cycle Information section.

- 1. Turn on the power to the washer.**
- 2. Turn the Advance/Run/Program key to the Program position (Program Mode LED lights).**
The Select Cycle LED is lit.
- 3. Select the cycle to be edited by using the SCROLL UP/SCROLL DOWN buttons.**
The selection is made when the number displayed corresponds with the desired cycle.
- 4. Push the green ENTER button.**
Once depressed, the first of the nine cycle segment LED's will light (top row). The cycle segments are: Flush, Pre-wash, Wash, Rinse 1, Rinse 2, Rinse 3, Rinse 4, Rinse 5 and Final Rinse/Extract. The Select Cycle LED is out.
- 5. Use the SCROLL UP / SCROLL DOWN buttons to light the cycle segment to be changed.**

The sequence of steps below is repeated for each cycle segment until all required segments are edited. The previously stored parameters will appear as each part of the segment data is reviewed.

- 6. Push the green ENTER button.**
The Cycle Time LED lights (lower row of LED's) and the segment LED is out. The tumble time for this segment will be shown on the display. If no change is required, then continue to the next instruction. If this value requires changing, then use the **SCROLL UP/SCROLL DOWN** buttons to change the tumble time, in 1 minute increments, to the desired value, then continue to the next instruction. Settings range is from 0 minutes to 30 minutes, except for the Final Rinse/Extract segment, where the setting range is 1 minute to 30 minutes. **REMINDER:** If the tumble time is set to zero, the segment will be skipped in the wash cycle.
- 7. Push the green ENTER button. (The wash time has now been entered.)**
The Water Temperature LED lights and the Cycle Time LED is out. The water temperature for this segment is displayed. If no change is required, then continue to the next instruction. If a change is required, then use the **SCROLL UP/SCROLL DOWN** buttons to change the water temperature. HH is all hot water, CC is all cold water, CH is an even mix of hot and cold water, and EE is a no water bath. Entering a temperature value of 20-90 C will result in a heated bath, if temperature of fill water is less than programmed temperature. When the desired water temperature is selected, continue to the next instruction.
- 8. Push the green ENTER button. (The water temperature has now been entered.)**
The Water Level LED lights and the Water Temperature LED is out. The water level for this segment is displayed. If no change is required, then continue to the next instruction. If a change is required, then use the **SCROLL UP/SCROLL DOWN** buttons to change the water level. "HI" is a high water level and "LO" is a low water level. When the desired water level is selected, continue to the next instruction. When the No Water bath is selected, the water level has no effect. Either water level can be selected.
- 9. Push the green ENTER button. (The water level has now been entered.)**
The Injection Source LED lights and the Water Level LED is out. The injection source for this segment is displayed. If no change is required, then continue to the next instruction. If a change is required,

then use the **SCROLL UP/SCROLL DOWN** buttons to change the injection source. See the Injection Source table for proper selection. If zero is selected, then no injection source is active for this segment. When the desired injection source is selected, continue to the next instruction. When the No Water or EE bath is selected, injection signals are prohibited by the electronic controller. The programmed injection source value is ignored.

10. Push the green ENTER button. (The injection source has now been entered.)

The Spin Time LED lights and the Injection Source LED is out. The spin time for this segment is displayed. If no change is required, then continue to the next instruction. If this value requires changing, then use the **SCROLL UP/SCROLL DOWN** buttons to change the spin time in 1 minute increments to the desired value, then continue to the next instruction. Settings range is from 0 minutes to 10 minutes, except for the Final Rinse/Extract segment where the setting range is 1 minute to 10 minutes. **REMINDER:** If the spin time is set to zero, there will be no spin at the end of the bath.

11. Push the green ENTER button. (The extract time has now been entered.)

Once depressed, the Spin Time LED is out and the editing of one segment is complete. The next sequential cycle segment LED lights, unless the segment edited above was the Final Rinse/Extract segment. If the Final Rinse/Extract segment is edited, after step eleven, the cycle programming is complete, and the machine will return to the Programming Mode awaiting a cycle select (Step 3).

To exit the programming mode, depress the red STOP button when one of the nine cycle segment LED lights are lit. The programming changes made prior to the program exit are retained and the cycle is updated.

Cycle Times

	Cycles 1-30	Chemical Signal	Water Level	Water Temp
Flush	0-30 min.	1-6	High or low	Hot, Cold, Warm or Empty
Drain	40 sec.			
Int. Spin	0-10 min.			
Prewash	0-30 min.	1-6	High or low	Hot, Cold, Warm or Empty
Drain	40 sec.			
Int. Spin	0-10 min.			
Wash	0-30 min.	1-6	High or low	Hot, Cold, Warm or Empty
Drain	40 sec.			
Int. Spin	0-10 min.			
Rinse 1	0-30 min.	1-6	High or low	Hot, Cold, Warm or Empty
Drain	40 sec.			
Int. Spin	0-10 min.			
Rinse 2	0-30 min.	1-6	High or low	Hot, Cold, Warm or Empty
Drain	40 sec.			
Int. Spin	0-10 min.			
Rinse 3	0-30 min.	1-6	High or low	Hot, Cold, Warm or Empty
Drain	40 sec.			
Int. Spin	0-10 min.			
Rinse 4	0-30 min.	1-6	High or low	Hot, Cold, Warm or Empty
Drain	40 sec.			
Int. Spin	0-10 min.			
Rinse 5	0-30 min.	1-6	High or low	Hot, Cold, Warm or Empty
Drain	40 sec.			
Extract	1-10 min.			
Total *	1-320 min.			

* Cycle times are approximate and do not include fill time from empty to low level.

* Fill time from low to high level is included as computer operates during this period.

30 Preset Wash Cycles

All wash cycles can be reprogrammed (see Section 2)

Application Cycle # Description

Shirt/Laundry

- 1 Shirts (No Starch)
- 2 Shirts (Starch)

Hotel/Motel

- 3 White Sheets
- 4 White Pillowcases
- 5 White Towels, Bath Mats, Wash Cloths
- 6 Colored Sheets and Towels
- 7 Delicate Wash
- 8 Housekeeping Rags and Mops
- 9 Housekeeping Uniforms
- 10 Stain Treatment
- 11 Reclaim Part 1
- 12 Reclaim Part 2

Health Care

- 13 Sheets and Pillowcases
- 14 Towels
- 15 Diapers and Pads
- 16 Personals
- 17 Delicate

Food & Beverage

- 18 White (Cotton/Blend) Table Linen
- 19 Colored (Cotton/Blend) Table Linen
- 20 White 100% Polyester Table Linen
- 21 Colored 100% Polyester Table Linen
- 22 White Chef Coats
- 23 Kitchen and Maintenance Rags
- 24 White/Colored (Cotton/Blend) Table Linen
- 25 White/Colored 100% Polyester Table Linen
- 26 White Chef Coats
- 27 Kitchen and Maintenance Rags

Other

- 28 Oxygen Bleach - Terry
- 29 Oxygen Bleach - Terry (No iron)

Test

- 30 Test Injection Signals and Pressure Switch
- 31 **Test Diagnostic**

CYCLE 1 Shirt/Laundry Shirts (No Starch)

Cycle Segment	Time	Water Temp	Water Level	Inject Source	Spin Time
Flush					
Pre-wash					
Wash	12	HH	LO	Detergent/Bleach	1
Rinse 1	2	CH	HI		
Rinse 2	2	CH	HI		
Rinse 3	2	CH	HI		
Rinse 4					
Rinse 5					
Final	4	CH	LO		3

CYCLE 2 Shirt/Laundry Shirts (Starch)

Segment	Cycle Time	Water Temp	Water Level	Inject Source	Spin Time
Flush					
Pre-wash					
Wash	12	HH	LO	Detergent/Bleach	
Rinse 1	2	CH	HI		
Rinse 2	2	CH	HI		
Rinse 3	2	CH	HI		
Rinse 4					
Rinse 5					
Final	7	CH	LO	Starch	3

CYCLE 3 Hotel/Motel White Sheets

Segment	Cycle Time	Water Temp	Water Level	Inject Source	Spin Time
Flush					
Pre-wash	7	HH	LO	Detergent	
Wash	7	HH	LO	Bleach	
Rinse 1	2	CH	HI		1
Rinse 2	2	CH	HI		
Rinse 3					
Rinse 4					
Rinse 5					
Final	4	CH	LO	Sour/Soft	4

CYCLE 4 Hotel/Motel White Pillowcases

Segment	Cycle Time	Water Temp	Water Level	Inject Source	Spin Time
Flush	7	HH	LO	Detergent	
Pre-wash	1	HH	HI		
Wash	7	HH	LO	Bleach	
Rinse 1	2	CH	HI		1
Rinse 2	2	CH	HI		
Rinse 3					
Rinse 4					
Rinse 5					
Final	4	CH	LO	Sour/Soft	4

CYCLE 5 Hotel/Motel White Towels

Segment	Cycle Time	Water Temp	Water Level	Inject Source	Spin Time
Flush	7	HH	LO	Detergent	
Pre-wash	1	HH	HI		
Wash	7	HH	LO	Bleach	
Rinse 1	2	CH	HI		1
Rinse 2	2	CH	HI		
Rinse 3					
Rinse 4					
Rinse 5					
Final	4	CH	LO	Sour/Soft	5

CYCLE 6 Hotel/Motel Color Sheets

Segment	Cycle Time	Water Temp	Water Level	Inject Source	Spin Time
Flush					
Pre-wash					
Wash	7	HH	LO	Detergent/Bleach	
Rinse 1	2	HH	HI		
Rinse 2	2	CH	HI		1
Rinse 3	2	CH	HI		
Rinse 4					
Rinse 5					
Final	4	CH	LO	Sour/Soft	4

CYCLE 7 Hotel/Motel Delicate

Segment	Cycle Time	Water Temp	Water Level	Inject Source	Spin Time
Flush					
Pre-wash					
Wash	8	CH	HI	Detergent/Bleach	
Rinse 1	2	HH	HI		
Rinse 2	2	CH	HI		
Rinse 3	2	CH	HI		
Rinse 4					
Rinse 5					
Final	4	CH	LO	Sour/Soft	4

CYCLE 8 Hotel/Motel Rags and Mops

Segment	Cycle Time	Water Temp	Water Level	Inject Source	Spin Time
Flush	3	CH	HI		
Pre-wash	2	CH	HI		
Wash	2	CH	HI		
Rinse 1	2	CH	HI		
Rinse 2	7	HH	LO	Detergent	
Rinse 3	2	HH	HI		
Rinse 4	7	HH	LO	Bleach	
Rinse 5	2	CH	HI		1
Final	2	CH	HI		5

CYCLE 9 Hotel/Motel Uniforms

Segment	Cycle Time	Water Temp	Water Level	Inject Source	Spin Time
Flush	2	CH	HI		
Pre-wash					
Wash	7	HH	LO	Detergent	
Rinse 1	7	HH	LO	Bleach	
Rinse 2	2	CH	HI		1
Rinse 3	2	CH	HI		
Rinse 4					
Rinse 5					
Final	4	CH	LO	Sour/Soft	4

CYCLE 10 Hotel/Motel Stain Treatment - Chlorine Bleach

Segment	Cycle Time	Water Temp	Water Level	Inject Source	Spin Time
Flush					
Pre-wash					
Wash	30	HH	LO	Detergent/Bleach	
Rinse 1	2	HH	HI		
Rinse 2	2	HH	HI		
Rinse 3	2	CH	HI		1
Rinse 4					
Rinse 5					
Final	2	CH	HI		4

CYCLE 11 Hotel/Motel Reclaim (Part 1)

Segment	Cycle Time	Water Temp	Water Level	Inject Source	Spin Time
Flush					
Pre-wash					
Wash	20	HH	LO	Manual	
Rinse 1	3	HH	HI		
Rinse 2					
Rinse 3					
Rinse 4					
Rinse 5					
Final	3	HH	HI		1

CYCLE 12 - Hotel/Motel / Reclaim (Part 2)

Segment	Cycle Time	Water Temp	Water Level	Inject Source	Spin Time
Flush					
Pre-wash	3	HH	HI		
Wash	20	HH	LO	Manual	
Rinse 1	3	HH	HI		
Rinse 2	3	HH	HI		
Rinse 3	10	HH	LO	Bleach	
Rinse 4	3	HH	HI		1
Rinse 5					
Final	3	CH	HI		4

CYCLE 13 - Health Care / Sheets and Pillowcases

Segment	Cycle Time	Water Temp	Water Level	Inject Source	Spin Time
Flush	3	CH	HI		
Pre-wash	2	CH	HI		
Wash	7	HH	LO	Detergent	
Rinse 1	7	HH	LO	Bleach	
Rinse 2	2	CH	HI		1
Rinse 3	2	CH	HI		
Rinse 4					
Rinse 5					
Final	4	CH	LO	Sour/Soft	4

CYCLE 14 - Health Care / Towels

Segment	Cycle Time	Water Temp	Water Level	Inject Source	Spin Time
Flush	3	CH	HI		
Pre-wash	2	CH	HI		
Wash	7	HH	LO	Detergent	
Rinse 1	1	HH	HI		
Rinse 2	7	HH	LO	Bleach	
Rinse 3	2	CH	HI		1
Rinse 4	2	CH	HI		
Rinse 5					
Final	4	CH	LO	Sour/Soft	5

CYCLE 15 Health Care / Diapers

Segment	Cycle Time	Water Temp	Water Level	Inject Source	Spin Time
Flush	3	CH	HI		
Pre-wash	2	CH	HI		
Wash	2	CH	HI		
Rinse 1	7	HH	LO	Detergent	
Rinse 2	2	HH	HI		
Rinse 3	7	HH	LO	Bleach	
Rinse 4	2	CH	HI		1
Rinse 5	2	CH	HI		
Final	4	CH	LO	Sour/Soft	4

CYCLE 16 - Health Care / Personals

Segment	Cycle Time	Water Temp	Water Level	Inject Source	Spin Time
Flush	3	CH	HI		
Pre-wash					
Wash	7	HH	LO	Detergent/Bleach	
Rinse 1	2	HH	HI		
Rinse 2	2	CH	HI		
Rinse 3	2	CH	HI		
Rinse 4					
Rinse 5					
Final	4	CH	LO	Sour/Soft	4

CYCLE 17 - Health Care / Delicate

Segment	Cycle Time	Water Temp	Water Level	Inject Source	Spin Time
Flush	2	CH	HI		
Pre-wash					
Wash	7	CH	HI	Detergent/Bleach	
Rinse 1	2	CH	HI		
Rinse 2	2	CH	HI		
Rinse 3	2	CH	HI		
Rinse 4					
Rinse 5					
Final	4	CH	HI	Sour/Soft	3

CYCLE 18 - Food and Beverage / White Cotton Linen

Segment	Cycle Time	Water Temp	Water Level	Inject Source	Spin Time
Flush	2	CH	HI		
Pre-wash					
Wash	10	HH	LO	Detergent	
Rinse 1	2	HH	HI		
Rinse 2	7	HH	LO	Bleach	
Rinse 3	2	CH	HI		1
Rinse 4	2	CH	HI		
Rinse 5					
Final	4	CH	LO	Sour/Starch	4

CYCLE 19 - Food and Beverage / Colored Cotton Linen

Segment	Cycle Time	Water Temp	Water Level	Inject Source	Spin Time
Flush	2	CH	HI		
Pre-wash					
Wash	10	HH	LO	Detergent	
Rinse 1	7	HH	LO	Bleach	
Rinse 2	2	CH	HI		1
Rinse 3	2	CH	HI		
Rinse 4					
Rinse 5					
Final	4	CH	LO	Sour/Starch	4

CYCLE 20 - Food and Beverage / White 100% Polyester Linen

Segment	Cycle Time	Water Temp	Water Level	Inject Source	Spin Time
Flush	2	CH	HI		
Pre-wash					
Wash	10	HH	LO	Detergent	
Rinse 1	2	HH	HI		
Rinse 2	7	HH	LO	Bleach	
Rinse 3	2	CH	HI		1
Rinse 4	2	CH	HI		
Rinse 5					
Final	4	CH	LO	Sour/Starch	4

CYCLE 21 Food and Beverage / Colored 100% Polyester Linen

Segment	Cycle Time	Water Temp	Water Level	Inject Source	Spin Time
Flush	2	CH	HI		
Pre-wash					
Wash	10	HH	LO	Detergent	
Rinse 1	7	HH	LO	Bleach	
Rinse 2	2	CH	HI		1
Rinse 3	2	CH	HI		
Rinse 4					
Rinse 5					
Final	4	CH	LO	Sour/Starch	4

CYCLE 22 - Food and Beverage / White Chef Coats

Segment	Cycle Time	Water Temp	Water Level	Inject Source	Spin Time
Flush	5	HH	LO	Detergent	
Pre-wash	1	HH	HI		
Wash	8	HH	LO	Detergent	
Rinse 1	2	HH	HI		
Rinse 2	7	HH	LO	Bleach	
Rinse 3	2	CH	HI		1
Rinse 4	2	CH	H		
Rinse 5					
Final	4	CH	LO	Sour	4

CYCLE 23 - Food and Beverage / Kitchen Rags

Segment	Cycle Time	Water Temp	Water Level	Inject Source	Spin Time
Flush	5	HH	LO	Detergent	
Pre-wash	2	HH	HI		
Wash	8	HH	LO	Detergent	
Rinse 1	2	HH	HI		1
Rinse 2	7	HH	LO	Bleach	
Rinse 3	2	CH	HI		1
Rinse 4					
Rinse 5					
Final	2	CH	HI		5

CYCLE 24-Food and Beverage/White & Colors(Cotton/Blend) Linen

Segment	Cycle Time	Water Temp	Water Level	Inject Source	Spin Time
Flush	2	CH	HI		
Pre-wash					
Wash	10	HH	LO	Detergent/Bleach	
Rinse 1	1	HH	HI		
Rinse 2	2	HH	HI		1
Rinse 3	2	CH	HI		
Rinse 4	2	CH	HI		
Rinse 5					
Final	4	CH	LO	Sour/Starch	4

CYCLE 25-Food and Beverage/White/Colors 100% Polyester Linen

Segment	Cycle Time	Water Temp	Water Level	Inject Source	Spin Time
Flush	2	CH	HI		
Pre-wash					
Wash	10	HH	LO	Detergent/Bleach	
Rinse 1	1	HH	HI		
Rinse 2	2	HH	LO		
Rinse 3	2	CH	HI		
Rinse 4	2	CH	HI		
Rinse 5					
Final	4	CH	LO	Sour/Starch	4

CYCLE 26 - Food and Beverage/ White Chef Coats

Segment	Cycle Time	Water Temp	Water Level	Inject Source	Spin Time
Flush	5	HH	LO	Detergent	
Pre-wash	1	HH	HI		
Wash	10	HH	LO	Detergent/Bleach	
Rinse 1	2	HH	HI		
Rinse 2	2	CH	HI		1
Rinse 3	2	CH	HI		
Rinse 4					
Rinse 5					
Final	4	CH	HI	Sour/Soft	4

CYCLE 27 - Food and Beverage / Kitchen Rags

Segment	Cycle Time	Water Temp	Water Level	Inject Source	Spin Time
Flush	5	HH	LO	Detergent	
Pre-wash	2	HH	HI		
Wash	10	HH	LO	Detergent/Bleach	
Rinse 1	1	HH	HI		
Rinse 2	2	HH	HI		1
Rinse 3	2	CH	HI		
Rinse 4					
Rinse 5					
Final	2	CH	HI		5

CYCLE 28 - Other/ Oxygen Bleach Terry

Segment	Cycle Time	Water Temp	Water Level	Inject Source	Spin Time
Flush	3	CH	HI		
Pre-wash	2	CH	HI		
Wash	10	HH	LO	Detergent/Bleach	
Rinse 1	2	HH	HI		
Rinse 2	2	CH	HI		1
Rinse 3	2	CH	HI		
Rinse 4					
Rinse 5					
Final	4	CH	LO	Sour/Soft	3

CYCLE 29 - Other/ Oxygen Bleach Terry (No Iron)

Segment	Cycle Time	Water Temp	Water Level	Inject Source	Spin Time
Flush	3	CH	HI		
Pre-wash	2	CH	HI		
Wash	10	HH	LO	Detergent/Bleach	
Rinse 1	2	HH	HI		
Rinse 2	2	CH	HI		1
Rinse 3	2	CH	HI		
Rinse 4					
Rinse 5					
Final	4	CH	LO	Sour/Soft	5

CYCLE 30 - Test Pressure Switch and Injection Signals

Segment	Cycle Time	Water Temp	Water Level	Inject Source	Spin Time
Flush	1	HH	LO	Detergent/Bleach	1
Pre-wash					
Wash					
Rinse 1					
Rinse 2					
Rinse 3					
Rinse 4					
Rinse 5					
Final	1	CC	HI	Sour/Starc	

2.11.5 MAXIMUM SPIN SPEED ADJUSTMENT (All washers except T-950)

If desired, the washer can be adjusted to limit the maximum extract spin speed for all wash cycles.

To make this adjustment, a jumper wire must either be installed or removed on the Variable Frequency Drive (VFD), depending on the washer model and desired speed. This Dexter jumper part number 8220-057-036 (qty 1) is factory supplied on terminal points "10V" and "RC". Remove this jumper to make new jumper connections if necessary. Refer to figure below for the approximate location of the control terminations on the Variable Frequency Drive (VFD) and for appropriate jumper connection points indicated with an "X" for the desired maximum spin speed setting. If no adjustment to the default spin speed is desired, do not remove or add any wires on VFD.

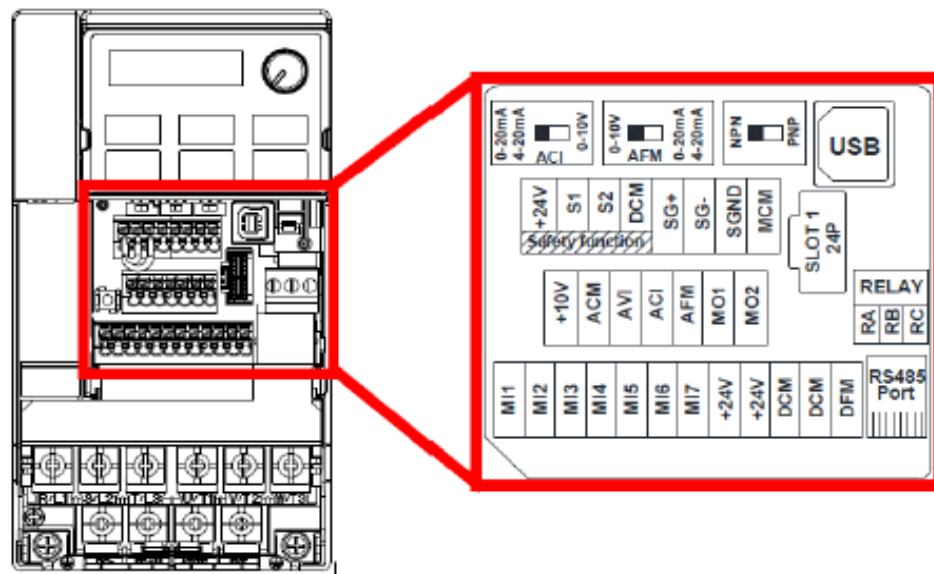

Control Terminations on Variable Frequency Drive

V Series Washer Model	Max Spin Speed	Jumper Terminal Locations on Variable Frequency Drive (VFD)													
		MI1	MI2	MI3	MI4	MI5	MI6	DCM (Left)	DCM (Right)	24V	ACM	AVI	ACI	10V	MO1
T-300, T-400, T-600, T-900, T-1200	60 G												X		X
	80 G				X			X							
	100 G	Default Setting (No Jumper Required)													
T-350, T-450, T-750	60 G												X		X
	100 G				X			X							
	140 G					X		X							
	200 G	Default Setting (No Jumper Required)													
T-650, T-1450	100 G												X		X
	140 G	REMOVE Brown Jumper Between MI5/MO1													
	200 G	Default Setting (No Jumper Required)													

Spin Speed Adjustment Jumper Locations

MAXIMUM SPIN SPEED ADJUSTMENT (T-950 Only)

The variable frequency drive allows for varying acceleration during Final Spin on T-950 models. It is important to utilize a decreased acceleration rate when the application power is low. This acceleration rate is determined by a white wire jumper installed on the drive terminal block from +10V to AVI.

Remove the wire jumper when input power is between 208 and 219 volts. Keep the jumper installed when input power is between 220 and 240 volts. Reference the drawing below for the jumper location.

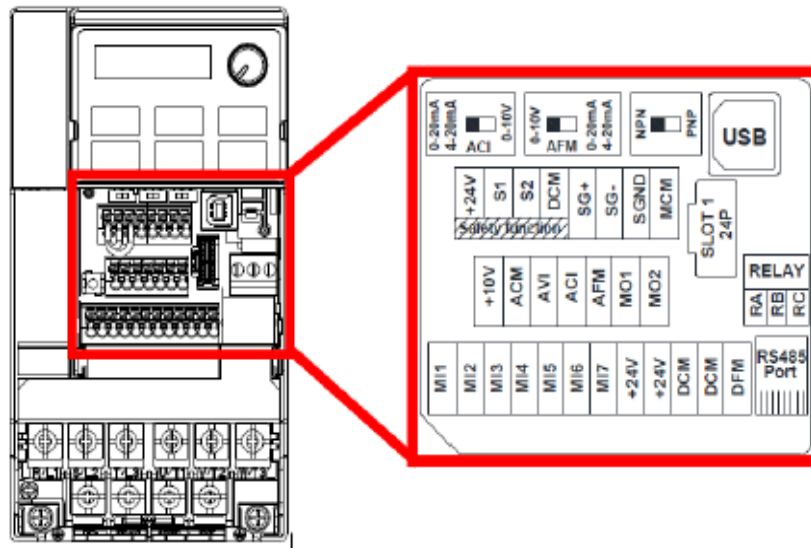

Control Terminations on Variable Frequency Drive

V Series Washer Model	Input Voltage	Max Spin Speed	Jumper Terminal Locations on Variable Frequency Drive (VFD)												
			MI1	MI2	MI3	MI4	MI5	MI6	DCM (Left)	DCM (Right)	24V	ACM	AVI	ACI	10V
T-950	240V	140 G	REMOVE Brown Jumper Between MI5/M01												
		200G											X		X
	208V	140 G	REMOVE Brown Jumper Between MI5/M01												
		200G	No Jumper required												

T-950 Spin Speed Adjustment Jumper Locations

Section 4:

Trouble Shooting

Rapid Advance Mode

To enter the Rapid Advance mode, insert the key into the Rapid Advance/Run/Program lock and turn the key counter-clockwise (CCW). The Rapid Advance mode must be entered during the cycle. If the cycle has not yet started, press the "DOWN" button or the "UP" button to choose a cycle and then the "**START**" button to begin the cycle.

To advance to the next step in the cycle, push both the "UP" and "**START**" buttons at the same time. The display will show "Ad" (advance).

If advancing during a bath, all water valves will turn off and the drain will open until the "open drain" step is completed. The cycle will then continue to the next bath or to the spin of the current bath if the programming includes spin time.

If advancing during a chemical injection of a bath or after a chemical injection of the bath but before the low water level is reached, the injector will turn off and the hot and the cold water valves to the tub will turn on until the low water level is reached or for 30 seconds, whichever comes first. Then the drain will open and proceed to the next step after the Aopen drain@ step is completed.

If advancing before a chemical injection of the bath, the drain will open immediately and the cycle will proceed to the next step when the "open drain" step is completed.

If advancing during a spin, the tumbler will begin to decelerate immediately. However the cycle may proceed to the next bath before the tumbler comes to a complete stop. The cycle cannot be advanced further while the tumbler is decelerating.

If a temperature PCB is installed in the I/O PCB and the temperature programmed from 20 to 90 (Celsius), advancing will turn off the heater relay or steam valve immediately, if either is on, and open the drain after a three second delay. If the display shows a water temperature from 65 to 90 (may be displayed by pressing the "**DOWN**" and "**START**" buttons together), the drain will close again when the washer indicates empty and the hot and the cold water valves to the tub will turn on until the low water level is reached. The cycle will then continue to the next bath, or if programmed, to the spin of the current bath.

To exit the Rapid Advance mode during the cycle, turn the key to Run. The cycle will continue normally.

Notes:

- The cycle cannot be advanced during the open drain@ step of the bathes.
- The cycle cannot be advanced when the hot and cold water valves to the tub are on after advancing during or after a chemical injection.
- The cycle cannot be advanced again while the hot and cold water valves to the tub are on after advancing when the water temperature was 65 to 90.
- The Rapid Advance mode may only be entered after a cycle is started.
- The indicator lights will show which segment the cycle has been advanced.
- The Rapid Advance mode cannot skip the final three tumbles of the cycle. The door lock may remain activated for a couple minutes after the cycle has been completed.
- The chemical injection signals will not turn on if the Rapid Advance mode is entered before the injection.

To end the cycle without waiting for the time to count down, push and hold the "STOP" button for 5 seconds or more. The display will then show the cycle number and be ready to start the next cycle.

Diagnostic Test Cycle (#31)

There is a diagnostic test cycle to assist in both verifying correct operation and identifying functional problems. The test cycle is operated by following these steps:

1. Close the washer door
2. Turn the Run/Program Key to the Program Position. The program mode LED (bottom row right side) will light.
3. Select Test Cycle #31 by using the **Up** and **Down** Arrows on the touch pad. Read the Test Cycle number in the display.
4. Push the green **Start** button. All lights will be on and "00" will be in the display.
5. Push the **Up** arrow to select the following steps:
6. Injection signal can not be tested for output in this cycle

When the correct step is selected for the component that is to be tested, push the **Start** button to operate that component. Releasing the **Start** button removes power to the component being tested.

Step 1: Door Locking Solenoid (Door Sol.# 3 red output light will be lit. Green input #3 and #4 should be lit.)

Step 2: Door Locking Thermoactuator (Lock Thermo # 2 red output will be lit.)

Step 3: Door Unlocking Thermoactuator (Unlock Thermo # 1 red output will be lit.)

Step 4: Close Drain Valve (Drain Valve # 4 red output light will be lit.)

Step 5: Cold Water Valve for the tub (Cold Tub # 7 red output light will be lit.) The pressure switch low level setting can be tested at this point. The drain valve is closed and cold water is on for as long as the START button is pushed. When the water level reaches a low level, the water valve will turn off and no additional cold water can be added. (Green input LED #13 should now be lit.)

Step 6: Cold Water Valve for the dispenser (Cold Dispenser # 6 red output light will be lit.) The pressure switch low level setting can also be tested with this step. (See step 5)

Step 7: Hot Water Valve for the tub (Hot Tub #5 red output light will be lit.) The pressure switch high level setting can be tested at this point. The drain valve is closed and hot water on for as long as the START button is pushed. When the water level reaches a high level, the water valve will turn off and no additional hot water can be added. (Green input led #15 should now be lit.)

Step 8: Hot Water Valve for the dispenser (Hot Dispenser # 8 red output light will be lit.) The pressure switch high level setting can also be tested with this step. (See step 7)

Step 9: Tumble clockwise (FWD. #13 red output light will be lit)

Step 10: Tumble counter clockwise (REV. #14 red output light will be lit)

Step 11: Open Drain Valve (insures that drain valve is open before spin)

Step 12: Intermediate Extract (Rev.#13 and Speed1 #15 red output light will be lit.)

Step 13: High Speed Extract (Rev.#13 and Speed 1#15 and Speed 2 #16 red output light will be lit.)

Warning: If the washer has had any of the 30 cycles changed from the factory settings, do not use Step 14 unless you want to reset all 30 cycles back to the factory settings.

Step 14 will delete any changes made to all 30 cycles.

Step 14: Reset all 30 Cycles to Factory Settings (must push the **Start** Button and hold it, then push the Up Arrow button to reset to Factory Settings)

To Exit the Test mode, push the red **Stop** button and turn the Run/Program Key back to the Run position.

WN_____ Input/Output PCB Board

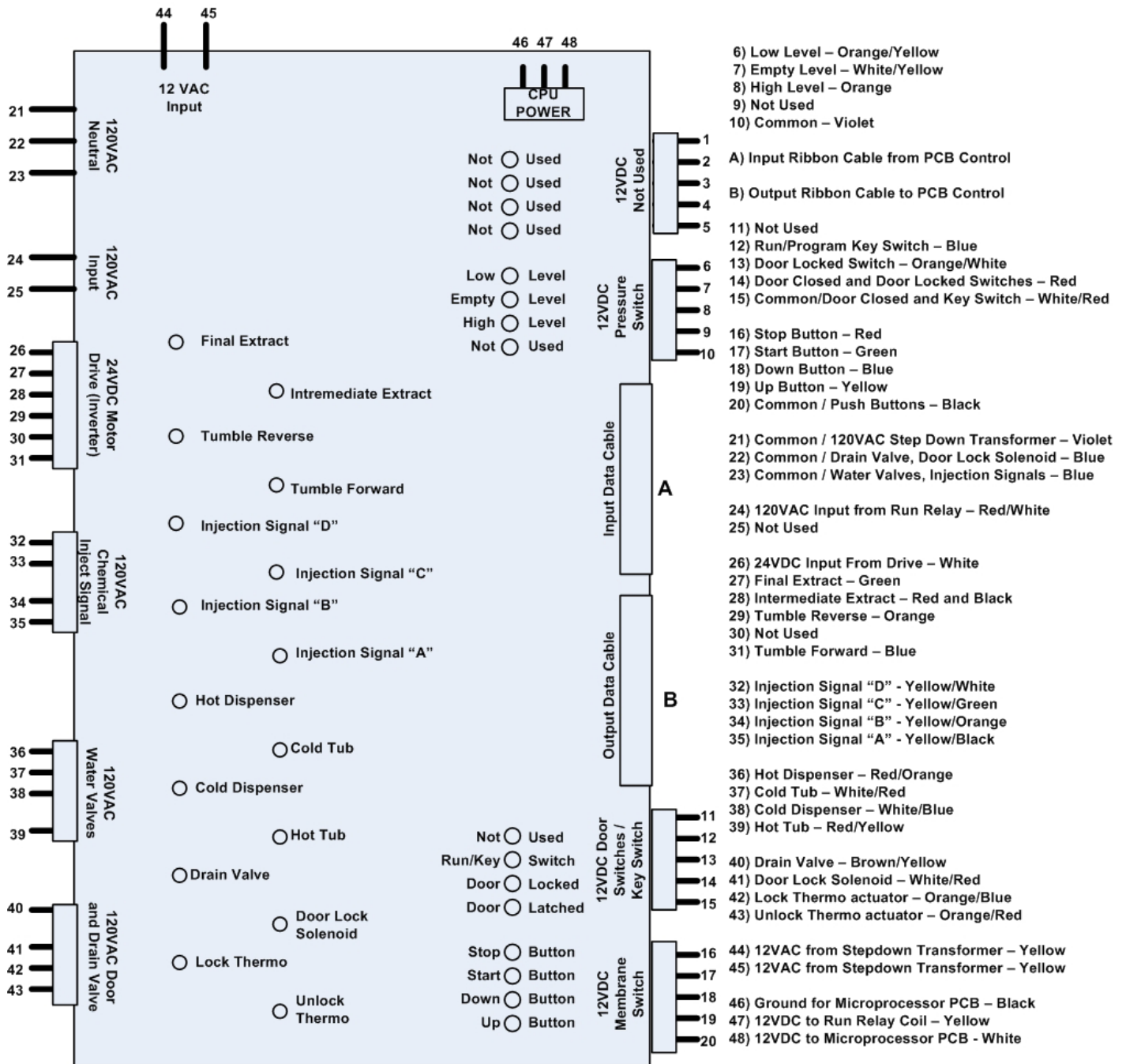

WN_____ Microprocessor PCB Board

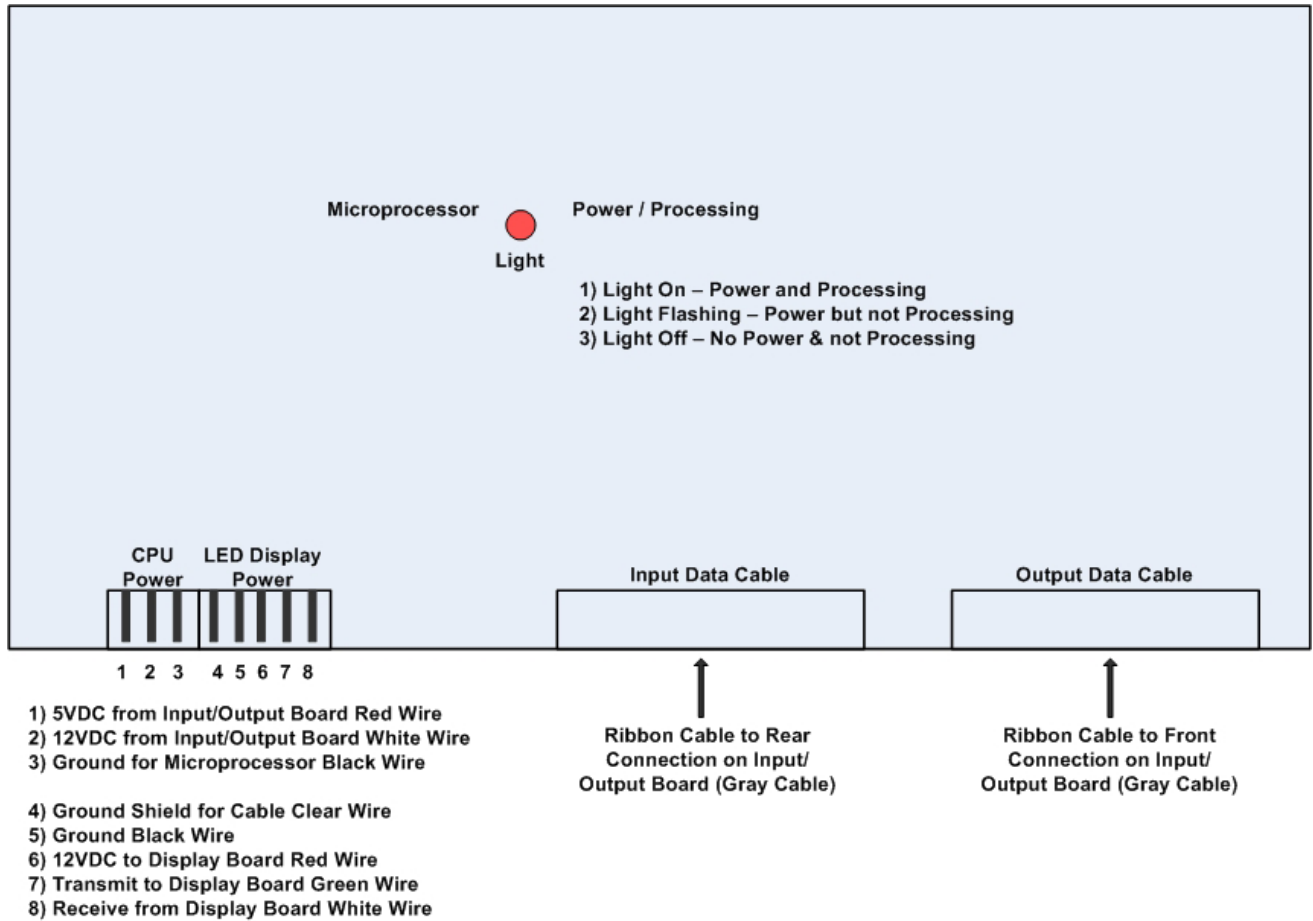

Common Troubleshooting Solutions

Symptom	Probable Cause	Suggested Remedy
Machine does not start	Power Supply	Check these areas: Circuit breakers, Voltage, Power leads, Power connections
	Start Button	Check for green start button, light on Input/Output PCB # 6 when button is depressed. If no light check membrane switch assembly and ribbon cable
	Control Breaker or Fuse	Check 1.5 amp (T-1200. uses 2.5amp) breaker or fuse for continuity. If no continuity, replace breaker or fuse.
	Door Switch	Check for continuity through door switches when door is closed and locked. Check Input/Output PCB for green door closed light # 4 and green door locked light #3 showing that door switches are functioning correctly. If no continuity or green light on when door closed and start button pushed, check door switch and wiring assembly
	Control Transformer	Check voltage output from control transformer for 120VAC. If voltage is incorrect, replace transformer.
	Check PCB Board	Check all wire connections for sure contacts.
	CPU Board	Single red light should be illuminated. If light is flashing or not on, remove power from washer for 2 minutes to reset board. Reapply power to washer and check red light. If on solid, all okay. If still flashing or not on, replace CPU board.
	Check Relay PCB	Check all wire connections for sure contact.
	Check Door Solenoid	Check that 120 vac power is at solenoid after start button is pushed.
Machine starts then stops	Door Switch Ass'y	I/O PCB must have green input lights, DOOR LOCK# 3, DOOR CLOSED #4, TUB EMPTY #14, RUN KEY #2. START #6 WILL BE ON WHEN pushed. If these are not on, check door switches and wiring to and from control panel.
	Door Locking Solenoid	Check I/O PCB red output light DOOR SOL. #3 is on. 120 vac to solenoid? Is linkage rod adjusted properly?
Door does not lock	CPU Board, Ribbon Cable or Input/Output Board	Check Input/Output PCB for green input door closed light #4 and green input door locked light . Check #3 single red light on CPU . Single red light should be illuminated. If light is flashing or not on, remove power from washer for 2 minutes to reset CPU. Reapply power to washer and check red CPU light. If on solid, CPU okay. If still flashing or not on, replace CPU board. If CPU tests okay, change Ribbon Cables between CPU and Input/Output PCB. (Check with factory for latest testing procedures for I/O PCB) If no voltage, replace I/O PCB.
	Door Locking Gear Motor	Check to insure that solenoid is receiving 120 volts from Input/Output PCB. Is I/O PCB red output light #3 on? If 120 vac and output light is lit, replace solenoid.
	Door Switch	Check for continuity through door latch switch when door closed. If no continuity, adjust or replace door switch.
Door will not open	Door Rod	Check to see if the mechanism is stuck or binding and not allowing the door lock solenoid to open.

Symptom	Probable Cause	Suggested Remedy
Door will not open	Thermoactuator	Check to see if thermoactuator(s) and/or its mechanism is stuck or binding and not allowing the door lock solenoid to open. Check to be sure that red light on Input/Output PCB for locking thermoactuator #2 is not illuminated and that Input/Output PCB is not sending 120VAC power to the locking thermoactuator during the last 70 seconds of the cycle. Check to be sure that red light on Input/Output PCB for unlocking thermoactuator #1 is illuminated and that Input/Output PCB is sending 120VAC to the unlocking thermoactuator during the last 30 seconds of the cycle.
	Door Lock Solenoid	Check that door lock solenoid is not stuck closed. Check to be sure that Input/Output PCB is not sending 120VAC power to door locking solenoid. Be sure that red light on Input/Output PCB for door locking solenoid #3 is not illuminated. If door lock solenoid is receiving 120VAC, check CPU, Ribbon Cable and Input/Output PCB above.
	Input/Output Board	Check red door lock solenoid light #3 is on input/output board. If illuminated, remove power to washer for 2 minutes to reset CPU board. Reapply power to washer and check the door lock solenoid light #3. If no light, okay. If red light is still on, check the CPU board as described above under "Door does not lock". If CPU tests okay, change Ribbon Cables between CPU and input/output board. If red door lock solenoid output light on input/output board is illuminated, check that 120VAC is going from the input/output board to the door locking solenoid. If voltage, replace I/O PCB.
Machine starts but will not advance in the cycle	Water Valves	Check to insure that water valves are operating. If not, check to be sure that red light on Input/Output PCB for water valves is illuminated #5,6,7,8 and that input/output board is sending 120VAC to the water valve. If 120VAC, change water valve. If no voltage check Input/Output PCB.
	Drain Valve	Check to insure that drain valve is closing. If not, check for 120VAC to drain valve from Input/Output PCB red light # 4. If 120VAC, change or clean drain valve. If no voltage, check CPU board, Ribbon Cable and I/O PCB.
	Fill Hose Screens and Water Valve Screens	Check all screens for obstructions and clean.
	Water	Check to insure that water is turned on and operating.
	Pressure Switch Hose	Check hose for holes. Be sure the inlet end of the large part of the hose is lower than the rest of the hose and is free of debris.
	Pressure Switch	Pressure switch must be in the low or high position to close the circuit to the Input/Output board. Either the green low level or high level light on the input/output board must be lighted. Check pressure switch continuity between terminals #31 & #22 for low level and #31 and #32 for high level.

Symptom	Probable Cause	Suggested Remedy
Machine starts but will not advance in cycle (cont.)	CPU Board, Ribbon Cable, or Input/Output Board	Check Input/Output PCB for(red output LED will not light for water valve and drain valve #4,5,6,7,8, . If no output lights illuminated, check single red light on CPU board. Single red light should be illuminated. If light is flashing or not on, remove power from washer for 2 minutes to reset board. Reapply power to washer and check red CPU light. If on solid, CPU okay. If still flashing or not on, replace CPU board. If CPU tests okay, change Ribbon Cables between CPU and input/output board. (Check GREEN input LED #14 tub empty has lit in a drain mode of formula.) (Make sure Green input #13 or #14 are lit if Fill portion of formula is being called for.) If red drain valve or water valve output light on Input/Output PCB is lit, check to insure that 120VAC is going from the Input/Output PCB to the drain valve or water valve. If no voltage, replace I/O PCB.
Machine tumbles in only one direction	Variable Frequency Drive	Check blue and orange wires on variable frequency drive for alternating 0V to 24 VDC for forward and reverse direction from the Input/Output PCB. If no voltage, see CPU board, Ribbon Cable or Input/Output PCB below. Be sure to check wire connections at drive.
	CPU Board, Ribbon Cable, or Input/Output Board	Check Input/Output PCB for alternating or Input/Output PCB red output lights for forward #13 and reverse #14. If no red output lights illuminated, check single red light on CPU board. Single red light should be illuminated. If light is flashing or not on, remove power from washer for 2 minutes to reset board. Reapply power to washer and check red CPU light. If on solid, CPU okay. If still flashing or not on, replace CPU board. If CPU tests okay, change Ribbon Cables between CPU and Input/Output PCB. (If red forward #13 and reverse #14 output lights on the Input/Output PCB are illuminated, check to insure that 24VDC is going from the Input/Output PCB to the variable frequency drive. (SEE WASHER SCHEMATIC FOR TROUBLESHOOTING VFD.) If no voltage, replace I/O PCB.
Washes but does not give intermediate spin	Pressure Switch	Pressure switch must be in the empty position to give close the circuit to the Input/Output PCB. The green input tub empty light #14 on the Input/Output PCB must be lighted. Check pressure switch for continuity across terminals indicating pressure switch has reset to empty.
	Variable Frequency Drive	Check Variable Frequency Drive Check all wires on drive to insure a good connection. Check LED display at VFD before powering down 1) Disconnect power to washer for 2 minutes to reset motor drive. Reconnect to power and check for LED display on VFD 2) Check incoming power to washer for correct voltage. Line voltage out of the specified operating range will cause the drive to fault.

Symptom	Probable Cause	Suggested Remedy
Washes But does not give intermediate spin (cont.)	CPU board, Ribbon Cable Input/Output PCB	Check Input/Output PCB for illuminated red output light for intermediate spin (Speed 1) #15 and #14 FOR REVERSE. If no red output light illuminated, check single red light on CPU board. Single red light should be illuminated. If light is flashing or not on, remove power from washer for 2 minutes to reset board. Reapply power to washer and check red CPU light. If on solid, CPU okay. If still flashing or not on, replace CPU board. If CPU tests okay, change Ribbon Cables between CPU and Input/Output PCB. (Check with factory for latest testing procedures for I/O PCB). If red speed 1# output light # 15 on the Input/Output PCB is illuminated, check to insure that 0VDC is going from the Input/Output PCB to the variable frequency drive. If no voltage, replace I/O PCB.
Machine starts and advances through cycle but motor does not operate	Variable Frequency Drive and Motor	Check small green, blue, orange, black, white, red wires (shielded cable) from the VFD to insure a good connection at each termination point at drive or at relays and including all moxex connectors. 1. Disconnect power to washer for 2 minutes to reset motor drive. 2. Check incoming power to washer for correct voltage. Line voltage out of the specified operating range will cause the drive to fault, lighting the red fault light. 3. Check motor. Disconnect from power. Disconnect the three wires that operate the motor from terminals T-1, T-2, T-3 in the drive. Reconnect power to the washer
	CPU board, Ribbon Cable Input/Output PCB	Check Input/Output PCB for illuminated red motor output lights. If no red output lights illuminated, check single red light on CPU board. Single red light should be illuminated. If light is flashing or not on, remove power from washer for 2 minutes to reset board. Reapply power to washer and check red CPU light. If on solid, CPU okay. If still flashing or not on, replace CPU board. If CPU tests okay, change Ribbon Cables between CPU and Input/Output PCB. (Check with factory for latest testing procedures for I/O PCB) If red motor output lights on Input/Output PCB are illuminated, check to insure that 0VDC is going from the input/output board to the variable frequency drive. If no voltage, replace I/O PCB.
	Run Relay	Check to see if 12VDC to relay coil. If not check I/O PCB for 12VDC output. Check if 0VDC through contacts (white wire) to I/O PCB.

Symptom	Probable Cause	Suggested Remedy
Intermediate speed #1 Works No high speed #2	Variable Frequency Drive and Motor	Check small green, black, white, red wires (shielded cable) from the VFD to insure a good connection at each termination point at drive or at relays and including all molex connectors. Check that green Hi speed wire at drive terminal is giving a 0 vdc reading between white and green and assure that signal is getting to drive. 1. Disconnect power to washer for 2 minutes to reset motor drive. Reconnect to power and check for run light. Run--okay. 2. Check incoming power to washer for correct voltage. Line voltage out of the specified operating range will cause the drive to fault. 3. Check motor. Disconnect from power. Disconnect the three gray wires that operate the motor from terminals T-1, T-2, and T-3 in the drive. Reconnect power to the washer.
	CPU Board, Ribbon Cable, Input/Output PCB	Check Input/Output PCB for illuminated red Speed 1 #15 and high Speed 2 #16 output lights. If no red output lights illuminated, check single red light on CPU. Single red light should be illuminated. If light is flashing or not on, remove power from washer for 2 minutes to reset board. Reapply power to washer and check red CPU light. If on solid, CPU okay. If still flashing or not on, replace CPU. If CPU tests okay, change Ribbon Cables between CPU and input/output PCB. (Check with factory for latest testing procedures for I/O PCB) If red intermediate and high extract output lights on input/output board are illuminated, check to insure that 0 VDC is going from the Input/Output PCB to the variable frequency drive. If no voltage, replace I/O PCB.
Hot water does not enter the tub.	Water Valves	Check to insure that water valve is operating. If not, check for 120VAC to water valve from Input/Output PCB. If 120VAC, change water valve. If no voltage check Input/Output PCB as described below.
	Fill Hose Screens Water Valve Screens	Check all screens for obstructions and clean.
	Water	Check to insure that water is turned on and operating.
	Pressure Switch Hose	Check hose for holes. Be sure the inlet end of the large part of the hose is lower than the rest of the hose and is free of debris.
	Pressure Switch	Pressure switch must be in the empty position to close the circuit to the Input/Output PCB. The green empty light #14 on the Input/Output PCB must be on. Check pressure switch for continuity across terminals #31 & #22 indicating pressure switch has reset to empty.
	CPU Board, Ribbon Cable Input/Output PCB	Check Input/Output PCB for illuminated red water or Input/Output PCB valve output light. If no red output light #5 illuminated, check single red light on CPU Board. Single red light should be illuminated. If light is flashing or not on, remove power from washer for 2 minutes to reset board. Reapply power to washer and check red led.

Symptom	Probable Cause	Suggested Remedy
Hot water does not enter the tub (cont.)	CPU Board, Ribbon Cable, Input/Output PCB (cont.)	CPU light. If on solid, CPU okay. If still flashing or not on, replace CPU board. If CPU tests okay, change Ribbon Cables between CPU and Input/Output PCB. If red hot tub output light #5 on Input/Output PCB is illuminated, check to insure that 120VAC is going from the Input/Output PCB to the water valve. If no voltage, replace I/O PCB.
Cold water does not enter the tub	Water Valves	Check to insure that water valve is operating. If not, check for 120VAC to water valve from Input/Output PCB. If 120VAC, change water valve. If no voltage check Input/Output PCB.
	Fill Hose Screens Water Valve Screens	Check all screens for obstructions and clean.
	Water	Check to insure that water is turned on and operating.
	Pressure Switch Hose	Check hose for holes. Be sure the inlet end of the large part of the hose is lower than the rest of the hose and is free of debris.
	Pressure Switch	Pressure switch must be in the empty position to close the circuit to the Input/Output PCB. The green empty led tub empty #14 on the Input/Output PCB must be on. Check pressure switch for continuity across terminals #31 & #22 indicating pressure switch has reset to empty.
	CPU board, Ribbon Cable, Input/Output PCB	Check Input/Output PCB for illuminated red or Input/Output PCB water valve output light. If no red output light #8 illuminated, check single red light on CPU board. Single red light should be illuminated. If light is flashing or not on, remove power from washer for 2 minutes to reset board. Reapply power to washer and check red CPU light. If on solid, CPU okay. If still flashing or not on, replace CPU board. If CPU tests okay, change Ribbon Cables between CPU and Input/Output PCB. (Check with factory for latest testing procedures for I/O PCB) If red water valve output light on input/output board is illuminated, check to insure that 120VAC is going from the Input/Output PCB to the water valve. If no voltage, replace I/O PCB.
No hot water in detergent dispenser	Water Valves	Check to insure that water valve is operating. If not, check for 120VAC to water valve from Input/Output PCB. If 120VAC, change water valve. If no voltage check Input/Output PCB.
	Fill Hose Screens Water Valve Screens	Check all screens for obstructions and clean.
	Water	Check to insure that water is turned on and operating.
	CPU Board, Ribbon Cable, Input/Output PCB	Check Input/Output PCB for illuminated red or Input/Output PCB water valve output light. If no red output light #8 illuminated, check single red light on CPU board. Single red light should be illuminated. If light is flashing or not on, remove power from washer for 2 minutes to reset board. Reapply power to washer and check red CPU light. If on solid, CPU okay. If still flashing or not on, replace CPU board. If CPU tests okay, change Ribbon Cables between CPU and Input/Output PCB. If red output light #5 on input/output PCB is illuminated, check to insure that 120VAC is going from the Input/Output PCB to the water valve. If no voltage, replace I/O PCB.

Symptom	Probable Cause	Suggested Remedy
Water does not flush soft-ner compartment	Water Valves	Check to insure that water valve is operating. If not, check for 120VAC to water valve from Input/Output PCB. If 120VAC, change water valve. If no voltage check Input/Output PCB.
	Fill Hose Screens Water Valve Screens	Check all screens for obstructions and clean.
	Water	Check to insure that water is turned on and operating.
Water Level too high	Pressure Switch	Pressure switch must be in the low or high position to close the circuit to the Input/Output PCB. Either the green low level #13 or high level light #15 on the Input/Output PCB must be lighted. Check pressure switch continuity between terminals #31 & #22 for low level and #31 and #32 for high level.
	Pressure Switch Hose	Check hose for holes. Be sure the inlet end of the large part of the hose is lower than the rest of the hose and is free of debris.
	CPU Board, Ribbon Cable, Input/Output PCB	Check Input/Output PCB for illuminated green low #13 or high level input light #15. If green input light is illuminated, check single red light on CPU board. Single red light should be illuminated. If light is flashing or not on, remove power from washer for 2 minutes to reset board. Reapply power to washer and check red CPU light. If on solid, CPU okay. If still flashing or not on, replace CPU board. If CPU tests okay, change Ribbon Cables between CPU and Input/Output PCB. (Check with factory for latest testing procedures for I/O PCB) If still not corrected, change Input/Output PCB.
Water comes in but level does not rise	Drain Valve	Check these areas - Drain valve blockage - Drain valve motor and gear train. If power but drain valve does not close, replace valve. - Power to the drain valve. If no power to drain valve, check (brn/yel) circuit for power.
	Water Valves	Check or replace diaphragms
Water drains slowley	Drain System	Check hoses and drain valve for blockage. Clean if necessary. Check building drains for blockage or inadequate size.
Water leakage around loading door	Door Adjustment	Door may need adjustment due to abuse or wear around loading. Check tightness around perimeter using a dollar bill. Adjust left to right tightness by shims at door lock or hinge side. It is important to center gasket to tub opening before tightening door to hinge bolts. Chalk may be used on tub front to show point of contact with tub. If gasket is deformed, worn, or damaged, replace. Refer to parts section for door gasket expander kit.
Excessive vibration	Mounting System	Check these areas: Strength of mounting structure, concrete, or base. Mounting bolts may be loose and need tightening.
	Drive Belt	Worn drive belt can cause vibration and noise.
	Pulleys	Damaged pulleys.
	Underloading	NOTE: SMALL LOADS CONTRIBUTE TO OUT OF BALANCE LOADING AND INCREASE VIBRATION.!!!

Electrical Path Circuit Schematics

Start Circuit

Power is applied to the control trough on L1 & L2. 208-240 VAC is applied to the Control Transformer that steps the voltage down to 120 VAC. 120 VAC travels through the 1.5 amp Circuit Breaker and on to the Step Down Transformer. The Step Down Transformer steps 120 VAC down to 12 VAC for the Input/Output PCB. The Input/Output PCB regulates 12VAC to 12VDC to power the output relays and then down to 5VDC to power the Microprocessor.

The Variable Frequency Drive is powered by either L1 & L2 on single phase or L1, L2 & L3 on three phase. The DC ground is sent out of the Variable Frequency Drive from terminal DCM on the white wire to and through contacts on the R1 Run Relay. As soon as the door is locked, 12 VDC is supplied from the Input/Output PCB to the Run Relay coil and closes the relay. The R1 Run Relay supplies a DC ground, through contacts, to the Input/Output PCB. A 120 VAC signal powers most outputs on Input/Output PCB. The DC ground signal is for the motor control. (See fill, wash, section for details)

After selecting a cycle, depressing the Start Button (green input light #6 on Input/Output Board will be lit while button is depressed) signals the Microprocessor to begin the cycle. All signals come into the Microprocessor through the Input/Output PCB.

The door is locked by sending 120VAC from the Input/Output PCB (red output light #3 on Input/Output PCB will be lit) on the white/red wire to the Door Lock Motor. With the door locked a 12VDC signal is sent back to the Input/Output PCB from the Door Locked Switch on the orange/white wire (green input light #3 on Input/Output PCB will be lit).

The Lock Thermoactuator is powered with 120VAC from the Input/Output PCB (red output light #2 on Input/Output PCB will be lit) on the orange/blue wire. The Lock Thermoactuator will be powered for 3 minutes and will then be cycled on for 40 seconds and off for 40 seconds until the last 70 seconds of the cycle at which time it is no longer powered.

The Drain Valve is powered closed with 120VAC from the Input/Output PCB (red output light #4 on Input/Output PCB will be lit) on the brown/yellow wire.

Fill - All Wash, Rinse & Empty Batches

The selected Water Valves to fill the tub (hot, cold or both) are powered with 120VAC from the Input/Output PCB (red output light #5, or #7 or both on Input/Output PCB will be lit) on the white/red (cold) wire and/or the red/yellow (hot) wire. The two Water Valves to flush the Powder Dispenser are powered with 120VAC from the Input/Output PCB (red output light #6,#8 on Input/Output PCB will light) on the red/orange wire (Hot Water Flushes, #8 on I/O PCB, Detergent For 20 seconds In Wash Cycle) and on the white/blue wire (Cold Water Flushes, #6 on I/O PCB, Softener For 20 Seconds In Final Rinse)

As the washer fills the tub through the back of the machine with either one or both the C1 Cold and H1 Hot Water Valves, the Wash Basket will tumble one direction for 12 seconds, pause, and then reverse direction for 12 seconds. This tumbling process is controlled by the Microprocessor supplying a signal to the Input/Output PCB relays which in turn supply DCM ground, through contacts, to the Variable Frequency Drive DCM to FWD & REV to operate the Drive Motor.

Forward direction is supplied DCM ground from the Input/Output PCB (red output light #13 on Input/Output PCB will be lit) on the blue wire to the FWD terminal on the Variable Frequency Drive. Reverse direction is supplied with DCM ground from the Input/Output PCB (red output light # 14 on Input/Output PCB will be lit) on the orange wire to the REV terminal on the Variable Frequency Drive.

The cycle time count down is stopped in each bath until low level is reached. The Input/Output PCB receives a 12VDC signal from the Pressure Switch (green input light #13 on Input/Output PCB will be lit) on the orange/yellow wire when low level is reached. The EMPTY bath may be chosen for any bath including the final rinse bath. If empty bath (EE) is chosen the timer will STOP for 40 seconds and then continue counting down as programmed. No chemical injections will be allowed because no water level reached.

Tumble - Variable Frequency Drive & Micro Test Procedure

The single red LED in the middle of the CPU PCB should be lit when the microprocessor has power and is processing data. Red light flashing means it has power But is NOT processing data. Remove power from machine for 2 minutes to reset board. If no red light, there is no power to the board.

This testing procedure should be followed. A DCM ground control circuit is used on this Variable Frequency Drive. The white wire supplies a DCM ground through the Run relay contacts. When testing this unit you will get a 24VDC reading when NOT calling for that action. A 0 VDC reading will show when that rotation direction is called for. You must take the VDC reading between either two points DCM and FWD OR REV. (Remember - 0 Volts when calling for an extract or wash speed). The Variable Frequency Drive also uses two braking resistors to dissapate the voltage generated after motion has been signaled to stop. In these models they are both rated at 160 ohms. Please remember that when testing these that a 160 ohms reading does not always confirm a good resistor. The resistors could be breaking down under heat load. If these resistors are grounded or open they could possibly make this unit malfunction.

Liquid Chemical Signals

Chemical injections signals are available in all bathes. If programmed, the following numbers will provide 120 VAC signals to the designated terminals on the back of the washer. All Chemical injections signals are delayed until 10 seconds after the tub starts to fill with water. All signals are 10 seconds in duration.

Intermediate Extract Circuit

Intermediate Extract can be programmed after all bathes except the Final Rinse (see Final Extract). If programmed for Intermediate Extract, the Microprocessor will signal the Input/Output PCB to supply a DCM ground (red output light #14 on Input/Output PCB will be lit) on the orange wire to the REV terminal on the Variable Frequency Drive. This insures that the tub is turning the correct direction before starting into spin. Next, the Input/Output PCB supplies a DCM ground (red output light #15 on Input/Output PCB will be lit) on both the red M13 and black wires M12 to the (intermediate spin) terminals on the Variable Frequency Drive.

Final Extract Circuit

Same sequence as Intermediate Extract but adds the following. The Input/Output PCB supplies a DCM ground (red output light #16 on Input/Output PCB will be lit) on the green wire to the (final spin) terminal M11 on the Variable Frequency Drive. REV; M13; M12 ; M11 all 4 terminals are supplied a DCM ground for high spin.

End of Cycle

At the end of the cycle, the Display PCB will read 0 minutes, the Beeper will sound for 5 seconds in 1 second intervals and the End of Cycle Light will come on. The washer door must be opened before the display resets and allows a different cycle to be selected. You can run the same cycle again without opening the door BUT you must open to reset to another cycle.

Section 5:

Machine Service Procedures

Top Panel Removal

- Step 1:** Remove 4 screws that hold detergent dispenser to top panel.
- Step 2:** Unlock top panel lock.
- Step 3:** Raise top panel, slide to the rear to release from back clips and lift off.

Front Panel Removal (Loading door needs to be removed first on T-900;T1200)

- Step 1:** Remove 2 screws between front panel top and front (located behind control panel).
- Step 2:** Remove the two screws in the middle of the front panel.
- Step 3:** Pull panel out at the bottom to about a 45 degree angle to detach the top lip and remove.

Back Panel Removal

- Step 1:** Remove all screws holding back panel in position except the bottom row.
- Step 2:** The bottom row of screws are slotted and only need to be loosened and to lift off panel.

NOTE: The back panel is not only a safety requirement but also contributes to the rigidity of the cabinet.

Drain Valve Access

For access to drain valve, remove lower service panel. The drain valve is a ball type and is powered closed by the drain valve motor. It is mounted under the washer tub on the left side. It is spring loaded open. If power is interrupted to the washer, the motor releases the sealing ball, allowing the drive spring to open the valve. With the valve open, all water in the washer will drain out.

Drain Valve Cleaning

- Step 1:** Loosen the clamp on the tub hose at the drain valve end and remove the hose from the drain valve.
- Step 2:** Loosen the drain hose clamp on the back of the drain valve. Remove two drain valve mounting racket screws from the frame of the washer.
- Step 3:** **Disconnect Brown/Yellow and Blue wire from the drain valve.**
- Step 4:** Remove the drain valve and bracket assembly.

Detergent Dispenser (T-600, T-900)

Remove top panel to access dispenser. (see Removing Top Panel) Detergent is flushed from the front of the compartment and fabric softener is flushed from the back. There will be a small amount of water left in the fabric softener compartment after each use.

Vacuum Breaker (also called an air gap)

In the left rear of the cabinet is the vacuum breaker. It guides the water to the tub and dispenser and prevents a back flow of water.

Water Valves

Remove top panel to access water valves. (see Removing Top Panel) The two dual outlet water valves are mounted to the rear channel with two screws each. Always check inlet screens to be sure that they are clean. Disassembly requires the removal of two solenoid screws and three valve body screws. Below the solenoid coil is a solenoid guide, armature, armature, spring and diaphragm. All valve parts are available individually or as a complete unit.

Door Lock Assembly Operation

After loading the clothing, the door should be closed and latched. The locking cam on the door contacts the latching switch actuator which closes the latching switch. The specified number of coins should now be added to start the washer. The solenoid pulls up on the locking pawl by use of a linkage rod. The locking pawl has two jobs. The first is to lock the door. This is accomplished by blocking the locking cam on the door so that it can't rotate to unlock. The second job is to close the two piggyback lock sensing switches. These switches control power to all of the controls. If the door unlocks for any reason, these two switches will stop the machine. When the door handle is 1/4 to 1/2 of an inch from its fully closed position, the latching switch should close. The two piggyback lock sensing switches should be open when the door is unlocked and should be closed when the door is locked.

Accessing the Door Lock Assembly

After removing the front panel, the door lock assembly can now be accessed.

Adjustment for Door Lock Assembly

The latching switch and the piggyback lock sensing switches all have slotted mounting for easy adjustment.

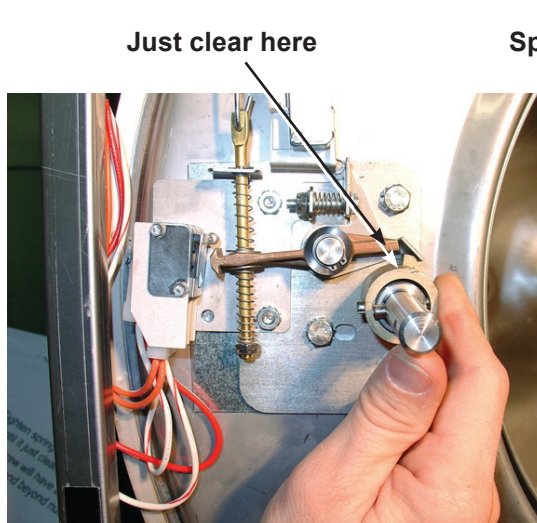

Step 1: Set door cam over pin. Here you can see the door cam away from the door lock assembly.

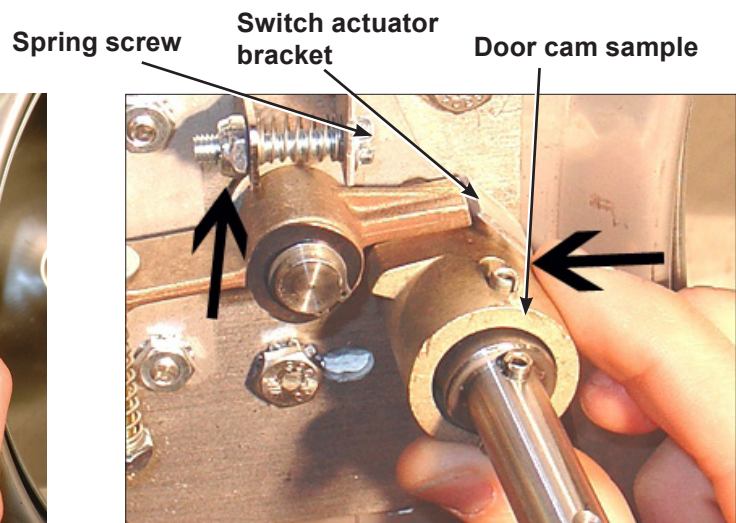

Step 2: Tighten spring screw on switch actuator bracket arm until it just clears cam OD. at base of door lock assembly.

Note: Adjustment to this bracket usually is not necessary as next step is used more in field.

Flat blade screw on door switch latching

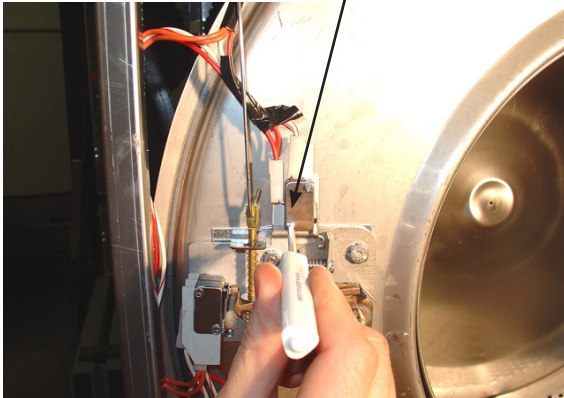

Step 3: With switch actuator bracket adjusted you will now need to adjust single switch by loosening 2 flat blade screws and allowing swivel of switch. Move switch towards above bracket until it actuates. Now tighten flat blade screws. Use a .040 thickness guage to insert between bracket and switch and the switch should close and open again upon removal of thickness guage.

Door cam check position

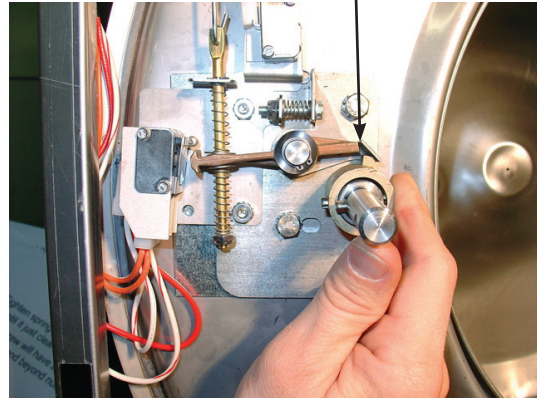

Step 4: Check for switch actuation at partial turn of cam as in operation above. Door handle goes from horizontal to six o'clock vertical.

Door lock rod **Locking pawl blocking**

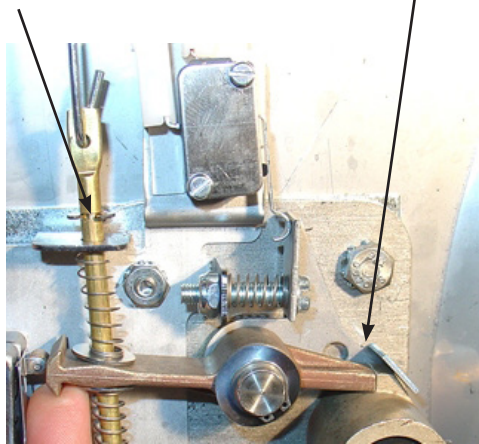

Step 5: Check that lock pawl arm swings to cam lobe to lock position.

Adjustment screw for (piggyback switches)

Top of flat end of locking pawl.

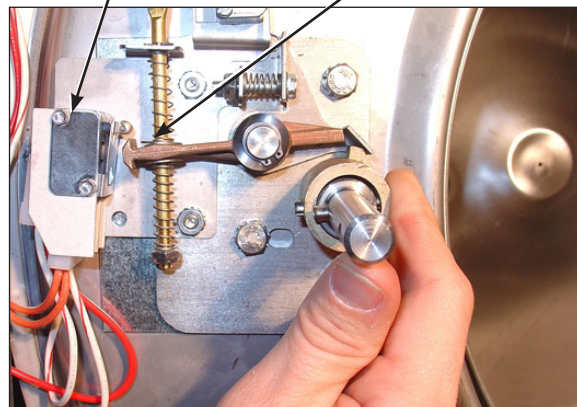

Step 6: The lock stacked switches (piggyback) must be adjusted as door lock solenoid pulls up on door rod and locking pawl is now blocking door cam from turning and is in full up position. The stacked switches (piggyback) have a single actuator arm and it must actuate when single actuator roller wheel rolls to flat side of locking pawl. You will also notice a .040 gap between actuator arm and switch bodies.

Note: Both stacked switches must operate together!

Adjusting the Loading Door

The door can be adjusted by changing the number of shims behind the door hinge and the door lock assembly. The vertical fit of the door to the tub can be altered by loosening the door hinge bolts and raising or lowering the door before retightening. It is important for the door to be centered on the tub front. By chalking the front of the tub and closing the door to transfer that line to the gasket, the centering can be evaluated. It is also important for door pressure to be similar around the door perimeter. Door pressure can be evaluated by inserting a dollar bill in several positions and tugging on it. See Parts Section for kit to increase door sealing pressure.

Loading Door Removal



Step 1: Support door to prevent dropping.



Step 2: Remove 2 or 3 bolts holding hinge retainer clamp or lower leaf to the door ring. Lift up door off and set aside.

Loading Door Hinge Removal



Step 1: First remove loading door, front panel and masking ring if used.



Step 2: Remove 3 screws holding door hinge. Shims may be present between hinge and tub front. The number may be increased or decreased to adjust right side door pressure.

Note: Door hinge mounting bolts penetrate tub front and require silicone sealer applied to holes when reinstalling.

Loading Door Disassembly

Step 1: Remove the loading door as outlined above. Lay the door on a flat surface with the glass down

Step 2: While holding down on the door glass, lift up on the door ring and roll back the lip of the gasket with your fingers.

Step 3: Work all the way around the gasket and the glass is out.

Loading Door Reassembly

Step 1: Lay the door ring face down on a flat surface. Start the glass into one side of the door gasket.

Step 2: Use one hand underneath to push the gasket out and the other hand on the top pulling the gasket in place

Step 3: The front lip of the door gasket should be checked for proper seating.

Front Control Panel Name Plate Decal

The name plate on washer front is adhesive backed.

Front Control Panel Name Plate Removal

The name plate may be removed by simply peeling it off.

Re-Installation of Name Plate

Step 1: Remove any remaining glue from the control panel.

Step 2: Before removing the paper backing from the name plate, check fit to the control panel. The program push buttons are the locating guides.

Step 3: Remove the paper backing from the right side of the name plate, position it on the panel and press right end into place. Peel the backing from the left end and press into place.

Outer Cabinet Removal

T-600

Removal of Cabinet T-600

- Step 1:** The power supply, water hoses, and drain connection must all be disconnected before proceeding with the disassembly.
- Step 2:** Now remove the lower service panel and the top panel assembly.
- Step 3:** Remove the left and right lower front panel screws that retain the panel to the chassis.
- Step 4:** Remove the bottom row of back panel screws.
- Step 5:** Remove the loading door.
- Step 6:** Remove the screws along the bottom of each side panel. When reinstalling these screws do not overtighten.
- Step 7:** Remove clamp and soap dispenser hose where it attaches to the tub inlet. Disconnect the door lock wires from all switches and the door lock solenoid.
- Step 8:** Disconnect pull rod between solenoid and door lock assembly. Disconnect the wires to the dump valve at the bottom of the machine.
- Step 9:** Disconnect the wires to the drive motor from the VFD T1, T2, T3.
- Step 10:** Remove the clamp and the hose from the vacuum breaker where it connects to the inlet on the back of the tub.
- Step 11:** Remove the pressure switch hose from the bottom of the switch.
- Step 12:** It should now be possible for two people to lift the cabinet up and off of the front of the machine and set it aside.

Door Locking Gear Motor

The door locking gear motor is powered shut with control voltage to lock the door and releases when voltage is removed. It is located in the left front corner of the washer.

Thermoactuators

The thermoactuators are a safety device that keeps the door from immediately unlocking if power is lost while the machine is operating. They are mounted above the door locking gear motor.

Lock Thermoactuator

Control voltage is applied to the lock thermoactuator at the beginning of the cycle making it extend and block the door locking gear motor. This keeps the door locked for approximately two minutes after a power failure occurs. The lock thermoactuator does not delay the door opening at the end of a normal cycle.

Unlock Thermoactuator

To insure that the lock thermoactuator has retracted by the end of the cycle, one minute prior to the end of the cycle, the unlock thermoactuator is powered with control voltage making it extend and unblock the door locking gear motor.

Drive Belt Removal

Turn the drive belt(s) off the basket pulley first and then remove from the motor pulley.

NOTE: Reverse this procedure for installation.

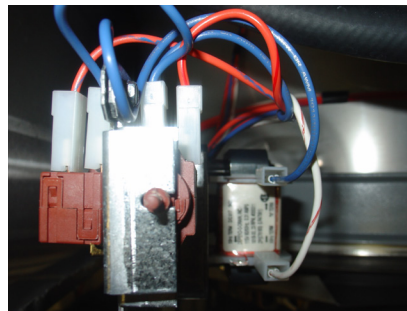
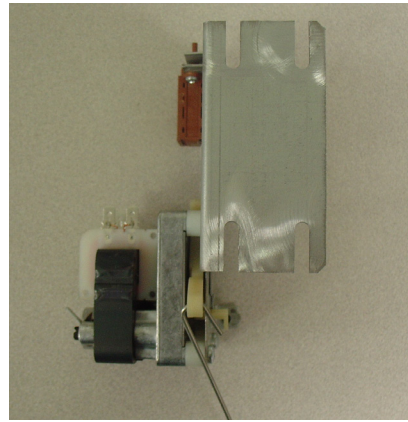

Thermoactuator

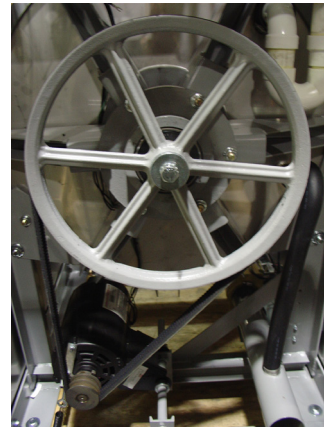

Tub Back, Bearing, and Cylinder Assembly T-600

Removal

- Step 1:** Remove the top and back panel as described.
- Step 2:** Move the rear channel, that the water valves mount to, forward by removing the five mounting screws.
- Step 3:** Remove the drive belt.
- Step 4:** Remove the overflow hose, tub fill hose, and pressure switch hose from the back of the tub.
- Step 5:** Mark the tub back and bearing assembly for ease in assembly later. (see picture)
- Step 6:** Remove the 12 bolts and nuts from the perimeter of the tub back clamp ring. (Two of the twelve bolts are longer and go through the thicker part of the brace where it connects to the frame.)
- Step 7:** Remove the 2 bolts that fasten the clamp ring to the frame.
- Step 8:** The entire tub back and cylinder assembly may be lifted out of the tub (it may be necessary to break the adhesion of the silicone that seals the tub back to the tub). Blocks should be placed under the edges of the cylinder before setting it down to prevent damage to the cylinder flange.

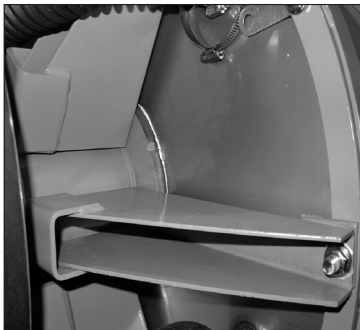

Reassembly:

Reverse the procedures to the left paying attention to the following areas

- Step 1:** Lay the washer on its front. Note: Put a thick pad across the front of the washer, above the door, to protect the handle and coin acceptor.
- Step 2:** Make sure the bearing housing weep holes are located at 12 o'clock and 6 o'clock.
- Step 3:** Clean the silicone rubber from the back of the outer tub and the perimeter of the tub back where the two meet. There is no gasket in this area.
- Step 4:** Apply a new bead of silicone rubber around the back of the outer tub. (see picture)
- Step 5:** Lower the tub back, bearing and cylinder assembly into the washer outer tub.
- Step 6:** Torque all bolts according to the following charts.

Basket Pulley, Bearing Housing, Water Seals, and Tub Back T-600

The cast iron basket pulley is retained by a bolt, locking washer, and a flat washer.

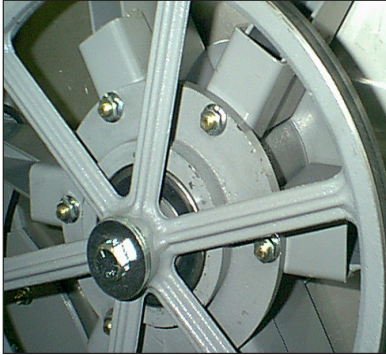

Removal

- Step 1:** Insert a large screw driver or punch through a spoke in the pulley into the bearing housing support. This keeps the pulley from turning.
- Step 2:** Remove the retaining bolt, lockwasher, and flat washer and reinstall just the bolt
- Step 3:** Use a puller to remove the pulley from the shaft. Watch for the tolerance ring.

Reassembly

- Step 1:** Make sure that the tolerance ring is in place inside the pulley.
 - Step 2:** The shoulder inside the pulley that holds the tolerance ring should face the back of the washer when installed correctly.
 - Step 3:** Use a stack of flat washers and a longer bolt to press the pulley onto the basket shaft.
 - Step 4:** Reinstall the retaining bolt, lock washer and flat washer. The shaft end bolt with washer should be installed with a torque value listed in charts in this manual.
-

Removal of Bearing Housing From Basket Shaft, Bearings and Water Seals



- Step 1:** To remove the tub back assembly, the 6 bolts attaching it to the bearing housing must be removed.
- Step 2:** Remove water seals from the seal mounting plate on the cylinder shaft. These are removed with your fingers.
- Step 3:** The retaining ring next to the front bearing must also be removed

Re-installation onto Basket Shaft

- Step 1:** Carefully set the assembly over the shaft engaging the bearings and bearing spacer.
- Step 2:** The tolerance ring that fits inside the pulley should be placed in position (see Basket Pulley Reassembly for correct positioning).
- Step 3:** The pulley should then be started onto the shaft. A stack of flat washers and a longer pulley bolt will be required to pull the basket shaft through the bearings and pulley.
- Step 4:** Install the shaft end bolt with washers and torque to specifications in Bolt Torque Chart.
- Step 5:** See Tub Back, Bearing and Cylinder Assembly for installation of complete assembly back into washer.

Reassembly

Step 1: When installing new bearings into a bearing housing, first press the front (large) bearing into the housing until it bottoms. With the bearing spacer in place, press the rear bearing in until the spacer is snug between the two bearings. Be sure and reinstall the retaining ring in front of the front bearing.



Step 2: The tub back assembly should be reattached to the bearing housing with the 6 mounting bolts and torqued according to the torque chart. **Note: The bead of silicone that seals each bolt to the tub back. This must be cleaned and replaced upon reassembly.**

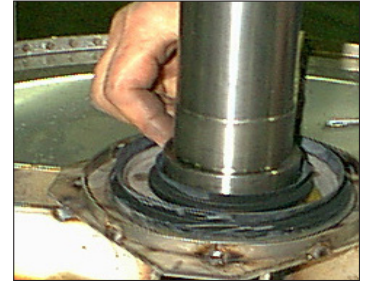

If the 6 support assemblies have been removed from the bearing housing, the 6 rear bearing housing bolts should be torqued according to the chart also.

Step 3: The primary and secondary seals that mount on the sealing ring may be slid over the shaft and seated on the metal sealing ring. In the unlikely event that the metal ring that mounts these sealing rings were to be damaged or moved, a new one would need to be pressed on. The ring must be pushed against the stop on the shaft. Before installing the new sealing ring, a bead of silicone should be put on the basket shaft (see picture). After installing the seals, lubricate the faces of the seals with silicone grease.

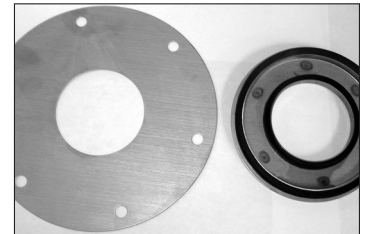

Motor Removal

Step 1: Remove the drive belt as explained in previous instructions.

Step 2: Remove the tension spring and bracket.

Step 3: Disconnect the motor wires in the control area at the top of the machine. The motor wire retaining clamp should be removed and reused. There is a diagram showing where each motor wire plugs in so there is no need to mark them.

Step 4: Loosen the set screws on the motor support shaft.

Step 5: Remove the retaining bolt from the front of the support shaft.

Step 6: Remove the motor support shaft.

Step 7: Lift motor out of machine. Note: On larger washers it is advisable to put a board under the motor and slide it out rather than lifting it.

T-900 and T-1200 Cylinder

- Step 1:** Remove the top panel as described previously.
- Step 2:** Remove lower service panel as described previously.
- Step 3:** Remove front panel as described previously.
- Step 4:** Remove door lock assembly. (Leave wires & pull rod in place)
- Step 5:** Remove clothes door.
- Step 6:** Remove tub front clamp ring.
- Step 7:** Remove tub front. Use a flat screw driver to pry the tub front loose.
- Step 8:** Remove the rear access panel.
- Step 9:** Remove the drive belts.
- Step 10:** Remove drive pulley. Remove 3 retaining screws. Insert (3) 3/8 16 x 2" screws into the threaded removal holes. Alternately tighten these screws evenly to pull the pulley off.
- Step 11:** Remove pulley hub. Drive a flat screw driver into the slot in the hub and pull it from the shaft.
- Step 12:** Install cylinder puller. (Snap On part #CJ-84-C) Be sure to thread a 5/8-11 NC bolt into the end of the cylinder shaft to protect the threads. Push the basket out.

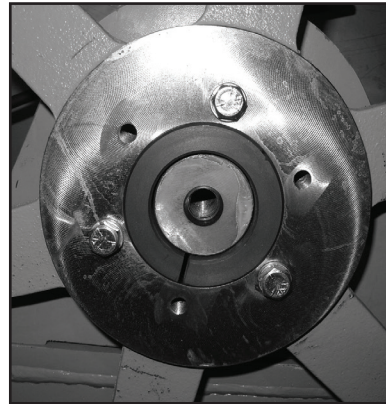
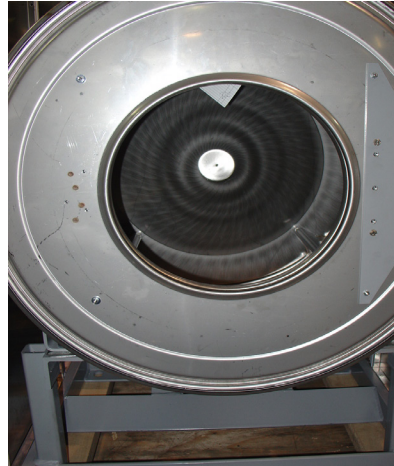

Bearing Housing Assembly T-900 and T-1200

Removal

- Step 1: Remove cylinder from washer (see Cylinder (basket) removal).
- Step 2: Remove 6 7/16" tub back to bearing housing cap screws.
- Step 3: Remove 6 3/4" bearing housing to frame bolts.
- Step 4: Remove bearing housing from frame.
- Step 5: Remove the retaining ring next to the front bearing.
- Step 6: The bearings are pressed into the housing and must be pressed back out.

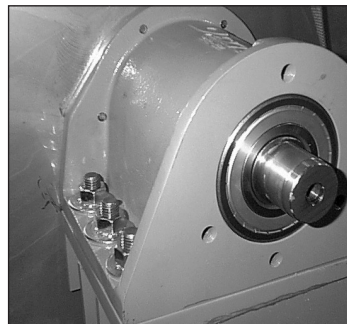

Reassembly

- Step 1:** When installing new bearings into a bearing housing, first press the front (large) bearing into the housing until it bottoms and install the snap ring. With the bearing spacer in place, press the rear bearing in until the spacer is snug between the two bearings.

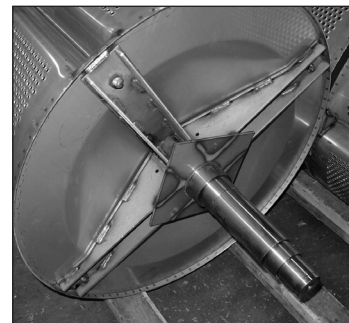

NOTE: If the tub-back water-seal mating ring has been moved it must be cleaned and re-sealed

T-900 and T-1200 Water Seals

Replacement

- Step 1:** Remove cylinder from washer (see Cylinder (basket) removal).
- Step 2:** Remove water seals from the seal mounting plate on the cylinder shaft. These are removed with your fingers.
- Step 3:** The primary and secondary seals that mount on the sealing ring may be slid over the shaft and seated on the metal sealing ring with your fingers. In the unlikely event that the metal ring that mounts these sealing rings were to be damaged or moved, a new one would need to be pressed on. The seal mounting ring must be pushed against the stop on the shaft. After installing the seals, lubricate the faces of the seals with silicone grease.
- Step 4:** Install cylinder (see Cylinder (basket) reassembly).



Guard Ring & Mating Ring

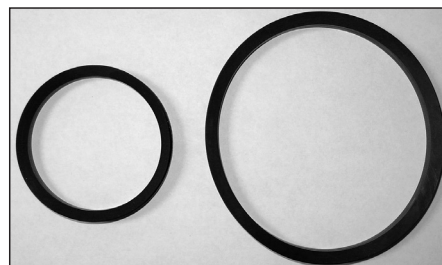

Seals

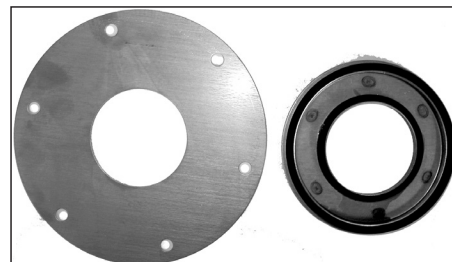

Mating Ring & Mounting Ring

Outer Tub T-900 and T-1200

Removal

- Step 1:** The outer tub can easily be removed when the tub front, cylinder and bearing housing has been removed as outlined previously.
- Step 2:** At that point the only attachments to the chassis are the two front strap mounting bolts.

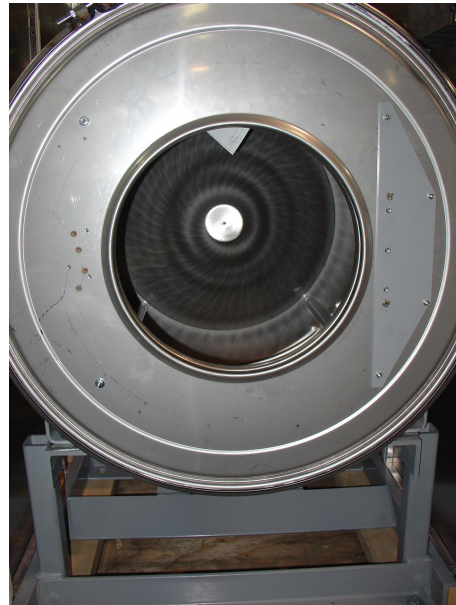

Reassembly T-900 and T-1200 Cylinder

- Step 1:** Use the hub of the drive pulley, a stack of 5/8" flat washers and a 3" long 5/8" bolt to pull the cylinder shaft through the bearings. After the 3" bolt a 2" long bolt will be required to finish pulling the cylinder shaft through.
- Step 2:** Remove the 1/2" bolt and nut from the top of the outer tub clamping band.
- Step 3:** Install Dexter Tool part # 8545-056-001 on the back of the outer tub to adjust tub front to cylinder clearance. Thread 5/8" bolt through tool and into cylinder shaft. Push the outer tub forward 1/4" to 1/2" with tool 8545-056-001 by tightening the 5/8" bolt. This will ease the installation of the outer tub front.
- Step 4:** Clean the silicone rubber off the tub front and the outer tub.
- Step 5:** Install new bead of silicone rubber on tub front.
- Step 6:** Install tub front.
- Step 6A:** Align hole in top of tub front with notch in top of outer tub.
- Step 6B:** Use 4-6 #11R vise grip clamps to hold tub front to outer tub. A rubber mallet may be needed to properly seat the tub front into the outer tub.
- Step 6C:** Install tub front gasket around outer edge of tub front and outer tub flange. The opening should be centered at the top.
- Step 6D:** Remove vise grips. The tub front gasket will hold the tub front in place.
- Step 7:** Install tub front clamp ring and tighten. Tap around the clamp ring with a rubber mallet to seat the ring and gasket while tightening the clamp ring bolt.
- Step 8:** Adjust clearance between the outer tub front and the front lip of the cylinder to 5/16".
- Step 9:** Tighten the outer tub clamping band.

Step 10: If necessary, the outer tub may be adjusted up or down and side to side with the 2 bolts that fasten the bottom of the outer tub clamping band to the frame.

Step 11: Remove Dexter Tool part # 8545-056-001 from the back of the outer tub.

Step 12: Install drive pulley.

Step 12A: Install hub on cylinder shaft.

Step 12B: Hold hub against rear bearing with 5/8" bolt and flat washer in end of cylinder shaft.

Step 12C: Line up 3 unthreaded holes in pulley with the 3 threaded holes in hub.

Step 12D: Insert 3 pulley bolts and tighten evenly alternating bolts to 30ft/lbs.

NOTE: Overtightening or uneven tightening can break drive pulley.

Step 13: Install drive belts & back panel.

Step 14: Install door lock. All mounting holes should be sealed with silicone rubber.

Step 15: Install door, front panel, lower service panel and top.

T-600 Bolt Torque Chart		
Bolt Size	Where Used	Torque
1/2"x 1 1/4" bolt	Tub End of Bearing Hsing. 9545-017-009	70-110 ft/lbs
5/8"x 1 1/2" bolt	Tub End of Bearing Hsing. 9545-060-001	120-150 ft/lbs
1/2"x 1 1/4" bolt	Mtg. of Tub to Cradle Asy. 9545-017-009	70-110 ft/lbs
5/8"x 2 1/2" bolt	Mtg. of Tub to Cradle Asy. 9545-060-001	120-150 ft/lbs
3/8"x 1 1/2" bolt	Tub Back Ring to Tub Back 9545-029-003	45-80 ft/lbs

T-900 & T-1200 Bolt Torque Chart		
Bolt Size	Where Used	Torque
7/16" Stainless Cap Screw	Outer Tub to Bearing Housing	60-80 ft/lbs
3/4" Bolt	Bearing Housing to Frame	200-300 ft/lbs
1/2" Bolt	Outer Tub Clamping Band to Frame	70-110 ft/lbs
1/2" Bolt	Outer Tub Clamping Band - Top	30-40 ft/lbs
3/8" Cap Bolt	Drive Pulley to Hub	30 ft/lbs

Microprocessor, also called a CPU

The microprocessor is mounted vertically on the right side of the control trough. It controls all washer functions and is held in place with 4 screws. There are 4 wiring connectors on the board for incoming and outgoing signals. See Microprocessor drawing below for exact locations.

The single red light on the board shows if the microprocessor has power and if it is processing data. As shown in the drawing below, the light should be on steady any time the washer has power to it.

If the red light is flashing, the microprocessor has stopped processing data. Remove power from the machine for 2 minutes to reset board. Repower the washer and check the light to see if it is on steady.

If the light is off, there is no power to the board

Control Mounting Trough

Remove top panel to access control trough. (see Removing Top Panel) It sets on the right side of the machine and holds the control PCB's, transformers and pressure switch.

Circuit Breaker/Fuse

The fuse (optional circuit breaker) mounts to the rear channel. It carries all of the controls in the machine but does not include the motor. To reset the circuit breaker just push in the button. If you have a fuse then remove fuseholder and fuse and replace with a 1 1/2 amp fast blow type fuse.

PCB Transformer Step-down 120/12

Small transformer mounted at front of control trough that has primary power of 120VAC and secondary outputs of 12VAC

Main Controls Transformer 208-240/120

This transformer is mounted at the back of the control trough and range of 208 to 240 volts down to 120 volts for the controls. There are two terminals on the controls transformer for incoming power. All washers have a controls transformer. Always check the incoming and use the appropriate transformer terminal when installing ALL

Main Relay Input/Output-Printed Circuit Board

Please be sure to be grounded to machine before removal of board. PCB mounting horizontal in control trough towards front of Remove 4 mounting nuts.

Display LED Printed Circuit Board

The selector switch is mounted in the center of the control panel and is held in place with five nuts. It allows the selection of hot, warm, or cold water temperatures. **Note:** Do not over tighten on reinstallation as the switch can be damaged, stay pushed in and will cause erratic display

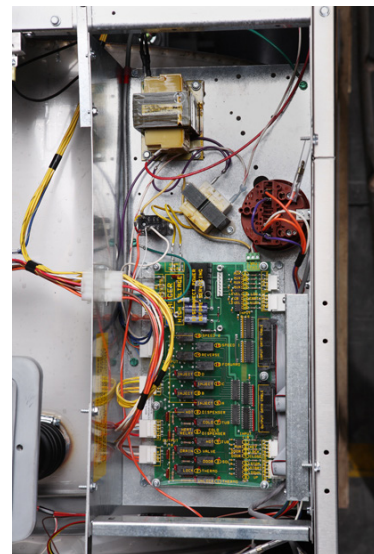

steps a

Note:
voltage
washers.

this
machine.

Pressure Switch :Caution (Not recommended by Factory!) Changing Factory preset adjustment voids all factory water usage specifications.

The pressure switch sets the water level in the washer. As the water level rises, it compresses the air in the pressure switch hose. When the washer reaches the desired water level, the compressed air in the pressure switch hose opens the contacts in the switch, shutting off the water. When at the empty level, the pressure switch contacts are closed allowing the machine to either spin or fill with water. The 1/4" screw in the middle of the switch adjusts the water level. Turning it clockwise 1/8 of a turn will raise the water level 1/4 of an inch. Counter clockwise will lower the water level. Before making any adjustments of the pressure switch, drain the tub and blow the hose clear of possible water bubbles which can cause erratic pressure switch operation. With no load, the water level should be approximately at the bottom to 1/2" to 1" up from the bottom of the glass on ALL models.

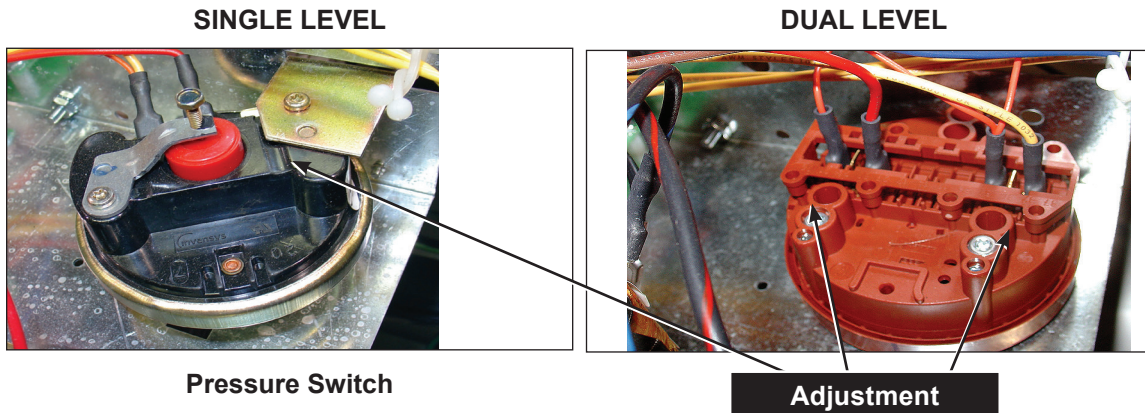

Mechanical Pressure switch VS Pressure Sensor

The Drawing below represents the Mechanical Pressure switch and wiring connections. After serial number W1.15244.001 all washers were converted to the electronic pressure sensor 9732-315-001. If desired previous C-series machines can be upgraded to the electronic pressure sensor with Kit 9732-314-001, Kit includes pressure sensor, hold downs, transformer, and wires. The Electronic pressure sensor wiring configuration is represented in the Diagrams and Schematics in this manual.

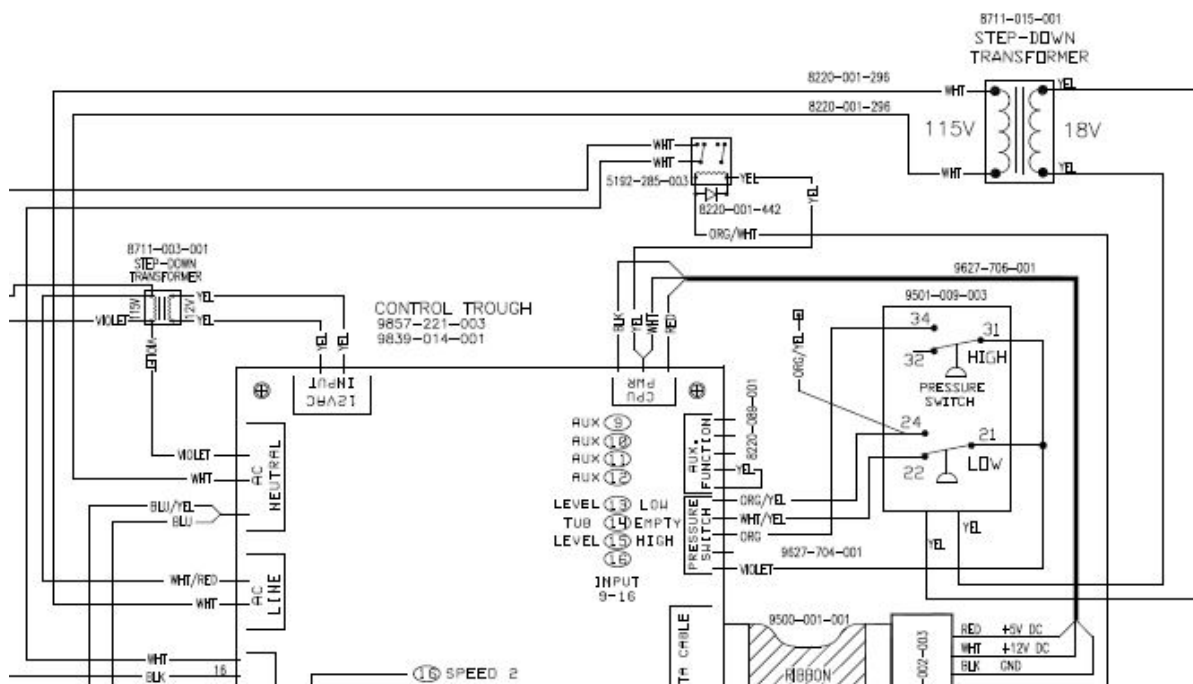

Electronic Pressure Sensor

The Electronic Pressure Sensor comes standard on all models Starting Septembet, 1st 2015. Machines manufactured before this date can be upgraded with Kit 9732-213-001. The Pressure sensor is adjustable. The Factory settings chart will let you know the starting values for each machine and by following the Switch position chart you can adjust the water levels in 1/4 inch increments from that starting value.

Factory Settings:



Model	Vended		On-Premise	
	Switch #1 Efficient	Switch #2 Classic	Switch #1 Low Level	Switch #2 High Level
T-300	5.25	7.00	6.00	6.75
T-350	5.25	6.25	6.00	6.75
T-400	7.00	9.00	8.00	11.00
T-450	6.00	6.25	6.00	8.50
T-450 SWD	5.00	7.00	6.00	8.50
T-600	7.25	9.25	8.00	11.00
T-650	6.50	8.25	8.00	11.00
T-750	6.00	7.50	6.00	8.75
T-900	6.00	7.50	6.00	8.75
T-950	6.00	7.50	6.00	8.75
T-1200	6.00	7.50	6.00	8.75
T-1450	6.75	7.00	6.75	9.50

Switch Positions:

Depth (in):	Pos 1	Pos 2	Pos 3	Pos 4	Pos 5	Pos 6
5.00						
5.25	on					
5.50		on				
5.75	on	on				
6.00			on			
6.25	on		on			
6.50		on	on			
6.75	on	on	on			
7.00				on		
7.25	on			on		
7.50		on		on		
7.75	on	on		on		
8.00			on	on		
8.25	on		on	on		
8.50		on	on	on		
8.75	on	on	on	on		
9.00					on	
9.25	on				on	
9.50		on			on	
9.75	on	on			on	
10.00			on		on	
10.25	on		on		on	
10.50		on	on		on	
10.75	on	on	on		on	
11.00				on	on	
11.25	on			on	on	
11.50		on		on	on	
11.75	on	on		on	on	
12.00			on	on	on	
12.25	on		on	on	on	
12.50		on	on	on	on	
12.75	on	on	on	on	on	
13.00						on
13.25	on					on
13.50		on				on
13.75	on	on				on
14.00			on			on
14.25	on		on			on
14.50		on	on			on
14.75	on	on	on			on
15.00				on		on

Power Connection Terminal Block

This terminal block sets at the very back of the control trough. Incoming power to the washer should connect here. (see Electrical under Installation and Operation Section for exact connections)

Delta Variable Frequency Drive:

Main power is connected to terminals L1, L2, and L3 on the Delta drive. If the washer is connected to a three phase source, there should be voltage present on all three terminals. If the washer is connected to single phase power, there should be voltage present on terminals.

The voltage should measure 208 Volts to 240 VAC between phases and connected to if connected to three phase). There is a tolerance of +/- 10% on the main voltage (187 Volts to 264 Volts).

Delta VFD Motor Leads:

The wires from the motor are connected to terminals T1, T2, and T3. Since this drive uses pulse width modulation, an accurate current or voltage reading is not possible. Although an accurate current reading is not possible, a balanced current reading should be present while the motor is running.

Delta VFD Dynamic Braking Resistors:

Two, 160 Ohm or 200 Ohm braking resistors (Please check your washer model parts requirements and quantities), are connected in parallel and attached to the drive at terminals B1 and B2. These resistors allow voltage, which is generated by the motor when decelerating, to be dissipated. They will become hot while the motor is slowing down, so care should be taken so as not to come in contact with them. This will prevent an electrical shock and/or a physical burn.

Delta VFD Cooling Fan:

There is a cooling fan attached to the bottom of the Delta drive. This fan will operate when the internal temperature of the drive reaches a predetermined level, the same way the radiator fan in a newer car operates. **THE FAN CAN OPERATE ANYTIME POWER IS APPLIED TO THE DRIVE!** Remove power to the drive if work is required around the fan.

MAXIMUM SPIN SPEED ADJUSTMENT:

If desired, the washer can be adjusted to limit the maximum extract spin speed for all wash cycles. To make this adjustment, a jumper wire must either be installed or removed on the Variable Frequency Drive (VFD), depending on the washer model and desired speed. This Dexter jumper part number 8220-057-036 (qty. 1) is factory supplied on terminal points "10V" and "RC". Remove this jumper to make new jumper connections if necessary. Refer to Error! Reference source not found. for the approximate location of the control terminations on the Variable Frequency Drive (VFD) and Error! Reference source not found. for appropriate jumper connection points indicated with an "X" for the desired maximum spin speed setting. If no adjustment to default spin speed is desired, do not remove or add any wires on VFD.

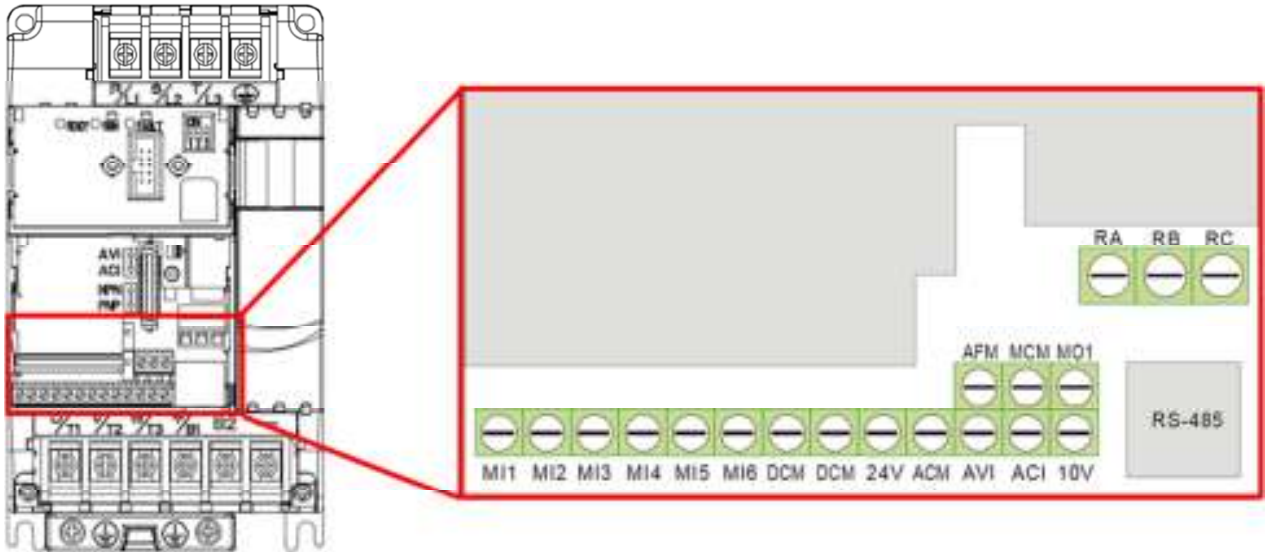

N Series Washer Model	Max Spin Speed	Jumper Terminal Locations on Variable Frequency Drive (VFD)													
		MI1	MI2	MI3	MI4	MI5	MI6	DCM (Left)	DCM (Right)	24V	ACM	AVI	ACI	10V	MO1
T-600, T-900, T-1200	60 G												X		X
	80 G						X		X						
	100 G	Default Setting (No Jumper Required)													
T-650, T-950, T-1450	100 G											X		X	
	140 G	REMOVE Brown Jumper between MI6/MO1													
	200 G	Default Setting (With Factory Installed Brown Jumper)													

Table 2: Spin Speed Adjustment Jumper Locations

Drive Motor Inverter Type Motor-Winding Resistance Chart

40lb Series Washer

Motor	Winding	Wire #	Resistance	
			Minimum	Maximum
40lb 1ph or 3ph 60hzMain (wash & spin)		T1 & T2	2.45	2.71
Dexter #9376-305-001		T2 & T3	2.45	2.71
A.O. Smith #19343600		T1 & T3	2.45	2.71

60lb & 80lb Series Washer

Motor	Winding	Wire #	Resistance	
			Minimum	Maximum
60lb 1ph or 3ph 60hzMain (wash & spin)		T1 & T2	2.4	2.8
#9376-308-001	Marathon	T2 & T3	2.4	2.8
		T1 & T3	2.4	2.8

NOTE: Resistance values are measured at the stator. Values at the end of the motor wiring harness may be slightly higher.



Section 6:

Parts data for the following models:

	Model	HZ	Phase	Voltage	Heat Option	G's
9999-662-001	WN0600XA-12EN2X-SSKCS-USX	60	1 - 3ph	208 - 240v		100
9999-662-003	WN0600EA-13EN2X-SSKCS-USX	60	3ph	208 - 240v	Heated Electric	100
9999-665-001	WN0900XA-12EN2X-SSKCS-USX	60	1 - 3ph	208 - 240v		100
9999-665-003	WN0900EA-13EN2X-SSKCS-USX	60	3ph	208 - 240v	Heated Electric	100
9999-669-001	WN1200XA-12EN2X-SSKCS-USX	60	1 - 3ph	208 - 240v		100
9999-669-003	WN1200EA-13EN2X-SSKCS-USX	60	3ph	208 - 240v	Heated Electric	100
	Model	HZ	Phase	Voltage	Heat Option	G's
9999-662-002	WN0600XA-39XN2X-SSKCS-VRX	50	1ph	230 - 240v		100
9999-662-004	WN0600EA-68XN2X-SSKCS-VRX	50	3ph	400v	Heated Electric	100
9999-662-005	WN0600FA-59CN2X-SSKCS-VRX	50	1ph	230		100
9999-665-002	WN0900XA-39XN2X-SSKCS-VRX	50	1ph	230 - 240v		100
9999-665-004	WN0900EA-68XN2X-SSKCS-VRX	50	3ph	400v	Heated Electric	100
9999-669-002	WN1200XA-39XN2X-SSKCS-VRX	50	1ph	230 - 240v		100
9999-669-004	WN1200EA-68XN2X-SSKCS-VRX	50	3ph	400v	Heated Electric	100

Washer Accessories

Key	Description	T-600	T-900	T-1200	QTY
*	Hose, Water Supply 5/8" I.D. x 48"	9990-027-013	9990-027-013	9990-027-013	2
*	Washer, Inlet Hose (furnished)	8641-242-000	8641-242-000		2
*	Strainer, Inlet Hose (furnished)	9565-003-001	9565-003-001		2
	Hose, Water Supply 5/8" I.D. x 48"			9990-027-013	4
	Washer, Inlet Hose (furnished)			8641-242-000	4
	Strainer, Inlet Hose (furnished)			9565-003-001	4
*	Bevel Washer for 5/8" bolt used in installations using angle iron bases	8641-586-002	8641-586-002	8641-586-002	
*	Bevel Washer for 3/4" bolt used in installations using angle iron bases	8641-586-003	8641-586-003	8641-586-003	
*	Sealing compound	8538-151-002	8538-151-002	8538-151-002	
*	Flow Restrictors (in dispenser)	9475-002-002	9475-002-002		2
	Flow Restrictors (in dispenser)			9475-002-003	3
*	Special Tool for adjusting spacing between outer tub front and cylinder front		8545-056-001	8545-056-001	
*	VFD Filter options (3 phase)	9732-231-001	9732-255-001	9732-256-001	
*	VFD Filter options (1 phase)	9732-232-001	9732-230-001	9732-251-001	
*	Puller for pushing cylinder out of bearings must be purchased from local sources.				
*	Clamps to hold tub front to outer tub when installing tub front		Vise Grip #11R	Vise Grip #11R	
*	OPL Bearing & Seal Kit	9732-219-005	9732-219-007	9732-219-007	
*	USB Thumb Drive	9150-045-002	9150-045-002	9150-045-002	
*	Informative	6102-018-235	6102-018-237	6102-018-240	

Wiring Harness Group

Key	Description	T-600	T-900	T-1200	QTY
*	Wiring Diagram,	9506-759-001	9506-763-001	9506-771-001	1
	Wire Hrnss from Door lock Assy	9627-837-001	9627-891-001	9627-891-001	1
*	Wire Hrnss,Door Lock CPU	9627-891-001	9627-892-001	9627-892-001	1
*	Wire Hrnss Power Terminal Block	9627-747-003	9627-747-003	9627-747-002	1
*	Wire Hrnss,to Drn,Thermo,DorSol	9627-893-001		9627-796-002	1
*	Wire Hrnss,Trough	9627-697-001	9627-697-001	9627-697-001	1
*	Wire Hrnss CPU to I/O board	9627-706-001	9627-706-001	9627-706-001	1
*	Wire Hrnss Control VFD	9627-811-002	9627-811-001	9627-811-001	1
*	Wire Hrnss CPU to Display	9627-705-001	9627-705-001	9627-705-001	1
*	Wire Hrnss Control-VF-Shield	9627-810-001	9627-810-001	9627-810-001	1
*	Wire Hrnss Pressure Switch	9627-704-001	9627-704-001	9627-704-001	1
*	Wire Hrnss Membrane Switch	9627-700-001	9627-700-001	9627-700-001	1
*	Wire Hrnss 120VAC	9627-893-001	9627-893-001	9627-894-001	1
*	Wiring Assembly Diode	8220-001-442	8220-001-442	8220-001-442	1
*	Wiring Assembly Red 8"			8220-108-009	1
*	Wiring Assembly Wht/Brn 8"			8220-108-007	1
*	Wire Jumper White/Red	8220-090-001	8220-090-001	8220-090-001	1
*	Wire Yellow Jumper (Violet)	8220-090-010	8220-090-010	8220-090-010	1
*	Wiring Assembly Red 28"	8220-062-025	8220-062-025	8220-062-025	1
*	Wiring Assembly Dor Csl Red 23"		8220-063-028	8220-063-028	2
*	Wire Assy Jumper BLK.(brk resit)	8220-117-002	8220-117-002	8220-117-002	2
*	Wiring Assembly	9631-381-018	9631-381-018	9631-381-018	1
*	Wiring Assembly	8220-090-009	8220-090-009	8220-090-009	1
*	Wiring Assembly	8220-001-231	8220-001-231	8220-001-231	1
*	Wire Red 20"		8220-001-282	8220-001-282	1
	Ribbon Cables	9500-001-001	9500-001-001	9500-001-001	2
*	Wire Yellow Jumper (water valve)	8220-123-001	8220-123-001	8220-119-002	1
	Wiring Assembly Dor Csl blk 23"		8220-063-029		2
	Wire-White 11 1/2"	8220-001-296	8220-001-296	8220-001-296	2
	Wire-White 3"	8220-057-036	8220-057-036	8220-057-036	1
*	Wiring Assembly - White/Red	8220-001-371			
	Wiring Assembly - Red	8220-001-372			
	Wiring Assembly - Red 17"	8220-063-025			

Labels and Diagrams All 30 cycle Models

Key	Description	T-600	T-900	T-1200	QTY
*	Transient Voltage Surge Suppressor Infomational	8507-330-001	8507-330-001	8507-330-001	
*	Inst. Spin Direction	8507-274-001	8507-275-001	8507-275-001	1
*	Inst. Chemical Hose	8507-268-001	8507-268-001	8507-268-001	1
*	Injector Connections Label	8502-647-002	8502-647-002	8502-647-002	1
*	Wiring Schematic/Diagram	9506-759-001	9506-763-001	9506-771-001	1
*	Label for Electrical Connections	8502-649-001	8502-649-001	8502-649-001	1
*	Label High Voltage Warning	8502-614-004	8502-614-004	8502-614-004	1
*	Label Fusing & Installation	8502-619-004	8502-619-003	8502-619-003	1
*	Label Quality	8511-001-002	8511-001-002	8511-001-002	1
1	Label Warning Risk of Injury (Black)	8507-759-001	8507-759-001	8507-759-001	1
2	Label Warning Door Opening (Black)	8502-757-001	8502-757-001	8502-757-001	1
*	Booklet Owners	8514-241-001	8514-244-001	8514-246-001	1
3	Label Top Dispenser (Black)			8502-745-001	1
*	Injector Label Assembly	8502-666-001	8502-666-001	8502-666-001	1
*	Dispenser Instructions	8502-650-001	8502-650-001		1
*	Installer Installation Instruction	8502-653-001	8502-653-001	8502-653-001	1
*	Inst. Control Transformer	8507-449-001	8507-449-001	8507-449-001	1
*	Inst. Connection Transformer	8507-230-001	8507-230-001	8507-230-001	1
*	Inst. Washer Install	8507-448-001	8507-448-001	8507-448-001	1



Door Label



Risk of Injury Label



Top Dispenser Label T-1200

Control Panel Part # by Model

Key	Description	T-600	T-900	T-1200	QTY
1	Panel Control Assembly(panel only)	9989-463-001	9989-456-001	9989-456-001	1
*	Screw, Hxwshrhdundct #10Bx 1/2" Mtg Control Panel	9545-008-026	9545-008-026	9545-008-026	4
*	Post Locator Top	9467-024-001	9467-024-001	9467-024-001	2
*	Nut Hexkeps #6-32	8640-411-003	8640-411-003	8640-411-003	2
*	Locator Panel	9355-001-001	9355-001-001	9355-001-001	2
*	Screw FillHDCR 10Bx1/2" Guide	9545-008-023	9545-008-023	9545-008-023	2
*	Plate-Latch Top	9452-625-001	9452-625-001	9452-625-001	2
*	8-32 Nut for Plate-Latch&Membrane	8640-412-005	8640-412-005	8640-412-005	7
*	Nut Hexelasticstop #4-40	8640-424-002			2
2	Membran Switch assy (Black)	9801-061-002	9801-061-002	9801-061-002	
*	Plate Membrane switch Assy	9452-637-001	9452-637-001	9452-637-001	1
3	PCB Display	9799-001-001	9799-001-001	9799-001-001	1
*	Nut 8-32 for display	8640-412-005	8640-412-005	8640-412-005	4
4	Lock-Run/Program Switch w harness & Key	8650-028-001	8650-028-001	8650-028-001	1
5	Harness, CPU to Display	9627-705-001	9627-705-001	9627-705-001	1
	Harness, Membrane Switch	9627-700-001	9627-700-001	9627-700-001	1
6	Nameplate,Control Panel (one piece) (Black)	9412-222-001	9412-226-001	9412-190-001	1
*	Hex Nuts (mounting Door Lock assy. to control panel)	8640-412-005	8640-412-005	8640-412-005	4
7	Catch, Top Panel	9086-017-001	9086-017-001	9086-017-001	2

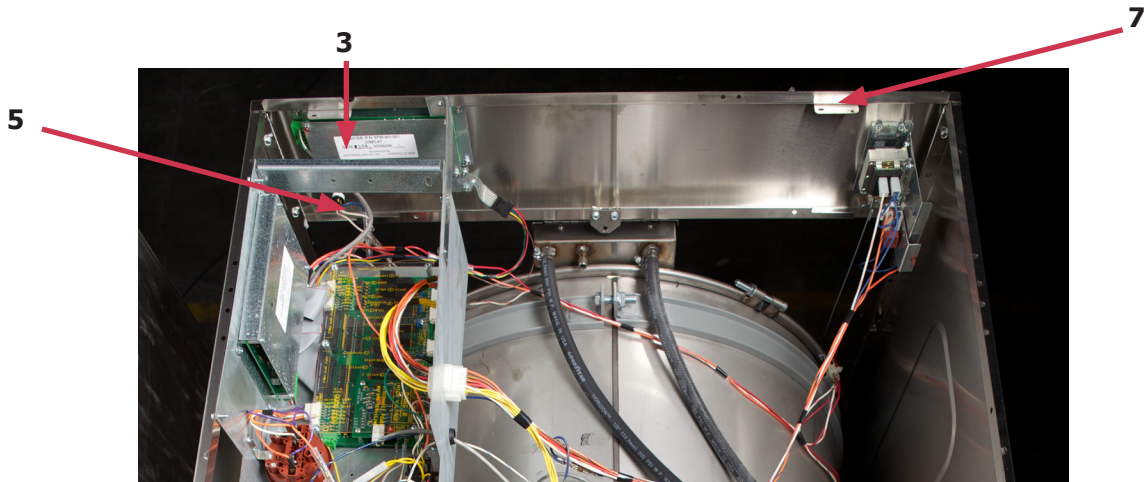

Cabinet and Front Panel Group

Key	Description	T-600	T-900	T-1200	QTY
1	Panel, Side (Left or Right) - stainless	9732-359-008			2
1	Panel, Side (Left or Right) - stainless		9732-359-002	9732-359-003	4
*	Screw, (Side Panel to Base)	9545-018-013	9545-018-013	9545-018-013	8
*	Nut, Hex 1/4-20 UNC	8640-414-006	8640-414-006	8640-414-006	8
*	Strap Assembly Side Panel		9966-012-001	9966-012-002	4
*	Nuts, strap to side panel & brace		8640-414-006	8640-414-006	8
*	Bracket brace, Side Panel under front panel	9029-263-001	9046-085-001	9046-085-001	1
*	Nut, Hex	8640-413-002			2
*	Screw	9545-008-026	9545-008-026		1
*	Foam Pad damper	0904-904-001			2
2	Panel, Control (Mounts Nameplate)	9989-463-001	9989-456-001	9989-456-001	1
*	Screw, Control Panel to Side Panel	9545-008-026	9545-008-026	9545-008-026	4
3	Nameplate Decal, Control Panel Black	9412-222-001	9412-226-001	9412-229-001	1
4	Membrane Switch Black	9801-061-002	9801-061-002	9801-061-002	1
*	Screw, Hex- Control to Front Panel	9545-008-024	9545-008-024	9545-008-024	2
*	Nut, Spring- Control to Front Panel 10/32	8640-442-001	8640-442-001	8640-442-001	2
5	Panel Assy, Front	9454-895-002	9989-617-003	9989-618-003	1
*	Screw Front Panel Mtg.	9545-008-023	9545-008-024	9545-008-024	2
*	Flat Washer #10	8641-585-001	8641-585-001	8641-585-001	2
*	Spring Nut	8640-442-001	8640-442-001	8640-442-001	5
*	Band, Edge Protector Trim	9578-092-005	9578-092-005	9578-092-005	1
6	Bumper Loading Door	9051-055-001	9051-055-001	9051-055-001	1
*	Nut, Bumper Hold	8640-414-003	8640-414-003	8640-414-003	1
7	Screw, Flat Head- Front to Sides	9545-008-014	9545-008-014	9545-008-014	2
8	Washer, Finish (Front Panel)	8641-585-001	8641-585-001	8641-585-001	2
*	Nut, Spring-To Front Panel	8640-442-001	8640-442-001	8640-442-001	2
9	Label, Door Opening Black	8502-757-001	8502-757-001	8502-757-001	1
10	Label, Warning, Risk of Injury Black	8507-759-001	8507-759-001	8507-759-001	1
11	Panel Top	9454-735-001	9454-736-001		1
11	Panel Top Front			9454-761-001	1
11	Panel Top Rear			9454-762-001	1
12	Lock, Top (w/Key)	8650-012-003			1
12	Lock, Top (w/Key)		8650-012-003	8650-012-003	2
*	Cam, Top Lock each	9095-049-001	9095-049-001	9095-049-001	1
*	Cam Nut 9/32 - 28 Hex each	8640-426-001	8640-426-001	8640-426-001	1
*	Washer Flat 5/16	8641-581-008	8641-581-008	8641-581-008	1
13	Door, Lower Service(w/Handle)	9960-286-002	9960-286-004	9960-286-004	1
14	Handle (bumper guard)	9244-086-002	9244-086-003	9244-086-003	1
*	Rivet	9491-009-003	9491-009-003	9491-009-003	4
15	Screw Mtg., Flat Head	9545-008-014	9545-008-014	9545-008-014	2
*	Nut, Spring	8640-442-001	8640-442-001	8640-442-001	2
16	Washer, Finish (Front Panel)	8641-585-001	8641-585-001	8641-585-001	2

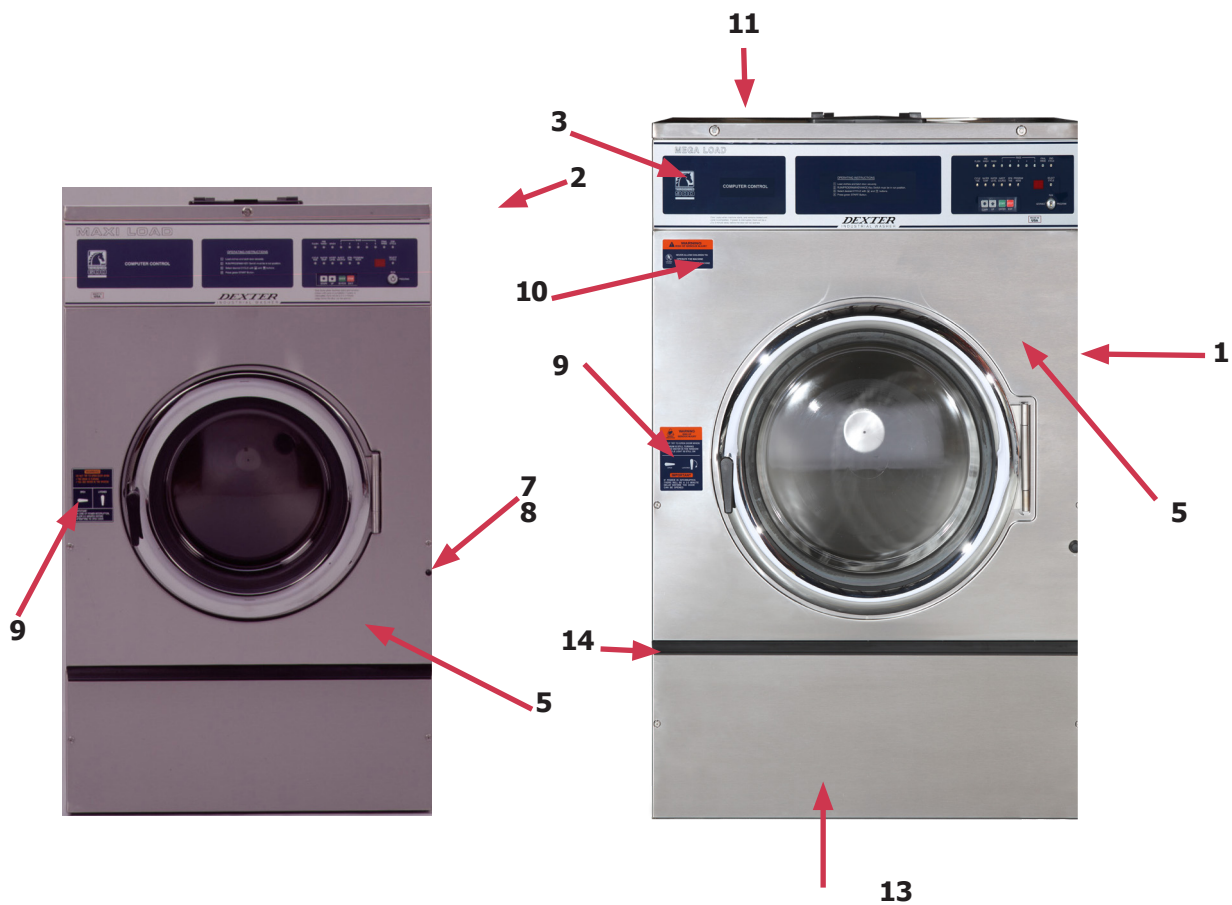

Cabinet and Front Panel Group Part # by Model

Front Soap Dish

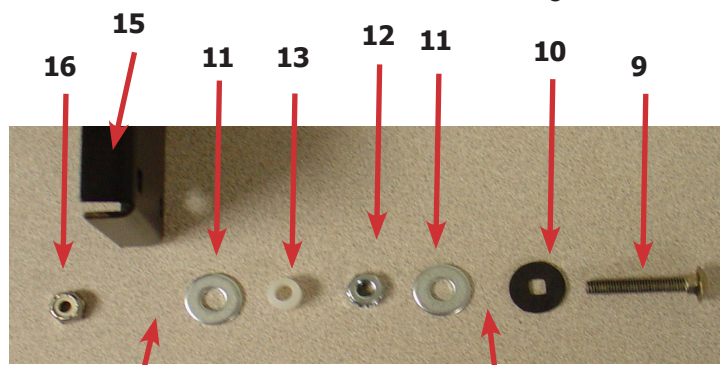
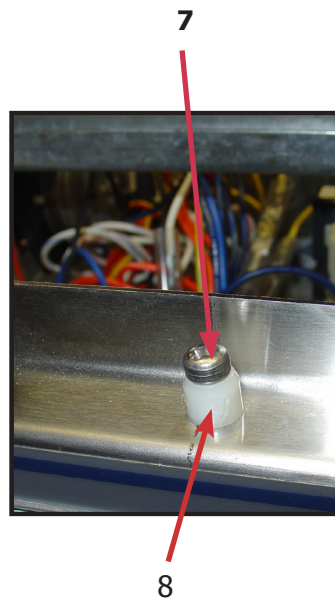
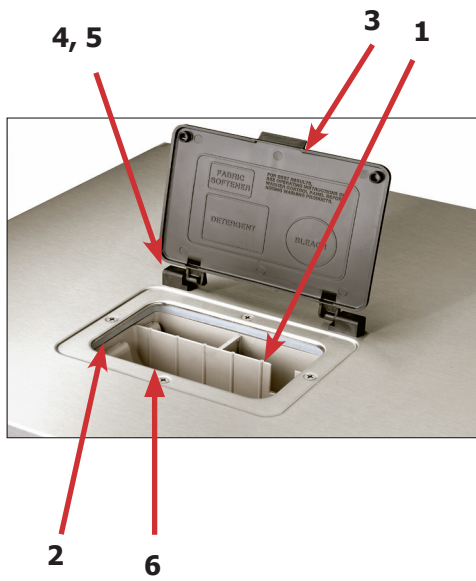

Gasket and Soap Dish Here

Tub Front Here

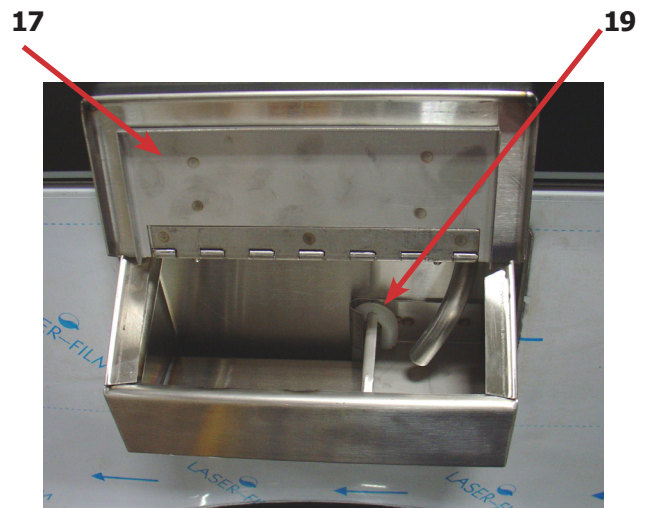
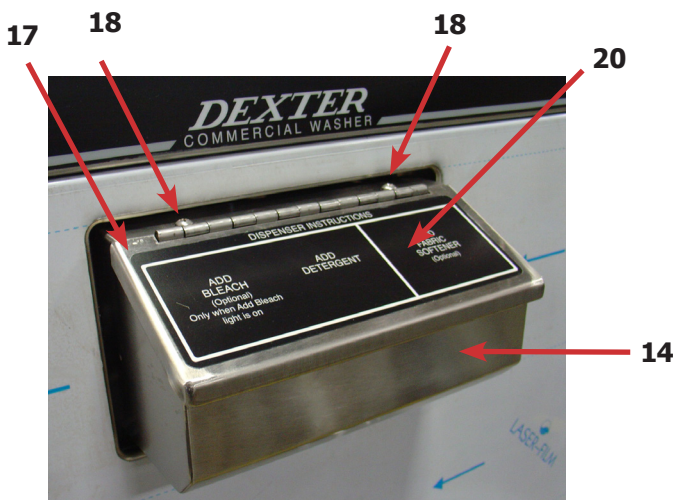

Top Mount Detergent Dispenser

Key	Description	T-600	T-900	T-1200	QTY
1	Dispenser Soap	9122-005-004	9122-005-004		1
2	Gasket Dispenser	9206-416-001	9206-416-001		1
*	Hose, Dispenser to tub	9242-450-001	9242-450-001		1
*	Clamp	8654-117-008	8654-117-008		2
*	Nut, Spring ss	8640-399-007	8640-399-007		4
*	Flow restrictors	9475-002-002	9475-002-002		2
*	Flow restrictors Optional (Smaller)	9475-002-003	9475-002-003		2
3	Door, Dispenser	9108-095-005	9108-095-005		1
4	Pin, Plain	9451-191-001	9451-191-001		2
*	Post, Door Mounting	9467-025-001	9467-025-001		2
6	Screw- 8B x 1/2	9545-045-002	9545-045-002		4
	Screw, SS Dispenser, 10B x 1	9545-008-012	9545-008-012		4
*	Washer Flat 5/16	8641-581-008	8641-581-008	8641-581-008	1
7	Screw, Locator	9545-008-023	9545-008-023	9545-008-023	1
8	Plastic Sleeve, Locator	9355-001-001	9355-001-001	9355-001-001	1
*	Catch, Top Panel	9086-017-001	9086-017-001	9086-017-001	2
	Lock, Top (w/Key)	8650-012-003			1
*	Lock, Top (w/Key)		8650-012-003	8650-012-003	2

Front Mount Detergent Dispenser

Key	Description	T-600	T-900	T-1200	QTY
9	Bolt,#10-32 x 1 1/4"SS			9545-012-026	6
10	Special Washer, Rubber			8641-242-000	4
*	Tub Front			9178-048-002	1
11	Washer-Flat, 1/4			8641-581-018	4
12	Nut, #10-32UNF			8640-413-002	6
13	Spacer Plastic #10x1/2			9538-157-019	6
14	Soap Dispenser (no lid)			9807-087-001	1
*	Det. Dispenser Mtg Gasket to Tub frnt			9206-425-001	1
15	Bracket Soap box mounting			9029-122-002	1
16	Nut Hex Elasticstop #10-32 SS mtg dispenser			8640-413-006	6
17	Lid Assembly dispenser			9987-104-001	1
18	Lid screws #10-32x1/2 SS			9545-012-017	2
19	Softner siphon tube (plastic)			9574-252-002	1
*	Flow restrictors			9475-002-003	AR
20	Washer Dispenser Label Black			8502-756-001	1
*	Kit-Soap Dish, Replacement (Large Door)			9732-290-001	

Rear View Access Part # by Model T-600

Key	Description	T-600	QTY
1	Drive Motor, 3 Phase (Inverter duty)	9732-127-012	1
2	Pulley, Motor	9453-170-003	1
*	Set Screw,Sq.Hd(motor pulley)	9545-028-015	2
3	Rod, Motor Mtg	9497-222-004	1
*	Screw (end of motor rod)	9545-029-005	1
*	Lockwasher (end of motor rod)	8641-582-014	1
*	Collar, Shaft (w/set screws) removed starting #530726	9076-052-002	2
4	Motor Bushing (Rubber)	9053-082-001	2
5	Clamp-Worm, 316SS, 1.5"	8654-117-019	2
6	Strap Bracket, Motor Tension	9029-206-001	1
*	Nut, Strap to Motor 10/32 UNF	8640-413-002	1
*	Washer #10	8641-581-006	1
7	Spring, Belt Tension	9534-319-002	1
8	Pulley, Driven	9453-168-003	1
*	Tolerance Ring driven pulley	9487-234-003	1
9	Screw 5/8-11x1/2" Driven pulley	9545-060-001	1
10	Lockwasher 5/8"	8641-582-018	1
11	Washer, Flat 5/8x2 1/4"	8641-581-032	1
12	Drive Belt	9040-076-005	2
13	Hose, Overflow Vent Top	9242-463-003	1
*	Clamp, Hose Vent	8654-117-008	1
14	Hose, Overflow to drain	9242-449-002	1
*	Clamp, Hose overflow to drain	8654-117-018	2

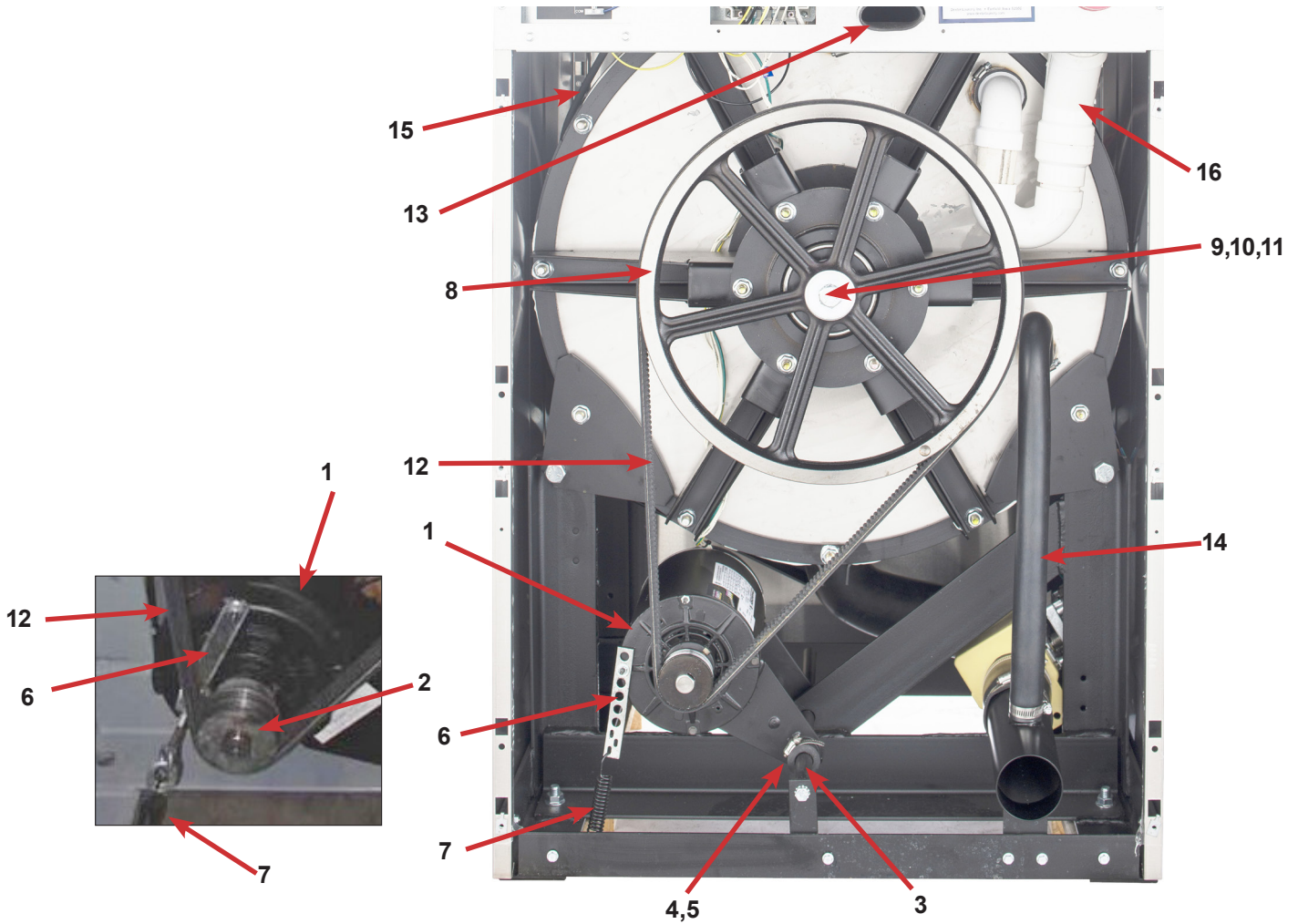

Key	Description	T-600	QTY
15	Hose, Pressure Switch	9242-175-002	1
*	Clamp, Pressure Switch Hose	8654-117-015	1
	Vacuum Breaker Mtg Bracket	9029-077-001	1
*	Vacuum Breaker ALL	9610-001-001	1
*	Clamp, Hose to Vacuum Breaker	8654-117-014	1
*	Hose, Vacuum Breaker to tub	9242-461-001	1
*	Hose, Vacuum Breaker to Injector	9242-461-001	1
*	Clamps	8654-117-014	1
16	Injector Assembly, Soap	9883-009-001	1
*	Hose, Injector to Tub Back	9242-462-001	1
*	Clamps	8654-117-014	1
*	Panel Assy., Back	9989-562-001	1
*	Screw Panel Mtg.#10x1/2"	9545-008-026	10
*	Nut, Spring	8640-399-004	10
*	Screw, To Base-1/4x3/4	9545-030-002	1

Rear View Access Part # by Model

Key	Description	T-900	T-1200	QTY
1	Drive Motor, 3 Ph.	9376-308-001	9376-329-001	1
2	Rod, Motor Mtg	9497-222-004	9497-222-004	1
3	New Motor bushing support	9053-082-001	9053-082-001	2
4	Clamp for motor bushing	8654-117-019	8654-117-019	2
5	Pulley, Motor	9453-175-002	9453-175-002	1
*	Split TaperBushing (motor pulley)	9053-077-001	9053-077-001	2
*	Screw taper bushing 1/4-20x1	9545-018-024	9545-018-024	3
6	Bolt, Eye (1/4"-20x1/2")	9545-055-001	9545-055-001	1
*	Nut, 1/4 Elastic Stop	8640-414-003	8640-414-003	1
*	Link (open end)	9341-046-001	9341-046-001	1
7	Chain (Spring Tension)	9099-012-003	9099-012-004	1
8	Spring, Belt Tension	9534-151-000	9534-151-000	1
9	Pulley, Driven	9453-176-006	9453-176-006	1
10	Bolt, 3/8"-16 x 2"	9545-029-011	9545-029-011	3
11	Washer, 3/8"	8641-582-003	8641-582-003	3
*	Bushing Taperlock (Driven)	9053-078-002	9053-078-002	1
12	Washer-Flat .675x2-1/2x1/4	8641-581-043	8641-581-043	1
13	Lockwasher-Exttooth, 5/8	8641-582-018	8641-582-018	1
14	Bolt, 5/8-11x1 1/2	9545-060-001	9545-060-001	1
15	Drive Belt	9040-079-002	9040-079-003	1
*	Panel Assy., Back	9989-526-001		1
*	Panel Back Upper		9454-905-001	1
*	Panel Back Lower		9454-904-001	1
*	Screw Panel Mtg.#10Bx1/2"		9545-008-026	9
*	Screw Panel Mtg.#10Bx1/2"	9545-008-026		9
*	Nut, Spring	8640-399-008	8640-399-008	AR
*	Screw, To Base-1/4" x 3/4"	9545-030-002	9545-030-002	3

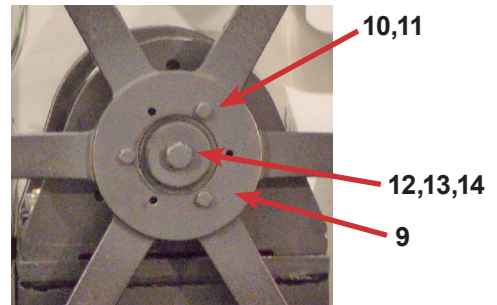
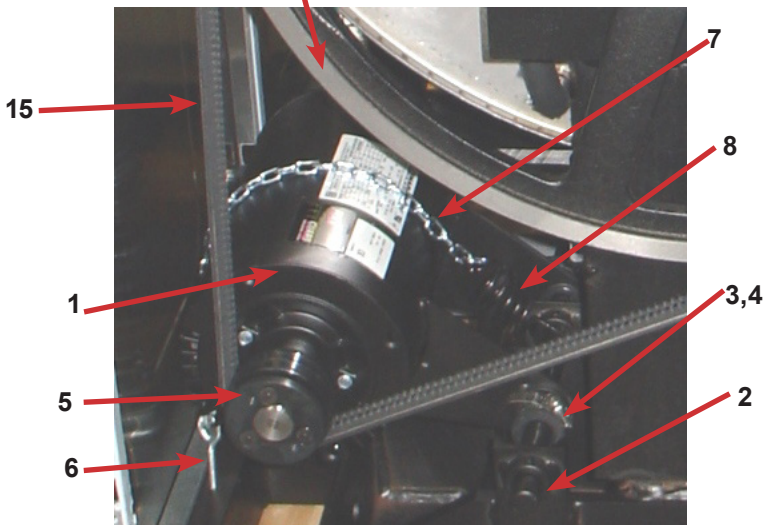
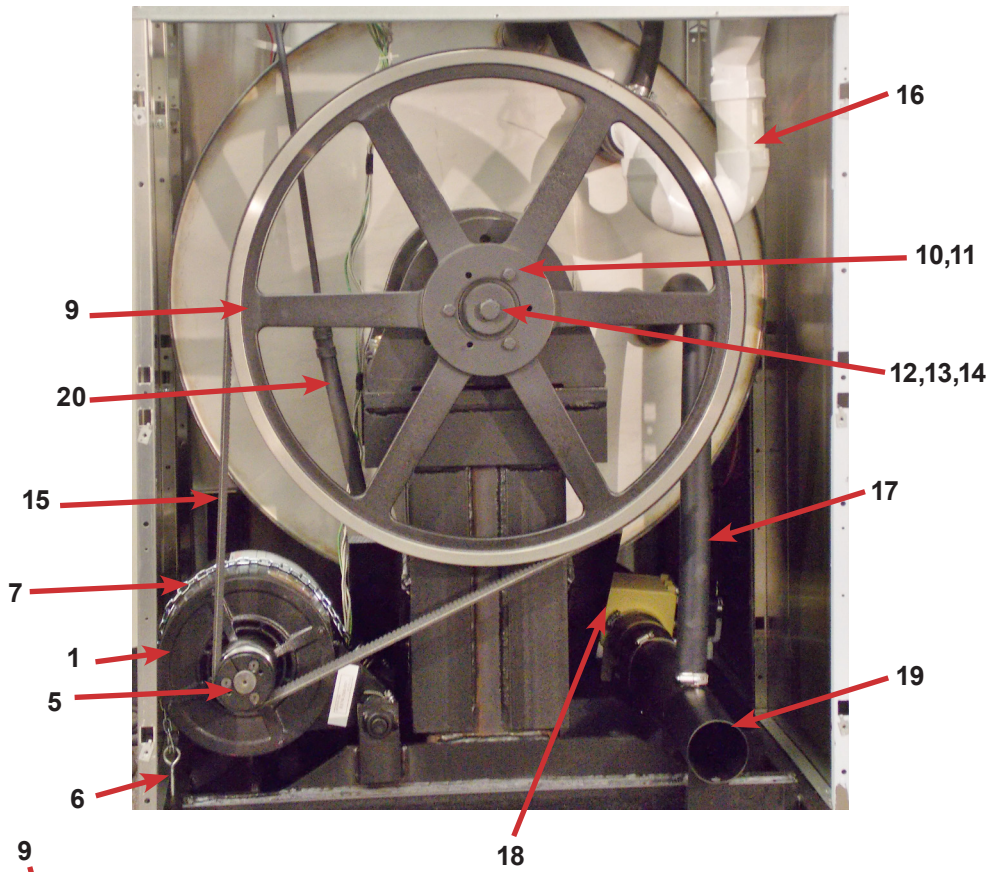

Key	Description	T-900	T-1200	QTY
16	Injection- tube assy	9883-012-001	9883-012-001	1
*	Inlet Cap	0935-135-001		*
*	Hose, Injection Tube to Tub	9242-461-001	9242-461-001	1
*	Clamp, Injection Hose	8654-117-014	8654-117-014	2
17	Hose-Overflow	9242-449-003	9242-449-003	1
*	Clamp Hose Over Flow	8654-117-008	8654-117-008	2
18	Drain Valve	9379-202-001	9379-202-001	1
*	Hose, Drain Valve to Tube	9242-457-001	9242-457-001	1
*	Clamp	8654-117-014	8654-117-014	2
19	Drain Tube	9915-120-004	9915-126-002	1
20	Hose-Pressure Switch	9242-175-007	9242-175-004	1

Rear View Upper Access Part # by Model Continued

Key	Description	T600	T900	T1200	QTY
1	Channel Assembly Rear	9947-026-001	9947-028-001	9947-028-001	1
2	Screw #10Bx1/2	9545-008-026	9545-008-026	9545-008-026	4
*	Nut, Spring	8640-399-007	8640-399-007	8640-399-007	4
3	Plug, 7/8"	9456-041-006	9456-041-006	9456-041-006	1
4	Bushing, 7/8"	9053-067-002	9053-067-002	9053-067-002	1
5	Bracket-Terminal Block Assy	9029-265-001	9029-265-001	9029-265-001	1
6	Screw, 10Bx1/2	9545-008-026	9545-008-026	9545-008-026	4
7	Strip-Terminal marker, Power	9558-025-001	9558-025-001	9558-025-001	1
8	Terminal Block-Power	9897-033-002	9897-033-002	9897-033-002	1
*	Screw-6ABx3/4	9545-031-010	9545-031-010	9545-031-010	2
9	Harness-Power Terminal Block	9627-747-003	9627-747-003	9627-747-003	1
10	Terminal Lug, Solderless	8652-134-001	8652-134-001	8652-134-001	1
*	Lockwasher #10	8641-582-006	8641-582-006	8641-582-006	1
*	Screw-10-32ttX1x1/2 GRN	9545-008-027	9545-008-027	9545-008-027	2
11	Strip-Terminal Marking, Injector	9558-028-001	9558-028-001	9558-028-001	1
12	Terminal Block-Injector	9897-032-002	9897-032-002	9897-032-002	1
*	Screw-4Bx5/8ss	9545-053-002	9545-053-002	9545-053-002	2
13	Harness-Injection	9627-799-001	9627-799-001	9627-799-002	1
14	Label-Warning	8502-639-001	8502-639-001	8502-639-001	1
15	Bushing-Insulated, 3/4"	9053-067-001	9053-067-001	9053-067-001	1
16	Bushing-Insulated, 1"	9053-067-004	9053-067-004	9053-067-004	1
*	Cover, Terminal Block	9074-267-001	9074-267-001	9074-267-001	1
*	Screw #10Bx1/2	9545-008-026	9545-008-026	9545-008-026	1
17	Plate-Drive mounting	9982-383-001	9982-383-001	9982-383-001	1
18	Nut, #10-32UNF, 2B	8460-413-002	8460-413-002	8460-413-002	4
19	VFD Delta "E" drive 208-240 volt	9375-030-012	9375-028-016	9375-028-013	1
*	Key Pad-Display Delta "E" Drive (P/S) only	9150-044-001	9150-044-001	9150-044-001	
20	Nut, #10-32UNF, 2B	8460-413-002	8460-413-002	8460-413-002	4
*	Cable, Data	9806-015-001	9806-015-001	9806-015-003	1
*	Clamp, Cable	8654-125-005	8654-125-005	8654-125-005	1
21	Plate-Water Valves, Mounting	9452-813-001	9452-814-001	9452-814-001	1
22	Nut, #10-32UNF, 2B	8460-413-002	8460-413-002	8460-413-002	4
23	Valve-Water, Duel Coil	9379-183-012	9379-183-012	9379-183-012	2
24	Screw #10Bx1/2	9545-008-026	9545-008-026	9545-008-026	4
25	Water-Valve, Single Coil		9379-194-001	9379-194-001	2
26	Screw-Phillips, 4mx0.7x8mm		9545-064-001	9545-064-001	4
27	Shield, Water Valves	9550-194-001	9550-195-001	9550-195-001	1
28	Clip-Push	9083-121-001			3
28	Clip-Push		9083-121-001	9083-121-001	4
29	Cap-Injector Assy	0935-127-001	0935-127-001	0935-127-001	1
30	Clamp	8654-117-014	8654-117-014	8654-117-014	1
31	Hose-Suds Overflow	9242-463-003	9242-463-004	9242-463-004	1
32	Resistors (160 Ohm)	9483-004-002	9483-004-003	9483-004-003	2
33	Screws #10-32x1/2" (Mounting)	9545-012-008	9545-012-008	9545-012-008	4
34	Jumper Wires	8220-117-002	8220-117-002	8220-117-002	2

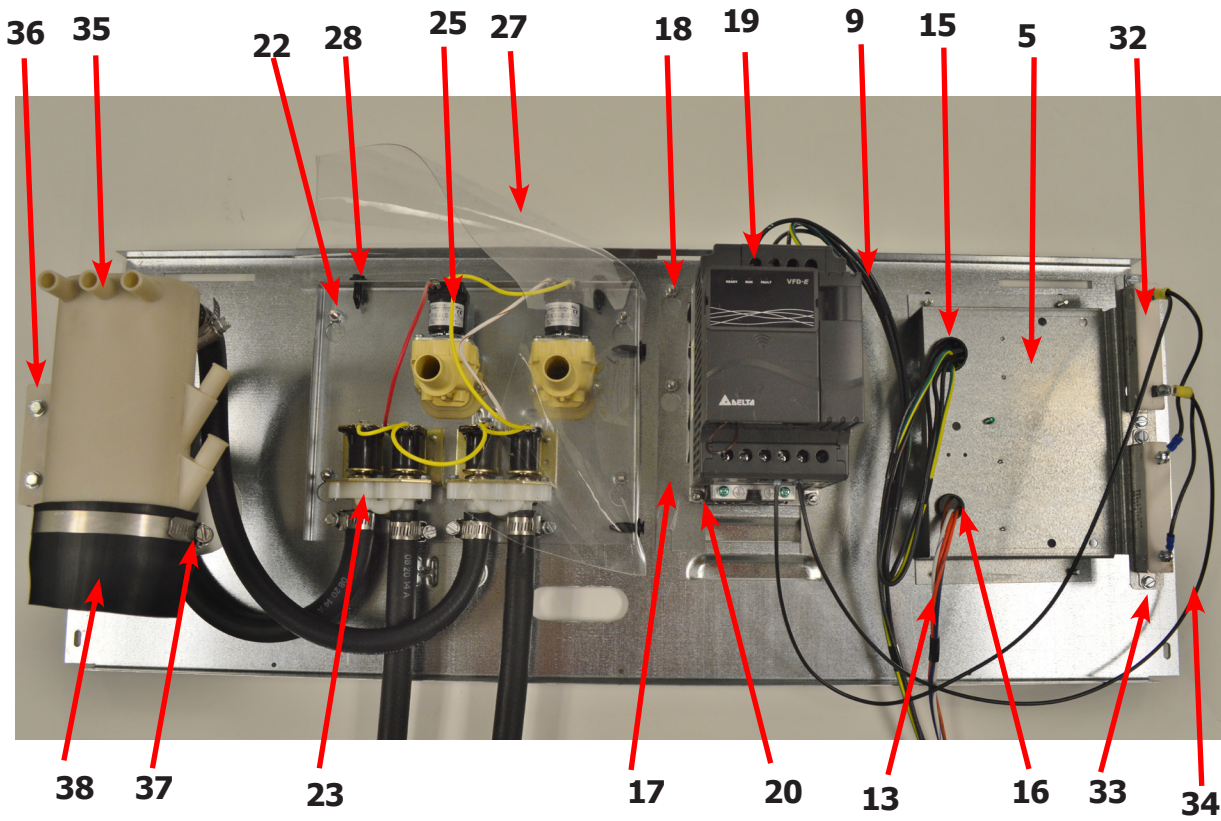
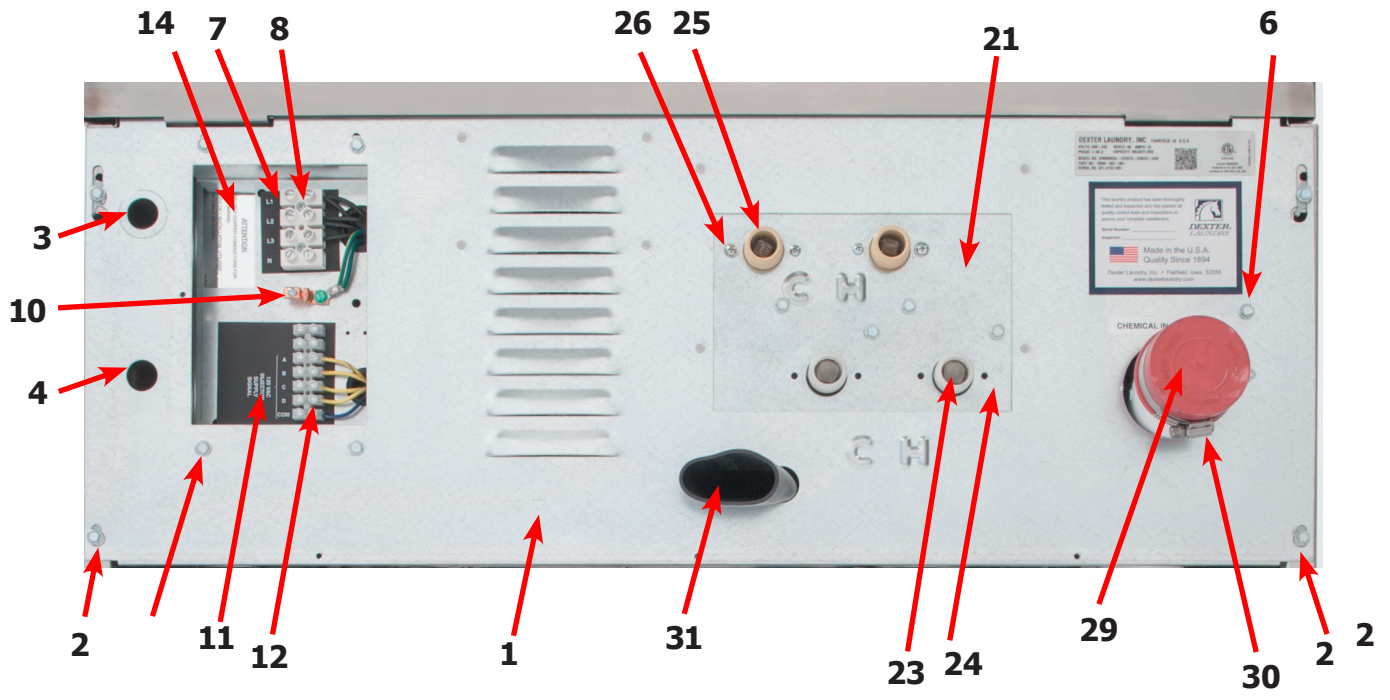

Key	Description	T-600	T-900	T-1200	QTY
35	Vacuum Breaker	9610-001-001	9610-001-001	9610-001-002	1
*	Bracket-Vacume Breaker	9029-077-001	9029-077-001	9029-077-001	1
36	Screw, 10Bx1/2	9545-008-026	9545-008-026	9545-008-026	4
37	Clamp, Vacuum Breaker End	8654-117-014	8654-117-014	8654-117-014	1
38	Hose, Vacuum Breaker to Tub Injection Tube	9242-461-001	9242-461-001	9242-461-001	1

Cylinder, Seals & Bearings Part # T-600

Key	Description	T-600	QTY
*	Bearings and Seal Kit	9732-219-005	1
*	Housing, Bearing- Assembly (items #2-#6)	9803-186-001	1
2	Housing, Bearing	9241-180-002	1
3	Bearing, Front (LARGE)	9036-159-005	1
4	Bearing, Rear (SMALL)	9036-159-004	1
5	Spacer, Bearing	9538-167-001	1
6	Ring, Bearing Retainer	9487-238-003	1
7	Tub Back Mating Ring	9487-261-003	1
8	Seal, Large	9532-140-009	1
9	Seal, Small	9532-140-006	1
10	Ring, Seal Mounting	9950-048-001	1
11	Back Assy, Tub	9962-013-001	1
12	Bolt 7/16-14x1 1/2" Tub end of bearing housing	9545-059-003	6
12	Nut 5/8"	8640-425-001	6
13	Support Arm Assy, Bearing Housing	9991-056-002	6
14	Bolt Pulley end of bearing housing (7/16-14x2")	9545-059-002	6
14	Nut, Flange Locking 7/16"	8640-416-005	6
15	Pulley, Driven	9453-168-003	1
*	Ring, Tolerance	9487-234-003	1
16	Washer 5/8"	8641-581-032	1
18	Bolt 5/8-11x1 1/2"	9545-060-001	1
18	Lockwasher 5/8 Ext. tooth	8641-582-018	1
*	Cylinder Assy	9848-113-001	1
*	Tub and Cylinder Assy.	9869-033-001	1
*	Tub Assembly	9930-164-001	1

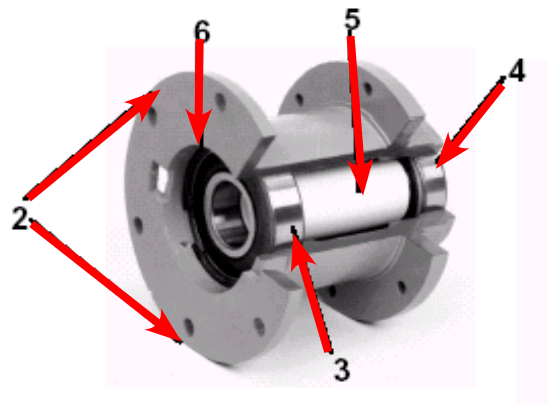
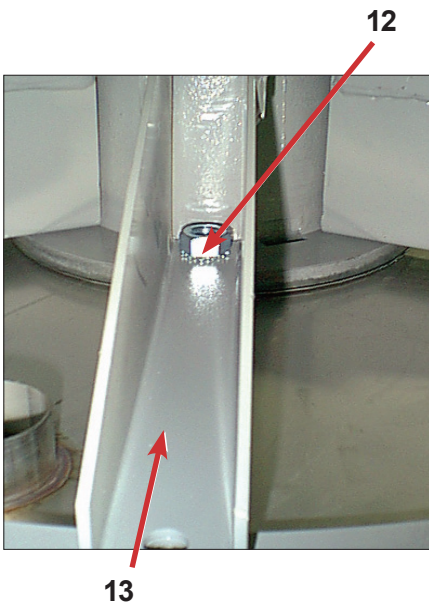
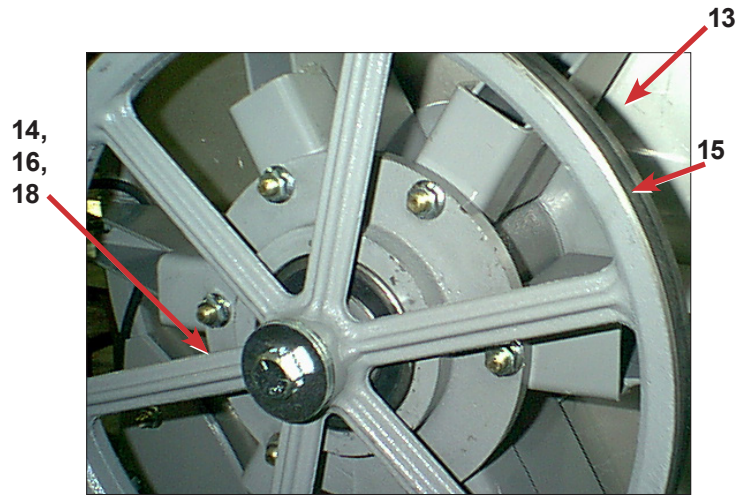
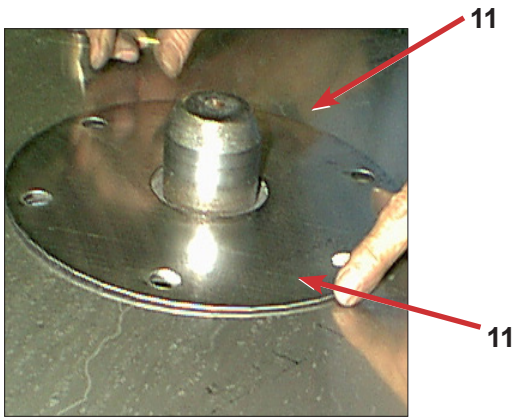
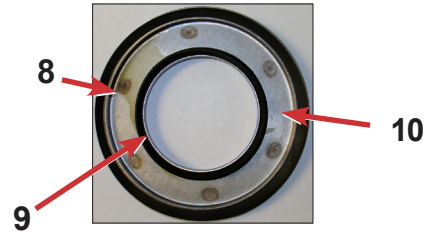
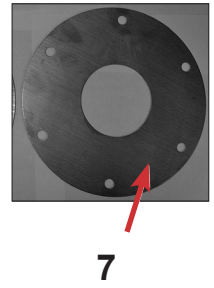
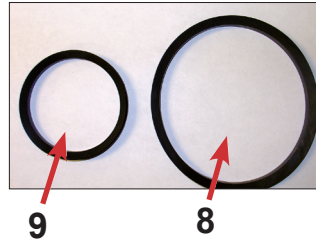
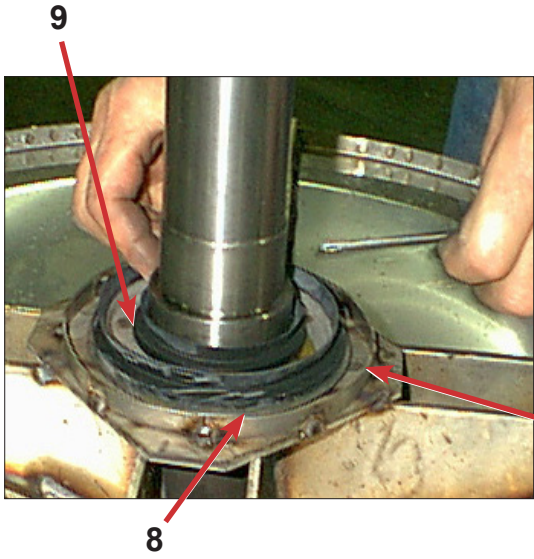

Cylinder, Seals & Bearings Part # by Model

Key	Description	T-900	T-1200	QTY
*	Bearings and Seal Kit	9732-219-007	9732-219-007	1
1	Housing, Bearing- Assembly (items #2-#6)	9803-187-001	9803-187-001	1
2	Housing, Bearing	9241-181-004	9241-181-004	1
3	Bearing, Front (LARGE)	9036-159-006	9036-159-006	1
4	Bearing, Rear (SMALL)	9036-159-005	9036-159-005	1
5	Spacer, Bearing	9538-170-001	9538-170-001	1
6	Ring, Bearing Retainer	9487-238-004	9487-238-004	1
7	Tub Assembly	9930-157-001	9930-150-001	1
8	Seal, Primary V85A	9532-140-007	9532-140-007	1
9	Seal, Secondary V140A	9532-140-008	9532-140-008	1
10	Ring, Seal Mounting	9950-052-001	9950-052-001	1
11	Tub Back Mating Ring	9950-054-004	9950-054-004	1
11G	Mating Ring Guard Shield	9487-266-001	9487-266-001	1
12	Bolt, Tub End of Bearing Housing (7/16-14x1), Bolt from inside Tub	9545-059-004	9545-059-004	6
13	Washer, Flat	8641-581-034	8641-581-034	6
14	Screw-Hex Cap, 3/4"-10 x 3" (Bearing Housing to Frame)	9545-057-002	9545-057-002	6
15	Washers Spherical 3/4 (Male half) (Bearing Housing to Frame)	8641-588-001	8641-588-001	6
16	Washers Spherical 3/4 (Female half) (Bearing Housing to Frame)	8641-588-002	8641-588-002	6
15	Washer, Flat	8641-581-033		6
16	Lock Washer-Extrenal Tooth, 3/4" (Bearing Housing to Frame)	8641-582-020		6
17	Nut 3/4"-10 (Bearing Housing to Frame)	8640-418-003	8640-418-003	6
18	Pulley, Driven	9453-176-006	9453-176-006	1
19	Bolt, 3/8"-16 x 2"	9545-029-011	9545-029-011	3
20	Washer, 3/8"	8641-582-003	8641-582-003	3
21	Bushing Taperlock (Driven & Large)	9053-078-002	9053-078-002	1
22	Washer-Flat .675x2-1/2x1/4	8641-581-043	8641-581-043	1
23	Lockwasher-Exttooth, 5/8	8641-582-018	8641-582-018	1
24	Bolt, 5/8-11x1 1/2	9545-060-001	9545-060-001	1
25	Tub & Cylinder Assy Before Serial #535659	9869-023-003	9869-022-001	1
25	Tub & Cylinder Assy After Serial #535659	9869-027-004	9869-022-003	1

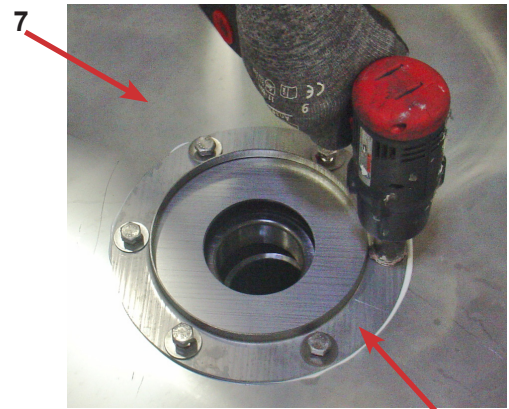
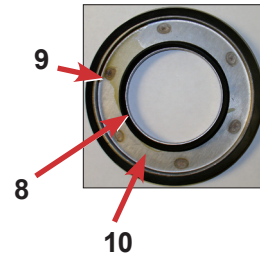
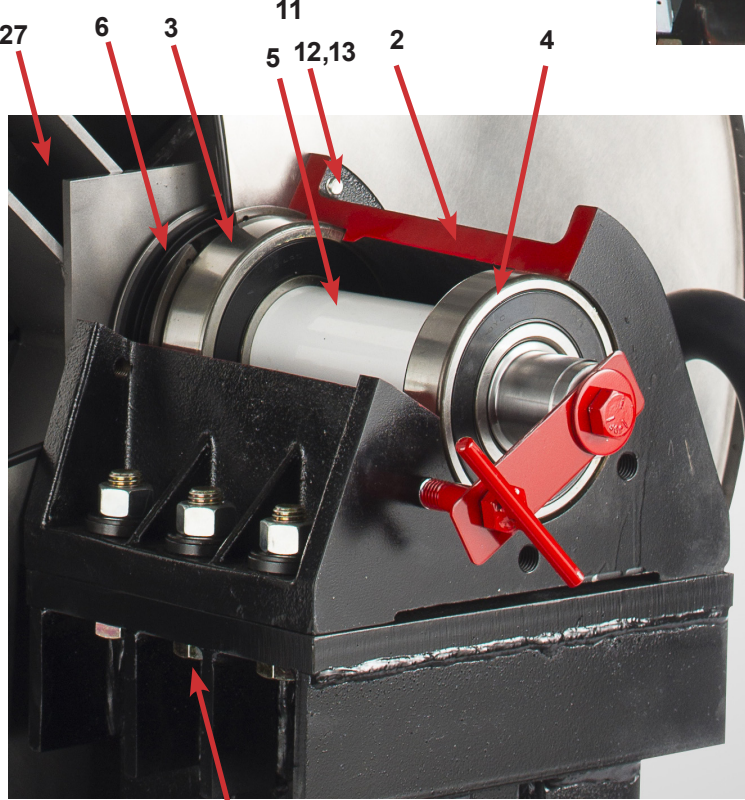
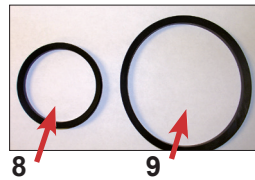
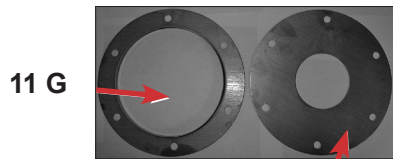
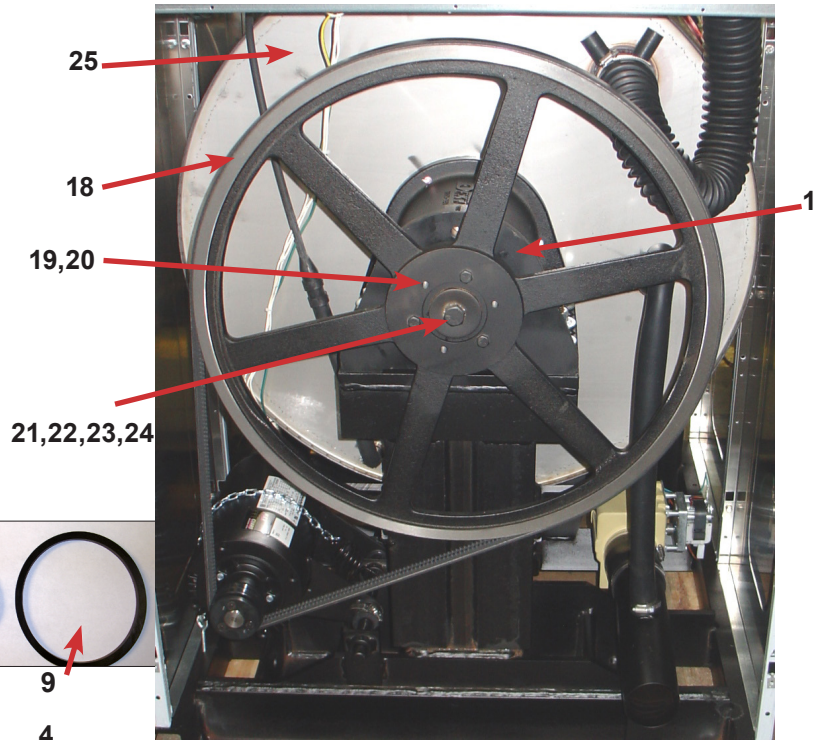
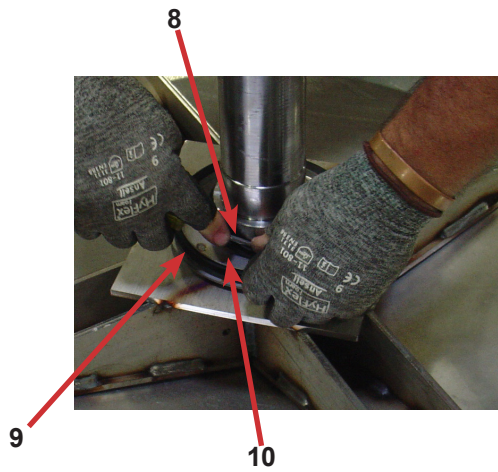

14,15,16,17

11

Key	Description	T-900	T-1200	QTY
27	Cylinder Assy	9848-136-001	9848-137-001	
*	Tub Front	9974-011-001	9974-011-002	1
*	Gasket, Tub Front	9206-421-002	9206-421-002	1
*	Ring Assy, Tub Mtg-Front Clamp	9950-055-001	9950-055-001	1
*	Bolt, Top Front Ring 3/8"-16 x 3"	9545-029-009	9545-029-009	1
*	Nut 3/8"-16	8640-415-001	8640-415-001	1

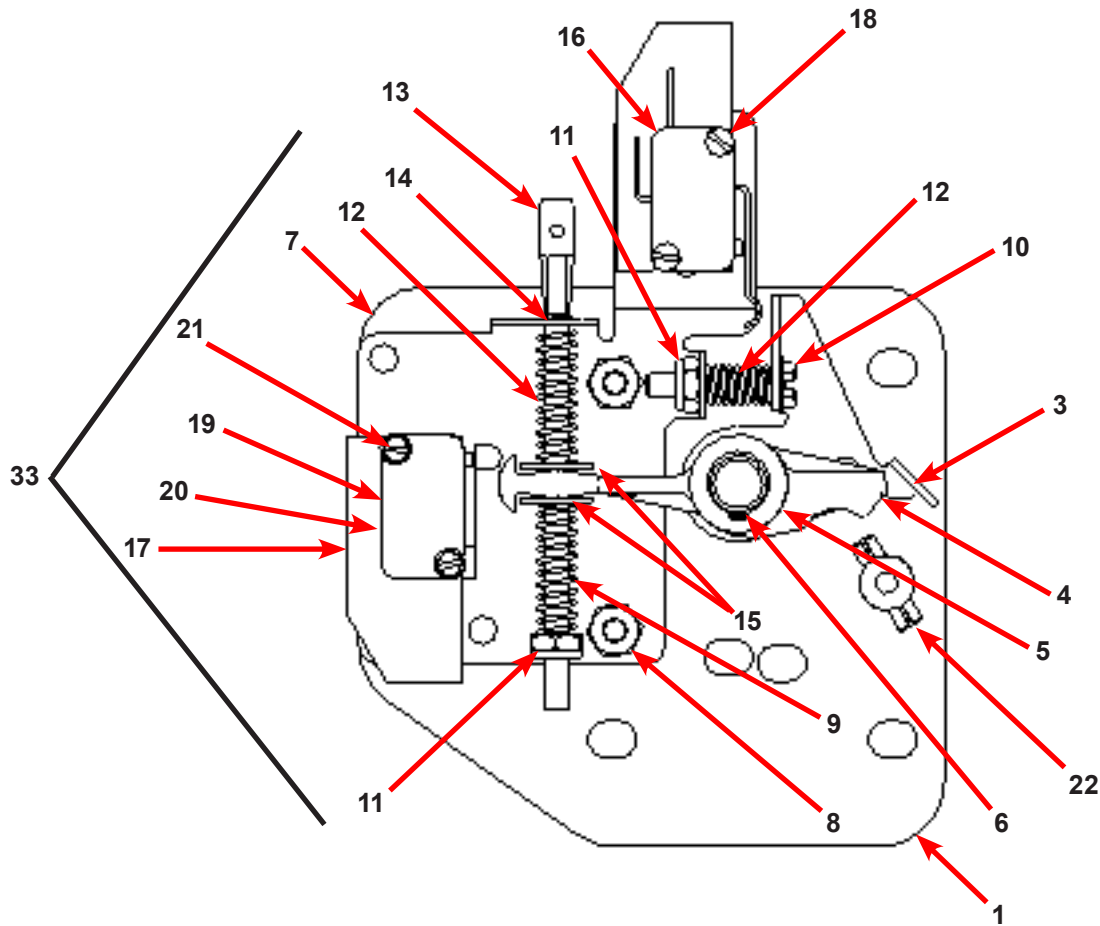

Door Lock Assembly

Key	Description	All Models	QTY
33	Lock Assy, Complete (#1-22) (includes #1 thru #22)	9885-024-001	1
1	Plate Assy, Door Lock	9982-346-001	1
2	Washer, Flat (SS or Brass)	8641-581-030	1
3	Actuator, Latching Switch	9008-005-001	1
4	Pawl, Locking	9732-346-002	1
5	Washer, Spring	8641-569-003	1
6	Ring, Retaining	9487-200-004	1
7	Bracket Switch	9029-163-001	1
8	Nut, Hex 10-32 UNF	8640-413-002	2
9	Spring, Actuating	9534-364-002	1
10	Screw, Hx. 10-32 x 1"	9545-012-020	1
11	Nut, Elastic Stop 10-32	8640-413-004	2
12	Spring, Return	9534-364-001	2
13	Pin, Guide	9451-193-001	1

Key	Description	All Models	QTY
14	Ring, Retaining	9487-200-005	1
15	Washer	8641-581-031	1
16	Switch, Latching Sensing	9539-461-008	1
17	Shield, Switch	9550-169-003	3
18	Screw 4-40 x 5/8"	9545-020-001	2
18	Nut, Twin 4-40	8640-401-001	1
19	Switch, Locking Sensing	9539-461-007	2
20	Actuator, Switch Locking	9008-006-003	1
21	Screw 4-40 x 1 1/8"	9545-020-003	2
21	Nut, Twin 4-40	8640-401-001	1
*	Spacer Sensor	9538-182-001	*
22	Pin, Dowel (for door cam)	9451-181-004	1
*	Shim, Door Lock, Thin	9552-037-001	AR
*	Screw, Lock mtg 1/4"-20 x 3/4"	9545-018-014	3
*	Lockwasher 1/4" Ext tooth	8641-582-007	3
*	Door Stud Pin, 3/16" x 3/4"	9451-181-004	1

Gear Motor Door Lock Assembly

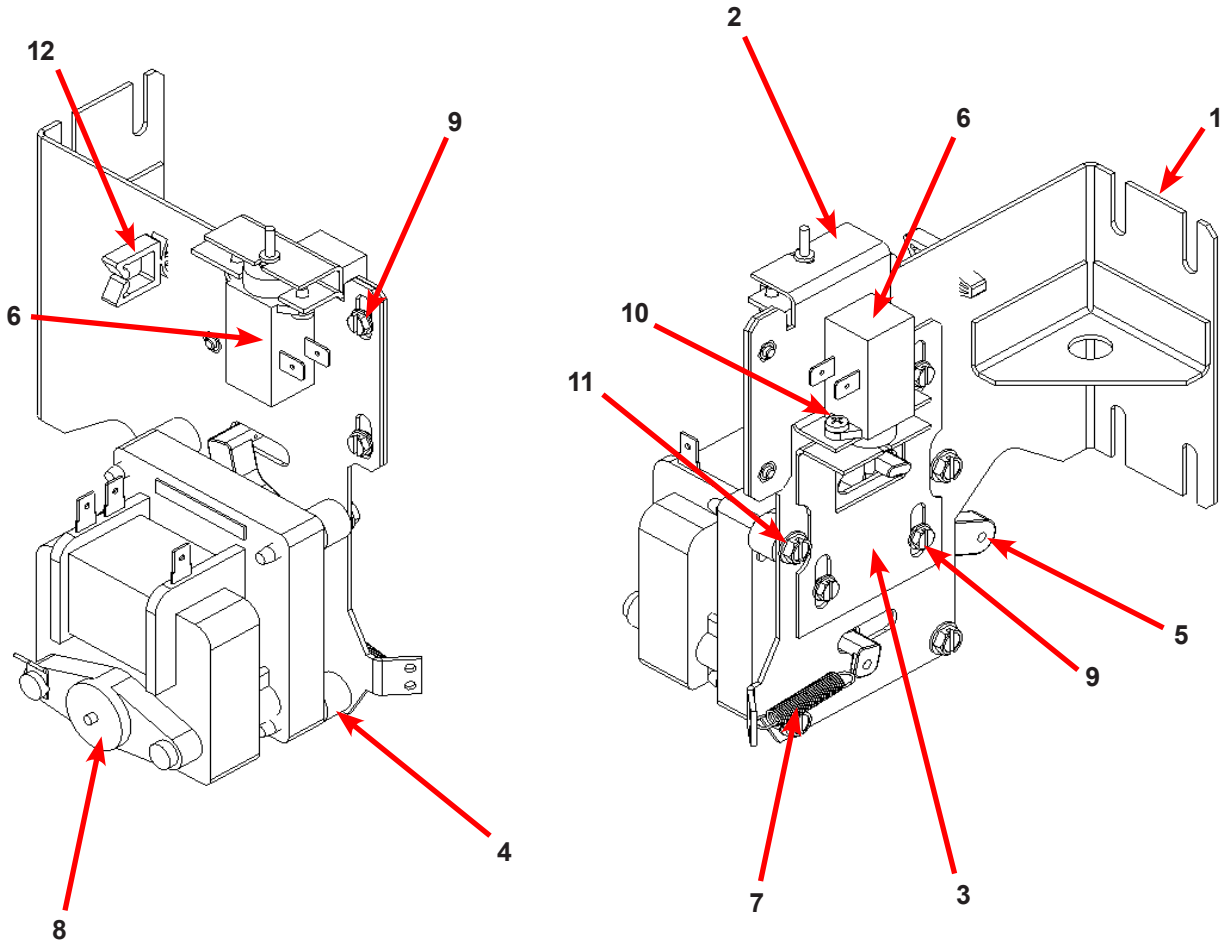

Key	Description	T-600	T-900	T-1200	QTY
*	Actuator Assembly (Includes 1-10, Rod NOT included)	9892-015-001	9892-015-001	9892-015-001	1
11	Screw - hxwshdsl, 10-24 - 1.25f, ctd	9545-046-007	9545-046-007	9545-046-007	4
10	Cross Recessed PAn Hd Tapping screw	9545-031-011	9545-031-011	9545-031-011	4
9	Screw -Hxwshrdslsems, 6-32 x 3/16	9545-044-003	9545-044-003	9545-044-003	6
8	Motor & Gear Assembly 120v	9914-137-015	9914-137-015	9914-137-015	1
7	Spring - Extension	9534-350-001	9534-350-001	9534-350-001	1
6	Thermoactuator - Door Lock Relay 120v	9586-001-001	9586-001-001	9586-001-001	2
5	Arm - Door Lock	9001-063-001	9001-063-001	9001-063-001	1
4	Spacer, Plastic	9538-157-021	9538-157-021	9538-157-021	4
3	Bracket Slide Lock	9029-204-001	9029-204-001	9029-204-001	1
2	Bracket Assy, Slide - Unlock	9985-189-001	9985-189-001	9985-189-001	1
1	Bracket Assy, Slide Lock Actuator	9985-190-001	9985-190-001	9985-190-001	1
*	Rod, Door Lock	9497-225-010	9497-225-013	9497-225-015	1

Large Door & Hinge Group

Key	Description	T-900	T-1200	
1	Door Hinge Assembly (mounts to tub front)	9955-031-001	9955-031-001	1
*	Door Assembly Complete	9960-310-001	9960-310-001	1
2	Door Ring 180 degree large hnge	9487-275-001	9487-275-001	1
3	Door Gasket	9206-431-001	9206-431-001	1
4	Door Glass Window	9635-020-001	9635-020-001	1
*	Red Wire (Door Close Switch)	8220-063-028	8220-063-028	2
5	Switch, Door Hinge Close (Plunger)	9539-492-001	9539-492-001	1
6	Top Door Hinge Leaf (No pin)	9845-006-001	9845-006-001	1
7	Bottom Door Hinge Leaf	9845-007-001	9845-007-001	1
8	Thrd Form Screw, Door Mtg 5/16" x 5/8"	9545-056-002	9545-056-002	4
9	Screw, Loading Door Hinge Mtg (5/16" x9/16" ss)	9545-014-013	9545-014-013	3
10	Bracket Retainer support side panel	9029-191-001	9029-191-001	1
*	Shim Large door	9552-043-001	9552-043-001	1

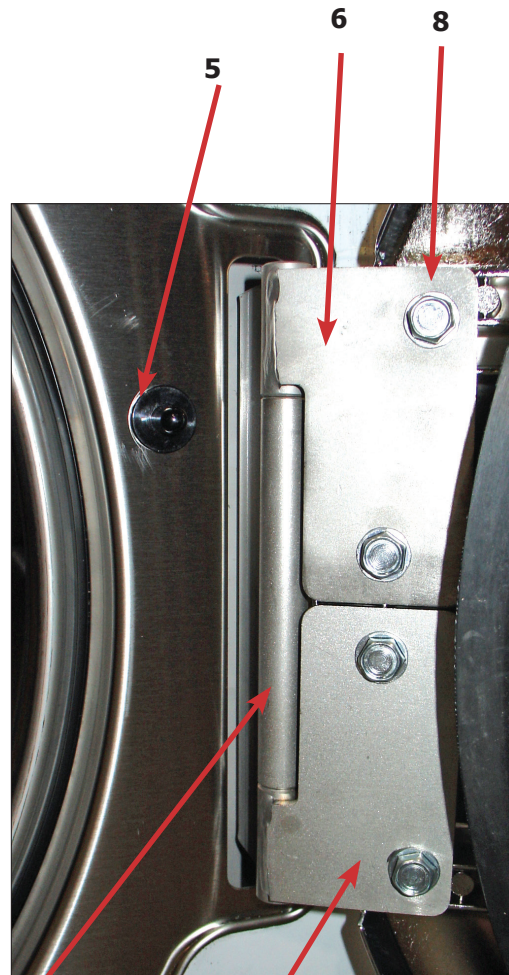
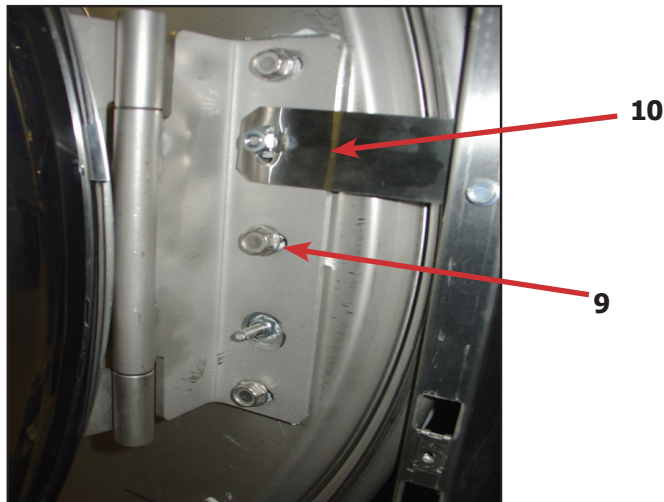

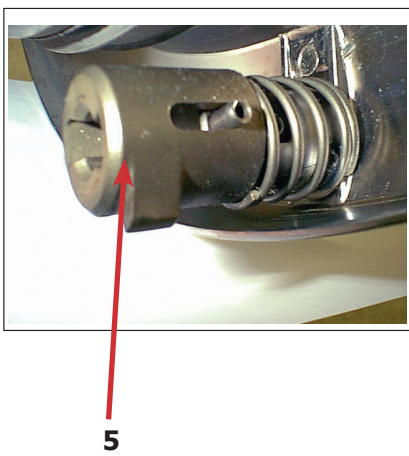
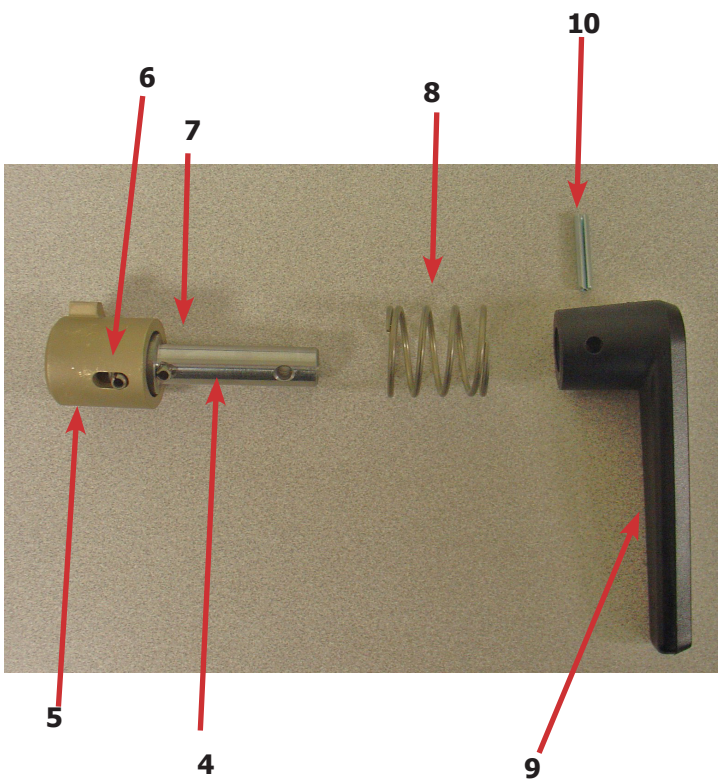
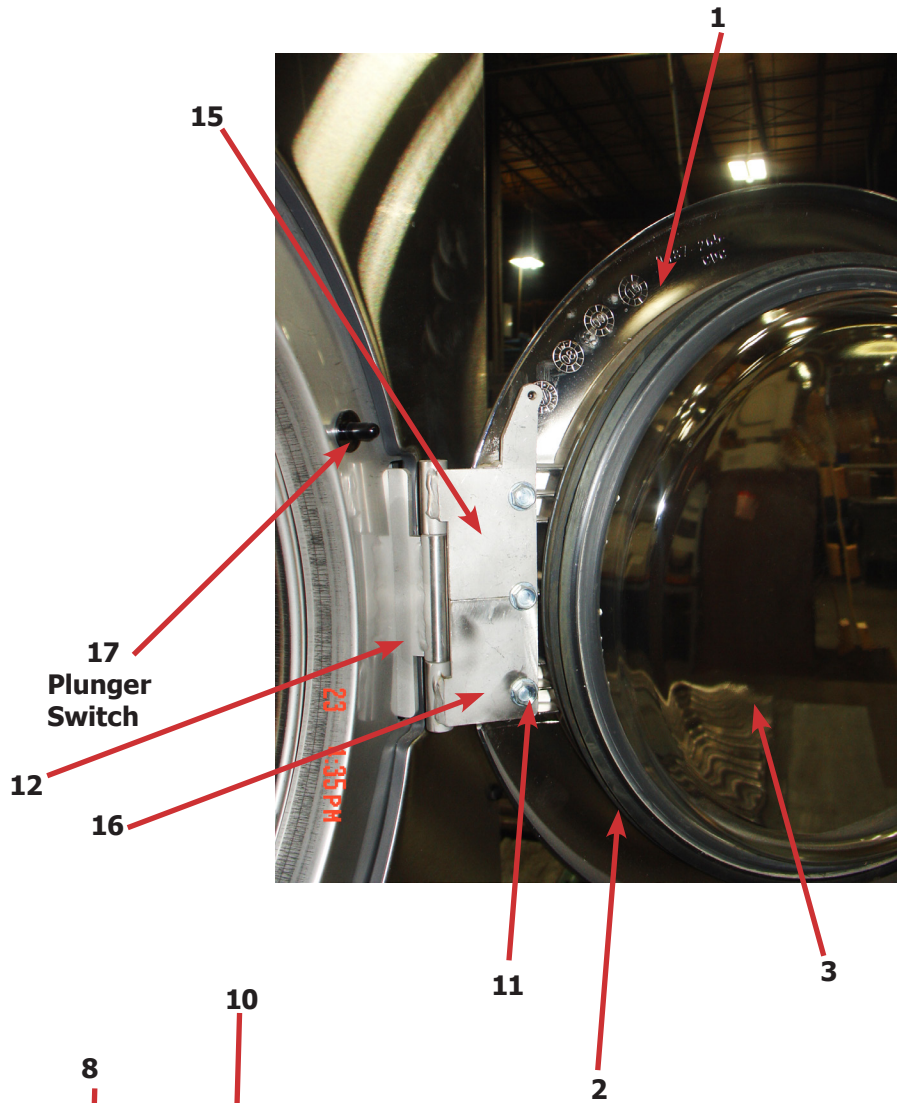

Standard Loading Door & Hinge Group

	Door Size	Standard	Standard	Standard	
Key	Description	T-600	T-900	T-1200	QTY
*	Loading Door, Complete #1-10	9960-309-001	9960-310-001	9960-310-001	1
1	Loading Door, Ring	9487-265-002	9487-265-002	9487-265-002	1
2	Gasket, Loading Door	9206-419-001	9206-429-001	9206-429-001	1
3	Window, Loading Door	9635-016-001	9635-016-001	9635-016-001	1
*	Shaft Assy, Locking (includes 4 thru 7)	9913-134-003	9913-134-003	9913-134-003	1
4	Shaft, Door Locking	9537-195-002	9537-195-002	9537-195-002	1
5	Cam, Locking	9095-040-002	9095-040-002	9095-040-002	1
6	Roll Pin Type, Groove (1 1/4)	9451-181-005	9451-181-005	9451-181-005	1
7	Roll Pin Type, Groove (3/4)	9451-181-004	9451-181-004	9451-181-005	1
8	Spring, Lock Cam	9534-360-002	9534-360-002	9534-360-002	1
9	Handle, Door	9244-091-001	9244-091-001	9244-091-001	1
10	Roll Pin Type, Door Handle (groove)	9451-181-006	9451-181-006	9451-181-006	1
11	Thrd Form Screw, Door Mtg 5/16" x 5/8"	9545-056-002	9545-056-002	9545-056-002	3
*	Lockwasher 5/16" Ext hinge mtg	8641-582-009	8641-582-009	8641-582-009	3
*	Shim, Loading Door Hinge, Thin	9552-036-001	9552-043-001	9552-043-001	AR
12	Door Hinge Assembly Mounts to Tub Front	9955-030-001	9955-031-001	9955-031-001	1
*	Screw, Loading Door Hinge Mtg (5/16" -18x3/4" ss)	9545-014-009	9545-014-009	9545-014-009	3
*	Screw, Loading Door Hinge Mtg (5/16" x9/16" ss)		9545-014-013	9545-014-013	3
*	Wiring Harness doorlock safety switch assembly to I/O PCB Board	9627-893-001	9627-837-001	9627-891-001	1
*	Wire, BLK Door Close Switch	8220-063-026	8220-063-026		1
*	Wires, Red Door Close Switch	8220-063-025	8220-063-025		1
*	Wires, Red Door Closed Switch		8220-063-028	8220-063-028	2
15	Leaf, Door Hinge (Top)	9845-008-001	9845-005-004	9845-005-004	1
16	Leaf,, Door Hinge (Bottom)	9845-005-002	9845-005-002	9845-005-002	1
17	Switch,Door Hinge Close(Plunger)	9539-492-001	9539-492-001	9539-492-001	1

Drain Valve Group Part # by Model

Key	Description	T-600	T-900	T-1200	QTY
1	Valve, Drain (includes #2 thru #11)	9379-202-001	9379-202-001	9379-202-001	1
2	Body, Valve (w/ball)	9064-070-001	9064-070-001	9064-070-001	1
3	Motor & Gear Train (complete)	9914-137-017	9914-137-017	9914-137-017	1
4	Plate, Motor Mtg	9452-538-001	9452-538-001	9452-538-001	1
5	Screw	8639-994-001	8639-994-001	8639-994-001	3
6	Spring, Drive	9534-339-001	9534-339-001	9534-339-001	1
7	Screw	9545-054-001	9545-054-001	9545-054-001	2
8	Screw	9545-054-002	9545-054-002	9545-054-002	1
9	Seal, V Packer	9532-134-001	9532-134-001	9532-134-001	2
10	Washer	8641-584-001	8641-584-001	8641-584-001	1
11	Pin, Main Drive	9451-196-001	9451-196-001	9451-196-001	1
*	Plate (spacers needed for replacement motor mtg. plate)	9538-149-001	9538-149-001	9538-149-001	4
13	Stator and Coil Assembly	9089-036-004	9089-036-004	9089-036-004	1
*	Seal Kit	9732-327-001	9732-327-001	9732-327-001	1

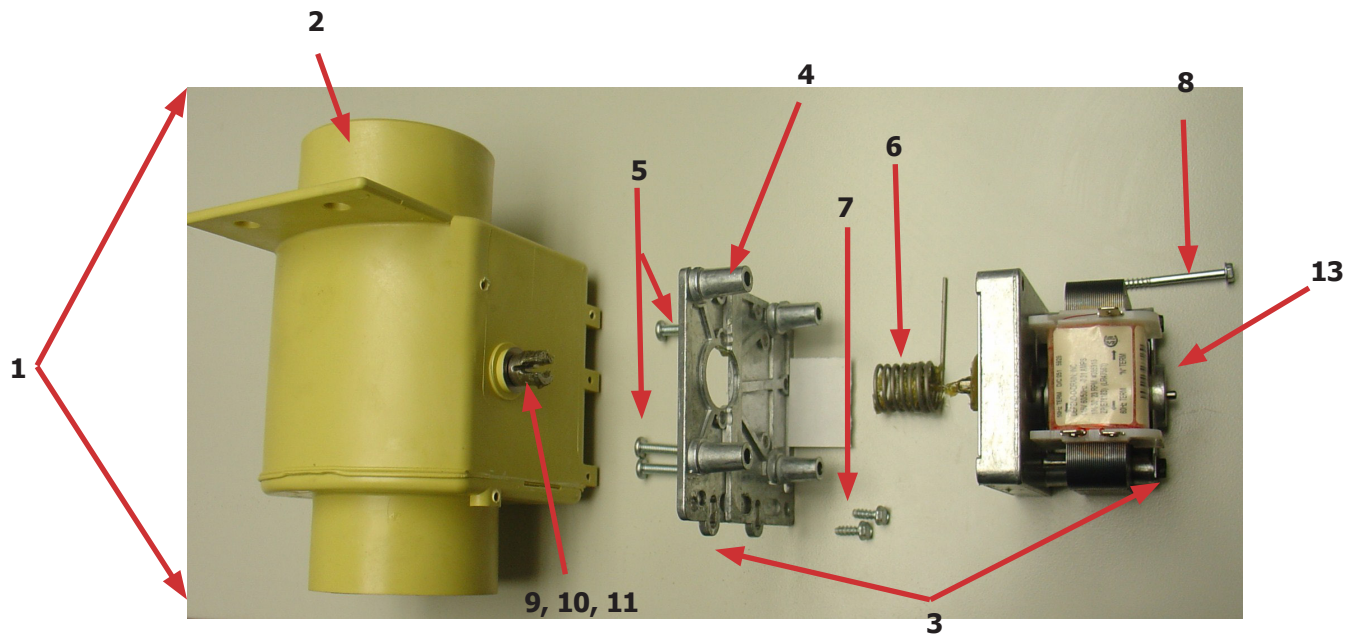

Water Inlet Valve Breakdown Part # by Model

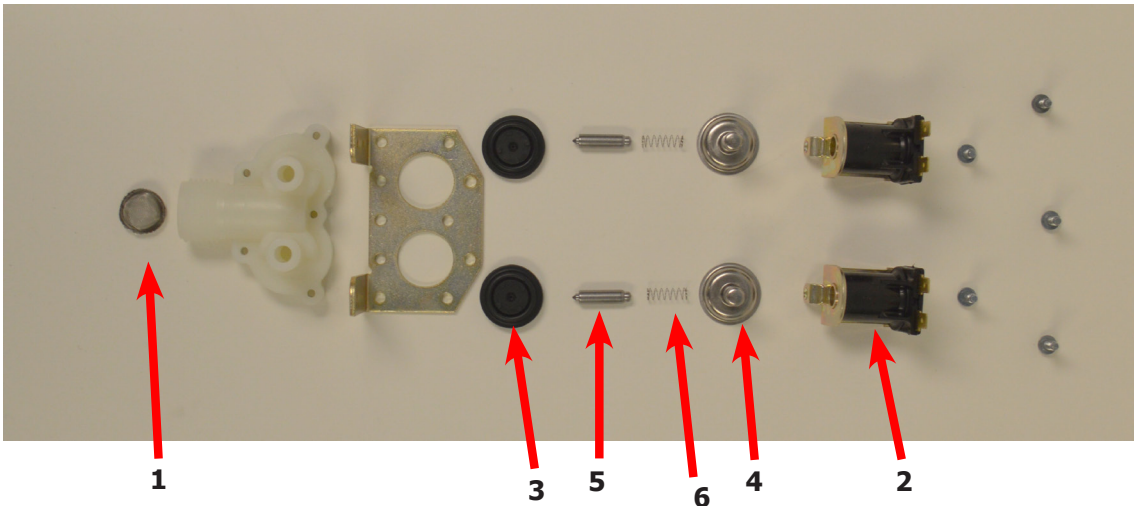

Key	Description	T-600	T-900	T-1200	QTY
*	Valve, Water Inlet (includes 1 thru 6)	9379-183-012	9379-183-012	9379-183-012	2
1	Screen, Inlet end of valve	9555-056-001	9555-056-001	9555-056-001	2
2	Coil Assy., 120 V Invensys	9089-017-001	9089-017-001	9089-017-001	2
*	Diaphragm Invensys (EPDM)	9118-049-001	9118-049-001	9118-049-001	2
*	Diaphragm Invensys (Viton)	9118-049-002	9118-049-002	9118-049-002	2
3	Diaphragm Invensys (EPDM NSF)	9118-049-003	9118-049-003	9118-049-003	2
4	Guide, Solenoid Invensys	9211-021-002	9211-021-002	9211-021-002	2
5	Armature Invensys	9015-008-001	9015-008-001	9015-008-001	2
6	Spring, Armature Invensys	9534-298-001	9534-298-001	9534-298-001	2

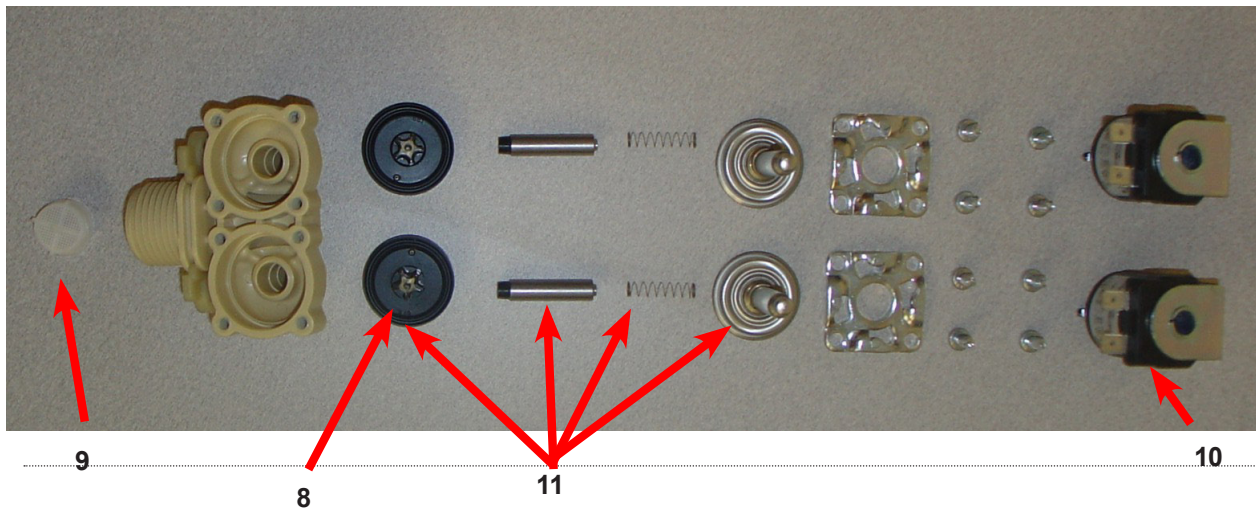

Optional Water Valve

Key	Description	T-600	T-900	T-1200	QTY
*	Dual Coil Water Valve Mueller	9379-192-001	9379-192-001	9379-192-001	1
7	Valve Water Body Complete(no coil)	9379-192-002	9379-192-002	9379-192-002	1
8	Diaphragm Mueller	9118-054-001	9118-054-001	9118-054-001	2
9	Filter Mueller	9183-046-001	9183-046-001	9183-046-001	2
10	Coil Mueller	9089-051-001	9089-051-001	9089-051-001	2
11	Diaphragm Assembly Mueller Includes	9785-001-001	9785-001-001	9785-001-001	2

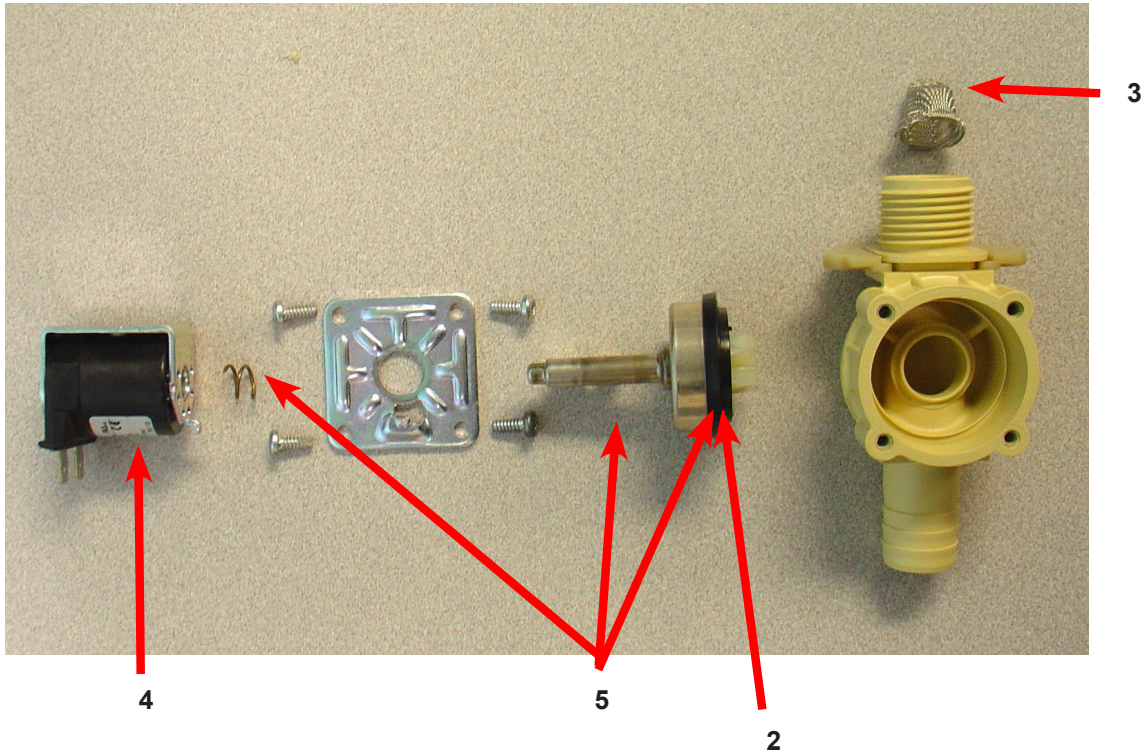

Key	Description	T-600	T-900	T-1200	QTY
*	Single Coil Water Valve Mueller		9379-194-001	9379-194-001	2
1	Valve Water Body Complete (no coil)		9379-194-002	9379-194-002	2
2	Diaphragm Mueller		9118-055-001	9118-055-001	1
3	Filter Mueller		9183-046-001	9183-046-001	1
4	Coil Mueller		9089-051-001	9089-051-001	1

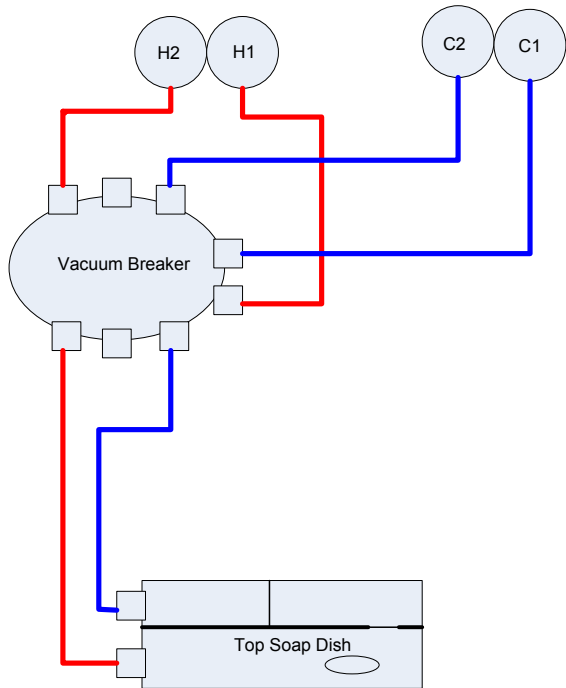
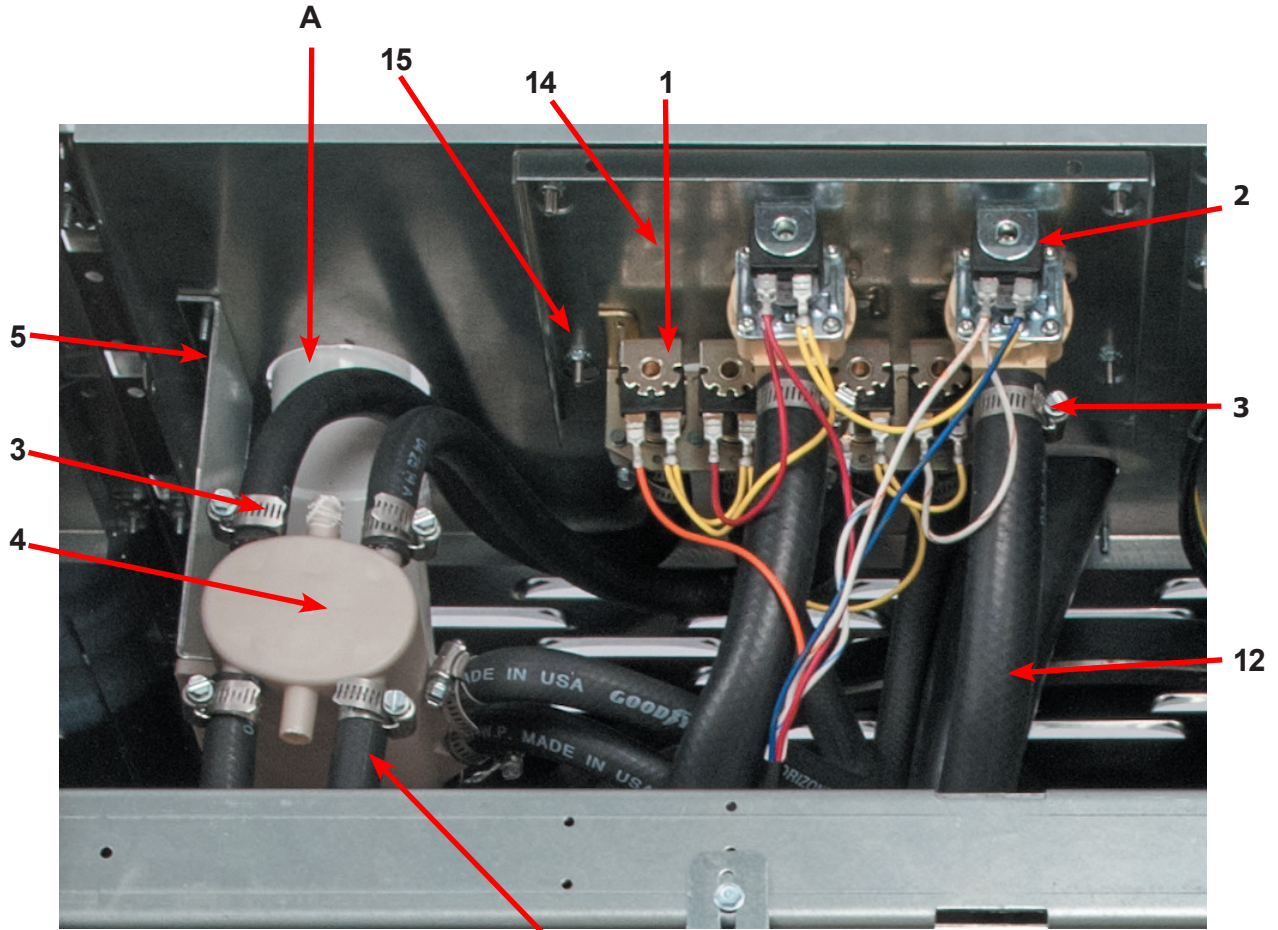

Top Soap Box Design

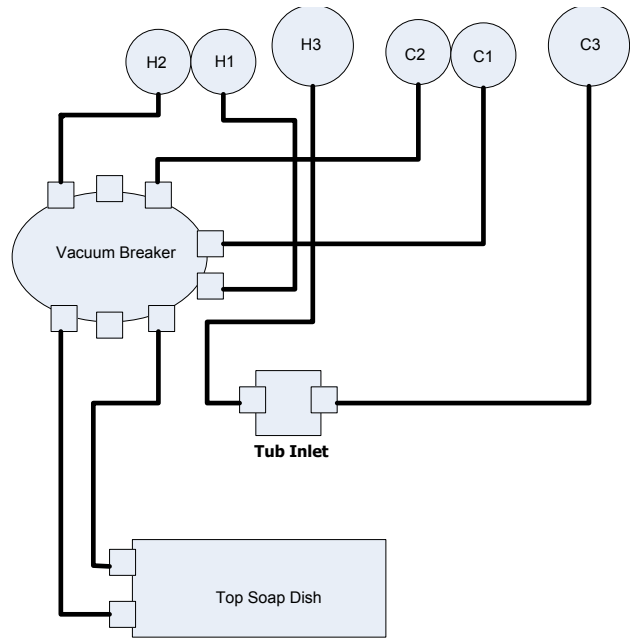

Top Soap Box 4 Valve Design

Water Inlet Part # by Model

Key	Description	T600	T900	T1200	QTY
A	Injector Assembly	9883-009-001	9883-012-001	9885-012-001	1
1	Valve, Water Inlet (dual outlet) (see Water Inlet Valve Breakdown for individual parts)	9379-183-012	9379-183-012	9379-183-012	2
*	Screw, Valve Mtg	9545-008-026	9545-008-026	9545-008-026	2
2	Valve Water Inlet (single outlet)			9379-194-001	2
*	Screw, Valve M4x0.7x8mm			9545-064-001	8
3	Clamp-Water Valves	8654-117-008	8654-117-008	8654-117-008	AR
*	Shield over Water Valves Plastic	9550-194-001	9550-195-001	9550-195-001	1
*	Clip-Push	9083-121-001			3
*	Clip-Push		9083-121-001	9083-121-001	4
4	Vacuum Breaker	9610-001-001	9610-001-001	9610-001-002	1
5	Bracket, Vacuum Breaker	9029-077-001	9029-077-001	9029-077-001	1
*	Screw	9545-008-026	9545-008-026	9545-008-026	4
6	New Front Mount Soap Box, 2 port			9732-290-001	1
7	Fitting, Cross (new soap box)			8615-118-001	
*	Clamp, Vacuum Breaker End	8654-117-014	8654-117-014	8654-117-014	1
9	Hose, Vacuum Breaker to Tub Injection Tube	9242-461-001	9242-461-001	9242-461-001	1
10	Flow restrictor	9475-002-002	9475-002-002	9475-002-002	2
13	Flow restrictor		9475-002-002	9475-002-003	3
14	Plate-Water Valves, Mounting	9452-813-001	9452-814-001	9452-814-001	1
15	Nut, #10-32UNF, 2B	8460-413-002	8460-413-002	8460-413-002	4

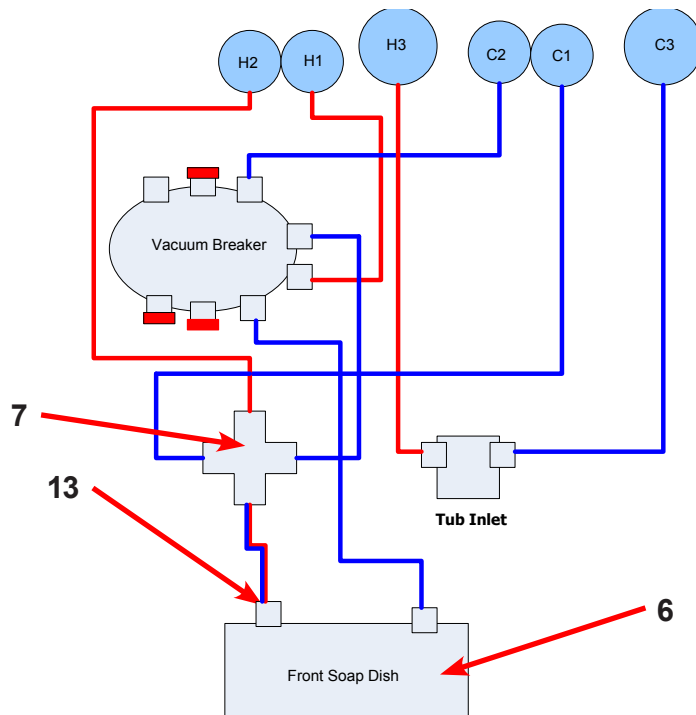

New Front Soap Box Design

Chassis and Drain Part # T-600

Key	Description	T-600	QTY
1	Base Assy,Frame	9945-097-002	1
2	Outer Tub Assy	9930-164-001	1
*	Tub & Cylinder Assy	9869-033-001	1
3	Ring Assy, Tub Mtg-Front	9950-051-004	1
4	Ring Assy.Clamp Tub Mtg.- Rear	9950-056-002	1
5	Bolt, 1/2" x 1 1/4 Rings to Base		4
6	Nut, Wizlock, 1/2-13	8640-417-005	1
7	Hose, Tub to Drain Valve	9242-456-001	1
8	Clamp, Hose (Tub to Drain Valve)	8654-117-014	2
9	Valve, Drain	9379-202-001	1
10	Hose, Drain Valve to Tube	9242-457-001	1
11	Clamp, Hose (Drain Valve to Tube)	8654-117-014	2
12	Bracket, Drain Valve	9029-052-001	1
*	Screw, Valve to Bracket 12ABx1/2	9545-008-026	2
13	Tube Assy, Drain	9915-118-002	1
*	Screw Tube (Bracket to Base 1/4Bx3/4	9545-030-002	2
14	Hose, Overflow to drain	9242-449-002	1
*	Clamp, Overflow	8654-117-018	2
*	Lockwasher	8641-582-018	4
*	Nut, Hex 5/8-11	8640-425-001	4
*	Shim, Support Assembly (thin)	9552-038-001	AR
15	Fill Hose, Vacuum Brkr. to Tub		1
16	Dispenser Soap	9122-005-004	1
17	Gasket, Dispenser	9206-416-001	1
*	Nut Spring SS	8640-399-007	4
*	Screw, Disp. Mtg	9545-008-012	4
*	Hose, Dispenser to Tub	9242-450-001	1
*	Clamp, Dispenser Hose	8654-117-008	2
18	Back Ass'y, Tub	9962-013-001	1
19	Bolt, 7/16" x 2" Tub Back to Tub	9545-029-003	12
20	Nut, Flange Lock	8640-416-005	12
21	Hose, Pressure Switch	9242-175-002	1
*	Clamp, Pressure Switch Hose	8654-117-015	1

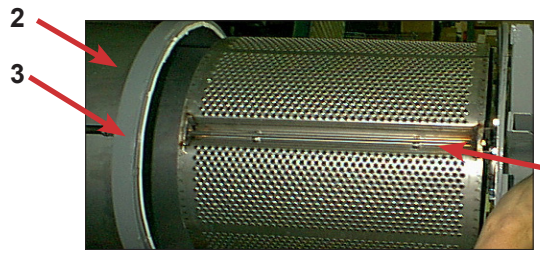
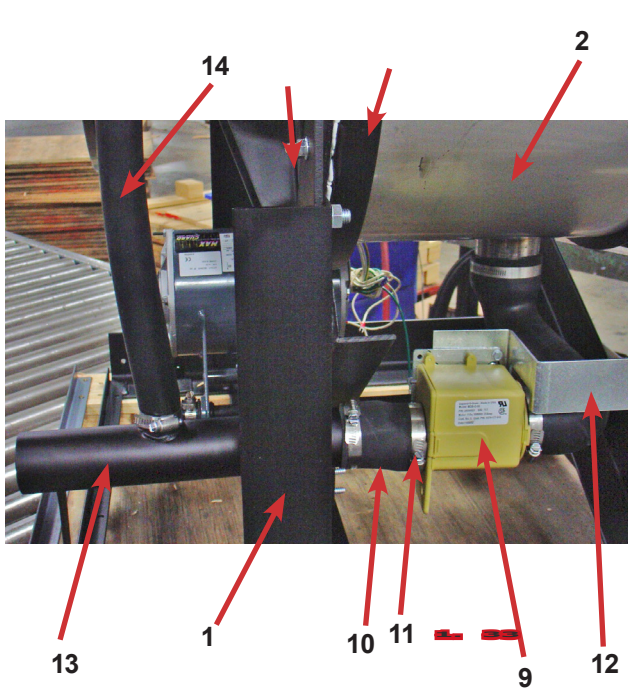

7
Cylinder

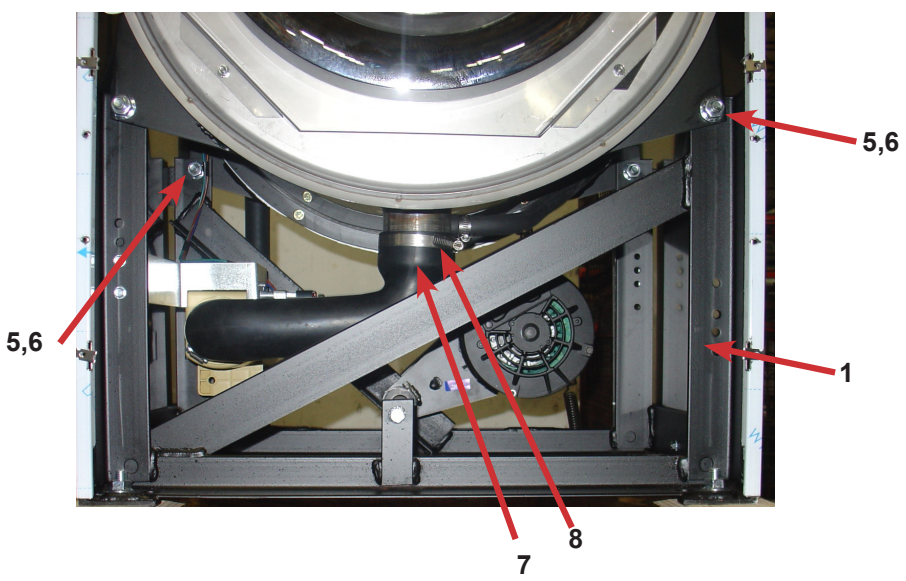
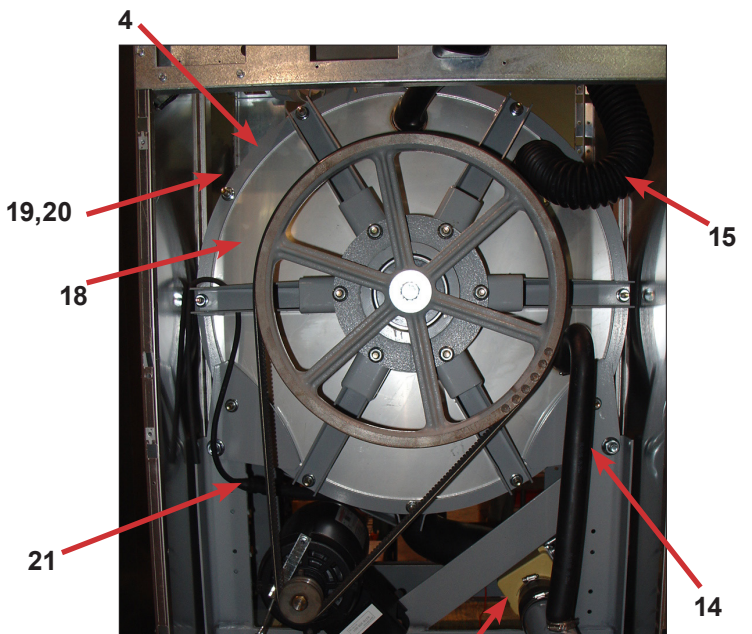

9

Chassis and Drain Part # by Model

Key	Description	T-900	T-1200	QTY
1	Base Assy,Frame	9945-155-002	9945-125-002	1
2	Outer Tub Assy Before Serial #535659	9930-147-001	9930-150-001	1
2	Outer Tub Assy After Serial #535659	9930-158-001	9930-154-001	1
*	Tub & Cylinder Assy Before Serial #535659	9869-023-003	9869-022-001	1
*	Tub & Cylinder Assy After Serial #535659	9869-027-003	9869-022-003	1
3	Tub Front Before Serial #535659	9974-011-001	9974-011-001	1
3	Tub Front After Serial #535659	9974-011-001	9974-011-001	1
*	Gasket, Tub Front	9206-421-002	9206-421-002	1
4	Ring Assy, Tub Mtg-Front Clamp	9950-055-001	9950-055-001	1
5	Bolt, Top Front Ring 3/8"-16 x 3"	9545-029-009	9545-029-009	1
6	Nut WCAD 3/8"-16	8640-415-001	8640-415-001	1
7	Ring Assy.Clamp Tub Mtg. to Frame	9950-053-002	9950-053-002	1
8	Bolt, 1/2" -13 x 2" Ring	9545-017-013	9545-017-013	1
9	Nut, 1/2" -13 Ring	8640-417-005	8640-417-005	1
10	Bolt, 1/2" -13 x 2" Rings to Base	9545-017-013	9545-017-013	2
11	Nut, Wizloc 1/2" x 13	8640-417-005	8640-417-005	2
12	Washer, Flat 1/2"	8641-581-026	8641-581-026	2
13	Hose, Tub to Drain Valve	9242-459-001	9242-459-001	1
14	Clamp, Hose (Tub to Drain Valve)	8654-117-014	8654-117-014	2
15	Valve, Drain	9379-202-001	9379-202-001	1
*	Screw, Valve to Base 1/4Bx3/4	9545-030-002	9545-030-002	2
*	Washer, Flat 1/4	8641-581-018	8641-581-018	2
16	Hose, Drain Valve to Tube	9242-457-001	9242-457-001	1
*	Clamp, Hose (Drain Valve to Tube	8654-117-014	8654-117-014	2
17	Tube Assy, Drain	9915-120-004	9915-126-002	1
18	Clamp, Hose (Tube to Frame Bracket)	8654-117-014	8654-117-014	1
*	Bracket, Drain Tube	9029-162-002		1
*	Screw Tube (Bracket to Base 1/4Bx3/4)	9545-030-002	9545-030-002	4
19	Hose, Overflow Tub To Drain Tube	9242-449-003	9242-449-003	1
*	Clamp, Hose	8654-117-018	8654-117-018	2
20	Tube, Suds overflow	9242-463-004	9242-463-004	1
*	Clamp, Hose	8654-117-008	8654-117-008	2
21	Hose, Pressure switch	9242-175-007	9242-175-004	1
	Clamp, Hose	8654-117-015	8654-117-015	1

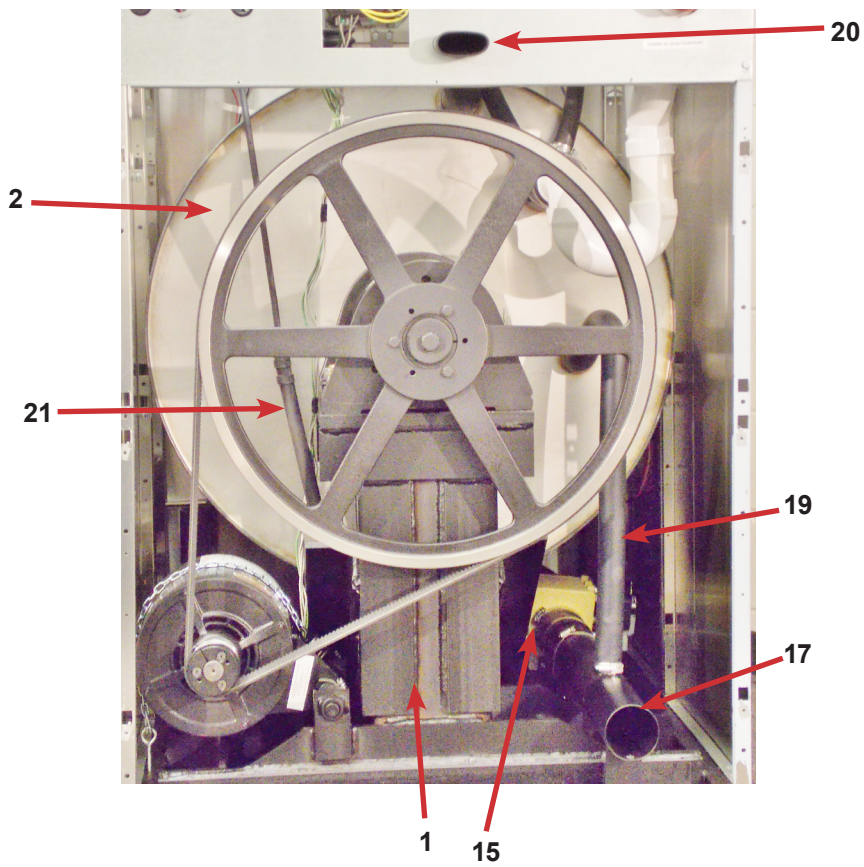
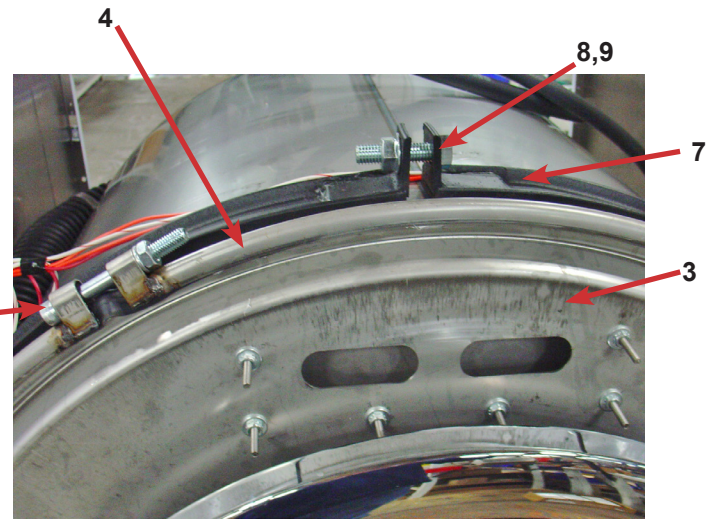
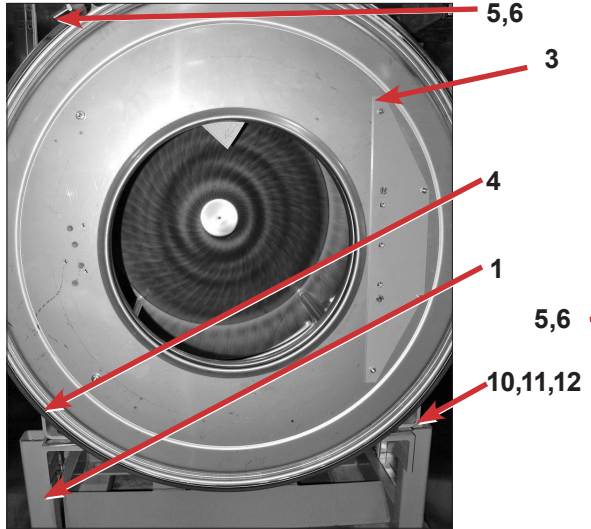
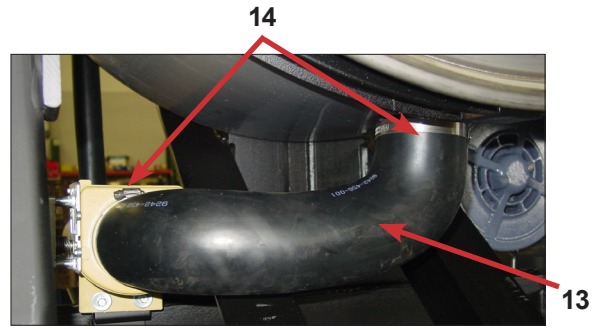
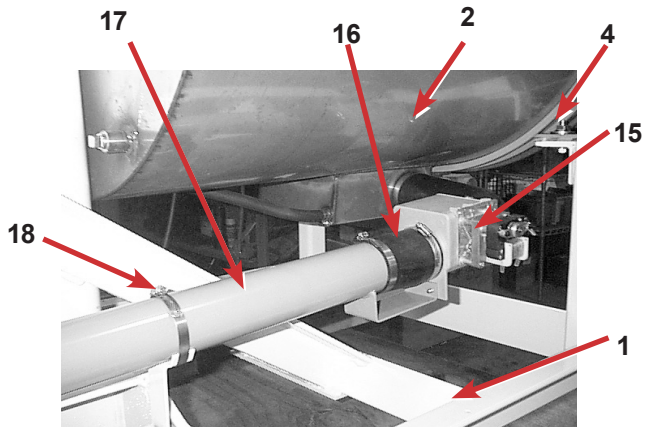

Electrical Components - Top Compartment Mechanical Pressure switch

Key	Description	T-600	T-900	T-1200	QTY
*	Front Panel Control Assembly	9989-463-001	9989-456-001	9989-456-001	1
1	Ribbon Cable	9500-001-001	9500-001-001	9500-001-001	2
2	PCB I/O interface	9799-003-001	9799-003-001	9799-003-001	1
3	PCB CPU (Main Control)	9799-002-003	9799-002-003	9799-002-003	1
4	Harness CPU to I/O Power	9627-706-001	9627-706-001	9627-706-001	1
5	Harness Trough	9627-697-001	9627-697-001	9627-697-001	1
6	Harness Door Lock CPU	9627-837-001	9627-892-001	9627-892-001	1
7	Relay (Run)	5192-285-003	5192-285-003	5192-285-003	1
*	Screws Mtg I/O & CPU	9545-008-001	9454-008-001	9454-008-001	8
*	Diode Wire Assembly	8220-001-442	8220-001-442	8220-001-442	1
8	Pressure Switch	9501-009-003	9501-009-004	9501-009-004	1
*	Bracket Pressure Switch Mtg	9029-071-001	9029-071-001	9029-071-001	1
9	Harness Pressure Switch	9627-704-001	9627-704-001	9627-704-001	1
*	Trough Assy,Controls 208-240 V	9857-214-003	9857-216-005	9857-217-003	1
*	Trough only	9839-014-001	9839-014-001	9839-016-001	1
*	Screw,Trough Sides & Tranformer	9545-008-026	9545-008-026	9545-008-026	7
*	Lockwasher #10	8641-582-006	8641-582-006	8641-582-006	7
10	Angle Support Trough Bracket	9003-061-001	9029-061-001	9029-061-001	1
*	Angle Trough to Rear Channel Bracket	9029-229-001	9003-229-001		1
*	Screw,10Bx1/4 rear channel bracket	9545-008-001	9545-008-001		2
*	Screw, Trough Bracket	9545-008-026	9545-008-026	9545-008-026	3
11	Transformer, Control (Primary Voltage to 115 volts)	8711-004-001	8711-004-001	8711-004-001	1
*	Screw, Mtg #8Bx1/4"	9545-045-001	9545-045-001	9545-045-001	2
*	Lockwasher	8641-582-005	8641-582-005	8641-582-005	2
12	Screw GRN. #10-32x 1/2"	9545-008-027	9545-008-027	9545-008-027	1
*	Lockwasher #10	8641-582-006	8641-582-006	8641-582-006	1
*	Lug, Grounding	8652-130-037	8652-130-037	8652-134-001	1
13	Transformer, Secondary (120v to 12vac)	8711-003-001	8711-003-001	8711-003-001	1
*	Harness Control VF Shield RED	9627-810-001	9627-810-001	9627-810-001	1
*	Bushing 3/4 Trough	9053-067-001	9053-067-001	9053-067-001	1
*	Bushing , Wire 7/8	9053-067-002	9053-067-002	9053-067-002	2
14	Dynamic Braking Resistor	9483-004-002	9483-004-003	9483-004-003	2
15	Screws #10-32x1/2" (pnhdcr) BR	9545-012-008	9545-012-008	9545-012-008	4
15	Nuts, #10-32 UNF 2B BR	8640-413-002	8640-413-002	8640-413-002	4
*	Screw #6-32x5/16"	9545-044-006	9545-044-006	9545-044-006	4
*	Nuts Hex #6-32	8640-411-003	8640-411-003	8640-411-003	4
*	Trml Blok Assy, POWER at rear	9897-033-002	9897-033-002	9897-033-002	1
16	PCB Display	9799-001-001	9799-001-001	9799-001-001	1
17	Harness, CPU to Display	9627-705-001	9627-705-001	9627-705-001	1

Electrical Components - Top Compartment

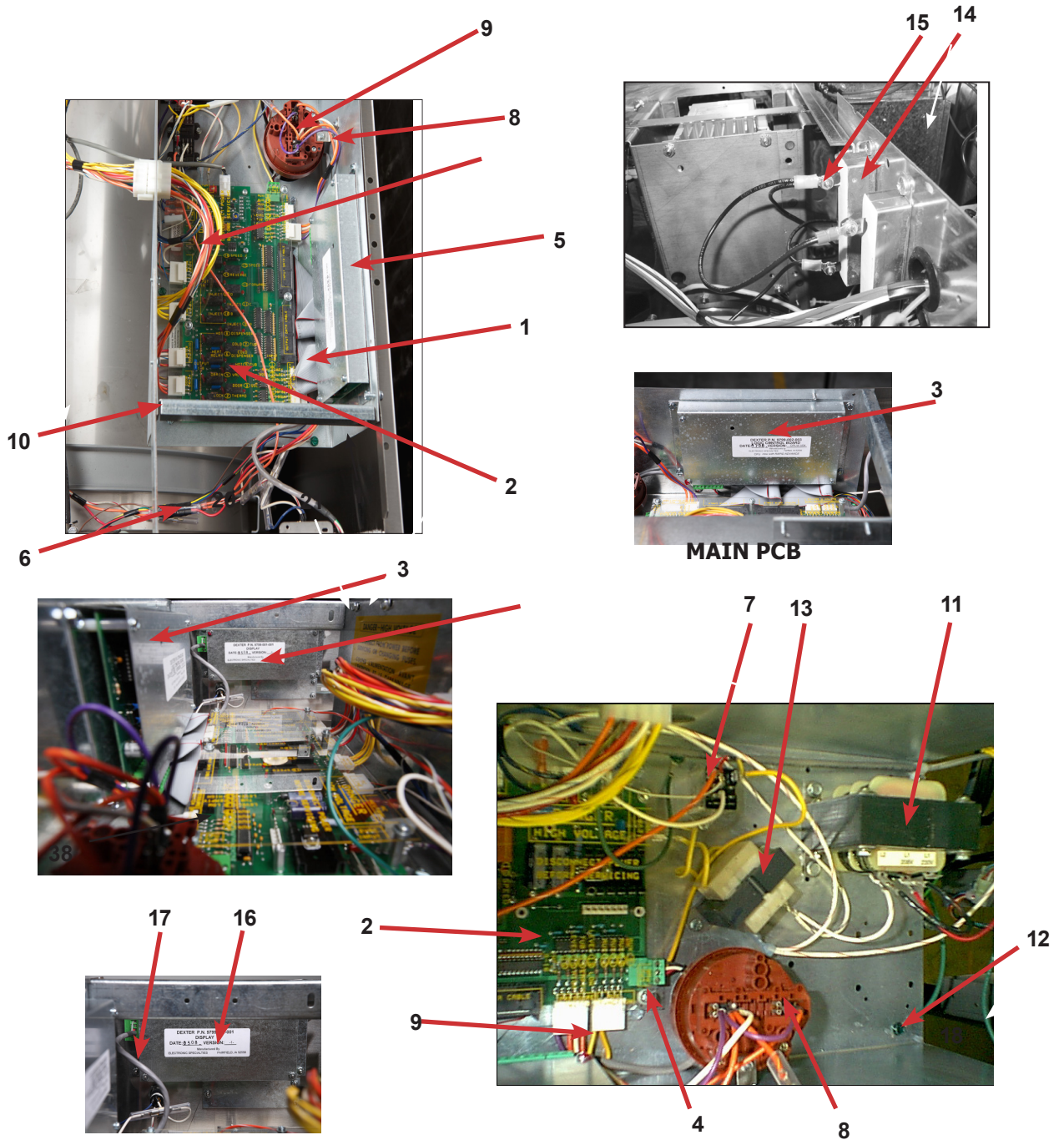

Key	Description	T-600	T-900	T-1200	QTY
*	Harness Power Trml Blok	9627-747-003	9627-747-003	9627-747-002	1
*	Screw #6 AB x 3/4 Mtg Trml Blok	9545-031-001	9545-031-010	9545-031-010	1
*	Screw, Mtg 8Bx3/8"	9545-045-007	9545-045-007	9545-045-007	2
*	Strip, Terminal Marker	9558-025-001	9558-025-001	9558-025-001	1
*	Screw, Mtg #8Bx1/4"	9545-045-001	9545-045-001	9545-045-001	2
*	Terminal Block Assy Injector	9897-032-002	9897-032-002	9897-032-002	1
*	Cover Electrical	9074-267-001	9074-267-001	9074-267-001	1
*	Plastic Shield Over Water Valve	9550-194-001	9550-195-001	9550-195-001	1
*	Standoff Twistlock	9527-002-003	9527-002-003	9527-002-003	2
*	Standoff Twistlock	9527-002-002	9527-002-002	9527-002-002	3

Electrical Components - Top Compartment Electronic Pressure Sensor

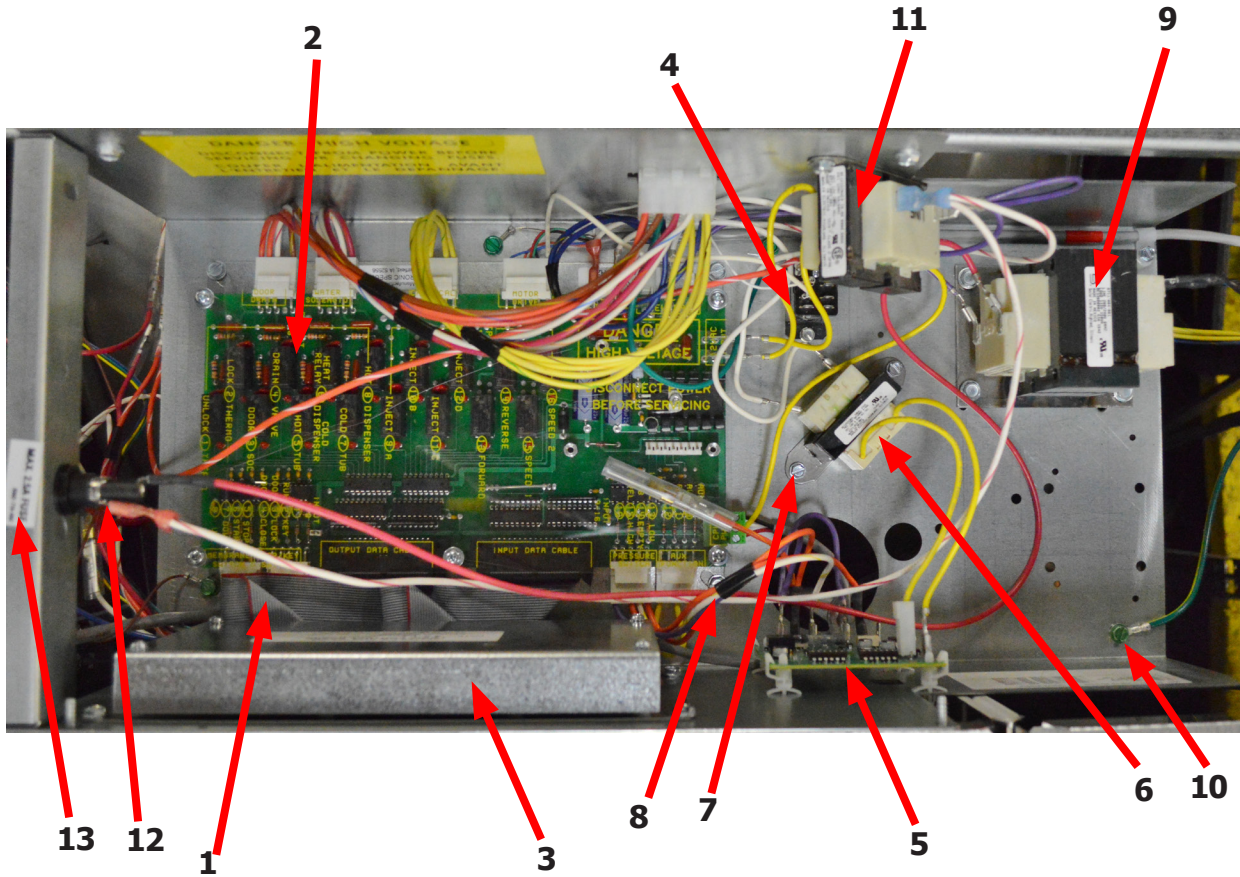

Key	Description	T-600	T-900	T1200	QTY
*	Trough Assy,Controls 208-240 V	9857-214-003	9857-216-005	9857-217-003	1
*	Trough only	9839-014-001	9839-014-001	9839-016-001	1
*	Screw,Trough Sides & Tranformer	9545-008-026	9545-008-026	9545-008-026	7
*	Lockwasher #10	8641-582-006	8641-582-006	8641-582-006	7
1	Ribbon Cable	9500-001-001	9500-001-001	9500-001-001	2
2	PCB I/O interface	9799-003-001	9799-003-001	9799-003-001	1
3	PCB CPU (Main Control)	9799-002-003	9799-002-003	9799-002-003	1
*	Harness CPU to I/O Power	9627-706-001	9627-706-001	9627-706-001	1
*	Harness Trough	9627-697-001	9627-697-001	9627-697-001	1
*	Harness Door Lock CPU	9627-837-001	9627-892-001	9627-892-001	1
4	Relay (Run)	5192-285-003	5192-285-003	5192-285-003	1
*	Screws Mtg I/O & CPU	9454-008-001	9454-008-001	9454-008-001	8
*	Diode Wire Assembly	8220-001-442	8220-001-442	8220-001-442	1
*	Kit-Pressure Sensor, Electronic	9732-314-002	9732-314-002	9732-314-002	1
5	Kit-Repaacement, Pressure Sensor (only)	9732-315-001	9732-315-001	9732-315-001	1
*	Support-PCB, 3/8", Edge Holding	9458-285-001	9458-285-001	9458-285-001	4
6	Transformer-120/18VAC, 5 VA	8711-015-001	8711-015-001	8711-015-001	1
7	Screw, 8B x 1/4"	9545-045-001	9545-045-001	9545-045-001	2
*	Wire Assy BLK/BLU	8220-001-233	8220-001-233	8220-001-233	1
*	Wire Assy RED/BLU	8220-001-232	8220-001-232	8220-001-232	1
8	Harness Pressure Switch	9627-704-001	9627-704-001	9627-704-001	1
*	Angle Support Trough Bracket	9029-061-001	9029-061-001	9029-061-001	1
*	Angle Trough to Rear Channel Bracket	9003-229-001	9003-229-001		1
*	Screw,10Bx1/4 rear channel bracket	9545-008-001	9545-008-001		2
*	Screw, Trough Bracket	9545-008-026	9545-008-026	9545-008-026	3
9	Transformer, Control (Primary Voltage to 115 volts)	8711-004-001	8711-004-001	8711-004-001	1
*	Screw, Mtg #8Bx1/4"	9545-045-001	9545-045-001	9545-045-001	2
*	Lockwasher	8641-582-005	8641-582-005	8641-582-005	2
10	Screw GRN. #10-32x 1/2"	9545-008-027	9545-008-027	9545-008-027	1
10	Lockwasher #10	8641-582-006	8641-582-006	8641-582-006	1
10	Lug, Grounding	8652-130-037	8652-130-037	8652-134-001	1
11	Transformer, Secondary (120v to 12vac)	8711-003-001	8711-003-001	8711-003-001	1
*	Harness Control VF Shield RED	9627-810-001	9627-810-001	9627-810-001	1
*	Bushing 3/4 Trough	9053-067-001	9053-067-001	9053-067-001	1
*	Bushing , Wire 7/8	9053-067-002	9053-067-002	9053-067-002	2
*	Dynamic Braking Resistor	9483-004-002	9483-004-003	9483-004-003	2
*	Screws #10-32x1/2" (pnhdcr) BR	9545-012-008	9545-012-008	9545-012-008	4
*	Nuts, #10-32 UNF 2B BR	8640-413-002	8640-413-002	8640-413-002	4
*	Screw #6-32x5/16"	9545-044-006	9545-044-006	9545-044-006	4
*	Nuts Hex #6-32	8640-411-003	8640-411-003	8640-411-003	4
*	Trml Blok Assy, POWER at rear	9897-033-002	9897-033-002	9897-033-002	1
*	Harness, CPU to Display	9627-705-001	9627-705-001	9627-705-001	1
12	Fuse Holder Assy	9200-001-002	9200-001-002	9200-001-002	
*	Fuse, 1.5Amp	8636-018-001	8636-018-001		
*	Fuse, 2.5Amp			8636-018-004	
13	Label-Fuse, 1.5Amp	8502-716-001	8502-716-001		
13	Label-Fuse, 2.5Amp			8502-716-002	

WN0900XA-12EN2X-SSKCS-USX

Schematic/Diagram

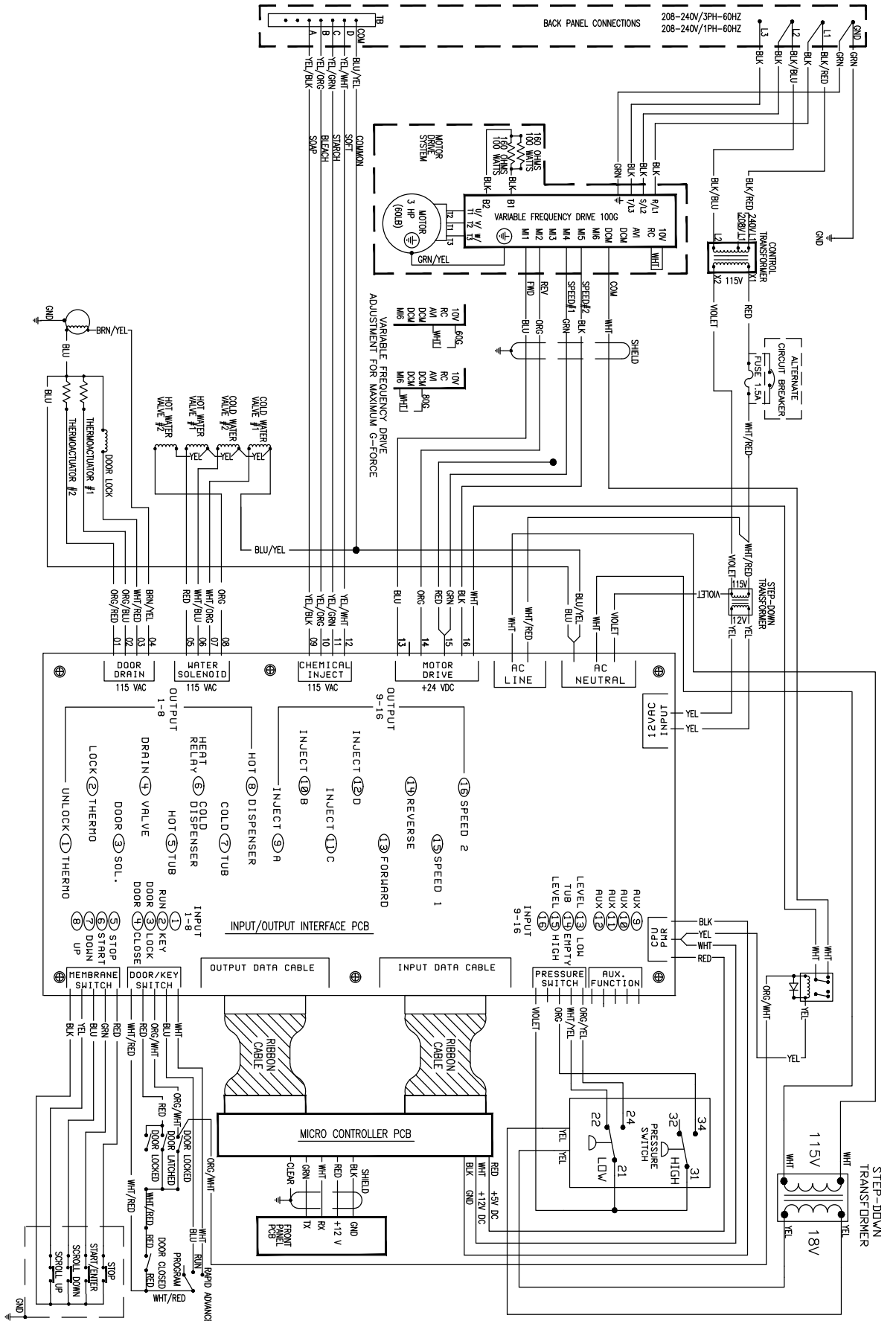

SCHEMATIC/WIRING DIAGRAM 208 - 240V, 3/1PH, 60 HZ

P/N 9506-763-001PR
 60 LB OPL. VF DRIVE, 208-240V, 30 CYCLES
 WN0900XA-12-N-X-_____X

WN1200XA-12EN2X-SSKCS-USX

Schematic/Diagram

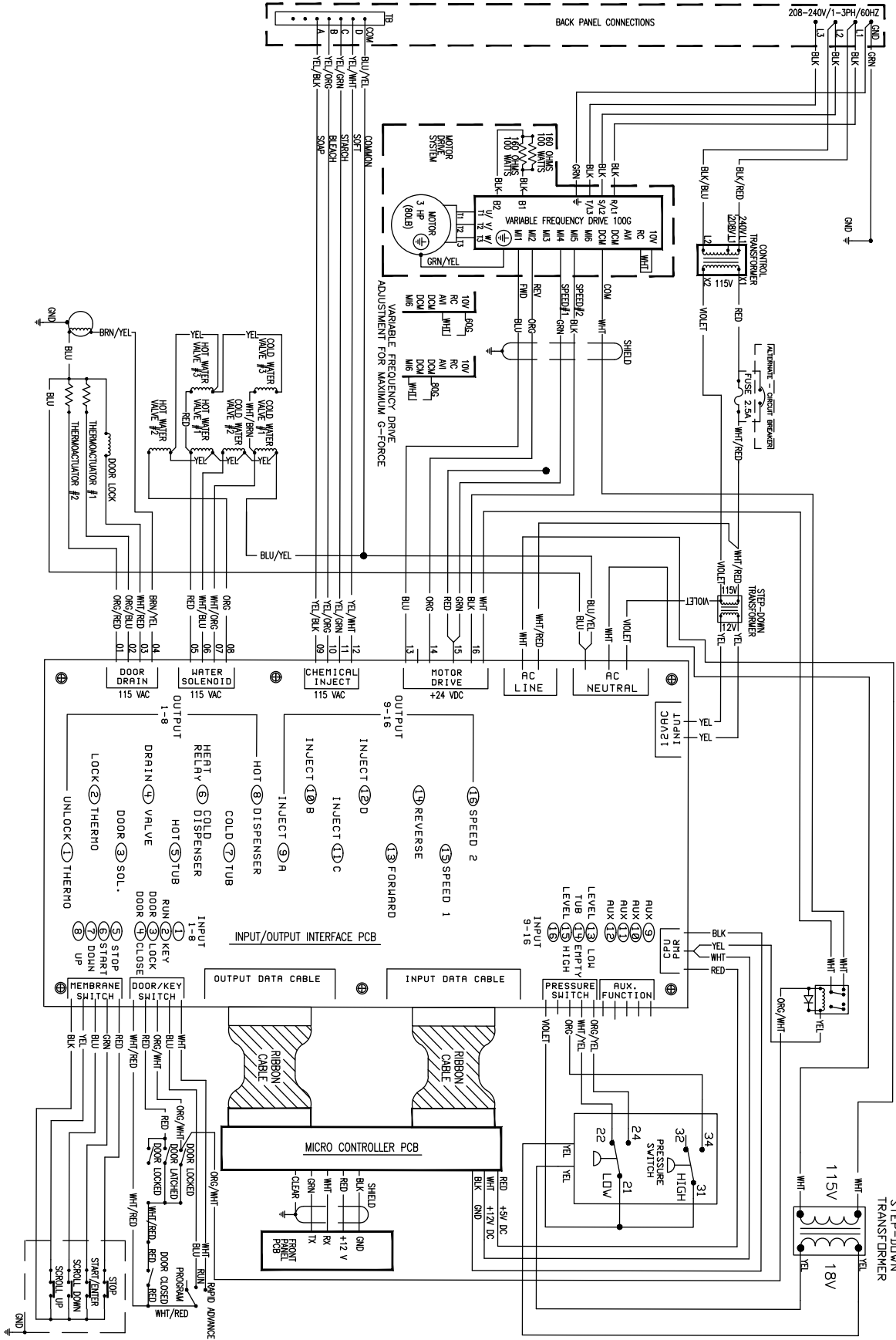

P/N 9506-771-001PR
 80 LB OPL. VF DRIVE, 208-240V, 30 CYCLES
 WN1200XA-12_N_X-____X
 SCHEMATIC/WIRING DIAGRAM 208 - 240V, 3/1PH, 60 HZ

Section 7:

Electric Heated Models

Machine Operation

Programmed temperatures will be displayed in CENTIGRADE only. The electric heaters will turn on when low water level has been obtained and actual temperature is less than programmed temperature. While the heaters are engaged the cylinder will pause 3 minutes between each forward/ reverse rotation. The cylinder will resume normal operation when bath temperature is 5 degrees before the programmed temperature is reached. Cycle countdown time display will stop while heaters are engaged. Heaters will maintain temperature throughout heated baths and will engage when bath temperature drops below 3 degrees of programmed temperature. Actual temperature may be displayed by pressing the start and down arrows simultaneously. The temperature light will be on whenever the temperature is being displayed and will continue to be displayed until the start button is pushed again to display time remaining.

Any temperature between 20 degrees and 90 degrees in 5 degree increments is programmable. Any bath that has a programmed spin cycle will go through a short cool down bath before spinning if the actual bath temperature at the time of draining is above 65 degrees . This bath consists of filling tub to low level with WARM water while tumbling and then draining. This will continue until bath temperature is below 65 degrees If machine stop button is pressed momentarily (soak condition) while the heaters are energized, the cylinder will continue with the 3 minute pause between each forward / reverse rotation until the set temperature has been reached. The normal 15 minute pause between each forward/reverse rotation will then take place until the start button is pushed to resume the cycle. Actual bath water temperatures will normally overshoot the set temperature by 1 degree to 3 degree. This is to assure set temperature will be maintained throughout a normal bath time of 10-20 minutes. The heaters will engage if the bath temperature drops below 3 degrees of set temperature.



Heated Machine Programming

The heated bath is programmed in our water temperature selection portion of our microprocessor. You will program a formula the same way as perviously discussed in this manual except as follows:

When you arrive at temperature selection portion of programming you will see the following choices: EE (tub empty), CC (cold), CH (warm), HH (hot), or any temperature between 20 degrees and 90 degrees in 5 degree increments. Use the up arrow and down arrow pad to set the water temperature desired (Centigrade) and then push the green start button to accept the change and then move to the next programming sequence. Continue with any other cycle changes as previously discussed.

To exit the program mode and accept all changes press the red stop button while any one of the nine bath lights (top row of lights) are lit. The "Select cycle" light should be on. Turn the run/program key back to run position. If the program mode is exited incorrectly, the "Program" light will remain lit and the machine will remain in the program mode until the run/program key is turned back to the program position and the program is exited correctly.

Features

When a numeric value for temperature is programmed for any bath the water valve selection to fill that bath is chosen as follows:

- 20 degrees - 35 degrees Centigrade Cold valve only will be used
- 40 degrees - 60 degrees Centigrade Cold and Hot Valve will be used
- 65 degrees - 90 degrees Centigrade Hot valve only will be used

The machine will have 6 or 9 heating elements The temperature control and display are operated with a temperature control circuit board on the I/O board, a thermistor sensor in the tub back, and a computer logic board (CPU).

The control voltage is 115 vac (60hz) or 24 vac (50hz) to heat relay. Machine available in 208/240 vac 3 phase (60hz), 380/415 vac 3 phase (50hz) ONLY. Optional Temperature control board can be added for non-heated machines to display temperatures and Steam option kit available. Steam valve will operate the same as described throughout except valve will operate in place of heat relay.

Troubleshooting

If the heater relay does not engage in a heated bath:

Check the calibration switch is set to run position, Check that I/O board jumpers are changed to the level side, Jumper must start closest to level input light and open pin will be towards door input lights.

Check actual water temperature is less than programmed temperature

Check the temperature sensor for open circuit or shorted

Check low level contacts on the pressure switch not closing

Check low level safety relay contacts not closing or bad contacts

Check low level safety relay coil

Check heater relay contacts not closing or bad contacts

Check wiring between temperature board and sensor at all connectors and inspect wires for any damage.

If temperature control board is removed, the programmed temperature value is retained in all baths and the water valves to fill that bath are chosen based on the programmed temperature as described on previous feature page.

Calibration

The calibration should be checked whenever a temperature sensor has been replaced or if actual water temperature varies significantly from the display. To calibrate the temperature control board go to step #15 of the diagnostic cycle (#31). Actual temperature will be shown in display. On the temperature control board move the cal-run switch to the calibrate position. The factory set calibration temperature of 98 degrees C should show on the display after a few seconds. Now turn the adjusting screw clockwise to increase calibration point and display temperature or counterclockwise to decrease calibration point and display temperature. The display is updated every 5 seconds so make adjustments in very small increments. Be sure to allow ample time for display to respond to updates. If adjustments of higher than 100 degrees C only the last two digits will be displayed.

208-240 vac 3 phase (60hz) 308-415 vac 3 phase (50hz) power is supplied on L-1, L-2, L-3 to the normally open contacts of the heat relay and then to the six heating elements. The elements are wired in star or wye on 50HZ models. A delta configuration is used on 60HZ models. There is a potential 220 volts across each element for both models 60HZ or 50HZ. Control voltage 115 vac (60hz) or 24 vac (50hz) is used to power the heat relay coil and will close the heat relay contacts. The supply voltage will initiate from the I/O board Terminal number #6 (wht/blue wire) through the low-level safety relay contacts and then to the heat relay operating coil when heat is being called for by temperature board. The neutral will be supplied from the (blu/yel) wire connected to AC neutral terminal on the I/O board. The low level safety relay coil will operate when the washer has filled to a level, and gets a signal from the pressure switch. That signal will be 24 VDC and comes from the CPU board and through the pressure switch.

With the low level safety relay contacts now switched and closed, voltage now passes to the heat relay operating coil, and allow main 3 phase voltage across the heating elements. Control voltage 115 vac (60hz) is used to power the steam valve coil. The supply voltage will initiate from the I/O board Terminal number 6 (wht/blue wire) to the heat relay coil when heat is being called for by temperature board. The neutral will be supplied from the (blu/yel) wire connected to AC neutral terminal on the I/O board. The valve gets a signal from the pressure switch. That signal will be 24 VDC and comes from the CPU board and through the pressure switch. With the low level safety relay contacts now switched and closed, voltage now will pass to the heat relay operating coil, and allow main 3 phase voltage across the heating element.

Electric Heated Chassis & Frame Hardware Group 60hz

Key	Description	T-600	T-900	T-1200	QTY
1	Outer Tub Assy	9930-165-001	9930-158-002	9930-154-002	1
2	Tub & Cylinder Assy	9869-033-002	9869-027-005	9869-022-004	1
*	Bracket Shield Mtg	9029-095-001	9029-095-001	9029-095-001	1
3	Cover - Heater terminals	9074-331-001	9074-330-001	9074-330-001	1
*	Nuts #10-32UNF	8640-413-002	8640-413-002	8640-413-002	3
*	Screw #10Bx1/2	9545-008-026	9545-008-026	9545-008-026	3
*	Screw #10-32x1/2	9545-012-003	9545-012-003	9545-012-003	3
*	Screw 6Bx3/8	9545-031-003	9545-031-003	9545-031-003	2
*	Screw 6ABx3/4	9545-031-010	9545-031-010	9545-031-010	2
*	Screw 6-32x1/4	9545-044-004	9545-044-004	9545-044-004	3
4	Hose, Tub to Drain	9242-456-002	9242-459-001	9242-459-001	1
*	Bracket Shield R H	9029-193-001		9029-095-001	1
*	Screw #8-32x3/4"	9545-010-001	9545-010-001	9545-010-001	3

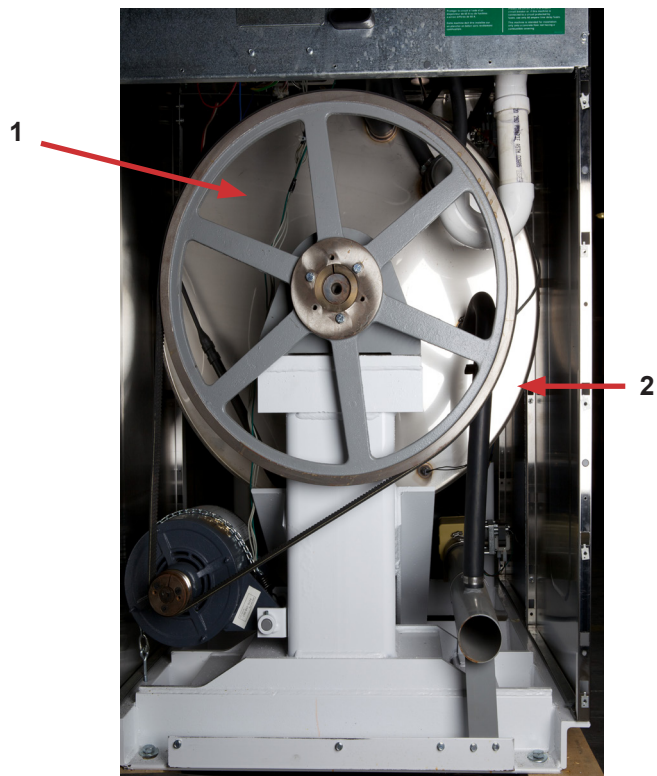
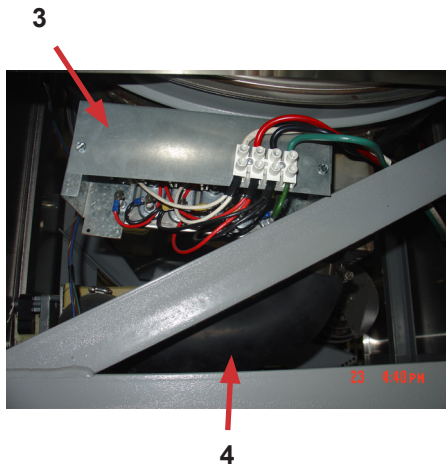

Electric Heated Terminal Block Group

Key	Description	T-600	T-900	T-1200	QTY
*	Terminal Block, power	9897-033-002	9897-033-002	9897-033-002	1
*	Terminal Marker Strip	9558-025-001	9558-025-001	9558-025-001	1
*	Screw	9545-031-010	9545-031-010	9545-031-010	2
*	Terminal Block, Injector	9897-032-002	9897-032-002	9897-032-002	1
*	Terminal Marker Strip	9558-028-001	9558-028-001	9558-028-001	1
*	Screw	9545-053-002	9545-053-002	9545-053-002	2

Electric Heated Labels Group

Key	Description	T-600	T-900	T-1200	QTY
1	Label, Warning Door Opening	8502-757-001	8502-757-001	8502-757-001	1
*	Label, High Voltage	8502-614-004	8502-614-004	8502-614-004	3
2	Label, Connections- Injector	8502-647-002	8502-647-002	8502-647-002	1
*	Label, Connections- Electrical	8502-649-001	8502-649-001	8502-649-001	1
*	Label, Fusing & Installation	8502-619-006	8502-619-006	8502-619-007	1
*	Label, Warning	8502-639-001	8502-639-001	8502-639-001	1
*	Label, Insturction Dispenser	8502-650-001	8502-650-001	8502-650-001	1
*	Label, Installer Instructions	8502-653-001	8502-653-001	8502-653-001	1
*	Label, Injector assembly	8502-666-001	8502-666-001	8502-666-001	1
	Instructions Chemical hose installation	8507-268-001	8507-268-001	8507-268-001	1
	Instructions Spin Direction	8507-274-001	8507-274-001	8507-274-001	1
	Schematic/Wirng Diagram	9506-571-001	9506-573-001	9506-576-001	1
	Owners Booket	8514-241-001	8514-244-001	8514-246-001	1

Electric Heated Wiring Harness Group

Key	Description	T-600	T-900	T-1200	QTY
	Wiring Harness, VFD Control Shield	9627-810-001	9627-810-001	9627-701-001	1
	Wiring Harness, Pressure Switch	9627-704-001	9627-704-001	9627-704-001	1
	Wiring Harness Door /Lock -Keylock	9627-837-001	9627-892-001	9627-892-001	1
	Wiring Harness CPU to Display	9627-705-001	9627-705-001	9627-705-001	1
	Wiring Harness Membrane Switch	9627-700-001	9627-700-001	9627-700-001	1
	Wiring CPU to I/O board	9627-706-001	9627-706-001	9627-706-001	1
*	Wiring Harness, Power Term Blk	9627-748-001	9627-748-002	9627-876-001	1
*	Wiring Harness, Main Heater Assembly	9627-755-001	9627-755-001	9627-755-001	1
*	Wiring Harness, Temp Sensor	9627-762-001	9627-762-001	9627-762-001	1
	VFD to Motor Drive	9627-742-001	9627-742-001	9627-742-001	1
	Wiring Harness, Trough, 115VAC	9627-697-001	9627-697-001	9627-697-001	1
	Wiring Harness, 115VAC	9627-698-001	9627-698-001	9627-698-001	1
	Wiring Harness Control to VFD	9627-710-001	9627-710-001	9627-710-001	1
	Clamp, Cable- 3/16 Dia	8654-125-005	8654-125-005	8654-125-005	1

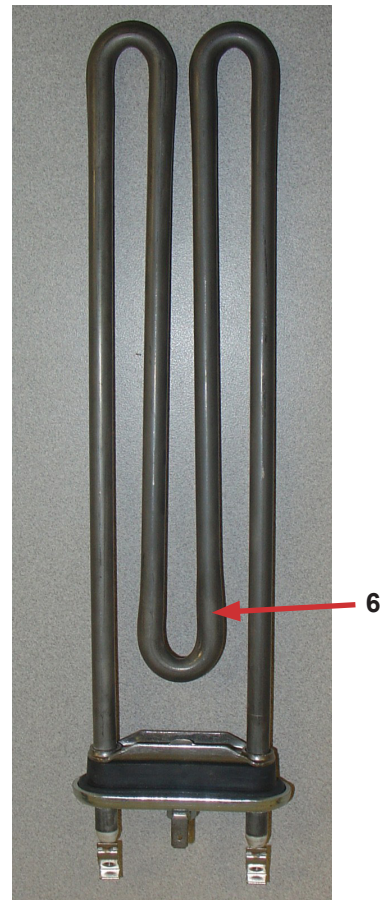
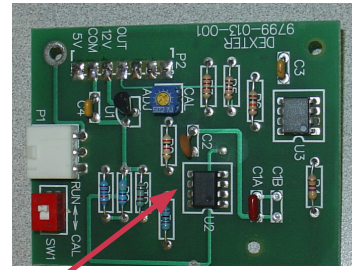
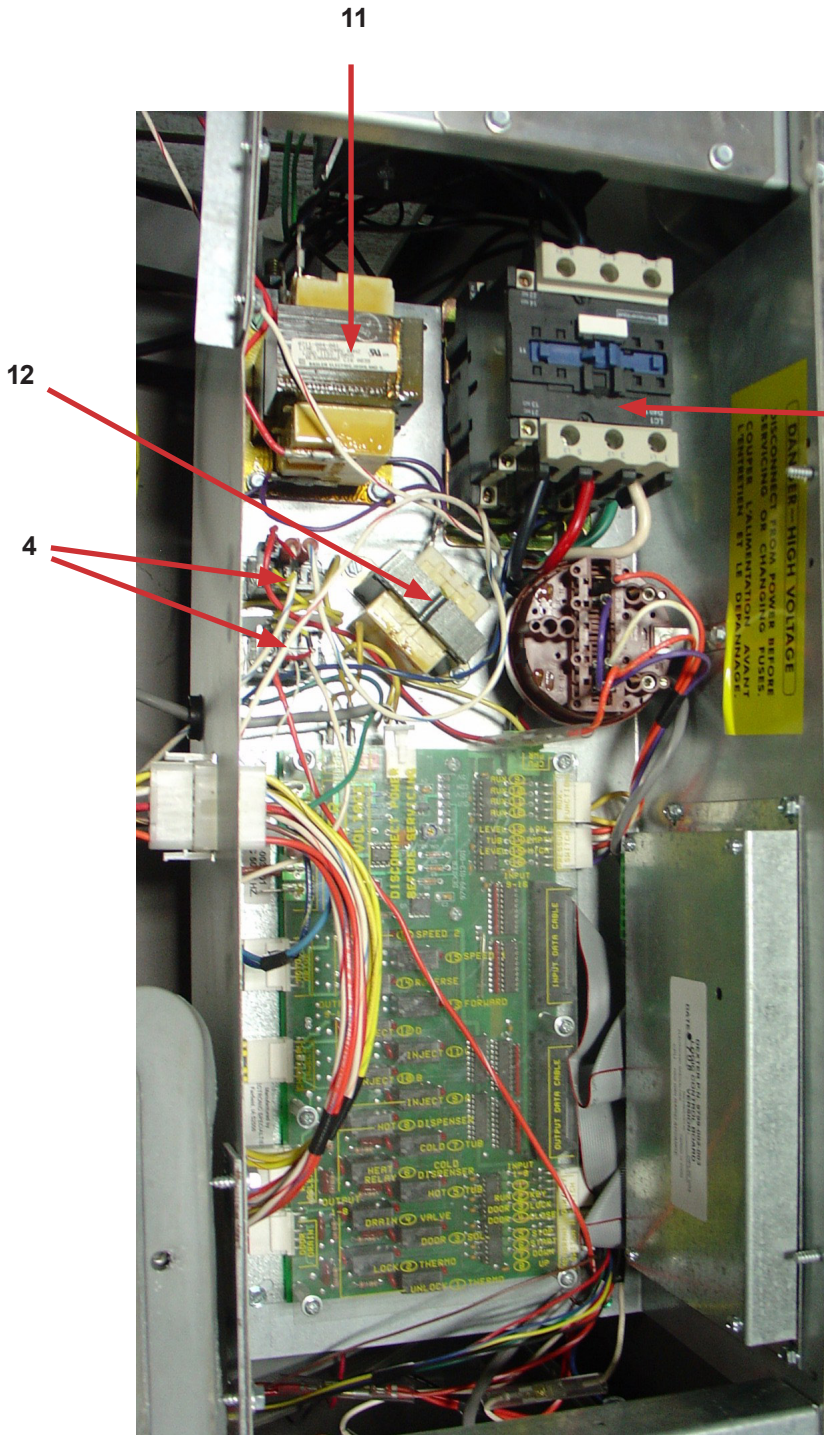

Heated Washer Electrical Components

Key	Description	T-600	T-900	T-1200	QTY
1	Control assembly Trough	9857-214-005	9857-216-009	9857-217-005	1
2	Sensor Assembly	9501-005-002	9501-005-002	9501-005-002	1
3	PC Board Assembly -Temperature Control	9799-013-001	9799-013-001	9799-013-001	1
*	Screw	9545-044-004	9545-044-004	9545-044-004	3
*	Terminal - Lug	8652-134-002	8652-134-002	8652-134-002	1
*	Terminal Block Assy Power	9897-033-002	9897-033-002	9897-033-002	1
4	Run Relay (R-1) and level relay	5192-285-003	5192-285-003	5192-285-003	2
*	Diode Ass'y	8220-001-442	8220-001-442	8220-001-442	2
*	Wire Assembly-WHT/BLU, 28"	8220-063-003	8220-063-003	8220-063-003	1
*	Wire Assembly-WHT/BLU, 10"	8220-078-006	8220-078-006	8220-078-006	1
*	Wire Assy -Jumper, YEL	8220-083-001	8220-083-001	8220-083-001	1
5	Heat Relay 60 amp	5192-291-001	5192-291-001	5192-291-001	1
*	Wire Assembly-BLU/YEL, 12"	8220-064-001	8220-064-001	8220-064-001	1
6	Heater Element	9870-087-001			6
6	Heater Element		9870-087-001	9870-087-001	9
7	Wire Assy -Jumper, BLK 4-8	8220-085-001	8220-085-001	8220-085-001	3
8	Wire Assy -Jumper, RED 6-8	8220-085-002	8220-085-002	8220-085-002	3
9	Wire Assy -Jumper, WHT 4-8	8220-085-003	8220-085-003	8220-085-003	3
*	Strip, Terminal Marker (Power)	9558-025-001	9558-025-001	9558-025-001	1
*	Strip, Terminal Marker Injector (120 volts signals)	9558-028-001	9558-028-001	9558-028-001	1
*	Screw, Mtg	9545-031-010	9545-031-010	9545-031-010	
10	Wire Assy- Green 4"	8220-001-484			5
10	Wire Assy- Green 4"		8220-001-484	8220-001-484	8
*	Wire Assy-Green 11"	8220-064-055	8220-064-055	8220-064-055	1
*	Wire Assy- RED 9"	8220-063-002	8220-063-002	8220-063-002	1
11	Transformer, Control (Primary Voltage to 115 volts)	8711-004-001	8711-004-001	8711-004-001	1
12	Transformer, Secondary (120v to 12vac)	8711-003-001	8711-003-001	8711-003-001	

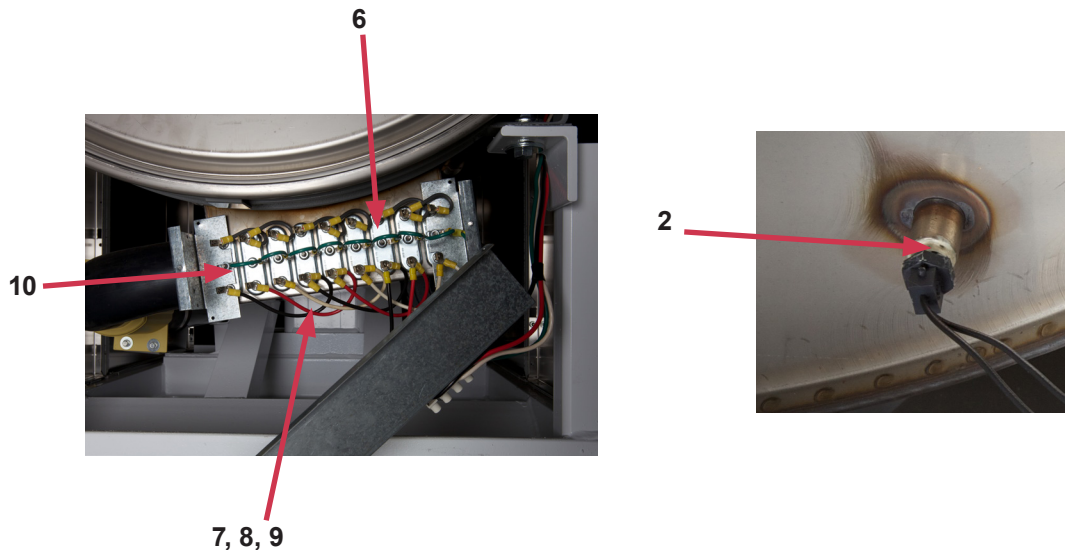

WN0600EA - 13XN

SCHEMATIC/WIRING DIAGRAM 208-240V/3PH, 60 HZ

40# COMPUTER WASHER W/HEAT OPTION

9345-909-001J

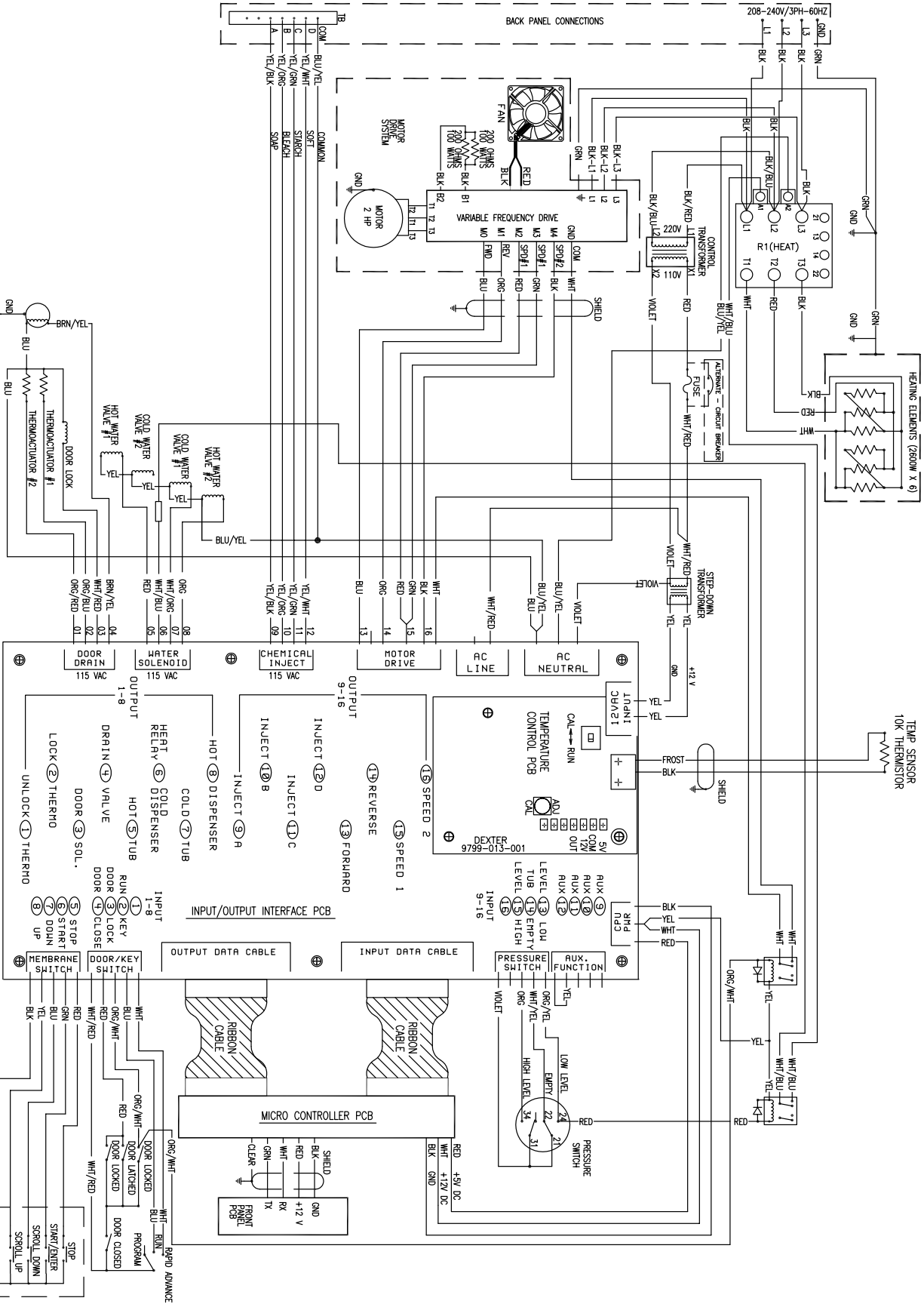

Section 8:

Steam Heated

Valve Kit

Steam Injection Kit for OPL Computer Washers (Only to be installed on Heated Tub Models Design)

Parts for Kit 9732-259-001, -002

KEY	Part Description	T600	T900	T1200	Qty
	Valve-steam , 3/8 pilot (60 Hz only)	9379-189-001	9379-189-001	9379-189-001	1
	Valve-steam , 3/8 pilot (50 Hz only)	9379-189-002	9379-189-002	9379-189-002	1
	Hose assemblyBsteam, 3/8	9990-034-002	9990-034-002	9990-034-002	1
	Tube assy-baffle, steam	9915-123-001	9915-123-001	9915-123-001	1
	PCB assy-temp control	9799-013-001	9799-013-001	9799-013-001	1
	Sensor assy-thermistor,10k	9501-005-002	9501-005-002	9501-005-002	1
	Wiring harness-temp control	9627-762-001	9627-762-001	9627-762-001	1
	Bushing-reducer, hex	8615-104-043	8615-104-043	8615-104-043	1
	Bracket-steam valve	9029-125-001	9029-125-001	9029-125-001	1
	Clamp-st st worm, 1 3/4	8654-117-016	8654-117-016	8654-117-016	1
	Screw-hx hd, #10 AB x 1/2	9545-008-026	9545-008-026	9545-008-026	2
	screw-pan hd, #6-32	9545-044-004	9545-044-004	9545-044-004	3
	Schematic / Diagram	9506-343-001	9506-344-001	9506-345-001	1

To Install:

- 1) Remove electrical power from the machine.
- 2) Remove top panel, rear panel, and lower service door.
- 3) Remove the 2" pipe plugs from the couplings in the tub back (Fig. 1) and the sump (Fig. 2).
- 4) Using Teflon tape on the threads, screw the reducer bushing into the coupling at the bottom of the tub back. (Fig. 3)
- 5) Seal the temperature sensor threads with Teflon tape and install into the reducer bushing. (Fig. 3)
- 6) Plug in one end of the sensor wiring harness to the temperature sensor. (Fig. 3)
- 7) In the control box, remove the I/O board cover and plug the temperature control board into the appropriate socket in the I/O board. Attach the temperature control board to the standoffs in the I/O board with the three screws provided. (Fig. 4)
- 8) Replace the I/O board cover and attach the remaining end of the temperature sensor wiring harness into the temperature control board socket. Route the harness away from all moving parts and wire tie as needed. (Fig. 4)
- 9) Seal threads of steam baffle assembly with Teflon tape and install it into the coupling on the side of the sump. Align the holes in the baffle to run from the front to the rear of the sump. (Fig. 5)
- 10) Unscrew the worm clamp provided and place it around the body of the steam valve just below the steam valve solenoid housing. Reattach the clamp ends and attach the steam valve to the steam valve bracket by sliding the worm clamp over the notches in the bracket and tightening the worm clamp screw. (Fig. 6)
- 11) Seal threads of steam hose ends and attach the end without the union to the outlet side of the steam valve. (Fig. 6)
- 12) Attach the steam valve bracket to the side panel flange at the rear of the washer, just below the rear channel with the #10 sheet metal screws provided. (Fig. 6)
- 13) Screw the coupling end of the steam hose into the threaded end of the steam baffle. (Fig. 7)
- 14) Attach the green ground wire from the steam valve solenoid to the ground lug in the wiring connection area at the rear of the machine.
- 15) Attach one control lead of the steam valve solenoid to the common connection of the soap injection terminal block.
- 16) Disconnect the wht/blu signal wire from the cold-flush water valve solenoid (output #6 on the I/O board) and connect it to the remaining control lead for the steam valve solenoid.
(NOTE: cold water flush to soap box in final rinse is eliminated)
- 17) Attach user-supplied steam pipe to the inlet side of the steam valve.
(NOTE: manual shut off valve and union coupling connection recommended for easier servicing)
- 18) Cut relief notch for steam pipe in corner of back panel before replacing.

Optional Steam Valve Kit

Features

When the numeric temperature value is programmed for any bath, the water valve selection to fill that bath is chosen as follows:

20 degrees - 35 degrees Centigrade	Cold valve only will be used
40 degrees - 60 degrees Centigrade	Cold and Hot valve will be used
65 degrees - 90 degrees Centigrade	Hot valve only will be used

The temperature control and display are controlled using the temperature control circuit board on the I/O board, the thermistor sensor in the tub back, and the computer logic board (CPU). The control voltage is 115 volts (60hz).

Operating Parameters

The programmed temperature will be displayed in Centigrade only.

The steam valve will be activated when the low water level has been reached and the actual water temperature is less than the programmed temperature.

While the steam valve is engaged, the cylinder will pause 3 minutes between each forward/reverse rotation. The cylinder will resume normal operation once the water bath temperature is within 5 degrees of the programmed temperature.

Cycle countdown time display will stop while valve is engaged.

During the cycle, if the water bath temperature drops 3 degrees below the programmed temperature, the steam valve will engage to maintain the water temperature.

The actual water temperature will display by pressing the Start and Down arrows simultaneously. The temperature light will be on whenever the temperature is being displayed. The temperature light will continue to be displayed until the Start button is pushed again, changing the display over to time remaining.

The control can be programmed to maintain any temperature between 20 degrees and 90 degrees. The programming is in 5 degree increments.

Any bath that has a programmed spin cycle will go through a short cool down bath before spinning if the actual bath temperature at the time of draining is above 65 degrees . This bath consists of filling tub to low level with WARM water while tumbling and then draining. This will continue until bath temperature is below 65 degrees.

If the Stop button is pressed momentarily (soak condition) while the heaters are energized, the cylinder will continue with a 3 minute pause between each forward/reverse rotation until the set temperature has been reached. The normal 15 minute pause between each forward/reverse rotation will then take place until the Start button is pushed to resume the cycle.

To assure that the programmed temperature will be maintained throughout the entire bath, the water temperatures will normally overshoot the set temperature by 1 to 3 degrees. The steam valve will engage if the bath temperature drops more than 3 degrees below the set temperature.

Programming Differences

The heated water bath is programmed in the water temperature selection portion of the microprocessor.

At temperature selection portion of programming there will be the following choices:

EE (tub empty), CC (cold), CH (warm), HH (hot), or any temperature between 20 degrees and 90 degrees in 5 degrees increments.

Use the Up arrow and Down arrow pad to set the water temperature desired (Centigrade) and then push the green Start button to accept the change and then move to the next programming sequence.

Continue with any other cycle changes as previously discussed.

To exit the program mode and accept all changes press the red Stop button while any one of the nine bath lights (top row of lights) are lit. The "Select Cycle" light should be on.

Turn the run/program key back to run position. If the program mode is exited incorrectly, the "Program" light will remain lit and the machine will remain in the program mode until the run/program key is turned back to the program position and the program is exited correctly.

Steam Calibration

The calibration should be checked whenever a temperature sensor has been replaced or if actual water temperature varies significantly from the display. To calibrate the temperature control board go to step # 15 of the diagnostic cycle (#31). Actual temperature will be shown in display.

On the temperature control board move the cal-run switch to the calibrate position. The factory set calibration temperature of 98 degrees C should show on the display after a few seconds. Now turn the adjusting screw clockwise to increase calibration point and display temperature or counterclockwise to decrease calibration point and display temperature. The display is updated every 5 seconds so make adjustments in very small increments.

Be sure to allow ample time for display to respond to updates. If adjustments of higher than 100 degrees C only the last two digits will be displayed.

Steam Valve Troubleshooting

If the valve does not engage in a heated bath:

- 1) Check the calibration switch is set to run position.
- 2) Check that I/O board jumpers are changed to the level side, Jumper must start closest to level input light and open pin will be towards door input lights.
- 3) Check actual water temperature is less than programmed temperature
- 4) Check the temperature sensor for open circuit or shorted
- 5) Check low level contacts on the pressure switch not closing
- 6) Check steam valve coil
- 7) Check the wiring between temperature board and sensor at all connectors and inspect wires for any damage.

If the temperature control board is removed, the programmed temperature values are retained in all baths and the water valves to fill that bath are chosen based on the programmed temperature.

Steam Heated Washer Schematics

Control voltage (115VAC / 60hz) is used to power the steam valve coil. The supply voltage will initiate from the I/O board Terminal number #6 (wht/blue wire) to the steam valve coil when heat is being called for by temperature board. The neutral will be supplied from the (blu/yel) wire connected to AC neutral terminal on the I/O board. The valve will get a signal when the pressure switch reaches low level. 115 Vac will operate steam valve until programmed temperature is reached.

Please remember you will lose a cold water dispenser flush signal as this is now the operating signal track on the I/O PCB board . It is marked on the lettering shield on the top of the I/O board.

WN0600SA-12XN

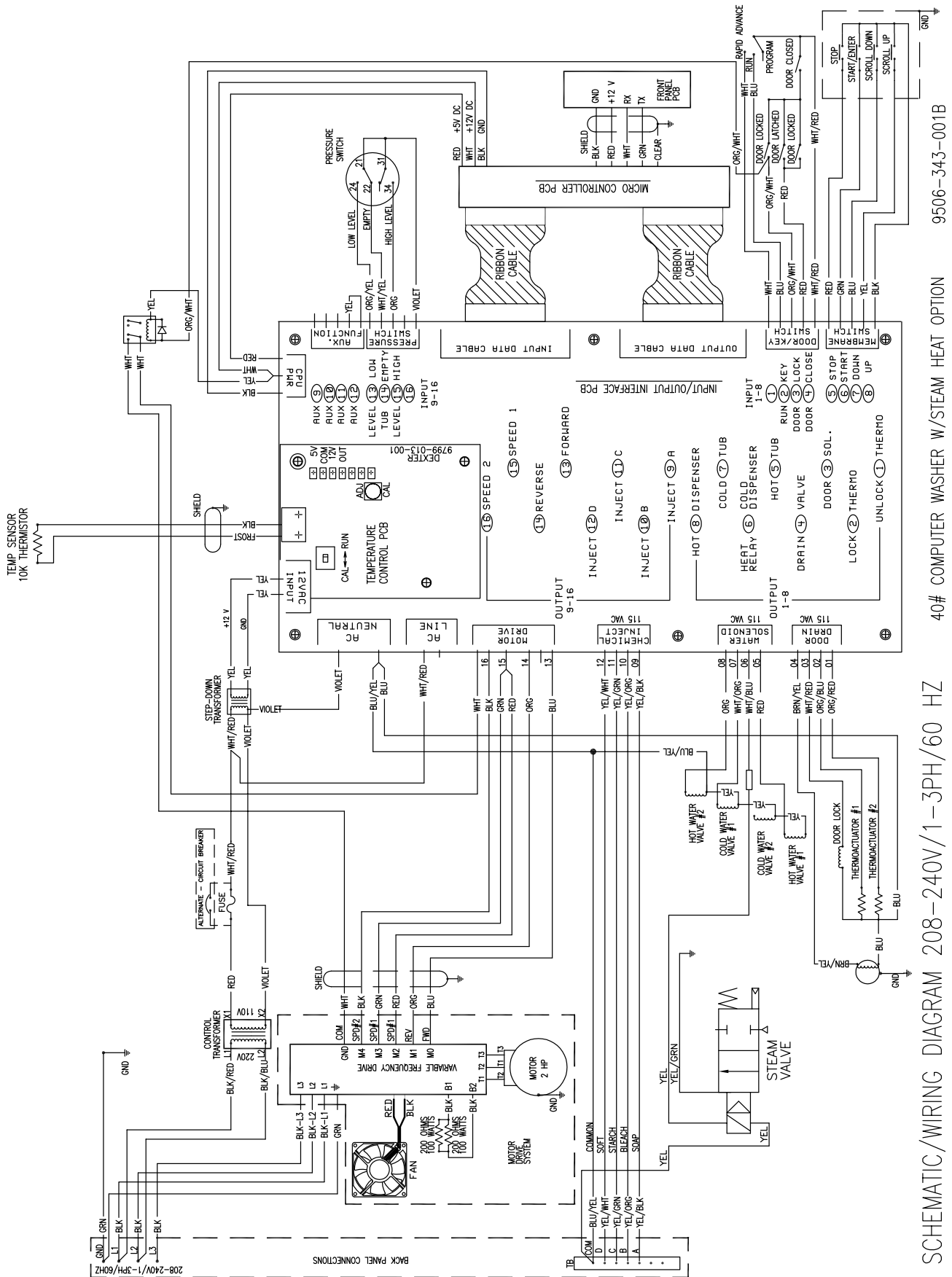

SCHEMATIC/WIRING DIAGRAM 208-240V/1-3PH/60 HZ

40# COMPUTER WASHER W/STEAM HEAT OPTION

9506-343-001B

WN0900SA-12XN

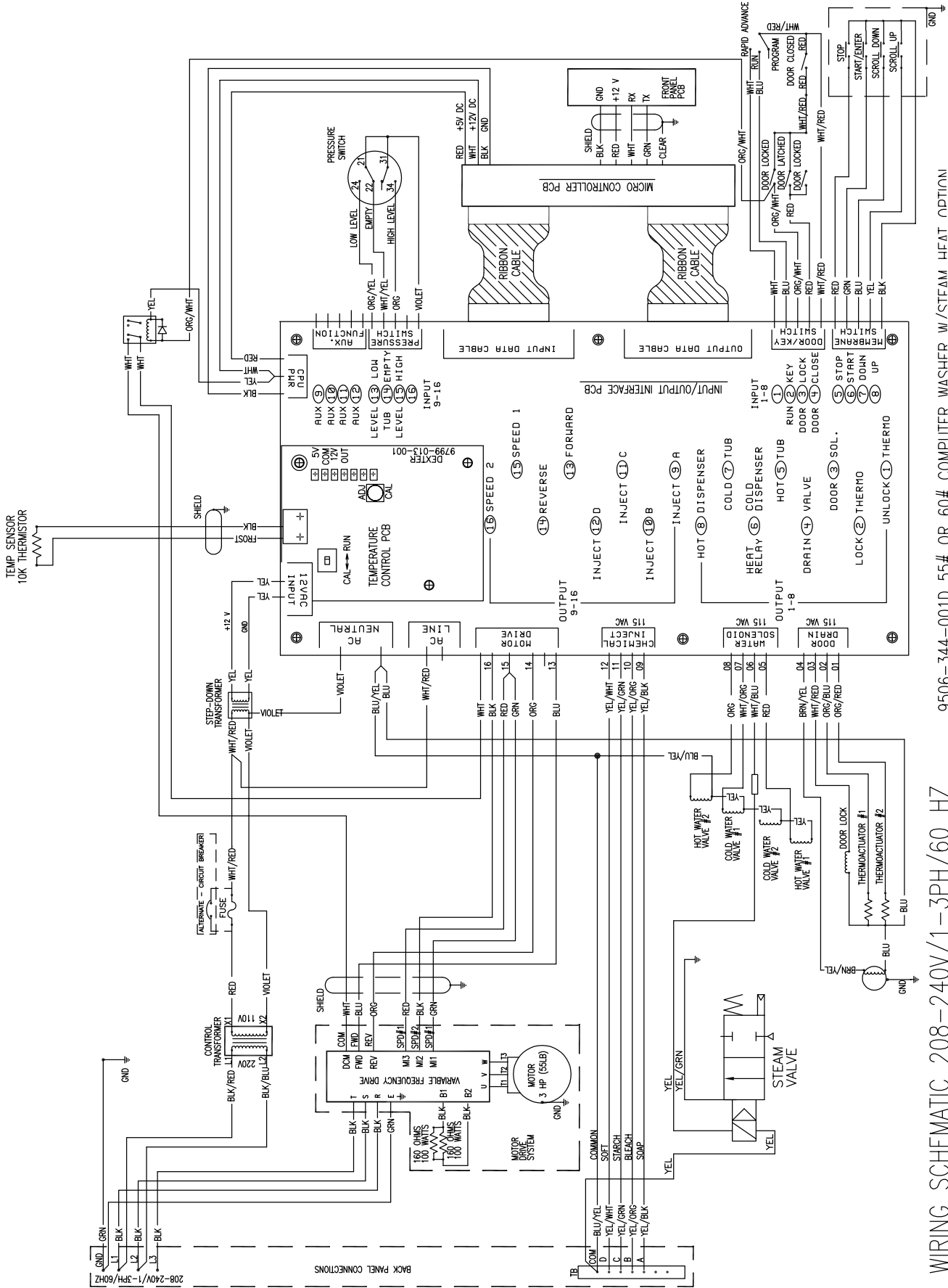

WIRING SCHEMATIC 208-240V/1-3PH/60 HZ 9.506-344-001D 5.5# OR 60# COMPIUTER WASHER W/STEAM HEAT OPTION

WN1200SA-12XN

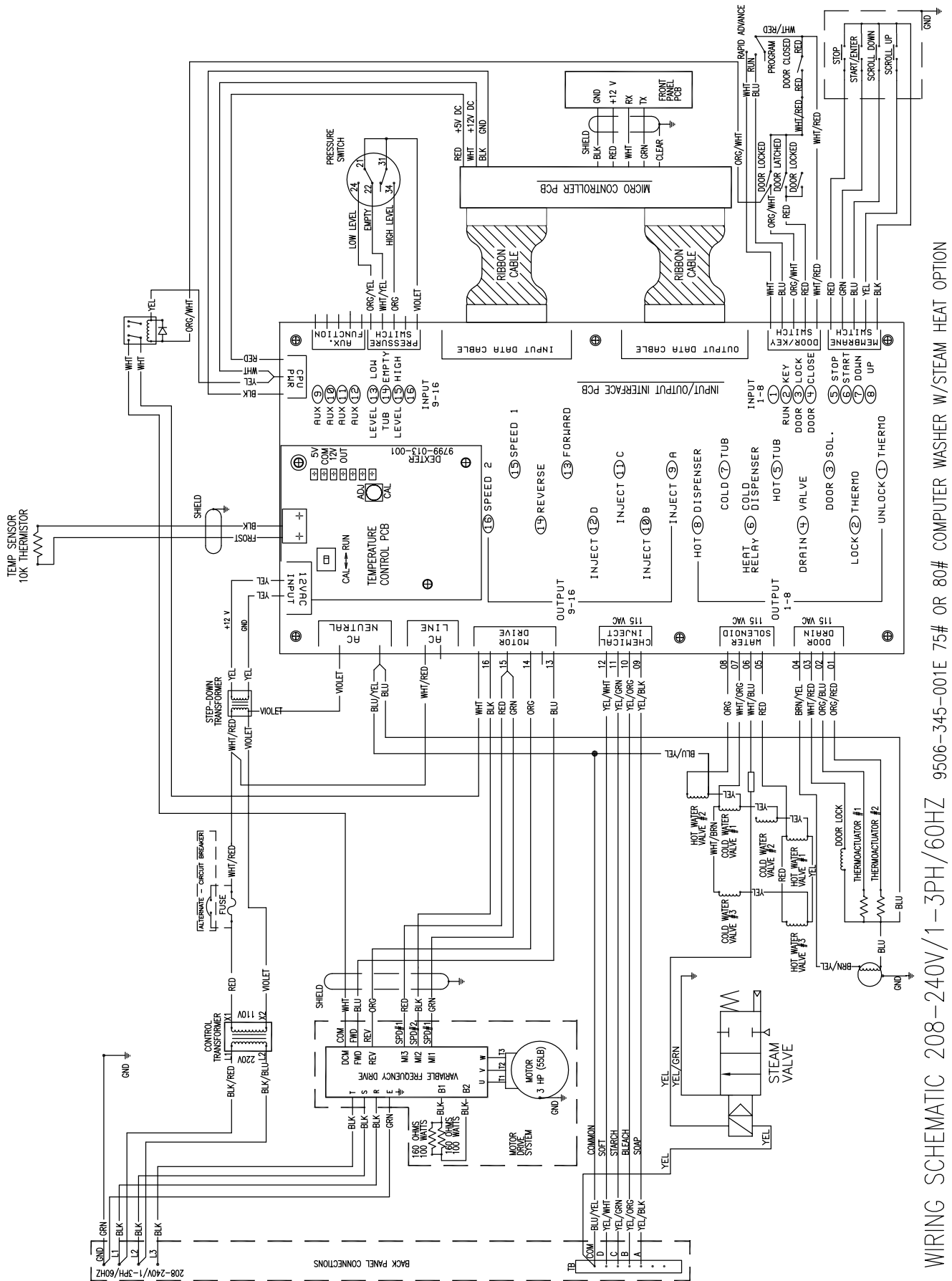

WIRING SCHEMATIC 208-240V/1-3PH/60HZ 9506-345-001E 75# OR 80# COMPUTER WASHER W/STEAM HEAT OPTION

Section 9:

50 Hz Models

Parts in this section used only in these models. All other parts are same as standard 60 Hz pages.

	Model	hz	Phase	Voltage	Heat Option	G's
9999-662-002	Wn0600xa-39xn2x-sskcs-vrx	50	1ph	230-240v		100
9999-662-004	Wn0600ea-68xn2x-sskcs-vrx	50	3ph	400v	Heated Electric	100
9999-662-005	Wn0600ea-59cn2x-sskcs-vrx	50	1ph	230v		100
9999-665-002	Wn0900xa-39xn2x-sskcs-vrx	50	1ph	230-240v		100
9999-665-006	Wn0900ea-58cn2x-sskcs-vrx	50	3ph	400v	Heated Electric	100
9999-665-004	Wn0900ea-68xn2x-sskcs-vrx	50	3ph	400v	Heated Electric	100
9999-669-002	Wn1200xa-39xn2x-sskcs-vrx	50	1ph	230-240v		100
9999-669-004	Wn1200ea-68xn2x-sskcs-vrx	50	3ph	400v	Heated Electric	100

Transformer, Electrical, & Filter and - 50 HZ models

Key	Component	T-600	T-900	T-1200	QTY
1	EMI Filter, 1Ph, 24 Amp	9183-045-001	9183-045-001	9183-045-001	1
*	Wire Assembly Black / Red	8220-061-003			1
*	Wire Assembly Black / Blue	8220-061-004			1
2	EMI Filter (Ferrite Core)	9183-033-001	9183-033-001	9183-033-001	2
3	EMI Line Filter (EP)	9133-032-004	9133-032-001	9133-032-001	1
	Filter Mounting Plate Assembly			9552-758-001	
*	Wire Assembly, RED	8220-065-024	8220-065-024	8220-065-030	1
*	Wire Assembly, BLU	8220-065-018	8220-065-018	8220-065-031	1
4	Transformer-Control	8711-008-001	8711-008-001	8711-008-001	1
*	Instructions, Transformer Connections	8507-230-003	8507-230-003	8507-230-003	1
*	Wire Assembly, RED	8220-065-011	8220-065-011	8220-065-030	1
5	Circuit Breaker	5198-211-002	5198-211-002	5198-211-002	1
*	Wire Assembly, VIO 8"	8220-065-013	8220-065-013	8220-065-013	1
*	Wire Assembly, YEL 8"	8220-065-012	8220-065-012	8220-065-012	1
6	PCB Assembly, I/O interface	9799-003-003	9799-003-003	9799-003-003	1
*	Wire Assembly, Jumper, YEL	8220-123-001			1
*	Bracket Drive Mounting	9985-178-001	9029-184-001		1
*	Owner's Booklet	8514-241-002	8514-244-002	8514-246-002	1

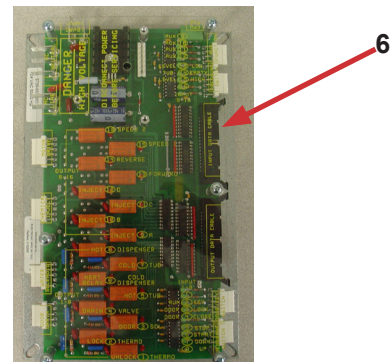
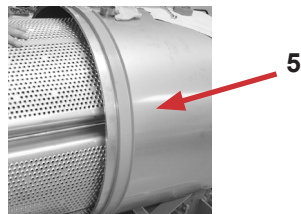
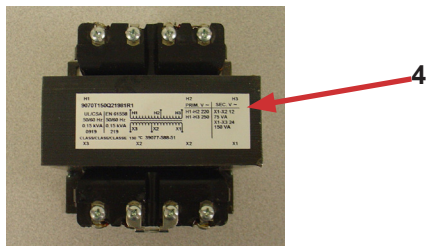
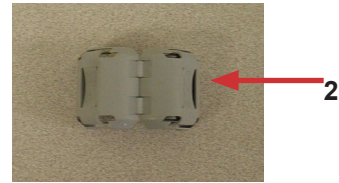
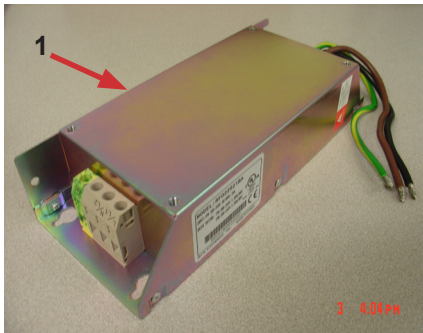

Water Valve, Drain Valve, 50hz models

	Description	T-600	T-900	T1200	QTY
1	Water Valve	9379-183-013	9379-183-013	9379-183-013	2
3	Drain Valve 3" inch	9379-202-002	9379-202-002	9379-202-002	1
4	Water Valve , Mueller single			9379-194-003	2
5	Solenoid 24VAC/50Hz	9536-082-001	9536-082-001	9536-082-001	1
6	Thermoacuator 24 VAC/50Hz	9586-001-003	9586-001-003	9586-001-003	2
*	Screw #10-32 TT X1/2	9545-008-027	9545-008-027	9545-008-027	3
*	Screw #8-32 X3/8	9545-010-006	9545-010-006	9545-010-006	2
*	Screw Hex 8B X1/4	9545-045-001	9545-045-001		4
*	Terminal Strip Marker, Inject	9558-028-002	9558-028-002	9558-028-002	1
*	Wiring Harness, Power Terminal Block	9627-865-002	9627-747-003	9627-747-002	1

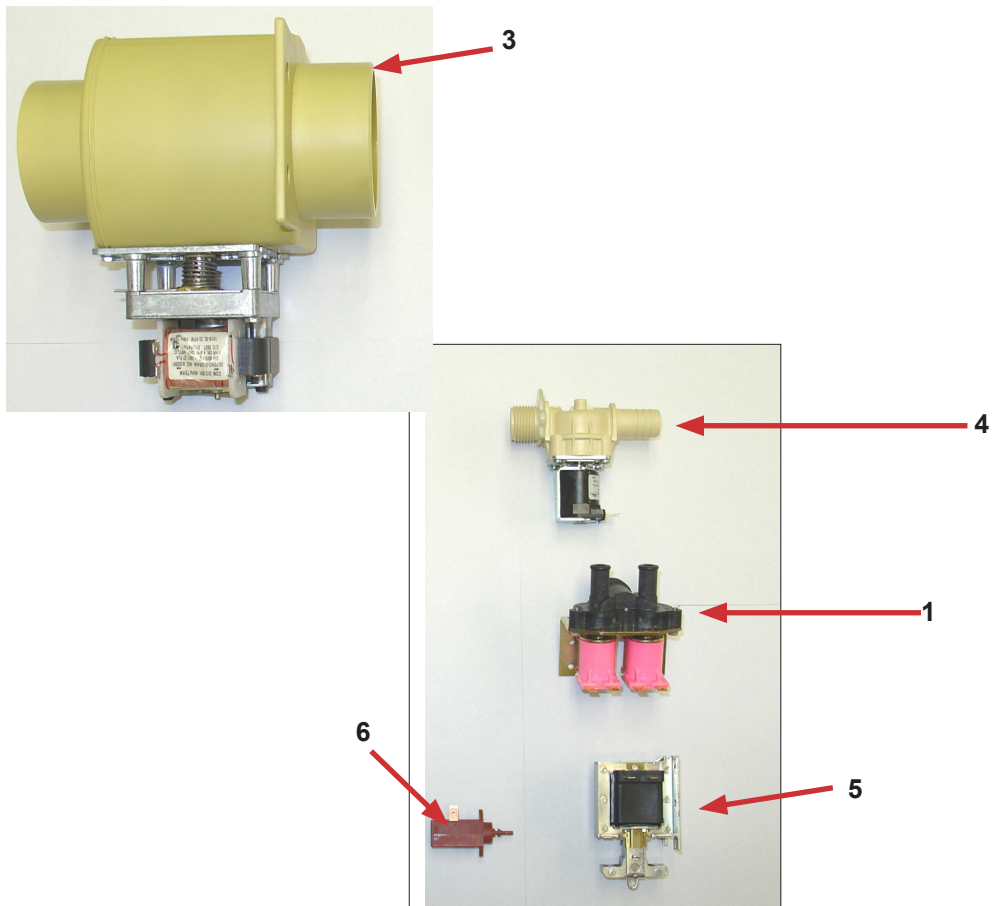

All Models 50 Hz Gear Motor Door Lock Assembly

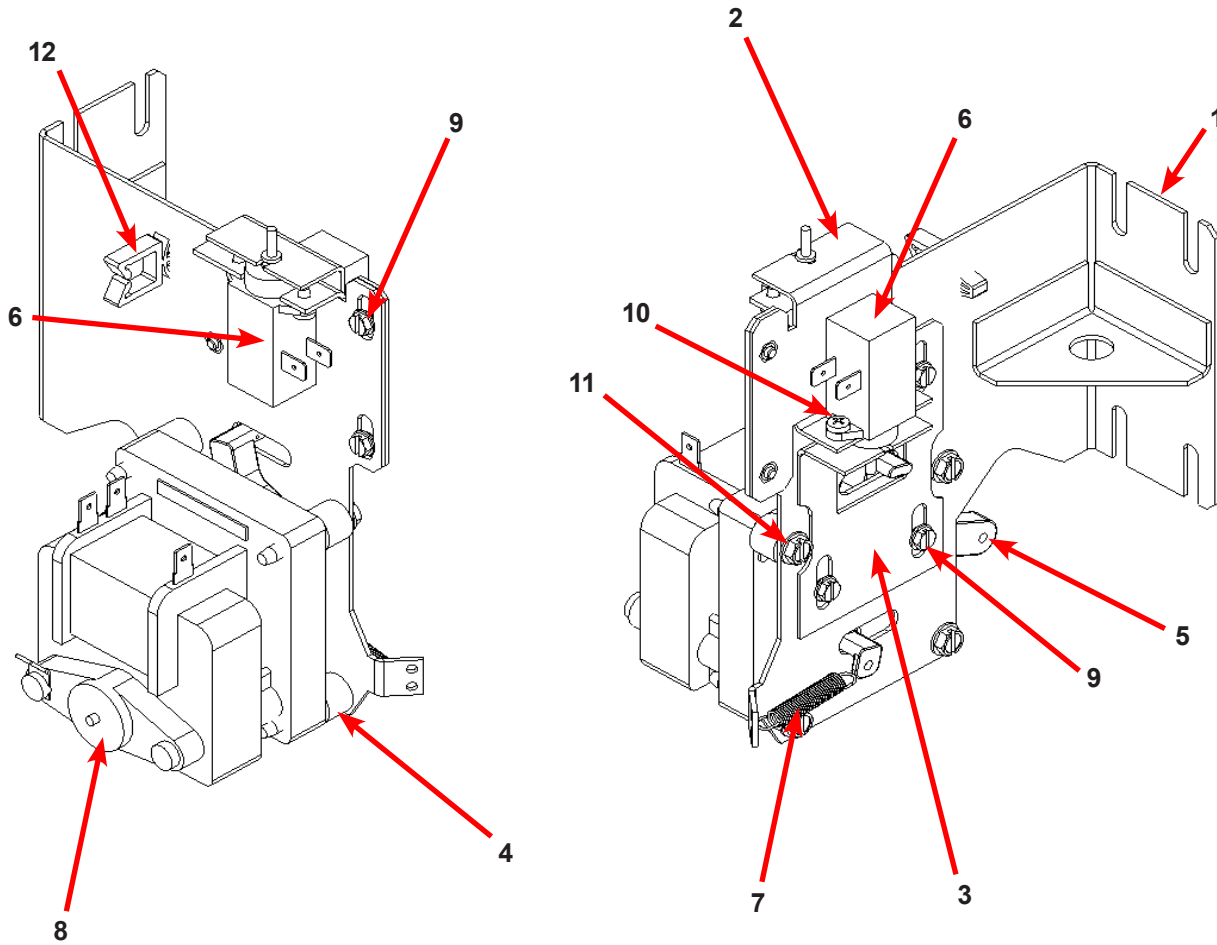

Key	Description	T650	T750	T950	T1450	QTY
*	Actuator Assembly (Includes 1-10, Rod NOT included)	9892-015-002	9892-015-002	9892-015-002	9892-015-002	1
1	Bracket Assy, Slide Lock Actuator	9985-190-001	9985-190-001	9985-190-001	9985-190-001	1
2	Bracket Assy, Slide - Unlock	9985-189-001	9985-189-001	9985-189-001	9985-189-001	1
3	Bracket Slide Lock	9029-204-001	9029-204-001	9029-204-001	9029-204-001	1
4	Spacer, Plastic	9538-157-021	9538-157-021	9538-157-021	9538-157-021	4
5	Arm - Door Lock	9001-063-001	9001-063-001	9001-063-001	9001-063-001	1
6	Thermoactuator - Door Lock Relay 24V	9586-001-003	9586-001-003	9586-001-003	9586-001-003	2
7	Spring - Extension	9534-350-001	9534-350-001	9534-350-001	9534-350-001	1
8	Motor & Gear Assembly 24V	9914-137-014	9914-137-014	9914-137-014	9914-137-014	1
9	Screw -Hxwshrhdslsems, 6-32 x 3/16	9545-044-003	9545-044-003	9545-044-003	9545-044-003	6
10	Cross Recessed PAn Hd Tapping screw	9545-031-011	9545-031-011	9545-031-011	9545-031-011	4
11	Screw Pnhcdr, 10-32 UNFx0 .75	9545-012-027	9545-012-027	9545-012-027	9545-012-027	4
12	Standoff-Wire Saddle	9527-007-001	9527-007-001	9527-007-001	9527-007-001	1
*	Rod, Door Lock	9497-225-	9497-225-013	9497-225-015	9497-225-016	1
*	Harness, Door Lock/Drain, P17	9627-796-001	9627-796-001	9627-796-001	9627-796-001	1
*	Rod, Door Lock		9497-225-010	9497-225-013	9497-225-015	1

Misc Parts -50 HZ. Models

KEY	Part Description	T-600	T-900	T-1200	Qty
*	Nuts #10-32UNF,2B			8640-413-002	7
1	Transformer, Control	8711-008-001	8711-008-001	8711-008-001	1
2	PCB Assembly, I/O interface	9799-003-003	9799-003-003	9799-003-003	1
*	Wiringlabel-Schematic	9506-760-001	9506-764-001	9506-772-001	1
*	Stripe Terminal Marker (injector)24v	9558-028-002	9558-028-002	9558-028-002	1
*	Terminal Lug Solderless	8652-134-002	8652-134-002	8652-134-002	1
*	Angle support ,Trough		9003-229-001	9003-308-001	1
*	Contol Trough only	9839-016-001	9839-016-001	9839-016-001	1
*	Complete Controlsassembly -Trough 50hz	9857-214-004	9857-216-007	9857-217-004	1
*	Label-Fusing & Installation	8502-619-004	8502-619-003	8502-619-003	1
*	Screw #6Tx5/16		9545-031-011	9545-031-011	2
*	Tub Assembly	9930-164-001	9930-158-002	9930-1503001	1
*	Tub & Cylinder Assembly	9869-033-001	9869-027-004	9869-022-003	1

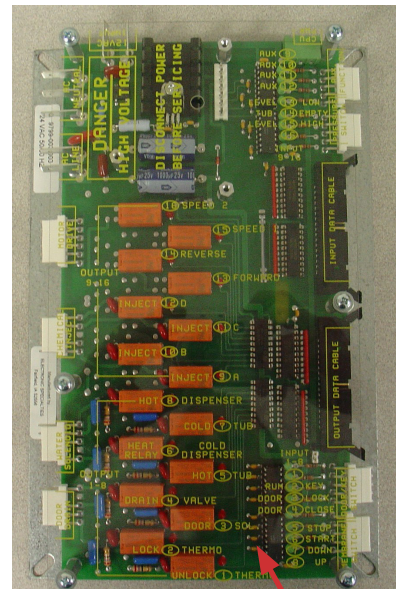
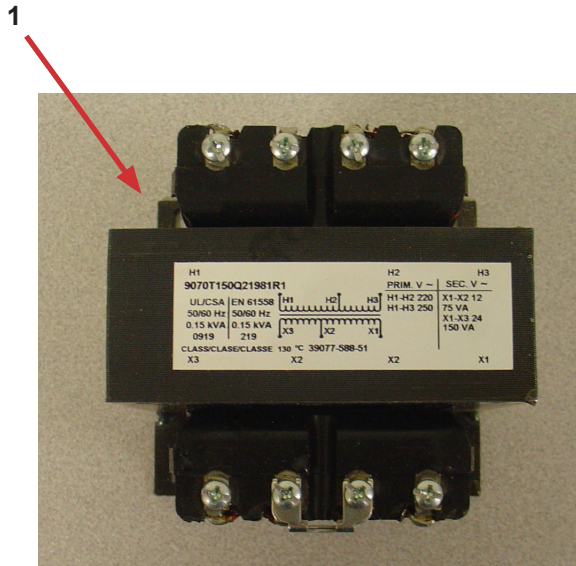

2

50HZ Electric Heated Models

KEY	Part Description	T600	T900	Qty
*	Relay	5192-285-003	5192-285-003	2
*	Relay Heater (40AMP) 24 vac	5192-290-001	5192-290-001	1
*	Circuit breaker	5198-211-002	5198-211-002	1
*	Pcb Assembly I/O interface	9799-003-003	9799-003-003	1
1	Pcb Assembly -Temp Control	9799-013-001	9799-013-001	1
*	Water Valve Dual	9379-183-007	9379-183-007	2
*	Transformer Control	8711-008-001	8711-008-001	1
*	Cover (Heater Terminals)	9074-286-002	9074-330-001	1
	Bracket (Shield Mounting)	9029-095-001	9029-095-001	2
*	Filter Line Washer (EP)	9183-032-001	9183-032-001	1
*	Filter -EMI	9183-033-001	9183-033-001	2
*	Filter EMI , 1 phase 24AMP	9183-045-001	9183-045-001	1
*	Drain Valve 3" 24 vac	9379-187-003	9379-187-003	1
*	Strip Terminal Marker injector 24v	9558-028-001	9558-028-001	1
*	Controlsassembly -Trough	9857-152-004	9857-179-001	1
2	Heater Assembly		9870-087-001	9
2	Heater Assembly	9870-087-001		6
*	Terminal Block Power	9897-033-002	9897-033-002	1
*	Terminal Lug solderless	8652-134-002	8652-134-002	1
*	Outer Tub Assembly	9930-139-001	9930-153-002	1
*	Tub & cylinder Assembly	9869-010-001	9869-024-002	1
3	Sensor Assembly	9501-005-002	9501-005-002	1
*	Owners Manual	8514-143-001	8514-190-001	1
*	Wiring Label Schematic	9506-306-001	9506-307-001	1
*	Label Warning Highvoltage	8502-614-004	8502-614-004	3
*	Label Fusing Installtion	8502-619-008	8502-619-006	1
*	Screw #10Bx1/2		9545-008-026	3
*	Screw 6Bx3/8	9545-031-003	9545-031-003	2
*	Screw 6ABx3/4	9545-031-010	9545-031-010	2
*	Screw #6TX5/16	9545-031-011	9545-031-011	2
*	Screw 6-32x1/4	9545-044-004	9545-044-004	3
*	VFD mounting Bracket	9029-095-001	9029-184-001	1
4	Drain Hose Tub to Valve	9242-456-002	9242-459-002	1

50HZ Electric Heated Models

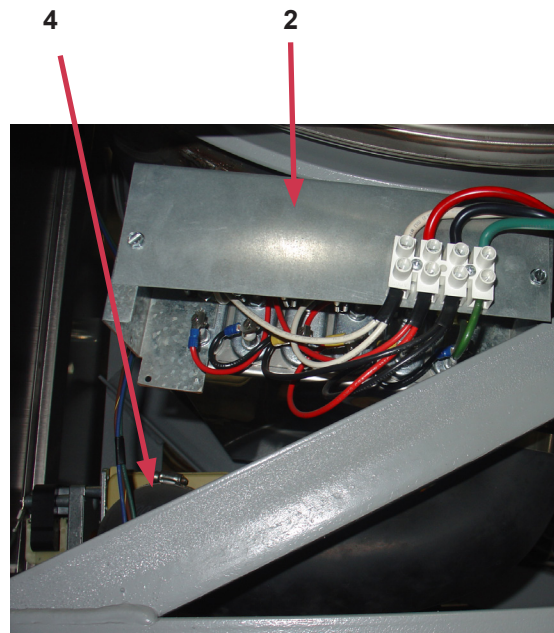
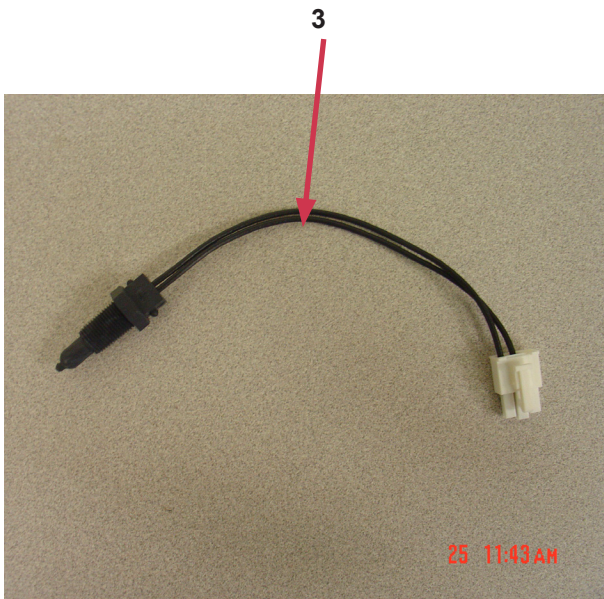
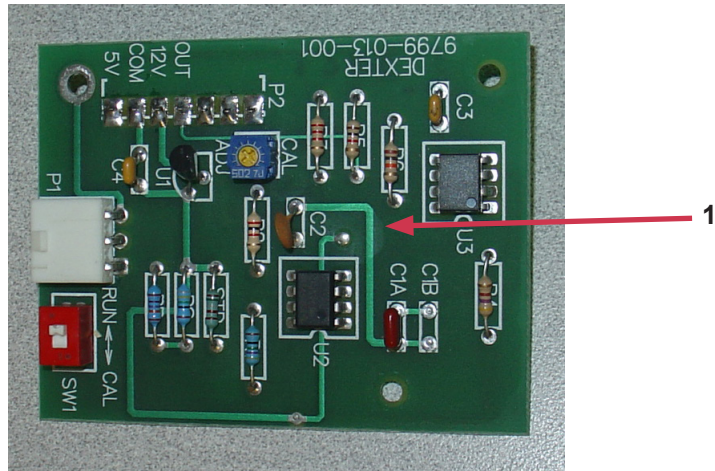

50HZ Electric Heated Electric Wires

KEY	Part Description	T600	T900	Qty
*	Wire -Diode	8220-001-442	8220-001-442	2
*	Wire Assy Grn 4"		8220-001-484	8
*	Wire Assy Gry 4"		8220-059-001	6
*	Wire Assy Grn 4"	8220-001-484		5
*	Wire Assy Gry 4"	8220-059-001		4
*	Wire Assy Wht ,8"	8220-059-002	8220-059-002	2
*	Wire Assy Red 8"	8220-059-003	8220-059-003	2
*	Wire Assy Blk 8"	8220-059-004	8220-059-004	2
*	Wire Assy Red 9"	8220-063-002	8220-063-002	1
*	Wire Assy wht/blu 28"	8220-063-003	8220-063-003	1
*	Wire Assy Blu/yel 12"	8220-064-001	8220-064-001	1
*	Wire assy Grn 11"	8220-064-055	8220-064-055	1
	Wire assy. Red 22"	8220-065-011	8220-065-011	1
*	Wire Assy Yel 8"	8220-065-012	8220-065-012	1
*	Wire assy Vio 8"	8220-065-013	8220-065-013	1
*	Wire Assy. Red 29"			2
*	Wire Assy. Blu 29"			1
*	Wire Assy. Red 15"	8220-065-024	8220-065-024	1
*	Wire Assy. Blu 17"	8220-065-018	8220-065-018	1
*	Wire Assy. Wht/Blu 10"	8220-078-006	8220-078-006	1
*	Wire Assy. Yel jumper	8220-083-001	8220-083-001	1
	Wire Assy. Wht 8"	8220-084-001	8220-084-001	1
	Wire Assy. Red 8"	8220-084-002	8220-084-002	1
	Wire Assy. Blk 8"	8220-084-003	8220-084-003	1
	Wiring Harness Heater Assembly Main	9627-755-002	9627-755-002	1
	Wiring Harness TempSensor	9627-762-001	9627-762-001	1
	Wiring Harness Pwr Terminal Block	9627-879-002	9627-879-002	1

WN0600EA-68XN

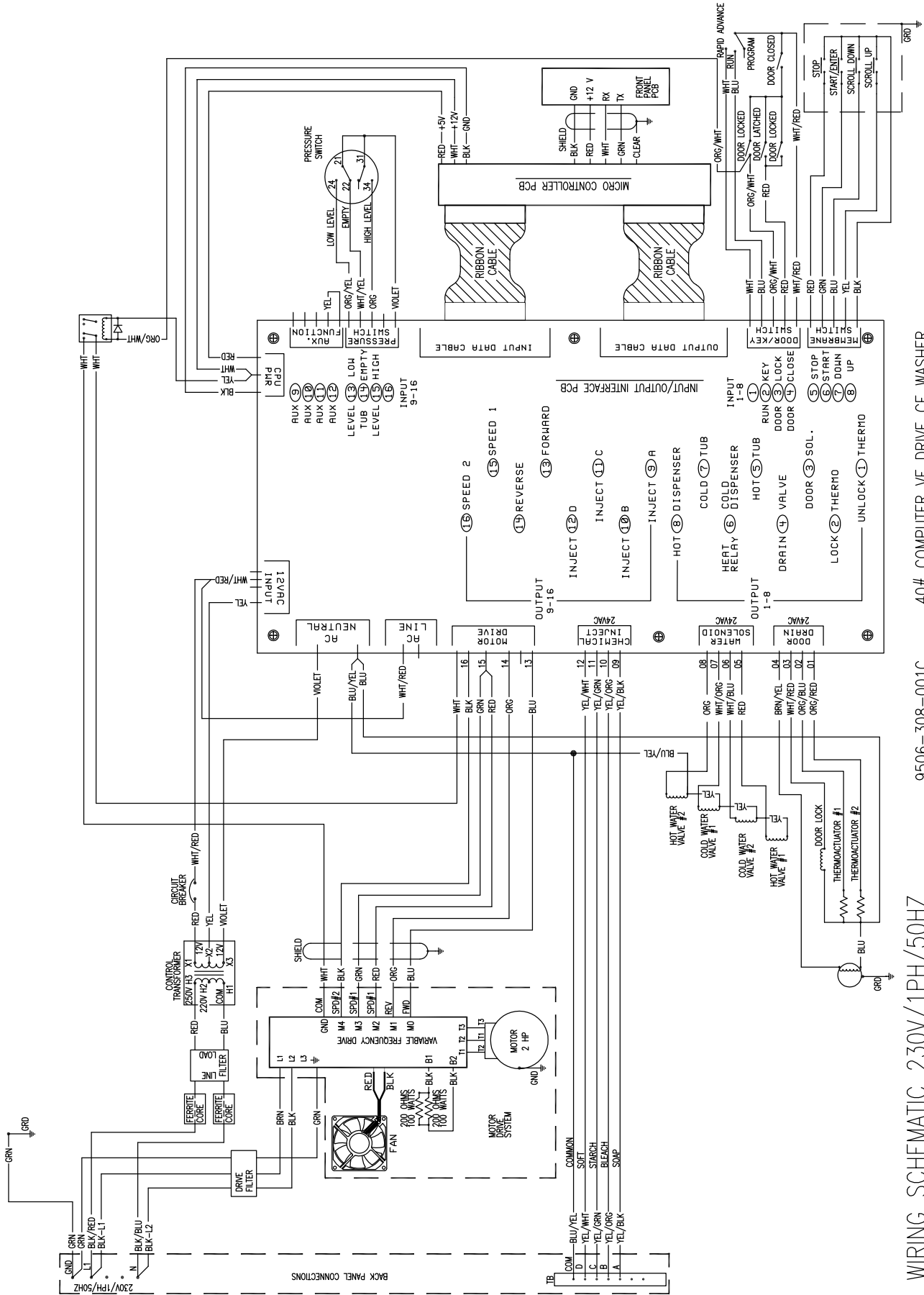

WIRING SCHEMATIC 230V/1PH/50HZ 9506-308-001C 40# COMPUTER VF DRIVE CE WASHER

WN0900EA-68XN

WIRING SCHEMATIC 380-415V/3PH, 50HZ

9345-912-001H

40# COMPUTER WASHER W/ HEAT OPTION

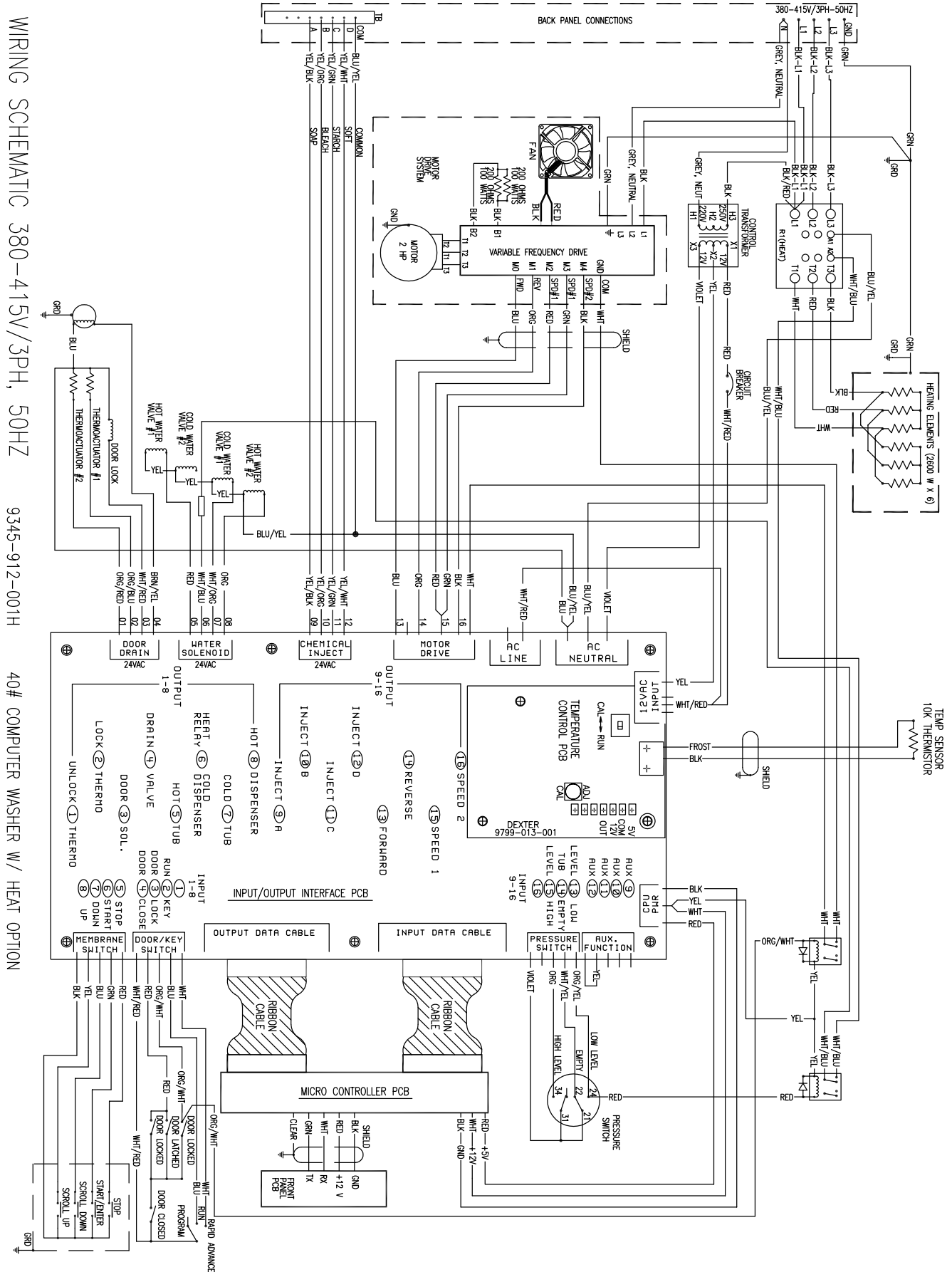

Section 10:

Maintenance

Preventative Maintenance

Daily

- Step 1:** Check that the loading door remains securely locked and cannot be opened during an entire cycle.
- Step 2:** Clean the top, front, and sides of the cabinet to remove residue.
- Step 3:** Clean the soap dispenser and lid and check that all dispenser mounting screws are in-place and tight.
- Step 4:** Check the loading door for leaks. Clean the door seal of all foreign matter.
- Step 5:** Leave the loading door open to aerate the washer when not in use.

Quarterly

- Step 1:** Make sure the washer is inoperative by switching off the main power supply.
- Step 2:** Check the V-belts for wear and proper tension.
- Step 3:** Clean lint and other foreign matter from around motor.
- Step 4:** Check all water connections for leaks.
- Step 5:** Check the drain valve for leaking and that it opens properly.
- Step 6:** Wipe and clean the inside of the washer and check that all electrical components are free of moisture and dust.
- Step 7:** Remove and clean water inlet hose filters. Replace if necessary.
- Step 8:** Check anchor bolts. Retighten if necessary.

