



DEXTER[®]
LAUNDRY

**USE THE BLUE TABS LOCATED ON THE
RIGHT AND LEFT SIDES OF THE FOLLOWING
DOCUMENT TO ADVANCE TO EACH SECTION.**

O-Cycle Accessories

WN1800XB-13EO2X 208-240 volts 60hz Single Phase or Three Phase

Key	Description	T-1800	QTY
*	Hose, Water Supply 3/8" I.D. x 48"	9990-027-011	2
*	Hose, Water Supply 5/8" I.D. x 48"	9990-027-013	2
*	Washer, Inlet Hose (furnished)	8641-242-000	2
*	Strainer, Inlet Hose (furnished)	9565-003-001	2
*	Bevel Washer for 5/8" bolt used in installations using angle iron bases	8641-586-002	
*	Bevel Washer for 3/4" bolt used in installations using angle iron bases	8641-586-003	4
*	Sealing compound	8538-151-001	1
*	TORX#20	8545-051-002	1
*	Special Tool For Removing Coin Acceptor Mounting Screws. (T-10 Torx)	8545-051-003	1
*	Flow Restrictors (in dispenser)	9475-002-003	2
*	Battery (used on Control PCB)	8612-001-001	1
*	Special Tool for adjusting spacing between outer tub front and cylinder front	8545-056-001	1
*	Clamps to hold tub front to outer tub when installing tub front	Vise Grip #11R	1
*	Coin Bearing & Seal Kit	9732-219-009	1
	Key Service Lock (6324)	6292-006-007	1
	USB, Thumb Drive (Blank)	9150-045-001	1
	USB, Thumb Drive, W/File	9150-045-002	1
*	Mode Light Backing Window	9635-022-001	1
*	MS300 Display	9150-058-001	1

Kits, Assemblies, & Common Parts

Loading Door & Door Lock Components	Part Number
Door Glass Gasket (Large Door)	9206-431-001
Door Handle Only (Large)	9244-091-001
Door Close Switch	9539-492-001
Door Lock Gear Motor Assembly	9892-015-003
Kit - Door Gasket Expander Kit (Small)	9732-139-001
Kit - Door Gasket Expander Kit (Large)	9732-139-002
Electrical Components	Part Number
Relay Board	9979-028-001
Main Control Board	9979-027-001
Kit-Replacement, Pressure Sensor (Only)	9732-315-001
VFD & Breaking Resistors Components	Part Number
Breaking Resistor 160 Ohms	9483-004-003
MS 300 VFD Display	9150-058-001
Data Cable (54")	9806-025-003
Drain & Water Valve Components	Part Number
Kit - 3" Drain Valve Seal Replacement	9732-327-001
Drain Valve 3"	9379-202-001
Water Valve (Dual)	9379-183-012
Water Valve (Single Mueller)	9379-194-001
Diaphragm (Dual)	9118-049-003
Diaphragm (Single Mueller)	9118-055-001
Cabinet Components	Part Number
Front Panel Screw	9545-008-014
Front Panel Finisher Washer	8641-585-001
Front Panel Spring Nut	8640-442-001
5/16 Hex Screw, Common	9545-008-026
Top Lock Key #6324	9306-025-001
Cylinder Plug (1.5" Plastic)	9456-041-007

Section 8:

Parts Data

6-Cycle On-Premise

Large Chassis

WN1800XB-12E02X

Wiring Harness Part # by Model

Key	Description	T-1800	
*	Cableassy-usb,snopin	9806-024-001	1
	Cableassy-data,rs485,40"	9806-023-005	1
*	Wiringharness-doorlock	9627-936-004	1
*	Wiringharn-pwrtermblk/VFD/ps	9627-932-001	1
*	Wiringharness-15pin,injection	9627-935-001	1
*	Wiringharness-15pin,non-inj	9627-934-001	1
*	Wireasy-blu,29"	8220-063-051	1
	Wireasy-blu/wht,29"	8220-063-052	1
*	Wireasy-jumper,blk	8220-117-002	2
	Wireasy-brn,#21,3"	8220-057-035	1
	Wireasy-wht,3"	8220-057-036	1
*	Wireasy-jumper,wht/red	8220-119-003	1
*	Wireasy-red/pnk,8"	8220-108-012	1
*	Wireasy-red/gry,8"	8220-108-013	1
*	Wiringharn-ctrl,graph,can,wshr	9627-922-002	1
*	Wiringharness-main,T-650-1450	9627-933-001	1
*	Wiringharness-chemical,v2.0wshr	9627-927-001	1
*	Wiringharness-drsw/VFD,stp	9627-928-003	1
*	Wiringharness-cntrl/relay,v2.0	9627-921-001	2
*	Wiringharness-ps,t-650-1450	9627-926-001	1
*	Wiringharness-pwrsup,v2.0wshr	9627-923-001	1
*	Wiringharness-thermist,v2.0wsh	9627-930-001	1
*	Wireasy,2.0	8220-158-029	1
*	Wireasy-jumper,v2.0,relaypcb	8220-159-005	1
*	Wireasy-jumper,v2.0,relaypcb	8220-159-006	1
*	Wireasy-org,71/2"	8220-062-052	1
*	Wireasy-wht/org,9"	8220-062-053	1
*	Wireasy-red,71/2"	8220-062-059	2
*	Wireasy-org,71/2"	8220-062-052	2

Cabinet and Front Panel Group Part # by Model

Key	Description	T-1800	QTY
1	Panel, Side (Left or Right) - stainless	9444-028-001	4
*	Strap Assembly (side panel)	9966-012-002	2
*	Shim (side panel)	9552-050-001	2
*	Nut, Hex 1/4-20 UNC (for strap assembly)	8641-414-006	8
2	Brace, Side Panel under front panel	9046-086-001	1
•	Nut, Hex	8640-414-006	2
*	Screw	9545-008-026	2
5	Panel Assy, Front Complete	99989-669-006	1
*	Band, Edge Protector	9578-092-005	1
6	Bumper Loading Door	9051-055-001	1
*	Nut, 1/4 x 20 for bumper	8640-414-003	1
*	Screw, Hex- To Control Panel	9545-008-026	2
*	Nut, Spring- To Control Panel 10/32	8640-442-001	2
7	Screw, Flat Head- Front to Sides	9545-008-014	4
8	Washer, Finish	8641-585-001	4
*	Nut, Spring-To Front Panel	8640-442-001	2
9	Label-Door Opening (Black)	8502-757-001	1
10	Label-Risk of Injury (Black)	8502-759-001	1
11	Panel, Control (Mounts Nameplate)	9989-530-001	1
*	Screw, Control Panel to Sides	9545-008-026	4
12	Nameplate Decal, Control	9412-278-001	1
14A	Panel Top Front	9444-029-001	1
14B	Panel Top Rear	9444-030-001	1
15	Lock, Top (w/Key)	8650-012-003	2
*	Key, Top- # 6324	6292-006-007	1
*	Cam, Lock-Top	9095-049-001	1
*	Nut, 9/32 - 28 Hex	8640-426-001	1
*	Washer Flat 5/16	8641-581-008	1
16	Door, Lower Service, Includes Handle	9960-286-005	1
17	Handle (bumper guard)	9244-086-004	1
*	Rivet Blind 3/16" Alum	9491-009-003	4
*	Screw	9545-008-023	4
18	Screw Mtg., Flat Head 10Bx1 3/4	9545-008-014	2
19	Washer, Finish	8641-585-001	2
*	Nut, Spring	8640-442-001	2

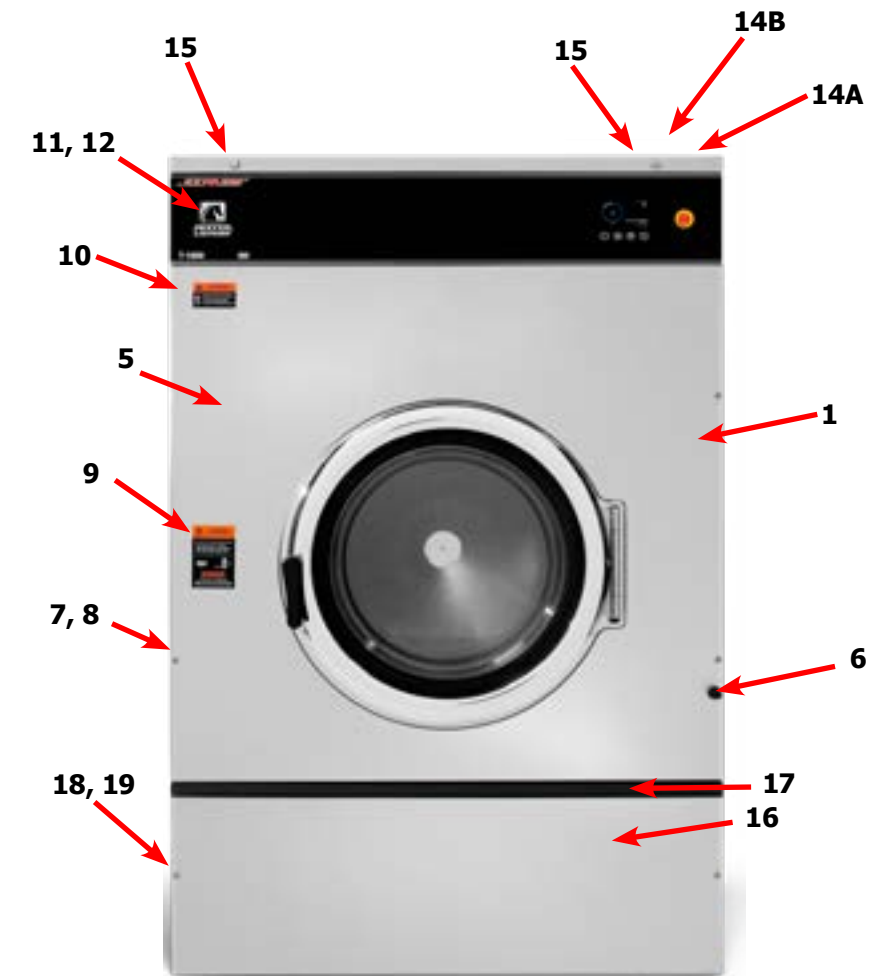
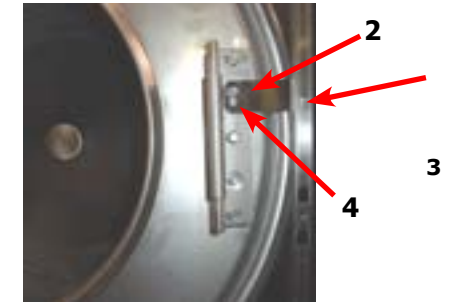

Rear View Access Part # by Model

Key	Description	T-1800	QTY
1	Drive Motor, 3 Phase	9376-328-001	1
2	Rod, Motor Mtg	9497-222-004	1
3	Motor-Bushing, Support	9053-074-002	2
4	Clamp for motor bushing	8654-117-019	2
5	Pulley, Motor	9453-175-002	1
5	Split TaperBushing (motor pulley)	9053-077-001	2
*	Screw taper bushing 1/4-20x1	9545-018-024	3
6	Bolt, Eye (1/4"-20x1/2")	9545-055-001	1
*	Nut, 1/4 Elastic Stop	8640-414-003	1
*	Link (open end)	9341-046-001	1
7	Chain (Spring Tension)	9099-012-004	1
8	Spring, Belt Tension	9534-369-001	1
9	Pulley, Driven	9453-176-006	1
10	Washer-Flat .675x2-1/2x1/4	8641-581-044	1
11	Lockwasher-Exttooth, 5/8	8641-582-020	1
12	Bolt, 3/4-11x1 1/2	9545-057-004	1
13	Bushing Taperlock (Pulley)	9053-078-002	1
14	Bolt, 3/8"-16 x 2"	9545-029-011	3
15	Washer, 3/8"	8641-582-003	3
16	Drive Belt	9040-079-006	1
17	Hose, Overflow to drain	9242-449-005	1
*	Clamp, Hose overflow to drain	8654-117-018	2
18	Hose, Overflow Vent Top	9242-463-006	1
*	Clamp, Hose Vent	8654-117-008	1
*	Vaccum Breaker ALL	9610-001-001	1
*	Clamp, Hose to Vacuum Breaker	8654-117-014	2
19	Hose, Vacuum Breaker to tub	9242-458-003	1
*	Vaccum Breaker Bracket	9029-266-001	1
20	Hose, Pressure Switch	9242-175-003	1
*	Clamp, Pressure Switch Hose	8654-117-015	1
21	Channel, Rear,	9947-055-005	1
22	Screw #10Bx1/2	9545-008-026	4
*	Nut, Spring	8640-442-001	4
23	Cover, Terminal Block	9074-267-001	1
*	Screw #10Bx1/2	9545-008-026	1
24	Bracket-switch,prox	9029-309-001	1
*	Washer-flat	8641-581-040	1
*	Screw-hxcap,5/8-11x3/4	9545-060-005	1
25	Switch-prox,18mm,shld,60"	9539-498-001	1
26	Sensorassembly-thermistor,10k	9501-005-002	1
*	Sealer-pipe	8538-132-000	1

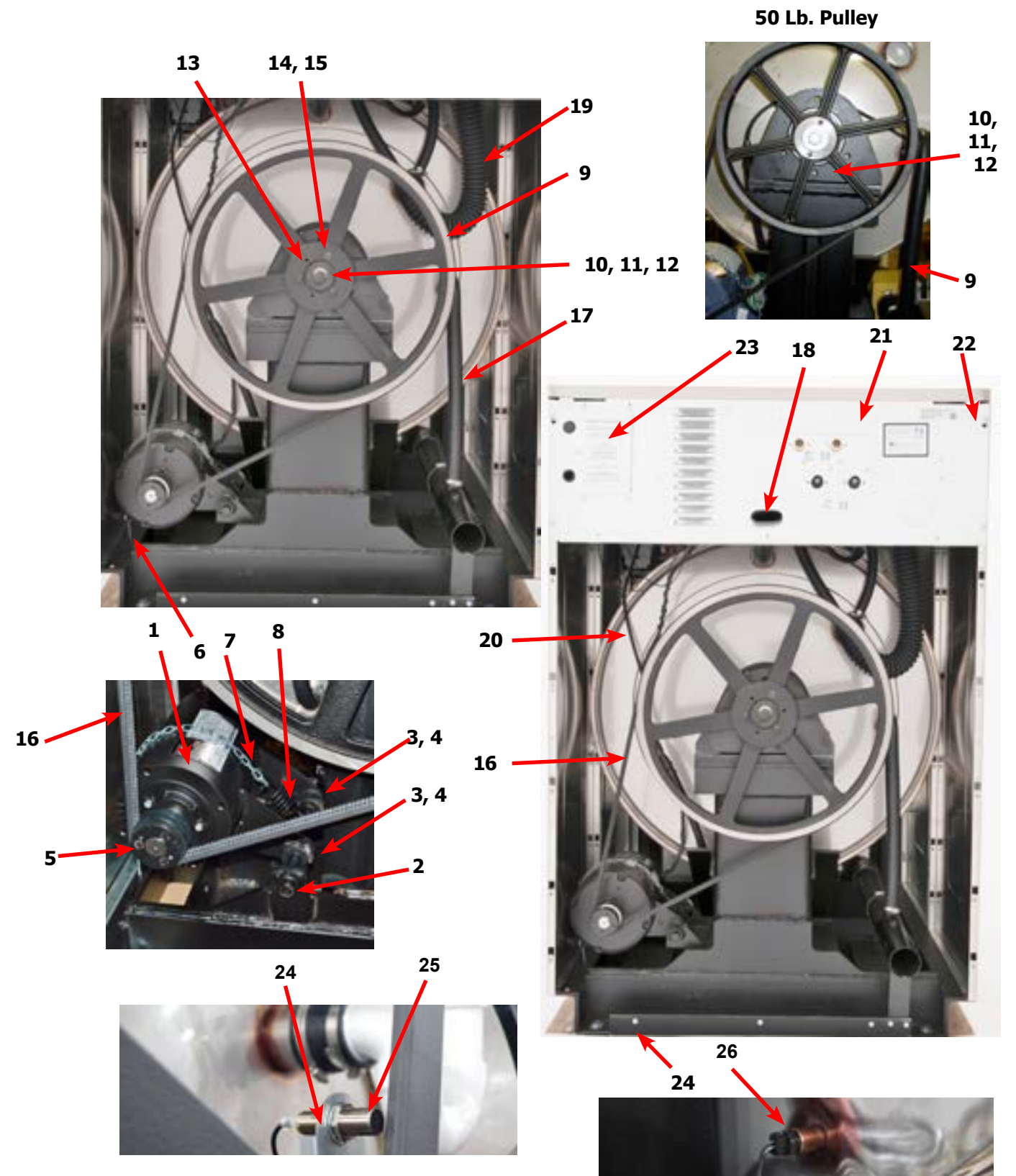

Key	Description	T-1800	QTY
*	Panel Assy., Back, Upper	9454-873-001	1
*	Panel Assy., Back, Lower	9989-872-001	1
*	Screw Panel Mtg.#10Bx1/2"	9545-008-026	13
*	Nut, Spring	8640-442-001	AR
28	Screw, To Base-1/4" x 3/4"	9545-030-002	3

Cylinder, Seals & Bearings Part # by Model

Key	Description	T-1800	QTY
*	Bearings and Seal Kit	9732-219-009	1
*	Housing, Bearing- Assembly (items #2-#6)	9803-209-001	1
2	Housing, Bearing	9241-195-003	1
3	Bearing, Front (Small)	9036-162-002	1
4	Bearing, Rear (Large)	9036-162-001	1
5	Spacer, Bearing	9538-185-001	1
6	Ring, Bearing Retainer	9487-238-004	1
8	Seal, Small V95A	9532-140-012	1
9	Seal, Large V140A	9532-140-008	1
10	Ring, Seal Mounting	9950-062-001	1
11	Tub Back Mating Ring	9487-261-005	1
11G	Mating Ring Guard Shield	9487-276-001	1
12	Bolt, Tub End of Bearing Housing (7/16-14x1), Bolt from inside Tub	9545-059-004	6
13	Washer, Flat	8641-581-034	6
14	Screw-Hex Cap, 7/8"-9 x 3 1/2" (Bearing Housing to Frame)	9545-066-001	6
15	Washers Spherical 7/8" (Male half) (Bearing Housing to Frame)	8641-588-003	6
16	Washers Spherical 7/8" (Female half) (Bearing Housing to Frame)	8641-588-004	6
17	Nut 7/8"-9 (Bearing Housing to Frame)	8640-437-001	6
18	Pulley, Driven	9453-176-006	1
19	Bolt, 3/8"-16 x 2"	9545-029-011	3
20	Washer, 3/8"	8641-582-003	3
21	Bushing Taperlock (Driven & Large)	9053-078-002	1
22	Washer-Flat .675x2-1/2x1/4	8641-581-044	1
23	Lockwasher-Exttooth, 3/4	8641-582-020	1
24	Bolt, 3/4-10x1 1/2	9545-057-004	1
25	Tub & Cylinder Assy	9869-046-001	1
*	Cylinder Assy	9848-170-001	1
*	Tub Front	9974-012-001	1
*	Gasket, Tub Front	9206-421-003	1
*	Ring Assy, Tub Mtg-Front Clamp	9950-061-001	1
*	Bolt, Top Front Ring 3/8"-16 x 3"	9545-029-009	1
*	Nut C Series 3/8"-16	8640-415-001	1

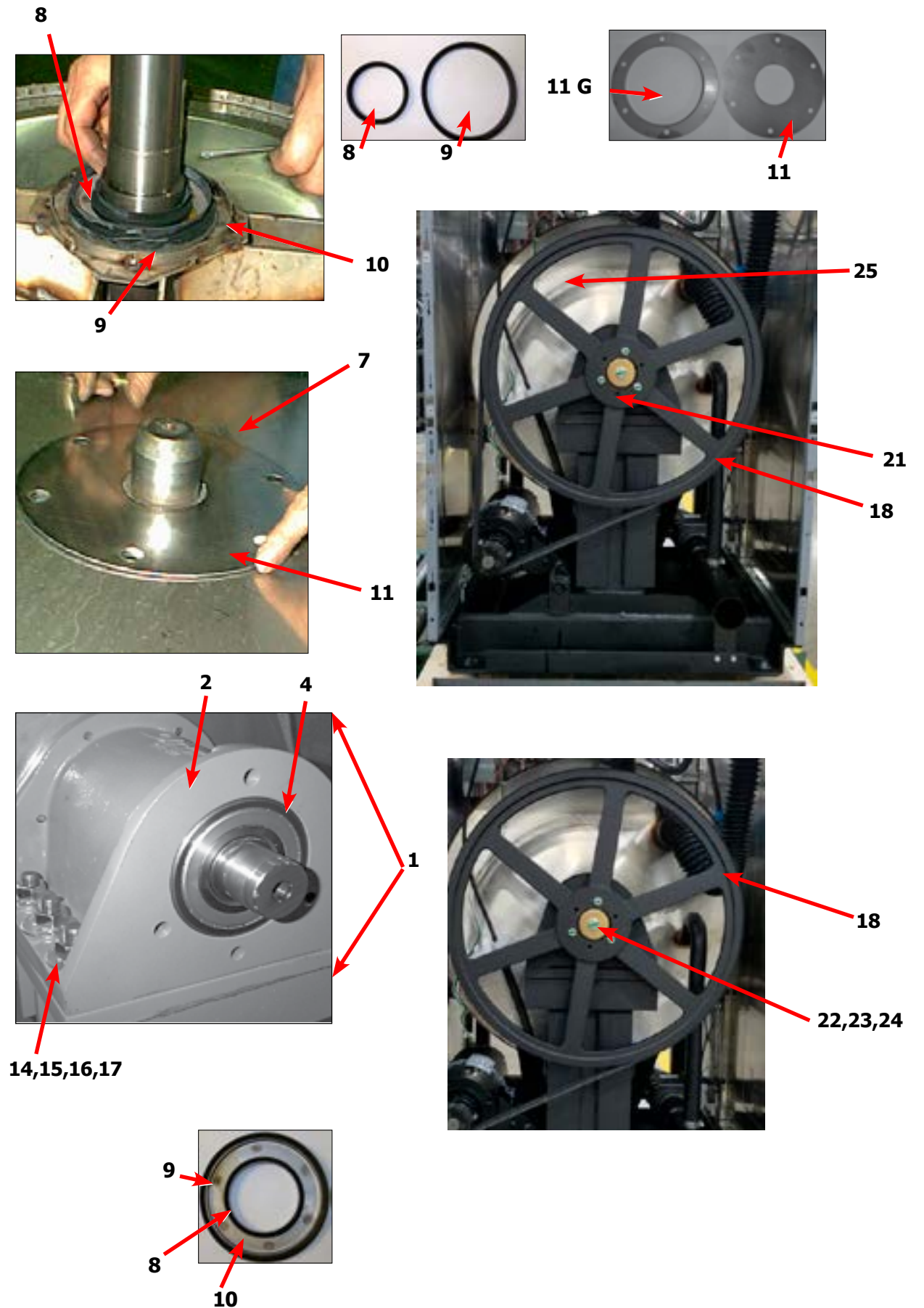

Door Latching Assembly (All Models)

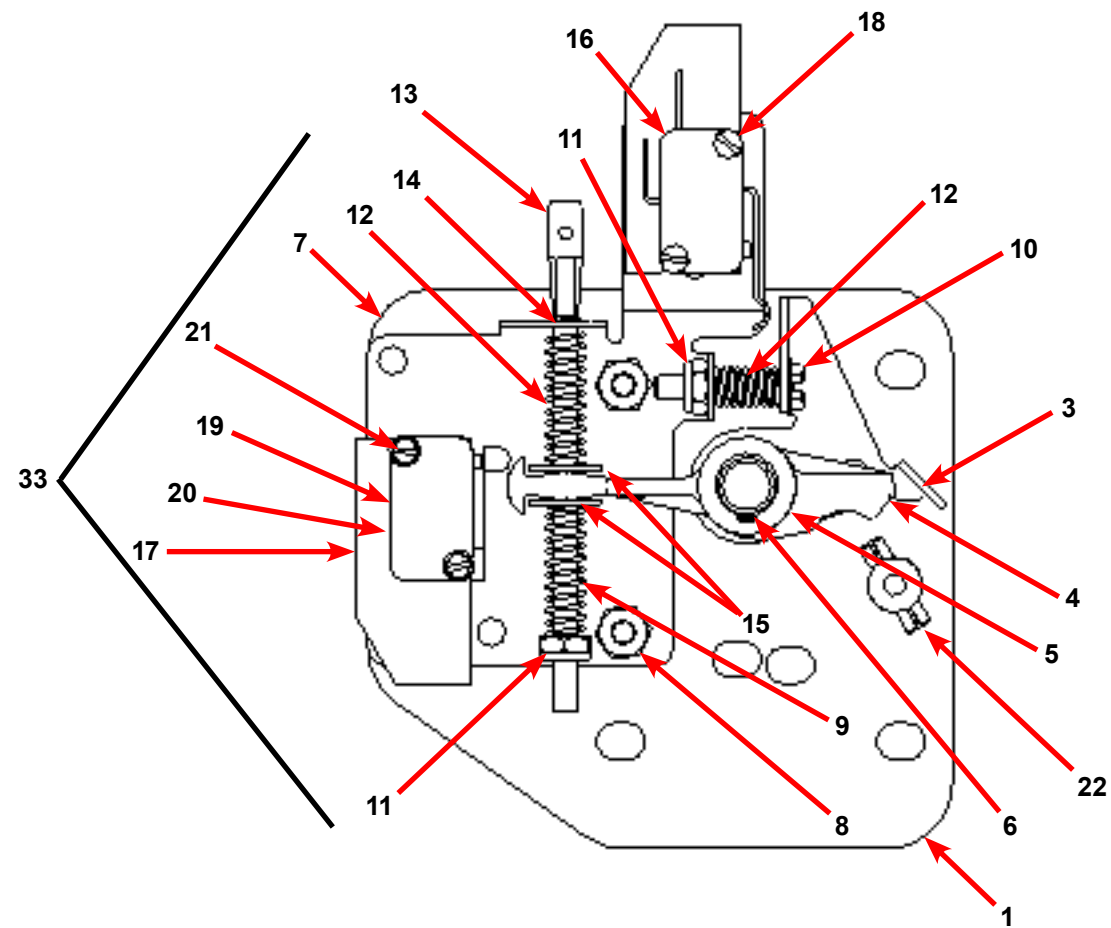

Key	Description	All Models	QTY
33	Latching Assy, Complete (includes #1 thru #22)	9885-031-001	1
1	Plate Assy, Door Lock	9982-346-001	1
2	Washer, Flat (SS or Brass)	8641-581-030	1
3	Actuator, Latching Switch	9008-005-001	1
4	Pawl, Locking	9732-346-002	1
5	Washer, Spring	8641-569-003	1
6	Ring, Retaining	9487-200-004	1
7	Bracket Switch	9029-163-001	1
8	Nut, Hex 10-32 UNF	8640-413-002	2
9	Spring, Actuating	9534-364-002	1
10	Screw, Hx. 10-32 x 1"	9545-012-020	1
11	Nut, Elastic Stop 10-32	8640-413-004	2
12	Spring, Return	9534-364-001	2
13	Pin, Guide	9451-193-001	1

Key	Description	All Models	QTY
14	Ring, Retaining	9487-200-005	1
15	Washer	8641-581-031	1
16	Switch, Latching Sensing	9539-461-008	1
17	Shield, Switch	9550-169-003	3
18	Screw 4-40 x 5/8"	9545-020-001	2
18	Nut, Twin 4-40	8640-401-001	1
19	Switch, Locking Sensing	9539-461-007	2
20	Actuator, Switch Locking	9008-006-003	1
21	Screw 4-40 x 1 1/8"	9545-020-003	2
21	Nut, Twin 4-40	8640-401-001	1
*	Spacer Sensor	9538-182-001	*
22	Pin, Dowel (for door cam)	9451-193-001	1
*	Shim, Door Lock, Thin	9552-037-001	AR
*	Screw, Lock mtg 1/4"-20 x 3/4"	9545-018-014	3
*	Lockwasher 1/4" Ext tooth	8641-582-007	3
*	Door Pin Stud, 3/16" x 3/4"	9451-181-004	1

Gear Motor Door Lock Assembly

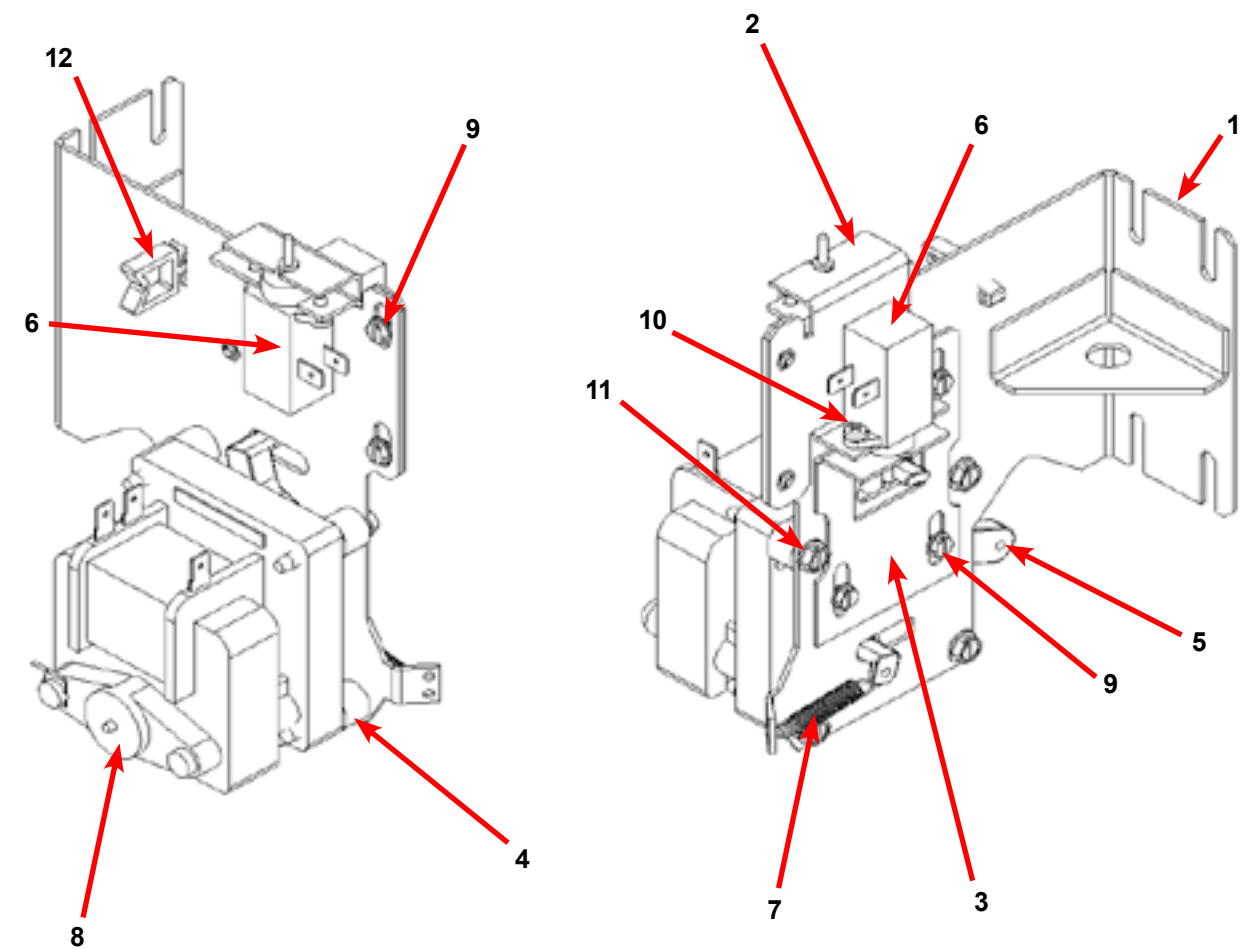

Key	Description	T-1800	QTY
*	Actuator Assembly (Includes 1-10, Rod NOT included)	9892-015-003	1
11	Screw - hxwshdsl, 10-24, 1.25f, ctd	9545-046-007	4
10	Cross Recessed Pan Hd Tapping screw	9545-031-011	4
9	Screw -Hxwshrdslsems, 6-32 x 3/16	9545-044-003	6
8	Motor & Gear Assembly 120v	9914-137-015	1
7	Spring - Extension	9534-350-001	1
6	Thermoactuator - Door Lock Relay 24v	9586-001-003	2
5	Arm - Door Lock	9001-063-001	1
4	Spacer, Plastic	9538-157-021	4
3	Bracket Slide Lock	9029-204-001	1
2	Bracket Assy, Slide - Unlock	9985-189-001	1
1	Bracket Assy, Slide - Unlock	9985-190-001	1
*	Rod, Door Lock	9497-225-016	1

Large Door & Hinge Group

Key	Description	T-1800	QTY
1	Door Hinge Assembly (mounts to tub front)	9955-031-001	1
*	Door Assembly Complete	9960-310-001	1
2	Door Ring 180 degree large hnge	9487-275-001	1
3	Door Gasket	9206-431-001	1
4	Door Glass Window	9635-020-001	1
*	Red Wire (Door Close Switch)	8220-063-036	1
*	Black Wire (Door Close Switch)	8220-063-037	1
5	Switch, Door Hinge Close (Plunger)	9539-492-001	1
6	Top Door Hinge Leaf	9845-006-001	1
7	Bottom Door Hinge Leaf	9845-007-001	1
8	Thrd Form Screw, Door Mtg 5/16" x 5/8"	9545-056-002	4
9	Screw, Loading Door Hinge Mtg (5/16" x9/16" ss)	9545-014-009	3
9	Washer, Star 5/16	9913-134-003	3
10	Bracket Retainer support side panel	9046-085-001	1
*	Shim Large door	9552-043-001	1

Key	Description	T-1800	QTY
*	Shaft Assembly-Loading Door (11-14)	9913-136-001	1
11	Shaft, Door Locking	9537-195-002	1
12	Cam, Locking	9095-051-001	1
13	Pin, Groove (1 1/4)	9451-181-005	1
14	Pin, Groove (3/4)	9451-181-004	1
15	Spring, Lock Cam	9534-360-002	1
16	Handle, Door	9244-091-001	1
17	Pin, Door Handle (groove)	9451-181-005	1
18	Trim, Edge	9578-092-002	1

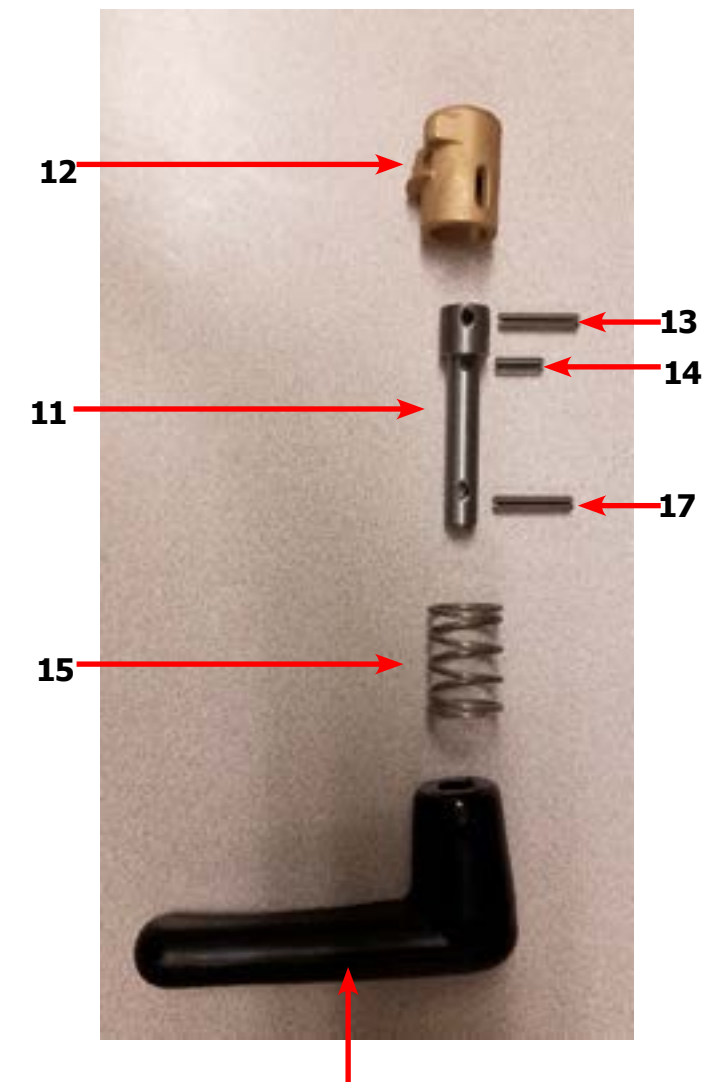
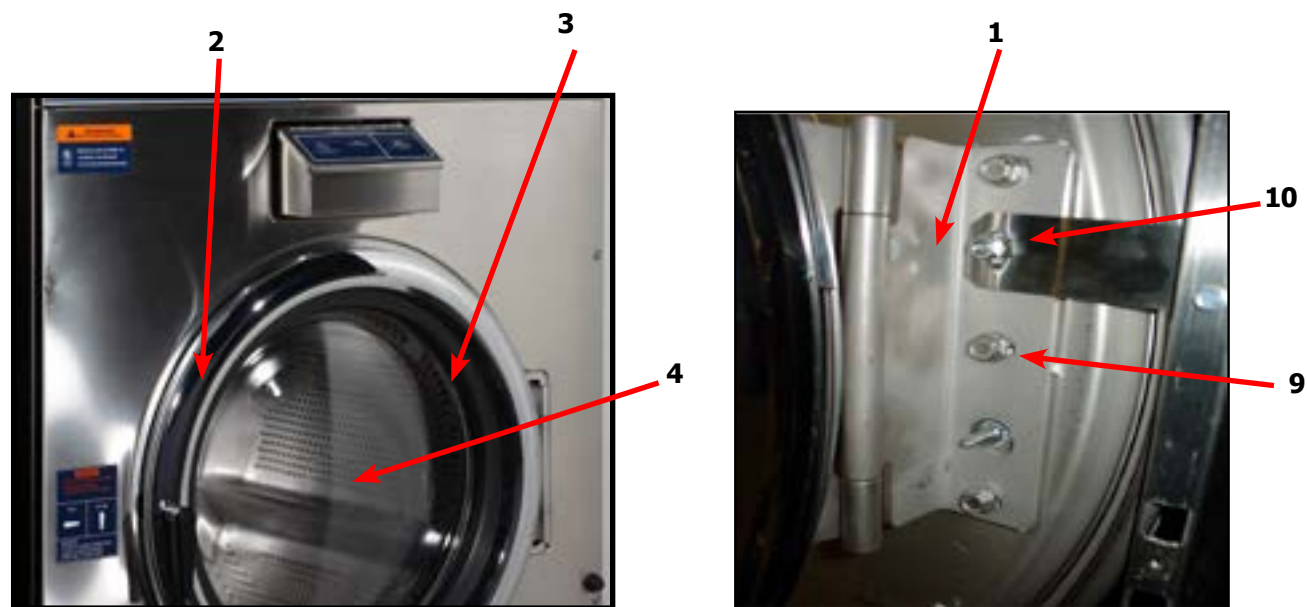

Water Inlet & Rear Channel

Key	Description	T-1800	QTY
1	Channel Panel, Rear	9497-029-001	1
*	Screw, #10B x 1/2	9545-008-026	4
*	Clip, Spring	8640-442-001	4
2	Mounting Plate Water Valves	9452-814-001	1
3	Nut-Elastic stop, #10-32	8640-413-002	2
4	Valve, Water Inlet (dual outlet) (see Water Inlet Valve Breakdown for individual parts)	9379-183-012	2
5	Screw, Valve Mtg	9545-008-026	4
8	Valve, Water Inlet (Single outlet) (see Water Inlet Valve Breakdown for individual parts)	9379-194-001	2
*	Screw, M4x0 7 x 8mm	9545-064-001	4
*	Wire-Assy, Jumper, Yellow	8220-119-002	1
9	Shield over Water Valves Plastic	9550-195-001	1
10	Push Clip	9083-121-001	3
11	Vacuum Breaker	9610-001-001	1
12	Vacuum Breaker Cap (Red)	0935-135-002	3
*	Bracket, Vacuum Breaker	9029-266-001	1
13	Screw, #10B x 1/2	9545-008-026	4
*	Clamp, Hose to Vacuum Breaker	8654-117-014	1
*	Hose, Vacuum Breaker to Tub	9242-458-003	1
*	Clamp, Tub End	8654-117-009	1
*	Hose, overflow Suds	9242-463-006	4
*	Clamp, Hose-Spring (overflow to tub back)	8654-117-018	2
14	Plate Assembly, Drive Mounting	9452-858-001	1
15	Nut-#10-32UNF, 2B	8640-413-002	4
16	VFD Delta drive 208-240 volt	9375-039-006	1
*	VFD Cooling Fan	9189-016-001	1
*	Wire assy Brown, 3"	8220-057-035	1
*	Wire assy Red, 3"	8220-057-036	1
*	Key Pad-Display Delta Drive	9150-058-001	1
*	Cable-Data, Communication (54")	9806-025-003	1
17	Bushing, 7/8	9053-067-002	1
18	Plug, 7/8	9545-041-006	1
19	Bracket, Terminal-Mounting	9029-326-001	1
20	Screw, #10B x 1/2	9545-008-026	4
21	Label-Warning	8502-639-001	1
22	Strip-Terminal Marker	9558-025-001	1
23	Terminal Block	9897-033-002	1
24	Screw-Phillips, 6ABx3/4	9545-031-010	2
25	Harness-Power, Terminal Block	9627-747-005	1
26	Bushing, 1"	9053-067-004	1
27	Terminal Lug, Solderless	8652-134-001	1
28	Lock-Washer Extooth #10	8641-582-006	1
29	Screw, #10-32 TTX 1/2 GRN	9545-008-027	1
*	Terminal Block Assembly, Injector, 7pos	9897-032-003	1
*	Terminal Strip, inject, 120v	9558-036-001	1
*	Screw, 4bx5/8	9545-053-002	2

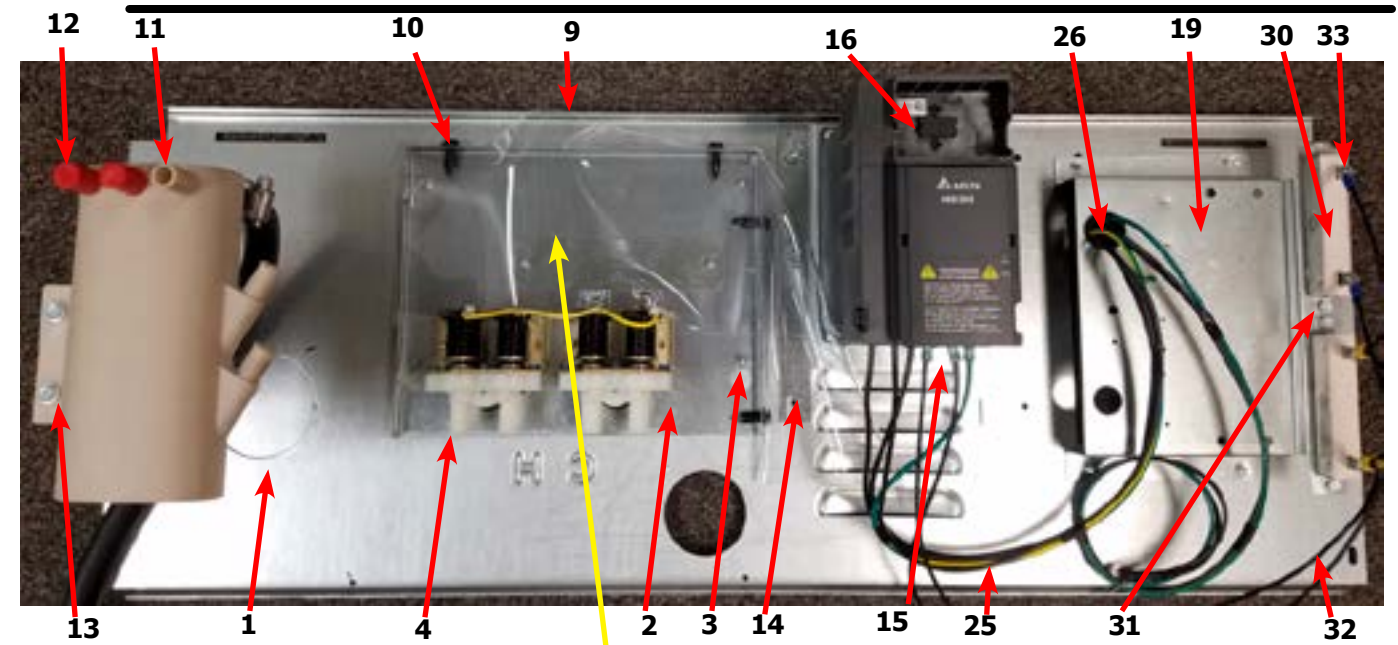

T-1200 Single coil water valve

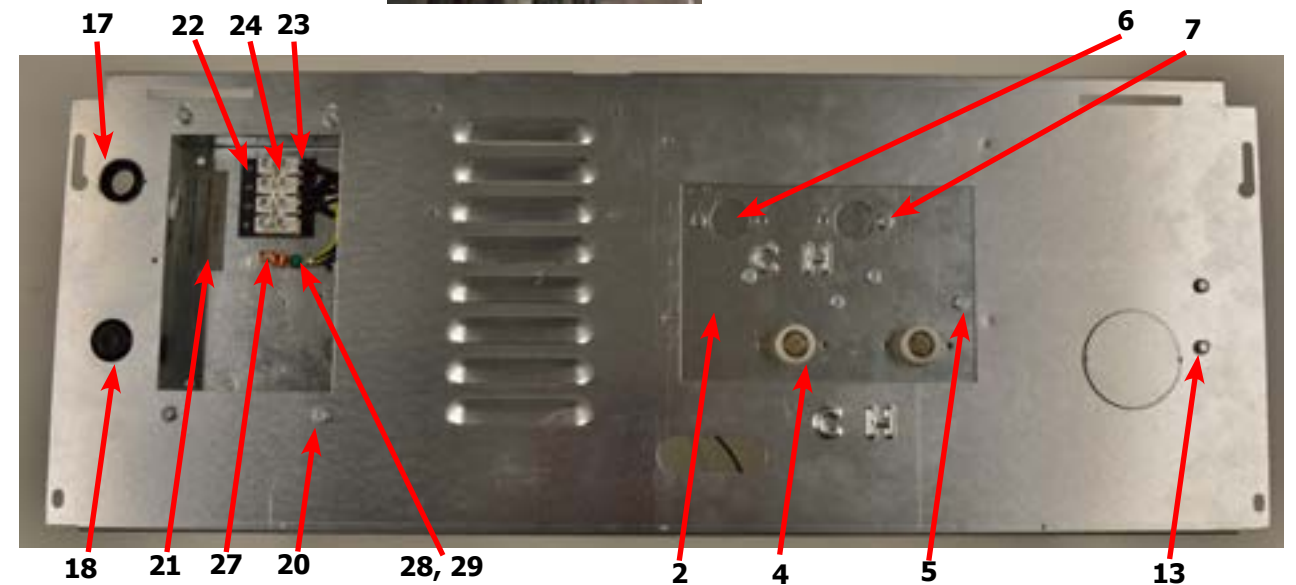
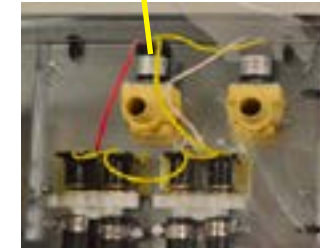

Key	Description	T-1800	QTY
30	Braking resistors (160 ohm)	9483-004-003	2
31	Screw-#10Bx1/2	9545-008-026	4
32	Wire Assy, Jumper	8220-117-003	2
33	Screw, #6-32x5/16	9545-044-006	4
	Nut, #6-32	8640-411-003	4
*	Cover Controls	9074-267-001	1
*	Screw-#10Bx1/2	9545-008-026	1
*	Label-Warning, Notice	8502-761-001	1

Water Inlet Valve Breakdown Part # by Model

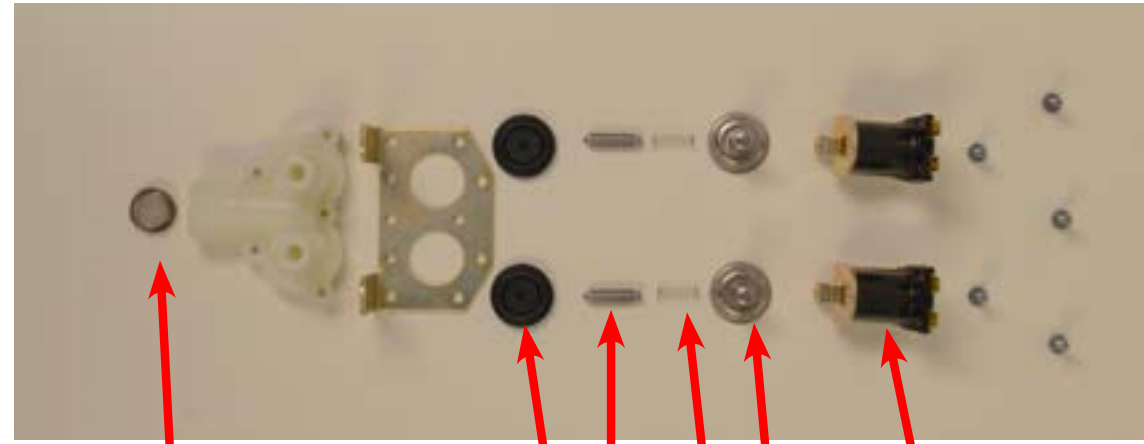

Key	Description	T-1800	QTY
*	Valve, Water Inlet (includes 1 thru 6) - Invensys	9379-183-012	2
1	Screen, Inlet end of valve	9555-056-001	2
2	Coil Assy., 120 V Invensys	9089-017-001	2
3	Diaphragm Invensys (EPDM)	9118-049-001	2
3	Diaphragm Invensys (Viton)	9118-049-002	2
3	Diaphragm Invensys (EPDM NSF)	9118-049-003	2
4	Guide, Solenoid Invensys	9211-021-002	2
5	Armature Invensys	9015-008-001	2
6	Spring, Armature Invensys	9534-298-001	2
*	Wiring Harness	9627-795-005	1

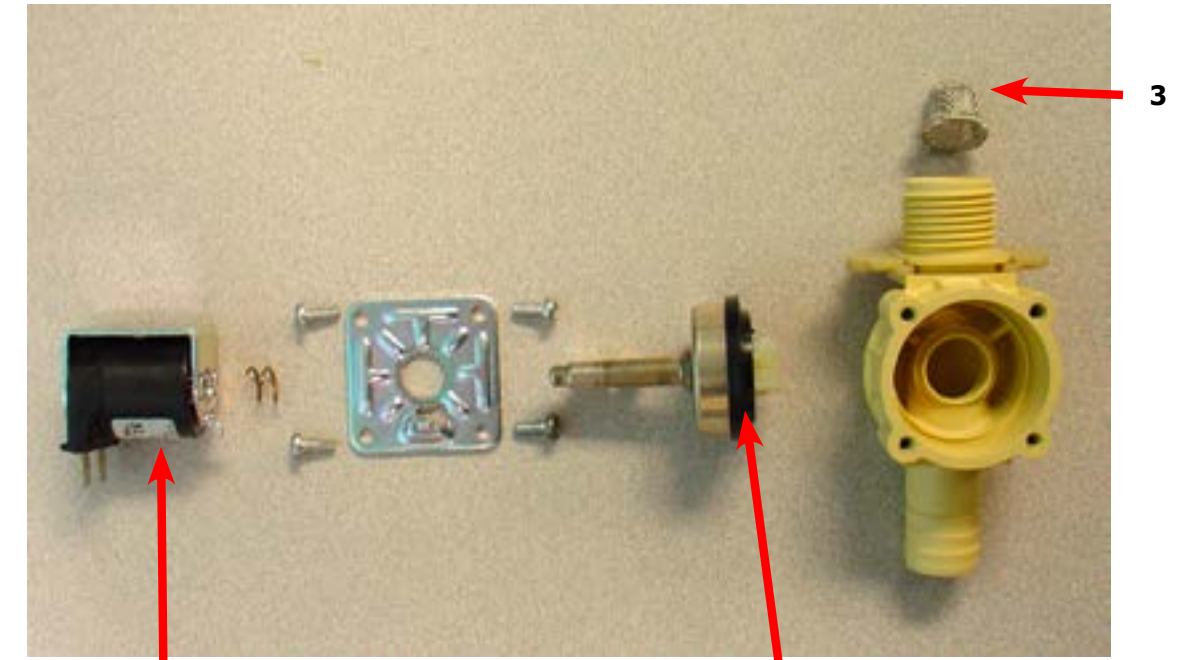

Key	Description	T-1800	QTY
*	Single Coil Water Valve Mueller	9379-194-001	1
1	Valve Water Body Complete (no coil)	9379-194-002	1
2	Diaphragm Mueller	9118-055-001	1
3	Filter Mueller	9183-046-001	1
4	Coil Mueller	9089-051-001	1

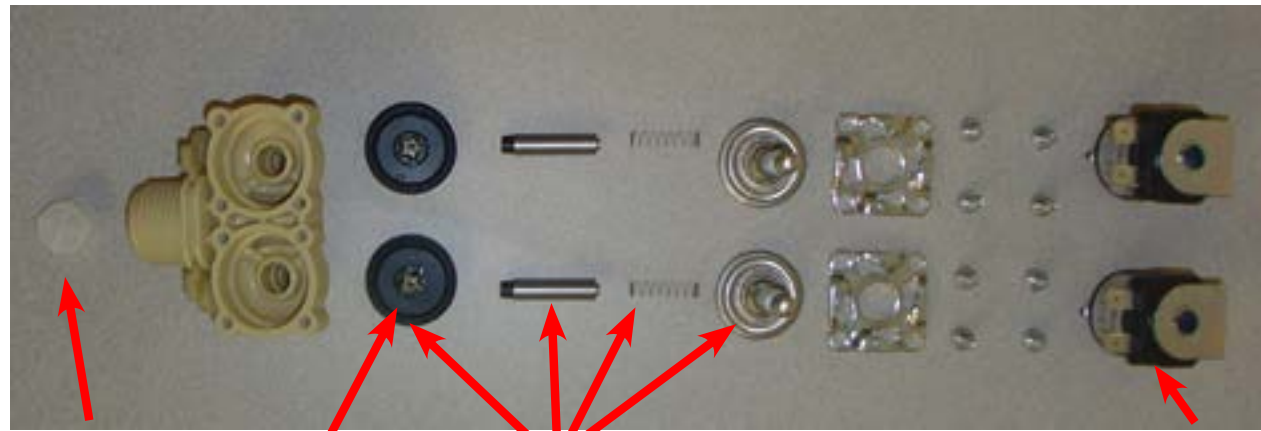

Optional Water Valve

Key	Description	T-1800	QTY
*	Dual Coil Water Valve Mueller	9379-192-001	1
7	Valve Water Body Complete(no coil)	9379-192-002	1
8	Diaphragm Mueller	9118-054-001	2
9	Filter Mueller	9183-046-001	2
10	Coil Mueller	9089-051-001	2
11	Diaphragm Assembly Mueller Includes	9785-001-001	2

Chassis and Drain Part # by Model

Key	Description	T-1800	QTY
1	Base Assy,Frame	9945-158-002	1
2	Outer Tub Assy	9930-187-001	1
*	Tub & Cylinder Assy	9869-046-001	1
3	Tub Front	9974-012-001	1
*	Gasket, Tub Front	9206-421-003	1
4	Ring Assy, Tub Mtg-Front Clamp	9950-061-001	1
5	Bolt, Top Front Ring 3/8"-16 x 3"	9545-029-009	1
6	Nut C Series 3/8"-16	8640-415-001	1
7	Bolt, 1/2" -13 x 2" (Tub Mounting to Frame)	9545-017-013	2
8	Nut, Wizloc 1/2" x 13	8640-417-005	2
9	Washer, Flat 1/2"	8641-581-026	2
10	Hose, Tub to Drain Valve	9242-456-001	1
11	Clamp, Hose (Tub to Drain Valve)	8654-117-014	2
12	Valve, Drain	9379-202-001	1
*	Screw, Valve to Base 1/4ABx3/4	9545-030-002	2
*	Washer, Flat 1/4	8641-581-018	4
13	Hose, Drain Valve to Tube	9242-457-002	1
*	Clamp, Hose (Drain Valve to Tube)	8654-117-014	2
14	Tube Assy, Drain	9915-129-002	1
15	Clamp, Hose (Tube to Frame Bracket)	8654-117-014	1
*	Bracket, Drain Tube	9029-067-004	1
*	Screw Tube (Bracket to Base 1/4Bx3/4)	9545-030-002	4
16	Hose, Overflow Tub To Drain Tube	9942-449-005	1
*	Clamp, Hose	8654-117-018	1
*	Tube, Suds overflow	9242-463-006	1
*	Clamp, Hose	8654-117-008	2
17	Hose, Pressure switch	9242-175-003	1
	Clamp, Overflow Hose	8654-117-015	1

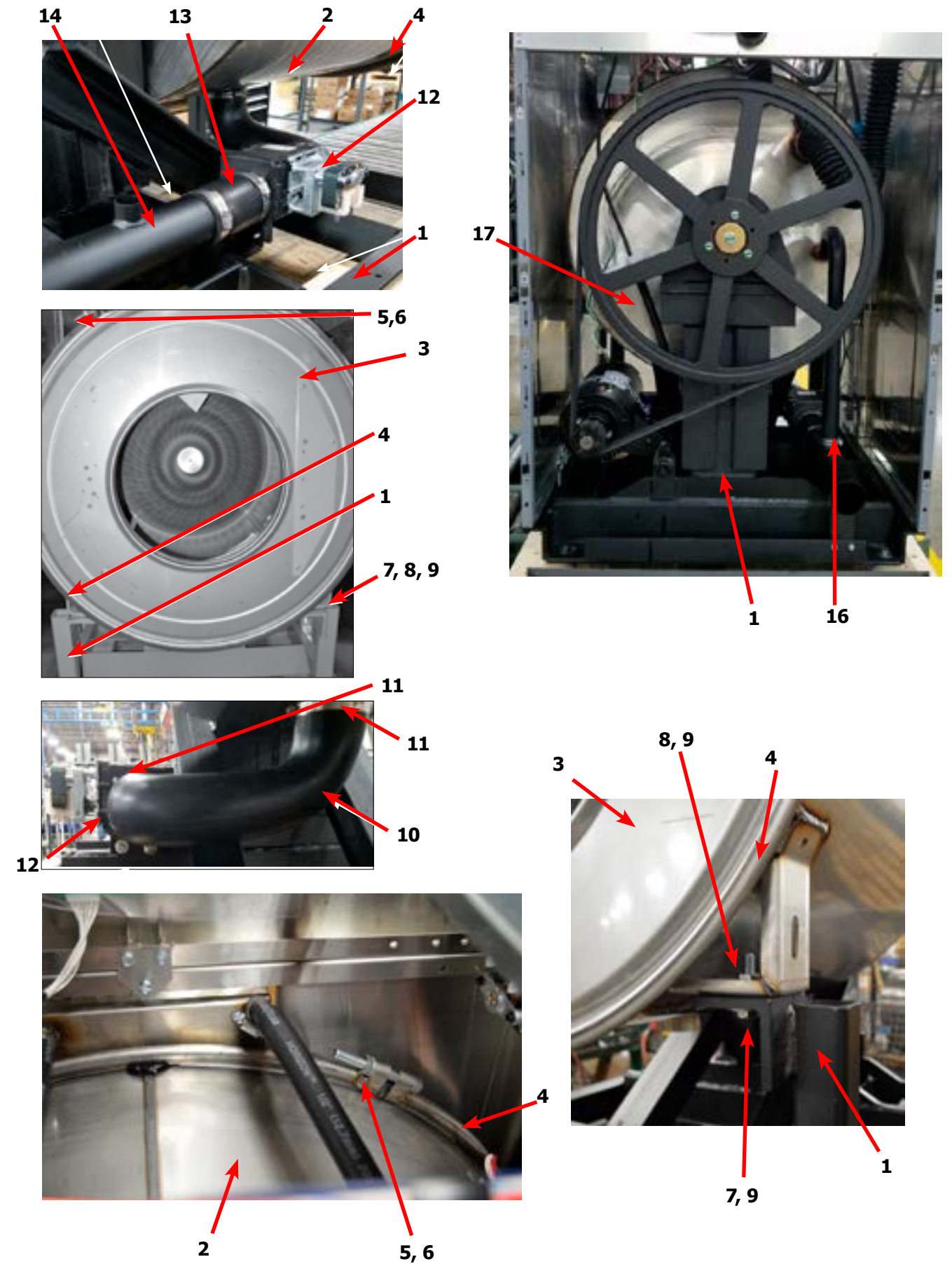

Key	Description	T-1800	
	Contrlsasy-trgh, opl,60hz	9857-301-001	1
1	Troughassy-control	9839-019-001	1
2	Transformer-dualsecondary	8711-017-001	1
*	Screw-hxwshrhnduct,#10bx1/2	9545-008-026	4
*	Lockwasher #10	8641-582-006	4
3	Terminalblockassembly-power	9897-026-005	2
*	Screw-panhdcr,#8abx1/2	9545-045-012	4
*	Wiringharn-ctrl.graph,can,wshr	9627-922-002	1
4	Pcbassy-maincontrol	9799-027-001	1
5	Pcbassy-relay	9799-028-001	2
*	Screw-hxwshrhnduct,#10bx1/2	9545-008-026	12
6	Wiringharness-main,t-650-1450	9627-933-001	1
7	Wiringharness-chemical,v2.0wshr	9627-927-001	1
8	Wireasy,2.0,	8220-158-038	1
9	Wiringharness-drsw/vfd,stp	9627-928-004	1
10	Clamp-cable,3/16"	8654-125-005	1
*	Screw-hxwshrhnd,8bx1/4	9545-045-001	1
*	Wiringharness-cntrl/relay,v2.0	9627-921-001	2
11	Wireasy-jumper,v2.0,relaypcb	8220-159-005	1
12	Wireasy-jumper,v2.0,relaypcb	8220-159-006	1
*	Screw-hxwshrhds,10-32tx1/2grn	9545-008-027	2
*	Lockwasher #10	8641-582-006	2
*	Standoff-twistlok	9527-002-002	4
13	Sensorassy-pressure,2level	9732-315-001	1
*	Support-pcb,3/8",edge Holding	9548-285-001	4
14	Wiringharness-ps,t-650-1450	9627-926-001	1
*	Wireasy-org,71/2"	8220-062-052	1
*	Wireasy-wht/org,9"	8220-062-053	1
15	Fuseholderassembly	9200-001-002	2
*	Fuse-2a,slow,1/4x1-1/4	8636-018-005	1
*	Fuse-1.5a,fast,1/4x1-1/4	8636-018-001	1
*	Label-fuse,2a	8502-716-003	1
*	Label-fuse,1.5a	8502-716-001	1
*	Wireasy-red,71/2"	8220-062-059	2
*	Wireasy-org,71/2"	8220-062-052	2
*	Label-waterlevelsettings,opl	8502-775-001	1
16	Elecperiph-powersupply,12v	9150-054-001	1
*	Screw-pnhdcr,6bx3/8	9545-031-005	2
17	Wiringharness-pwrsup,v2.0wshr	9627-923-001	1
18	Wiringharness-thermist,v2.0wsh	9627-930-001	1
*	Screw-hxwshrhnduct,#10bx1/2	9545-008-026	5
19	Standoff-wiresaddlew/arrowhead	9527-007-001	1
20	Support,Trough	9081-173-001	1
21	Channel-trough,mtg	9081-155-001	1

Electrical Components - Top Compartment

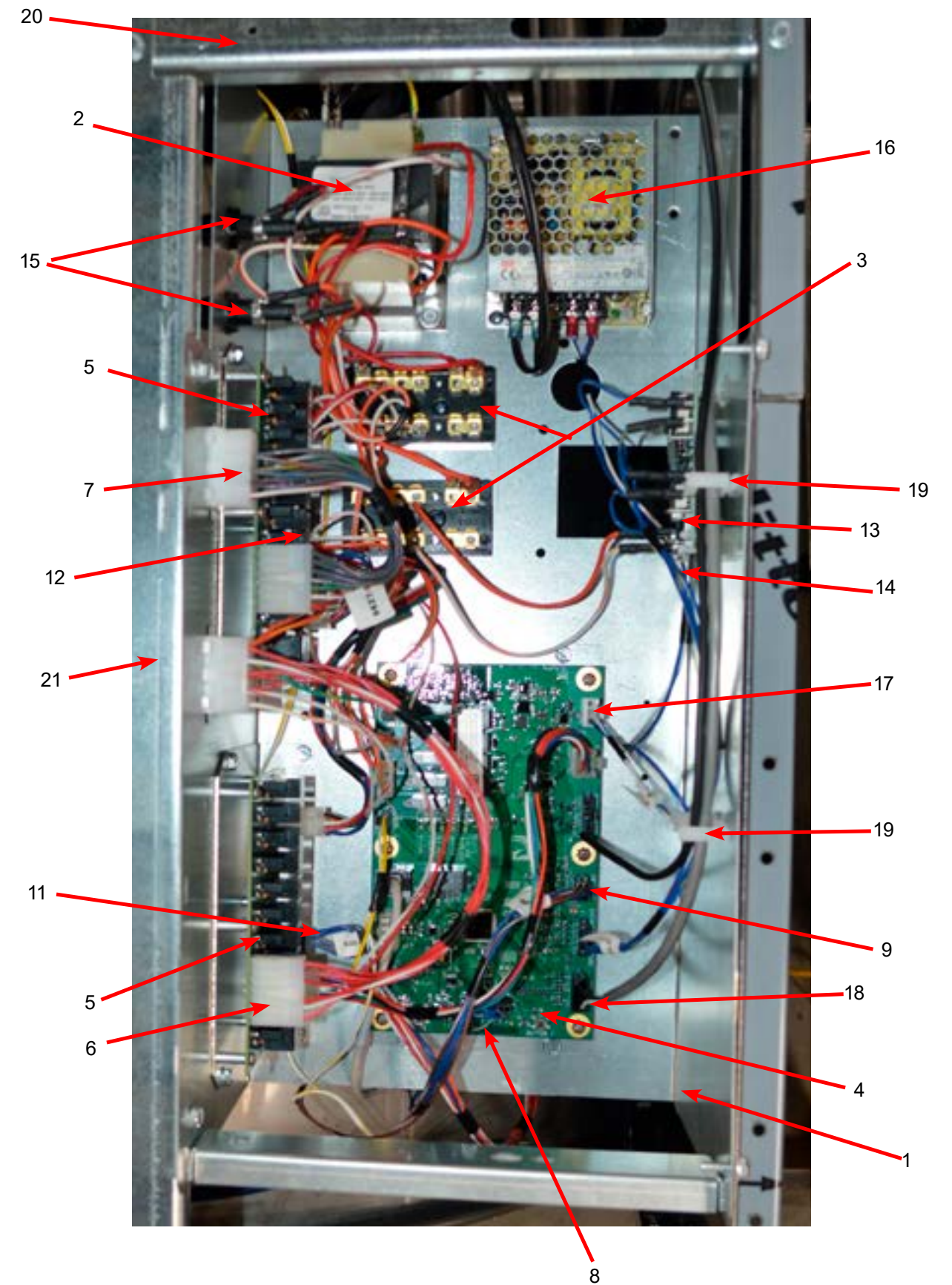

Key	Description	T-1800	QTY
1	Panel Control Assembly(panel only)	9989-601-001	1
*	Screw-Hxwshrhnduct #10Bx 1/2" (Control Panel To side Panel)	9545-008-026	4
*	Plate -Latch, Top	9452-625-001	AR
*	Nut Hexkeys #8-32	8640-412-005	AR
*	Post-locator,top		2
*	Nut-hexkeys,#6-32		2
*	Locator Panel	9355-001-001	AR
*	Screw FillHDCR 10Bx1/2" Guide	9545-008-023	AR
*	Shield, PCB	9550-184-001	1
*	Nut, #8-32	8640-412-005	3
2	Button-control,2.0,opl	9035-063-001	1
3	Window-display,lcd(w/gasket)	9635-021-002	1
4	Contrlassy-display,2.0,opl,wsh	9857-230-003	1
5	Nut-hexkeys,#6-32	8640-411-003	4
6	Cableassy-usb,snopin	9806-024-001	1
*	Wiringharness-doorlock	9627-936-004	1
*	Harness, P5/Pressure Switch	9627-926-001	1
*	Kit-Emergency Stop, O-Series (includes #X, #Y)	9732-223-004	1
7	Button-emergencystop,w/latch	9035-061-002	1
8	Spacer-pcb,#8x1/8	9538-157-005	2
9	Plate-mounting,stopbutton	9452-725-001	1
10	Nut-hexkeys,#8-32	8640-412-005	2
11	Switch-contactblock,dpst,nc	9539-499-001	1
*	Nameplate,Control Panel (one piece) Black	9412-278-001	1
12	Motor Ass'y, Door Locking (see Door Lock Group for parts breakdown)	9892-015-003	1
13	Thermoactuator - 24VAC	9586-001-003	2
14	Hex Nuts (mounting Door Lockassy. to control panel)	8640-412-005	4
15	Nut-Spring	8640-399-008	2
16	Screw, #10B x 1/2	9545-008-026	2
*	Anchor-wiretie,adhesive	9004-007-001	2
*	Strap-tie,adjustableratchet	9544-040-001	2
17	Doorlockassembly-complete	9885-024-001	1
	Shim-doorlock,thin	9552-037-001	3
	Screw-hxhdcap,1/4-20x3/4	9545-018-014	3
	Lockwasher-exttooth,1/4	8641-582-007	3
18	Rod-pull,doorlock	9497-225-016	1

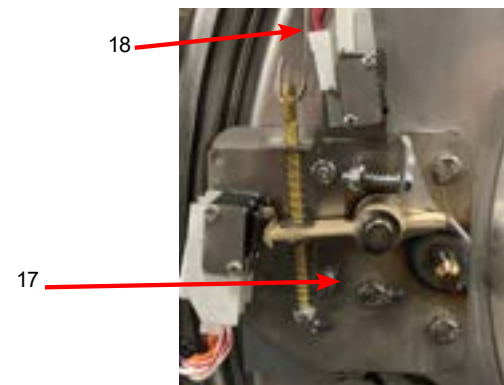

Control Panel Part # by Model

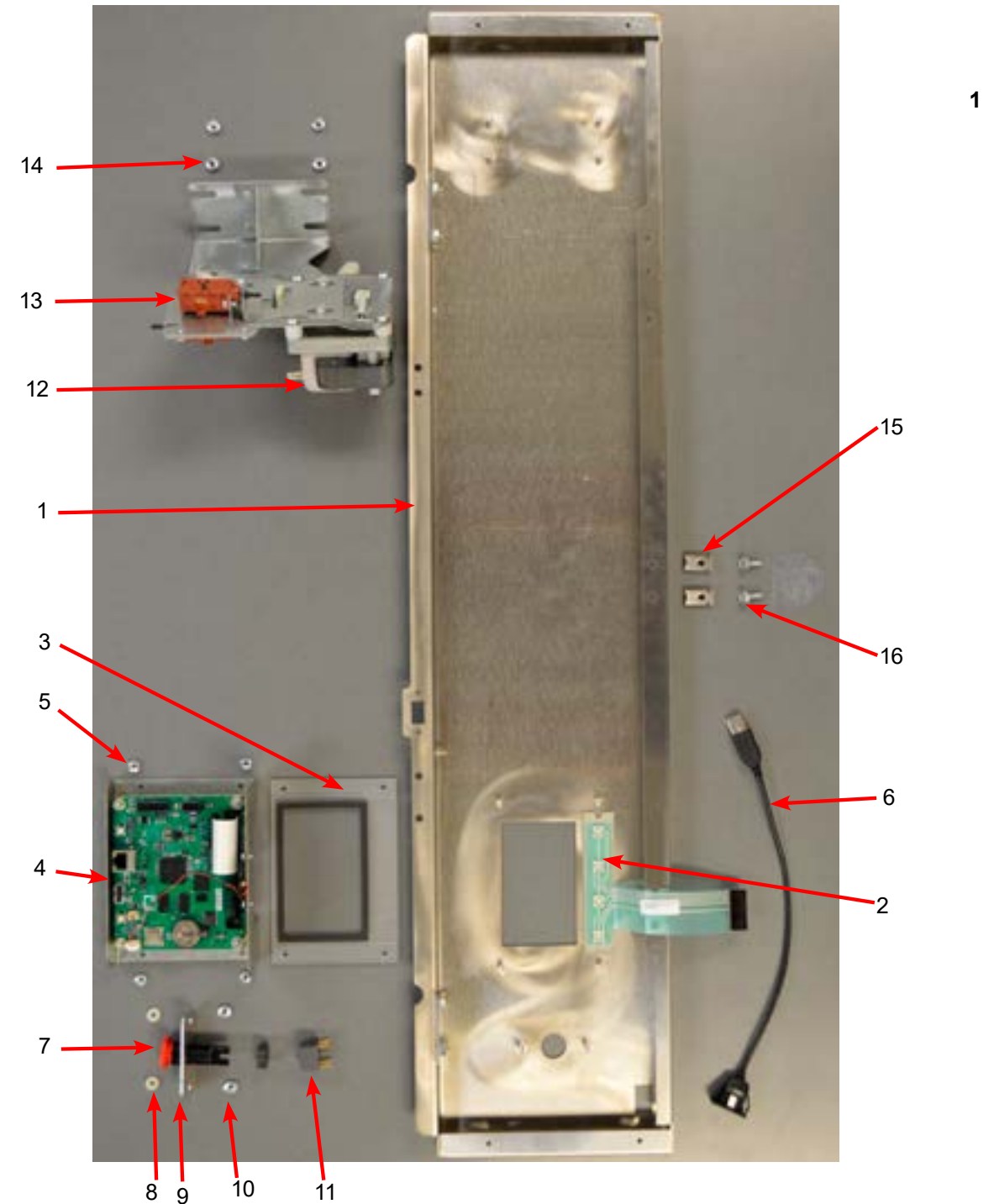

Labels and Diagrams

Key	Description	T-1800	QTY
*	Wiring Diagram and Schematic, Coin	9506-871-001	1
*	Transient Voltage Surge Suppressor Infomational	8507-330-001	1
*	Label High Voltage Warning	8502-614-004	1
*	Label Fusing & Installation	8502-619-003	1
*	Label Quality	8511-001-002	1
1	Label Warning Door Opening (Blue)	8502-757-002	1
1	Label Warning Door Opening (Black)	8502-757-001	1
2	Label Warning Risk of Injury (Blue)	8502-759-002	1
2	Label Warning Risk of Injury (Black)	8502-759-001	1
3	Label Dispenser (Blue)	8502-756-002	1
3	Label Dispenser (Black)	8502-756-001	1
*	Booklet Owners	8514-296-001	1



Section 11: Maintenance