

O-Series

Soft Mount



O-Series Soft Mount OPL Express Plus (400G) Washers Service Manual







DEXTER[®]
LAUNDRY



USE THE BLUE TABS LOCATED ON THE RIGHT AND LEFT SIDES OF THE FOLLOWING DOCUMENT TO ADVANCE TO EACH SECTION.

Equipment Safety Warnings Symbols and Terminology Used in this Equipment

⚠ DANGER	Indicates an imminently hazardous situation, which if not avoided, will result in death or serious injury.
⚠ WARNING	Indicates a potentially hazardous situation, which if not avoided could result in death or serious injury.
⚠ CAUTION	Indicates a potentially hazardous situation which, if not avoided, may result in minor or moderate injury. It may also be used to alert against unsafe practices. Minor burns, pinch points that result in bruises and minor chemical irritation.
NOTICE	Indicates information or a company policy that relates directly or indirectly to the safety of personnel or protection of property.
	This is the user caution symbol. It indicates a condition where damage to the equipment resulting in injury to the operator could occur if operational procedures are not followed. TO REDUCE THE RISK OF DAMAGE OR INJURY , refer to accompanying documents; follow all steps or procedures as instructed.
	This is the electrical hazard symbol. It indicates that there are DANGEROUS HIGH VOLTAGES PRESENT inside the enclosure of this product. TO REDUCE THE RISK OF FIRE OR ELECTRIC SHOCK , do not attempt to open the enclosure or gain access to areas where you are not instructed to do so. REFER SERVICING TO QUALIFIED SERVICE PERSONNEL ONLY
	Caution! There are sharp edges on various sheet metal parts internal to the enclosure. Use safety consciousness when placing or moving your hands while working in the interior of this equipment.
	Caution! To reduce the risk of damage to the Water Inlet Valve, do not supply inlet water with a temperature that exceeds 70° C. Caution! To reduce the risk of fire or explosion, do not operate this equipment in any hazardous classified (ATEX) environment.

Equipment Safety Warnings

Symbols and Terminology Used in this Equipment



Warning! Do not operate equipment if door glass is damaged in any way.



Warning! Keep clear of rotating parts.



Prohibited! Do not enter this equipment or space.



Prohibited! Do not step or stand on this equipment.



Prohibited! Do not operate without all guards and covers in place.



Prohibited! Do not operate without all guards and covers in place.



Prohibited! Do not wash clothing impregnated with flammable liquids (petrochemical).



Prohibited! Do not allow children to play in or around equipment.

	Indicates an imminently hazardous situation, which if not avoided, <u>will result</u> in death or serious injury.
	Indicates a potentially hazardous situation, which if not avoided <u>could result</u> in death or serious injury.
	Indicates a potentially hazardous situation which, if not avoided, <u>may result</u> in minor or moderate injury. It may also be used to alert against unsafe practices. Minor burns, pinch points that result in bruises and minor chemical irritation.
	Indicates information or a company policy that relates directly or indirectly to the safety of personnel or protection of property.
	This is the user caution symbol. It indicates a condition where damage to the equipment resulting in injury to the operator could occur if operational procedures are not followed. TO REDUCE THE RISK OF DAMAGE OR INJURY, refer to accompanying documents; follow all steps or procedures as instructed.
	This is the electrical hazard symbol. It indicates that there are DANGEROUS HIGH VOLTAGES PRESENT inside the enclosure of this product. TO REDUCE THE RISK OF FIRE OR ELECTRIC SHOCK, do not attempt to open the enclosure or gain access to areas where you are not instructed to do so. REFER SERVICING TO QUALIFIED SERVICE PERSONNEL ONLY.
	Caution! To reduce the risk of fire or explosion, do not operate this equipment in any hazardous classified (ATEX) environment.



WARNING

	<ul style="list-style-type: none"> All washers must be installed in accordance to all applicable electrical, plumbing and all other local codes. These installation and operation instructions are for use by qualified personnel only. To avoid injury and electrical shock, do not perform any servicing other than that contained in the installation and operation instructions, unless qualified.
	Do not install washers in an explosive atmosphere.
	<ul style="list-style-type: none"> Care must be stressed with all foundation work to ensure a stable unit installation, eliminating possibilities of excessive vibration. Foundation must be level within 13 mm to ensure proper washer operation.
	Do not operate washer if door glass is damaged in any way.
	Do not wash clothing impregnated with flammable liquids (petrochemical).



WARNING







 	Children should be supervised to ensure they do not operate or play in or around equipment.
	Keep all panels in place to protect against electrical shock and injury and add rigidity to washer.

This appliance is not intended for use by persons (including children) with reduced physical, sensory or mental capabilities, or lack of experience and knowledge, unless they have been given supervision or instruction concerning use of the appliance by a person responsible for their safety.

A washer should not be allowed to operate if any of the following occur:

- Excessive high water level.
- Machine is not connected to a properly earthed circuit.
- Door does not remain securely locked during the entire cycle.
- Vibration or shaking from an inadequate mounting or foundation

	Warning! Do not operate equipment if door glass is damaged in any way.
	Warning! Keep clear of rotating parts.
	Prohibited! Do not enter this equipment or space.
	Prohibited! Do not step or stand on this equipment.
	Prohibited! Do not operate without all guards and covers in place.
	Prohibited! Do not operate without all guards and covers in place.
	Prohibited! Do not wash clothing impregnated with flammable liquids (petrochemical).
	Prohibited! Do not allow children to play in or around equipment.

	Prohibited! Do not attempt to open, touch, or proceed before referring to the manual or unless qualified.
	Mandatory! Read all supporting documentation before operating or maintaining equipment.
	Mandatory! Disconnect power before servicing equipment.
	Mandatory! Lock out and tag out before servicing this equipment.
	Mandatory! Disconnect water supply before servicing equipment.
	Mandatory! Children should be supervised to ensure they do not operate equipment.

Notes

Lined area for handwritten notes.

Dexter Safety Guidelines

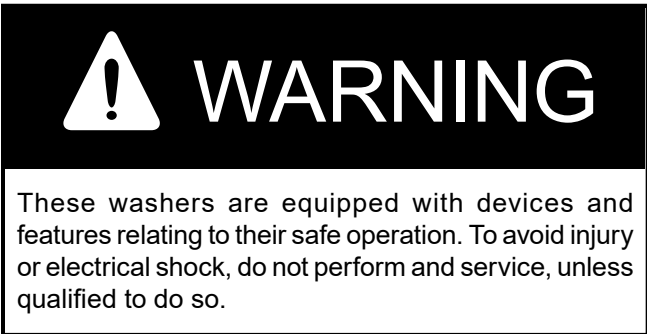

FOR SAFETY

1. Always shut off power and water supply and also discharge capacitors before servicing.
2. Do not overload the washer.
3. Do not attempt to open door if cylinder is in motion or contains water.
4. Do not mechanically force or override door lock in any way.
5. Do not bypass any safety devices of this washer.
6. Do not use volatile or flammable substances in or near this washer.
7. Keep all panels in place. They protect against shock and injury and add rigidity to the washer.

A machine should not be allowed to operated if any of the following occur:

- Excessively high water level.
- Machine is not connected to a properly grounded circuit.
- Loading door does not remain securely locked during the entire cycle.
- Vibration or shaking from an inadequate mounting or foundation.

To activate your warranty, be sure to return your red warranty form to the factory. Please have serial number and model ready when calling for assistance.

Table of Contents

Section 1:
Machine Specifications

S-975..... 15
S-975 Installation 16

Section 2:
Machine Installation & Operating Instructions

Basic Installation 18-21
Electrical Connections & Fusing Requirements...
21 - 23
Machine Chemical Connection 24
Operating Instructions..... 25
Emergency Stop Button..... 26

Section 3:
Machine Programming Instructions

Programming 30-41

Section 4:
Trouble Shooting

Common Troubleshooting Solutions 43-45
Troubleshooting Machine Fault
Errors Pages 46-54
Motor Resistance Chart.....56

Section 5:
Machine Service Procedures

Top Panel Removal..... 59
Front Panel Removal 59
Back Panel Removal..... 59
Drain Valve Access 59
Drain Valve Cleaning 59
Detergent Dispenser 59
Injection Assembly 59
Water Valves 60
Door Lock Assembly Operation..... 60
Accessing the Door Lock Assembly..... 60
Removal of the Door Lock Assembly 60
Door Lock Assembly Release 60

Door Lock Assembly in Power Outage	60	Section 8:	
Door Glass Gasket Removal & Install	61	Parts Data	
Max Displacement Switch Reset.....	61	S-Series Accessories.....	81
Adjusting the Loading Door	62	Wiring Harness Part # by Model	84
Loading Door Removal	62	Cabinet and Front Panel Parts Group	85-86
Loading Door Hinge Removal	62	Soap Dish.....	87
Control Panel Name Plate Decal.....	63	Rear View Access Parts Group.....	89-90
Name Plate Removal	63	Cylinder, Seals & Bearings Parts Group ...	91-92
Re-Installation of Name Plate.....	63	Loading Door & Door Lock Group.....	93-94
Drive Belt Removal	64	Water Inlet Part # by Model.....	95-96
Drive Belt Tensioning.....	64	Water Inlet Valve Breakdown	97-98
Cylinder Assembly	65	Rear Channel Parts Group.....	99-100
Bearing Housing & Water Seals	65-66	Cradle & Base Parts Group.....	101-102
Cylinder Reassembly.....	67	Drain Valve Breakdown	104
Bolt Torque Chart.....	68	Chassis and Drain Parts Group	105-106
		Electrical Components -	
Section 6:		Top Compartment.....	107-108
Control Mounting Trough	69	Control Panel Parts Group	109-110
Main Data Communication Cable	69	Labels and Diagrams	111
Fuses.....	69		
Controls Transformer	69	Section 9:	
Main Control/Relay Printed Circuit Board	69	50 Hz	
LED Printed Circuit Board Temperature & Start/ Display Push Button.....	69	Section 10:	
Pressure Switch.....	69	Maintenance	
Power Connection Terminal Block	70	Preventative Maintenance.....	118
Delta Variable Frequency Drive.....	70		
Delta VFD Motor Leads	70		
Delta VFD Dynamic Braking Resistors	70		
Delta VFD Cooling Fan.....	70		
Water Pressure Switch Sensor.....	71-72		
Section 7:			
Machine Electrical & Wiring Schematics			
Start Circuit	75		
Agitation Circuit.....	76		
Fill Circuit.....	76		
Soap Dish flush / Injection Signals	76		
Level Achieved / Stage Completion / Drain.....	77		
Spin and Extract Circuit	77		
End of Cycle Circuit	77		
Diagrams & Schematics	79-80		



Section 1: Machine Specifications

Specifications for below models are outlined in this book:

- S-675 WS0675XB-12EO 208-240 volts 60Hz Single or Three Phase
- S-975 WS0975XB-12EO 208-240 volts 60hz Single or Three Phase

		S-675	
Capacity	Dry Weight Capacity - lb (kg)	40	18.1
	Cylinder Volume - cu ft (L)	6	170
Speed	High Extract Speed - g (RPM)	400	1061
	Motor Size - hp (kW)	3	2.2
Dimensions	Cabinet Height - in (cm)	52 9/16	133.5
	Cabinet Width - in (cm)	33	83.8
	Cabinet Depth - in (cm)	40	101.6
	Door Opening - in (cm)	15 1/4	38.7
	Floor to Door Bottom - in (cm)	19 15/16	50.7
	Cylinder Diameter - in (cm)	25	63.5
	Cylinder Depth - in (cm)	21 1/8	53.7
	Static Load Transmitted - lb (kg)	1040	471.7
	Dynamic Load Transmitted - lb (kg)	368	166.9
	Dynamic Load Frequency - Hz	17.7	-
Weight	Net Weight - lb (kg)	902	409.1
	Shipping Weight - lb (kg)	952	431.8
Shipping Information	Shipping Height - lb (kg)	58 3/4	149.2
	Shipping Width - lb (kg)	34 3/4	88.3
	Shipping Depth - lb (kg)	50	127
	Water	Water Inlet Size - in (mm)	3/4
Water	Pressure (min/max) - psi (kPa)	30-120	207-827
	Flow Rate - gal/min (L/min)	9	34
	Drain Diameter (OD) - in (cm)	3	7.6
	Floor to Center of Drain - in (cm)	4 1/8	10.5
Electrical	Model	Volts/Hz/Phase/Wiring	Crct. Brkr. Amps/Runing Amps/Wire Size
	-12	208-240/60/1/2 wire + ground	15/10/#12
		208-240/60/3/3 wire + ground	15/10/#12
-39	230/20/1/2 wire + ground	15/10/3.5mm2	
Installation	Minimum Clearance Between Machines - in (cm)	1/2	1.3
	Minimum Clearance Behind Machines - in (cm)	24	61

S-675 Machine Dimensions

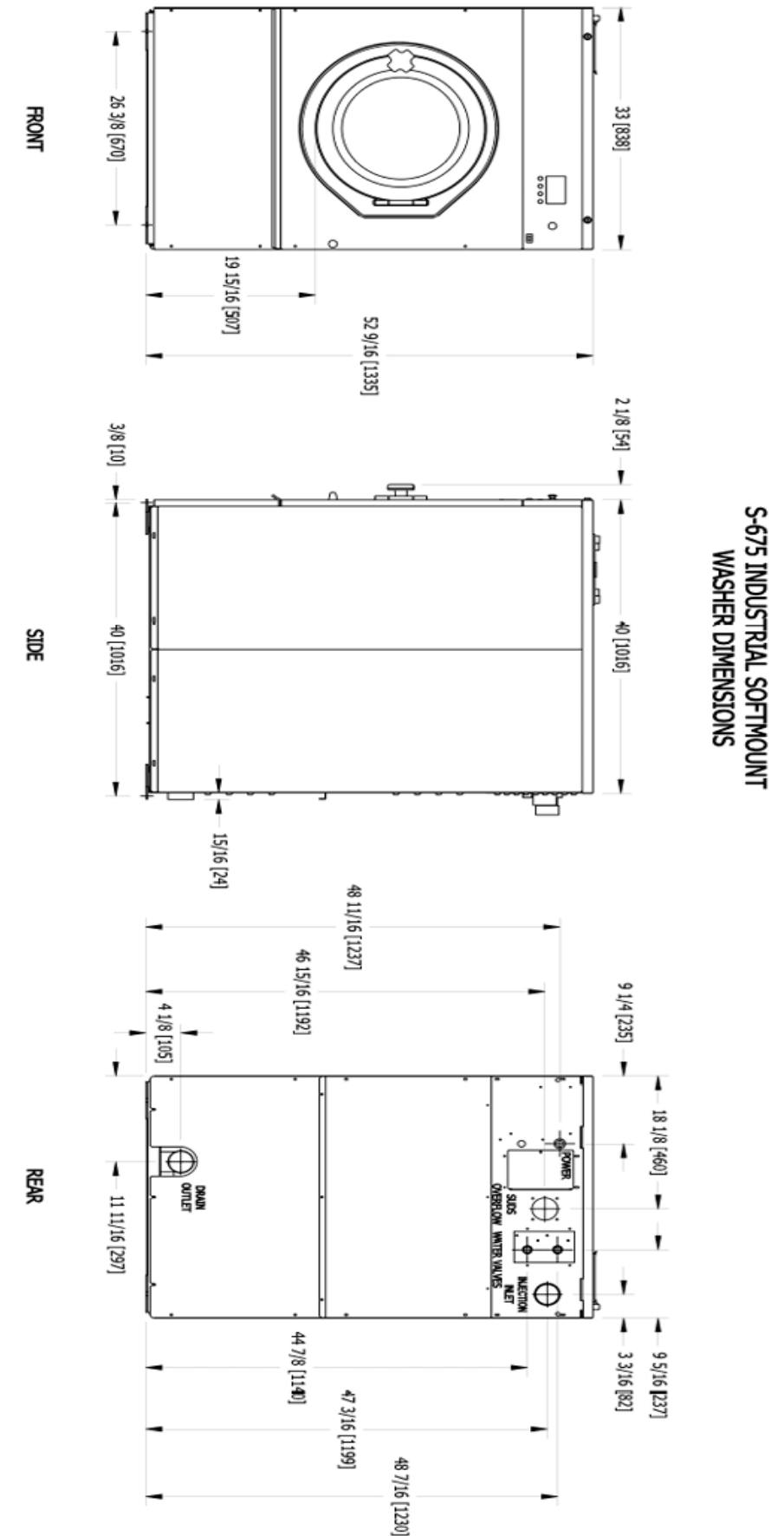

S-975 Machine Specifications

		S-975	
Capacity	Dry Weight Capacity - lb (kg)	60	(27.2)
	Cylinder Volume - cu ft (L)	9	(254.9)
Speed	High Extract Speed - g (RPM)	400	(969)
	Intermediate Extract Speed - g (RPM)	60	(375)
	Washing Speed - g (RPM)	0.9	(43)
	Motor Size - hp (kW)	6.7	(5)
Dimensions	Cabinet Height - in (cm)	58	(147.3)
	Cabinet Width - in (cm)	38 1/4	(97.2)
	Cabinet Depth - in (cm)	43	(109.2)
	Door Opening - in (cm)	19 1/4	(48.9)
	Floor to Door Bottom - in (cm)	21 3/8	(54.4)
	Cylinder Diameter - in (cm)	30	(76.2)
	Cylinder Depth - in (cm)	22	(55.9)
	Static Load Transmitted - lb (kg)	1515	(687.2)
	Dynamic Load Transmitted - lb (kg)	460	(208.7)
	Dynamic Load Frequency - Hz	16.1	-
	Weight	Net Weight - lb (kg)	1250
Shipping Weight - lb (kg)		1300	(589.7)
Shipping	Shipping Height - in (cm)	64 1/4	(163.2)
	Shipping Width - in (cm)	40	(101.6)
	Shipping Depth - in (cm)	50	(127)
	Water	Water Inlet Size - in (mm)	3/4
	Pressure (min-max) - psi (kPa)	30-120	(207-827)
	Flow Rate - gal/min (L/min)	9 & 12	(34 & 45)
	Drain Diameter (O.D.) - in (cm)	3	(7.6)
	Floor to Center of Drain - in (cm)	4 1/8	(10.5)
Electrical	Model	Volts / Hz / Phase / Wiring	Circuit Breaker Amps / Running Amps / Wire Size
	-12	208-240 / 60 / 1 / 2 wire + ground 208-240 / 60 / 3 / 3 wire + ground	30 / 15 / #10
Installation	Min. Clearance Between Machines - in (cm)	1/2	(1.3)
	Min. Clearance Behind Machines - in (cm)	24	(61)

S-975 Machine Dimensions

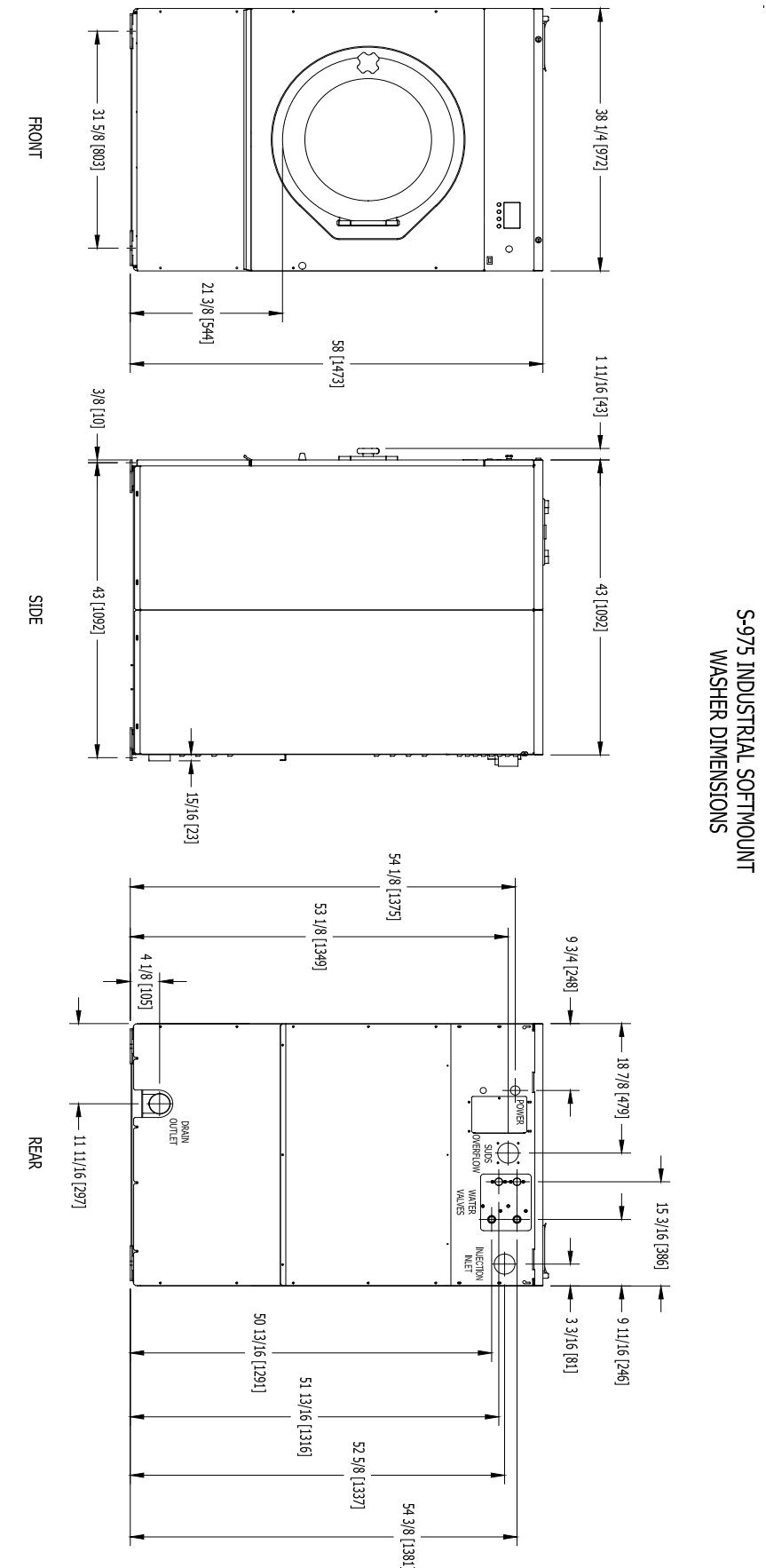

Installation & Operation

All washers must be installed in accordance with all local, state, and national building, electrical, and plumbing codes in effect in the area.

2.1 FLOORING REQUIREMENTS

It is recommended that this machine be installed on a level concrete floor. Concrete should have a minimum strength of 4,000 psi.

Do not install the washer on suspended floors or above open basements without consulting with a qualified structural engineer. The flooring must be adequate to support the static and dynamic loading of the washer (see specifications section).

Allow a minimum of 24 inches (610 mm) of clearance behind the rear of the machine to provide access for motor service.

Do not install on any type of anti-vibration materials or devices.

It is recommended to also install two mounting bolts to anchor the machine against possible movement. The anchors should be installed through the 1/2" wide slots in the corner mounting plates on the machine base (using two opposite corners). See machine dimensions section.

2.2 REMOVAL OF SHIPPING BRACES

Do not remove the shipping braces before placing the machine in its installed location.

Do not run the machine with the shipping braces in place. Severe damage and physical injury may occur.

Steps to remove the (5) shipping braces:

- Remove the lower service panel on the front of the washer and the lower panel on the rear of the washer.
- On the rear of the washer, remove the (4) screws that secure the white triangular shaped brace to the frame as shown below:

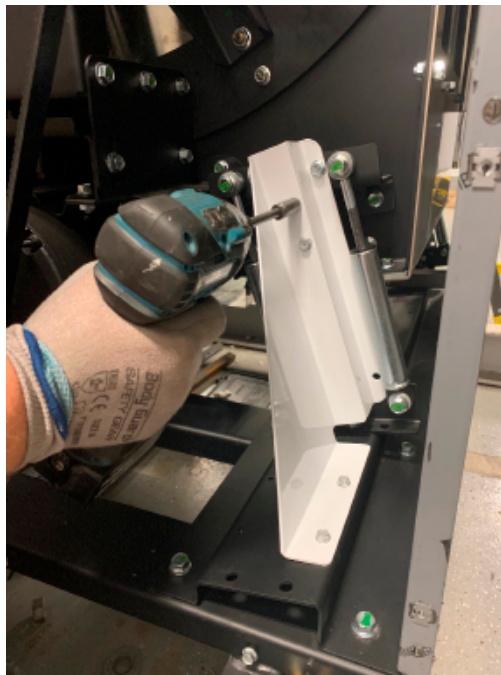

- Next, remove the white hat-shaped brace from this corner of the frame by removing (3) bolts and nuts as shown below (Do not remove or loosen the bolts that secure the dampers (shocks)):



- Next, remove the white hat-shaped brace from the other rear corner of the frame by removing (3) bolts and nuts as shown below (Do not remove or loosen the bolts that secure the dampers (shocks)):



- Next, remove the white hat-shaped brace from the front corner of the frame by removing (3) bolts and nuts as shown below (Do not remove or loosen the bolts that secure the dampers (shocks)):



- Next, remove the white hat-shaped brace from the other front corner of the frame by removing (3) bolts and nuts as shown below (Do not remove or loosen the bolts that secure the dampers (shocks):



- Save all (5) braces and fasteners. If the machine needs to be moved in the future, replace all braces before moving it.
- Re-install the lower service panel on the front of the washer and the lower panel on the rear of the washer.

2.4 PLUMBING

Water supply hoses are provided with each machine. The threaded connections on the hoses are 3/4-11 1/2 NHT.

Separate hot and cold water lines must be supplied to the machine, maintaining 30 psi to 120 psi (207 kPa to 827 kPa) water flow pressure. A 140°F (60°C) hot water supply is recommended for best washing results. Do not exceed 180°F (82°C) water temperature.

2.5 DRAIN

The drain outlet tube size is 3 inches (76 mm) in diameter

Any drain hose used must be lower than the drain valve to assure proper draining.

2.6 PROTECTIVE FILM

The machine may have protective adhesive film on the front control panel label area and on the front, top, and side stainless steel panels. The film may be peeled off before putting the machine into service.

2.7 ELECTRICAL

The Dexter single/three-phase 208-240VAC 60 Hz non-heated washing machines are intended to be permanently installed appliances. No power cord is provided. The machine should be connected to an individual branch circuit not shared by lighting or other equipment. A means for disconnection with a contact separation of at least 1/8" (3 mm) must be provided. The connection should be sheathed in liquid-tight or approved flexible conduit, or equivalent, with conductors of the proper size and insulation. A qualified technician should make such connections in accordance with the wiring diagram. See specification sheet for minimum recommended wire size.

Individual circuit breakers for each unit are required. Do not use ground-fault (earth-fault) circuit breakers or ground-fault (earth-fault) circuit interrupter outlets.

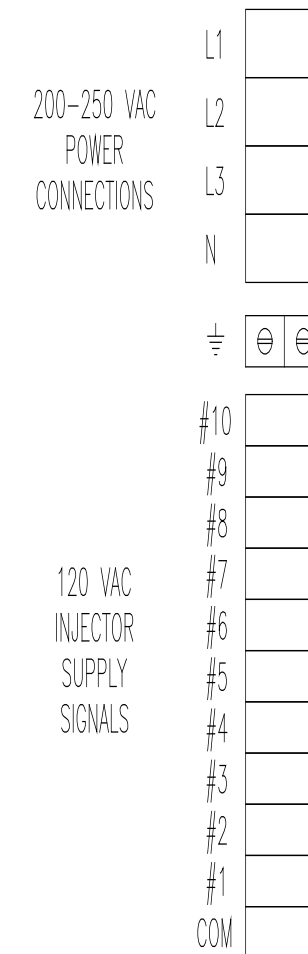

2.7.1 INSTALLING THE ELECTRICAL CONNECTION

2.7.1.1 Disconnect all power to the washer.

2.7.1.2 Remove the terminal block cover on the back of the washer.

2.7.1.3 If power is 208-240V-3PH-60Hz, connect L1, L2, L3 and Ground. If there is a high leg, it must NOT be connected to L1 or L2. However, failure due to a voltage surge on the high leg is not covered by equipment warranty. Contact Dexter Laundry with any questions.

2.7.1.4 If power is 208-240V-1PH-60Hz, connect L1, L2 and Ground.

NOTE: It is important that the grounding screw next to the power terminal block be connected to a good external ground.

2.7.2 FUSING REQUIREMENTS

Single- and Three -phase models:

See specification sheet for required TIME-DELAY (DUAL ELEMENT) FUSE size (or equivalent circuit breaker)

2.7.3 CONTROLS TRANSFORMER (208-240V 60 Hz models only)

The controls transformer is located inside the control trough and steps a range of 208 to 240 volts down to 115 volts and 24 volts. There are two terminals on the controls transformer for the primary (incoming) power. Use the terminal marked "208V" for power supplies between 208 and 219 volts. Use the terminal marked "240V" for power supplies between 220 and 240 volts. Refer to the following for control transformer connections.

CONTROL TRANSFORMER CONNECTIONS

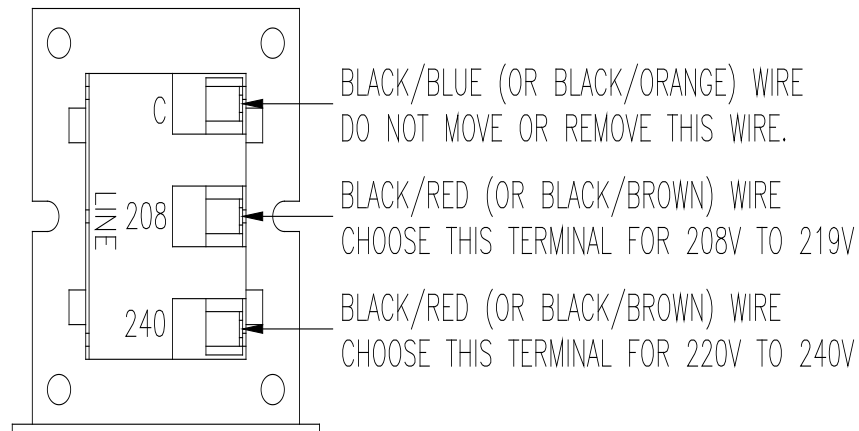

2.8 INJECTION SOURCE CONNECTIONS

The washer control may be programmed to send ten 120VAC output signals for a chemical injection system. The signals are not intended as a power source and must be limited to less than 100 milliamps of current. There is a separate terminal block for connection of the external injection signals. For the injection sources, program codes 1 through 10 and their respective terminal block connections are as shown in the table below.

If required, chemical injection hoses are to be inserted into the injection inlet at the upper right rear of the washer. These hoses should be inserted into the round PVC pipe a distance of a minimum of 22" (56 cm) and a maximum of 26" (66 cm). This will eliminate chemical buildup in the pipe and/or restrict water flow to the tub. Secure the hoses as required.

2.9 OPERATION CHECK

After all mounting, plumbing and electrical work is completed, select any desired wash cycle and run the machine through a complete wash cycle. Check for water leaks and verify proper operation.

During intermediate spin and final spin, the cylinder should turn in a counterclockwise direction when viewed from the front of the machine. If spin is clockwise, the T1 and T2 motor wires connecting to terminal T1 and T2 on the variable frequency drive should be swapped. Remove power to the machine before opening service panels and swapping wires.

2.10 MAXIMUM DISPLACEMENT SWITCH CHECK

WARNING: Do NOT bypass this switch to operate the washer.

After the washer is properly installed, the maximum displacement switch should be checked for functionality. The switch (black plunger) is located behind the front panel on the left side of the washer tub.

First check that the switch is fully pulled out, then start a wash cycle. Carefully push in the plunger on the switch. When the plunger is pushed in, the cycle should stop, the drain valve will open, and the display will show a message that the switch has been tripped.

To reset the washer, pull out the plunger on the switch and follow the instructions on the display to reset the washer.

Dexter Recommended Connections	Controller / Injector Signals
Detergent	1
Bleach	2
Starch	3
Sour/Softener	4
	5
	6
	7
	8
	9
	10



! WARNING

Always disconnect electrical power to the machine before performing any adjustments or service.

OPERATING INSTRUCTIONS

2.11 STARTING THE WASHER

2.11.1 Turn on power to the washer.

2.11.2 Load the laundry.

Place laundry into the cylinder and latch the door securely by pushing the door close and then turning the door handle counterclockwise. Be sure laundry does not get caught between the door gasket and tub front when closing the door. Maximum load is the dry weight capacity listed in the specification sheet. Do not exceed the listed capacity weight.

2.11.3 Select wash cycle.

Select the appropriate cycle for the type of load being washed. Use the "UP" and "DOWN" keys to change the cycle on the display to the desired cycle and press the enter button to select.

2.11.4 Add washing chemicals.

If not using a chemical injection system, add low sudsing powdered detergent into the "DETERGENT" compartment of the automatic dispenser on the top of the washer.

If liquid wash products are used in the "DETERGENT" compartment, they must be added at the beginning of the wash cycle.

If desired, add fabric softener to the "FABRIC SOFTENER" compartment. Use the amount of fabric softener as recommended by the manufacturer.

If the machine is set for pre-wash, washing products can be added to the round opening of the dispenser or put in with the clothes when loading the washing machine.

If bleach is desired, DO NOT place into dispenser until the ADD BLEACH message is displayed.

2.11.5 Start wash cycle.

Press enter to start the cycle. The display will show cycle information throughout the cycle. The door will lock and remain locked until the end of the cycle.

2.11.6 Pause wash cycle / End wash cycle

Press the red pause button to pause the cycle. Select Start to restart the cycle or select Cancel Cycle to end the wash cycle.

2.12 END OF CYCLE

A tone will sound (if programmed) and the display will indicate that the cycle has ended. The door can now be opened. Immediately remove contents of washer. Leave the door open when the machine is not in use.

2.13 EMERGENCY STOP / SAFETY DOOR LOCK

This machine is equipped with a safety door lock that locks the door when the cycle is started until the cycle is complete. The door lock prevents opening the door if the power is interrupted during the cycle.

The Emergency Stop button ends the cycle and allows the door to be opened after the Safety Door Lock releases. When the Emergency Stop button is pressed an alarm will sound (if programmed), an "Emergency Stop" message will be displayed, tumbler movement will begin to slow and water will begin draining from inside the washer. Though the machine may end movement quickly, it may take up to 15 seconds for the door to unlock. During that time the alarm will continue to sound. When the alarm stops, the door may be opened. Inspect the washer as needed and reset the emergency stop button by turning it clockwise. Reset the washer by selecting Cancel. The washer may be restarted by closing and latching the door and starting a new cycle.

If power is lost during a cycle the door will remain locked. The door lock can be manually released. Before doing so, check that the drum is not in motion and there is no water in the drum. To unlock the door, insert a small rod of a diameter less than .157" (4mm) firmly into the hole shown below and then turn the door handle clockwise to open.

2.14 VARIABLE FREQUENCY DRIVE INDICATORS

There are three small colored LEDs located on the upper region of the Variable Frequency Drive (VFD). They are labeled as "READY", "RUN", and "FAULT" and can be used for troubleshooting. The definitions of the LEDs are listed in the table below.



LED Status	Washer Condition
Steady Yellow	Tumbling
Blinking Yellow	Stop from Tumble
Steady Yellow	Ramp to Intermediate or Final Extract Spin
Steady Yellow	Spinning (Intermediate or Final)
Blinking Yellow	Stop from Spin (Intermediate or Final)
Steady Green	Idle Mode (No Cylinder Movement)
Steady Red	VFD fault
Blinking Red	VFD warning

Variable Frequency Drive Indicators

Notes

S-SERIES WASHERS PROGRAMMING WITH DEXTERLIVE



Our S-Series washers are simple and easy to program with DexterLive.com. This guide will provide an overview of some of the features DexterLive offers and how to create the cycles that fit your location's specific needs.

Set-Up an Account and Location

If you don't already have a DexterLive account, it is easy to register at DexterLive.com.

Once you have an account, you can create a new location and customize that location based on a specific application. Simply select on-premise laundry as your location type and the application type option will be available.

Tip: If you have multiple applications, you can provide a generic name (e.g., Motel) and use the same custom programs across multiple locations.

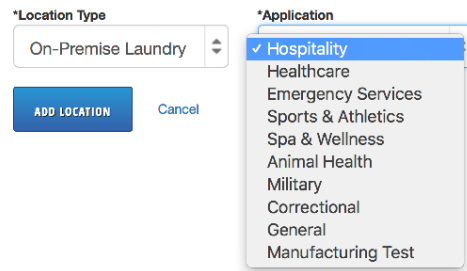

Add Equipment

Before programming cycles, you need to add equipment. Because functionality differs between model types, it is important to select the right model. You can name your machine, input the serial number, and add the DexterLive ID if you choose. However, this information is not required.

Tip: To create a generic program to be used in many locations, leave the serial number and DexterLive ID blank.

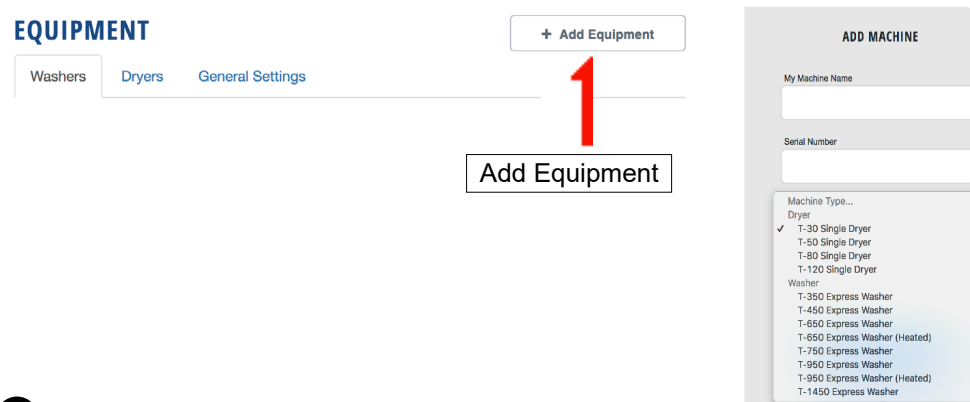

General Settings

General settings will set the global parameters for your location. These parameters will impact all washers and dryers added to that location.

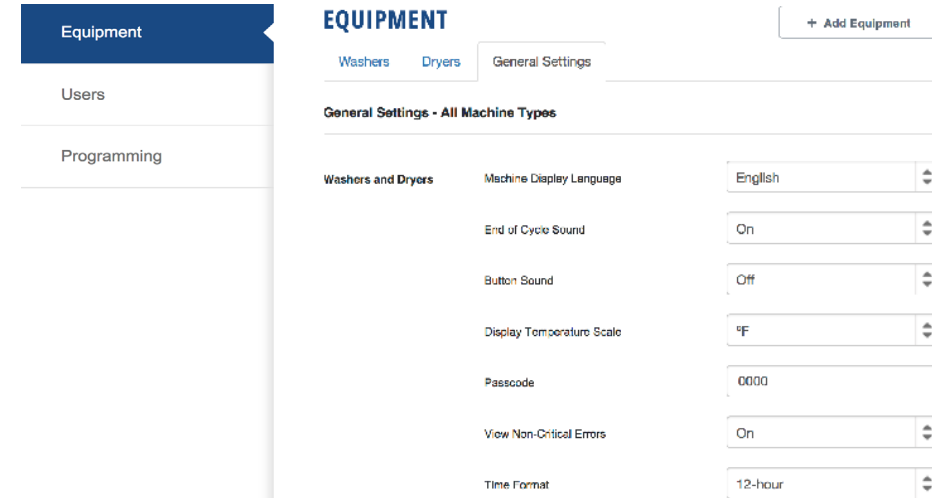

Setting	Options	Notes
Machine Display Language	Multiple	Changes the language of cycles, stages, and prompts that are displayed on the control. Individual cycles can still be set for different languages.
End of Cycle Sound	On / Off	Buzzer will sound when cycle is complete.
Button Sound	On / Off	Audible feedback when buttons are pressed.
Display Temperature	°F / °C	Choose between Fahrenheit or Celsius.
Passcode	0000 – 9999	Select a code for management screen access
View Non-Critical Errors	On / Off	Will display errors such as Slow Fill / Slow Drain during cycle. If OFF, these errors will still register in the cycle log, but will not be shown on the display.
Time Format	12 hr / 24 hr	Changes how time is displayed on the control.

Machine Settings

Most programming functions are available under the individual machine settings. Under this selection, you can review, edit, create, or delete cycles as well as select injection types and customize tumble speeds.



Cycles

The cycle page allows you to add, edit, copy, delete, or reorder cycles.

	CYCLE NAME	TOTAL TIME	MAX FILL TEMP	MAX TUMBLE MODE			
Cycle 1	White Sheets	27 min	Hct	Normal	☰	📄	🗑️
Cycle 2	Color Sheets	22 min	Warm	Normal	☰	📄	🗑️
Cycle 3	White Towels	28 min	Hct	Normal	☰	📄	🗑️
Cycle 4	Color Towels	23 min	Warm	Normal	☰	📄	🗑️
Cycle 5	Blankets	29 min	Warm	Normal	☰	📄	🗑️
Cycle 6	Delicates	23 min	Warm	Delicate	☰	📄	🗑️
Cycle 7	Rags & Mops	35 min	Hct	Normal	☰	📄	🗑️
Cycle 8	Uniforms	29 min	Hct	Normal	☰	📄	🗑️
Cycle 9	Stain Treatment	60 min	Hct	Normal	☰	📄	🗑️
Cycle 10	White Linens	33 min	Hct	Normal	☰	📄	🗑️
Cycle 11	Colored Linens	32 min	Hct	Normal	☰	📄	🗑️
Cycle 12	White Uniforms	36 min	Hct	Normal	☰	📄	🗑️

+ Add Cycles

Legend

	Edit Cycle	Select anywhere on the cycle description (cycle name, target temp, material, or target) to open the cycle details for editing.
☰	Reorder Cycle	Select and hold to move a cycle up or down in the listing. This will change the order it is displayed on the control.
📄	Copy Cycle	This will duplicate the cycle. Tip: It is easiest to edit an existing cycle instead of creating a new cycle. Copy the cycle that is closest to the cycle you want to create and edit that cycle. If a default cycle doesn't meet your needs, select "Add Cycle" and choose a default cycle from another application. You can always change the cycle name in the edit section.
🗑️	Delete Cycle	This will delete an existing cycle.
+ Add Cycles	Add Cycle	This will allow you to add a preset cycle from another industry or another location.

Cycle Settings

A cycle can be edited by clicking on the cycle name in the Cycles page. The name and language can be customized for that specific cycle. Changing the language for a cycle will change the status, stage names, and prompts displayed during that particular cycle.

Cycle 1 - White Sheets Settings

Cycle Name

Language

Tip: If a location has multi-lingual employees, the same cycle can be duplicated and programmed for different languages. For example, in a location with English and Spanish speaking employees, program White Sheets to the desired settings. Copy that cycle, set that cycle language to Spanish, and note the name change to Sabanas Blancas. This will allow all employees to read the necessary prompts and descriptions on the control.

Stages

A stage can also be considered a bath, such as prewash, wash, rinse, etc. Each cycle can consist of 20 unique stages. Within each stage, the following parameters can be selected.

Setting	Options	Options	Description
Fill	Bath Temperature	Hot Warm Cold No Fill	
	Auxiliary Temperature (Heated Models Only)	No Heat 100F (38C) – 195F (91C)	Heated models only. Temperature is programmable in 5 °F / 3° C increments.
	Water Level	Low High	These settings can be controlled by the electronic pressure sensor.
Soap / Chemicals	Injection Type 1 – 3	None Detergent Flush Softener Flush Chemical 1-10	Three unique soap options are available for each stage. See optional settings for setting chemical injection details.
	Injection Delay	0 – 150 seconds	If Delay Fill is ON this is the time from when the low water level is met. If Delay Fill is OFF this represents the time from start of the stage to when chemical injection begins.
	Injection Duration	1 – 240 seconds	The amount of time chemicals will be injected.

Bath	Soak Time	0 – 60 minutes	Time from when fill is complete to when agitation begins.
	Agitation Time	0 – 30 minutes	Time load will tumble.
	Agitation Type	Normal Delicate Custom 1-3	Aggressiveness of the tumble action. Tip: For wet clean or super-delicate applications, create your own custom agitation type in the optional settings.
Drain	Drain Method	Standard None	Tip: Select None for a soak longer than 60 minutes
Spin	Spin Time	0-30 minutes	Amount of time in spin mode.
	Spin Speed	60 – 200G	Spin time must be selected to set spin speed. Speed is programmable in 20G increments.

Continue adding or editing stages as appropriate to create the specific cycle you want. Remember, you have the ability to customize all 20 stages, so get creative and gain Total Control over your laundry experience.

Tip: See example below illustrating how stages can be customized to create a specialty cycle, such as an extended soak.

Example - Extended Soak:

Parameter	Stage 1: Prewash	Stage 2: Soak	Stage 3: Soak	Stage 4: Soak / Wash	Stage 5: Rinse	Stage 6: Final Rinse
Temperature	Cold	Cold	NA	NA	Cold	Cold
Water Level	High	High	High	High	High	High
Soap	None	Chemical 1, 2 &3	None	None	Chemical 4	Chemical 5
Soak Time	0 mins	60 mins	60 mins	15 mins	0 mins	0 mins
Agitate Time	5 mins	0 mins	0 mins	30 mins	15 mins	15 mins
Agitation Type	Normal	NA	NA	Normal	Normal	Normal
Drain Method	Standard	None	None	Standard	Standard	Standard
Spin Time	NA	NA	NA	2 mins	5 mins	5 mins
Spin Speed	NA	NA	NA	200G	100 G	200G

Optional Settings

These settings will only apply to that specific model type. For instance, optional settings for the T-950 will not apply to a T-650. These will need to be set individually by model.



Cycles **Optional Settings**

Custom Agitation

DexterLive has the ability to create 3 custom agitation types. These custom agitations will enable you to create cycles such as a wet clean cycle with “rocking” methods versus a true tumble agitation.

Cycles **Optional Settings**

Settings for All Cycles on the T-950 Express Washer. These settings will be applied to only this model type.

Agitation

		Tumble Speed	Tumble Time	Dwell Time
Custom 1	Custom 1	Normal	15 seconds	0 seconds
Custom 2	Custom 2	Normal	15 seconds	0 seconds
Custom 3	Custom 3	Normal	15 seconds	0 seconds

Settings	Options	Notes
Tumble Speed	Normal (G / RPM)	
	T-350 0.9 / 55 0.6 / 47	
	T-450 0.9 / 50 0.6 / 41	
	T-650 0.9 / 50 0.6 / 41	
	T-750 0.9 / 43 0.6 / 36	
	T-950 0.9 / 43 0.6 / 33	
	T-1450 0.9 / 39 0.6 / 32	
Tumble Time	1 – 60 seconds	Controls how long the tumbler agitates before dwell. Tip: By selecting a short tumble time, you can prevent the tumbler from making a full rotation, creating a “sloshing” action versus a tumble action.
Dwell Time	0 – 60 seconds	Controls the length of pause between tumbler action. Tip: By selecting a long dwell time, you allow items to “settle” before restarting the tumbler action.

Tip: See example below for how a custom agitation can be used to create a wet clean cycle.

Example: Wet Clean

Agitation

Custom 1 Wet Clean Delicate 6 seconds 10 seconds

Tumble Speed Tumble Time Dwell Time

Parameter	Stage 1: Prewash	Stage 2: Soak	Stage 3: Soak	Stage 4: Soak / Wash	Stage 5: Rinse	Stage 6: Final Rinse
Temperature	Cold	Cold	NA	NA	Cold	Cold
Water Level	Low	High	High	High	High	High
Soap	None	Chemical 1	None	None	Chemical 5	Chemical 6
Soak Time	0 mins	10 mins	10 mins	10 mins	5 mins	5 mins
Agitate Time	2 mins	2 mins	2 mins	2 mins	2 mins	2 mins
Agitation Type	Wet Clean	Wet Clean	Wet Clean	Wet Clean	Wet Clean	Wet Clean
Drain Method	Standard	None	None	Standard	Standard	Standard
Spin Time	0 mins	NA	NA	0 mins	2 mins	2 mins
Spin Speed	NA	NA	NA	NA	60 G	100 G

Injection Source Names

Name specific injection sources to clearly show which chemical is being used in which stage or cycle.

Delay Fill

With Delay Fill on, the stage does not begin decrementing time until the water level is met. This ensures the load soaks or agitates the target time, even in cases of low water pressure and slow fills. The default settings have Delay Fill turned ON.

Delay Spin

Delay Spin can be set to OFF or up to 150 seconds. Delay Spin can be used in slow drain situations to reduce nuisance Slow Drain error codes. The default settings have Delay Spin turned OFF.

Programming

Once all cycles are set, the programming file (called userconfig.xml) can be downloaded following the instructions on the programming tab DexterLive.com.

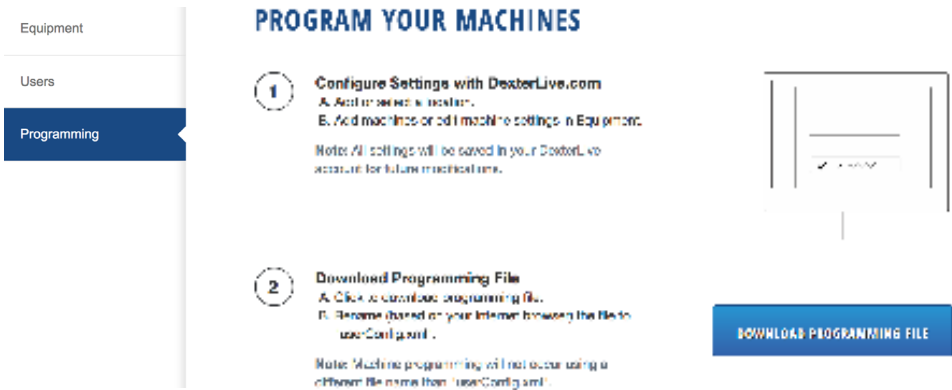

At the machine, you can enter management view by pressing up on the idle screen.

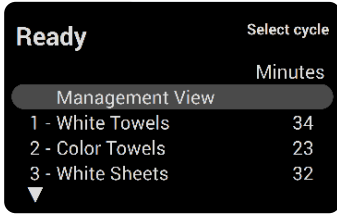

Simply insert the USB, scroll to Import User Data, and begin using your customized washer cycles.

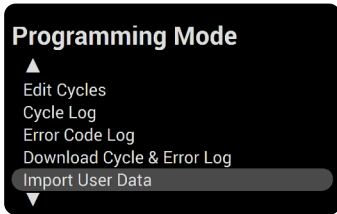

2.11.5 MAXIMUM SPIN SPEED ADJUSTMENT (All washers except T-950)

If desired, the washer can be adjusted to limit the maximum extract spin speed for all wash cycles.

To make this adjustment, a jumper wire must either be installed or removed on the Variable Frequency Drive (VFD), depending on the washer model and desired speed. This Dexter jumper part number 8220-057-036 (qty 1) is factory supplied on terminal points "10V" and "RC". Remove this jumper connections if necessary. Refer to figure below for the approximate location of the control terminations on the Variable Frequency Drive (VFD) and for appropriate jumper connection points indicated with an "X" for the desired maximum spin speed setting. If no adjustment to the default spin speed is desired, do not remove or add any wires on VFD.

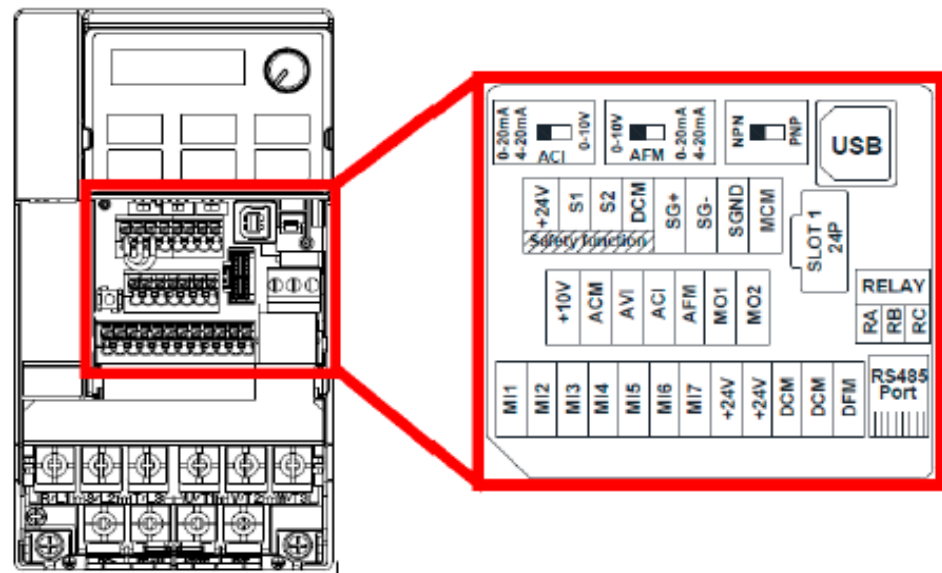

Control Terminations on Variable Frequency Drive

V Series Washer Model	Max Spin Speed	Jumper Terminal Locations on Variable Frequency Drive (VFD)														
		MI1	MI2	MI3	MI4	MI5	MI6	DCM (Left)	DCM (Right)	24V	ACM	AVI	ACI	10V	M01	
T-300, T-400, T-600, T-900, T-1200	60 G													X		X
	80 G				X			X								
	100 G	Default Setting (No Jumper Required)														
T-350, T-450, T-750	60 G													X		X
	100 G				X			X								
	140 G					X		X								
	200 G	Default Setting (No Jumper Required)														
T-650, T-1450	100 G													X		X
	140 G	REMOVE Brown Jumper Between MI5/M01														
	200 G	Default Setting (No Jumper Required)														

Spin Speed Adjustment Jumper Locations

MAXIMUM SPIN SPEED ADJUSTMENT (T-950 Only)

The variable frequency drive allows for varying acceleration during Final Spin on T-950 models. It is important to utilize a decreased acceleration rate when the application power is low. This acceleration rate is determined by a white wire jumper installed on the drive terminal block from +10V to AVI.

Remove the wire jumper when input power is between 208 and 219 volts. Keep the jumper installed when input power is between 220 and 240 volts. Reference the drawing below for the jumper location.

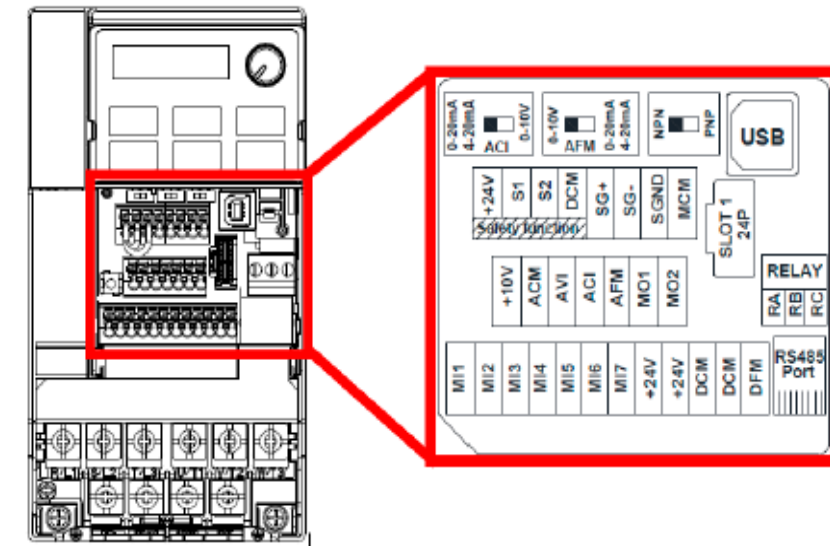

Control Terminations on Variable Frequency Drive

V Series Washer Model	Input Voltage	Max Spin Speed	Jumper Terminal Locations on Variable Frequency Drive (VFD)												
			MI1	MI2	MI3	MI4	MI5	MI6	DCM (Left)	DCM (Right)	24V	ACM	AVI	ACI	10V
T-950	240V	140 G	REMOVE Brown Jumper Between MI5/M01												
		200G												X	
	208V	140 G	REMOVE Brown Jumper Between MI5/M01												
		200G	No Jumper required												

T-950 Spin Speed Adjustment Jumper Locations

Common Troubleshooting Solutions

Symptom	Probable Cause	Suggested Remedy
Machine does not start	Power Supply	Check these areas: Circuit breakers, Voltage, Power leads, Power connections. Is front display LED display lit?
	Door Switch	Check for continuity through door switch when door is closed. If no continuity, adjust or replace door switch.
	Control Breaker or Fuse	Check the 1.5 amp and 2.0 amp fuses (60 hz models) or circuit breaker (50 hz models) for continuity. If no continuity, replace fuse or breaker.
	Control Transformer	Check voltage output from control transformer for 24 VAC and 120VAC (50 hz models have 24 VAC only). If voltage is incorrect, check for proper transformer tap connection or replace transformer.
	Check PCB board	Check all wire connections for sure contacts.
	Check wiring between PCB and VFD	Check data cable phone type connectors unplug and VFD and replug with power removed.
Door does not lock	Check Door Lock Mechanism	Check that 120 VAC power (for 60 hz) or 24 VAC power (for 50 hz) is at door lock motor after start button is pressed.
	Check display for fault code	Follow tests described in fault code section.
	Door locking mechanism	Check to ensure that mechanism is receiving 120VAC for 60 Hz. models (or 24VAC for 50 Hz. models) from main relay PCB. If it is receiving power but not functioning, then replace mechanism.
Door will not open	Door Switch	Check for continuity through door latch switch when door closed. If no continuity, adjust or replace door switch.
	Door locking mechanism	Check that door lock mechanism is not stuck closed. If stuck, replace.
No hot water in detergent dispenser	Water Valve Coil	Check coil continuity at terminals and replace if no continuity. 120 VAC power (60Hz) only on for 20 second in wash bath. (24 VAC for 50 Hz models)
	Water Inlet	Check water inlet screens for blockage and clean screens if necessary.
	Water	Check to insure that water is turned on and operating.
	Wire Harness	Check wire harness to valve.

Symptom	Probable Cause	Suggested Remedy
Hot water does not enter tub in wash	Water Valve Coil	Check coil continuity at terminals and replace if no continuity. Check for 120 VAC power (60 Hz) from main relay PCB. (24 VAC for 50 Hz models)
	Water Inlet	Check water inlet screens for blockage and clean if necessary.
	Water	Check to ensure that water is turned on and operating.
	Check Voltage	If appropriate voltage is not present at the valve, refer to the wiring diagram for your specific washer model. Check for voltage at the P4 Connector on the Relay PCB. Check for LED indication that the appropriate relay is activated.
No cold water to tub in wash	Pressure Switch	Check the green 1V, 1.5V, or 2V indicator LEDs on the pressure switch. Depending on the size and water fill level of the machine, these LEDs will turn on as the water level increases. If water level is empty, no LEDs should be on.
	Water Valve Coil	Check coil continuity at terminals and replace if no continuity.
	Water Inlet Screens	Check water inlet screens for blockage and clean if necessary.
	Water	Check to ensure that water is turned on and operating.
Water comes in but level does not rise	Check Voltage	If appropriate voltage is not present at the valve, refer to the wiring diagram for your specific washer model. Check for voltage at the P4 Connector on the Relay PCB. Check for LED indication that the appropriate relay is activated.
	Drain Valve (open)	Check these areas: <ul style="list-style-type: none"> • Drain valve blockage • Drain valve motor and gear train. If power but drain valve does not close, replace valve. • Power to the drain valve. If no power to drain valve, check circuit for power.
	Pressure Switch	Check the green 1V, 1.5V, or 2V indicator LEDs on the pressure switch. Depending on the size and water fill level of the machine, these LEDs will turn on as the water level increases. If water level is empty, no LEDs should be on.
Water does not flush softener compartment.	Check Voltage	If appropriate voltage is not present at the valve, refer to the wiring diagram for your specific washer model. Check for voltage at the P4 Connector on the Relay PCB. Check for LED indication that the appropriate relay is activated.
	Water Valve Coil	Check coil continuity at terminals and replace if no continuity.
	Water Inlet Screens	Check water inlet screens for blockage and clean if necessary.
Water does not flush softener compartment.	Water	Check to ensure that water is turned on and operating.
	Pressure Switch	Check the green 1V, 1.5V, or 2V indicator LEDs on the pressure switch. Depending on the size and water fill level of the machine, these LEDs will turn on as the water level increases. If water level is empty, no LEDs should be on.
Water level too high	Pressure Switch	Check the green 1V, 1.5V, or 2V indicator LEDs on the pressure switch. Depending on the size and water fill level of the machine, these LEDs will turn on as the water level increases. If water level is empty, no LEDs should be on.
Water drains slowly	Drain System	Check hoses and drain valve for blockage. Check if inadequate size. If necessary, check building drains for blockage.

Common Troubleshooting Solutions

Symptom	Probable Cause	Suggested Remedy
Machine does not turn	VFD	Review indicator lights displayed on VFD. See VFD indicator section for more info. If no display, turn power off to machine at breaker for 2 minutes and turn power back on to reset. If still no display, replace VFD.
Machine tumbles in one direction	VFD	Review indicator lights displayed on VFD. See VFD indicator section for more info.
		Inspect yellow enable wires from main relay PCB and at VFD.
Excessive vibration	Flooring	Check the strength of flooring or mounting base (if used).
	Drive Belt	Worn drive belt can cause vibration and noise.
	Out Of Balance Circuit	Check for an open circuit in the wiring between the VFD and the J8 connector on the main control board.
	Suspension	Check the springs and dampers for wear.
Machine does not spin	Pressure Switch	Check the green 1V, 1.5V, or 2V indicator LEDs on the pressure switch. Depending on the size and water fill level of the machine, these LEDs will turn on as the water level increases. If water level is empty, no LEDs should be on.
Machine starts and does not operate	VFD	Check for Error codes- Refer to individual Error code descriptions.
Machine does not stop	Main PCB	Main PCB controls time cycle at end of cycle
	Braking Resistors	Check braking resistors for continuity. Verify ohms resistance.
Water leakage around loading door	Door Adjustment	Door may need adjustment due to abuse or wear. Check tightness around perimeter using a dollar bill. Adjust left to right tightness by shims at door lock or hinge side. It is important to center gasket to tub opening before tightening door to hinge bolts. Chalk may be used on tub front to show point of contact with tub. If gasket is deformed, worn, or damaged, replace. Refer to parts section for door gasket expander kit.

Washer Troubleshooting

WASHER ERROR MESSAGES

The O-Series washer control reacts to various abnormal conditions by displaying an Error message. These messages usually contain the "Error" text, and then a general description of the message. Below is a listing of Error messages separated by each potential displayed message in bold face. Each is followed by:

- Condition that creates the displayed message on the control
- Action that the control takes responding to the condition
- Exit is the method the user (or the control) should use to bring the machine back to normal operation.

The actual displayed message on the control may contain the general description listed below and additional details (such as number or additional text). However, the condition, action or exit qualities of the error message should be the same for all variations.

OPERATION IN PROGRESS	
Condition	This error occurs when the user is attempting to start a machine operation while another operation is ending.
Action	When detected, the control does not respond to user input on the buttons. There is no delay in the action once the criteria are met. The control will finish the current operation while displaying "OPERATION IN PROGRESS". Once the operation is complete, the error will no longer be displayed and the control will respond to user input normally.
Exit	The error will be reset automatically once the current operation is complete.

POWER LOSS	
Condition	This error occurs when the Main Control Board detects a total loss of 24VAC power.
Action	When detected, the control turns off the motor and all relays. There is no delay in the action once the criteria are met.
Exit	The machine will not start and the Error Code will continue to be displayed until the condition is no longer present. Once the condition is removed, the machine still will not start and the Error Code will continue to be displayed until the prompt is followed to Reset the Error and return the machine to Idle Mode.

BROWN OUT	
Condition	This error occurs when the Main Control Board detects less than 21VAC at the 24VAC input.
Action	When detected, the control turns off the motor and all relays. There is no delay in the action once the criteria are met.
Exit	The machine will not start and the Error Code will continue to be displayed until the condition is no longer present. Once the condition is removed, the machine still will not start and the Error Code will continue to be displayed until the prompt is followed to Reset the Error and return the machine to Idle Mode.

TEMP SENSOR SHORT	
Condition	This error occurs when the control detects a short circuit from the temperature sensor.
Action	When detected, the control turns off the motor and all relays. There is no delay in the action once the criteria are met.
Exit	The machine will not start and the Error Code will continue to be displayed until the condition is no longer present. Once the condition is removed, the machine still will not start and the Error Code will continue to be displayed until the prompt is followed to Reset the Error and return the machine to Idle Mode.
Note	This error code is disabled if the washer model does not have a temperature sensor

TEMP SENSOR OPEN	
Condition	This error occurs when the control detects an open circuit from the temperature sensor.
Action	When detected, the control turns off the motor and all relays. There is no delay in the action once the criteria are met.
Exit	The machine will not start and the Error Code will continue to be displayed until the condition is no longer present. Once the condition is removed, the machine still will not start and the Error Code will continue to be displayed until the prompt is followed to Reset the Error and return the machine to Idle Mode.
Note	This error code is disabled if the washer model does not have a temperature sensor

NO HEAT RISE	
Condition	This error occurs when the control detects that the temperature is not increasing.
Action	When detected there is a delay of 15 minutes before the error is active. Once active, the control will display the "NO HEAT RISE" prompt, alternating with the normal Cycle Progress screen at a rate of 5 seconds on, 5 seconds off. The heating relay will also be turned off. Otherwise the cycle will continue normally.
Exit	The Error Code will continue to be displayed until the in-progress cycle is stopped and the control is returned to Idle Mode. It will then reset automatically.
Note	This error code is disabled if the washer model does not have an Auxiliary Heating option

HEAT RISE OUT OF RANGE	
Condition	This error occurs when the control detects that the operating temperature is greater than 220 degrees F (or 104 degrees C).
Action	When detected, the control will display the "HEAT RISE OUT OF RANGE" prompt, alternating with the normal Cycle Progress screen at a rate of 5 seconds on, 5 seconds off. The heating relay will also be turned off. Otherwise the cycle will continue normally. There is no delay in the action once the criteria are met.
Exit	The Error Code will continue to be displayed until the in-progress cycle is stopped and the control is returned to Idle Mode. It will then reset automatically.
Note	This error code is disabled if the washer model does not have an Auxiliary Heating option

NO PROX SENSOR OUTPUT	
Condition	This error occurs when the machine control does not detect output from the proximity sensor(s) when the cylinder has been commanded to turn.
Action	When detected, there is a short delay before the error is active. When active, the control turns off the motor and all relays.
Exit	The machine will not start and the Error Code will continue to be displayed until the prompt is followed to Reset the Error Code and return the Machine to Idle Mode.

PROX SENSOR OUT OF RANGE	
Condition	This error occurs when the machine control sees output from the proximity sensor(s) that does not fall in the acceptable range for the particular washer or dryer model running at normal speeds. It also occurs when the machine control sees output from the proximity sensor that implies the tumbler is still turning when the control has commanded it to Stop.
Action	When detected, there is a short delay before the error is active. When active, the control turns off the motor and all relays.
Exit	The machine will not start and the Error Code will continue to be displayed until the prompt is followed to Reset the Error Code and return the Machine to Idle Mode.

CONTROL FIRMWARE XX	
Condition	This error occurs when the Main Control Board cannot command the input and outputs of the control system as required by the cycle programming.
Action	When detected, the control turns off the motor and all relays. There is no delay in the action once the criteria are met.
Exit	The machine will not start and the Error Code will continue to be displayed until the prompt is followed to Reset the Error Code and return the Machine to Idle Mode. If the prompt to Reset is not available, power must be cycled to the machine to reset the error.

CONTROL COMMUNICATION

Condition	This error occurs when the Main Control Board receives an unexpected command for the input and outputs of the control system as required by the cycle programming.
Action	When detected, the control turns off the motor and all relays. There is no delay in the action once the criteria are met.
Exit	The machine will not start and the Error Code will continue to be displayed until the prompt is followed to Reset the Error Code and return the Machine to Idle Mode. If the prompt to Reset is not available, power must be cycled to the machine to reset the error.

GRAPHICS SOFTWARE

Condition	This error occurs when the Graphics Board cannot command the Main Control board as required by the cycle programming.
Action	When detected, the control turns off the motor and all relays. There is no delay in the action once the criteria are met.
Exit	The machine will not start and the Error Code will continue to be displayed until the prompt is followed to Reset the Error Code and return the Machine to Idle Mode. If the prompt to Reset is not available, power must be cycled to the machine to reset the error.

GRAPHICS SOFTWARE INTERNAL

Condition	This error occurs when the Graphics Board sends a faulty command to the Main Control board.
Action	When detected, the control turns off the motor and all relays. There is no delay in the action once the criteria are met.
Exit	The machine will not start and the Error Code will continue to be displayed until the prompt is followed to Reset the Error Code and return the Machine to Idle Mode. If the prompt to Reset is not available, power must be cycled to the machine to reset the error.

MODEL JUMPER MISSING

Condition	This error occurs when there is no connection to Ground (Pin 7) on the Model Jumper Header.
Action	When detected, the control turns off the motor and all relays. There is no delay in the action once the criteria are met. The machine control checks for this condition when power is cycled and before starting every machine cycle.
Exit	The machine will not start and the Error Code will continue to be displayed until the condition no longer exists and the prompt is followed to Reset the Error Code and return the Machine to Idle Mode.

MODEL JUMPER CHANGED

Condition	This error occurs when the jumper connections to Ground (Pin 7) on the Model Jumper Header have changed since the last control check.
Action	When detected, the control turns off the motor and all relays. There is no delay in the action once the criteria are met. The machine control checks for this condition when power is cycled and before starting every machine cycle.
Exit	The machine will not start and the Error Code will continue to be displayed until the condition no longer exists and the prompt is followed to Reset the Error Code and return the Machine to Idle Mode.

MODEL JUMPER/ DRIVE SIZE MISMATCH

Condition	This error occurs when the jumper connections to Ground (Pin 7) on the Model Jumper Header do not match the VFD size code.
Action	When detected, the control turns off the motor and the heating relay. There is no delay in the action once the criteria are met. The machine control checks for this condition when power is cycled.
Exit	The machine will not start and the Error Code will continue to be displayed until the condition no longer exists and the prompt is followed to Reset the Error Code and return the Machine to Idle Mode.

MODEL JUMPER/ DRIVE PARAMETER

Condition	This error occurs when the jumper connections to Ground (Pin 7) on the Model Jumper Header do not match the VFD parameters being used.
Action	When detected, the control turns off the motor and the heating relay. There is no delay in the action once the criteria are met. The machine control checks for this condition when power is cycled.
Exit	The machine will not start and the Error Code will continue to be displayed until the condition no longer exists and the prompt is followed to Reset the Error Code and return the Machine to Idle Mode.

NON-DEXTER DRIVE

Condition	This error occurs when a non-Dexter VFD is installed in the machine.
Action	When detected, the control turns off the motor and all relays. There is no delay in the action once the criteria are met. The machine control checks for this condition when power is cycled and before starting every machine cycle.
Exit	The machine will not start and the Error Code will continue to be displayed until the condition no longer exists and the prompt is followed to Reset the Error Code and return the Machine to Idle Mode.

DRIVE OVERCURRENT

Condition	This error occurs when the control receives a message that the drive has experienced an over current condition.
Action	When detected, the control turns off the motor and all relays. There is no delay in the action once the criteria are met.
Exit	The machine will not start and the Error Code will continue to be displayed until the condition no longer exists and the prompt is followed to Reset the Error Code and return the Machine to Idle Mode.

DRIVE OVERVOLTAGE

Condition	This error occurs when the control receives a message that the drive has experienced an over voltage condition.
Action	When detected, the control turns off the motor and all relays. There is no delay in the action once the criteria are met.
Exit	The machine will not start and the Error Code will continue to be displayed until the condition no longer exists and the prompt is followed to Reset the Error Code and return the Machine to Idle Mode.

DRIVE OVERHEAT	
Condition	This error occurs when the control receives a message that the drive has experienced an over heat condition.
Action	When detected, the control turns off the motor and all relays. There is no delay in the action once the criteria are met.
Exit	The machine will not start and the Error Code will continue to be displayed until the condition no longer exists and the prompt is followed to Reset the Error Code and return the Machine to Idle Mode.

DRIVE OVERHEAT	
Condition	This error occurs when the control receives a message that the drive has experienced an over heat condition.
Action	When detected, the control turns off the motor and all relays. There is no delay in the action once the criteria are met.
Exit	The machine will not start and the Error Code will continue to be displayed until the condition no longer exists and the prompt is followed to Reset the Error Code and return the Machine to Idle Mode.

DRIVE OVERLOAD	
Condition	This error occurs when the control receives a message that the drive has experienced an overload condition.
Action	When detected, the control turns off the motor and all relays. There is no delay in the action once the criteria are met.
Exit	The machine will not start and the Error Code will continue to be displayed until the condition no longer exists and the prompt is followed to Reset the Error Code and return the Machine to Idle Mode.

DRIVE GROUND FAULT	
Condition	This error occurs when the control receives a message that the drive has experienced a ground fault condition.
Action	When detected, the control turns off the motor and all relays. There is no delay in the action once the criteria are met.
Exit	The machine will not start and the Error Code will continue to be displayed until the condition no longer exists and the prompt is followed to Reset the Error Code and return the Machine to Idle Mode.

DRIVE LOW VOLTAGE	
Condition	This error occurs when the control receives a message that the drive has experienced a low voltage condition.
Action	When detected, the control turns off the motor and all relays. There is no delay in the action once the criteria are met.
Exit	The machine will not start and the Error Code will continue to be displayed until the condition no longer exists and the prompt is followed to Reset the Error Code and return the Machine to Idle Mode.

DRIVE INTERNAL	
Condition	This error occurs when the control receives a message that the drive has experienced an internal error.
Action	When detected, the control turns off the motor and all relays. There is no delay in the action once the criteria are met.
Exit	The machine will not start and the Error Code will continue to be displayed until the condition no longer exists and the prompt is followed to Reset the Error Code and return the Machine to Idle Mode.

DRIVE EXCEPTION	
Condition	This error occurs when the control receives a message that the drive has logged an exception code.
Action	When detected, the control turns off the motor and all relays. There is no delay in the action once the criteria are met.
Exit	The machine will not start and the Error Code will continue to be displayed until the condition no longer exists and the prompt is followed to Reset the Error Code and return the Machine to Idle Mode.

DRIVE COMMUNICATION	
Condition	This error occurs the control cannot communicate with the VFD.
Action	When detected, the control turns off the motor and all relays. There is no delay in the action once the criteria are met.
Exit	The machine will not start and the Error Code will continue to be displayed until the condition no longer exists and the prompt is followed to Reset the Error Code and return the Machine to Idle Mode.

DRIVE ENABLE	
Condition	This error occurs when the control sees a message that the VFD Enable circuit is not closed.
Action	When detected, the control turns off the motor and all relays. There is no delay in the action once the criteria are met.
Exit	The machine will not start and the Error Code will continue to be displayed until the condition no longer exists and the prompt is followed to Reset the Error Code and return the Machine to Idle Mode.

DOOR SHUT, NOT LOCKED	
Condition	This error occurs when the Door Locked signal is not received within 1 second after the start of the cycle.
Action	When detected, the control turns off the motor and all relays. There is no delay in the action once the criteria are met.
Exit	The machine will not start, and the Error Code will continue to be displayed until the prompt is followed to Reset the Error and return the machine to Idle mode.

SLOW SPIN	
Condition	This error occurs when the motor does not reach a target frequency while accelerating, within a specified time.
Action	When detected, the control turns off the motor and machine motion stops.
Exit	The machine will not start, and the Error Code will continue to be displayed until the prompt is followed to Reset the Error and return the machine to Idle mode.

SPIN TIME	
Condition	This error occurs when the motor does not reach a target frequency while decelerating, within a specified time.
Action	When detected, the control turns off the motor and machine motion stops.
Exit	The machine will not start, and the Error Code will continue to be displayed until the prompt is followed to Reset the Error and return the machine to Idle mode.

SLOW FILL	
Condition	This error occurs when the programmed water level is not reached within 7 minutes.
Action	When detected at 7 minutes into the stage, the control will display the "SLOW FILL ERROR" prompt, alternating with the normal Cycle Progress screen at a rate of 5 seconds on, 5 seconds off. Otherwise the cycle will continue normally. However, if the water level is still not met at 15 minutes into the stage, the cycle will end with the motor turned off and all relays turned off The machine will not start and the Error Code will continue to be displayed until the condition no longer exists and the prompt is followed to Reset the Error Code and return the Machine to Idle Mode.
Exit	The Error Code will continue to be displayed until the in-progress cycle is stopped and the control is returned to Idle Mode. It will then reset automatically.

SLOW DRAIN	
Condition	This error occurs when an empty water level is not reached within 5 minutes.
Action	When detected at 5 minutes from the beginning of the drain operation, the prompt "SLOW DRAIN ERROR" is displayed. The washing cycle continues, but the spin portion of the cycle will not occur. It is replaced by continued tumble until the cycle time is expired. If low water level is detected during spin, the control turns off the motor and all relays with no delay in action.
Exit	The machine will not start and the Error Code will continue to be displayed until the condition no longer exists and the prompt is followed to Reset the Error Code and return the Machine to Idle Mode.

EXCESSIVE VIBRATION	
Condition	This error occurs when excessive vibration is detected or the out of balance circuit from the VFD to the main control board is compromised.
Action	When detected, the control turns off the motor and all relays. There is no delay in the action once the criteria are met.
Exit	The machine will not start and the Error Code will continue to be displayed until the condition no longer exists and the prompt is followed to Reset the Error Code in the General Settings section and return the Machine to Idle Mode. The maximum displacement switch may also need to be reset (See in Service Procedures)

PRESSURE OUT OF RANGE HIGH	
Condition	This error occurs when the pressure sensing voltage is higher than expected.
Action	When detected, the control turns off the motor and all relays. There is no delay in the action once the criteria are met.
Exit	The machine will not start and the Error Code will continue to be displayed until the condition no longer exists and the prompt is followed to Reset the Error Code and return the Machine to Idle Mode.

PRESSURE OUT OF RANGE LOW	
Condition	This error occurs when the pressure sensing voltage is lower than expected.
Action	When detected, the control turns off the motor and all relays. There is no delay in the action once the criteria are met.
Exit	The machine will not start and the Error Code will continue to be displayed until the condition no longer exists and the prompt is followed to Reset the Error Code and return the Machine to Idle Mode.

OUT OF BALANCE LOAD	
Condition	This error occurs when the load in the machine exceeds the out of balance conditions for achieving spin speeds.
Action	If detected, the machine will attempt to redistribute the load by tumbling. During any intermediate spin, the machine will attempt to redistribute the load 1 time before the advancing to the next stage. During final spin, the machine will attempt up to 3 redistributions before the final de-clumping occurs.
Exit	No user input is required to clear this error condition.

OUT OF SERVICE	
Condition	This error occurs when the user has designated that the machine control should be made inoperable.
Action	When detected, the control turns off the motor and all relays. There is no delay in the action once the criteria are met.
Exit	The machine will not start, and the Error Code will continue to be displayed the user changes the Out of Service state.

Note: Whenever power is turned off to the washer, it must remain off for one minute. The washer will not operate properly if this is not done.

6 TRANSIENT VOLTAGE SURGE SUPPRESSORS

IMPORTANT

Like most electrical equipment your new machine can be damaged or have its life shortened by voltage surges due to lightning strikes which are not covered by factory warranty. Local power distribution problems also can be detrimental to the life of electrical components. We recommend the installation of transient voltage surge suppressors for your new equipment. These devices may be placed at the power supply panel for the complete installation and don't require an individual device for each machine.

These surge protectors help to protect equipment from large spikes and also from small ongoing spikes in the power that occur on a day to day basis. These smaller surges can shorten overall life of electrical components of all types and cause their failure at a later date. Although they can't protect against all events, these protective devices have a good reputation for significantly lengthening the useful life of electronic components.

Electronic components are helped to have a longer useful life when they are supplied with the clean stable electrical power they like.

We are including the following names and website links of a few suppliers of these devices for those who don't currently have a source.

MANUFACTURER	LINK
MCG Surge Protection	mcgsurge.com
Eaton Corporation	eaton.com/us/en-us
Schneider Electric	se.com/us/en
Asco Power Technologies	ascopower.com/us/en
Emerson Electric Co.	emerson.com/en-us

7 SERVICE AND PARTS

The following parts are provided with each machine for use in installation.

Dexter Part Number	Description	Quantity
9990-027-011	Hose, Water Supply	2
9990-027-013	Hose, Water Supply (Large)	2
8641-242-000	Washer, Inlet Hose	4
9565-003-001	Strainer, Inlet Hose	4

Contact distributor or Dexter Laundry, Inc. if a steel-mounting base is required.

For service and parts information, contact your local Dexter agent. To find your local Dexter agent, use the Distributor Locator at the website shown below. If a Dexter agent is not available, contact Dexter Laundry, Inc. directly as listed below:

Phone: 1-800-524-2954

Website: www.dexter.com

Drive Motor Inverter Type Motor-Winding Resistance Chart

S-975 S-Series Express Washer

Motor	Winding	Wire #	Resistance	
			Minimum	Maximum
S-975 1PH or 3PH 60Hz Main (wash & spin)		T1 & T2	0.47	0.47
Dexter #9376-326-001		T2 & T3	0.47	0.47
		T1 & T3	0.47	0.47

NOTE: Resistance values are measured at the stator. Values at the end of the motor wiring harness may be slightly higher.

Top Panel Removal Top Soap Dish

- Step 1: Remove 4 screws that hold detergent dispenser to top panel.
- Step 2: Unlock top panel lock.
- Step 3: Raise top panel, slide to the rear to release from back clips and lift off.

Front Panel Removal

- Step 1: Remove 2 screws between front panel top and front (located behind control panel).
- Step 2: Remove the two or four screws in the middle of the front panel.
- Step 3: Pull panel out at the bottom to about a 45 degree angle to detach the top lip and remove.

Back Panel Removal

- Step 1: Remove all screws holding back panel in position except the bottom row.
- Step 2: The bottom row of screws are slotted and only need to be loosened and to lift off panel.

NOTE: The back panel is not only a safety requirement but also contributes to the rigidity of the cabinet.

Drain Valve Access

For access to drain valve, remove lower service panel. The drain valve is a ball type and is powered closed by the drain valve motor. It is mounted under the washer tub in the center. It is spring loaded open. If power is interrupted to the washer, the motor releases the sealing ball, allowing the drive spring to open the valve. With the valve open, all water in the washer will drain out.

Drain Valve Cleaning

- Step 1: Loosen the clamp on the tub hose at the drain valve end and remove the hose from the drain valve.
- Step 2: Loosen the drain hose clamp on the back of the drain valve. Remove two drain valve mounting racket screws from the frame of the washer.
- Step 3: Disconnect red/white & white/red wire connection at clear connector.
- Step 4: Remove the drain valve and bracket assembly. Unplug the wiring after the drain valve is removed from the washer.

Detergent Dispenser

Remove top panel to access dispenser. (see Removing Top Panel) Detergent is flushed from the front of the compartment and fabric softener is flushed from the back. There will be a small amount of water left in the fabric softener compartment after each use.

Injection Assembly

In the left rear of the cabinet is the injection assembly. It guides the water and injection chemicals to the tub and dispenser and prevents a back flow of water.

Water Valves

Remove top panel to access water valves. (see Removing Top Panel) The two dual outlet water and/or single coil valves are mounted to the rear channel with two screws each. Always check inlet screens to be sure that they are clean. Disassembly requires the removal of two solenoid screws and three valve body screws. Below the solenoid coil is a solenoid guide, armature, armature spring and diaphragm. All valve parts are available individually or as a complete unit.

Door Lock Assembly Operation

After loading the clothing, the door should be closed and latched. After selecting your preferred cycle and pressing start, the solenoid in the door lock mechanism engages. This will prevent the door from being able to be opened until specific conditions are met. These conditions are:

- The drum is no longer turning for 10 seconds
- There is no water in the tub,

If either of these conditions are not met, the door lock solenoid will remain engaged.

Accessing the Door Lock Assembly

After removing the front panel and masking ring, the door lock assembly can now be accessed.

Removal of the Door Lock Assembly

- Step 1: Remove the top panel (following previous procedure).
- Step 2: Remove the front panel (following previous procedure).
- Step 3: Remove loading door (following procedure below).
- Step 4: Loosen masking ring nuts to lift up on masking ring to gain clearance underneath masking ring to disconnect red/blu/wht door lock wiring harness and yellow displacement switch wires.
- Step 5: Remove masking ring by flipping upside down and laying on top of machine.
- Step 6: Use 5/32 hex tool/key to remove the 3 bolts that hold door lock.

Reverse this procedure for installation.

Door Lock Assembly Release

If power is off to the machine and the door is in a locked state, or if the door lock fails to open there is a manual override release button.

When the machine is in a failed state with the door locked and not in cycle, you will need a stiff wire or rod around 1/16" thick.

When you insert the rod into the hole in the front panel next to the door ring (9:00 position), depress until it releases the door lock.



Door Lock Assembly in Power Outage

If you have a power outage the door will unlock during the boot process when power is restored to the machine. The control will not save its place in the cycle. The control will revert to cycle selection. You will then be prompted to select and start a new cycle.

Door Glass Gasket Removal

- Step 1: Remove loading door (following procedure below).
- Step 2: Remove glass and gasket off the door ring by lifting and rolling the gasket off the ring.
- Step 3: Remove the gasket from the door glass using a utility knife.
- Step 4: Remove excess silicone residue.

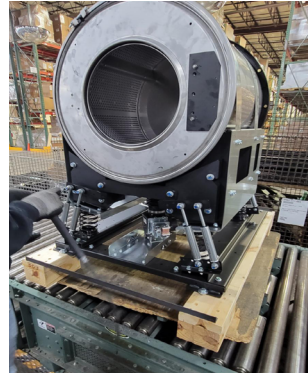

Door Glass Gasket Installation

- Step 1: Clean glass surface.
- Step 2: Place glass gasket with large gap opening facing upward on flat surface.
- Step 3: Place minimum 1/8" bead of silicone deep into large gap groove of gasket.
- Step 4: Place glass face down on a flat surface.
- Step 5: Press large gap of gasket around door glass edge.
- Step 6: Clean excess silicone and cure for 24 hours.
- Step 7: Install door ring to door glass gasket assembly.



Max Displacement Switch Reset

When the switch is tripped (the plunger is pushed in) the cycle should stop, the drain valve will open, and the display will show a message that the switch has been tripped.

To reset the washer, pull out the plunger on the switch and follow the instructions on the display to reset the washer. To access the plunger switch, remove the lower panel and access switch on the left side.

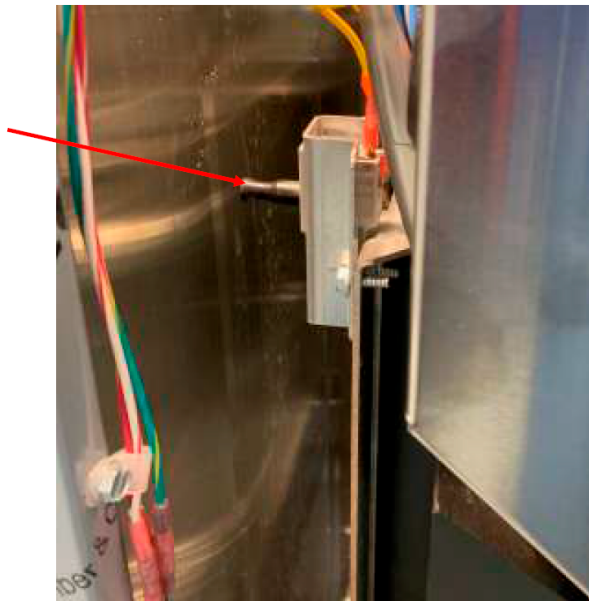

Adjusting the Loading Door

The door can be adjusted by changing the number of shims behind the door hinge and the door lock assembly. The vertical fit of the door to the tub can be altered by loosening the door hinge bolts and raising or lowering the door before retightening. It is important for the door to be centered on the tub front. By chalking the front of the tub and closing the door to transfer that line to the gasket, the centering can be evaluated. It is also important for door pressure to be similar around the door perimeter. Door pressure can be evaluated by inserting a dollar bill in several positions and tugging on it. See Parts Section for kit to increase door sealing pressure.

Loading Door Removal

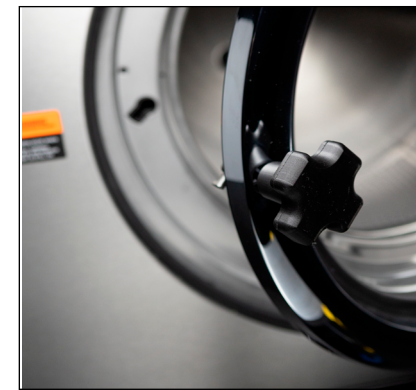

- Step 1: Support door to prevent dropping.



- Step 2: Remove 2 bolts holding the lower leaf hinge and set door off.

Loading Door Hinge Removal

- Step 1: First remove loading door, front panel, and masking ring.



- Step 2: Remove 3 screws holding door hinge. Shims may be present between hinge and tub front. The number may be increased or decreased to adjust right side door pressure.

NOTE:

Door hinge mounting bolts penetrate tub front and require silicone sealer applied to holes when reinstalling.

Control Panel Name Plate Decal

The name plate on washer front is adhesive backed.

Control Panel Name Plate Removal

The name plate may be removed by simply peeling it off.

Re-Installation of Name Plate

Step 1: Remove any remaining glue from the control panel.

Step 2: Before removing the paper backing from the name plate, check fit to the control panel. The program push buttons are the locating guides.

Step 3: Remove the paper backing from the right side of the name plate, position it on the panel and press right end into place. Peel the backing from the left end and press into place.

Damper Removal

Step 1: Remove lower service door by removing 2 mounting screws.

Step 2: Remove top and bottom mounting bolts from damper.

Step 3: Remove damper.

Reverse this procedure for installation.



Spring & Spring Pad Removal

Step 1A: For rear springs, remove back panel as described previously.

Step 1B: For front springs, remove lower service door as described previously.

Step 2: Remove the three dampers from the frame and cradle assembly as described previously.

Step 3: Using a lifting tool, slightly lift the tub and cradle assembly up 1".

Step 4: Remove the four screws from the top spring pad.

Step 5: If needed, raise tub and cradle assembly more with lifting tool to give more clearance to remove the 4 screws from the bottom spring pad and remove the spring and spring pads.



Reverse this procedure for installation.

NOTE: There are different spring and spring pad sets for the right and left-hand sides, please pay attention to the part numbers and part coloring.

Drive Belt Removal

Turn the drive pulley while applying pressure to the drive belt until it rolls off of the basket pulley first and then remove from the motor pulley.

Reverse this procedure for installation.

Drive Belt Tensioning

Step 1: Add motor bracket to base. Tighten bolts of motor to machine at 40 ft/lbs

Step 2: Leave the 4 side bolts loose until the motor and belt are set.

Step 3: Install belt as described previously.

Step 4: Add set screw and jam nut to motor bracket. This screw can be adjusted in to make the belt have a tighter tension; or out to loosen the belt tension. The range for belt tension is 110-125 ft/lbs

Step 5: Use the Belt tension tool to determine what you tension you are in range at on the machine. Once the tool says you are in range of 110-125 ft/lbs. You can set the jam nut.

Step 6: Once belt is set to rating, tighten jam nut against the plate so the set screw stays in place.

Step 7: Once jam nut is tight, Torque the 4 bolts of the motor bracket to 40ft/lbs. Be sure to mark green that you torqued these bolts.

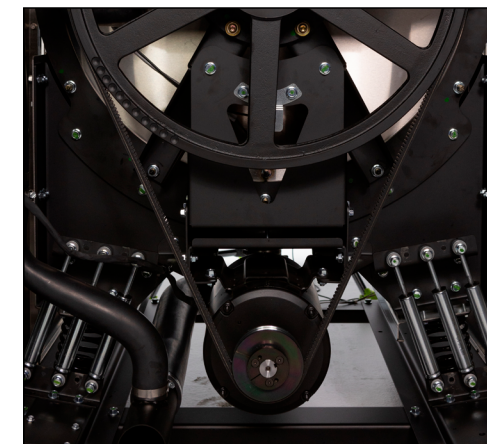

Drive Belt

Cylinder (basket)

- Step 1: Remove the top panel as described previously.
- Step 2: Remove lower service panel by removing mounting screws.
- Step 3: Remove front panel as described previously.
- Step 4: Remove masking ring as described previously.
- Step 5: Remove door lock assembly. (Leave wires & pull rod place)
- Step 6: Remove clothes door.
- Step 7: Remove tub front clamp ring.
- Step 8: Remove tub front. Use a flat screw driver to pry the tub front loose.
- Step 9: Remove the rear access panel.
- Step 10: Remove the drive belt.
- Step 11: Remove drive pulley. Remove 3 retaining screws. Insert (3) 3/8 16 x 2" screws into the threaded removal holes. Alternately tighten these screws evenly to pull the pulley off.
- Step 12: Remove pulley hub. Drive a flat screw driver into the slot in the hub and pull it from the shaft.
- Step 13: Install cylinder puller. (Snap On part #CJ-84-C) Be sure to thread a 5/8-11 NC bolt into the end of the cylinder shaft to protect the threads. Push the basket out.

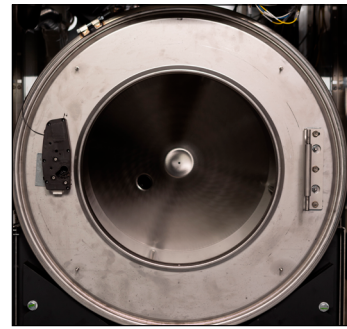

two
in

Bearing Housing Assembly

Removal

- Step 1: Remove cylinder from washer (see Cylinder (basket) removal).
- Step 2: Remove 6 tub back to bearing housing cap screws.
- Step 3: Remove 6 bearing housing to frame bolts.
- Step 4: Remove bearing housing from frame.
- Step 5: Remove the retaining ring next to the front bearing.
- Step 6: The bearings are pressed into the housing and must be pressed back out.



Reassembly

- Step 1: When installing new bearings into a bearing housing, first press the front (large) bearing into the housing until it bottoms and install the snap ring. With the bearing spacer in place, press the rear bearing in until the spacer is snug between the two bearings.

NOTE: If the tub-back water-seal mating ring has been moved it must be cleaned and resealed

Water Seals

Replacement

- Step 1: Remove cylinder from washer (see Cylinder (basket) removal).
- Step 2: Remove water seals from the seal mounting plate on the cylinder shaft. These are removed with your fingers.
- Step 3: The primary and secondary seals that mount on the sealing ring may be slid over the shaft and seated on the metal sealing ring with your fingers. In the unlikely event that the metal ring that mounts these sealing rings were to be damaged or moved, a new one would need to be pressed on. The seal mounting ring must be pushed against the stop on the shaft. After installing the seals, lubricate the faces of the seals with silicone grease.
- Step 4: Install cylinder (see Cylinder (basket) reassembly).

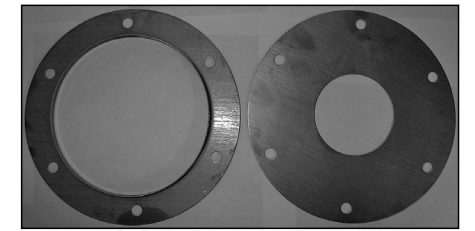

Guard Ring & Mating Ring

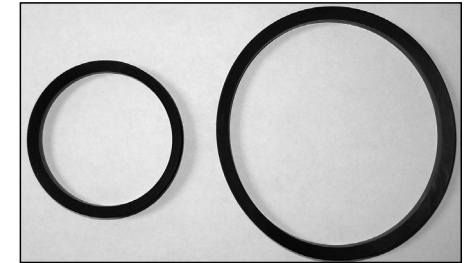

Seals

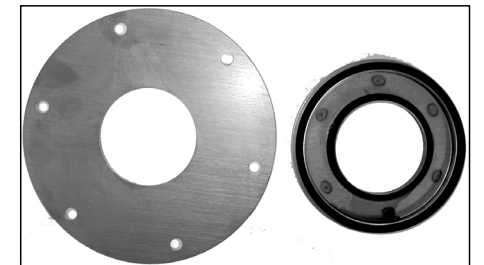

Mating Ring & Mounting Ring

Outer Tub

Removal

- Step 1: Remove the top panel as described previously.
- Step 2: Remove lower service panel as described previously.
- Step 3: Remove front panel as described previously.
- Step 4: Remove back panel as described previously.
- Step 5: Remove masking ring as described previously.
- Step 6: Remove tub front. Use a flat screw driver to pry the tub front loose.
- Step 7: Disconnect all wires and hoses that connect or mount to tub.
- Step 8: Remove belt as described previously.
- Step 9: Remove bolts on tub band clamps.
- Step 10: At this point, the only attachments are the bolts from rear tub mounting ring to cradle.



Reassembly of the Cylinder

- Step 1: Use the hub of the drive pulley, a stack of 5/8" flat washers and a 3" long 5/8" bolt to pull the cylinder shaft through the bearings. After the 3" bolt a 2" long bolt will be required to finish pulling the cylinder shaft through.
- Step 2: Clean the silicone rubber off the tub front and the outer tub.
- Step 3: Install new bead of silicone rubber on tub front.
- Step 4: Install tub front.
- Step 4A: Align hole in top of tub front with notch in top of outer tub. Using the etched guide lines in the outer tub measure both sides from frame to line and make sure measurements match exactly.
- Step 4B: Use 4-6 #11R vise grip clamps to hold tub front to outer tub. A rubber mallet may be needed to properly seat the tub front into the outer tub.
- Step 4C: Install tub front gasket around outer edge of tub front and outer tub flange. The opening should be centered at the top.
- Step 4D: Remove vise grips. The tub front gasket will hold the tub front in place.
- Step 5: Install tub front clamp ring and tighten. Tap around the clamp ring with a rubber mallet to seat the ring and gasket while tightening the clamp ring bolt.
- Step 6: Adjust clearance between the outer tub front and the front lip of the cylinder to 5/16".
- Step 7: Remove Dexter Tool part 8545-056-001 from the back of the outer tub.
- Step 8: Install drive pulley.
- Step 8A: Install hub on cylinder shaft.
- Step 8B: Hold hub against rear bearing with 5/8" bolt and flat washer in end of cylinder shaft.
- Step 8C: Line up 3 unthreaded holes in pulley with the 3 threaded holes in hub.
- Step 8D: Insert 3 pulley bolts and tighten evenly alternating bolts to 30ft/lbs.
- NOTE:** Overtightening or uneven tightening can break drive pulley.
- Step 9: Install drive belts & back panel.
- Step 10: Install door lock. All mounting holes should be sealed with silicone rubber.
- Step 11: Install door, masking ring, front panel, lower service panel and top panel.

S-975 Bolt Torque Chart

Bolt Part Number	Bolt Size	Where Used	Torque	Qty.
9545-029-016	3/8-16x1 1/2	Tub Back	40 ft-lb	7
9545-029-015	3/8-16x3/4	Motor Mounting	40 ft-lb	4
9545-029-017	3/8 - 16x2 1/2	Tub Bands	15 ft-lb	2
9545-029-015	3/8-16x3/4	Motor Mounting	40 ft-lb	16
9545-029-011	3/8-16 UNCX2	Drive Pulley Mounting	28-32 ft-lb	3
9545-060-001	5/8-11x1 1/2	Cylinder Shaft	100 ft-lb	1
9545-060-004	5/8-11x2	Bearing Housing to Tub Back	120-150 ft-lb	6
9545-067-001	1/2-20x 1 3/4	Bearing Housing to Spider Assy	145-160 ft-lb	6
9545-059-002	7/16-14x2	Spider Assy to Tub Ring	100-125 ft-lb	12
9545-029-015	3/8-16x3/4	Frame Mounting	40 ft-lb	20
9545-029-015	3/8-16x3/4	Cradle Assembly	40 ft-lb	48
9545-029-016	3/8-16x1 1/2	Damper Mounting	40 ft-lb	24
9545-017-020	1/2-13x6 1/2	Counter Weight Mounting	75 ft-lb	8

Control Mounting Trough

Remove top panel to access control trough. It sets on the right side of the machine and holds the control PCB's, transformers, and water pressure switch.

Main Data Communication Cable

Goes between front PCB board and Variable Frequency Drive unit mounted center rear of machine. It has telephone type connectors at each end and is inserted at Controller PCB and the Variable Frequency Drive.

Fuses

The fuses mount in control trough. They carry all of the controls in the machine but they do not include the motor. Remove fuse and replace with a 1.5 amp fast blow type fuse to replace the fuse for the 120V circuit. Use a 2.0 amp slow blow type fuse to replace the fuse for the 24V circuit.

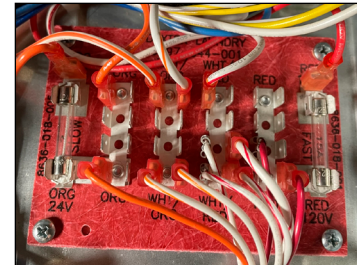

Fuse Location

Controls Transformer

This transformer is mounted at the back of the control trough and steps a range of 208 to 240 volts down to 120VAC and 24VAC. There are two terminals on the controls transformer for incoming power. One terminal tap is marked for 208 volts use this tap for measured voltage of 200 volts - 215 volts and the other tap is marked 230 volts for 216 volts - 240 volts. NOTE: All washers have a controls transformer. Always check the incoming voltage and use the appropriate transformer terminal when installing ALL washers.

Main Control/Relay Printed Circuit Board

Please be sure to be grounded to machine before removal of this board. Both of these PCB boards are mounted in the control trough. Remove 4 mounting nuts.

Graphics/Display Printed Circuit Board & Temperature Selector

The graphics board is mounted in the right hand side of the control panel and is held in place with four nuts. It allows the selection of hot, warm, or cold water temperatures as well as cycle selection. NOTE: Do not over tighten on reinstallation as the board can be damaged, can cause erratic displays.

Pressure Switch

The pressure switch sets the water level in the washer. As the water level rises, it compresses the air in the pressure switch hose. When the washer reaches the desired water level, the compressed air in the pressure switch hose opens the contacts in the switch, shutting off the water. When at the empty level, the pressure switch contacts are closed allowing the machine to either spin or fill with water.

Power Connection Terminal Block

This terminal block sets at the very back of the control trough. Incoming power to the washer should connect here. (see Electrical under Installation and Operation Section for exact connections)

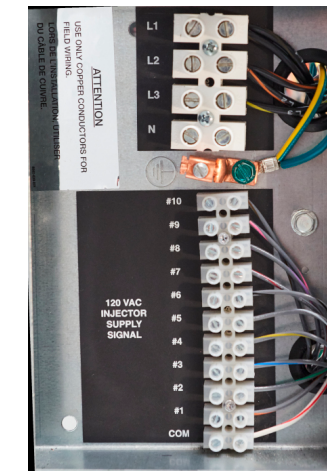

Rear

Delta Variable Frequency Drive:

Main power is connected to terminals L1, L2, and L3 on the Delta drive. If the washer is connected to a three phase source, there should be voltage present on all three terminals. If the washer is connected to single phase power, there should be voltage present on L1 and L2 terminals.

The voltage should measure 208 Volts to 240 Volts A.C. between phases and connected to if connected to three phase). There is a tolerance of + 10% on the mains voltage (187 Volts to 264 Volts).

Delta VFD Motor Leads:

The wires from the motor are connected to terminals T1, T2, and T3. Since this drive uses pulse width modulation, an accurate current or voltage reading is not possible. Although an accurate current reading is not possible, a balanced current reading should be present while the motor is running.

Delta VFD Dynamic Braking Resistors:

Two, 160 Ohm or 200 Ohm braking resistors (Please check your washer model parts requirements and quantities), are connected in parallel and attached to the drive at terminals B1 and B2. These resistors allow voltage, which is generated by the motor when decelerating, to be dissipated. They will become hot while the motor is slowing down, so care should be taken so as not to come in contact with them. This will prevent an electrical shock and/or a physical burn.

Delta VFD Cooling Fan:

There is a cooling fan attached to the bottom of the Delta drive. This fan will operate when the internal temperature of the drive reaches a predetermined level, the same way the radiator fan in a newer car operates. THE FAN CAN OPERATE ANYTIME POWER IS APPLIED TO THE DRIVE! Remove power to the drive if work is required around the fan.

Electrical Path Circuit Schematics

Start Circuit

Power travels into the machine on L1, L2, and (L3 if 3 phase used). Power from the L1 & L2 supplies power to the 12VDC power supply. This power being sent to the Control PCB. 115VAC, 24VAC, and the VAC Neutral is created by the control transformer. The 115VAC and 24VAC is being sent to the Terminal Blocks. Power from the L1 and L2 also supplies power to the 12VDC power supply. The 12VDC power is sent directly to the Control PCB on the blue wires.

- All 115VAC power is designated in the machine by red wire connections and the 115VAC neutral is designated by white wires with a red stripe. All 115VAC begins at the terminal block for 115VAC supplied through a control fuse located next to the terminal strip.
- All 24VAC power is designated in the machine by orange wire connections and the 24VAC neutral is designated by white wires with an orange stripe. All 24VAC begins at the terminal block for 24VAC supplied through a control fuse located next to the terminal strip.
- All 12VDC power is designated in the machine by blue wire connections and the 12VDC ground is designated by white wires with a blue stripe.

A 12VDC signal to J11-2 of the Control PCB and 120vac at the J4-14 of the relay PCB makes 120vac available to the K9 door lock relay. A continuous 5VDC signal is sent out on the J11-6 brown wire and returned on the brown/white wire to the J11-3 connector of the control PCB. This is passed through the (normally closed) emergency stop button switch.

The Washer is ready for operation.

The cycle is selected using the up and down buttons. The start button is now pressed. The control signals the relay board to close relay K9 sending 120VAC to the door lock. At the same time the K5 relay is engaged sending an enable signal to the variable frequency drive. 120VAC will go to the door lock assembly from the P11 connector of the main control PCB.

NOTE: If the door locked signal is not received after one second from pressing the Start button, no motion occurs and the error message "DOOR SHUT, NOT LOCKED" will appear on the display. The washer will not restart until the power is removed and re-applied.

Agitation Circuit

When the 12VDC signal closes the K5 in the Control PCB it closes the loop in the yellow wire from the VFD terminal MI6 back to the DCM on the white/yellow through the stop button. This enables the Drive to operate and allow motion. If the K5 is not closed or the Aux Stop Button is engaged there will be no motion. A proximity sensor is used to verify that the cylinder is turning when the VFD is commanded to operate. If the VFD frequency is greater than 0 Hz and the proximity sensor has no change in output for 10 seconds, the error code "NO PROX SENSOR OUTPUT" is displayed. The K7 Closes supplying 120VAC on the red/brown to energize the Drain Valve. This supplies power to close the valve. The main control PCB sends data commands to the VFD through the data cable connected at P-2. These commands control all wash cylinder movement. The type of agitation is programmed in the control settings.

- o Agitation type: Normal, delicate, or 3 custom options
- o Agitation time
- o Spin speed
- o Spin time

Fill Circuit-Warm Stage

During the machine fill, a 12VDC signal is sent on the blue wire from the J8-1 connection of the main control PCB to the pressure switch common contacts. This 12VDC returns on the blue/yellow wire for low level and blue/red wire for high level.

NOTE: Unlike the other previous Dexter washers, with O-Series Controls the empty signal is an open circuit, full is a closed circuit.

The washer fills the tub through the back of the machine with either one or both the C1/C3 cold and H1/H3 hot water fill valves. From the P4 connection of main relay PCB, 120VAC is sent out of the K4 relay on the red/pink wire to the C1/C3 cold water fill valve. 120VAC is sent out of the K1 relay on the red/grey wire to the H1/H3 hot water fill valve depending on the programmed bath temperature. If the washer does not initially reach low water level within 7 minutes the cycle will continue and "SLOW FILL ERROR" will be displayed alternately with the Cycle Progress screen. (This is the case unless "None" is chosen for fill level). The alternating "SLOW FILL ERROR" will be displayed the rest of the cycle even when the "CYCLE DONE" screen is displayed. It will reset when the user opens the door.

If the "SLOW FILL ERROR" occurs after 7 minutes and the water level is still not met at 15 minutes, the washer will come to a controlled stop. The current stage will end, and the cycle will not continue. The "SLOW FILL ERROR" will be displayed on the screen until reset. Even on high fill, as long as the low water level is met one time during a stage, the "SLOW FILL ERROR" will not be displayed during the remainder of the stage. This includes if the low water level is met before 7 minutes, then drops again and requires additional filling.

Soap Dish Flush / Injection Signals

The signal for the Detergent, Softener, or Injection Signals are programmable to engage for 0 to 150 seconds. By setting up the injection or flush in the programming, a 120VAC signal will be sent from the main or secondary relay board to a specific flush valve or injection terminal on the back of the machine. The Hot Detergent flush is powered from the Red/Black of the main relay board. The Cold Softener flush is powered from the Red/Violet of the main relay board. All Injection Terminal Strip signals are powered from the Grey wires of the secondary relay board. All 120VAC neutral is carried through the white/red wires.

The Detergent Flush, Softener Flush, or Injection Signal start time is selectable from 0 to 150 second delay. The start time of the delay count down is dependent on the settings of the Delay Fill option. This Delay Fill option is a global setting which affects all stages of all cycles. The default setting is Delay Fill enabled which means that the Compartment flush or injection signal delay time will not start counting down until AFTER the low level fill has been achieved. (If the setting is changed to "disabled", then the countdown will begin from the beginning of the stage.

WS0975XB-12EO Schematic

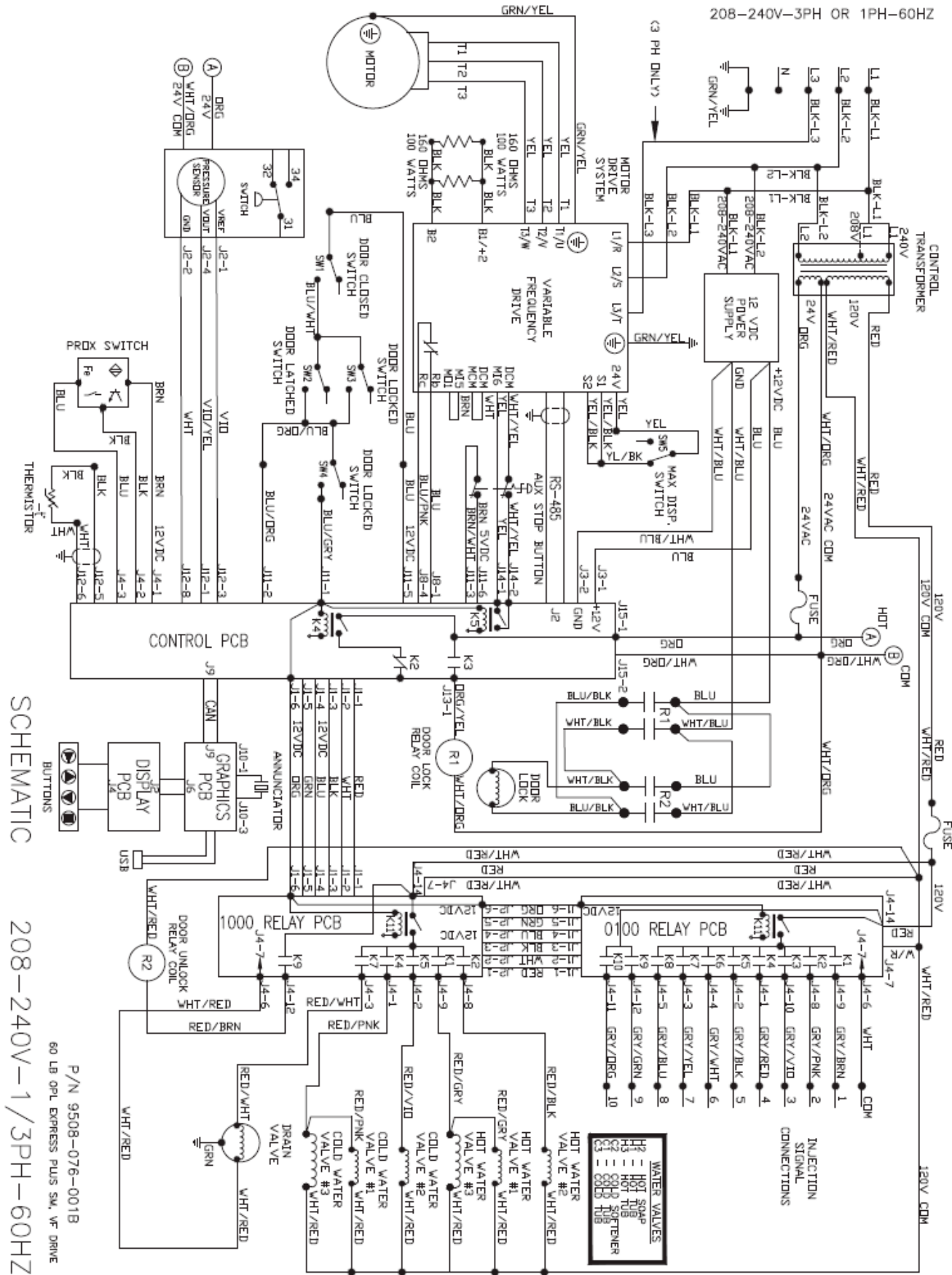

SCHEMATIC 208-240V-1/3PH-60HZ

P/N 9508-076-001B
60 LB OPL EXPRESS PLUS SM, VF DRIVE

WS0975XB-12EO Diagram

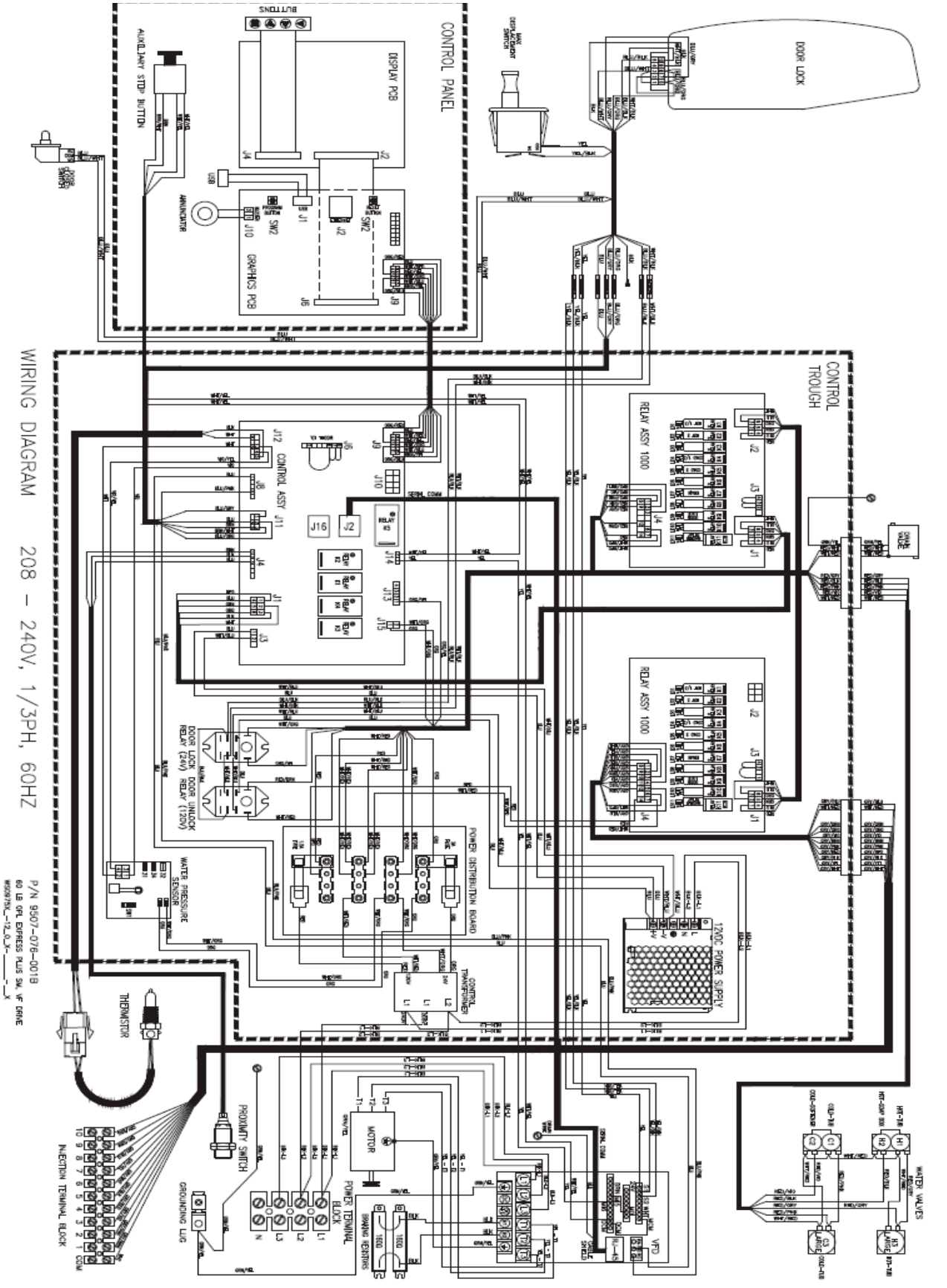

P/N 9507-076-001B
60 LB OPL EXPRESS PLUS SM, VF DRIVE
950975XB-12EO

Soft Mount O-Series OPL Accessories

WS0675XA-12EO 208-240 Volts 60 Hz Single or Three Phase
 WS0975XA-12EO 208-240 Volts 60 Hz Single Phase or Three Phase

Key	Description	S-675	S-975	QTY
*	Hose, Water Supply 5/8" I.D. x 48"	9990-027-013	9990-027-013	2
*	Hose, Water Supply 5/8" I.D. x 48"		9990-027-011	2
*	Rubber Washer, Inlet Hose (furnished)	8641-242-000	8641-242-000	2
*	Strainer, Inlet Hose (furnished)	9565-003-001	9565-003-001	2
*	Rubber Washer, Inlet Hose (furnished)	8641-242-000	8641-242-000	2
*	Strainer, Inlet Hose (furnished)	9565-003-001	9565-003-001	2
*	Sealing compound RTV-45	8538-151-002	8538-151-002	1
*	Flow Restrictors (in dispenser)	9475-002-005	9475-002-005	2
*	Key Service Lock (6324)	6292-006-007	6292-006-007	1
*	USB Thumb Drive W/Operator Booklets all sizes	9150-045-002	9150-045-002	1
*	Base Assembly - 1 Place, 6"	9945-164-001	9945-163-001	1
*	Leveling Leg	8544-008-001	8544-008-001	4
*	Leveling Leg Kit	9732-361-001	9732-361-001	1



Section 8: Parts Data

WS0675XB-12EO 208-240 Volts 60Hz Single Phase or Three Phase
 WS0975XB-12EO 208-240 Volts 60 Hz Single Phase or Three Phase

Kits, Assemblies & Common Parts

Description	S-675	S-975
Drain Valve 3"	9379-204-001	9379-204-001
Water Valve (Dual)	9379-183-012	9379-183-012
Water Valve (Single)	9379-194-001	9379-194-001
Diaphragm	9118-049-003	9118-049-003
Cylinder Plug (1.5" Plastic)	9456-041-007	9456-041-007
Water Pressure Sensor Assembly	9474-007-001	9474-007-001
Drive Display	9150-058-001	9150-058-001
Breaking Resistor 160 Ohms	9483-004-003	9483-004-003
Transformer	8711-017-001	8711-017-001
Main Control Board	9857-230-003	9857-230-003
Data Cable	9806-023-005	9806-023-005
Door Lock Assembly	9885-032-001	9885-032-001
Door Handle Only	9244-096-001	9244-096-001
Front Panel Screw	9545-008-014	9545-008-014
Front Panel Finisher Washer	8641-585-001	8641-585-001
Front Panel Expansion Nut	8641-585-001	8641-585-001
Soap Box Screw	9545-008-012	9545-008-012
Soap Box Spring Nut	8640-399-007	8640-399-007
Lock, Top (w/Key)	8650-012-003	8650-012-003
Fuse 1.5amp	8636-018-001	8636-018-001
Fuse 2.0amp	8636-018-005	8636-018-005
Door Glass Gasket	9206-431-002	9206-431-002

Wiring Harness Parts Group

Key	Description	S-675	S-975	
*	Cableassy-usb,snapi	9806-024-001	9806-024-001	1
*	Cableassy-data,rs485,49"	9806-023-005	9806-023-005	1
*	Wiringharness-doorlock/doorsw	9628-016-002	9628-016-001	1
*	Wiringharn-pwr/VFD/ps		9627-932-003	1
*	Wiringharness-15pin,injection		9627-935-003	1
*	Wiringharness-15pin,non-inj	9628-011-001	9628-011-001	1
*	Wireasy-jumper,blk		8220-117-002	2
*	Wireasy-brn,#21,3"	8220-057-035	8220-057-035	1
*	Wireasy-wht,3"	8220-057-036	8220-057-036	1
*	Wireasy-jumper,wht/red	8220-123-002		1
*	Wireasy-jumper,wht/red		8220-119-003	2
*	Wireasy-red/pnk,8"		8220-108-012	1
*	Wireasy-red/gry,8"		8220-108-013	1
*	Wiringharn-ctrl,graph,can,wshr	9627-922-002	9627-922-002	1
*	Wiringharness-main, nonhtd	9628-010-001	9628-010-001	1
*	Wiringharness-chemical,v2.0wshr	9627-927-001	9627-927-001	1
*	Wiringharness, drsw/VFD/stp	9627-928-004	9627-928-004	1
*	Wiringharness-cntrl/relay,v2.0	9627-921-001	9627-921-001	2
*	Wiringharness-wps/therm	9628-017-001	9628-017-001	1
*	Wiringharness-pwrsup,v2.0wshr	9628-012-001	9628-012-001	1
*	Wireasy-jumper,v2.0,relaypcb	8220-159-005	8220-159-005	1
*	Wireasy-jumper,v2.0,relaypcb	8220-159-006	8220-159-006	1
*	Wireasy-wht/org,17 1/2"	8220-062-053	8220-062-053	1
*	Wireasy-org,17"	8220-062-052	8220-062-052	1
*	Wiring harness-drkrelay	9628-013-001	9628-013-001	1
*	Wiring Harness - rebal, input	9628-014-001	9628-014-001	1
*	Wiring harness, maxdispsto	9628-015-001	9628-015-001	1
*	Wireasy-2.0,s675	8220-158-034		1

Cabinet and Front Panel Group Parts Group

Key	Description	S-675	S-975	Qty
1	Panel, Side Right - stainless	9989-713-001	9989-707-001	1
1	Panel, Side Left - stainless	9989-713-002	9989-707-002	1
*	Bolt-1/4-20x1/2 (side panel to baser)	9545-018-013	9545-018-013	8
2	Panel Assy, Front	9989-712-001	9989-706-001	1
*	Trim Edge Protector	9578-105-003	9578-105-002	1
3	Bumper Loading Door	9051-055-001	9051-055-001	1
*	Nut, 1/4 x 20 for bumper	8640-414-003	8640-414-003	1
*	Screw, #10B x 1/2	9545-008-026	9545-008-026	12
*	Nut, Expansion- To Control Panel	8640-442-001	8640-442-001	2
4	Screw, Flat Head- Front to Sides	9545-008-014	9545-008-014	4
5	Washer, Finish	8641-585-001	8641-585-001	4
*	Nut, Expansion-To Front Panel	8640-442-001	8640-442-001	12
*	Label, Door Opening (Black)	8502-788-001	8502-757-001	1
*	Panel, Control (Mounts Nameplate)	9989-715-001	9989-708-001	1
*	Screw, Control Panel to Sides	9545-008-026	9545-008-026	6
6	Nameplate Decal, Control Black	9412-263-001	9412-262-001	1
7A	Panel Top Front		9989-704-001	1
7B	Panel Top Rear		9444-081-001	1
7	Top Panel (One Piece)	9444-133-001	9444-132-001	1
8	Lock, Top (w/Key)	8650-012-003	8650-012-003	1
*	Lock Spacer	9538-139-001	9538-139-001	1
9	Door, Lower Service, Includes Handle	9960-286-012	9960-286-001	1
10	Handle (bumper guard)	9244-086-008	9244-086-007	1
*	Rivet Blind 3/16" Alum	9491-009-003	9491-009-003	4
11	Screw Mtg., Flat Head 10Bx1 3/4	9545-008-014	9545-008-014	4
12	Washer, Finish	8641-585-001	8641-585-001	4
13	Key, Top- # 6324	6292-006-007	6292-006-007	2
14	Washer Flat 5/16	8641-581-008	8641-581-008	2
15	Cam, Lock-Top	9095-049-001	9095-049-001	2
16	Nut, 7mm x 1.0 Hex	8640-426-001	8640-426-001	1
17	Switch, Max Displacement	9539-487-002	9539-487-002	1

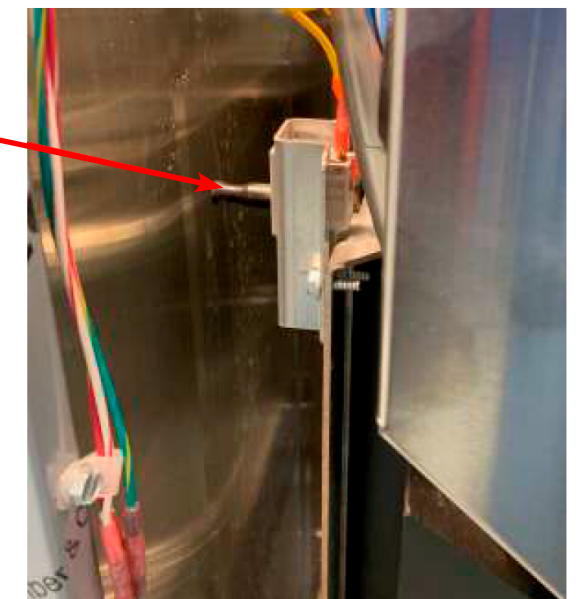
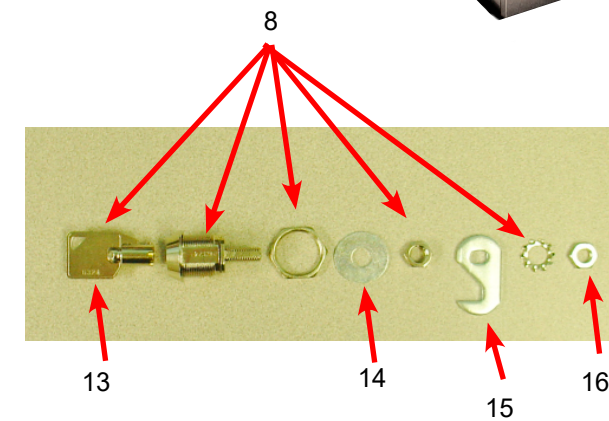
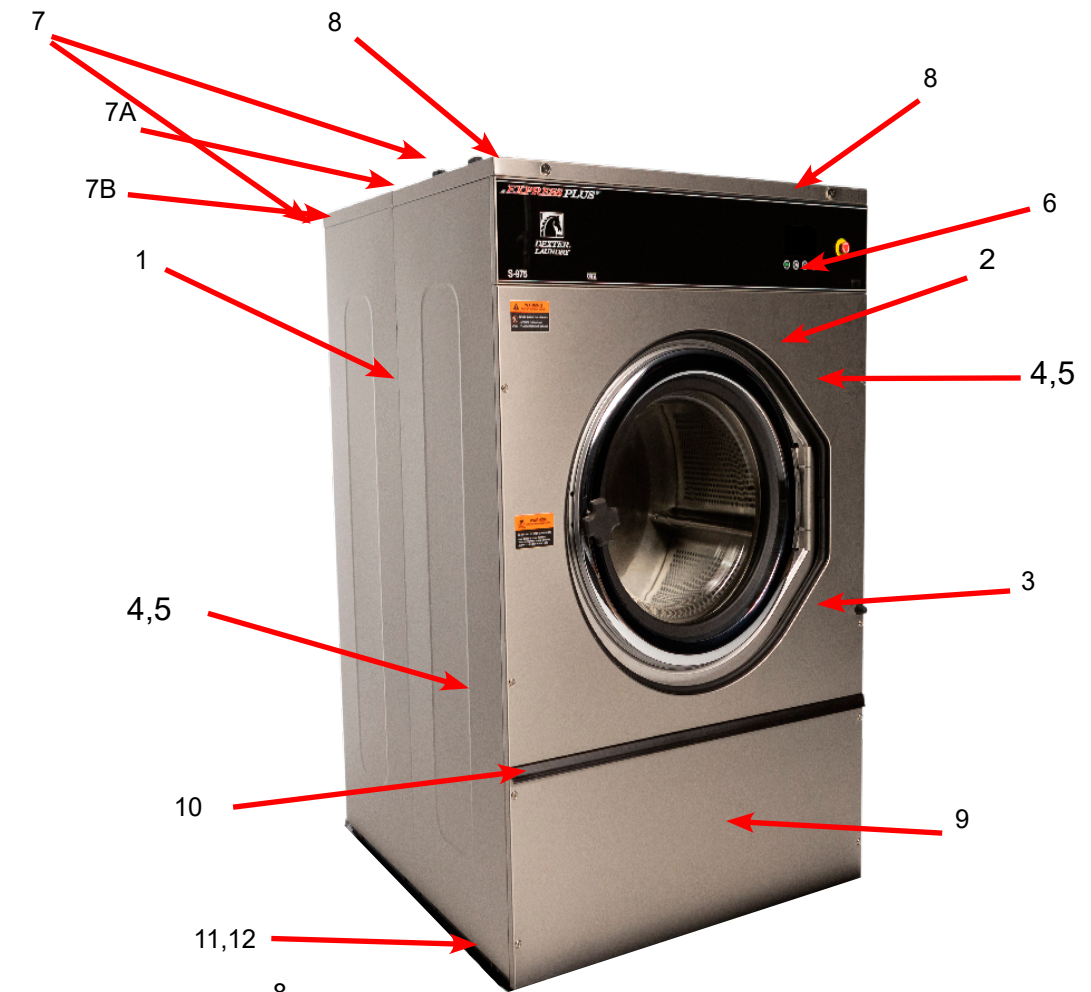

Rear View Access Parts Group

Key	Description	S-675	S-975	
1	Drive Motor	9376-338-001	9376-326-003	1
2	Pulley, Motor	9453-193-001	9453-190-001	1
*	Set Screw	9545-014-007	9545-014-015	1
*	Nut	8640-400-002	8640-400-002	1
*	Split TaperBushing (motor pulley)	9053-077-001	9053-077-001	1
*	Screw taper bushing 1/4-20x1	9545-018-024	9545-018-024	3
3	Pulley, Driven	9453-168-006	9453-176-006	1
4	Bracket-Motor, Hang	9029-358-002	9029-345-002	1
*	Screw 3/8-16 3/4	9545-029-015	9545-029-015	16
*	Nut 3/8-16	8640-415-004	8640-415-004	16
5	Bracket-Motor Support	9985-215-002	9985-212-002	1
*	Screw 3/8"-16 x 2"		9545-029-011	3
*	Washer, 3/8"		8641-582-003	3
*	Screw 3/8"-16 x 2"	9545-029-011		2
*	Washer, 3/8"	8641-582-003		2
6	Drive Belt	9040-079-010	9040-079-006	1
*	Screw 1/2-6X3 1/2	9545-017-015	9545-017-015	4
*	Washer, Flat 1/2	8641-581-001	8641-581-001	4
*	Panel Assy., Back, Lower	9444-089-001	9444-082-001	1
*	Panel Assy., Back, Upper	9444-090-001	9444-083-001	1
*	Screw Panel Mtg.#10Bx1/2"	9545-008-026	9545-008-026	AR
*	Nut, Expansion	8640-442-001	8640-442-001	AR
*	Screw, To Base-1/4" x 3/4"	9545-030-002	9545-030-002	4
7	Injection assy	9883-017-001	9883-016-001	1
*	Hose, Injection Tube to Tub	9242-473-001	9242-473-001	1
*	Clamp, Injection Hose	8654-117-014	8654-117-014	2
8	Cap-injectorassembly	0935-127-001	0935-127-001	1
*	Clamp-hose		8654-117-017	2
*	Clamp-hose	8654-117-015	8654-117-015	2
*	Clamp-hose	8654-117-009		1
9	Hose-Overflow Upper	9242-477-001	9242-471-001	1
*	Tube Assy-Overflow	9915-136-002	9915-136-002	1
10	Hose-Overflow Lower	9242-475-001	9242-475-001	1
11	Clamp-Hose Over Flow	8654-117-014	8654-117-014	4
*	Bracket-Overflow Hose	9029-351-001	9029-351-001	1
12	Drain Tube Assembly	9915-134-002	9915-134-002	1

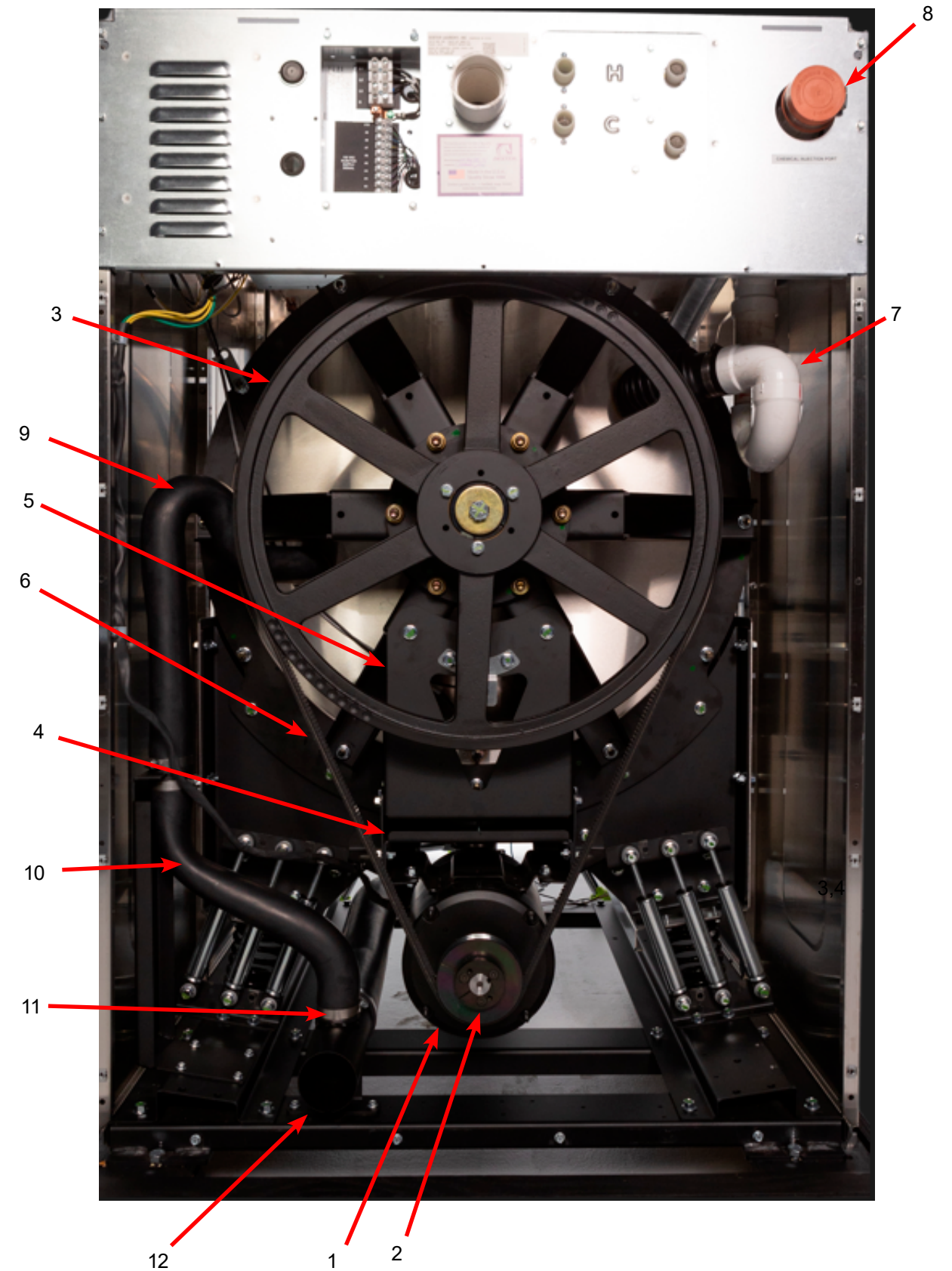

Cylinder, Seals & Bearings Parts Group

Key	Description	S-675	S-975	
1	Housing, Bearing- Assembly (items #2-#6)	9803-186-001	9803-231-001	1
*	Housing, Bearing	9241-180-002	9241-208-002	1
*	Bearing, Front (LARGE)	9036-159-005	9036-159-006	1
*	Bearing, Rear (SMALL)	9036-159-004	9036-159-005	1
*	Spacer, Bearing	9538-167-001	9538-190-001	1
*	Ring, Bearing Retainer	9487-238-003	9487-238-004	1
2	Tub Assembly	9930-189-001	9930-188-001	1
3	Seal, Small	9532-140-006	9532-140-007	1
4	Seal, Large	9532-140-009	9532-140-008	1
5	Ring Assy, Seal Mounting	9950-048-001	9950-052-001	1
6G	Ring-Seal Tub Back	9487-291-001	9487-295-001	1
6	Ring-Seal Mating	9487-261-003	9487-261-006	1
*	Bolt, Tub End of Bearing Housing, Bolt from inside Tub	9545-060-001	9545-060-004	6
*	Nut, Hex	8640-425-001	8640-425-001	6
7	Screw-Hex Cap, (Bearing Housing to Spider Assy)	9545-060-001	9545-067-001	6
8	Washers Interlocking (Bearing Housing to Spider Assy)	8641-591-002	8641-591-001	12
9	Nut 1/2-20 (Bearing Housing to Spider Assy)	8640-425-001	8640-443-001	6
10	Pulley, Driven	9453-168-006	9453-176-006	1
11	Bolt, 3/8"-16 x 2"		9545-029-011	3
12	Washer, 3/8"		8641-582-003	3
11	Bolt, 3/8"-16 x 2"	9545-029-011		2
12	Washer, 3/8"	8641-582-003		2
*	Bushing Taperlock		9053-078-002	1
13	Washer-Flat .675x2-1/2x1/4		8641-581-043	1
14	Lockwasher-Exttooth, 5/8		8641-582-018	1
15	Bolt, 5/8-11x1 1/2	9545-060-001	9545-060-001	1
*	Tub & Cylinder Assy	9869-048-001	9869-047-001	1

NOTE: Interlocking Washers are ONE-time use.

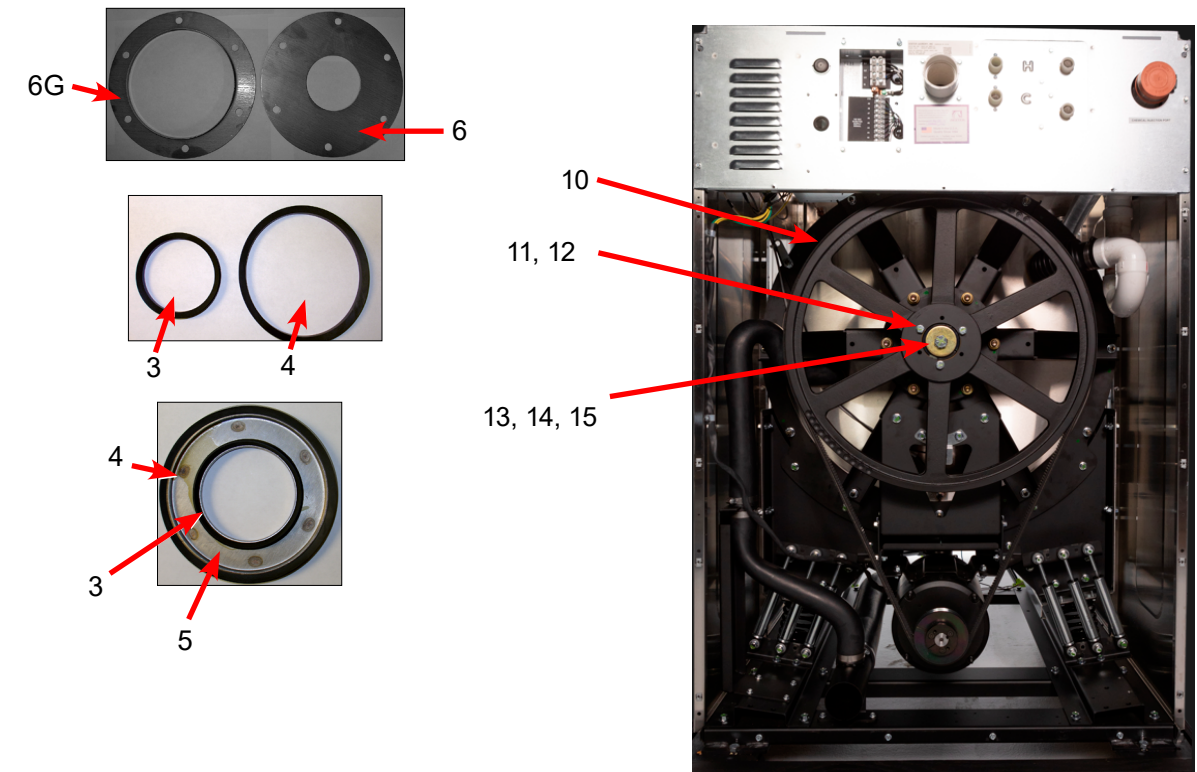

Key	Description	S-675	S-975	
*	Cylinder Assy	9848-168-001	9848-173-001	1
*	Tub Front	9974-024-001	9974-022-001	1
*	Gasket, Tub Front	9206-421-004	9206-421-002	1
*	Ring Assy, Tub Mtg-Front Clamp	9950-063-001	9950-055-001	1
*	Bolt, Top Front Ring 3/8"-16 x 3 1/2"	9545-029-009	9545-029-009	1
*	Nut 3/8"-16	8640-415-001	8640-415-001	1

Loading Door, Hinge, & Door Lock Parts Group

Key	Description	S-675	S-975	QTY
1	Door Hinge Assembly (mounts to tub front)	9955-033-001	9955-032-001	1
*	Door Assembly, Complete	9960-341-001	9960-336-001	1
2	Door Ring	9487-265-002	9487-275-001	1
3	Door Gasket	9206-419-002	9206-431-002	1
*	Sealing compound RTV-45	8538-151-002	8538-151-002	1
4	Door Glass Window	9635-016-001	9635-020-001	1
5	Switch, Door Hinge Close (Plunger)	9539-501-001	9539-501-001	1
6	Top Door Hinge Leaf	9845-011-001	9845-009-001	1
7	Bottom Door Hinge Leaf	9845-012-001	9845-010-001	1
8	Screw, Door Hinge Leaf Mtg	9545-056-002	9545-056-002	4
9	Screw, Loading Door Hinge Mtg - 5/16-18 x 3/4	9545-014-009	9545-014-009	3
*	Lockwasher	8641-582-009	8641-582-009	3
*	Shim-loading door hinge	9552-036-001	9552-043-001	2

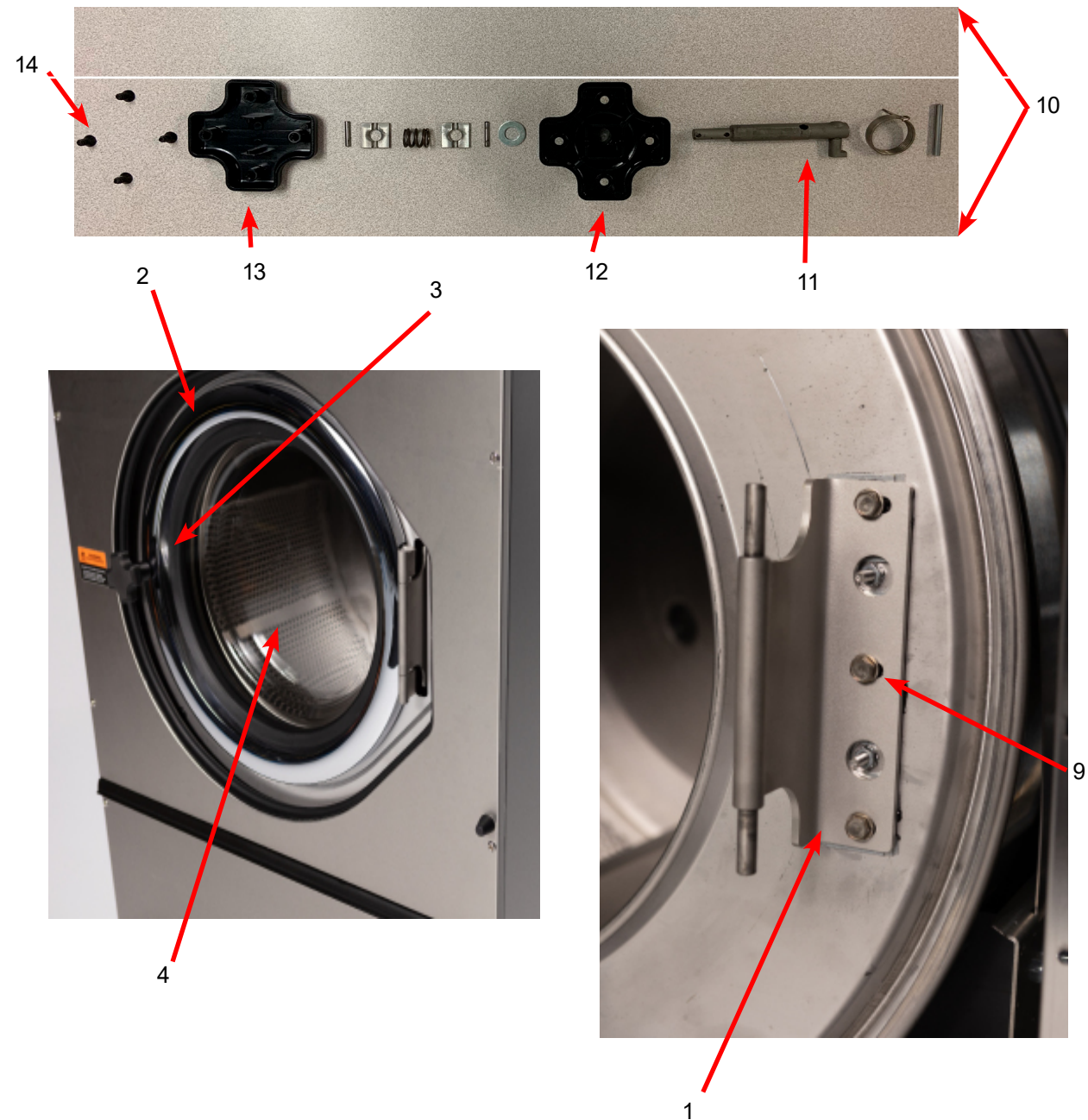

Key	Description	S-675	S-975	Qty
10	Door Handle Assembly (includes parts 10-11)	9965-028-001	9965-028-001	1
11	Door Lock Shaft Assembly	9913-137-001	9913-137-001	1
*	Pin-Handle Clutch	9451-203-001	9451-203-001	2
*	Disc-Clutch, Handle	9116-039-001	9116-039-001	2
*	Spring-Clutch, Handle	9534-370-001	9534-370-001	1
*	Washer, Flat	8641-581-009	8641-581-009	1
12	Handle, Door	9244-096-001	9244-096-001	1
*	Pin, Door Handle	9451-181-009	9451-181-009	1
*	Spring-Door Handle Return	9534-371-001	9534-371-001	1
13	Cover, Door Handle	9074-396-001	9074-396-001	1
14	Screw, Door Handle Cover	9545-008-038	9545-008-038	4
15	Door Lock Assembly	9885-032-001	9885-032-001	1
*	Shim-Door Lock	9552-051-001	9552-051-001	3

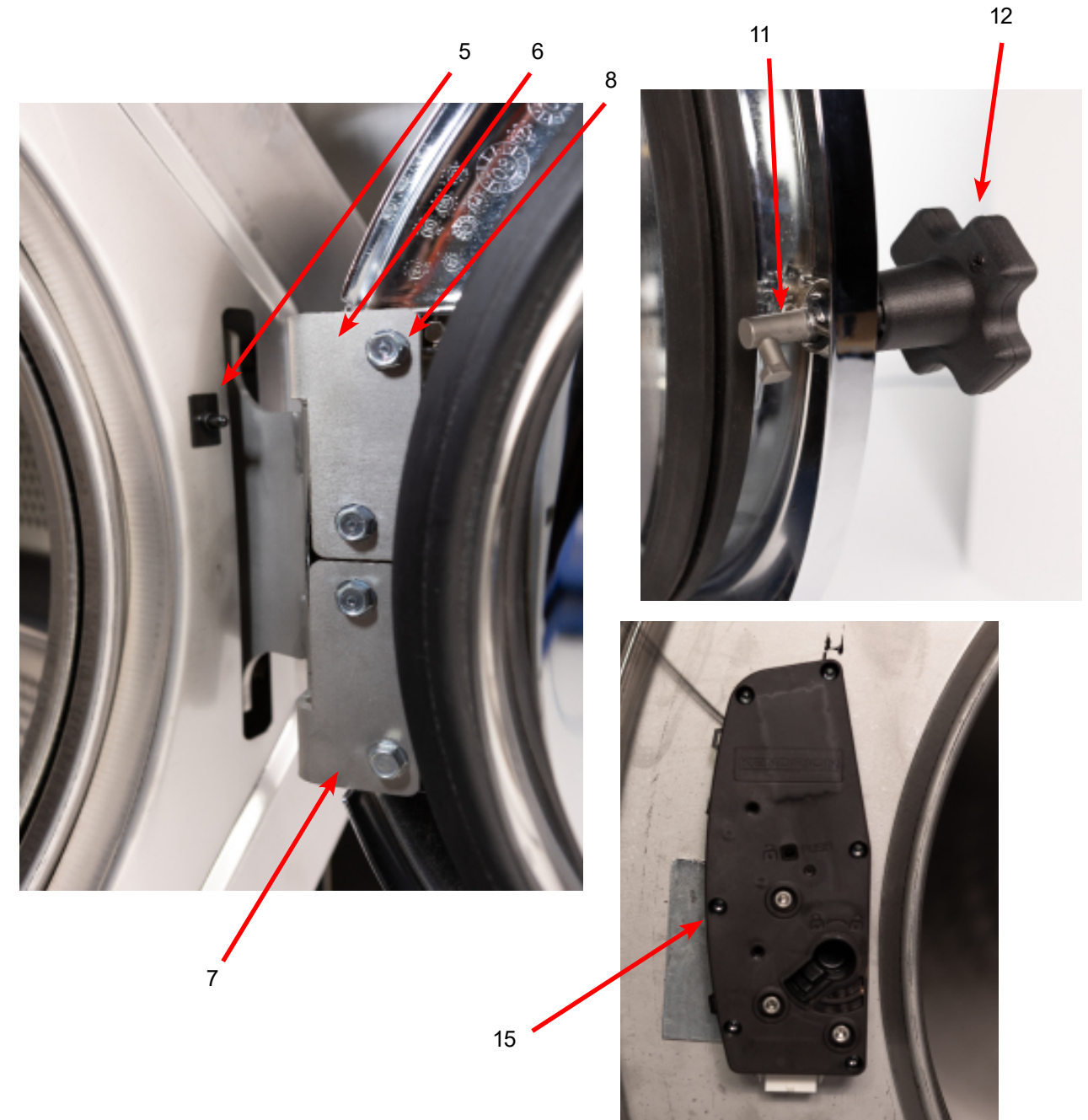

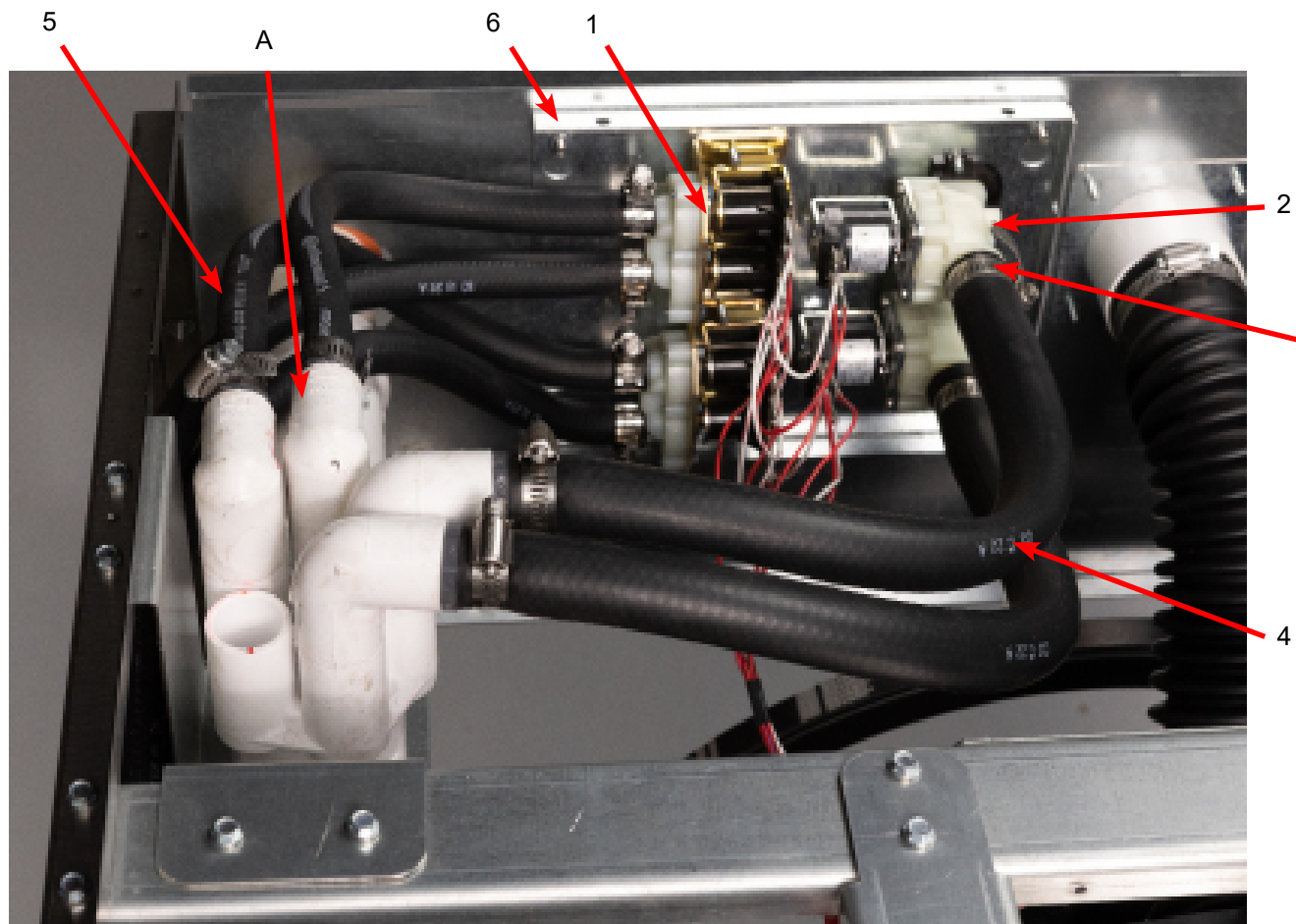

Water Inlet Parts Group

Key	Description	S-675	S-975	Qty
A	Injector Assembly	9883-017-001	9883-016-001	1
1	Valve, Water Inlet (dual outlet) (see Water Inlet Valve Break-down for individual parts)	9379-183-012	9379-183-012	2
*	Screw, Valve Mtg	9545-008-026	9545-008-026	4
2	Valve Water Inlet (single outlet)		9379-194-001	2
*	Screw, Valve M4x0.7x8mm		9545-064-001	4
3	Clamp-Water Valves	8654-117-015	8654-117-015	AR
*	Shield over Water Valves Plastic	9550-194-001	9550-195-001	1
*	Clip-Push	9083-121-001	9083-121-001	3
*	Flow resistor	9475-002-005	9475-002-005	4
4	1/2 inch hose, cut to length	9242-453-001	9242-453-001	AR
5	7/8 inch hose, cut to length		9242-466-001	AR
*	Clamp, Hose	9452-864-001	8654-117-017	2
6	Plate-Water Valves, Mounting		9452-862-001	1

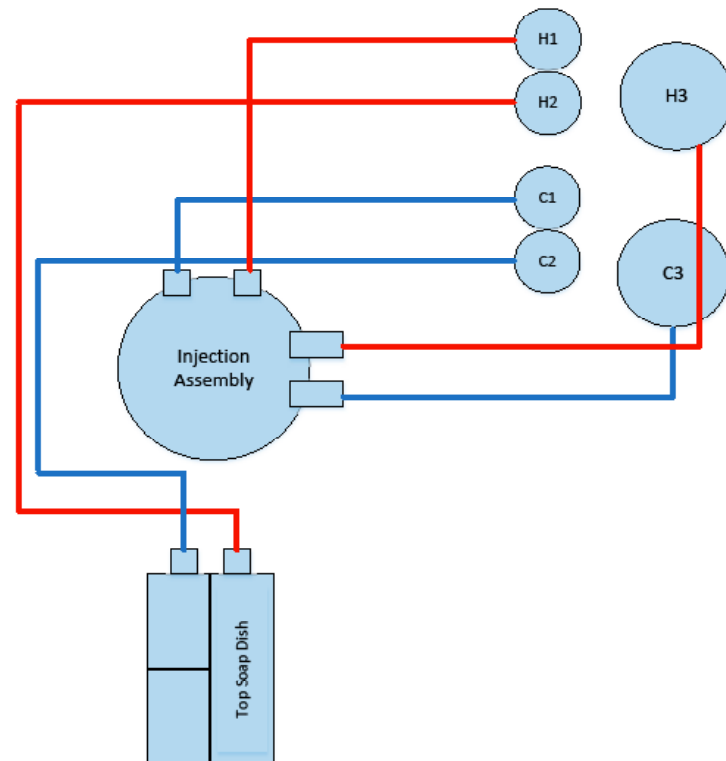

Water Inlet Valve Breakdown

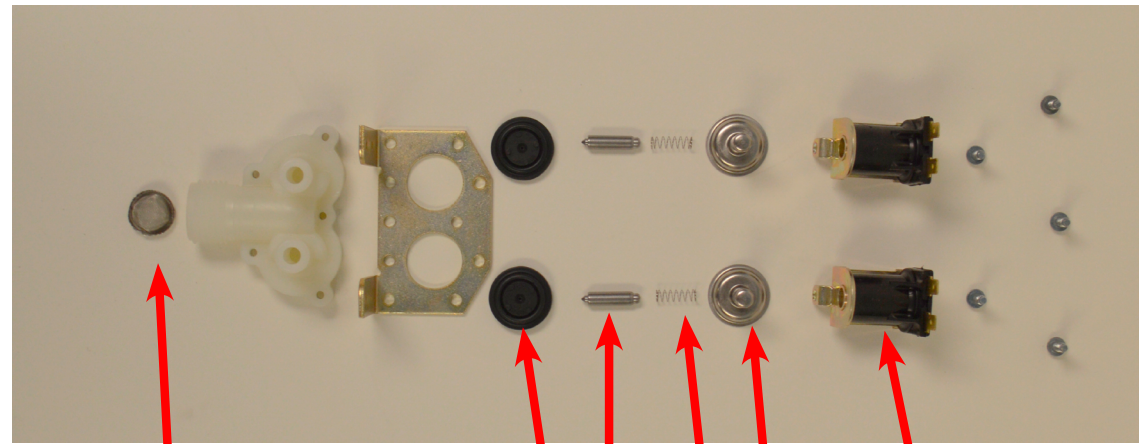

Key	Description	S-675	S-975	Qty
*	Valve, Water Inlet (includes 1 thru 6)	9379-183-012	9379-183-012	2
1	Screen, Inlet end of valve	9555-056-001	9555-056-001	2
2	Coil Assy., 120 V Invensys	9089-017-001	9089-017-001	2
*	Diaphragm Invensys (EPDM)	9118-049-001	9118-049-001	2
*	Diaphragm Invensys (Viton)	9118-049-002	9118-049-002	2
3	Diaphragm Invensys (EPDM NSF)	9118-049-003	9118-049-003	2
4	Guide, Solenoid Invensys	9211-021-002	9211-021-002	2
5	Armature Invensys	9015-008-001	9015-008-001	2
6	Spring, Armature Invensys	9534-298-001	9534-298-001	2

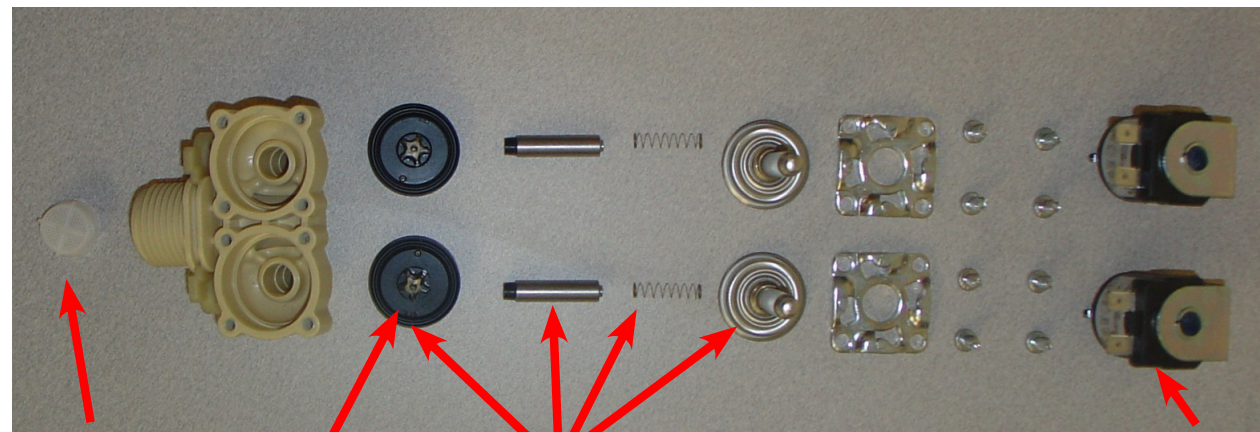

Optional Water Valve

Key	Description	S-675	S-975	QTY
*	Dual Coil Water Valve Mueller	9379-192-001	9379-192-001	1
7	Valve Water Body Complete(no coil)	9379-192-002	9379-192-002	1
8	Diaphragm Mueller	9118-054-001	9118-054-001	2
9	Filter Mueller	9183-046-001	9183-046-001	2
10	Coil Mueller	9089-051-001	9089-051-001	2
11	Diaphragm Assembly Mueller Includes	9785-001-001	9785-001-001	2

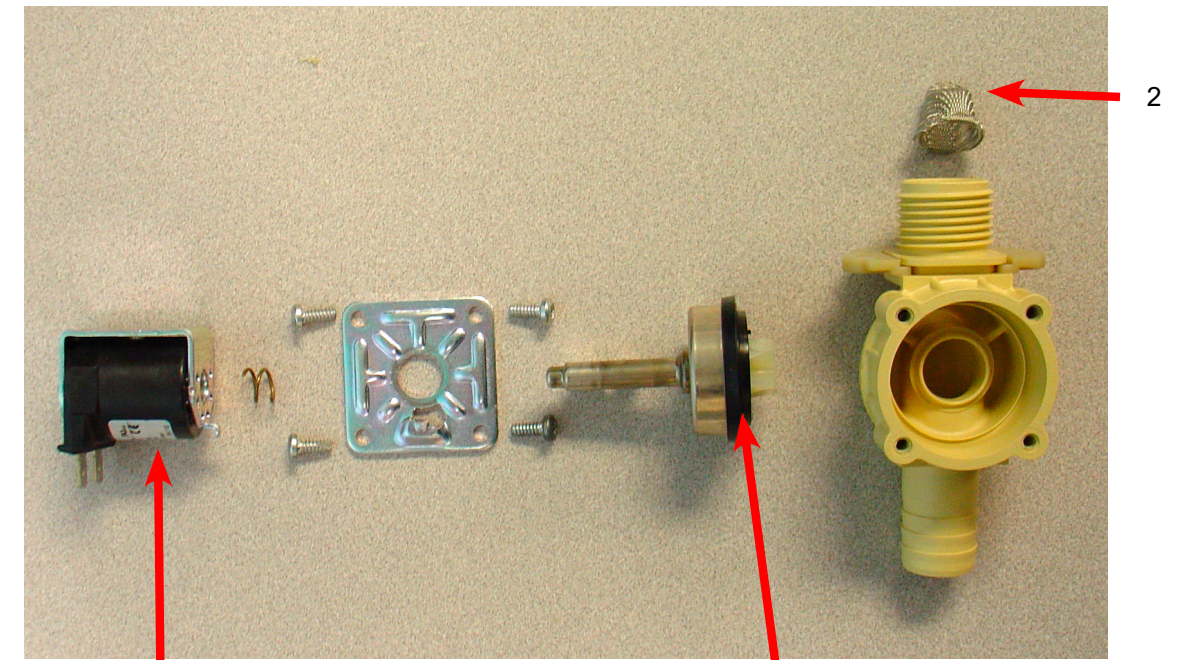

Key	Description	S-675	S-975	QTY
*	Single Coil Water Valve Mueller		9379-194-001	1
1	Diaphragm Mueller		9118-055-001	1
2	Filter Mueller		9183-046-001	1
3	Coil Mueller		9089-051-001	1

Rear Channel Parts Group

	Description	S-675	S-975	Qty
1	Channel Assembly Rear	9947-063-001	9947-058-001	1
2	Screw #10Bx1/2	9545-008-026	9545-008-026	6
*	Nut, Expansion	8640-442-001	8640-442-001	6
3	Plug, 7/8"	9456-041-006	9456-041-006	1
4	Bushing, 7/8"	9053-067-002	9053-067-002	1
5	Bracket-Terminal Block Assy	9029-326-001	9029-326-001	1
6	Screw #10Bx1/2	9545-008-026	9545-008-026	4
7	Strip-Terminal marker, Power	9558-025-001	9558-025-001	1
8	Terminal Block-Power	9897-033-002	9897-033-002	1
*	Screw-6ABx3/4	9545-031-001	9545-031-001	2
9	Harness-Power Terminal Block	9627-932-003	9627-932-003	1
10	Terminal Lug, Solderless	8652-134-001	8652-134-001	1
*	Lockwasher-Exttooth, #10	8641-582-006	8641-582-006	1
*	Screw-10-32ttX1x1/2Grn	9545-008-027	9545-008-027	1
11	Strip-Terminal Marking, Injector	9558-036-001	9558-036-001	1
12	Terminal Block-Injector	9897-032-003	9897-032-003	1
*	Screw-4Bx5/8ss	9545-053-002	9545-053-002	2
13	Harness-Injection	9627-935-003	9627-935-003	1
14	Label-Warning	8502-639-001	8502-639-001	1
15	Bushing-Insulated, 3/4"	9053-067-001	9053-067-001	1
16	Bushing-Insulated, 1"	9053-067-004	9053-067-004	1
*	Cover, Terminal Block	9074-267-001	9074-267-001	1
*	Screw #10Bx1/2	9545-008-026	9545-008-026	1
17	Plate-Drive mounting	9452-848-001	9452-848-001	1
18	Nut, #10-32UNF, 2B	8640-413-002	8640-413-002	4
19	VFD	9375-037-008	9375-037-007	1
*	VFD Cooling Fan	9189-017-001	9189-017-001	1
20	Nut, #10-32UNF, 2B		8640-848-001	4
*	Cable, Data	9806-023-005	9806-023-005	1
21	Plate-Water Valves, Mounting	9452-864-001	9452-862-001	1
22	Nut, #10-32UNF, 2B	8640-413-002	8640-413-002	4
23	Valve-Water, Duel Coil	9379-183-012	9379-183-012	2
*	Screw #10Bx1/2	9545-008-026	9545-008-026	4
24	Water-Valve, Single Coil		9379-194-001	2
25	Screw-Phillips, 4mx0.7x8mm		9545-064-001	4
*	Shield, Water Valves	9550-194-001	9550-195-001	1
*	Clip-Push	9083-121-001	9083-121-001	3
26	Cap-Injector Assy	0935-127-001	0935-127-001	1
27	Clamp	8654-117-015	8654-117-017	2
28	Hose-Suds Overflow	9242-474-001	9242-474-001	1
29	Resistors (160 Ohm)	9483-004-003	9483-004-003	2
*	Screws (Mounting)	9545-045-002	9545-045-002	3
30	Jumper Wires	8220-117-002	8220-117-002	2
*	Screw-#6-32x5/16	9545-044-006	9545-044-006	4
*	Nut-#6-32	8640-411-003	8640-411-003	4

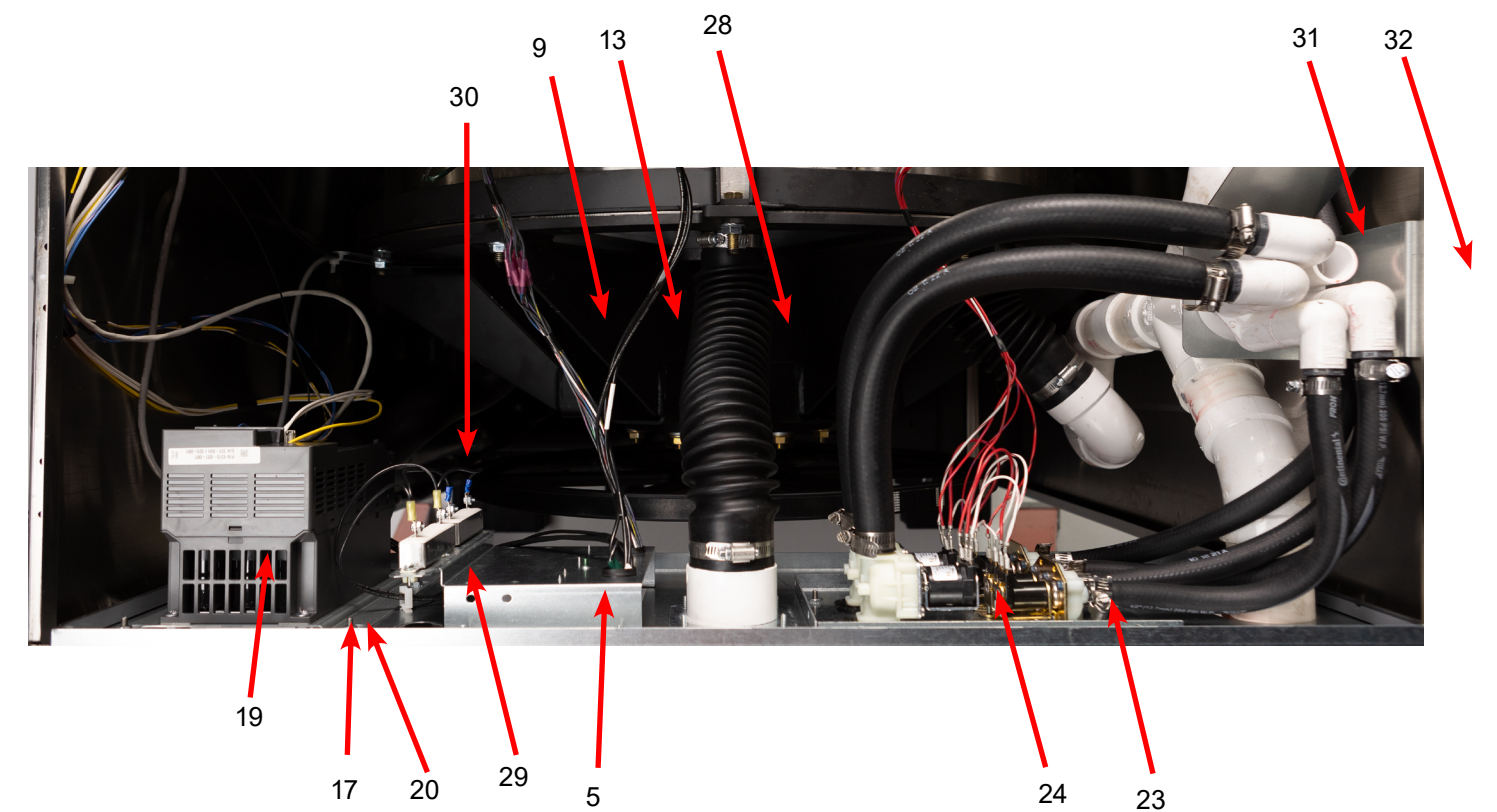
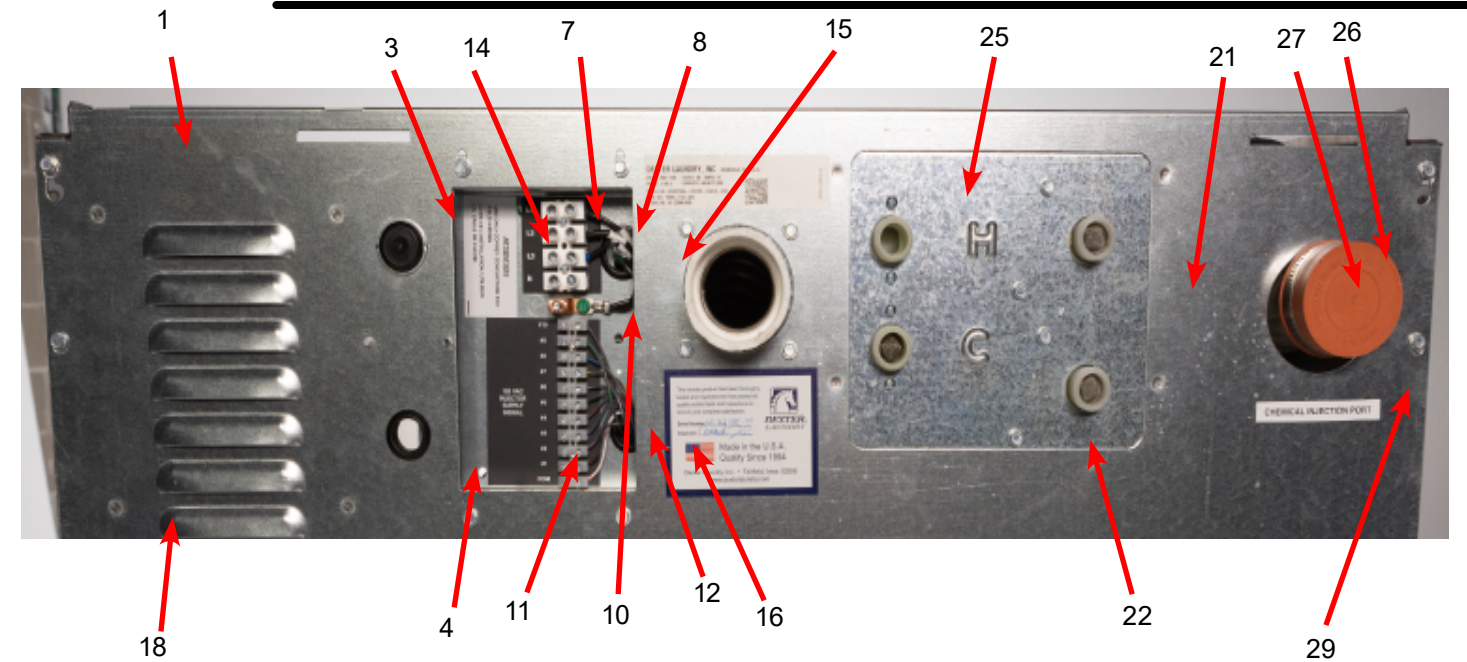

Key	Description	S-675	S-975	Qty
31	Injection assy	9883-017-001	9883-016-001	1
32	Bracket-Injector Assy	9029-352-001	9029-346-001	1
*	Screw, 10Bx1/2	9545-008-026	9545-008-026	4

Cradle & Base Parts Group

Key	Description	S-675	S-975	Qty
*	Cradle Assembly	9967-011-001	9967-010-001	1
*	Base Assembly	9945-161-001	9945-160-001	1
*	Leveling Shim	9552-052-001	9552-052-001	AR
*	Channel Assembly-Base, Front/Rear	9947-060-002	9947-057-002	2
1	Channel-Base, Front/Rear	9081-211-001	9081-201-001	2
*	Plate-Base, Foot	9452-859-001	9452-859-001	4
*	Channel-Base, Middle	9081-212-002	9081-202-002	1
2	Channel Assembly-Base (RH/LH)	9947-061-001	9947-056-001	2
*	Nut-Rivet, SS, Hex,1/4-20	8640-438-001	8640-438-001	8
3	Screw-3/8-16x3/4	9545-029-015	9545-029-015	20
4	Nut-Hex 3/8-16	8640-415-004	8640-415-004	20
*	Pad-Spring Rightwind	9455-067-001	9455-067-001	4
*	Spring-Compress, Right (Gray)	9534-368-001	9534-368-001	2
5	Pad-Spring Leftwind	9455-067-002	9455-067-002	4
6	Spring-Compress, Left (Black)	9534-368-002	9534-368-002	2
*	Spring Replacement Kit	9732-364-001	9732-364-001	
7	Screw-1/4Bx3/4	9545-030-002		16
7	Screw-1/4Bx3/4		9545-030-002	8
*	Plate-Spacer, Spring		9452-860-002	2
8	Bracket-Damper, Base	9029-337-002	9029-337-002	4
9	Screw-1/4Bx1 1/4		9545-030-003	8
10	Cradle-Side, Right	9085-010-001	9085-009-001	1
*	Cradle-Side, Left	9085-010-002	9085-009-002	1
*	Support Assembly-Front Cradle	9991-079-002	9991-077-002	2
*	Support-Front/Middle Cradle	9548-295-001	9548-293-001	2
*	Pad-Tub Cradle	9455-070-001	9455-069-001	2
*	Support-Rear Cradle	9548-296-002	9548-294-002	1
11	Clamp Assembly-Tub Band, Male	9938-042-001	9938-041-001	2
12	Clamp Assembly-Tub Band, Female	9938-042-002	9938-041-002	2
13	Bracket-Damper, Rear Cradle	9029-355-002	9029-338-002	2
14	Bracket-Damper, Front Cradle	9029-356-002	9029-339-002	2
15	Plate-Counter Weight	9452-863-002	9452-861-002	10
*	Brace-Counter Weight	9046-103-002	9046-100-002	1
16	Damper	9125-010-001		6
16	Damper		9125-010-001	12
*	Damper Replacement Kit	9732-363-002	9732-363-001	
17	Screw-3/8-16x3/4	9545-029-015	9545-029-015	48
18	Screw-3/8-16x1 1/2	9545-029-016		16
18	Screw-3/8-16x1 1/2		9545-029-016	24
19	Nut-3/8-16	8640-415-004		64
19	Nut-3/8-16		8640-415-004	72
*	Screw-1/4Bx3/4	9545-030-002	9545-030-002	16
*	Washer, Interlocking 1/2	8641-591-001	8641-591-001	16
20	Bolt-1/2-13x6 1/2	9545-017-020	9545-017-020	8
21	Nut-Hex 1/2-13	8640-417-002	8640-417-002	8

NOTE: Interlocking Washers are ONE-time use.

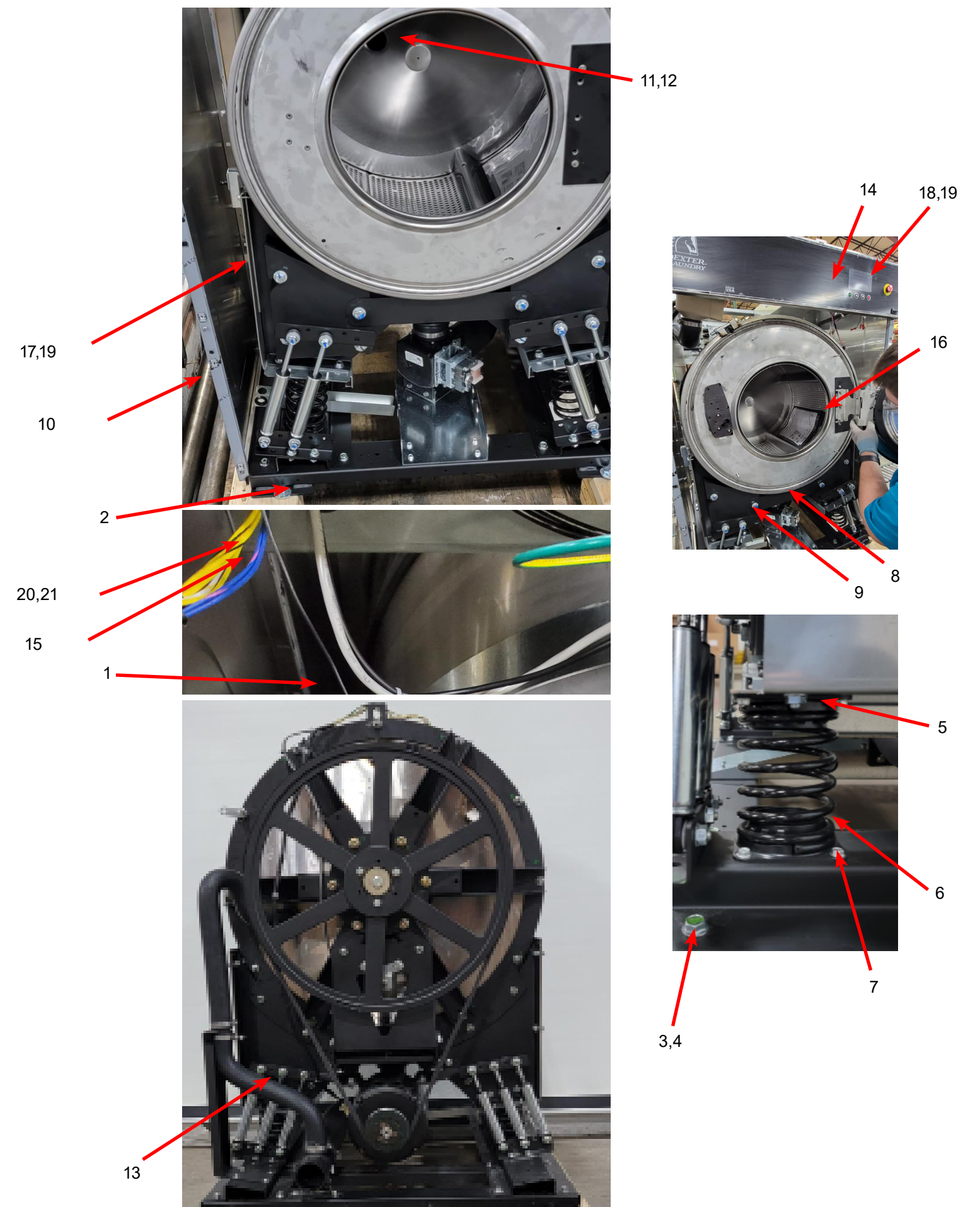

Notes

Drain Valve Parts Group

Key	Description	Part Number	Qty
1	Valve, Drain (includes #2 thru #11)	9379-204-001	1
2	Motor & Gear Train Assy 115v	9914-137-023	1
3	Spring, Drive	9534-339-001	1
*	Seal, V Packer	9532-134-001	1
*	Pin, Main Drive	9451-196-001	1
*	Kit - Seal Replacement	9732-327-001	1

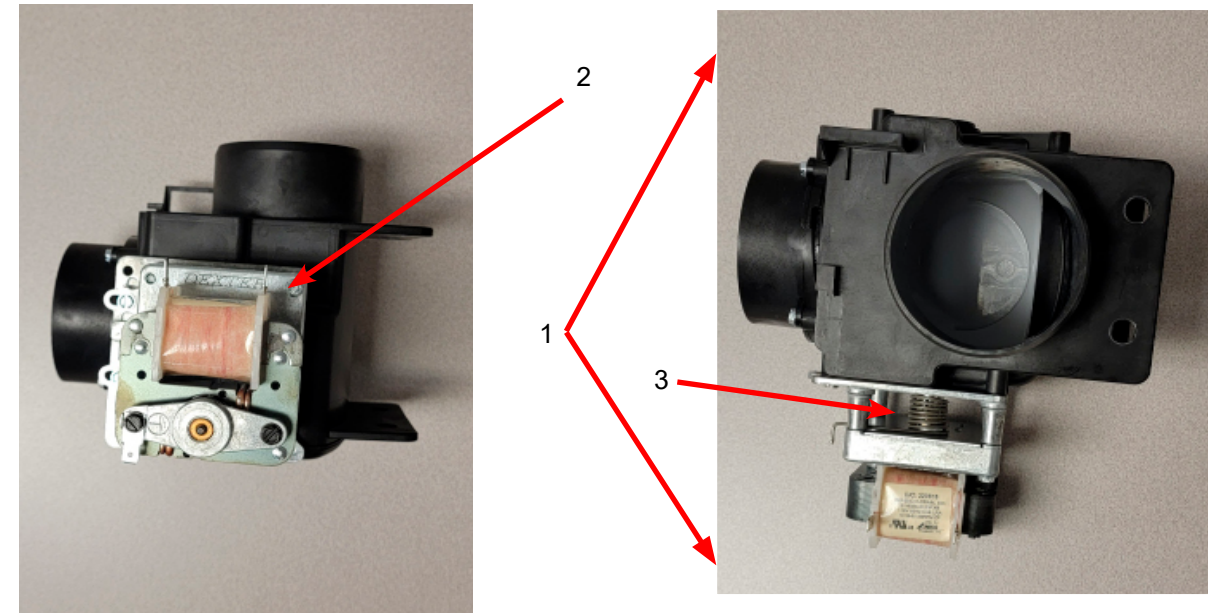

Chassis and Drain Parts Group

Key	Description	S-675	S-975	Qty
1	Outer Tub Assy.	9930-189-001	9930-188-001	1
2	Tub & Cylinder Assy.	9869-048-001	9989-047-001	1
*	Tub Front	9974-024-001	9974-022-001	1
*	Gasket, Tub Front	9206-421-004	9206-421-002	1
3	Ring Assy, Tub Mtg-Front Clamp	9950-063-001	9950-055-001	1
4	Bolt, Top Front Ring 3/8"-16 x 3"	9545-029-009	9545-029-009	1
*	Nut 3/8"-16	8640-415-001	8640-415-001	1
*	Lockwasher-Spring 3/8	8641-582-003	8641-582-003	1
5	Hose, Tub to Drain Valve	9242-469-001	9242-469-001	1
6	Clamp, Hose (Tub to Drain Valve)	8654-117-014	8654-117-014	2
7	Valve, Drain	9379-204-001	9379-204-001	1
*	Screw, Valve to Bracket 1/4-20x1/2	9545-018-013	9545-018-013	4
8	Hose, Drain Valve to Tube	9242-476-001	9242-470-001	1
*	Clamp, Hose (Drain Valve to Tube)	8654-117-014	8654-117-014	2
9	Tube Assy, Drain	9915-134-002	9915-134-002	1
*	Bracket, Drain Tube	9029-347-001	9029-347-001	1
*	Screw Tube (Bracket to Base 1/4Bx3/4)	9545-030-002	9545-030-002	2
10	Hose-Overflow Upper	9242-477-001	9242-471-001	1
11	Tube Assy-Overflow	9915-136-002	9915-136-002	1
12	Hose-Overflow Lower	9242-475-001	9242-475-001	1
*	Clamp-Hose Over Flow	8654-117-014	8654-117-014	4
*	Bracket-Overflow Hose	9029-351-001	9029-351-001	1
*	Hose, Pressure switch	9574-175-009	9242-175-009	1
*	Clamp, Hose	8654-117-015	8654-117-015	1
*	Bracket-switch,prox	9029-308-001	9029-375-001	1
*	Washer-flat	8641-581-032	8641-581-043	1
*	Screw-hxcap,5/8-11x1 1/2	9545-060-001	9545-060-001	1
13	Switch-prox,18mm,shld,60"	9539-498-001	9539-498-001	1
14	Sensorassembly-thermistor,10k	9501-005-002	9501-005-002	1
*	Sealer-pipe	8538-132-001	8538-132-000	AR

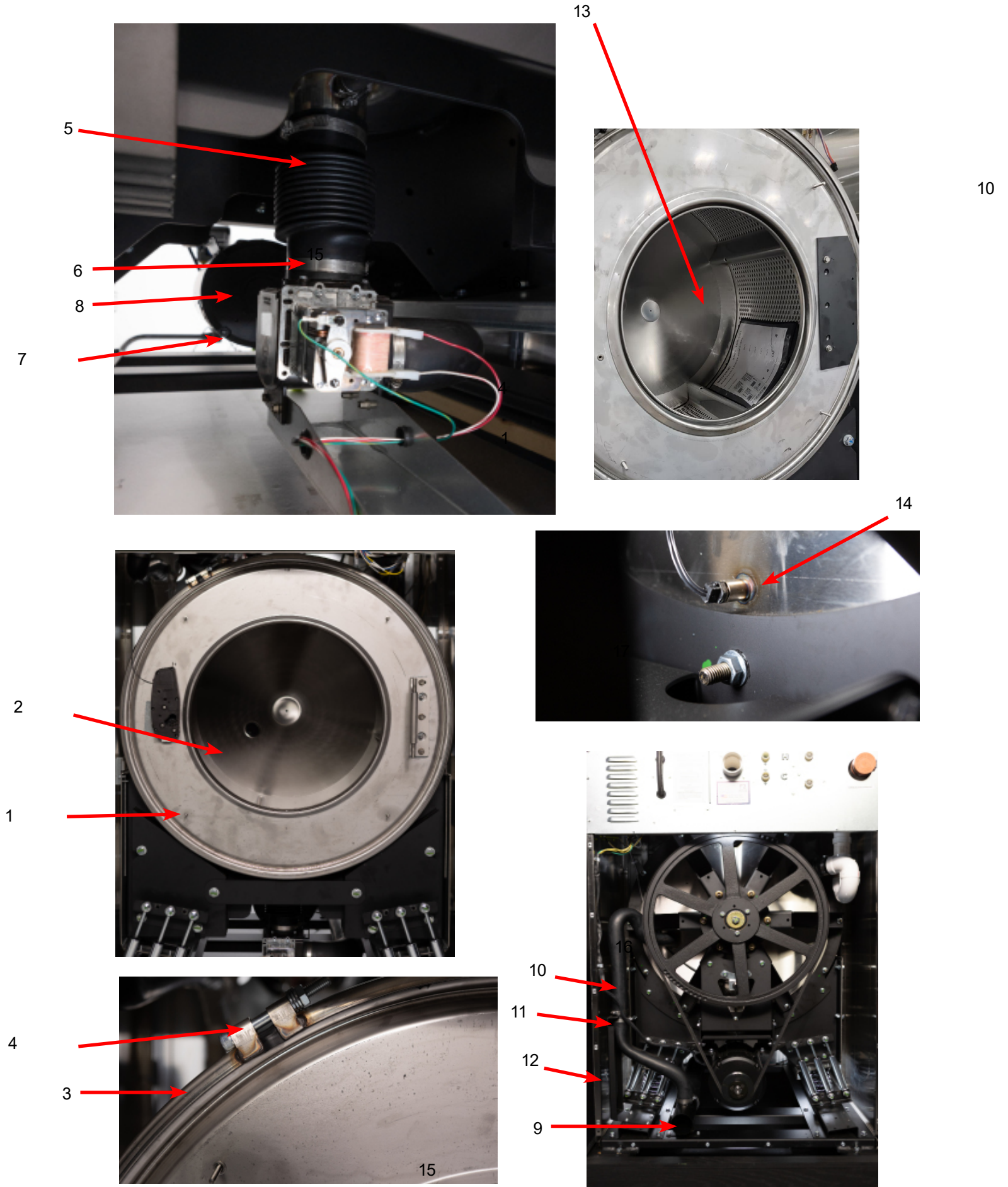

Electrical Components - Top Compartment

Key	Description	S-675	S-975	Qty
*	Contrlrassy-trgh, opl,60hz	9857-280-001	9857-279-001	1
1	Troughassy-control	9575-044-001	9575-044-001	1
2	Transformer-dualsecondary	8711-017-001	8711-017-001	1
*	Screw-hxwshrhnduct,#10bx1/2	9545-008-026	9545-008-026	4
*	Lockwasher #10	8641-582-006	8641-582-006	4
3	Terminalblockassembly-power	9897-044-001	9897-044-001	1
*	Screw-panhdcr,#8abx1/2	9545-045-012	9545-045-012	4
*	Wiringharness-ctrl,graph,can,wshr	9627-922-002	9627-922-002	1
4	Pcbassy-maincontrol	9799-029-001	9799-029-001	1
5	Pcbassy-relay	9799-028-001	9474-004-001	2
*	Screw-hxwshrhnduct,#10bx1/2	9545-008-026	9545-008-026	10
6	Wiringharness-main	9628-010-001	9628-010-001	1
7	Wiringharness-chemical,v2.0wshr	9627-927-001	9627-927-001	1
8	Wireasy,2.0, Model Jumper	8220-158-034	8220-158-035	1
*	Wiringharness-drsw/vfd,stp	9627-928-004	9627-928-004	1
*	Clamp-cable,3/16"	8654-125-005	8654-125-005	4
9	Wiringharness-cntrl/relay,v2.0	9627-921-001	9627-921-001	2
*	Wireasy-jumper,v2.0,relaypcb	8220-159-005	8220-159-005	1
*	Wireasy-jumper,v2.0,relaypcb	8220-159-006	8220-159-006	1
*	Screw-hxwshrhds1,10-32tx1/2 grn	9545-008-027	9545-008-027	1
*	Lockwasher #10	8641-582-006	8641-582-006	1
*	Standoff-twistlok	9527-007-001	9527-007-001	10
10	Sensorassy-wps	9474-007-001	9474-007-001	1
*	Support-pcb,3/8",edge Holding	9548-292-001	9548-292-001	1
11	Wiringharness-wps/thermo	9628-017-001	9628-017-001	1
*	Wireasy-org 17"	8220-062-052	8220-062-052	1
*	Wireasy-wht/org,17 1/2"	8220-062-053	8220-062-053	1
12	Fuse-2a,slow,1/4x1-1/4 (on the 24V)	8636-018-005	8636-018-005	1
13	Fuse-1.5a,fast,1/4x1-1/4 (on the 120V)	8636-018-001	8636-018-001	1
14	Elecperiph-powersupply,12v	9628-012-001	9628-012-001	1
*	Wiringharness-drkrelay	9628-013-001	9628-013-001	1
15	Wiringharness-rebal, input	9628-014-001	9628-014-001	1
*	Wiringharness-maxdispsto	9628-015-001	9628-015-001	1
*	Channel-trough, front	9081-215-001	9081-206-001	1
*	Channel-trough, rear	9081-216-001	9081-208-001	1
*	Channel-trough, front to back	9081-207-001	9081-207-001	1
16	24v Relay	5192-285-004	5192-285-004	1
17	120v Relay	5192-285-001	5192-285-001	1
18	Data Cable	9806-023-005	9806-023-005	1
*	Wiringharness-15 pin, noinj	9628-011-001	9628-011-001	1

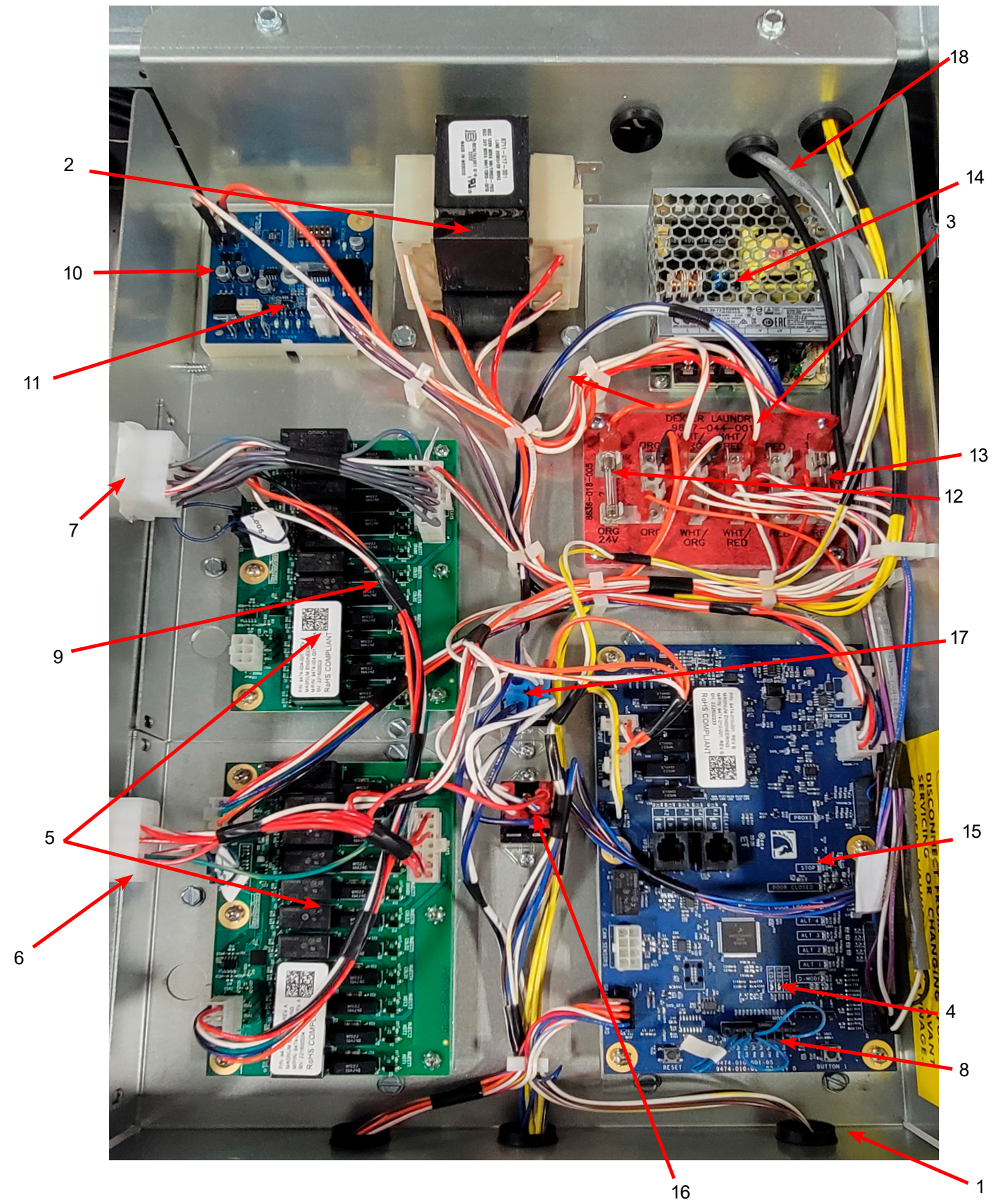

Key	Description	S-675	S-975	Qty
1	Panel Control Assembly(panel only)	9444-085-001	9444-078-001	1
*	Plate -Latch, Top	9452-625-001	9452-625-001	2
*	Nut Hexkeps #8-32	8640-412-005	8640-412-005	4
*	Screw-FillHDCR 10Bx9/16	9545-008-023	9545-008-023	1
2	Button-control,2.0,opl	9035-063-001	9035-063-001	1
3	Window-display,lcd(w/gasket)	9635-021-002	9635-021-002	1
4	Contrlassy-display,2.0,opl,wsh	9857-230-003	9857-230-003	1
*	Nut-hexkeps,#6-32	8640-411-003	8640-411-003	4
5	Cableassy-usb,snapi	9806-024-001	9806-024-001	1
6	Button-emergencystop,w/latch	9035-061-002	9035-061-002	1
*	Spacer-pcb,#8x1/8	9538-157-005	9538-157-005	2
7	Plate-mounting,stopbutton	9452-725-001	9452-725-001	1
*	Nut-hexkeps,#8-32	8640-412-005	8640-412-005	2
8	Switch-contactblock,dpst,nc	9539-499-001	9539-499-001	1
*	Nameplate,Control Panel (one piece) Black	9412-263-001	9412-262-001	1
*	Screw, #10B x 1/2	9545-008-026	9545-008-026	6

Control Panel Parts Group

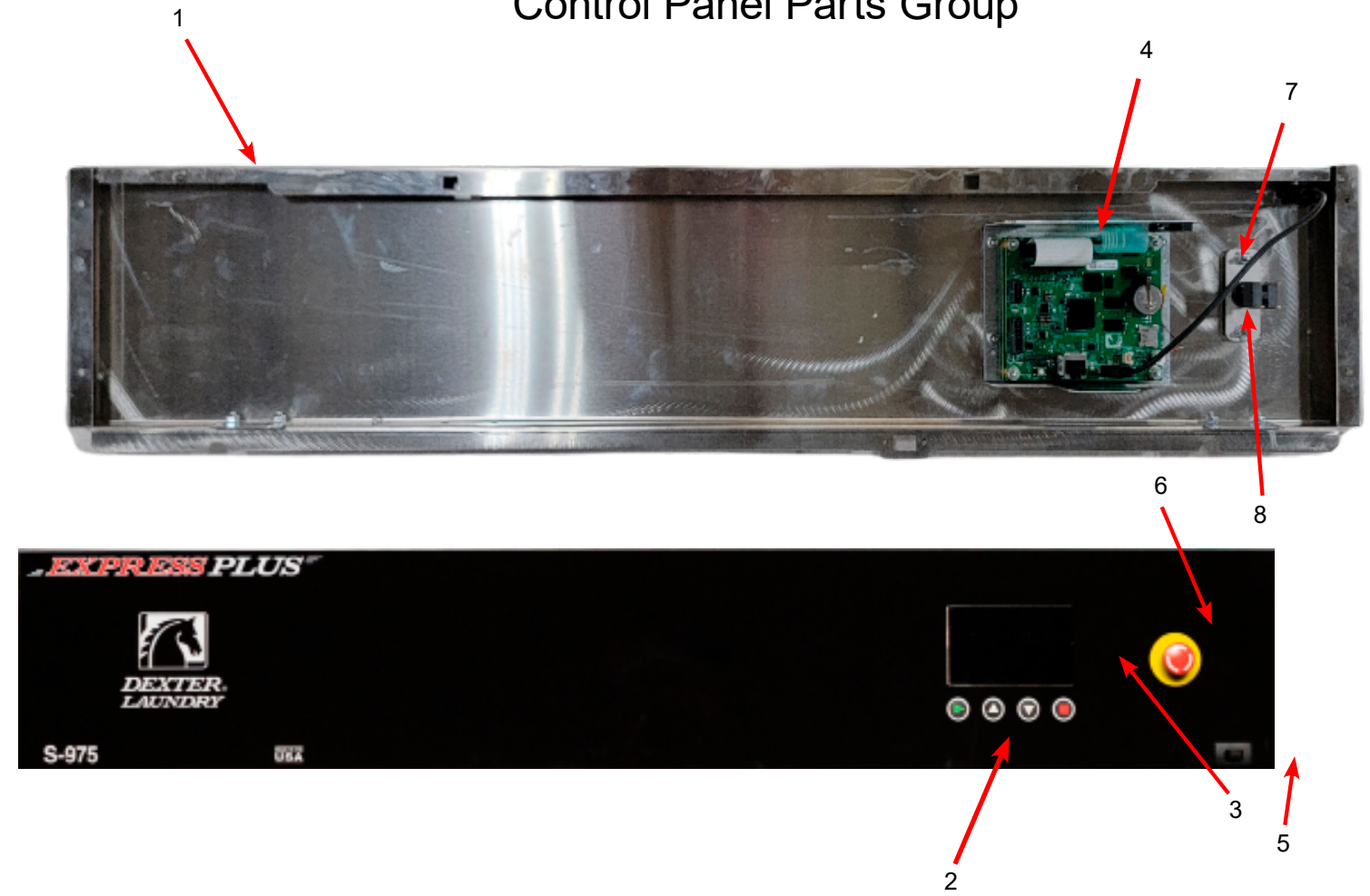

Soft Mount O-Series -39 Models

WS0675XA-39XO 230 Volts 50 Hz Single Phase
 WS0975XA-39XO 230 Volts 50 Hz Single Phase

Key	Description	S-675	S-975	QTY
1	Circuit breaker	5198-211-002	5198-211-002	1
*	Instructions, Transformer Control	8507-449-002	8507-449-002	1
*	Operators Manual	8514-305-001	8514-305-001	1
2	Control Transformer, 200/250-24V 50Hz	8711-004-004	8711-004-004	1
3	Water Valve	9379-183-013	9379-183-013	2
4	Water Valve, Single	9379-194-003	9379-194-003	2
*	Input Power Terminal Block Assembly	9897-045-002	9897-045-002	1
*	Wiring Label, Schematic	9508-094-001	9508-094-001	1
*	Rear Channel Assembly	9947-063-002	9947-059-002	1
*	Wiring Harness, Power Terminal Block	9628-001-003	9628-001-003	1
*	Wiring Harness, Main	9628-026-001	9628-026-001	1
*	Wiring Harness, Injection	9628-003-001	9628-003-001	1
*	Wiring Harness, 15-pin non inj.	9628-027-001	9628-027-001	1
*	Control Trough Only	9857-280-002	9857-279-002	1

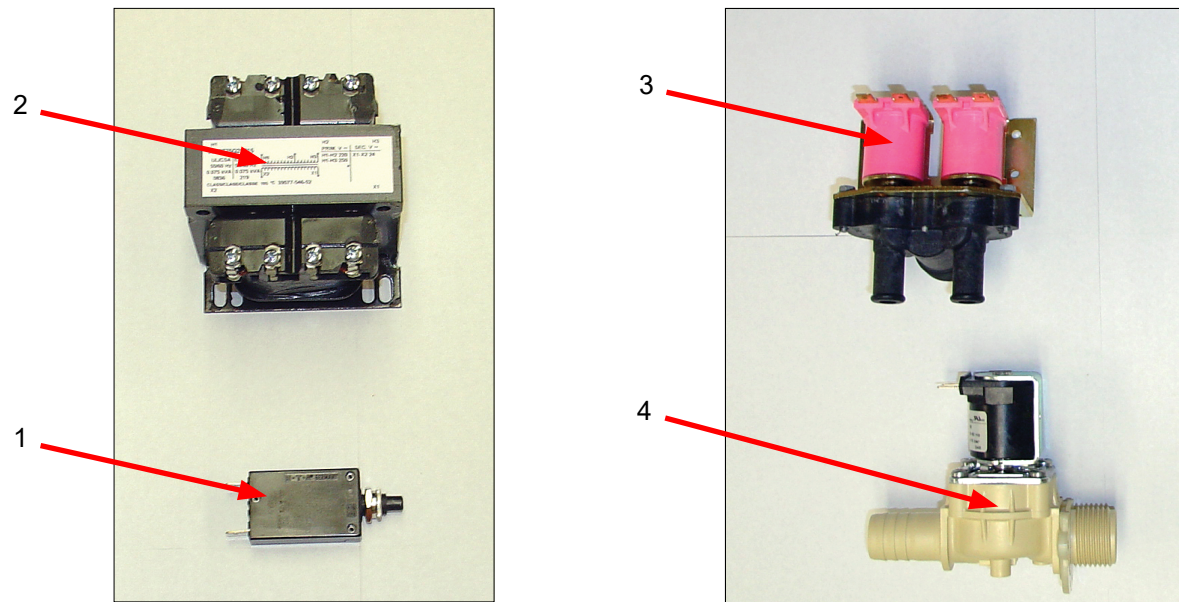

Drain Valve Parts Group

Key	Description	Part Number	Qty
1	Valve, Drain (includes #2 thru #11)	9379-204-002	1
2	Motor & Gear Train Assy 115v	9914-137-022	1
3	Spring, Drive	9534-339-001	1
*	Seal, V Packer	9532-134-001	1
*	Pin, Main Drive	9451-196-001	1
*	Kit - Seal Replacement	9732-327-001	1

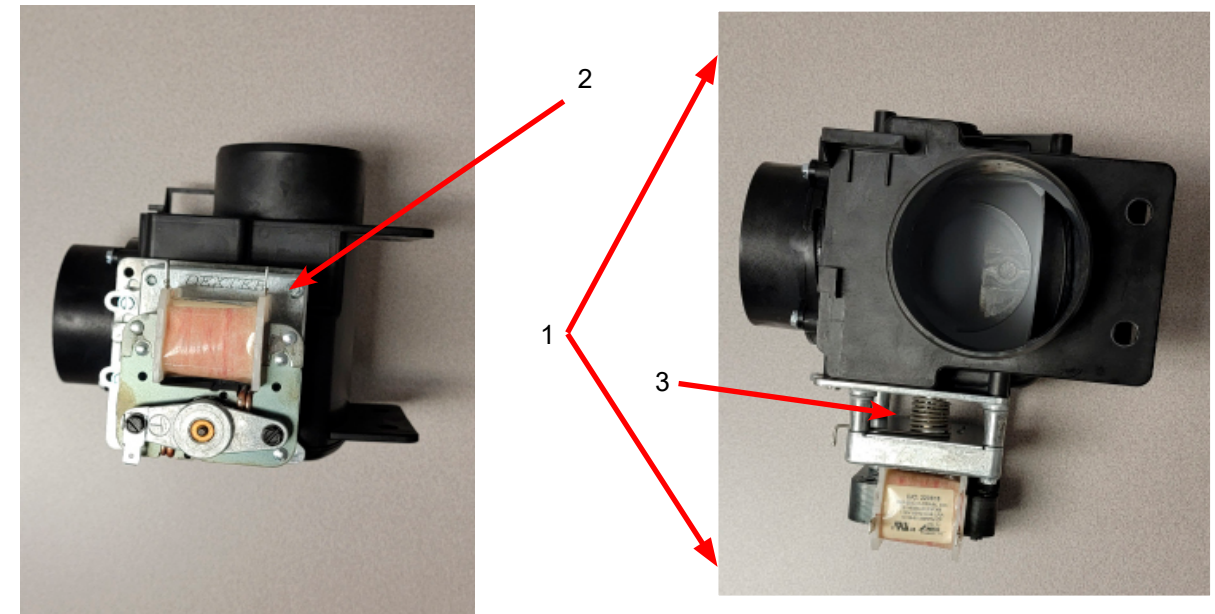

WS0975XB-39EO Schematic

WS0975XB-39EO Diagram

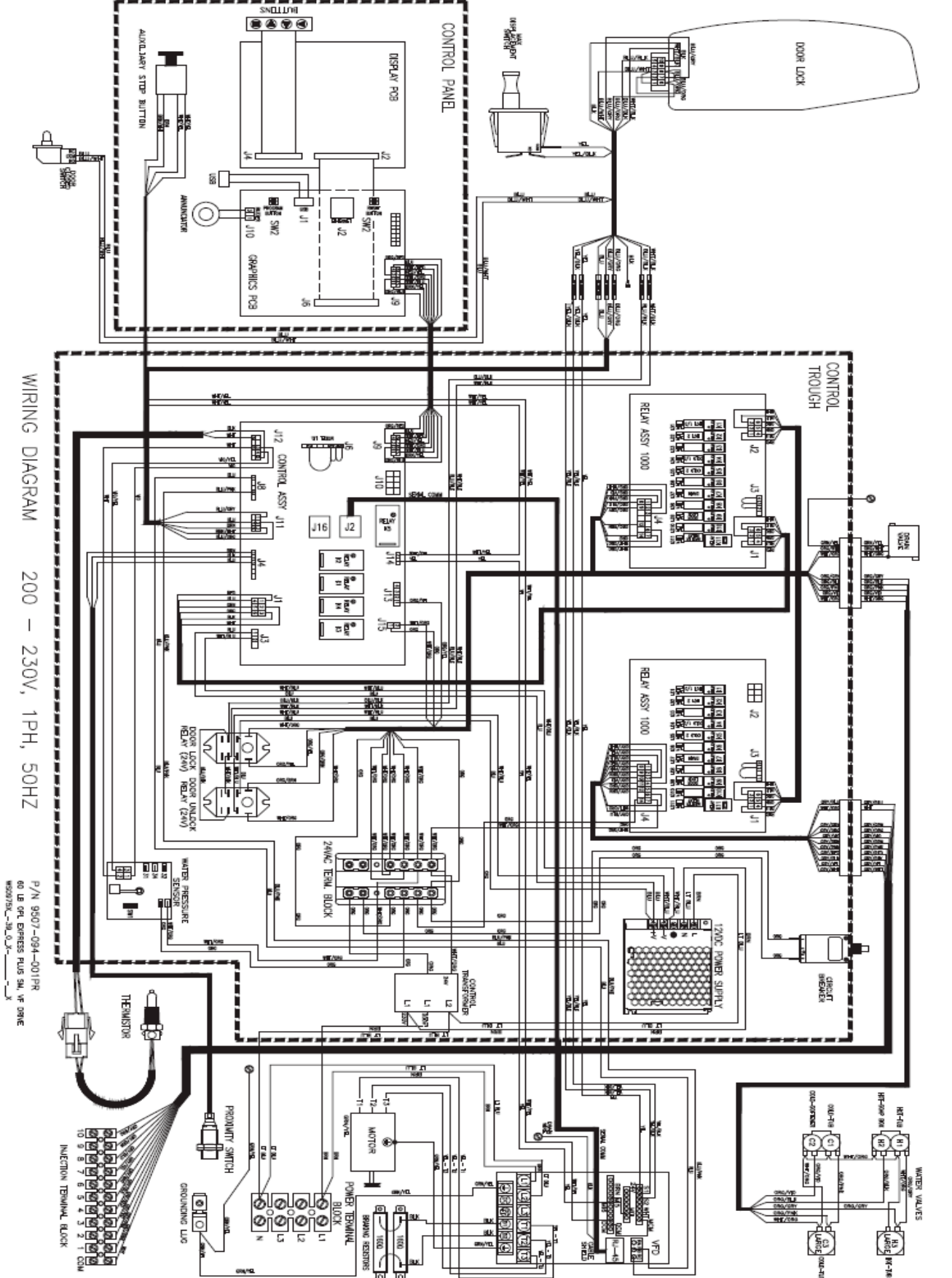
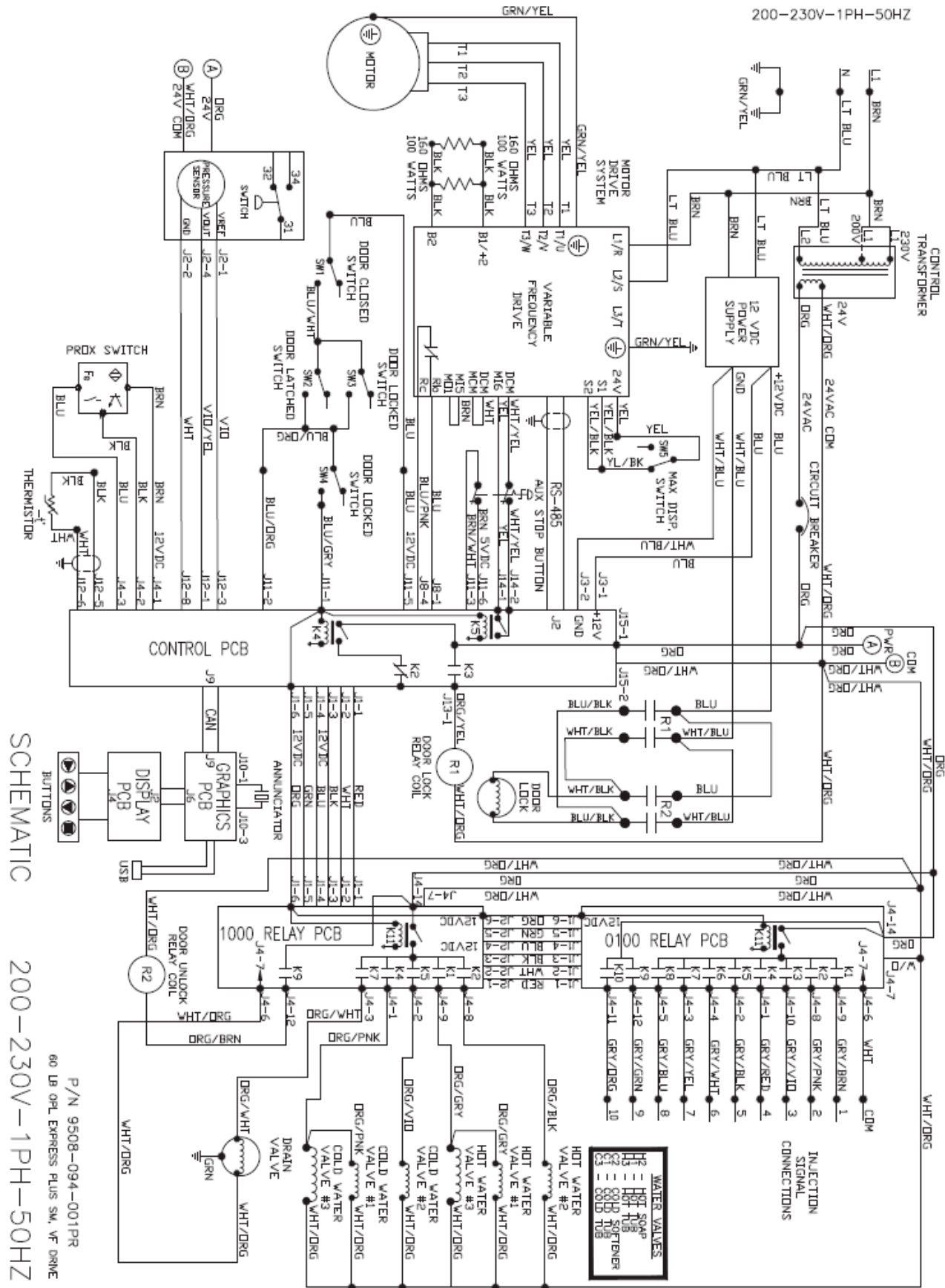



Section 10: Maintenance

Preventative Maintenance

DAILY

- Check that the loading door remains securely locked and cannot be opened during an entire cycle.
- Clean the top, front, and sides of the cabinet to remove residue.
- Clean the soap dispenser and lid and check that all dispenser mounting screws are in-place and tight.
- Check the loading door for leaks. Clean the door seal of all foreign matter.
- Leave the loading door open to aerate the washer when not in use.

QUARTERLY

- Make sure the washer is inoperative by switching off the main power supply.
- Check the suspension springs and dampers for wear. Retighten bolts if necessary.
- Check the V-belts for wear and proper tension.
- Clean lint and other foreign matter from around motor.
- Check all water connections for leaks.
- Check the drain valve for leaking and that it opens properly.
- Wipe and clean the inside of the washer and check that all electrical components are free of moisture and dust.
- Remove and clean water inlet hose filters. Replace if necessary.
- Check anchor bolts (if used). Retighten if necessary.

IMPORTANT: Replace all panels that were removed to perform daily and/or quarterly maintenance.