



DEXTER[®]
LAUNDRY

**USE THE BLUE TABS LOCATED ON THE
RIGHT AND LEFT SIDES OF THE FOLLOWING
DOCUMENT TO ADVANCE TO EACH SECTION.**



DEXTER
LAUNDRY



Industrial OPL Stack Dryer 50 Pound Reversing Stacked Dryer

Service and Parts Data

Equipment Safety Warnings Symbols and Terminology Used in this Equipment

	<p>DANGER</p> <p>Indicates an imminently hazardous situation, which if not avoided, will result in death or serious injury.</p>
	<p>WARNING</p> <p>Indicates a potentially hazardous situation, which if not avoided could result in death or serious injury.</p>
	<p>CAUTION</p> <p>Indicates a potentially hazardous situation which, if not avoided, may result in minor or moderate injury. It may also be used to alert against unsafe practices. Minor burns, pinch points that result in bruises and minor chemical irritation.</p>
	<p>NOTICE</p> <p>Indicates information or a company policy that relates directly or indirectly to the safety of personnel or protection of property.</p>
	<p>This is the user caution symbol. It indicates a condition where damage to the equipment resulting in injury to the operator could occur if operational procedures are not followed. TO REDUCE THE RISK OF DAMAGE OR INJURY, refer to accompanying documents; follow all steps or procedures as instructed.</p>
	<p>This is the electrical hazard symbol. It indicates that there are DANGEROUS HIGH VOLTAGES PRESENT inside the enclosure of this product. TO REDUCE THE RISK OF FIRE OR ELECTRIC SHOCK, do not attempt to open the enclosure or gain access to areas where you are not instructed to do so. REFER SERVICING TO QUALIFIED SERVICE PERSONNEL ONLY</p>
	<p>Caution! There are sharp edges on various sheet metal parts internal to the enclosure. Use safety consciousness when placing or moving your hands while working in the interior of this equipment.</p>
	<p>Caution! To reduce the risk of damage to the Water Inlet Valve, do not supply inlet water with a temperature that exceeds 70° C.</p>
	<p>Caution! To reduce the risk of fire or explosion, do not operate this equipment in any hazardous classified (ATEX) environment.</p>

Equipment Safety Warnings

Symbols and Terminology Used in this Equipment



Warning! Do not operate equipment if door glass is damaged in any way.



Warning! Keep clear of rotating parts.



Prohibited! Do not enter this equipment or space.



Prohibited! Do not step or stand on this equipment.



Prohibited! Do not operate without all guards and covers in place.









Prohibited! Do not operate without all guards and covers in place.



Prohibited! Do not wash or Dry clothing impregnated with flammable liquids (petrochemical).



Prohibited! Do not allow children to play in or around equipment.

	DANGER Indicates an imminently hazardous situation, which if not avoided, <u>will result</u> in death or serious injury.
	WARNING Indicates a potentially hazardous situation, which if not avoided <u>could result</u> in death or serious injury.
	CAUTION Indicates a potentially hazardous situation which, if not avoided, <u>may result</u> in minor or moderate injury. It may also be used to alert against unsafe practices. Minor burns, pinch points that result in bruises and minor chemical irritation.
	NOTICE Indicates information or a company policy that relates directly or indirectly to the safety of personnel or protection of property.
	This is the user caution symbol. It indicates a condition where damage to the equipment resulting in injury to the operator could occur if operational procedures are not followed. TO REDUCE THE RISK OF DAMAGE OR INJURY, refer to accompanying documents; follow all steps or procedures as instructed.
	This is the electrical hazard symbol. It indicates that there are DANGEROUS HIGH VOLTAGES PRESENT inside the enclosure of this product. TO REDUCE THE RISK OF FIRE OR ELECTRIC SHOCK, do not attempt to open the enclosure or gain access to areas where you are not instructed to do so. REFER SERVICING TO QUALIFIED SERVICE PERSONNEL ONLY
	Caution! To reduce the risk of fire or explosion, do not operate this equipment in any hazardous classified (ATEX) environment.



WARNING

	<ul style="list-style-type: none"> • All Dryers must be installed in accordance to all applicable electrical, plumbing and all other local codes. • These installation and operation instructions are for use by qualified personnel only. To avoid injury and electrical shock, do not perform any servicing other than that contained in the installation and operation instructions, unless qualified.
	Do not install Equipment in an explosive atmosphere.
	<ul style="list-style-type: none"> • Care must be stressed with all foundation work to ensure a stable unit installation, eliminating possibilities of excessive vibration. • Foundation must be level within 13 mm to ensure proper washer operation.
	Do not operate washer or Dryer if door glass is damaged in any way.
	Do not wash or Dry clothing impregnated with flammable liquids (petrochemical).



WARNING





	Children should be supervised to ensure they do not operate or play in or around equipment.
	Keep all panels in place to protect against electrical shock and injury and add rigidity to washer.

This appliance is not intended for use by persons (including children) with reduced physical, sensory or mental capabilities, or lack of experience and knowledge, unless they have been given supervision or instruction concerning use of the appliance by a person responsible for their safety.

A washer should not be allowed to operate if any of the following occur:

- Excessive high water level.
- Machine is not connected to a properly earthed circuit.
- Door does not remain securely locked during the entire cycle.
- Vibration or shaking from an inadequate mounting or foundation.

	Warning! Do not operate equipment if door glass is damaged in any way.
	Warning! Keep clear of rotating parts.
	Prohibited! Do not enter this equipment or space.
	Prohibited! Do not step or stand on this equipment.
	Prohibited! Do not operate without all guards and covers in place.
	Prohibited! Do not operate without all guards and covers in place.
	Prohibited! Do not wash or Dry clothing impregnated with flammable liquids (petrochemical).
	Prohibited! Do not allow children to play in or around equipment.

	Prohibited! Do not attempt to open, touch, or proceed before referring to the manual or unless qualified.
	Mandatory! Read all supporting documentation before operating or maintaining equipment.
	Mandatory! Disconnect power before servicing equipment.
	Mandatory! Lock out and tag out before servicing this equipment.
	Mandatory! Children should be supervised to ensure they do not operate equipment.

Section 1:

Specifications

SPECIFICATIONS

50 lb. Commercial Stack Dryer: T-50x2 Reversing Tumbler DC50X2NC-11EC2R (60 Hz), DC50X2NC-39AB2R (50 Hz)

Cabinet Height (Assumes minimum leveling leg adjustment)	79 1/4"	2012 mm.
Cabinet Width	34 1/2"	876 mm.
Overall Depth	56 3/4"	1441 mm.
Floor to Bottom of Door- Bottom Dryer	7"	178 mm.
Floor to Bottom of Door- Top Dryer	46"	1168 mm.
Door Opening	25 5/8"	651 mm.
Dry Wt. Capacity	50 x 2 lbs.	22.7 x 2 kg.
Cylinder Diameter	32 1/2"	826 mm.
Cylinder Depth	33"	838 mm.
Cylinder Volume	15.84 cu. ft.	448 liters
Lint Screen Area	544 sq. in.	3510 sq. cm.
Gas Input (per dryer- 60 hz)	108,000 Btu/hr	31.7 kW
Gas Input (per dryer- 50 hz)	96,500 Btu/hr	28.3 kW
Gas Supply Connection	1/2"	12.7 mm.
Natural Gas Supply (Water Column)	5-8"	127 mm. - 203 mm.
Natural Burner Manifold (60 hz Water Column)	3.5"	88.9 mm
(50 hz Water Column)	3.5"	88.9 mm
L.P. Supply (Water Column)	11.5 -14"	292 mm. - 356 mm.
L.P. Burner Manifold Pressure (60 hz Water Column)	11"	279 mm
(50 hz Water Column)	10"	254 mm
Exhaust Size	8"	203 mm.
Make-up Air	1.5 sq. ft.	1394 sq. cm.
	Example: 1.5 sq. ft = 1 ft. long X 1.5 ft. wide	
Motor Size	3/4 H.P.	.560 kW
Airflow (60 Hz)	650 CFM	18.4 m ³ /min
Airflow (50 hz)	510 CFM	14.4 m ³ /min

Electrical Specifications – 208-240/60/1

Voltage/Hz/Phase	208-240VAC/60Hz/1Phase
Running Amps	15
Circuit Protection Amps	20
Wire Size	12 gauge
Electrical Service	2 wire + ground

Electrical Specifications – 230/50/1

Voltage/Hz/Phase	230VAC/50Hz/1Phase
Running Amps	15
Circuit Protection Amps	20
Wire Size	3.5 mm ²
Electrical Service	2 wire + ground

Shipping Weight	917 lbs.	416 kg.
Net Weight	857 lbs.	389 kg.
Clearance Behind Machines (min.)	18"	457 mm.

T-50X2 DRYER DIMENSIONS- FRONT VIEW

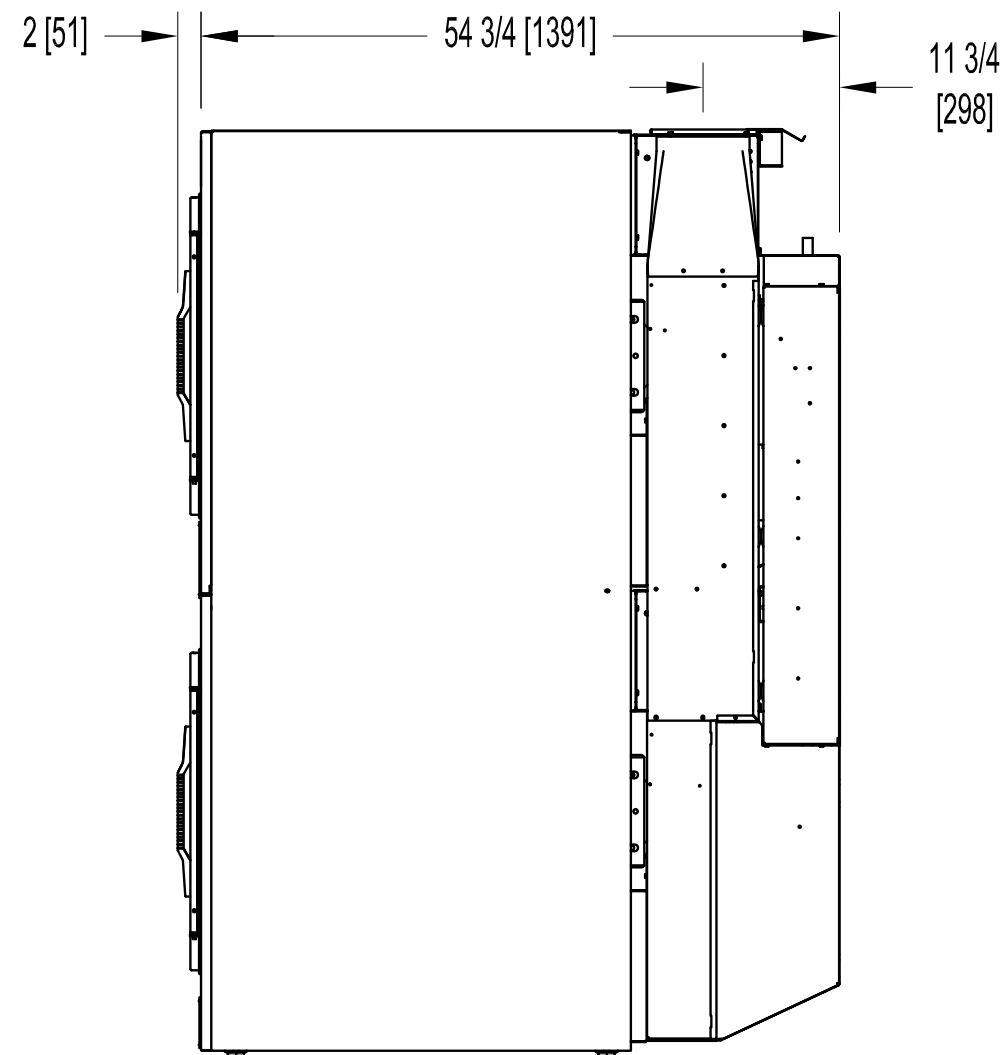
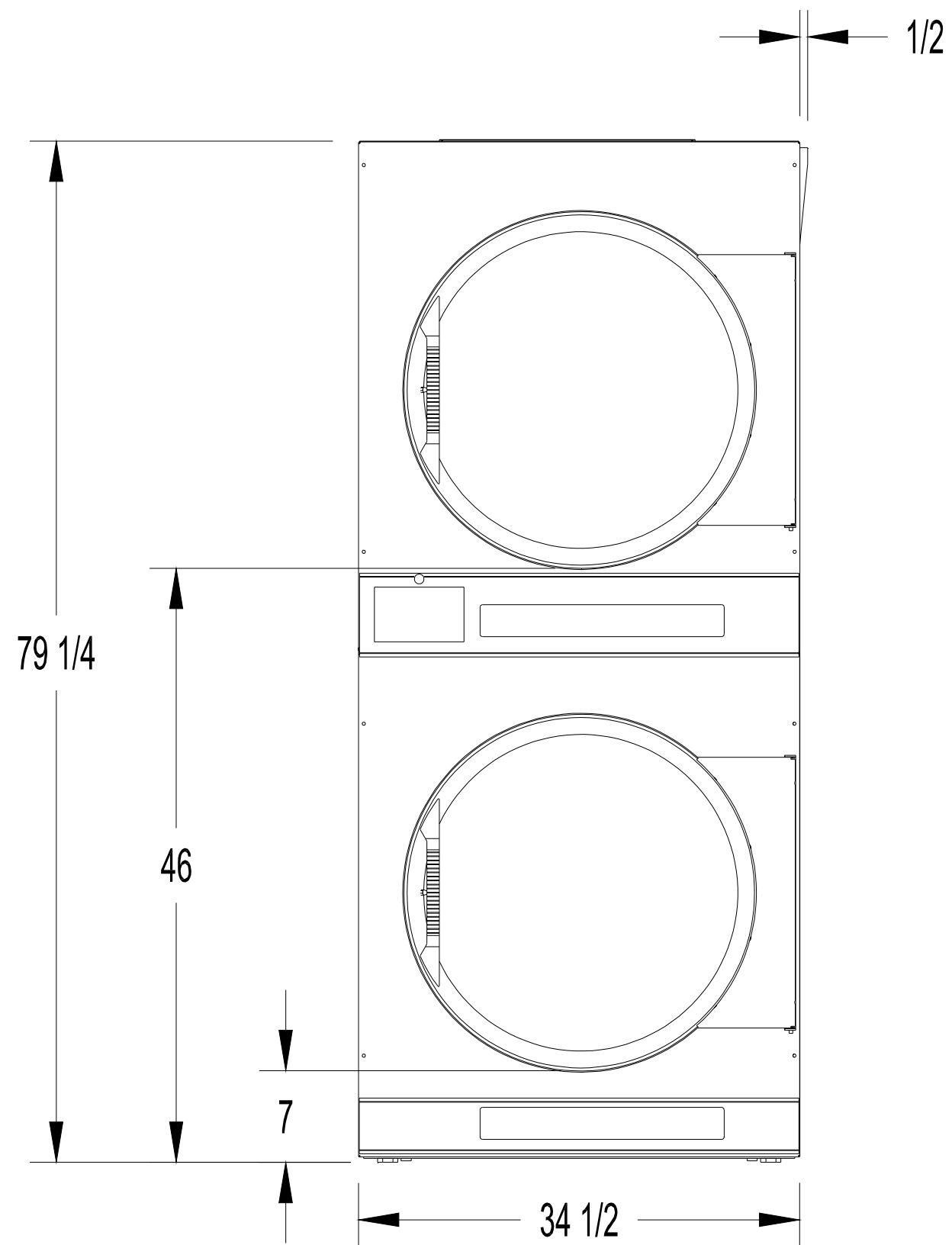

DIMENSIONS ARE IN INCHES [MILLIMETERS]

SIDE

1. Section 2: Installation & Operation

DRYER INSTALLATION

1. CODE CONFORMITY: All commercial dryer installations must conform with local codes, or in the absence of local codes, with the latest edition of the National Fuel Gas Code ANSI Z223.1. Canadian installations must comply with the current Standard CAN/CGA-B149 (.1 or .2) Installation Code for Gas Burning Appliances or Equipment, and local codes if applicable. Australian installations must meet installation requirements and pipe sizing requirements of AS/NZA 5601. The appliance, when installed, must be electrically grounded in accordance with the latest edition of the National Electric Code, ANSI/NFPA70, or, when installed in Canada, with Standard CSA C22.1 Canadian Electrical Code Part 1.

2. INSTALLATION CLEARANCES: This unit may be installed at the following alcove clearances:

- I. Left Side 0"
- II. Right Side 0"
- III. Back 18" (457 mm) (Certified for 6" (150 mm) clearance; however, 18" (457 mm) clearance is necessary behind the motors to allow servicing and maintenance.)
- IV. Front 48" (1220 mm) (to allow use of dryer).
- V. Top Refer to figure labeled "Vertical Clearance Dimensions".
AB. Certification allows 0" clearance at the top 4" (100 mm) back from the front.
However, a 1/4" (6 mm) clearance should be allowed in case the dryer needs moving.
C. A 10" (250 mm) clearance is required from top at all other points.
- VI. Floor This unit may be installed upon a combustible floor.

Do not obstruct the flow of combustion and ventilation air.

Maintain minimum of 1" (25 mm) clearance between duct and combustible material.

Refer to the label attached to the Belt Guard on the rear of the dryer for other installation information and start-up instructions.

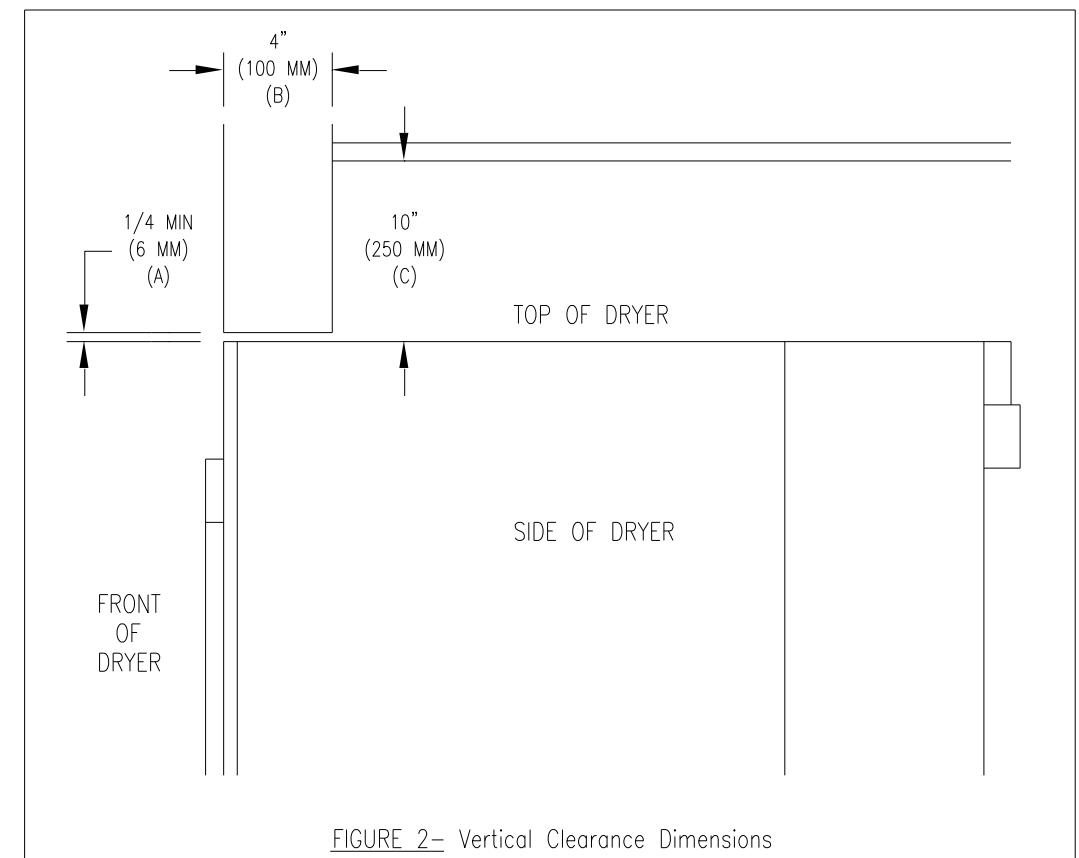

3. MAKE-UP AIR: Adequate make-up air must be supplied to replace air exhausted by dryers on all types of installations. Refer to specifications for the minimum amount of make-up air opening to outside for each dryer. This is a net requirement of effective area. Screens, grills or louvers, which will restrict the flow of air, must be considered. Consult the supplier to determine the free area equivalent for the grill being used. The source of make-up air should be located sufficiently away from the dryers to allow an even airflow to the air intakes of all dryers. Multiple openings should be provided.

The sources of all make-up air and room ventilation air movement to all dryers must be located away from any dry cleaners. This is necessary so that solvent vapors will not be drawn into the dryer inlet ducts. Dry cleaner solvent vapors will decompose in contact with open flame such as the gas flame present in clothes dryers. The decomposition products are highly corrosive and will cause damage to the dryer(s) ducts and clothes loads.

4. ELECTRICAL REQUIREMENTS. The electrical power requirements necessary to operate the unit satisfactorily are listed on the serial plate located on the back panel of each dryer and in the specifications section of this manual. The electrical connection should be made to the terminal board, on the rear of the unit. It is absolutely necessary that the dryer be grounded to a known ground. Individual circuit breakers for each stacked dryer are required. Dryer -11 models are shipped 208VAC, may need adjusted if running 240VAC.

5. GAS REQUIREMENTS.

The complete gas requirements necessary to operate the dryer satisfactorily are listed on the serial plate located on the back panel of the dryer and in the specifications section of this manual. The inlet gas connection to the unit is 1/2-inch pipe thread. However, the size of the piping to supply the dryer should be determined by reference to the National Fuel Gas Code ANSI Z223.1A and consultation with the local gas supplier. An individual gas shutoff valve is recommended for each dryer and may be required by local code (not supplied). A joint compound resistant to the action of liquefied petroleum gases should be employed in making pipe connections. A 1/8-inch NPT plugged tapping, accessible for test gage connection, must be installed immediately upstream of the gas supply connection to the dryer. A drip tee is provided in the unit gas piping to catch dirt and other foreign articles.

All pipe connections should be checked for leakage with soap solution. Never check with an open flame. For altitudes above 2,000 feet (610m), it is necessary to derate the BTU input. Contact your local distributor for instructions. L.P. gas conversion kits are available for this dryer. Contact your local distributor.

CAUTION: The dryer must be disconnected from the gas supply piping system during any pressure testing of that system. Do not expose the dryer's gas control valve to testing pressure.

Burner Set-Up

All gas burner manifolds should be checked for proper gas pressure while burning. Stack dryer burners should be set at 3.5 W.C. while burner operating.

6. EXHAUST INSTALLATION. (Refer to Figure 3) Exhausting of the dryer(s) should be planned and constructed so that no air restrictions occur. Any restriction due to pipe size or type of installation can cause slow drying time, excessive heat, and lint in the room. From an operational standpoint, incorrect or inadequate exhausting can cause a cycling of the high limit thermostat, which shuts off the main burners and results in inefficient drying.

The exhaust duct connection near the top of the dryer will accept an 8" (200 mm) round duct. Individual exhausting of the dryers is recommended. All heat, moisture, and lint should be exhausted outside by attaching a pipe of the proper diameter to the dryer adapter collars and extending it out through an outside wall. This pipe must be very smooth on the inside, as rough surfaces tend to collect lint, which will eventually clog the duct and prevent the dryer from exhausting properly. All elbows must be smooth on the inside. All joints must be made so the exhaust end of one pipe is inside the next one downstream. The addition of an exhaust pipe tends to reduce the amount of air the blower can exhaust. This does not affect the dryer operation if held within practical limits. For the most efficient operation, it is recommended that no more than 14 ft. (4.25 m) of straight 8 in. diameter pipe with two right angle elbows be used for each cylinder.

Maintain a minimum of 1" (25mm) clearance between duct and combustible material.

If the exhaust pipe passes through a wall, a metal sleeve of slightly larger diameter should be set in the wall and the exhaust pipe passed through this sleeve. This practice is required by some local codes and is recommended in all cases to protect the wall.

This type of installation should have a means provided to prevent rain and high winds from entering the exhaust when the dryer is not in use. A hood with a hinged damper can be used for this purpose. Another method would be to point the outlet end of the pipe downward to prevent entrance of wind and rain. In either case, the outlet should be kept clear, by at least 24 in. (610 mm) of any objects, which would cause air restriction.

Never install a protective screen over the exhaust outlet.

When exhausting a dryer straight up through a roof, the overall length of the duct has the same limits as exhausting through a wall. A rain cap must be placed on top of the exhaust and must be of such a type as to be free from clogging. The type using a cone shaped "roof" over the pipe is suitable for this application.

Exhausting the dryer into a chimney or under a building is not permitted. In either case there is a danger of lint buildup, which can be highly combustible.

Installation of several dryers, where a main discharge duct is necessary, will need the following considerations for installation (see Figure 3). Individual 8" (200 mm) exhaust ducts from each dryer should enter main discharge duct at a 45-degree angle in the direction of discharge airflow.

NOTE: Never install the individual ducts at a right angle into the main discharge duct. The individual ducts from the dryers can enter at the sides or bottom of the main discharge duct. Figure 3 indicates the various round main duct diameters to use with the individual dryer ducts. The main duct can be rectangular or round, provided adequate airflow is maintained. The total exhausting (main discharge duct plus duct outlet from the dryer) should not exceed the equivalent of 14 ft. (4.25 m) and two elbows. The diameter of the main discharge duct at the last dryer must be maintained to exhaust end.

NOTE: STATIC BACK PRESSURE should be a maximum of 0.3 in. w.c (7.6 mm w.c) at the rear exhaust outlet of the dryer. If multiple dryers are connected to the common duct, ensure the back draft damper is installed properly.

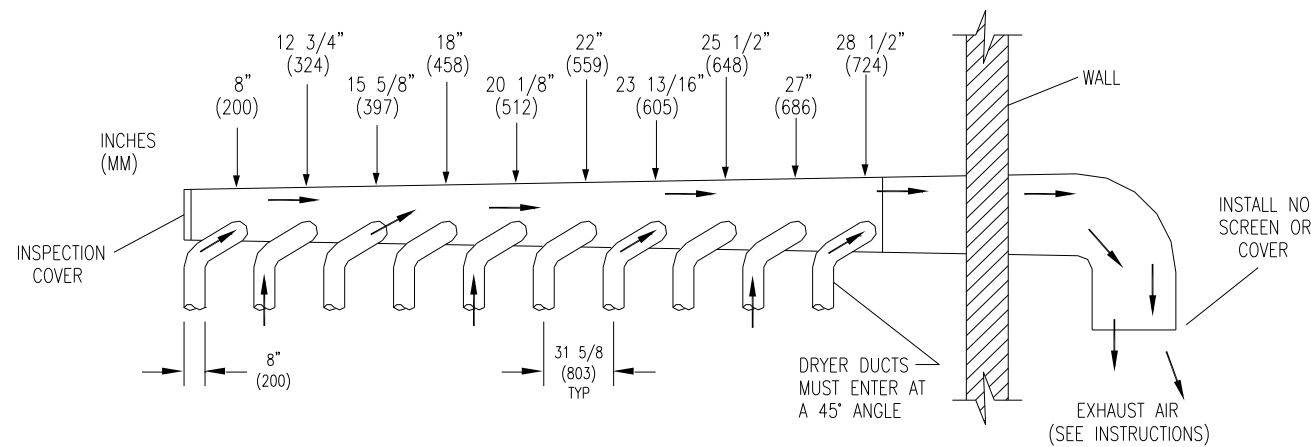

NOTE: A small diameter duct will restrict airflow; a large diameter duct will reduce air velocity - both contributing to lint build up. An inspection door should be provided for periodic clean out of the main duct.

7. DRYER IGNITION (SOLID STATE IGNITION): The solid-state ignition system lights the main burner gas by spark. The gas is ignited and burns only when the gas-relay (in the electronic controller) calls for heat. The procedure for first-time starting of a dryer is as follows.

- I. First review and comply with the "Warnings About Use and Operation" found on the inside front cover of this manual. Be sure electrical power is connected correctly. The dryer must be properly grounded.
- II. Make sure all gas supply lines are purged of air. Close the main gas shut-off valve and wait for five minutes before turning it back on.
- III. Turn on the main electrical power switch. The dryer may be started by following the "Operating Instructions" found later in this manual.
- IV. Natural gas and LPG fired dryers operate in the same manner. When the gas valve relay contacts are closed (indicating a demand for heat), the solid-state ignition control will automatically supply energy to the redundant gas valve. Sparking will continue until a flame is detected by the sensing probe, but not longer than ten seconds. If the gas fails to ignite in 10 seconds, the gas valve closes and the gas system pauses to allow gas to purge from the inside of the dryer. After the pause, the ignition control repeats the ignition trial cycle twice more. If the gas system fails to detect ignition after the three attempts, the system will "lock out". No further attempts will be performed automatically. To reset the ignition control electrical power to the ignition control must be interrupted. This can be done by opening the dryer door (stopping the dryer) for 15 seconds. Closing the door and pushing the "Start" button will repeat the ignition trial cycle.

8. MAIN BURNER ADJUSTMENT. The primary air shutter of each main burner must be properly adjusted for the correct air-gas ratio. Loosen the shutter locking screw. Adjust the shutter by closing it sufficiently to give a blue flame with a yellow tip. Next open the shutter until the yellow tips are at a minimum. After adjustment securely lock each shutter in position by tightening the shutter locking screws.

9. DRYER SHUTDOWN. To render the dryer inoperative, turn off the main gas shut off valve and disconnect the electrical supply to the dryer.

TRANSIENT VOLTAGE SURGE SUPPRESSORS

Like most electrical equipment your new machine can be damaged or have its life shortened by voltage surges due to lightning strikes which are not covered by factory warranty. Local power distribution problems also can be detrimental to the life of electrical components. We recommend the installation of transient voltage surge suppressors for your new equipment. These devices may be placed at the power supply panel for the complete installation and don't require an individual device for each machine.

These surge protectors help to protect equipment from large spikes and also from small ongoing spikes in the power that occur on a day to day basis. These smaller surges can shorten overall life of electrical components of all types and cause their failure at a later date. Although they can't protect against all events, these protective devices have a good reputation for significantly lengthening the useful life of electronic components.

Electronic Components are helped to have a longer useful life when they are supplied with the clean stable electrical power they like.

We are including the following names and links to a few suppliers of these devices for those who don't currently have a source.

MANUFACTURER	LINK
MCG Surge Protection	mcgsurge.com
Eaton Corporation	eaton.com/us/en-us
Schneider Electric	se.com/us/en
Asco Power Technologies	ascopower.com/us/en
Emerson Electric Co.	emerson.com/en-us

Touch Pad Description







Indicator Lights (LED's)

Description

- Cycle (1 through 5)** These L.E.D.s are on solid when a particular cycle is chosen for operation or programming.
- Gas Valve** This L.E.D. is part of the 4-digit numeric display and will be on solid during the drying part of a cycle when the gas valve does not need to be on. The L.E.D. will be blinking when the gas valve needs to be on. The L.E.D. will not be on solid or blinking (off) if the cycle is stopped, complete, in cool down, or terminated.
- Programming** These L.E.D.s are on solid as they are selected during the programming of the dryer controller.
- Stop** This L.E.D. is on solid when either the stop button is pressed once or the door is opened during an operating cycle.

Switches (push buttons)

Description

-  **Up/Increase** This touch pad switch will increment (increase) dry time, cool down time, and drying temperature. It will also scroll upwards when selecting a dry cycle.
-  **Down/Decrease** This touch pad switch will decrement (decrease) dry time, cool down time and drying temperature. It will also scroll downwards when selecting a dry cycle.
-  **Program** This touch pad switch allows the dryer controller to enter the permanent programming mode.
-  **Select/Enter** This touch pad switch will select one of the three variable parts of the dry cycle (dry time, temperature, or cool down) by sequencing through them. Once one of the variable parts of the dry cycle is chosen and changed, this touch pad switch will enter the new (changed) value into the dry cycle program.
-  **Cycle** This touch pad switch allows the dryer controller to enter the temporary programming mode.
-  **Stop** This touch pad switch will stop the dryer during a dry cycle without clearing the present drying cycle if pressed once. If pressed and released twice, consecutively, the present dry cycle will be cleared.



Start

This touch pad switch will start the operation of a dry cycle if pressed and released once. Pressing and holding this touch pad switch will display the current temperature of the dryer heat sensor as long as it is held in the depressed position.

Message

Description

- LOAD** This message is displayed after a dry cycle is complete and the dryer loading door has been opened or the STOP touch pad key on the dryer controller has been pressed and released twice.
- donE** This message blinks immediately after completion of the dry cycle and continues to blink until the stop key on the dryer controller touch pad is pressed or the dryer loading door is opened.
- Prog** This message is displayed when entering the permanent programming mode.
- .15** This message appears while the dryer is in the heating time of a dry cycle. The decimal point will blink if the output for the gas valve is on, or remain on constantly if the output for the gas valve is not on. The number represents the total time left in the dry cycle (includes cool down time).
- C02** This message appears when the cool down time of the dry cycle is reached. The letter "C" represents the cool down (non-heating) part of the dry cycle. The number(s) after the letter "C" represent(s) the total time remaining in the dry cycle.
- F5** This message appears if there is a dryer fault. The letter "F" indicates a fault and the number after the "F" represents the specific fault that has occurred. There are five different faults that can appear (F1 through F5).

OPERATING INSTRUCTIONS

To dry a load of items, you must choose one of the five-programmed dry cycles. Each of these five dry cycles may be modified in two different ways to match your load. Please, refer to the "Permanent Reversing Dryer Controller Programming" or "Temporary Reversing Dryer Controller Programming" section of this manual.

There are two parts to each dry cycle. The first part is the heating time, which is when the gas valve is cycled on and off according to the temperature setting in the dry cycle program. The second part is the cool down time, which is after the heating part of the dry cycle, and when the cylinder continues to turn, but no heat is applied.

There will always be at least two minutes of cool down time for each dry cycle. The maximum amount of cool down time is 60 minutes if the controller has a red dot sticker or 15 minutes if the controller has no red dot sticker.

During a reversing dry cycle, the tumbler will rotate in one direction for one minute, decelerate for four seconds, and then rotate in the opposite direction for one minute. This motion will repeat for the duration of the dry cycle. If the controller has a red dot sticker, the amount of reversing time can be set to either one or two minutes. To change the reversing time, the 4-digit numerical display must show "LOAD". Then, press and hold the SELECT/ENTER touch pad switch and then press the UP touch pad switch to set the time to two minutes or the DOWN touch pad switch to set the time to one minute. The buzzer will then beep to indicate the change was successful. The change will be retained even if the power is removed. The factory default is one minute.

The five default dry cycle values are shown in the "REVERSING DRYER CONTROLLER FACTORY DEFAULT PROGRAM SETTINGS" table in this manual.

To improve the drying capabilities of this dryer, you should always separate (untangle) the individual articles in your load before using the dryer.

In the following instruction steps, things that are displayed on the 4-digit numerical display will be in "quotation marks" and any touch pad switches on the dryer controller that physically need to be pressed will be in **CAPITAL AND BOLD LETTERS**.

- 1) Place your untangled load into the dryer cylinder and close the dryer loading door. Notice that the dryer controller 4-digit numerical display should show the word "**LOAD**". If it does not show this word, then press and release the **STOP** touch pad switch on the dryer controller twice.
- 2) Press and release the **UP** or **DOWN** touch pad switch on the dryer controller to select a dry cycle.
- 3) Once the desired dry cycle is selected, press and release the **START** touch pad switch.

After the dryer controller **START** touch pad switch is pressed, the dryer cylinder will start rotating and the two-digit total dry cycle time, along with a decimal point, will appear on the dryer controller display.

The time shown on the dryer controller display will count down to the programmed cool down time. At that time, the display will change from the decimal point and two-digit number to a letter "C" and two digits.

The letter "C" represents the cool down portion of the dry cycle. The two digits represent the amount of time remaining in the dry cycle. The two-digit time, shown on the dryer controller display, will count down to zero.

When the time decrements to zero, the dryer controller display will flash the work "done" and the end of cycle tone will sound.

At that point, the wrinkle free cycle will automatically begin. This cycle will wait two minutes, if the door is not opened or the **STOP** touch pad switch on the dryer controller is not pressed, and then rotate the cylinder for 10 seconds and stop. This two-minute of idle time and 10 seconds of tumble time will repeat a total of 10 times, at which time the wrinkle free cycle stops. The cylinder will not rotate again until a new dry cycle is started.

During the dry cycle, either pressing the **STOP** touch pad switch on the dryer controller or opening the dryer loading door will stop the dry cycle and not clear it. If you press the **STOP** touch pad switch on the controller and then open the dryer loading door, the dry cycle will not be cleared. However, if you open (or open and close) the dryer loading door and then press the **STOP** touch pad switch on the dryer controller, the present dry cycle will be cleared and the word "LOAD" will appear on the dryer controller display.

Jumper Options

There are two jumpers and one push button on the component side of the dryer controller printed circuit board.

The jumper located at the lower right side of the circuit board controls whether the controller display shows and operates in the Fahrenheit or Celsius mode. This jumper is labeled as TEMP SELECT and has three pins.

The bottom and middle pins are for Celsius and the top and middle pins are for Fahrenheit, which is indicated by the letter C for Celsius and the letter F for Fahrenheit.

The other jumper, located at the upper right side of the component side of the dryer controller circuit board, is used for choosing either a reversing or non-reversing type of dryer. This jumper is labeled as REV and NON-REV. This jumper must be in the reversing position, which are the bottom and middle pins. If the jumper is in the non-reversing position, the heating part of the dry cycle will not operate properly. The dryer will not reverse direction.

Factory Reset

The push button, which is located at the lower middle side of the component side of the dryer controller circuit board, is used to reset all five of the dry cycles to the factory default settings. It is labeled as DEFAULT SETTINGS. Even the dry cycles that have been modified using the permanent programming procedure will be changed back to the factory default settings when using this push button. This push button must be pressed and held for at least three seconds with power applied to the dryer controller circuit board.

DRY CYCLE	DRYER DIRECTION	COOL DOWN TIME (minutes)	TOTAL CYCLE TIME (minutes)	DRYING TEMPERATURE		DRYER LOAD
				F	C	
1	REV.	5	35	180	82	Towels, pads, heavy cotton
2	REV.	2	20	170	77	Sheets, blended materials
3	REV.	5	25	180	82	Cotton
4	NON-REV.	2	20	130	54	Synthetic Materials
5	NON-REV.	2	25	175	79	Blended Materials

TEMPORARY REVERSING DRYER CONTROLLER PROGRAMMING

Temporary programming mode will allow the change of the stored dry cycle settings in the dryer controller for one complete dry cycle. After the dry cycle is complete, the default settings that existed before the temporary change are restored. The temporary dry cycle can be stopped and cleared at any time during the dry cycle operation.

To temporarily change a dryer controller cycle, follow the procedures below. Things that are displayed on the 4-digit numeric display will be in "quotation marks". Touch pad switches on the dryer controller that physically need to be pressed will be in **CAPITAL AND BOLD LETTERS**.

If, at any time, you want to escape the temporary programming mode while changing the program settings, you can press the **STOP** touch pad switch on the dryer controller if the 4-digit numeric display is not flashing. The **SELECT/ENTER** touch pad switch on the dryer controller can be pressed and released to enter the flashing value shown on the 4-digit numeric display and allow you to escape.

If you press and release the **STOP** touch pad switch on the dryer controller, when the 4-digit numeric display is not flashing, the temporary changes to the dry cycle program will be cancelled. The stored dry cycle settings that existed before the temporary change will then be restored.

If, at any time, you want to start the temporary dry cycle during the temporary programming mode, press and release the **START** touch pad switch on the dryer controller if the 4-digit numeric display is not flashing. The **SELECT/ENTER** touch pad switch on the dryer controller can be pressed and released to enter the flashing value shown on the 4-digit numeric display and allow you to start the temporary dry cycle. If you start the temporary dry cycle, the 4-digit numerical display will change the total dry time and count down to 0 as the dry cycle progresses.

PROCEDURE

- 1) Make sure the dryer is not in a dry cycle. The 4-digit numeric display on the dryer controller will show "LOAD" when the dryer is not in a dry cycle.
- 2) Press and release the **UP** or **DOWN** touch pad switch on the dryer controller to choose the dry cycle that you want to change (dry cycle 1 through 5). The dry cycle L.E.D. will illuminate to indicate which dry cycle you are choosing. If you press and hold down either the **UP** or **DOWN** touch pad switch, the controller will sequence through the five dry cycles.
- 3) Press and release the **CYCLE** touch pad switch on the dryer controller once you have chosen the dry cycle you want to change. After you press the **CYCLE** touch pad switch, the programming L.E.D. and the dry time L.E.D. will illuminate, the dry cycle L.E.D. will remain illuminated, and the total dry time will be displayed on the 4-digit numeric display.
- 4) Press and release the **UP** or **DOWN** touch pad switch on the dryer controller to change the total cycle time. Once either the **UP** or **DOWN** touch pad switch is pressed, the dry time L.E.D. and the total dry time on the 4-digit numeric display will flash. If you press and hold down either the **UP** or **DOWN** touch pad switch, you will increment (**UP** arrow) or decrement (**DOWN** arrow) through the total dry times available (1 through 60 minutes). This display dry time includes the cool down time along with the heated time. To not change the cool down time, do not press either the **UP** or **DOWN** touch pad switch. Go to the next step.

- 5) Press and release the **SELECT/ENTER** touch pad switch on the dryer controller. Once the **SELECT/ENTER** touch pad switch is pressed and released, the dry time L.E.D. will switch off, the dry cycle L.E.D. and programming L.E.D. will remain on, the temperature L.E.D. will illuminate, and the drying temperature will be shown on the 4-digit numeric display.
- 6) Press and release either the **UP** or **DOWN** touch pad switch on the dryer controller to change the drying temperature. Each press and release of either the **UP** or **DOWN** touch pad switch will either increase or decrease, respectively, the temperature by five degrees Fahrenheit or three degrees Celsius, depending on how your dryer controller is set up. Once either the **UP** or **DOWN** touch pad switch is pressed, the temperature L.E.D. and the drying temperature on the 4-digit numeric display will flash. If you press and hold down either the **UP** or **DOWN** touch pad switch, you will increment (**UP** arrow) or decrement (**DOWN** arrow) your way through the available drying temperatures (105° Fahrenheit or 41° Celsius, up to 195° Fahrenheit or 90° Celsius). If you do not want to change the drying temperature, do not press either the **UP** or **DOWN** touch pad switch. Go to the next step.
- 7) Press and release the **SELECT/ENTER** touch pad switch on the dryer controller. Once the **SELECT/ENTER** touch pad switch is pressed and released, the temperature L.E.D. will switch off, the dry cycle L.E.D. and programming L.E.D. will remain on, the cool down L.E.D. will illuminate, and the cool down time will be shown on the 4-digit numeric display.
- 8) Press and release either the **UP** or **DOWN** touch pad switch on the dryer controller to change the cool down time. Once either the **UP** or **DOWN** touch pad switch is pressed, the temperature L.E.D. and the cool down time on the 4-digit numeric display will flash. If you press and hold down either the **UP** or **DOWN** touch pad switch, you will increment (**UP** arrow) or decrement (**DOWN** arrow) through the cool down times available (2 through 60 minutes if the controller has a red dot sticker or 2 through 15 minutes if the controller has no red dot sticker). To not change the cool down time, do not press either the **UP** or **DOWN** touch pad switch. Go to the next step.
- 9) Press and release the **SELECT/ENTER** touch pad switch on the dryer controller. Once the **SELECT/ENTER** touch pad switch is pressed and released, the cool down L.E.D. will switch off, the dry cycle L.E.D. and the programming L.E.D. will remain on, the reversing L.E.D. will illuminate, and either "rEv" (reversing mode) or "nrEv" (non-reversing mode) will be shown on the 4-digit numeric display.
- 10) Press and release either the **UP** or **DOWN** touch pad switch to change between reversing and non-reversing operation. Once either the **UP** or **DOWN** touch pad switch is pressed, the reversing L.E.D. and the "rEv" (reversing mode) or the "nrEv" (non-reversing mode) shown on the 4-digit numeric display will flash. To not change the reversing or non-reversing mode of operation, do not press either the **UP** or **DOWN** touch pad switch. Go to the next step.
- 11) Press and release the **SELECT/ENTER** touch pad switch on the dryer controller. Once the **SELECT/ENTER** touch pad switch is pressed and released, the programming L.E.D. will switch off, the reversing L.E.D. and the dry cycle L.E.D. will remain on, and the flashing reversing (rEv) or the non-reversing (nrEv) on the 4-digit numeric display will stop flashing and remain.
- 10) At this point, you have two choices:
 - a) You can perform the modified dry cycle by pressing and releasing the **START** touch pad switch on the dryer controller touch pad. If you start the modified cycle, the total dry time will appear on the 4-digit numeric display and it will count down to 0 as the dry cycle progresses.
 - b) You can clear the modified dry cycle program by pressing and releasing the **STOP** touch pad switch. If you choose to clear the modified dry cycle, the 4-digit numeric display will change to "LOAD".

TEMPORARY REVERSING DRYER CONTROLLER PROGRAMMING EXAMPLE

REQUIREMENTS: Dry a load with 40 minutes of actual heat at 185°F and five minutes of cool down.

The following procedure will show you how to temporarily modify the existing dry cycle 5 program for one cycle of drying. It is based on the assumption that the factory defaults have not been permanently changed. If they have been changed, the steps of this procedure will be the same, but the values that are displayed will be different. The amount of times that the **UP** or **DOWN** touch pad switches of the dryer controller must be pressed and released may also be different.

If you want the change to be permanent, go to the "PERMANENT DRYER CONTROLLER PROGRAMMING" section of this manual.

PROCEDURE:

- 1) After the load has been placed in the dryer, press and release the **UP** or **DOWN** touch pad switch on the dryer controller until the L.E.D. for dry cycle 5 is illuminated.
- 2) Press and release the **CYCLE** touch pad switch on the dryer controller. You will see the number "25" on the dryer controller display. The programming L.E.D. and dry time L.E.D. will be illuminated.
- 3) Press and release the **UP** touch pad switch on the dryer controller 17 times so that the display will show a flashing "42". When the **UP** touch pad switch is pressed the first time, the number "26" will be flashing on the dryer controller display. Each number after that will also flash.
- 4) Now, press and release the **SELECT/ENTER** touch pad switch on the dryer controller. The number "42" will stop flashing, the dry time L.E.D. will switch off, the dryer controller display will now show "175", the temperature L.E.D. will illuminate, and the programming L.E.D. and dry cycle 5 L.E.D. will remain on.
- 5) Press and release the **UP** touch pad switch on the dryer controller one time so the controller display will show a flashing "185". Each press of the **UP** touch pad switch will increment the temperature by five degrees.
- 6) Now, press and release the **SELECT/ENTER** touch pad switch on the dryer controller. The number "185" will stop flashing, the temperature L.E.D. will switch off, the dryer controller display will now show a number "2", the cool down L.E.D. will illuminate, and the programming L.E.D. and dry cycle 5 L.E.D. will remain on.
- 7) Press and release the **SELECT/ENTER** touch pad switch on the dryer controller, since the desired cool down time is two minutes. After you press the **SELECT/ENTER** touch pad switch, the cool down L.E.D. will switch off, the dryer controller display will show "nrEv", the reversing L.E.D. will illuminate, and the programming L.E.D. and the cycle 5 L.E.D. will remain on.
- 8) Press and release either the **UP** or **DOWN** touch pad switch on the dryer controller once. A flashing "rEv" will appear on the dryer controller display and the reversing L.E.D. will start to flash. Each press and release of either the **UP** or **DOWN** touch pad switch will toggle between the reversing mode ("rEv") and the non-reversing mode ("nrEv").
- 9) Press and release the **SELECT/ENTER** touch pad switch on the dryer controller. Once the **SELECT/ENTER** touch pad switch is pressed and released, the programming L.E.D. and the reversing L.E.D. will switch off, the dry cycle 5 L.E.D. will remain on, and the flashing "rEv" will stop flashing and remain on.
You are now ready to start the new dry cycle. The new dry cycle will be in effect for one dry cycle only. After the dry cycle is done, or if the **STOP** touch pad switch on the dryer controller is pressed and released twice, consecutively, the cycle 5 program will revert to the factory default settings.
If you press the **START** touch pad switch on the dryer controller, the controller display will change from the "ReV" to the number "42" and dry cycle 5 will begin.

PERMANENT REVERSING DRYER CONTROLLER PROGRAMMING

The permanent programming mode will allow the change of the stored dry cycle settings in the dryer controller until the operator physically changes them again. The factory default settings can be restored in the dryer controller by pressing the default settings push-button on the back (component) side of the dryer controller circuit board. It is labeled and located at the lower middle side of the printed circuit board, as you face the component side of the board. It must be pressed and held down for at least three seconds.

To permanently change a dryer controller cycle, follow the procedure below. Things that are displayed on the 4-digit numeric display will be in "quotation marks". Touch pad switches on the dryer controller that physically need to be pressed will be in **CAPITAL AND BOLD LETTERS**.

If, at any time, you want to escape the permanent programming mode while changing the settings, you can press the **STOP** touch pad switch on the dryer controller if the 4-digit numeric display is not flashing. The **SELECT/ENTER** touch pad switch on the dryer controller can be pressed and released to enter the flashing value shown on the 4-digit numeric display and allow you to escape.

PROCEDURE

- 1) Make sure the dryer is not in a dry cycle. The 4-digit numeric display on the dryer controller will show "LOAD" when the dryer is not in a dry cycle.
- 2) Press and release the **PROG** touch pad switch on the dryer controller.
- 3) Press and release the **UP** touch pad switch on the dryer controller. The programming L.E.D. will illuminate and the 4-digit numeric display on the dryer controller will change to "Prog".
- 4) Press and release either the **UP** or **DOWN** touch pad switch to choose the dry cycle you want to change (dry cycle 1 through 5). The dry cycle L.E.D. will illuminate to indicate which dry cycle you are choosing. If you press and hold down either the **UP** or **DOWN** touch pad switch, the controller will sequence through the five dry cycles.
- 5) Press and release the **SELECT/ENTER** touch pad switch once you have chosen the dry cycle you want to change. After you press the **SELECT/ENTER** touch pad switch, the dry time L.E.D. will illuminate, the dry cycle L.E.D. and the programming L.E.D. will remain illuminated, and the total dry time will also be displayed on the 4-digit numeric display.
- 6) Press and release either the **UP** or **DOWN** touch pad switch on the dryer controller to change the total dry time. Once either **UP** or **DOWN** touch pad switch is pressed, the dry time L.E.D. and the total dry time on the 4-digit numeric display will flash. If you press and hold down either the **UP** or **DOWN** touch pad switch, you will increment (**UP** arrow) or decrement (**DOWN** arrow) through the total dry times available (1 through 60 minutes). The dry time on the controller display includes the cool down time along with the heated time. To not change the total dry time, do not press either the **UP** or **DOWN** touch pad switch. Go to the next step.
- 7) Press and release the **SELECT/ENTER** touch pad switch of the dryer controller. Once the **SELECT/ENTER** touch pad switch is pressed and released, the dry time L.E.D. will switch off, the dry cycle L.E.D. and programming L.E.D. will remain on, the temperature L.E.D. will illuminate, and the drying temperature will be shown on the 4-digit numeric display.

- 8) Press and release either the **UP** or **DOWN** touch pad switch of the dryer controller to change the drying temperature. Each press and release of either the **UP** or **DOWN** touch pad switch will either increase or decrease, respectively, the temperature by five degrees Fahrenheit or three degrees Celsius, depending on how your dryer controller is set up. Once either the **UP** or **DOWN** touch pad switch is pressed, the temperature L.E.D. and the drying temperature on the 4-digit numeric display will flash. If you press and hold down either the UP or DOWN touch pad switch, you will increment (**UP** arrow) or decrement (**DOWN** arrow) your way through the available drying temperatures (105° Fahrenheit or 41° Celsius, up to 195° Fahrenheit or 90° Celsius). If you do not want to change the drying temperature, do not press either the **UP** or **DOWN** touch pad switch. Go to the next step.
- 9) Press and release the **SELECT/ENTER** touch pad switch on the dryer controller. Once the **SELECT/ENTER** touch pad switch is pressed and released, the temperature L.E.D. will switch off, the dry cycle L.E.D. and programming L.E.D. will remain on, the cool down L.E.D. will illuminate, and the cool down time will be shown on the 4-digit numeric display.
- 10) Press and release either the **UP** or **DOWN** touch pad switch on the dryer controller to change the cool down time. Once either the **UP** or **DOWN** touch pad switch is pressed, the cool down L.E.D. and the cool down time on the 4-digit numeric display will flash. If you press and hold down either the **UP** or **DOWN** touch pad switch, you will increment (**UP** arrow) or decrement (**DOWN** arrow) through the cool down times available (2 through 60 minutes if the controller has a red dot sticker or 2 through 15 minutes if the controller has no red dot sticker). To not change the cool down time, do not press either the **UP** or **DOWN** touch pad switch. Go to the next step.
- 11) Press and release the **SELECT/ENTER** touch pad switch on the dryer controller. Once the **SELECT/ENTER** touch pad switch is pressed and released, the cool down L.E.D. will switch off, the dry cycle L.E.D. and programming L.E.D. will remain on, the reversing L.E.D. will illuminate, and either "rEv" (reversing mode) or "nrEv" (non-reversing mode) will be shown on the 4-digit numeric display.
- 12) Press and release either the **UP** or **DOWN** touch pad switch on the dryer controller to change between reversing and non-reversing operation. Once either of the **UP** or **DOWN** touch pad switch is pressed, the reversing L.E.D. and the "rEv" (reversing mode) or the "nrEv" (non-reversing mode) shown on the 4-digit numeric display will flash. To not change the reversing or non-reversing mode of operation, do not press either the **UP** or **DOWN** touch pad switch. Go to the next step.
- 13) Press and release the **SELECT/ENTER** touch pad switch on the dryer controller. Once the **SELECT/ENTER** touch pad switch is pressed and released, the cool down L.E.D. will switch off, the dry cycle L.E.D. and programming L.E.D. will remain on, and the 4-digit numeric display will change to "Prog".
- 12) Press and release the STOP touch pad switch on the dryer controller to save the cycle program and escape the programming mode. If you want to change the same dry cycle program again, press the **SELECT/ENTER** touch pad switch and continue at step 6 of this procedure. If you want to modify another dry cycle program, go to step 4 of this procedure and continue.
- 13) If you pressed the **STOP** touch pad switch to escape the programming mode, you may now start the dry cycle by pressing the **START** touch pad switch.

PERMANENT REVERSING DRYER CONTROLLER PROGRAMMING EXAMPLE

REQUIREMENTS: Dry a load with 50 minutes of actual heat at 195°F and three minutes of cool down.

The following procedure will show you how to permanently modify the existing dry cycle 5 program for one cycle of drying. It is based on the assumption that the factory defaults have not been permanently change. If they have been changed, the steps of this procedure will be the same, but the values that are displayed will be different. The amount of times that either the **UP** or **DOWN** touch pad switch of the dryer controller must be pressed and released may also be different.

If you want the change to be temporary (for only one dry cycle), go to the "TEMPORARY REVERSING DRYER CONTROLLER PROGRAMMING" section of this manual.

PROCEDURE:

- 1) After the load has been placed in the dryer, press and release either the **UP** or **DOWN** touch pad switch on the dryer controller until the L.E.D. for dry cycle 5 is illuminated.
- 2) Press and release the **PROG** touch pad switch on the dryer controller. The display of the dryer controller will not change.
- 3) Immediately, press and release the **UP** touch pad switch on the dryer controller. The controller display will change from "L0Ad" to "Prog". You have now entered the permanent programming mode. The dry time L.E.D. will remain on and the programming L.E.D. will illuminate.
- 4) Press and release the **SELECT/ENTER** touch pad switch once. The dry time 5 L.E.D. and programming L.E.D. will remain on, the dry time L.E.D. will illuminate, and the dryer controller will show the number "25".
- 5) Press the **UP** touch pad switch 28 times until the display of the dryer controller shows the number "53".
- 6) Press and release the **SELECT/ENTER** touch pad switch of the dryer controller once. The dry cycle 5 L.E.D. and programming L.E.D. will remain on, the dry time L.E.D. will switch off, the temperature L.E.D. will illuminate, and the dryer controller display will show the number "175".
- 7) Press and release the **UP** touch pad switch four times until the dryer controller display shows the number "195".
- 8) Press and release the **SELECT/ENTER** touch pad switch of the dryer controller. The dry cycle 5 L.E.D. and the programming L.E.D. will remain on, the temperature L.E.D. will switch off, the cool down L.E.D. will illuminate, and the dryer controller display will show the number "5".
- 9) Press and release the **UP** touch pad switch once until the dryer controller display shows the number "3".
- 10) Press and release the **SELECT/ENTER** touch pad switch of the dryer controller. The dry cycle 5 L.E.D. and the programming L.E.D. will remain on, the cool down L.E.D. will switch off, the reversing L.E.D. will illuminate, and the dryer controller display will show "nrEv".
- 11) Press and release either the UP or DOWN touch pad switch on the dryer controller once. A flashing "rEv" will appear on the dryer controller display and the reversing L.E.D. will start to flash. Each press and release of either the UP or DOWN touch pad switch will toggle between the reversing mode ("rEv") and the non-reversing mode ("nrEv").

Section 3:

Service Procedures

Service Procedures

Clothes Door Removal

1. The clothes door may be removed from the hinge bracket by unscrewing and removing the allen-head pivot screw located at the door upper hinge point.
2. Next lean the door out of the top of the hinge bracket and lift the door from the bottom hinge pin.

NOTE: the spacer between the bottom of the door and the hinge.

Clothes Door Latch Adjustment

1. Loosen the lock nut on the latching stud. It is located directly behind the door handle.
2. Open the loading door.
3. Screw the door catch stud in or out as necessary and then retighten the lock nut.

Door Switch Removal And Installation

1. Each door switch is located directly behind the hinge plate of the loading door assembly.
2. The entire switch can now be pulled from the front panel opening.
3. The switch has two clips that hold it in place on the rear of the switch.
4. With the panel removed, you can now squeeze the two clips and allow switch to be pushed back through panel and grasped from the front and switch removed.

Installation Of Clothes Door Window And Gasket

1. Place the clothes door, with its face down, on a solid surface.

NOTE: Prewarming the gasket makes the installation much easier.

2. Install the window gasket on the clothes door flange. The wider lip of the gasket should be on the bottom side or front face of the clothes door and the ridges should be up.
3. Locate the seam at the latching stud.
4. Apply a soapy water solution or rubber lubricant to the gasket.
5. Slide the glass into the middle of the door ring and gasket with half of the glass above the door and half below.
6. While pressing down on the glass, stand the door up and use a modified screw driver with the end rounded off to install half of the glass. Lay the door down and install the other half.
7. At the six o'clock position, pry the glass up enough to install the black spacer. (Reuse from old door gasket)

High Limit Thermostat Locations And Functions

- A. Burner Housing-** This hi-limit is located on the back side of each burner housing.
1. The thermostat opens the circuit to the main burners in the event of malfunction in the gas control area or temperature control. This thermostat will open quickly if there is a significant loss of air flow over the burner area.
 2. It is covered by a guard and is held in place by two screws. There are spacers between the thermostat and bracket which must be used to give proper operation.

B. Manual Reset Over Temperature Safety Thermostats- The second hi-limit thermostat is located on the right side of each burner housing as you view from the back of the machine. It is just above the gas valve and covered by a guard with a small access hole.

1. The manually resettable thermostat limits the operating temperature a dryer can reach should some abnormal situation occur.
2. Should one of the thermostats be tripped, that particular tumbler will cease to heat until the thermostat is reset. Once the dryer cools, the thermostat may be reset by inserting a pencil or stick through the opening in the thermostat cover.

REMOVAL: To remove either the hi-limit thermostat on the rear of the burner housing or the over-temperature thermostat on the right side of the burner housing, remove the power to the machine and mounting screws holding its respective guard. Next, remove the terminal of each wires attached to the thermostat. Lastly, remove the mounting screws holding the thermostat to the burner.

Pressure Regulator Adjustment

Use the following procedure whenever it is necessary to check the pressure regulator setting.

NOTE: Any adjustment of the pressure regulator must be made with a manometer attached at the plug in the main burner manifold.

1. Shut off the gas supply to the dryer.
2. Remove the 1/8" pipe plug from the end of the main burner manifold.
3. Attach a manometer to the manifold end.
4. Remove the pressure regulator cover screw on the gas valve.
5. Open the shutoff valve, and operate the dryer.
6. Adjust the pressure for a manometer reading of 3.5" water column gas pressure. (11.0" for L.P.)

NOTE: The main burners must be operating when adjusting the pressure regulator.

7. Shut off the gas supply to the dryer. Remove the manometer and install the 1/8" pipe plug in the manifold.
8. Open the shut off valve, start the dryer and check for gas leaks while the burners are ignited.

Heat Sensor

This unit takes the place of the regulating thermostat on a mechanical timer dryer. The Heat Sensor is a thermistor. The way these work is fairly simple. As the temperature goes up, the resistance in the thermistor (heat sensor) goes down. As the temperature drops, the resistance in the thermistor (heat sensor) goes up.

Electronic Control Removal

Unlock the retaining lock in the control assembly. Slide the control out of the machine holding the control by the metal tray. There is enough wire length to allow removing the control tray from the machine before disconnecting the wires.

Membrane Switch Replacement

The control buttons are an adhesive membrane switch assembly which may be replaced separately. Slide the control out to gain access to disconnect the ribbon connector. The ribbon connector must be pushed solidly and squarely into its connector when connecting a new membrane switch.

Temperature Sensor Testing

If either tumbler display shows an F1 or F2, that is an indication of possible temperature sensor problems for that tumbler. Before replacing a sensor, check the wires and connections of the sensor for damage. The sensor lead wires are very small and care should be used in routing and connecting them. The sensors are located under the tumblers and may be viewed by removing the lint screen. The temperature sensor should have 10,000 ohms resistance at room temperature if okay.

Temperature Testing

To check the temperature in the dryer tumbler, press and hold the upper or lower start button for the tumbler being checked and while holding the start button also press the temperature button for the temperature to be checked. The display will read out the current temperature.

50Lb Stack Temperature Sensor Removal

UPPER - First remove the Electronic Control. Once the Control is removed, disconnect the Temp Sensor wires by removing the two gray wire nuts. Remove the two temp sensor mounting screws, 5/16 head, remove Temp the Sensor bracket assy. Remove the sensor from bracket and replace and reinstall in reverse operation.

LOWER -To remove the Lower Temp Sensor and Bracket it is necessary to remove the Lower front panel; note you will have to loosen the upper panel to remove the lower panel, and disconnect the door switch wires. Next disconnect the Temp Sensor wires by removing the two gray wire nuts. Remove the two temp sensor mounting screws, 5/16 head, remove Temp Sensor bracket assy. Remove the sensor from the bracket and replace and reinstall in reverse operation.

50Lb Stack Upper Front Panel Removal

The loading door does not have to be removed to remove the front panels on this model.

1. Remove the left two screws with finish washers.
2. Remove the right two screws with finish washers, at this time the front panel is loose but connected by the harness to the door switch.

Lower Front Panel Removal

To remove the lower front panel a procedure similar to the upper may be used. However, the bottom of the upper panel must be loosened and pulled out to allow the upper flange of the lower panel clearance to be removed.

NOTE: Always remove power from the machine before changing drive belts or working with the drive system.

Final Drive Belt Replacement

To replace the final drive belt turn the cylinder slowly by hand and work the belt off of the large pulley.

Motor Drive Belt Replacement

To replace the motor drive belt the final drive belt should be removed as above. Cut the old motor belt and remove. The new motor drive belt fits inside of three of the four motor mounting bolts. To achieve this, remove these three bolts one at a time and slide the belt in past each in turn. In this way the motor is always supported by 3 bolts at any time.

NOTE: All drive belts are self adjusting.

Tumbler Pulley Removal And Installation

Remove bolt and washers holding pulley to cylinder shaft. Reinsert bolt then using two or three jaw puller Pull pulley straight off of shaft.

Inverter Drive Motor removal

Remove power from the machine by turning off the circuit breaker.

Remove Rear Control box cover by removing the one 5/16 screw.

Remove rear belt guards.

Disconnect Motor wires, T1, T2, and T3 from the inverter drive, and the ground screw from the control box.



MOTOR WIRES T1, T2, T3,

Remove the Tumbler pulley belt to release tension on the motor tension chain and motor.

Remove the motor tension spring and chain.

Loosen the three Motor rod collar set screws (5/32 Allen).

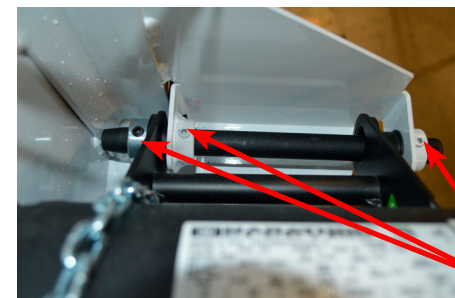

5/32 ALLEN

Remove the Motor rod and the Motor.

Reassemble in reverse order.

Motor Blower Assembly Removal And Installation

1. Remove Belts.
2. Disconnect the Motor harness connector.
3. Remove the Tumbler pulley. Remove the 3/4" bolt, Next remove the pulley using "T" bar puller (needed two 3/8"-16 UNC bolts).
4. Remove the Blower back plate (Motor attached). Remove the 1 5/16" harness clamp bolt, then remove nine 3/8" nuts and then tilt the blower fan to remove.
5. The blower fan is held in place with 2 square headed set screws. Upon reassembly, one blower set screw should fit in the counter sink and the other should mount on the flat side of the shaft. Use red

loctite on the set screws and torque to 165 in/lbs.

6. The Motor is mounted with 4 bolts to the motor mounting bracket on the rear of the dryer.
7. Reassemble in reverse order.

Air Flow Switch Operation And Adjustment

The air flow switch assembly is part of the ignition safety circuit and insures that the burners don't operate unless there is air flow. When the drive motor and blower are running the flat actuator is pulled in against the back of the dryer closing the switch. If this doesn't happen ignition will not occur. The air flow switch assembly is mounted by two screws through the bracket. It can be adjusted by loosening these mounting screws and moving the switch forward or backward.

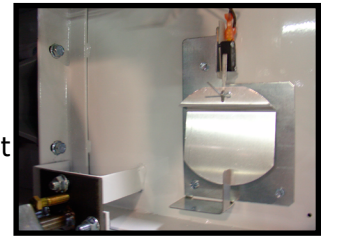

Ignition Transformer Fuse

The 1.5 amp fuse protects the ignition transformer. To remove it just twist and pull it out.

Electronic Ignition Module

This machine uses an electronic spark ignition system to directly light the burners in each tumbler.

1. The electronic ignition module for each tumbler is located inside the electrical box. This is the metal box on the back right of the Dryer.
2. The red wire from the transformer traveling thru the 1.5 amp fuse and into the module supplies the 24VAC required to operate the entire direct ignition system.
3. The black colored hi-voltage wire (spark plug type) plugs onto the post connector on the module, and the multi-wire plug fits into the side of the module.

Spark Ignition Module Removal

If the ignition modules are mounted on a bracket, see section A. Otherwise, see section B.

A: With mounting bracket

Remove the connector housing of the wiring harness attached to the ignition module. Then, remove the terminal of the hi-voltage cable attached to the ignition module. Next, remove the mounting screws holding the ignition module mounting bracket in the rear control box. Lastly, remove the nuts holding the ignition module on its mounting bracket.

B: Without mounting bracket

Remove all of the terminals of the wiring harness attached to the ignition module. Then, remove the terminal of the hi-voltage cable attached to the ignition module. Lastly, remove the mounting screws holding the ignition module in the control box. If there is no spark or intermittent spark, check black hi-voltage lead wire for damage

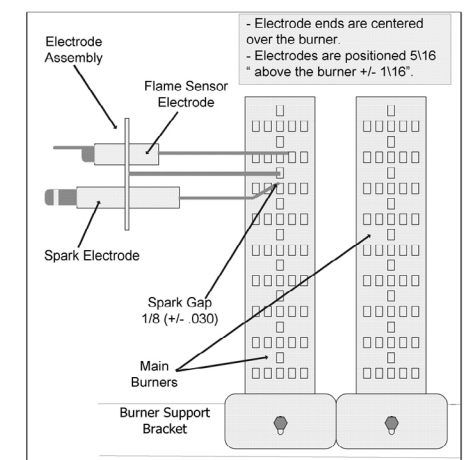

NOTE: Proper grounding of the ignition system

(yellow wires) is very critical for proper ignition sequence.

Ignition System-Function & Sequence

During normal dryer operation, the following occurs:

1. The dryer electronic control calls for heat.
2. If the drive motor is running, the motor safety circuit provides power to the electronic control. If the control senses that the heat should be on, a circuit is closed allowing power through the high limit thermostat and air flow switch to the ignition transformer. The transformer provides 24VAC to the ignition module and sparking occurs at the ignition electrode. At the same time 24VAC is applied to the gas valve.
3. Once the flame is established, the sensing electrode detects the presence of flame and the sparking stops.
4. If for any reason the flame is not established in a period of 10 seconds, the electronic control will try this sequence for 3 tries. Normally the 10 seconds "Trial For Ignition" period is ample to establish and prove flame.
5. If the flame is shutdown or blown out during operation, the ignitor will immediately go into "Trial For Ignition" again for 10 seconds.
6. However, at the end of 3 separate retries of 10 seconds "Trial for Ignition", the flame is not established, the ignition system goes into "Safety Lock-Out" and will not reactivate the "Trial for Ignition" until there is a current interruption for a period of 15 seconds. This interruption can be provided by opening the dryer loading door and allowing the machine to come to a complete stop for 15 seconds.

Ignition System-Checkout

1. If flame is present during "Trial For Ignition" period but the system shuts down, there may be an improper ground. The entire ignition system is grounded together including the electrode assembly, the electrode mounting bracket, the burners and the burner bracket. Shutdown can also occur if for some reason the system isn't sensing the flame. Check the sensor for damage and check the connections of the sensor lead.
2. If there is no spark or intermittent spark, check black hi-voltage lead wire for damage or cracks in insulation. (This lead wire must not be taped or connected to any metal edges along its length to prevent pinching and arcing. Also, do not bundle this wire with other wires.)

NOTE: Spark gap and electrode location are important. If the electrode is damaged or mounting is changed the spark gap may not be correct for ignition to occur. Check for cracks in the ceramic insulator. Replace electrode assembly if necessary. Also check for carbon or foreign material on the electrodes and clean if necessary.

Spark Electrode Assembly-Removal

1. Remove the electrode cover and disconnect wires to the electrodes.
2. Remove two screws to detach electrode assembly.

Gas Valve Removal (shut off manual gas valve to stop gas flow before removing gas control valve)

1. Disconnect union at gas valve and disconnect wires from gas valve operator coils.
2. Remove right manifold mounting bracket screws and slide manifold to remove from left bracket.

Main Burner Orifice Removal

1. Remove manifold and gas valve assembly as above.
2. Using an open end wrench, remove orifices from manifold.

Main Burner Removal

1. Remove the 4 screws securing the cover for the burner housing and the one screw mounting the high limit cover. With the burner housing cover removed, there is complete access to the burner assemblies.

Recirculation Chamber Inspection

1. Remove Resettable manual overtemp sensor and remove inspection plate in burner chamber between main burners and rear back panel of dryer.

Cylinder Removal

1. Remove the front panel in front of the cylinder.
2. Remove drive belt and pulley, from cylinder shaft.
3. Pull the cylinder from the front of the machine.

Adjustment Of Cylinder Assembly With Front Panel Removed

1. Loosen the two top adjusting bolts and two bottom adjusting nuts and lock nuts holding the bearing housing to the drive plate.
2. Loosen the four mounting bolts on the side channels.
3. Open the clothes door and insert a 1/4" thick shim at the 3 and 9 o'clock positions and a 1/8" thick shim at the 6 o'clock position.
4. Tighten the two bottom adjusting nuts and tighten locking nuts.
5. Tighten the bottom right mounting bolt, then the top left mounting bolt. Tighten the remaining two bolts. (Shim where and if necessary.)
6. Tighten the two top adjusting bolts.
7. Remove all the shims from between the front panel flange and cylinder (3, 6, and 9 o'clock).
8. Spin the cylinder to check for rubbing baffles, pressing down hard while rotating. If rubbing is detected, repeat procedure paying particular attention to placement of shims between bearing housing and side channels.

Tumbler Through Bolt Access Cover

Remove 4 screws that mount the air flow switch to the back of the dryer. Remove 2 screws that retain access cover. With access cover removed, tightness on the tumbler through bolts can be checked and tumbler alignment can be adjusted.

Bearing Housing Removal

After removing cylinder as previously outlined, simply unbolt the bearing housing and remove.

Section 4:

Troubleshooting & Wiring Schematics

REVERSING DRYER FAULT CODES

FAULT #	FAULT DESCRIPTION	ACTION
F1	Short in thermostat sensor circuit	Dryer stops and "F1" flashes on the 4-digit display. When short circuit on sensor input is removed, "LOAd" appears on the 4-digit display and the remaining dry time is reset.
F2	Open thermostat sensor.	Dryer stops and "F2" flashes on the 4-digit display. When a good sensor is connected to sensor input, "LOAd" appears on the 4-digit display and the remaining dry time is reset.
F3	EEPROM corrupted	Dryer will not start and "F3" appears on the 4-digit display. The power to the dryer must be cycled to reset the controller. Fault should only occur when starting a dry cycle.
F4	Gas valve on fault.	The drying temperature did not increase 1°F. in 5 minutes. "F4" will flash on the display and the dry cycle will finish without calling for heat (energizing gas valve). Opening the door or pressing the STOP touch pad switch will reset the fault and clear the remaining time in the dry cycle.
F5	Temperature fault	The drying temperature is at least 25°F. above the temperature setting. "F5" will flash on the 4-digit display and the dry cycle will finish without calling for heat (energizing the gas valve). The power to the dryer must be cycled to reset the controller.

Troubleshooting Tips

Symptom	Probable Cause	Suggested Remedy
Tumbler does not turn	Drive belts	Check both drive belts. Replace if failed.
	Drive motor	Check capacitor and motor. Replace if failed.
	Door switch	Check door switch contacts and adjustment. Adjust or replace the door switch.
	Electronic Control	Is electronic control closing motor relay to power drive motor? Check for motor light on electronic control. If no light change control. If light is on, check voltage and wiring to motor.

Troubleshooting Tips Continued

Symptom	Probable Cause	Suggested Remedy
Tumbler turns but no spark at burner	Glass fuse	Check small glass control fuse in back of dryer. Replace if failed.
	Temperature Sensor	The temperature sensor should have between 30,000 ohms and 60,000 ohms resistance at room temperature if okay. Replace if not in this range.
	Ignition	Check for 24VAC output from transformer.
	Transformer	Replace if have 120VAC between black & white and no 24VAC between red and yellow.
	Over temperature	Check to see if manually resettable thermostat. Thermostat is kicked out. Reset by pushing red reset button.
	Ignition control	Check for 24VAC coming into the control on the at burner red wire. If voltage, then check for 24VAC out on the brown wire. Also check for spark at the ignitor. If no 24VAC output or no spark to the ignitor, replace ignition control.
	Air Flow Switch	Check air flow switch to be sure it closes when dryer is running. If not, adjust or replace switch.
	Hi-limit	Check for continuity. Should be 0 ohms resistance when cold. If not, replace thermostat.
	Gas supply	No gas can cause system lockout.
	Electronic Control	Is electronic control closing gas relay to power Control heat circuit? Check for gas light on electronic control. If no light change control. If light is on, check voltage and components in heat circuit at transformer at rear of unit.

Troubleshooting Tips Continued

Symptom	Probable Cause	Suggested Remedy
Tumbler turns, ignition sparks, no flame	Gas supply	Make sure gas supply is working.
	Gas pressure	Make manometer check of gas pressure. Adjust if necessary.
	Spark Electrode Sensor	Check for damage to electrode or mounting. Replace if necessary.
	Gas valve	Check coil continuity, replace valve if failed.
	Ignition Control	Check for 24VAC to gas valve coils. If no voltage replace ignition control.
Burner Lights, but goes on and off	Electrodes	Check low voltage harness for possible wire break or cuts to allow no signal back to ignition control.
Slow drying	Temperature Setting	Check program for correct high temperature setting. Adjust if necessary.
	Air flow restrictions necessary	<ol style="list-style-type: none"> 1. Check lint screen and clean if necessary. 2. Check exhaust for correct length and clean if necessary. 3. Check exhaust damper to insure that it opens when dryer is running and closes when dryer is not in use. 4. Check makeup air to insure that it is adequate. Increase makeup air if necessary. 5. Check static Back pressure no more than .3
	Temperature Sensor	The temperature sensor should have between 30,000 ohms and 60,000 ohms resistance at room temperature if okay. Replace if not in this range.

Troubleshooting Tips Continued

Symptom	Probable Cause	Suggested Remedy
Erratic display	Initial Start-up	If erratic on initial start-up, leave power on for approximately one hour and check machine operation again.
	Grounding	Machine must be grounded by separate conductor back to neutral bar in breaker box.
	Program	Check program and make corrections if necessary.
	Voltage spike	Power down machine for 20 seconds and repower. If no improvement, replace control.
Manual overtemp Tripping Frequently	Recirculating chamber Lint Accumulation	Remove manual overtemp thermostat and inspect in chamber for excessive lint build up. Access also gained to this chamber by removing recirculation duct mounted at bottom of chamber, or the panel inside burner chamber between burners and rear back panel.
	Exhaust ducting Excessive lint buildup	Remove exhaust duct at rear of dryer and inspect for excessive lint build up in complete duct from dryer to where duct exits building.
	Clean lint off of top heat air chamber above tumbler	Remove front panel completely. Be careful of any wiring attached. Remove heated air chamber cover and clean above tumbler back to burner housing.

Kits, Assemblies, & Common Parts

Description	Part Number
LP to Natural Conversion Kit for White Rodgers	9732-142-004
LP to NG Conversion Kit for 9857-134-001 & -002	9732-142-002
Kit - A to C series Conversion, Black, 120v	9732-307-002
Kit - A to C series Conversion, Blue, 120v	9732-307-001
Kit - 8650-012-004 Lock with spacer	9732-344-002
Controls Assy, Black	9857-187-004
Ignition Control Box	9857-182-001
Thermostat, Hi-Limit	9576-203-002
Thermostat, Overtemp	9576-207-008
Fuseholder	9200-001-002
Fuse 1.5amp	8636-018-001
Motor Run Relay	5192-299-002
Transformer, Ignition	8711-013-001
Lint Screen	9555-057-008
Air Flow Switch	9536-461-009
Door Switch	9539-487-001
Drive Belt	9040-076-003
Spider/Trunnion	9568-017-001
Door Handle	9244-082-001



Section 7:

Parts Data
50# Stack

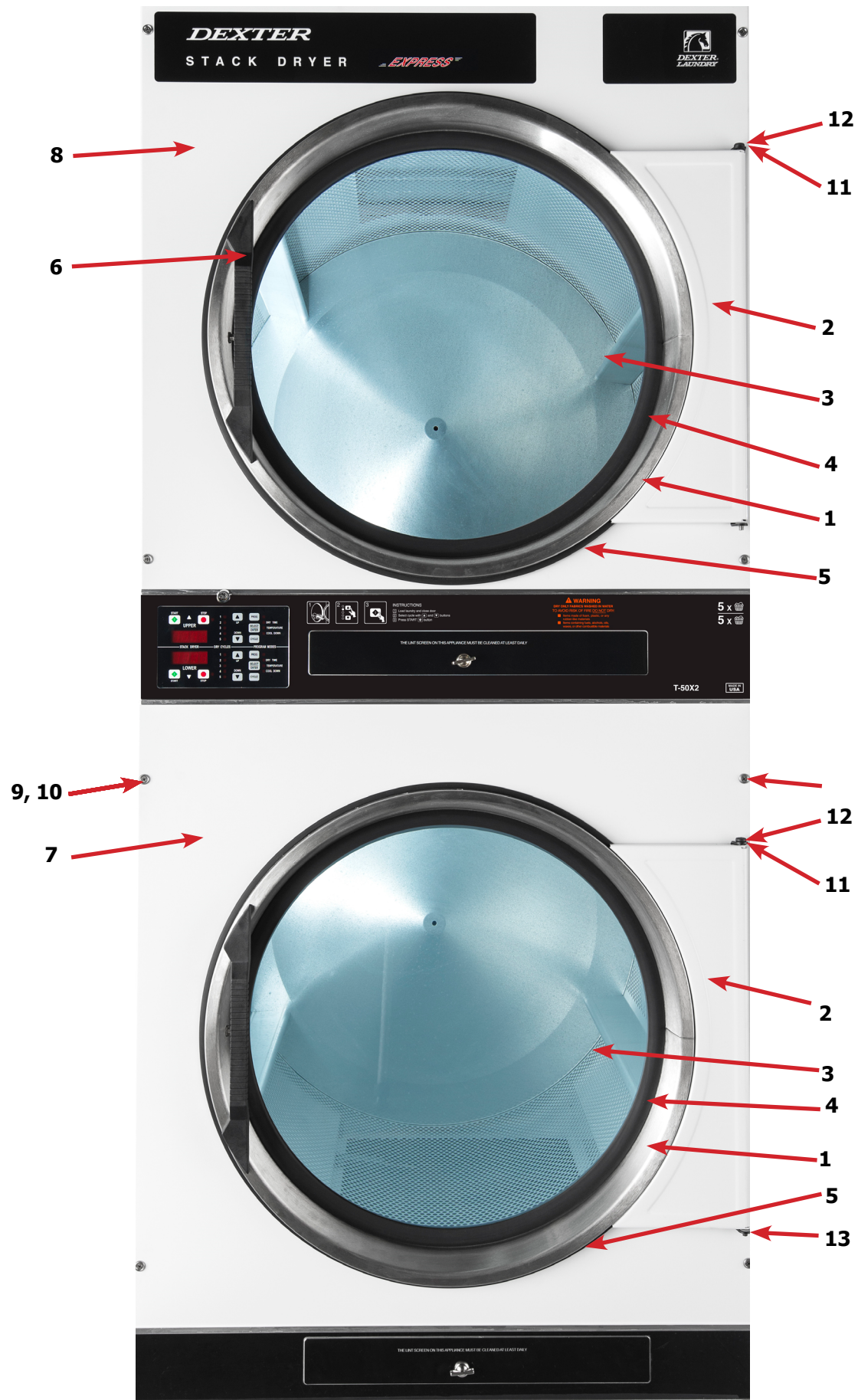

Cabinet Group

Key	Description	T-50X2-11 Reversing	QTY
*	Door Assy., Loading Complete-Wht	9960-285-008	2
*	Door Assy., Loading Complete-SS	9960-285-011	2
1	Door Assy., Loading-SS(ring only)	9960-284-002	2
1	Door Assy., Loading-Chrome(ring only)	9960-284-004	2
1	Door Assy., Loading-Blk(ring only) (after D1.22290.005)	9960-320-004	2
2	Plate Assy., Hinge (Wht)	9982-353-002	2
2	Plate Assy., Hinge (SS)	9982-353-001	2
*	Screw, Hinge to Door	9545-012-015	8
*	Nut, Hinge to Door	8640-413-002	8
*	Cover, Hinge Plate	9074-340-002	2
*	Screw, Phillips-10B x 3/8	9545-008-010	4
3	Glass, Door	9212-002-004	2
4	Gasket, Glass Black	9206-413-002	2
*	Support, Door Glass	9548-117-000	2
*	Tool Install Dryer Door Gasket	8545-064-001	1
5	Gasket, Outer Rim Black	9206-420-005	2
6	Handle, Loading Door	9244-082-001	2
*	Screw, Handle 1/4-20 x 3/8	9545-018-017	4
*	Stud, Door Catch, 7/8	9531-033-003	2
*	Nut, Hex	8640-413-001	2
*	Nut, Acorn	8640-413-003	2
*	Catch, Loading Door	9086-015-002	2
*	Pop Rivet for mtg. catch	8638-190-009	4
*	Lockwasher	8641-582-006	4
*	Spring Nut (Before Serial D1.21180.036)	8640-399-001	6
*	Expansion Nut (After Serial D1.21180.036)	8640-442-001	6
7	Panel Assy., Front- Lower (Wht)	9989-517-011	1
7	Panel Assy., Front- Lower (SS)	9989-517-009	1
8	Panel Assy., Front- Upper (Wht)	9989-517-015	1
8	Panel Assy., Front- Upper (SS)	9989-517-013	1
*	Insulation Front Panel, half moon (top)	9277-054-001	2
*	Insulation Front Panel, half moon (bottom)	9277-054-002	2
9	Screw, FLHDCR, 10B x 1	9545-008-014	14
*	Finish Washer	8641-585-001	6
*	Spring Nut (Before Serial D1.21180.036)	8640-399-001	12
*	Expansion Nut (After Serial D1.21180.036)	8640-442-001	12
11	Strap, Hinge (SS/Black)	9544-069-005	2
*	Screw, Hinge to Panel	9545-012-028	8
12	Screw, Door to Hinge Strap (Special Black Type)	9545-052-001	2
13	Washer, Fiber	8641-436-003	2
*	Switch, Door Closed	9539-487-001	2
*	Cabinet Touch Up Paint (White)	9472-001-013	1

Cabinet Group Continued

Key	Description	T-50X2-11 Reversing	QTY
15	Escutcheon, Upper	9994-050-001	1
16	Trim, Overlay-Upper Black	9435-044-001	1
17	Escutcheon, Lower	9994-051-001	1
18	Trim, Overlay-Lower Black	9435-031-001	1
*	Screw, #4-40 x 3/16	9545-020-009	20
19	Nameplate Stack Dryer Express Black	9412-167-001	1
*	Lint Drawer Assembly Black	9866-005-005	2
20	Overlay Trim, Lint Drwr-Black	9435-032-002	1
*	Felt Seal (back of lint screen assembly)	9532-143-001	2
*	Lint Screen Assembly ONLY (no front)	9805-033-002	2
*	Replaceable Lint Screen Only	9555-057-008	2
21	Lock-Door, Service (thumb turn), Lint Drawer	8650-026-002	2
*	Cam, Lock	9095-044-001	2
*	Strap, Screen (Sides)	9544-092-001	4
*	Strap, Screen (Front)	9544-089-001	2
*	Strap, Screen (Rear)	9544-090-001	2
*	Lint Screen Strap Hold Down Screws 10Bx 1/4	9545-008-001	32
22	Controls Assy, Black	9857-187-004	1
*	Harness, Electronic Control	9627-885-002	1
23	Lock and Key, Control	8650-012-003	1
*	Cam, Lock	9095-041-001	1
*	Key only (6324)	6292-006-007	1
*	Harness, Heat Sensor	9627-886-001	1
*	Wire Nut Connector Grey	8640-276-002	4
24	Sensor Temp Control	9501-004-004	2
*	Bracket for Heat Sensor Mounting (Under Basket) w/ sensor	9501-008-002	2
*	Screw, Round Head (Mounts sensor; phillips head)	9545-045-005	2
*	Grommet, 3/16 ID	9209-037-002	2
*	Leg, Leveling 1/2"	8544-006-001	4
*	Leveling Leg Wrench	8545-061-002	1
*	Cover, Cabinet (Top)	9074-320-001	1
*	Insulation Cabinet Cover	9277-041-017	1
*	LP Kit for 50Lb Stk Dryers	9732-102-013	1
*	Strap - Bead Tie	9544-041-002	1
*	Screws, Mounting-Coin Vault	9545-008-024	2

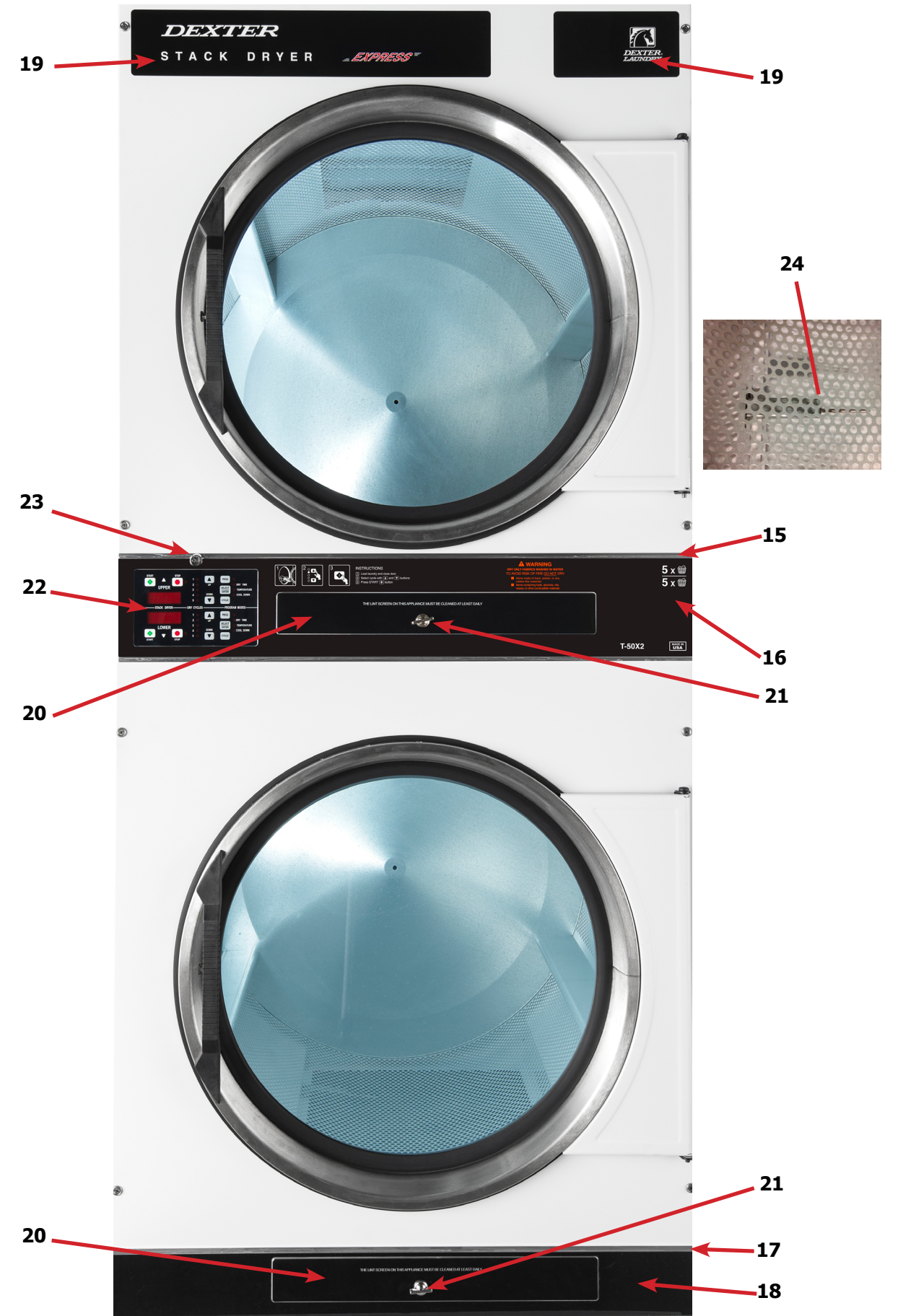

Modular Cabinet Group (After Serial D1.24099.011)

Key	Part Number	Description	Quantity
1	9945-168-001	Cabinet Base Assembly.....	1
*	9989-735-002	Back Panel Assembly.....	2
2	9989-736-003	RH Side Panel Assembly	2
3	9989-736-004	LH Side Panel Assembly.....	2
4	9750-023-001	RH Lint Rail Guide Assembly	2
5	9750-024-001	LH Lint Rail Guide Assembly.....	2
6	9049-133-001	RH Baffle.....	2
7	9049-134-001	LH Baffle	2
*	9489-062-001	Baffle Reinforcement	6
8	9029-371-001	Angled Baffle Bracket	4
9	9870-103-001	Heat Chamber Assembly.....	2
10	9029-374-001	Baffle Support Bracket.....	2
11	9989-737-001	Intermediate Panel Assembly.....	1
12	9636-253-001	Controls Wrapper	1
13	9046-108-001	Top Cabinet Brace.....	1
*	9491-009-001	Rivet-Blind 3/16 Steel	220
*	9491-009-005	Rivet-Blind 3/16 White Painted	52
*	9545-008-024	Screw-10abx3/8	9

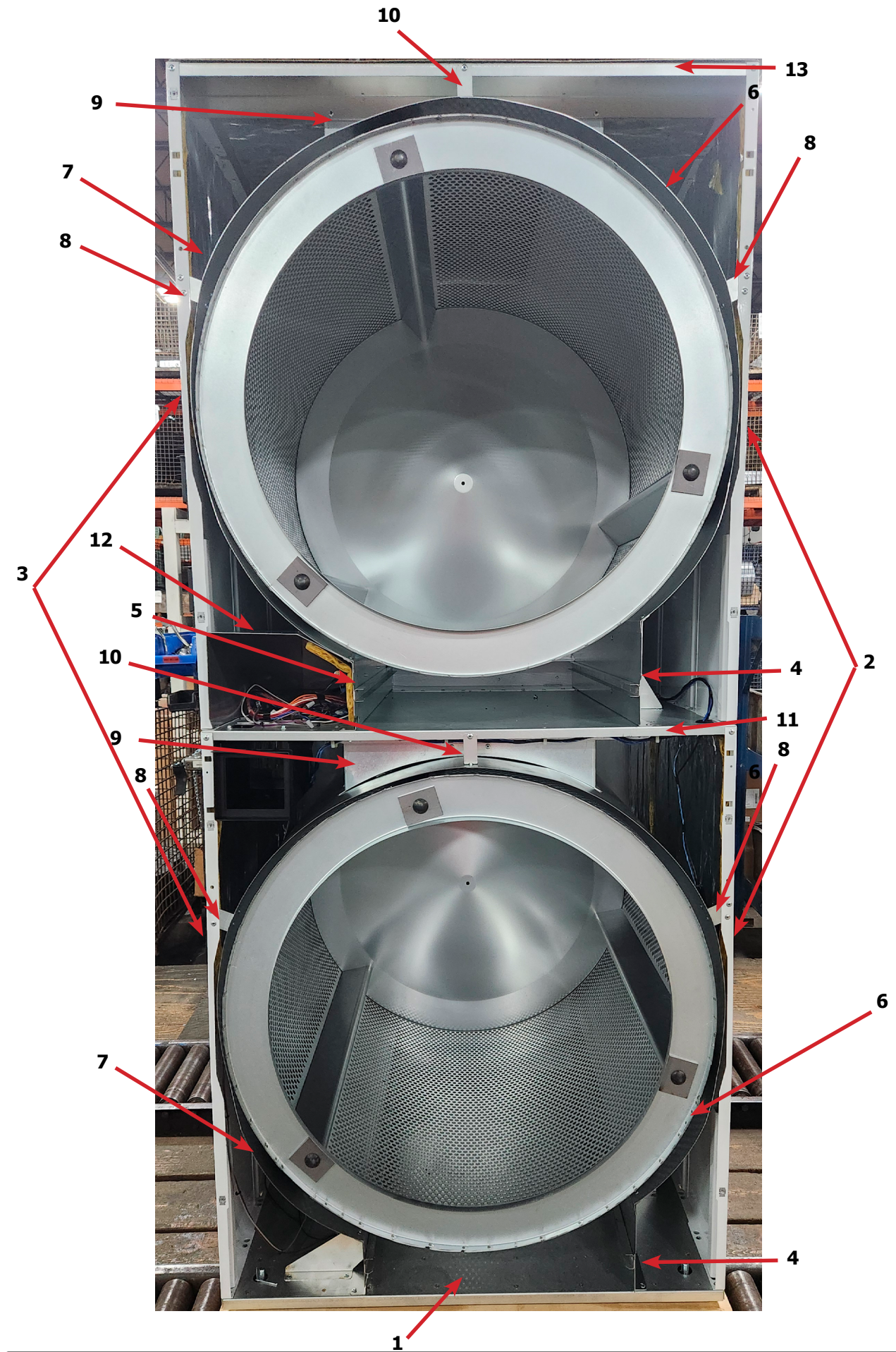

Rear View Photos

Key	Description	T-50X2-11 Reversing	QTY
1	Pulley, Driven	9908-047-002	2
*	Tolerance Ring	9487-234-005	2
2	Washer-Flat, 1/2"	8641-581-026	2
3	Lock Washer, 1/2"	8641-582-016	2
4	Bolt, 1/2"-13 x 1" 1/4"	9545-017-009	2
5	Belt, Drive	9040-076-003	2
6	Air Flow Switch, Assembly	9801-098-001	2
7	Motor-Drive, 2Hp.	9376-319-001	2
8	Pulley-Motor, Drive	9453-169-012	2
*	Screw-Set, 5/16"-18 x 1/2"	9545-028-013	4
9	Rod-Motor Mounting	9497-222-008	2
*	Bushing, Motor Support	9053-074-002	4
10	Collar-Shaft, w/Set Screw	9076-052-002	2
11	Spring, Belt Tension	9534-319-002	2
12	Chain, Spring Tension, 15 1/2" (27 Links)	9099-012-008	2
13	Hook, "S" Hook	9248-022-002	2
14	Drive-VFD, Inverter, 2Hp 230VAC	9375-032-011	2
*	VFD Cooling Fan	9189-013-001	1
*	Assembly, Impeller-Blower Motor (15-17)	9919-019-001	2
15	Plate Assembly, Impeller-Blower Motor	9982-388-002	2
*	Nut, 5/16"-18	8640-400-003	8
*	Impeller, w/Set Screws	9278-043-001	2
16	Motor, Blower	9376-311-005	2
17	Bolt-Motor Mounting, 5/16, 18 x 5/8"	9545-014-004	8
18	Nut-1/4" x 20, Mounting Plate, Impeller Motor Assy.	8640-414-007	14

Rear View Photos

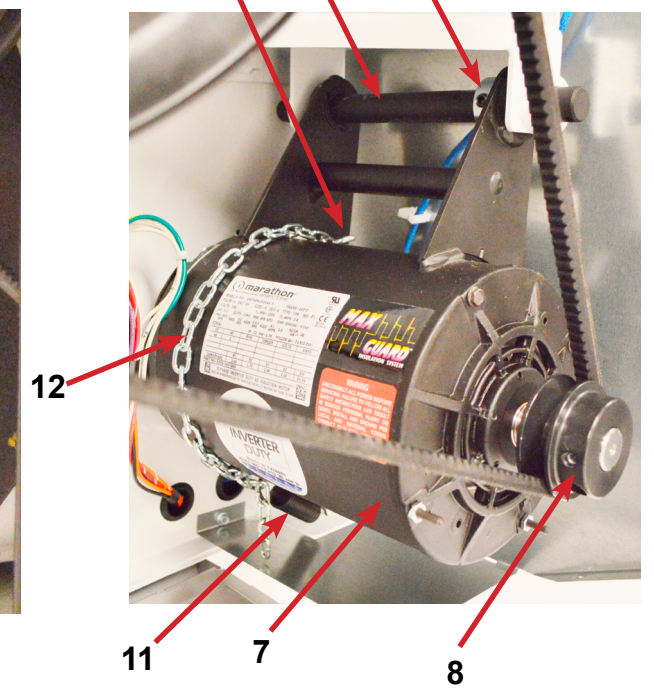
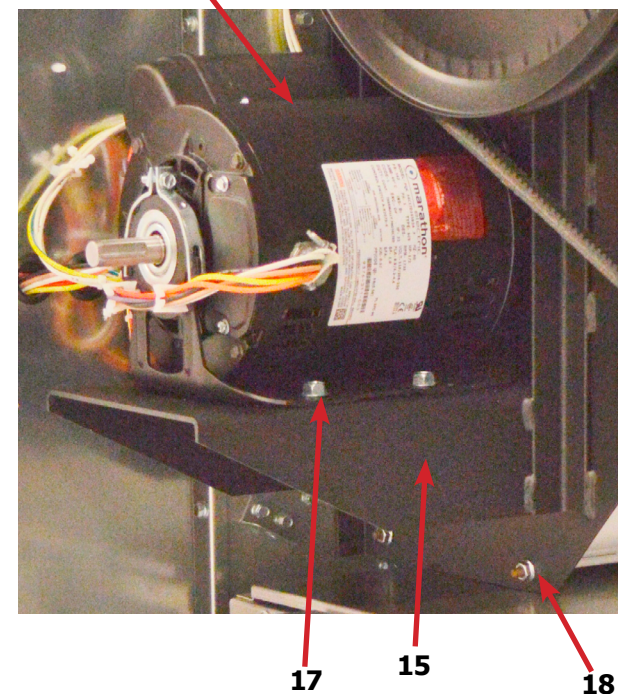
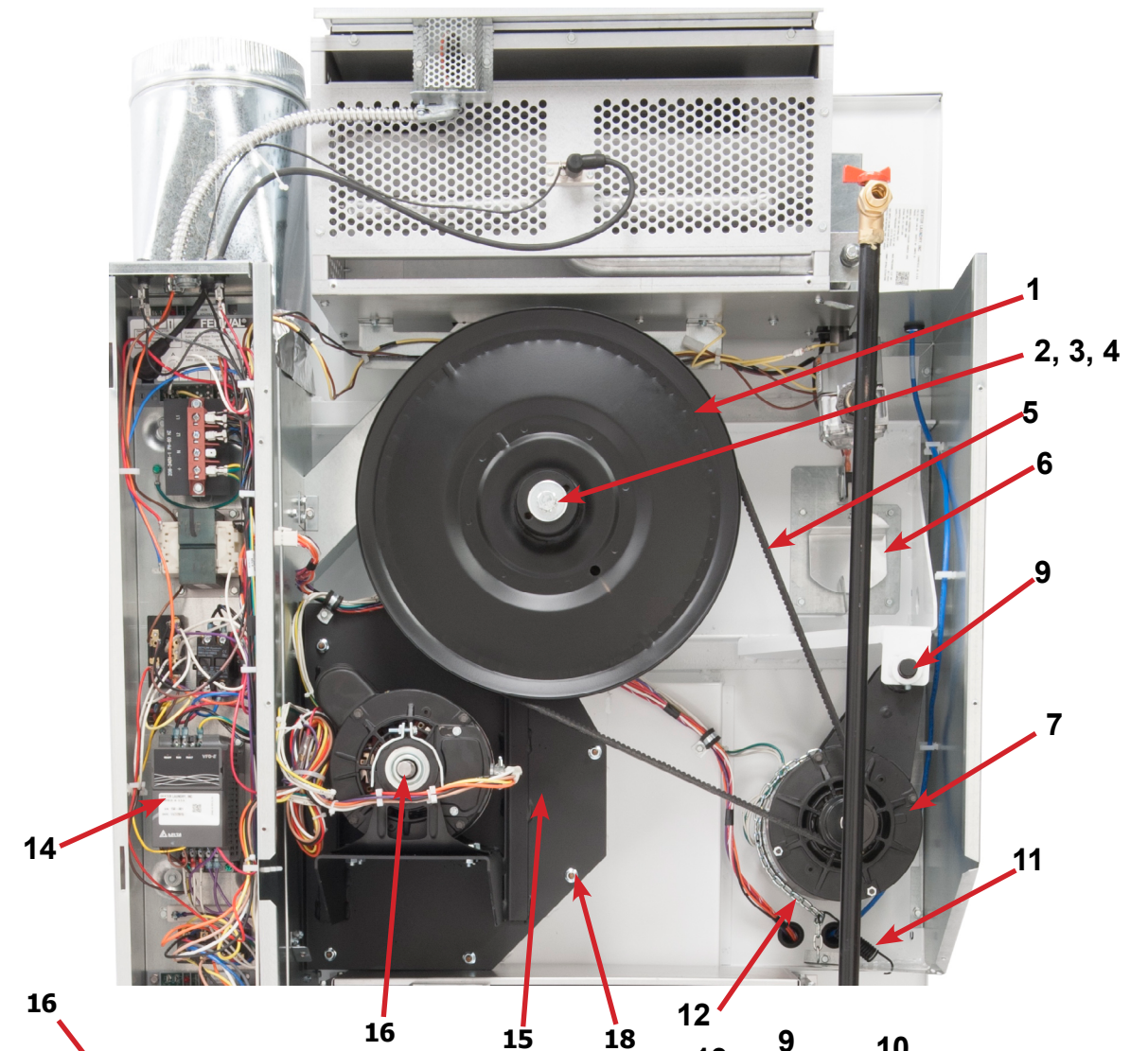

Bearing Housing Group

Key	Description	T-50X2-11 Reversing	QTY
	Bearing Housing Complete Assy (Includes bearings & Spacer)	9803-201-001	1
1	Housing, Bearing	9241-189-002	1
*	Bearing, Ball, Front	9036-159-001	1
*	Spacer, Bearing	9538-183-001	1
2	Bearing, Ball, Rear	9036-159-003	1
3	Screw-Wizlock, 1/2-13x3/4	9545-017-017	4
4	Nut, 1/2-13	8640-417-002	4
5	Screw, 1/2-13x1 1/2	9545-017-018	2

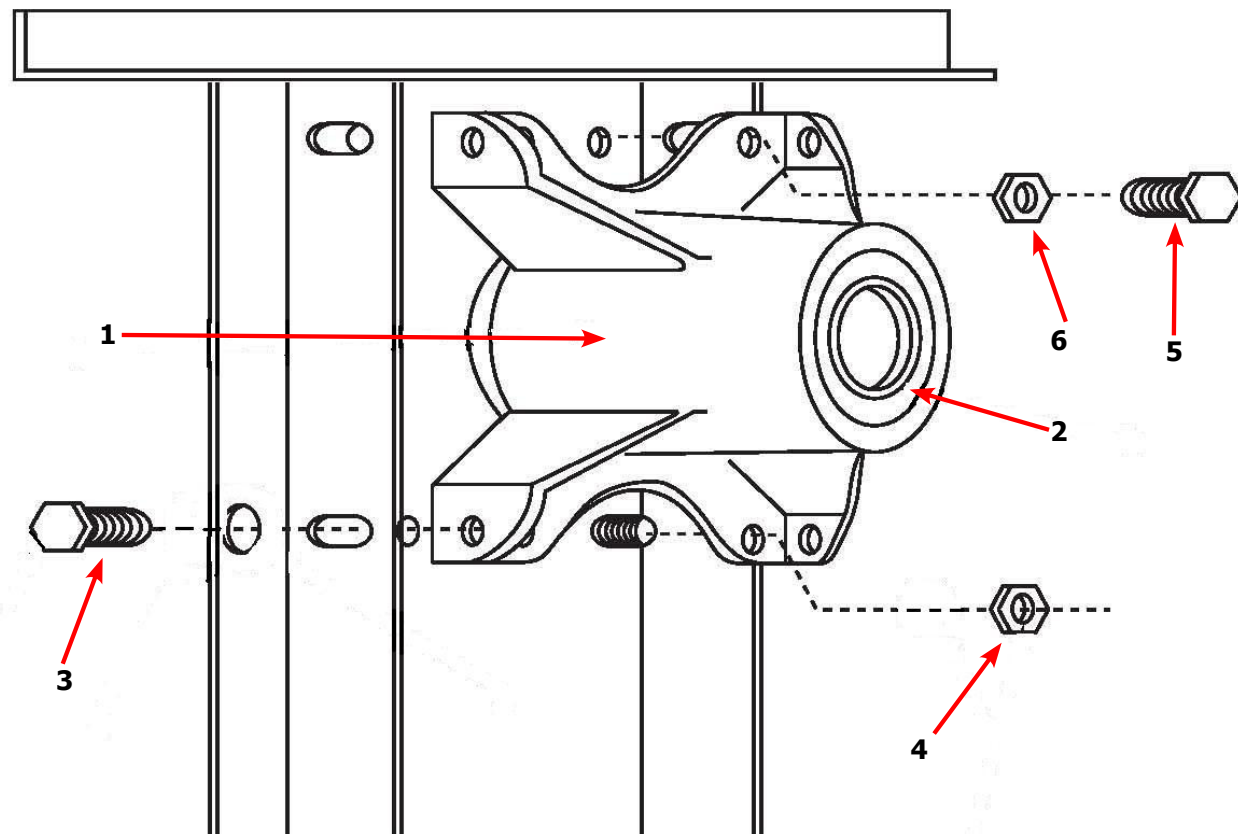
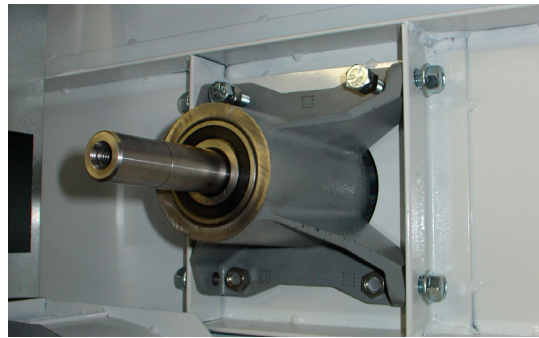

Tumbler Group

Key	Description	T-50X2-11 Reversing	QTY
*	Tumbler Assy Complete W/Spider (GALV)	9848-154-001	1
1	Tumbler Assy (Galvanized)	9848-148-001	1
*	New Tumbler, Taller Baffles (Anti-Roping) W/Spider	9848-158-001	1
*	New Tumbler, Taller Baffles (Anti-Roping)	9848-157-001	1
*	Tumbler Assy Complete W/Spider (SS & Galv front)	9848-154-002	1
1	Tumbler Assy (Stainless Galvanized front)	9848-148-002	1
2	Rod, Tumbler	9497-226-002	3
3	Washer, Special	8641-590-002	3
4	Shim	9552-013-003	AR
5	Spider Assy	9568-017-001	1
6	Nut, Wiz Lock	8640-417-005	3
7	Spacer-Shaft	9538-188-001	1
8	Tolerance Ring	9487-234-005	1
9	Pulley, Driven	9908-047-002	1
10	Washer -Flat	8641-581-026	1
11	LockWasher - IntTooth, 1"	8641-582-016	1
12	Screw, 1/2-13x1 1/4	9545-017-009	1
*	Belt, Drive	9040-076-003	2

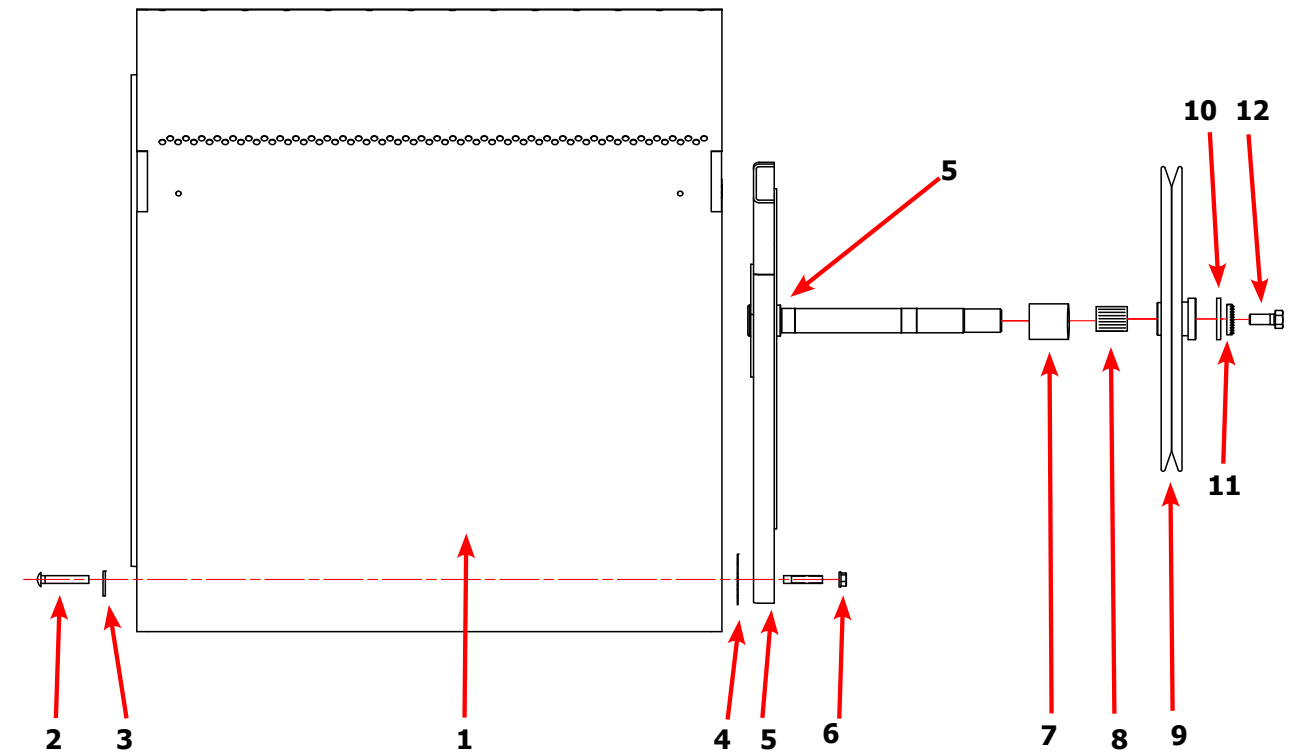

Burner Housing Group

Key	Description	T-50X2-11 Reversing	QTY
*	Housing Assembly, Burner	9803-230-001	2
1	Service Burner Plate Front	9452-730-001	2
2	Service Plate baffle Recirculation Chamber Clean Out	9452-850-001	2
*	Screw, 10B x 3/8"	9545-008-006	8
3	Screw, 10B X 1/4"	9545-008-001	16
4	Angle, Burner Support	9003-220-001	2
*	Screw, 10B x 3/8"	9545-008-006	4
5	Burner, Main	9048-020-002	4
*	Screw 10AB x 3/8"	9545-008-006	4
*	Panel, Burner- Front & Back	9454-822-001	2
6	Panel, Burner Housing, Side (RH)	9454-790-001	2
7	Panel, Burner Housing, Side (LH)	9454-826-001	2
8	Panel, Burner Housing, Top	9454-805-001	2
9	Shield-Heat, Burner Top	9550-198-001	2
10	Electrode Assy, Ignition	9875-002-003	2
11	Screw, Electrode Mtg 8B x 1/4"	9545-045-001	4
12	Valve, Gas Shut Off (Optional)	9379-196-001	1
13	Control Assy, Gas	9857-192-001	2
14	Manifold, Assy	9381-012-001	2
*	Orifice, Burner-Natural #29	9425-069-021	4
*	Orifice, Burner-LP #46	9425-069-022	4
15	Bracket, Manifold	9029-175-001	4
16	Pipe Plug in end of Burner Manifold	8615-104-038	2
*	Screw, 10B x 3/8"	9545-008-006	4
17	Thermostat, Hi-Limit	9576-203-002	2
*	Spacer, Hi-Limit	9538-142-001	2
*	Screw 8B x 3/4"	9545-045-007	6
18	Cover, Hi-Limit Stat Ignitor	9074-329-001	2
19	Bracket-Hilimit	9029-192-001	2
*	Screw, 10B x 3/8"	9545-008-006	4
*	Thermostat, Safety Shutoff	9576-207-008	2
*	Screw, 10B x 3/8"	9545-008-006	6
20	Cover, Safety Stat	9825-062-001	2
*	Screw, 10AB x 3/8	9545-008-024	6
*	Control, Ignition Fenwall (3 trybox)	9857-182-001	2
*	Kit, LP Conversion 50Lb Stack Kit (White Rodgers)	9732-102-045	1
*	Welded One Piece Gas Pipe Assembly w/Shutoff Valve	9838-018-003	1
*	Gas Pipe Assembly Replacement Kit	9732-360-003	1
*	Gas Pipe Assembly (After Serial)	9838-023-003	1
*	Fitting - 1/2 NPT Union Adapter	8615-120-001	1
21	Heat Recirculation Duct, (From Exhaust to Burner	9973-032-001	2
*	Screw, 10B x 3/8"	9545-008-006	8

Burner Housing Group Photos

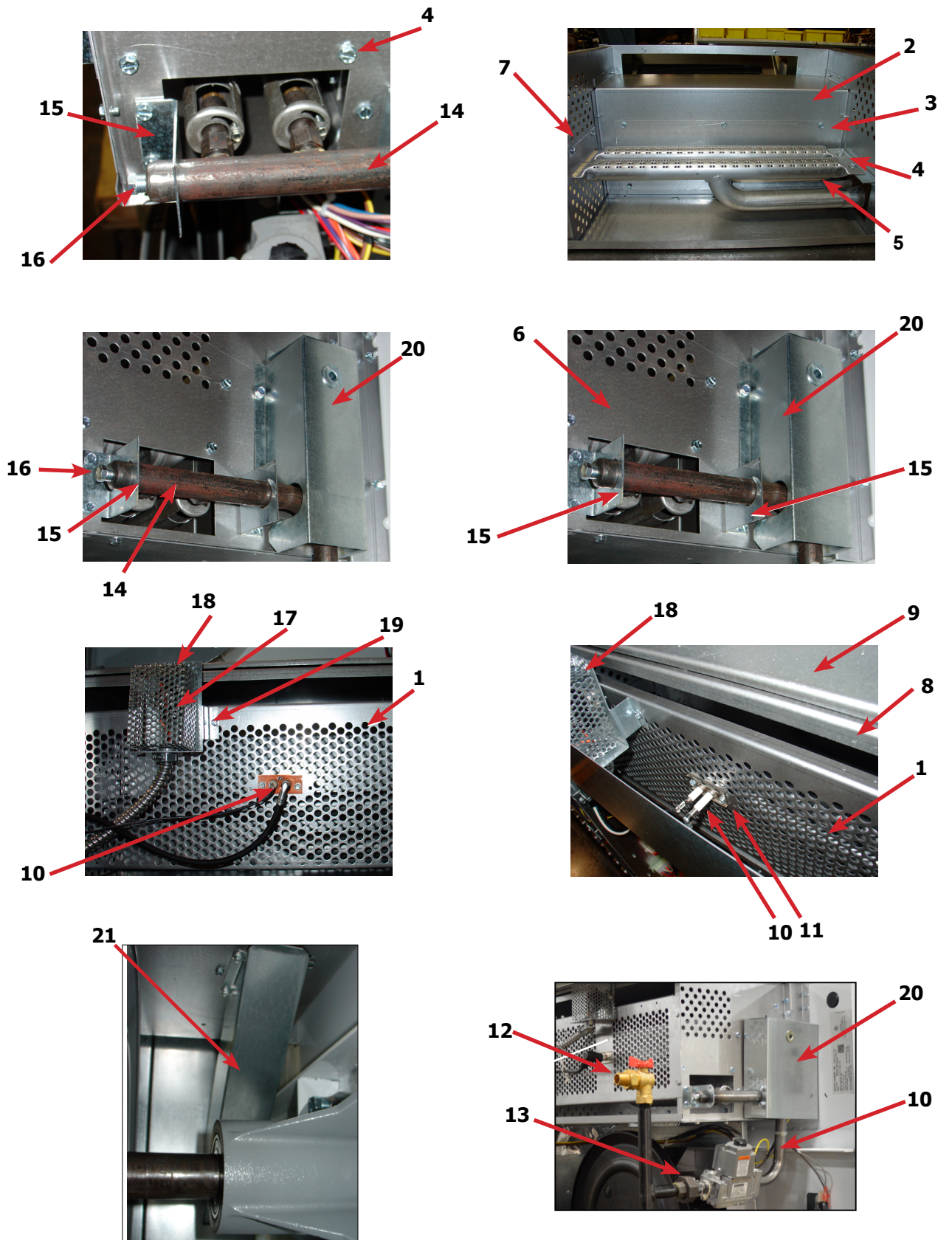

Air Flow Switch Assembly

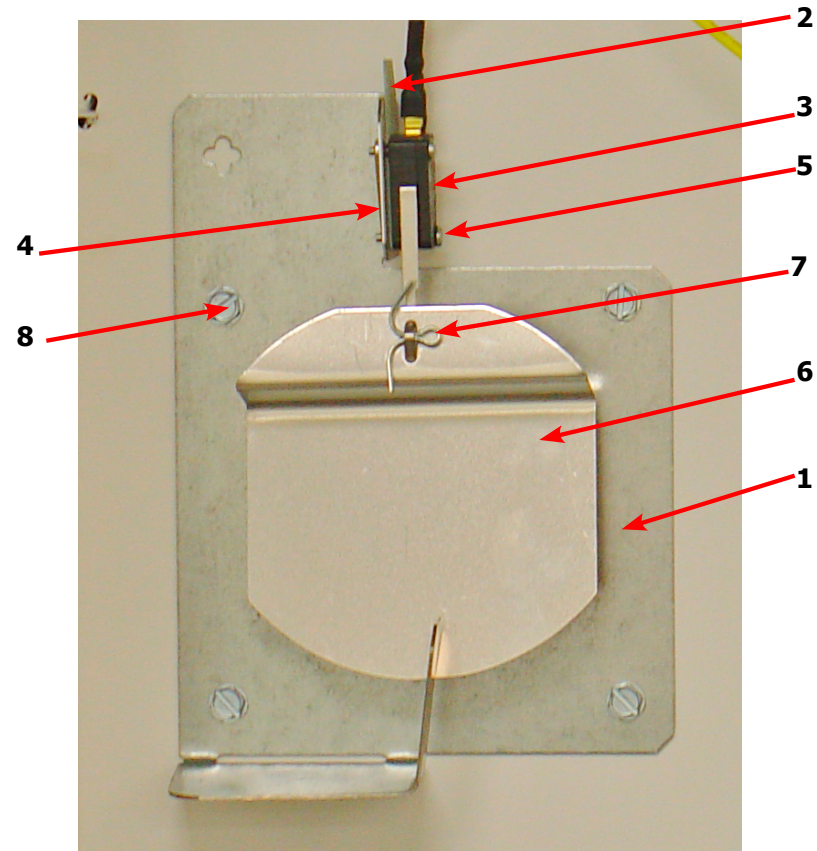

Key	Description	T-50X2-11 Reversing	QTY
*	Air Flow switch Assy	9801-098-001	2
1	Bracket-Airflow switch	9029-200-001	2
2	Shield-Switch	9550-169-003	2
3	Switch-Micro	9539-461-009	2
4	Nut-Twin, 4-40	8640-401-001	2
5	Screw-.625, 4-40	9545-020-001	2
6	Actuator-Air Flow Switch	9008-007-001	2
7	Pin-Cotter, .09375x.75	9451-169-002	2
8	Screw, 10Bx1/4	9545-008-001	8
*	Harness Assembly, Overtemp/Airflow	9627-861-001	1

OPL Control Board

Key	Description	T-50X2-11 Reversing	QTY
1	Control Assembly (Black)	9857-187-004	1
2	PCB Control Board	9471-017-001	1
3	PCB Display Board	9471-018-001	1
4	Cable, Upper Control Long	9500-007-001	1
5	Cable, Lower Control Short	9500-007-002	1
6	Membrane Switch Assembly (Black)	9801-110-001	1
7	Fuse, 600ma / 250V	8636-024-001	2
*	Harness Main Control OPL Stack Dryer	9627-885-002	1
8	Control Tray	9826-006-001	1

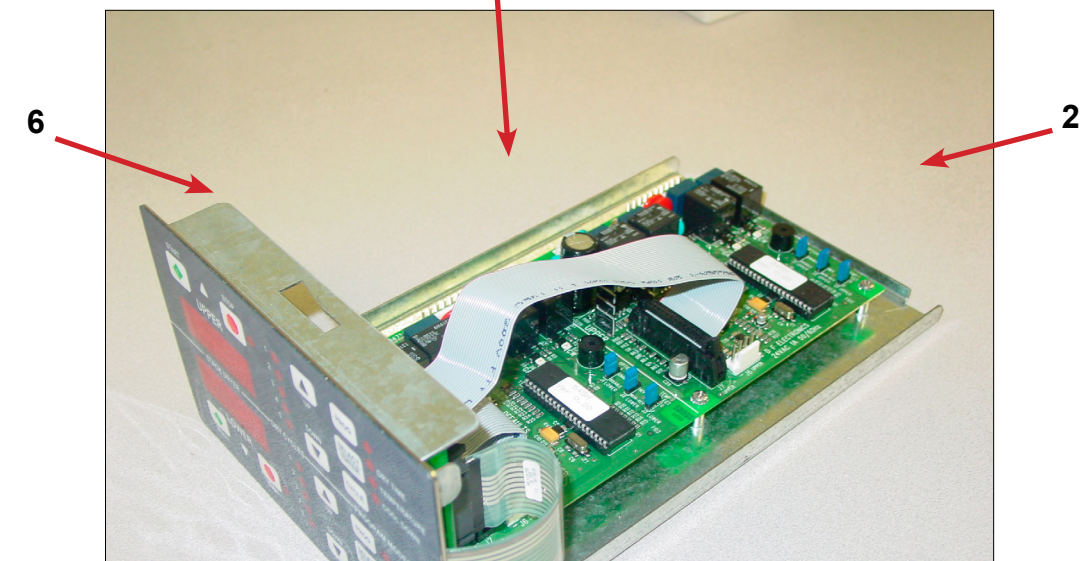
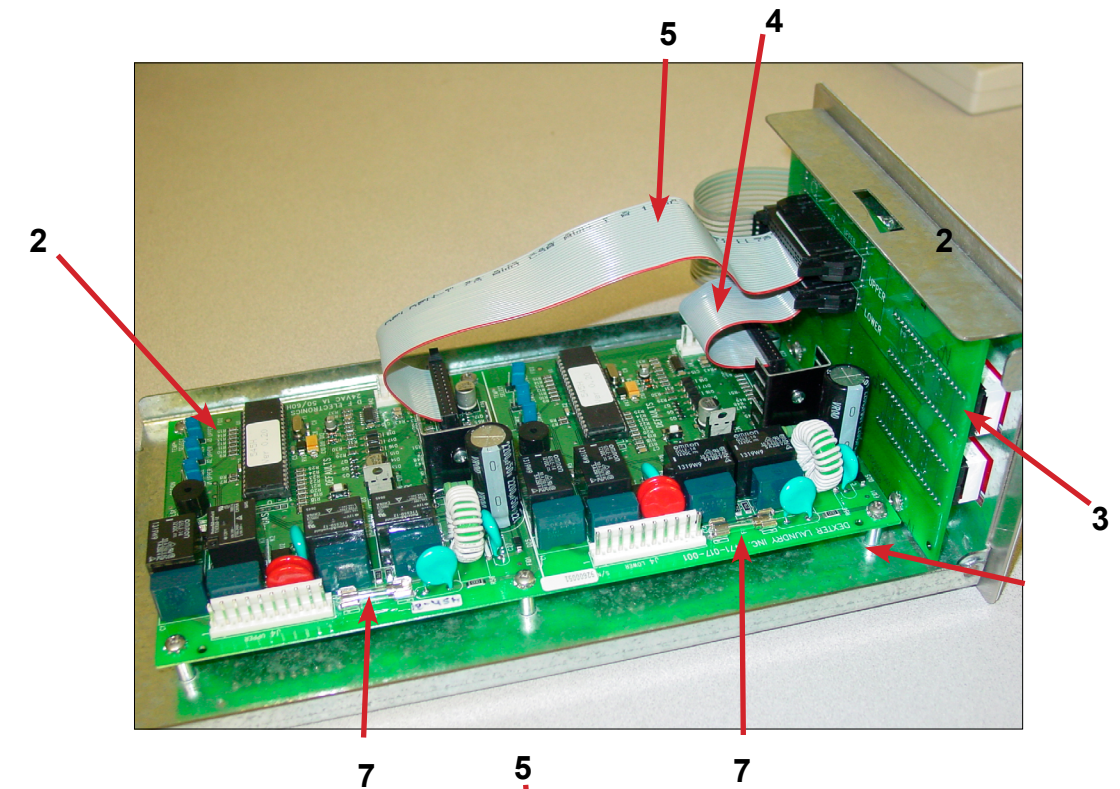

Control Assembly Group

Key	Description	T-50X2-11 Reversing	QTY
*	Control, Rear	9857-223-002	1
*	Bracket, Terminal Block Power	9029-202-001	1
1	Strip, Terminal Marker	9558-029-006	1
2	Terminal-Block, Power, 4 Pole	9897-035-001	1
*	Screw, 10AB x 3/8"	9545-008-024	1
*	Harness Assembly-Power Main Fork, Upper	9627-859-005	1
*	Harness Assembly-Power Main Fork, Lower	9627-859-006	1
3	Wire Assembly-Ground, GRN/YEL, 7"	8220-137-002	1
*	Lock Washer, Ext tooth	8641-582-006	1
4	Screw, 10-32 x 1"	9545-008-027	1
5	Transformer, 120/208/240/60Hz.(In), 24/120VAC (Out)	8711-013-001	1
6	Screw, 10AB x 3/8"	9545-008-024	4
7	Fuse Holder Assembly	9200-001-002	2
*	Fuse, 1.5Amp/250V-Fast Acting	8636-018-001	2
8	Relay, Motor, 30Amp 24VAC	5192-299-002	2
*	Screw, Phillips, 8AB x 1/2"	9545-045-012	4
9	Terminal Block Power	9897-026-002	1
*	Screw, Phillips, 8AB x 1/2"	9545-045-012	2
10	Relay-Enable, 24VAC 50/60Hz	5192-285-004	2
*	Screw, Phillips, 8AB x 3/8"	9545-045-008	4
11	Relay-Reversing, 24VAC 50/60Hz	5192-285-004	2
*	Screw, Phillips, 8AB x 3/8"	9545-045-008	4
12	Drive-Inverter, 230VAC,	9375-032-011	2
*	Screw-Mounting, 10B x 1/2"	9545-008-026	8
13	Key-Pad, Display, Delta E-Drive	9150-044-001	2
14	Resister-Dynamic Breaking, 2000Ohm	9483-004-002	2
*	Screw, 10AB x 3/8"	9545-008-024	4
*	Wire Assembly, Violet, 8"	8220-118-003	4
*	Screw, #6-32 x 5/16"	9545-044-006	4
*	Nut, Hexkeys, #6-32	8640-411-003	4
15	Terminal Block, Power	9897-026-003	2
*	Screw, Phillips, 8AB x 1/2"	9545-045-012	4
*	Harness-Assembly, Low Voltage, Upper	9627-867-007	1
*	Harness-Assembly, Low Voltage, Lower	9627-867-008	1
16	Ignition Module	9857-182-001	2
*	Screw, 10AB x 3/4"	9545-008-018	4
17	Wire Assembly, High Voltage	9631-403-009	2
*	Harness Extension (Internal)	9627-887-002	1
*	Harness Extension (External)	9627-885-002	1
*	Harness, Overtemp & Air flow switch	9627-861-001	2
*	Door-Control Box	9108-139-001	1
*	Screw, 10AB x 3/8"	9545-008-024	3

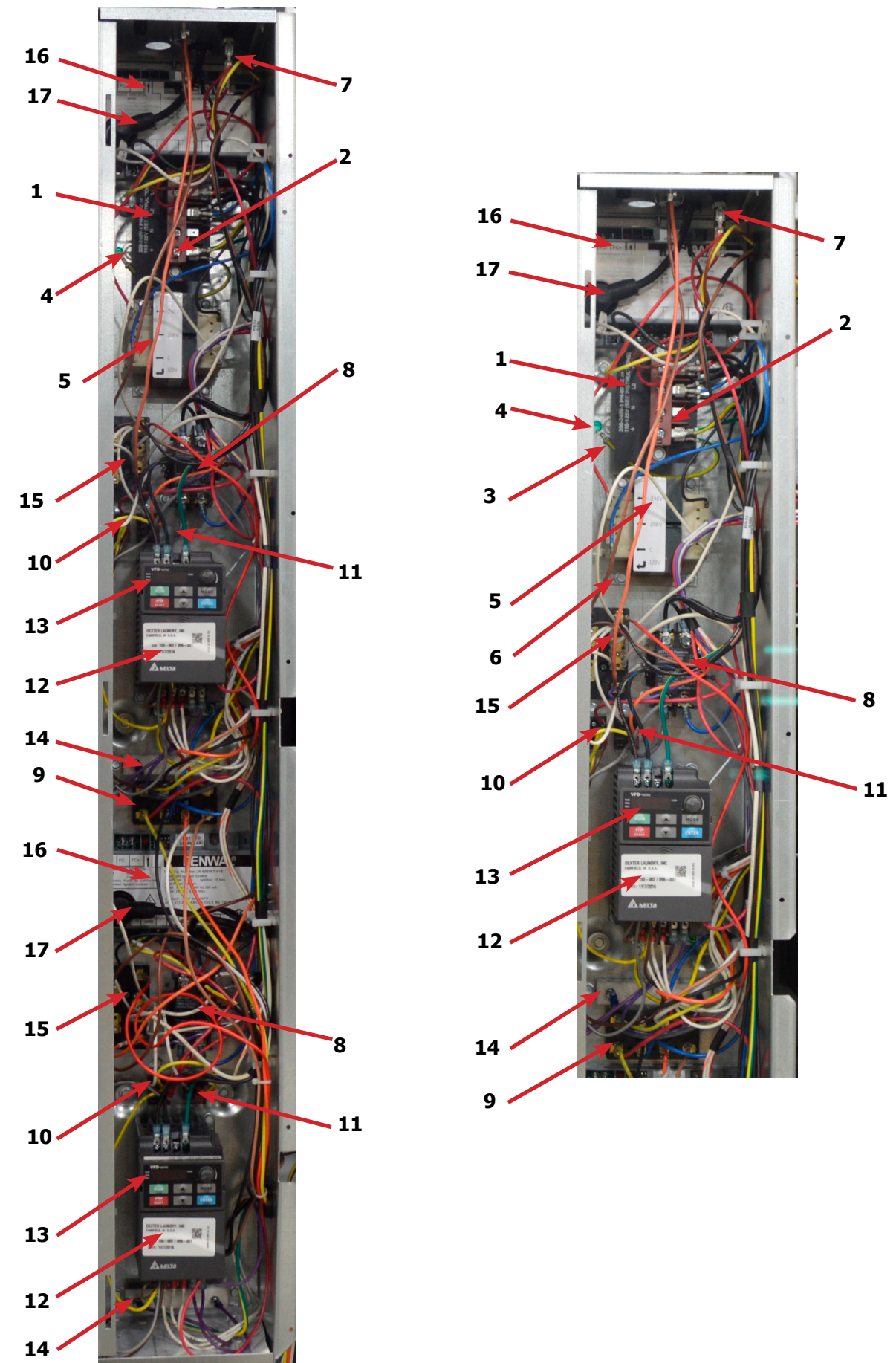

Sensor Assembly, Thermistor

Key	Description	T-50X2-11 Reversing	
*	Bracket for Heat Sensor Mounting (Under Basket) w/ sensor	9501-008-002	2
1	Bracket Assembly Thermistor	9985-188-001	2
2	Gasket spacer	9206-176-000	2
3	Grommet	9209-037-002	2
4	Screw, 8B x 14	9545-045-005	2
5	Sensor-Heat, Thermistor- 10K Ohm	9501-004-004	2
*	Screw-Mounting, 10AB x 3/8	9545-008-024	2

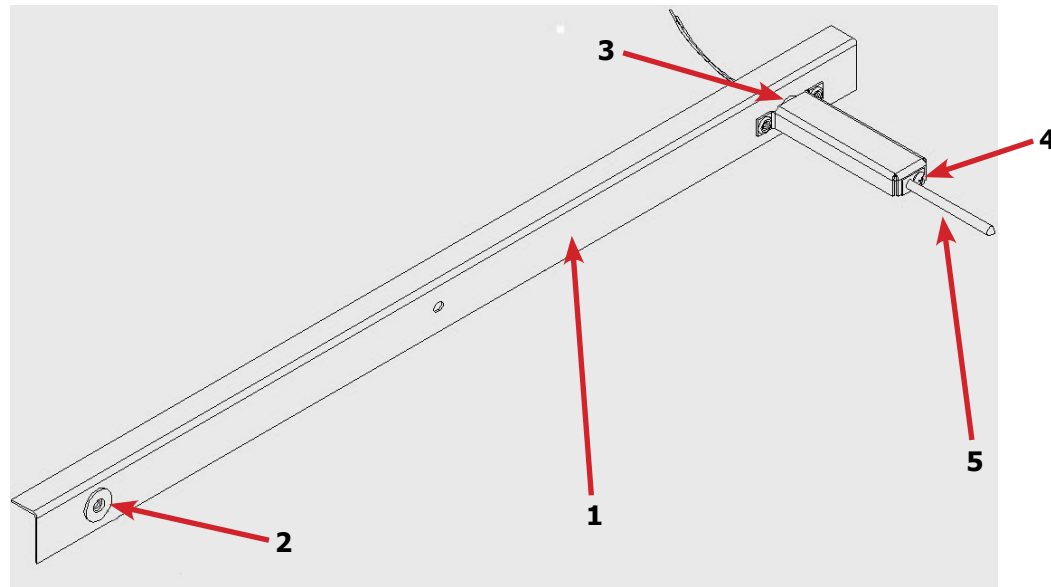

Wiring Schematic for DN50x2 Reversing

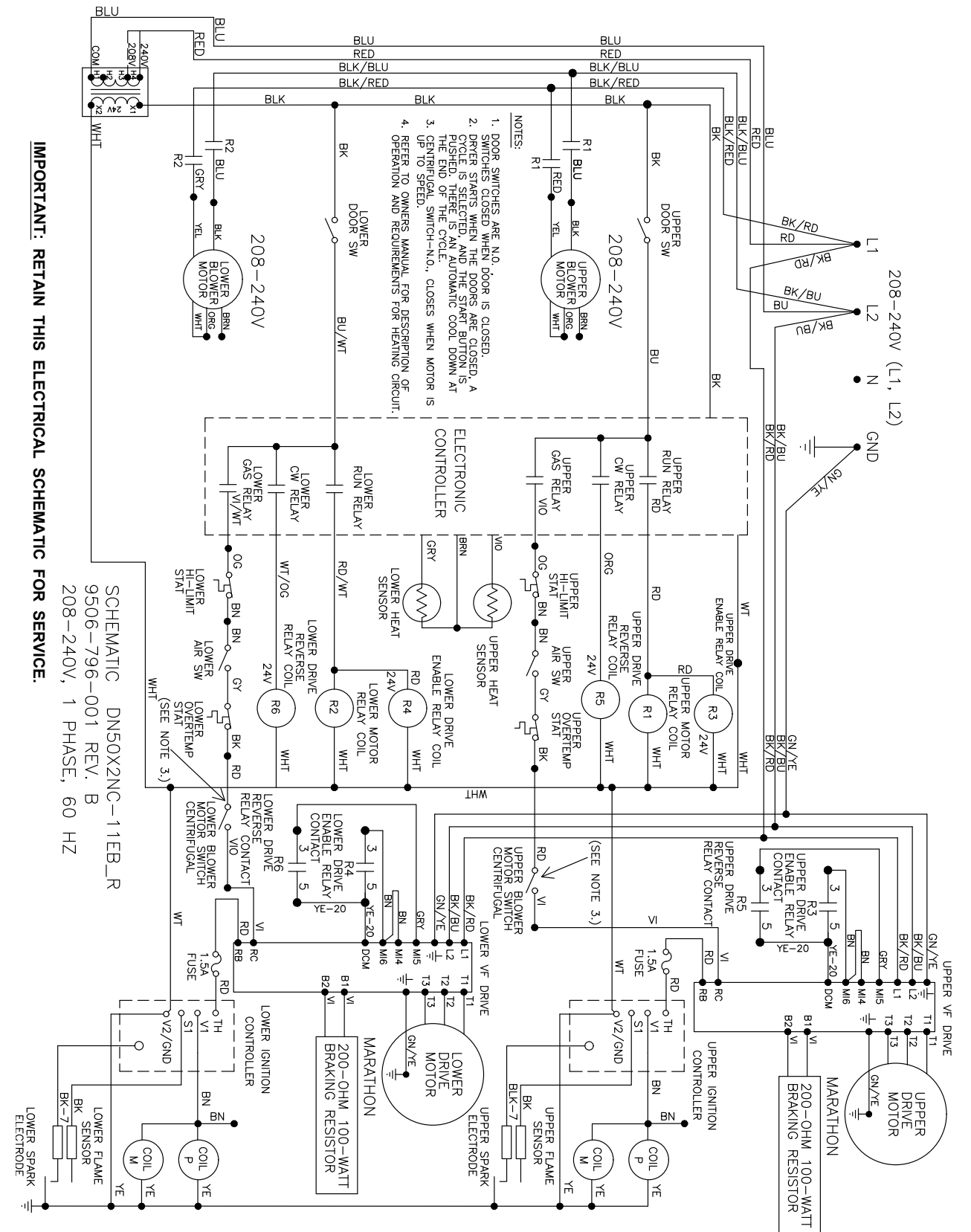

Section 8:

50Hz. Parts

Data 50# Stack

Rear View Photos

Key	Description	T-50X2-39 Reversing	QTY
*	Spacer, Tumbler pulley	9538-047-002	2
1	Pulley, Driven	9908-047-002	2
*	Tolerance Ring	9487-234-005	2
2	Washer-Flat, 1/2"	8641-581-026	2
3	Lock Washer, 1/2"	8641-582-016	2
4	Bolt, 1/2"-13 x 1" 1/4"	9545-017-009	2
5	Belt, Drive	9040-076-003	2
6	Air Flow Switch, Assembly	9801-098-002	2
7	Motor-Drive, 2Hp.	9376-319-001	2
8	Pulley-Motor, Drive	9453-169-012	2
*	Screw-Set, 5/16"-18 x 1/2"	9545-028-013	4
9	Rod-Motor Mounting	9497-222-008	2
*	Bushing, Motor Support	9053-074-002	4
10	Collar-Shaft, w/Set Screw	9076-052-002	2
11	Spring, Belt Tension	9534-319-002	2
12	Chain, Spring Tension, 15 1/2" (27 Links)	9099-012-008	2
13	Hook, "S" Hook	9248-022-002	2
14	Drive-VF, Inverter, 2Hp 230VAC	9375-032-011	2
*	Assembly, Impeller-Blower Motor (15-17)	9919-019-002	2
15	Plate Assembly, Impeller-Blower Motor	9982-388-002	2
*	Nut, 5/16"-18	8640-400-003	8
*	Impeller, w/Set Screws	9278-043-001	2
16	Motor, Blower, 50HZ.	9376-311-004	2
17	Bolt-Motor Mounting, 5/16, 18 x 5/8"	9545-014-004	8
18	Nut-1/4" x 20, Mounting Plate, Impeller Motor Assy.	8640-414-007	14

Rear View Photos

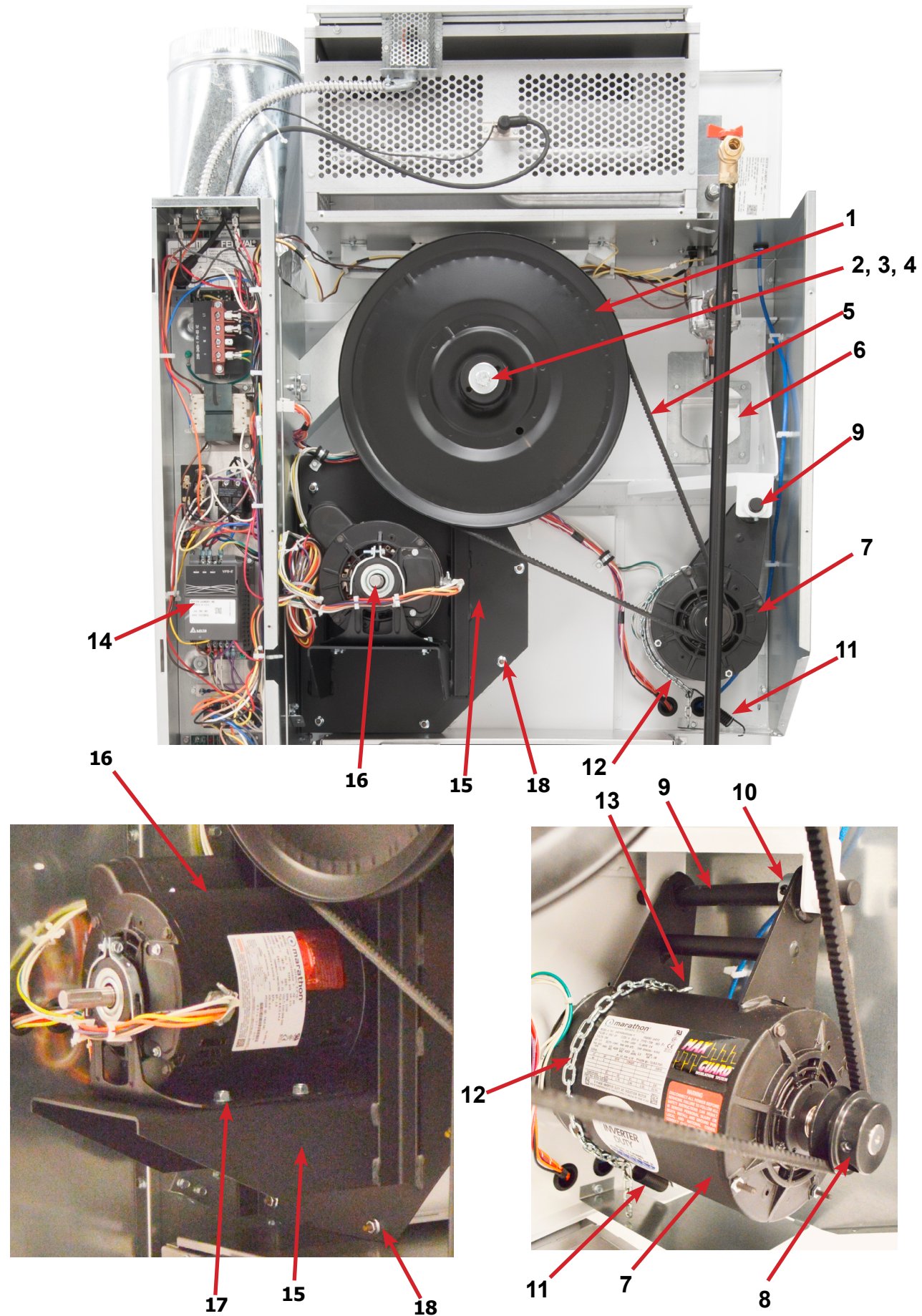

Electrical Components

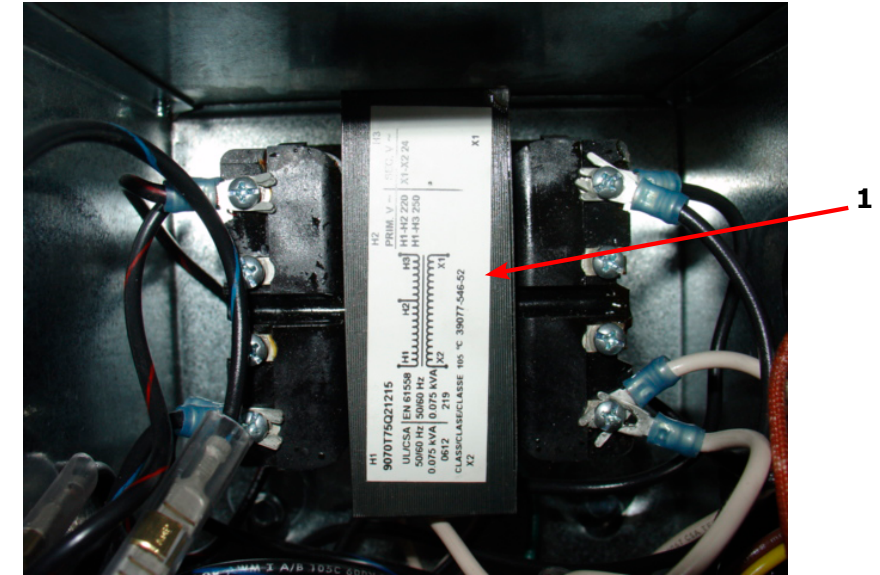

Key	Description	T-50X2-39 Reversing	QTY
1	Transformer, 200/230-24 VAC, 50/60HZ	8711-004-004	1
*	Strip-Marker, Terminal	9558-029-004	1

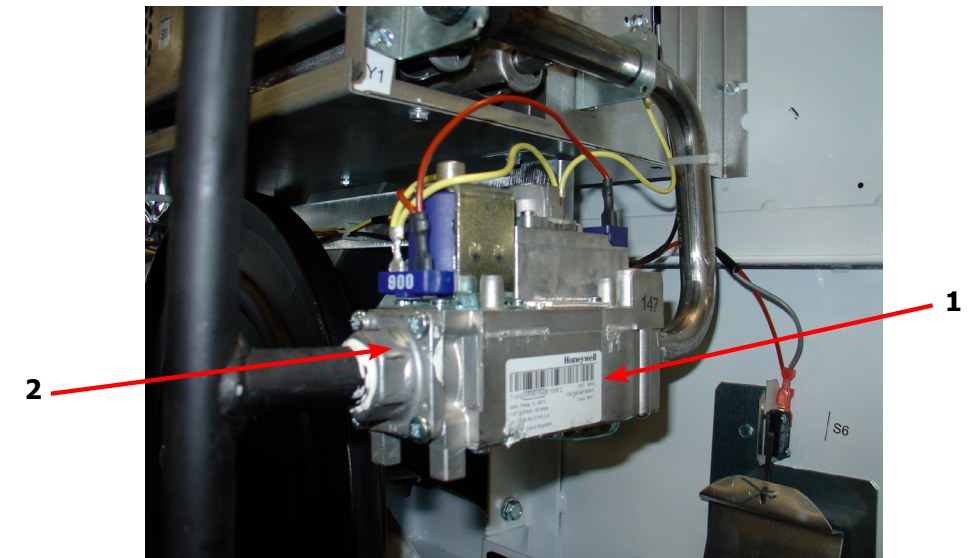

Key	Description	T-50X2-39Reversing	QTY
1	Control Assembly, Gas Valve	9857-132-004	2
2	Kit-Honeywell VR86, Valve Flange assy	9732-162-001	4
*	Orifice, Main Burner, #30	9425-069-002	4

Air Flow Switch Assembly

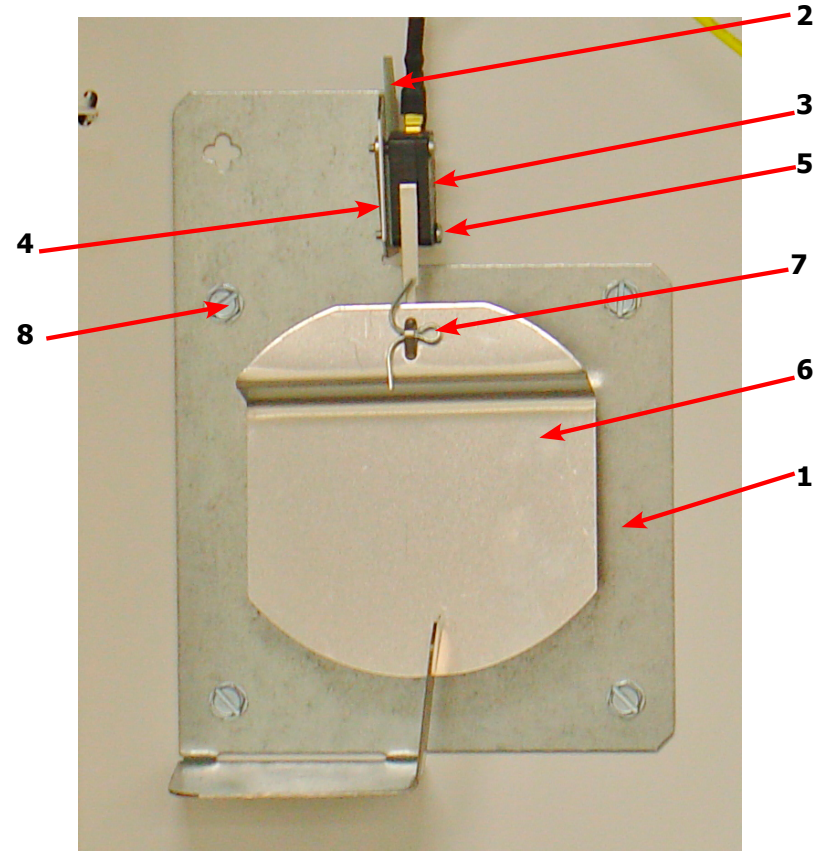

Key	Description	T-50X2-39 Reversing	QTY
*	Air Flow switch Assy	9801-098-002	2
1	Bracket-Airflow switch	9029-200-002	2
2	Shield-Switch	9550-169-003	2
3	Switch-Micro	9539-461-009	2
4	Nut-Twin, 4-40	8640-401-001	2
5	Screw-.625, 4-40	9545-020-001	2
6	Actuator-Air Flow Switch	9008-007-001	2
7	Pin-Cotter, .09375x.75	9451-169-002	2
8	Screw, 10Bx1/4	9545-008-001	8
*	Harness Assembly, Overtemp/Airflow	9627-861-001	1

Wiring Schematic for DN50x2 Reversing 50Hz.

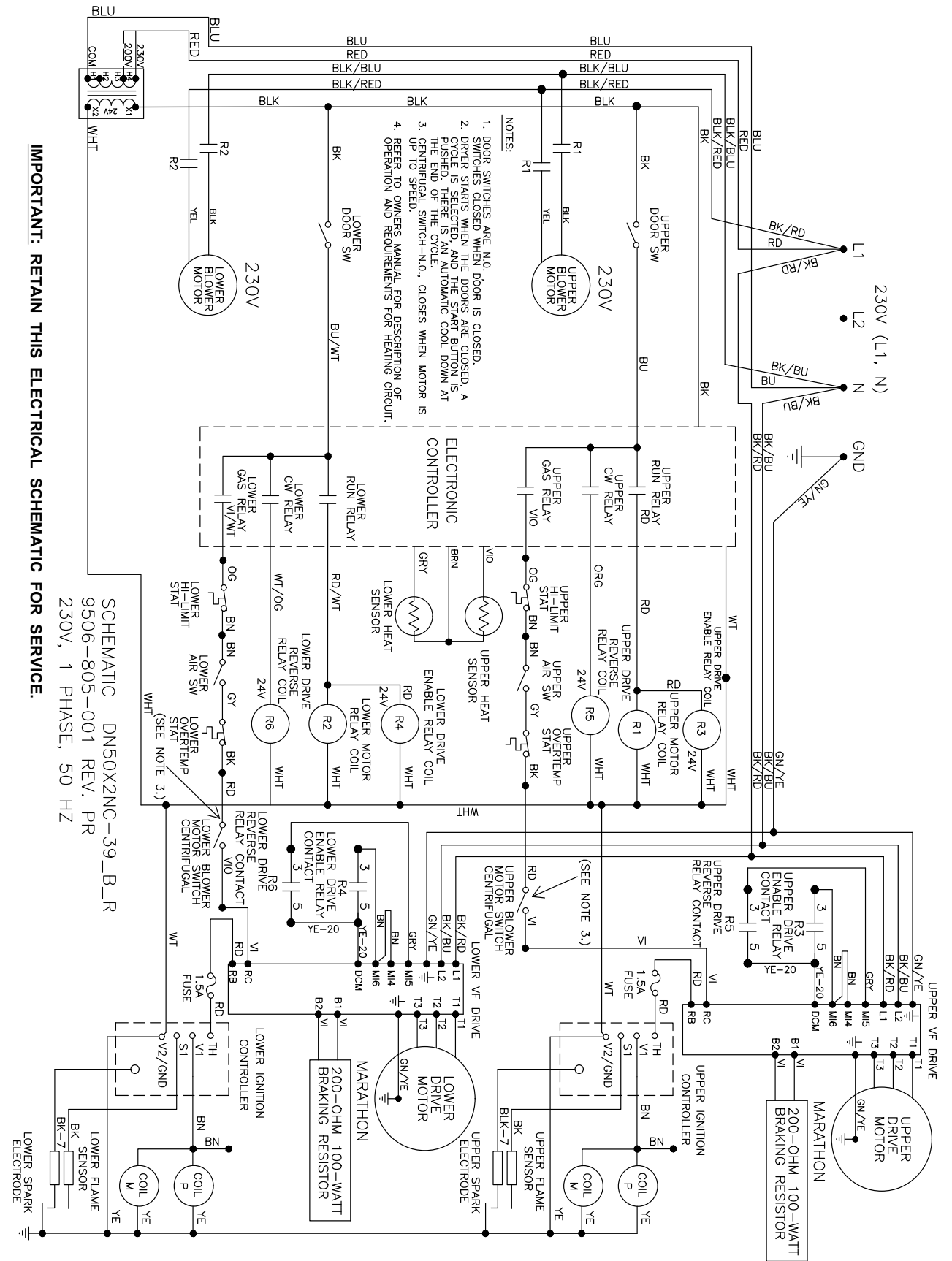

Preventative Maintenance

Daily

- Step 1:** Clean the lint screen free of lint and other debris. Use a soft brush and Hot water if necessary.
- Step 2:** Check the lint screen for tears. Replace if necessary.
- Step 3:** Clean lint from the lint screen compartment.
- Step 4:** Inspect felt seal on lint screen assembly, replace if needed.

Monthly

- Step 1:** Remove lint accumulation from the end bells of the motor.
- Step 2:** Remove lint accumulation from front control area.
- Step 3:** Remove lint and dirt accumulation from the top of the dryer and all areas above, below, and around the burners and burner housing. Failure to keep this portion of the dryer clean can lead to a build-up of lint creating a fire hazard.
- Step 4:** Remove and clean coin acceptors. (Vended Models Only)

Quarterly

- Step 1:** Check the belts for looseness, wear, or fraying.
- Step 2:** Inspect the gasket of the door glass for excessive wear.
- Step 3:** Check tightness of all fasteners holding parts to support channel.
- Step 4:** Check tightness of all set screws.
- Step 5:** Remove the air flow switch assembly and check the tumbler thru-bolts for tightness.
- Step 6:** Apply a few drops of oil to pivot pins and the tension arms where in contact with each other.

Semi-Annually

- Step 1:** Remove and clean the main burners.
- Step 2:** Remove all orifices and examine for dirt and hole obstruction.
- Step 3:** Remove all lint accumulation. Remove the front panel and the lint screen housing and remove lint accumulation.

Annually

- Step 1:** Check the intermediate pulley bearings for wear.
- Step 2:** Check and remove any lint accumulation from the exhaust system including recirculation chambers if applicable.
- Step 3:** Grease the bearings and the shaft of the intermediate pulley. Use an Alemite grease gun and Molykote BR2-S grease. (Where applicable)