



DEXTER[®]
LAUNDRY

**USE THE BLUE TABS LOCATED ON THE
RIGHT AND LEFT SIDES OF THE FOLLOWING
DOCUMENT TO ADVANCE TO EACH SECTION.**

Kits, Assemblies, & Common Parts

Coin Acceptor Components	Part Number
Optical Coin Acceptor	9021-092-002
Optical Sensor Replacement	9801-099-001
Coin Drop Screws	9545-053-002
Retainer, Coin Acceptor	9486-149-001
Loading Door Components	Part Number
Door Handle	9244-093-001
Door Close Switch	9539-487-001
Electrical Components	Part Number
Relay, Motor Run (24VAC)	5192-299-002
Transformer, Ignition/Control (24VAC)	8711-013-001
Transformer, Ignition/Control (120VAC)	8711-011-001
Controls 24VAC (Blue)	9857-198-002
Controls 24VAC (Black)	9857-198-004
Heating Circuit Components	Part Number
Ignition Control Module	9857-182-001
Ignition Electrode Assembly	9875-002-003
Thermostat, Hi-Limit	9576-203-002
Thermostat, Overtemp	9576-207-008
Fuseholder	9200-001-002
Fuse 1.5 amp	8636-018-001
Airflow Switch	9539-461-009
Cabinet Components	Part Number
Cleanout Duct Assembly 8"	9973-034-001



Section: 7

Parts Data

DC30X2

24VAC Control

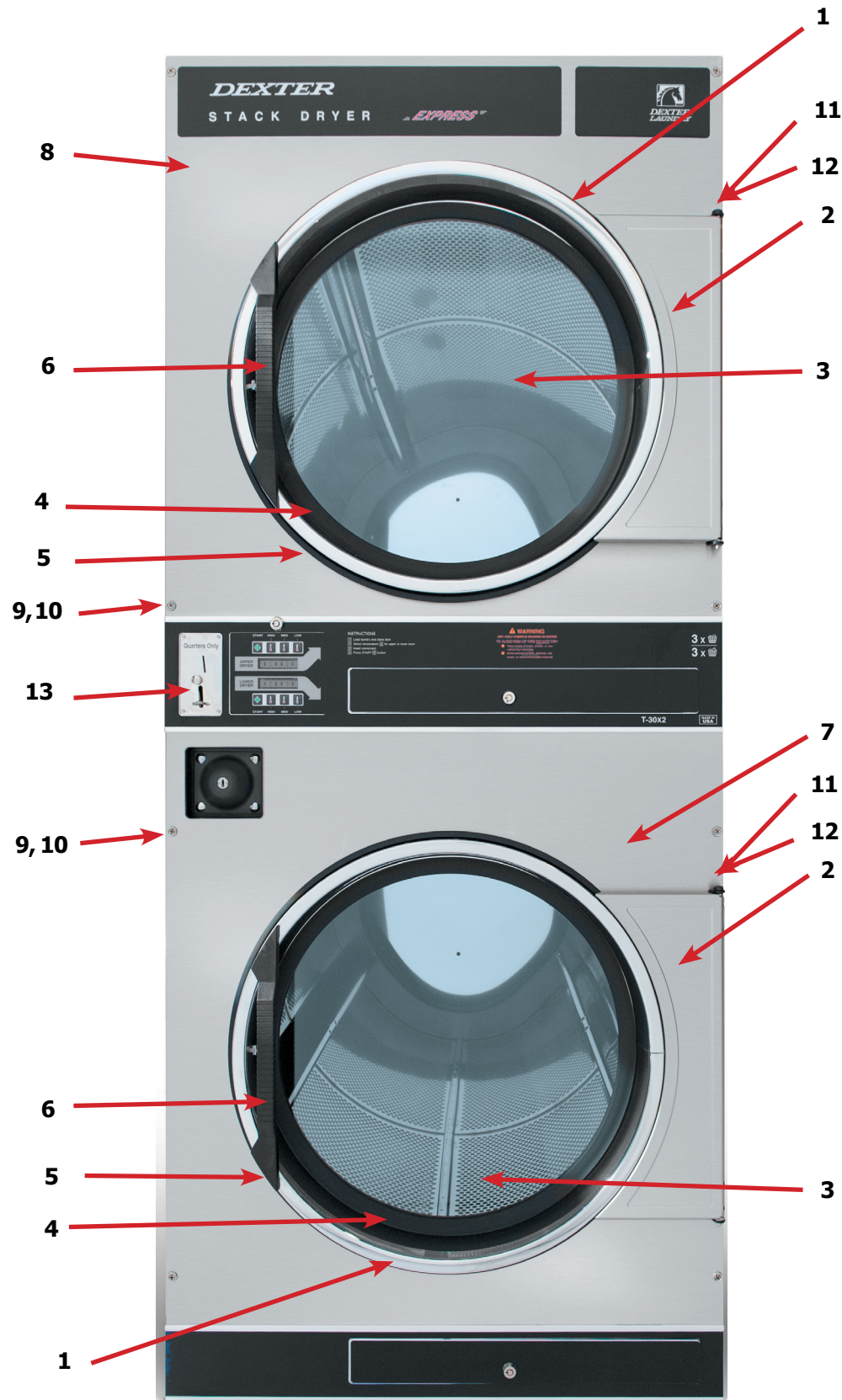

Parts Data

Cabinet Group

Key	Part Number	Description	Quantity
*	9960-256-038	Door Assy., Loading Complete-Wht	2
*	9960-256-039	Door Assy., Loading Complete-SS	2
*	9960-256-035	Door Assy., Loading Complete-Chrome SS/CHR/BLK	2
1	9960-255-008	Door Assy., Loading-SS(ring only)	2
1	9960-255-016	Door Assy., Loading-Chrome(ring only)	2
2	9982-280-014	Plate Assy., Hinge (Wht) No Pin	2
2	9982-280-012	Plate Assy., Hinge (SS) No Pin	2
*	9545-012-015	Screw, Hinge to Door	8
*	8640-413-002	Nut, Hinge to Door	8
3	9212-002-003	Glass, Door	2
4	9206-413-001	Gasket, Glass, Black	2
*	9548-117-000	Support, Door Glass	2
*	8545-064-001	Tool Install Dryer Glass Gasket	1
5	9206-420-003	Gasket, Outer Rim Black	2
6	9244-082-001	Handle, Loading Door	2
*	9545-018-017	Screw, Handle 1/4-20 x 3/8	2
*	9531-033-001	Stud, Door Catch	2
*	8640-413-001	Nut, Hex	2
*	8640-413-003	Nut, Acorn	2
*	9086-015-002	Catch, Loading Door	2
*	8638-190-009	Pop Rivet for mtg. catch	4
*	8641-582-006	Lockwasher	4
*	8640-399-001	Spring Nut	6
*	8640-442-001	Nut Expansion (After Serial D1.21180.032)	8
7	9989-569-003	Panel Assy., Front- Lower (Wht) (LRG Vault)	1
7	9989-569-001	Panel Assy., Front- Lower (SS) (LRG Vault)	1
8	9989-568-003	Panel Assy., Front- Upper (Wht)	1
8	9989-568-001	Panel Assy., Front- Upper (SS)	1
9	9545-008-014	Screw Phillips 10B x 1 3/4"	8
10	8641-585-001	Washer Finish	8
11	9544-072-002	Strap, Hinge (Black)	2
*	9452-819-001	Plate Hinge Backup	2
*	9545-012-028	Screw, Hinge to Panel	8
12	9545-052-001	Screw, Door to Hinge Strap (Special Black Type)	2
*	8641-436-003	Washer, Fiber	2
13	9021-041-001	Acceptor-Coin, Optical	1
*	9486-149-001	Retainer, Coin Acceptor	2
14	9545-053-002	Screw	4
*	9801-099-001	Switch, Optical (Replacement)	1
*	9472-001-013	Cabinet Touch Up Paint (White)	1

Cabinet Group Continued

Key	Part Number	Description	Quantity
14	9994-046-001	Escutcheon, Upper	1
15	9435-061-002	Trim, Overlay-Upper, Blue (After Serial D1.19217.025)	1
15	9435-061-001	Trim, Overlay-Upper, Black (After Serial D1.19217.025)	1
15	9435-037-002	Trim, Overlay-Upper, Blue (Before Serial D1.19217.025)	1
15	9435-037-001	Trim, Overlay-Upper, Black (Before Serial D1.19217.025).....	1
*	9545-020-009	Screw, #4-40 x 3/16.....	10
16	9994-048-001	Escutcheon, Lower	1
17	9435-063-002	Trim, Overlay-Lower, Blue	1
17	9435-063-001	Trim, Overlay-Lower, Black.....	1
*	9545-020-009	Screw, #4-40 x 3/16.....	10
18	9412-167-002	Nameplate Stack Dryer Express, Blue	1
18	9412-167-001	Nameplate Stack Dryer Express, Black	1
19	8650-012-004	Lock and Key, Lint Drawer #6101	2
*	6292-006-010	Key 6101 only for Lint Drawer	AR
*	9095-043-001	Cam, Lock Lint Drawer	2
*	9627-859-003	Harness, Main-Electronic Control	1
20	9857-198-002	Controls Assy, 24V, BLU	1
20	9857-198-004	Controls Assy, 24V, BLK	1
21	9435-038-002	Overlay-Control, Blue	1
21	9435-038-001	Overlay-Control, Black	1
22	8650-012-003	Lock and Key, Control #6324	1
*	9095-041-001	Cam, Lock	1
*	6292-006-007	Key 6324 only for Computer.....	1
*	9150-045-001	USB, Thumbdrive.....	1
*	9627-855-001	Harness, Heat Sensor.....	1
*	8640-276-002	Wire Nut Connector Grey.....	4
23	9501-006-001	Sensor Temp Control (serial #200588).....	2
24	9486-137-002	Retainer - Push On.....	2
*	9209-037-002	Grommet, 3/16 ID	2
25	9866-004-001	Lint Drawer Assembly, Blue	2
25	9866-004-011	Lint Drawer Assembly, Black	2
26	9435-003-009	Overlay trim, lint drawer, Blue	1
26	9435-029-001	Overlay trim, lint drawer, Black.....	1
*	9532-143-001	Felt Seal (back of lint screen assembly)	2
*	9805-038-001	Lint Screen Assembly ONLY (no front)	2
*	9555-057-002	Replaceable Lint Screen Only	2
*	9545-008-001	Screws 10Bx 1/4 Lint Screen Strap Hold Down	32
*	8544-006-001	Leg, Leveling 1/2"	4
*	8545-061-002	Leveling Leg Wrench	1
*	9074-365-001	Cover, Cabinet (Top).....	1
*	9277-041-011	Insulation Cabinet Cover	1
*	9732-253-001	DDAD Kit for Dryers without Neutral and using 208-240 volt	1
*	9732-102-011	LP Kit for DDAD Dryers.....	1
*	9555-057-003	Replaceable Lint Screen Fine Mesh Only	1
*	9277-063-001	Insulation-Front Panel-Top Half	2
*	9277-063-002	Insulation-Front Panel-Lower Half.....	2
*	9527-007-001	Standoff Wire Saddle.....	8
*	9544-041-002	Strap - Bead Tie.....	1
27	9942-038-005	Vault, Coin Box	1
*	9545-008-024	Screws, Mounting-Coin Vault	2
28	9807-099-002	Coin Box Assy, Large Blue	1
28	9807-099-004	Coin Box Assy, Large Black	1
*	8640-413-004	Nut, Elastic Stop.....	

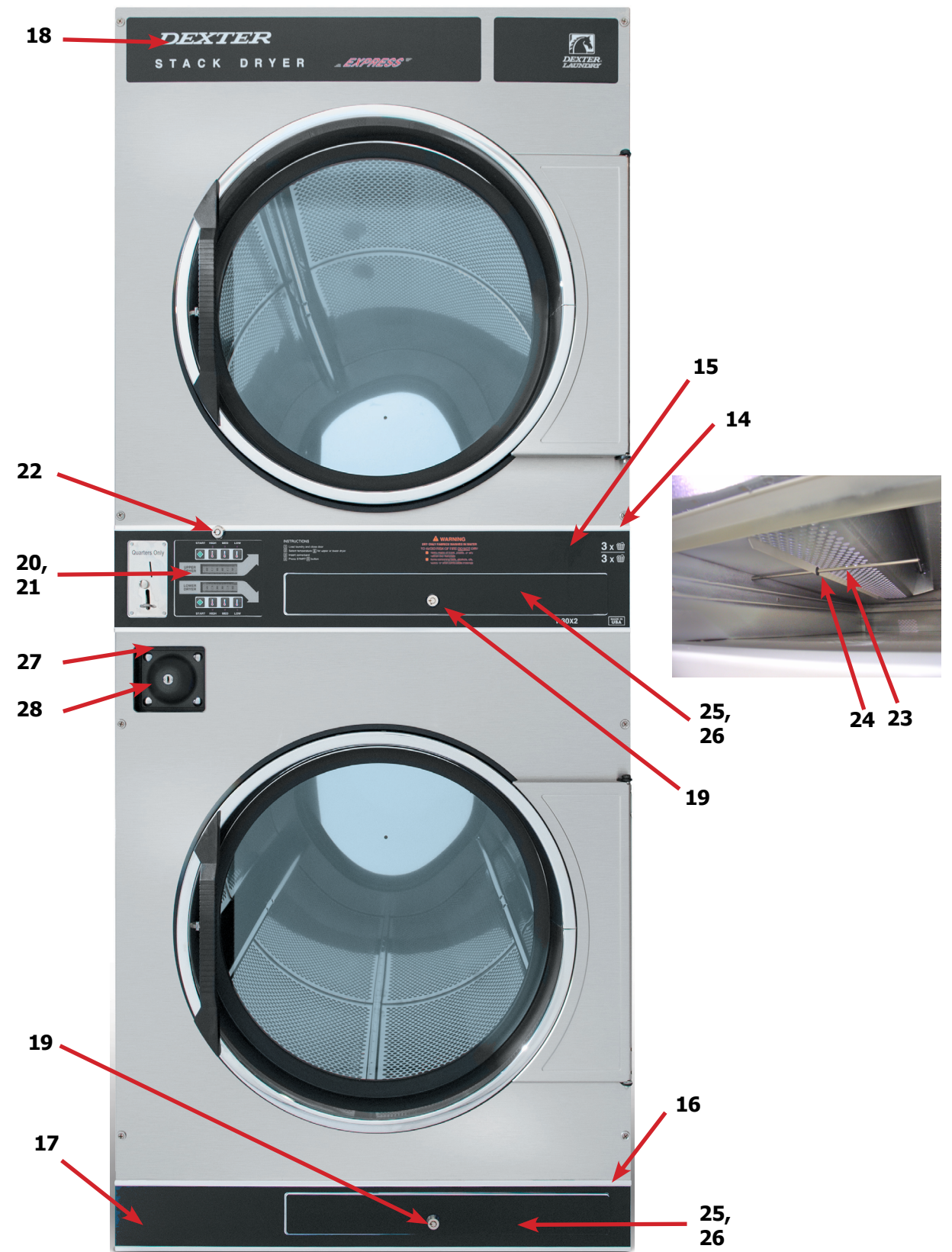

Modular Cabinet Group (After Serial D1.24108.023)

Key	Part Number	Description	Quantity
1	9945-167-001	Cabinet Base Assembly.....	1
*	9989-732-002	Back Panel Assembly.....	2
2	9989-733-003	Lower RH Side Panel Assembly	1
3	9989-733-004	Lower LH Side Panel Assembly	1
4	9750-021-001	RH Lint Rail Guide Assembly	2
5	9750-022-001	LH Lint Rail Guide Assembly.....	2
6	9046-106-001	Lower Baffle Brace	2
7	9049-131-001	RH Baffle	2
8	9049-132-001	LH Baffle	2
*	9489-060-001	Baffle Reinforcement w/ Thermistor Mount	2
*	9489-059-001	Baffle Reinforcement	6
9	9029-371-001	Angled Baffle Bracket	4
10	9870-102-001	Heat Chamber Assembly.....	2
11	9029-373-001	Heat Chamber Bracket.....	2
12	9444-116-001	Intermediate Panel.....	1
13	9444-115-003	RH Side Panel	1
14	9444-115-004	LH Side Panel	1
15	9636-252-001	Controls Wrapper	1
16	9046-107-001	Top Cabinet Brace.....	1
*	9491-009-001	Rivet-Blind 3/16 Steel	202
*	9491-009-005	Rivet-Blind 3/16 White Painted	52
*	9545-008-024	Screw-10abx3/8	15

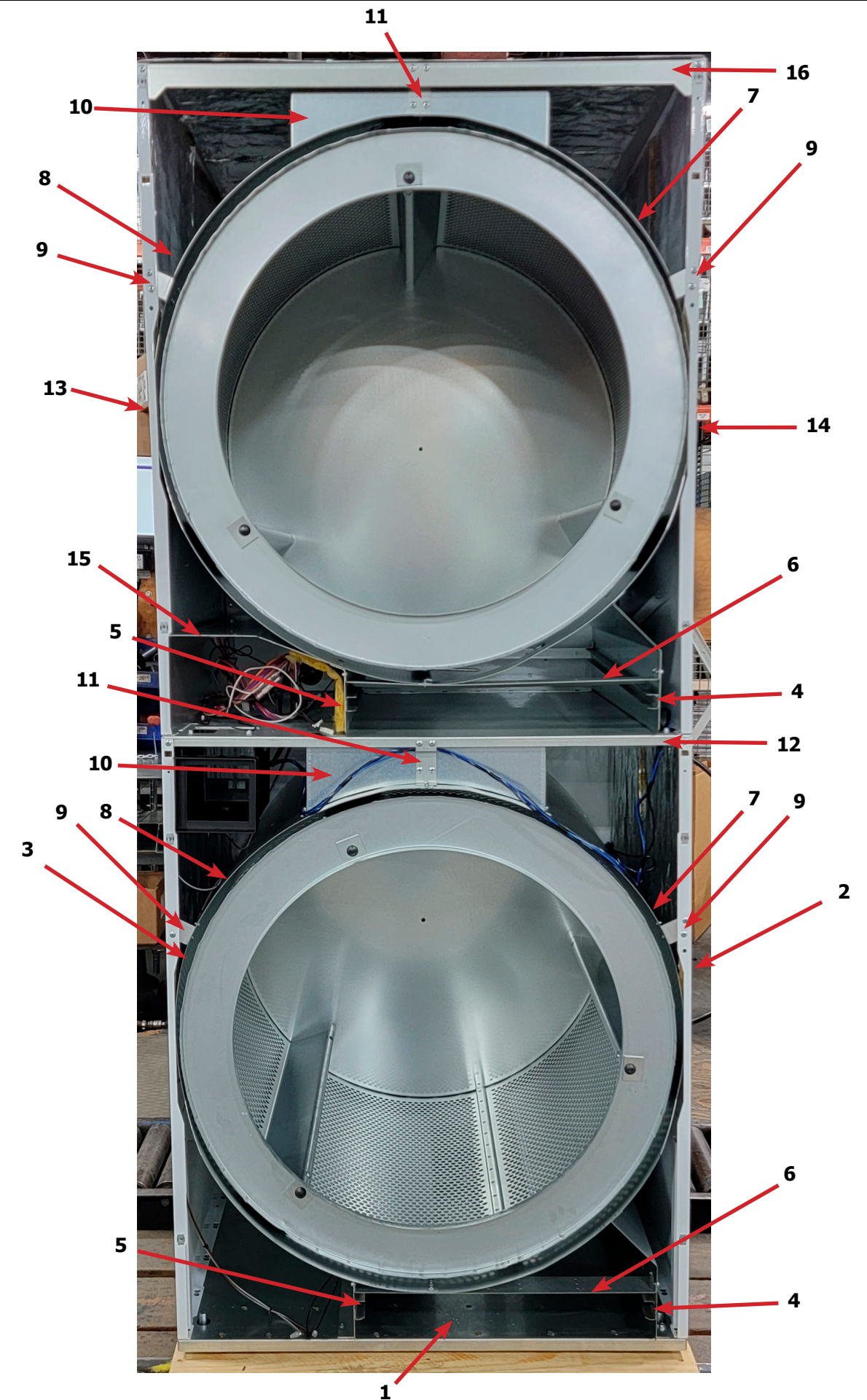

Control Parts Group

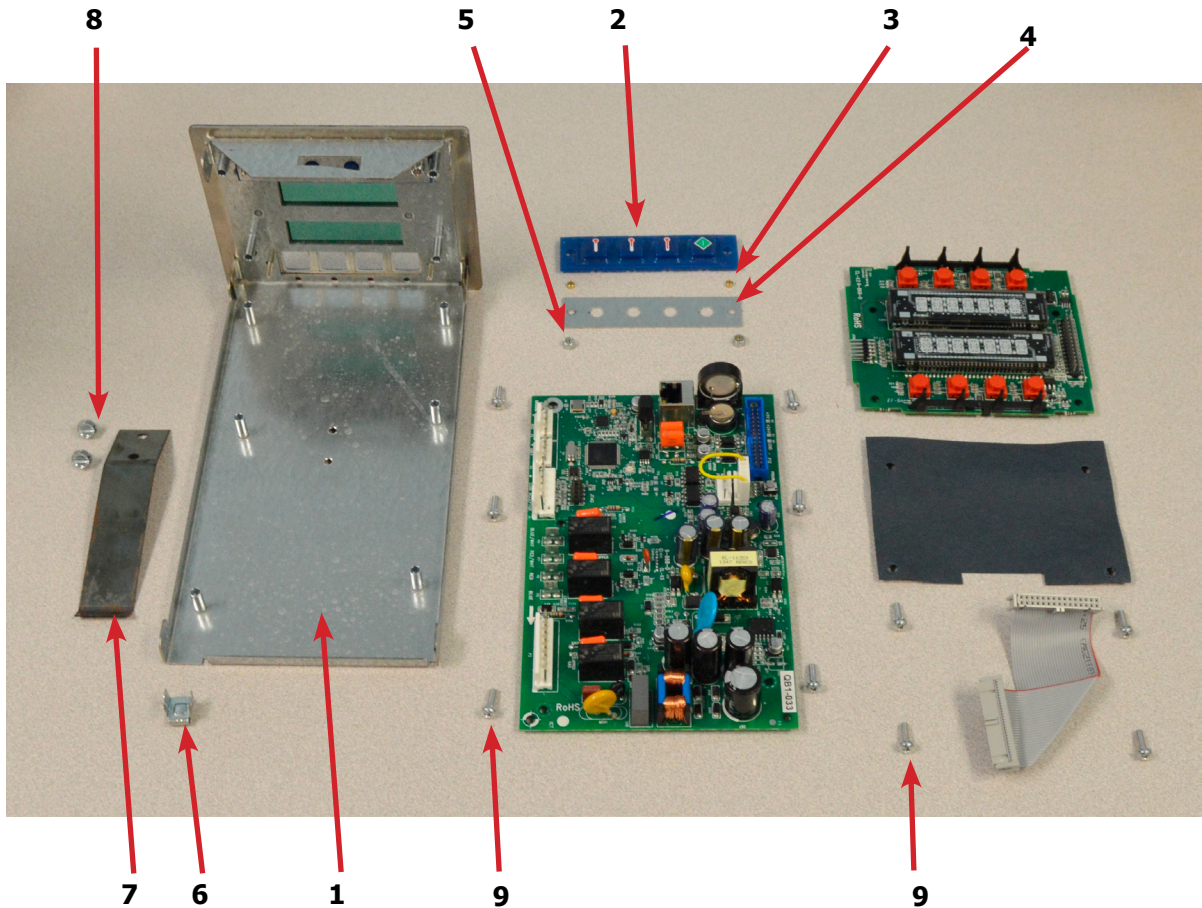

Key	Part Number	Description	Quantity
*	9857-198-002	Controls Assy, 24V, BLU	1
*	9857-198-004	Controls Assy, 24V, BLK	1
1	9826-008-001	Trough Assembly	1
2	9035-062-002	Button-Push, Control, Black	2
2	9035-062-001	Button-Push, Control, Blue.....	2
3	9538-166-011	Spacer-Metal, 4mm	4
4	9486-158-001	Retainer-Push Button	2
5	8640-424-002	Nut-Hex, Elastic stop, #4-40	4
6	8652-130-038	Terminal-Grounding clip	1
7	9534-365-001	Spring-Flat, Control	1
8	9545-008-001	Screw-Hex, #10B x 1/4	2
9	9545-044-010	Screw-Hex, #10B x 1/4	10
9	8641-582-005	Washer-External tooth, #6	10
10	9435-038-001	Overlay-Control, Coin, Black	1
10	9435-038-002	Overlay-Control, Coin, Blue	1
11	9021-041-001	Acceptor-Coin, Optical	1
*	9486-136-001	Retainer, Coin Acceptor	1
12	9545-053-002	Screw	4
*	9801-099-001	Optical Sensor, Replacement.....	1

Note: Jumpers required if using 1.5 Control on Older Machines (P9 Connection)

*	8220-155-001	Wire Assy, Jumper, 30Lb Stack Coin	1
*	8220-155-002	Wire Assy, Jumper, 50Lb Stack Coin	1

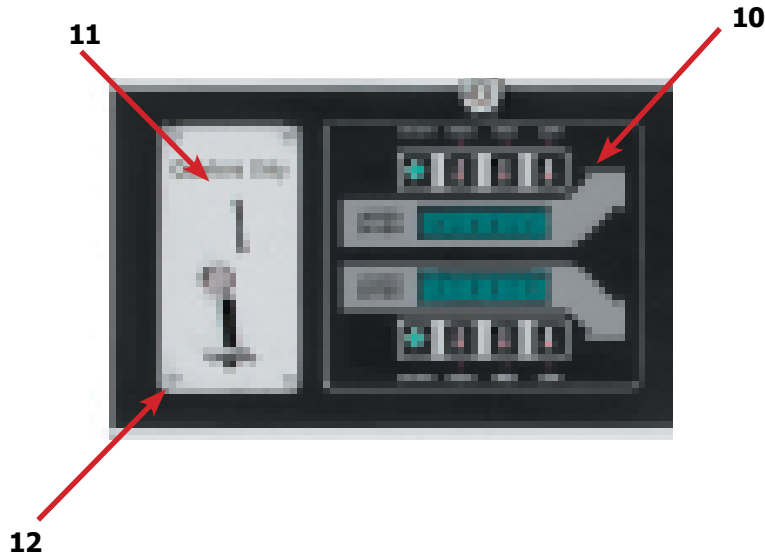

Bearing Housing Group

Key	Part Number	Description	Quantity
*	9803-160-003	Bearing Housing Complete Assy (Includes bearings & Spacer).....	1
1	9241-161-002	Housing, Bearing.....	1
*	9036-130-001	Bearing, Ball, Front	1
*	9538-139-002	Spacer, Bearing	1
2	9036-130-001	Bearing, Ball, Rear	1
3	9545-049-002	Screw-Wizlock, 3/8-24x3/4	4
4	8640-400-002	Nut, 5/16-18.....	4
5	9545-049-001	Screw, 3/8-24x1.....	2
6	8640-415-002	Nut, 3/8-24.....	2
*	9538-139-002	Shim, Tumbler	AR

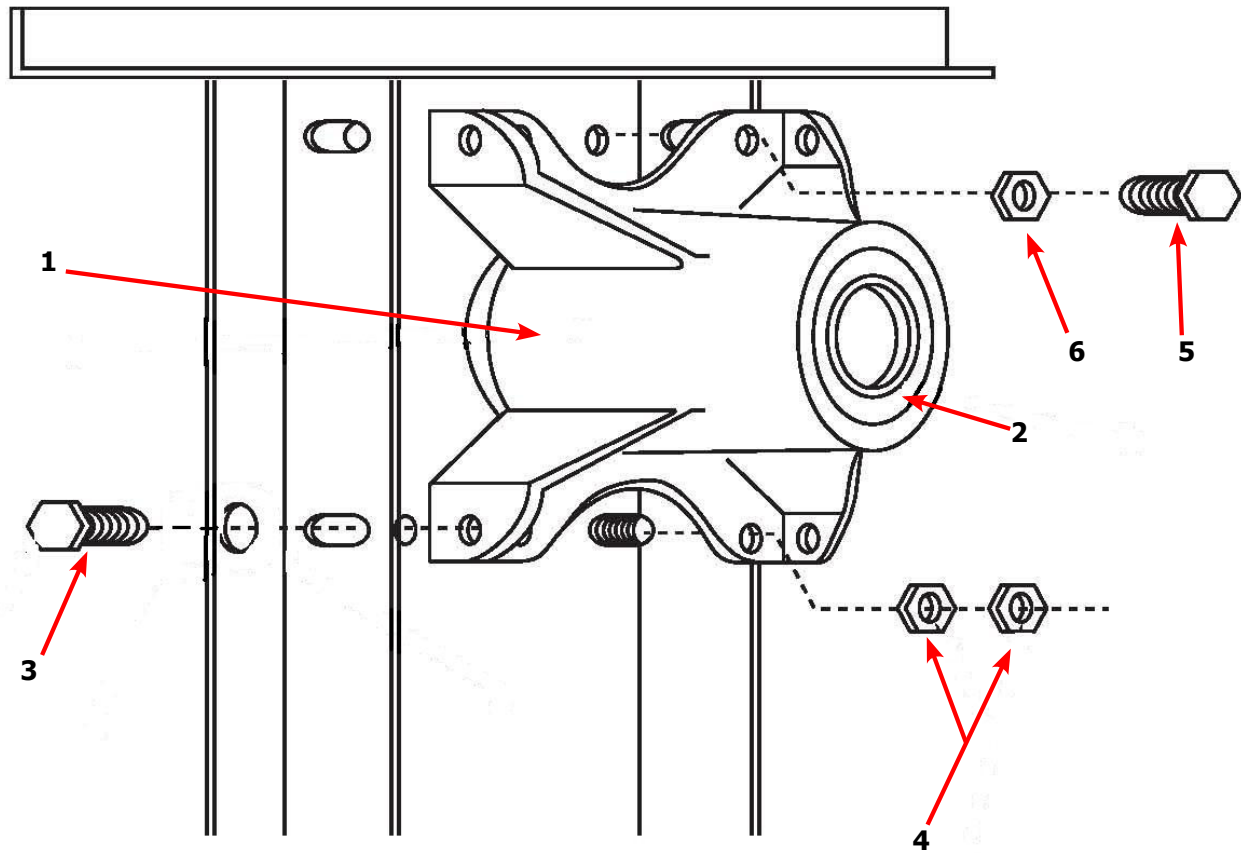

Tumbler Group

Key	Part Number	Description	Quantity
*	9848-147-001	Tumbler Assy Complete W/Spider (GALV).....	1
*	9848-142-002	Tumbler Assy Complete W/Spider (SS & Galv front)	1
1	9848-146-001	Tumbler Assy (Galvanized).....	1
1	9848-146-002	Tumbler Assy (Stainless Galvanized front)	1
2	9497-019-003	Rod, Tumbler	3
3	8641-554-001	Washer, Special.....	3
4	9552-013-003	Shim	AR
5	9568-015-001	Spider Assy.....	1
6	8640-415-004	Nut, Wiz Lock	3
7	9538-164-002	Spacer-Shaft.....	1
8	9487-234-005	Tolerance Ring	1
9	9908-049-002	Pulley, Driven.....	1
10	8641-581-026	Washer -Flat	1
11	8641-582-016	LockWasher - IntTooth, 1"	1
12	9545-017-009	Screw, 1/2-13x1 1/4.....	1

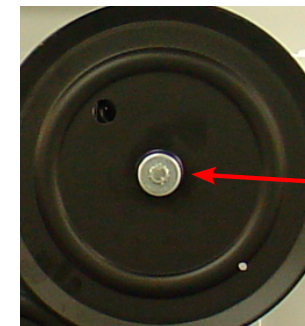
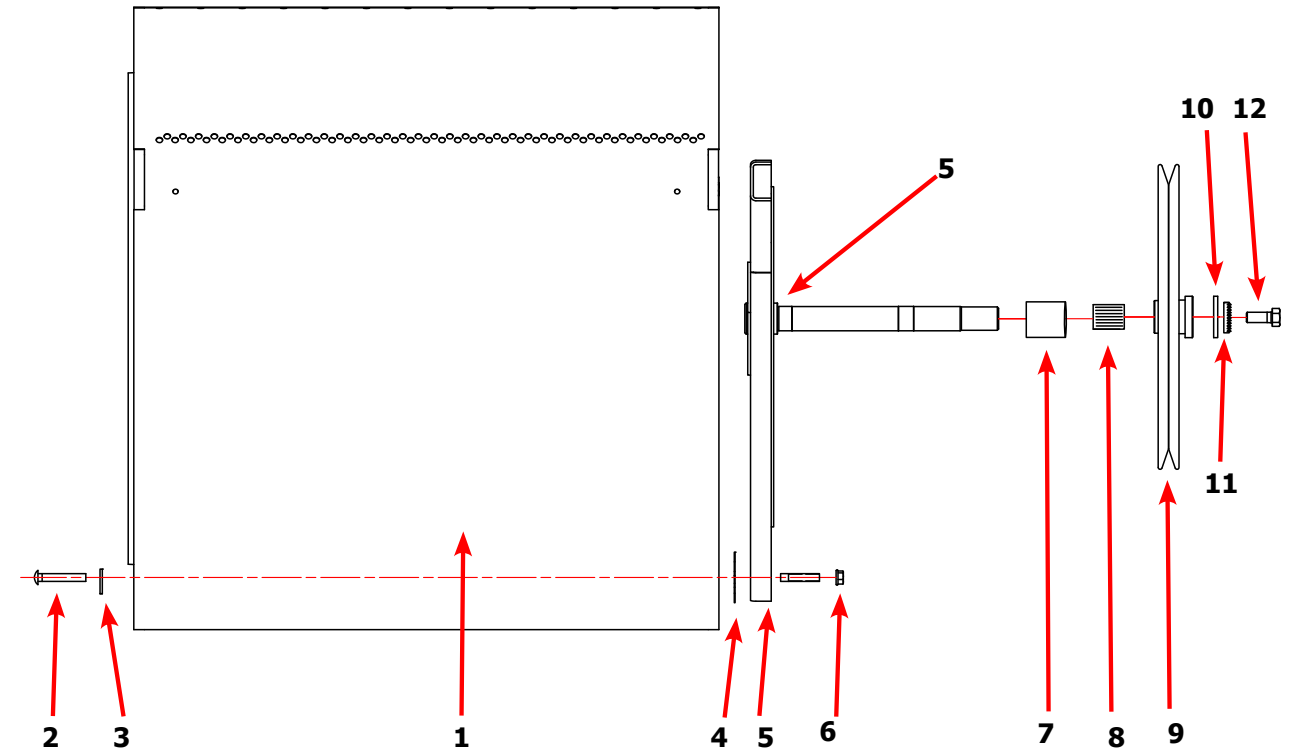

Burner Housing Group

Key	Part Number	Description	Quantity
*	9803-220-001	Housing Assembly, Burner (1 thru 7) (Before Serial D1.19219.026)	2
*	9803-229-001	Housing Assembly, Burner (4a,7a,8a,11,14-20,22) (After Serial D1.19219.026)	2
1	9454-831-001	Panel-Burner Front & Bottom	2
2	9454-826-001	Panel-Burner, Side LH	2
3	9454-790-001	Panel-Burner, Side RH	2
4	9049-080-001	Baffle-Burner (Before Serial D1.19219.026)	2
4a	9049-123-001	Baffle-Burner (After Serial D1.19219.026)	1
5	9454-791-001	Panel-Burner, Top	2
6	9074-307-001	Cover-Burner, Top	2
7	9828-015-001	Connector Assembly-Burner (Before Serial D1.19219.026)	2
*	9545-008-001	Screws-#10B X 1/4	8
*	9545-008-006	Screws-#10AB x 3/8	46
7a	9070-046-001	Connector, Burner (After Serial D1.19219.026)	1
*	9545-008-024	Screw-#10ABx3/8	44
8	9452-729-001	Service Plate, Baffle (Before Serial D1.19219.026)	2
8a	9452-850-001	Service Plate, Baffle (After Serial D1.19219.026)	1
*	9636-241-001	Wrapper, Burner Housing - Inside (After Serial D1.19219.026)	1
*	9636-242-001	Wrapper, Burner Housing - Outside (After Serial D1.19219.026)	1
*	9454-991-001	Panel-Burner, Back (After Serial D1.19219.026)	1
9	9545-008-001	Screw-#10B X 1/4	16
10	9003-220-001	Angle, Burner Support	2
11	9048-020-001	Burner, Main	2
*	9545-008-001	Screw 10B x1/4"	8
12	9452-991-001	Service Burner Plate Front (New style)	2
13	9545-008-001	Screw 10B x1/4"	8
14	9029-192-001	Bracket-High Limit	1
*	9538-142-001	Spacer, Hi-Limit	2
*	9545-045-007	Screw 8B x 3/4"	2
15	9576-203-002	Thermostat, Hi-Limit	1
16	9074-336-001	Cover, Hi-Limit Stat (Before Serial D1.19219.026)	2
16a	9074-329-001	Cover, Hi-Limit (After Serial D1.19219.026)	1
17	9875-002-003	Electrode Assy, Ignition	1
*	9545-045-001	Screw, Electrode Mtg 8B x 1/4"	2
18	9857-134-001	Control Assy, Gas, Honeywell	2
18a	9857-192-001	Control Assy, Gas,White Rodgers (After Serial D1.19217.025)	2
19	9381-012-001	Manifold, Assy	1
*	9425-069-023	Orifice, Burner-Natural #125	2
*	9425-069-024	Orifice, Burner-LP #49	4
20	9029-175-001	Bracket, Manifold	2
21	8615-104-038	Pipe Plug in end of Burner Manifold	2
22	9576-207-008	Thermostat, Safety Shutoff	1
*	9545-008-006	Screw	4
*	8665-073-045	Nipple 1/2" x 2 Black (Before Serial D1.19219.026)	2
*	8655-073-041	Nipple 1/2" Black (After Serial D1.19219.026)	1
23	9825-061-001	Cover, Safety Stat	2
*	9732-102-011	Kit, LP Conversion Honeywell Kit	2
*	9732-102-044	Kit, LP Conversion White Rogers Kit	2
24	9838-018-001	Welded One Piece Gas Pipe Assembly	1
*	9732-360-002	Gas Pipe Assembly Replacement Kit	1
24	9838-023-002	Gas Pipe Assembly (After Serial)	1
*	8615-120-001	Fitting - 1/2 NPT Union Adapter	1
25	9379-196-001	Valve, Gas Shut Off (Optional)	1
26	9452-730-001	Burner tube service plate (Old Style Burner)	2

Burner Housing Group Photos

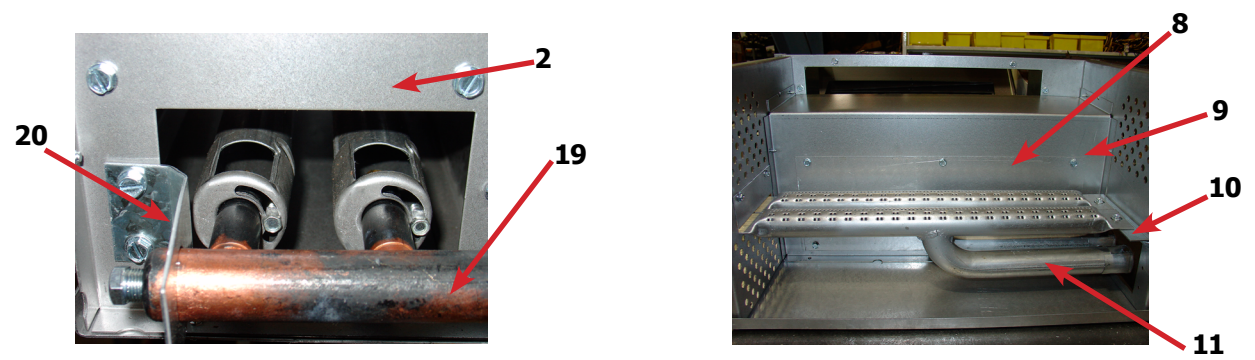
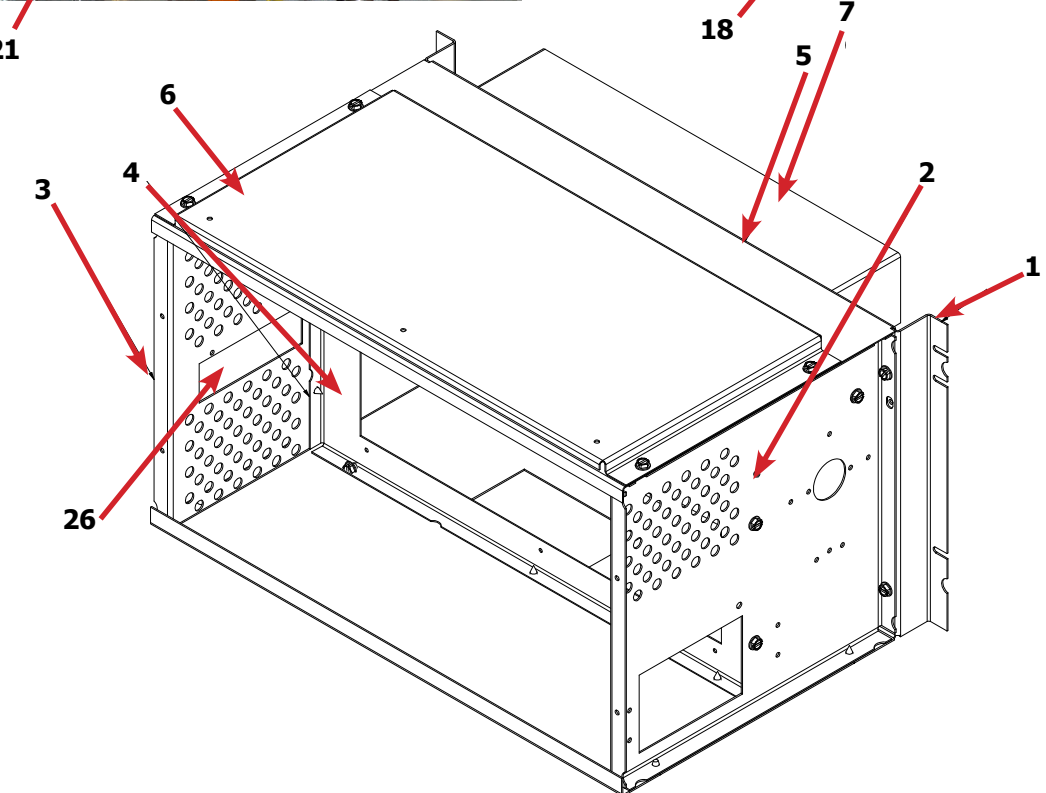
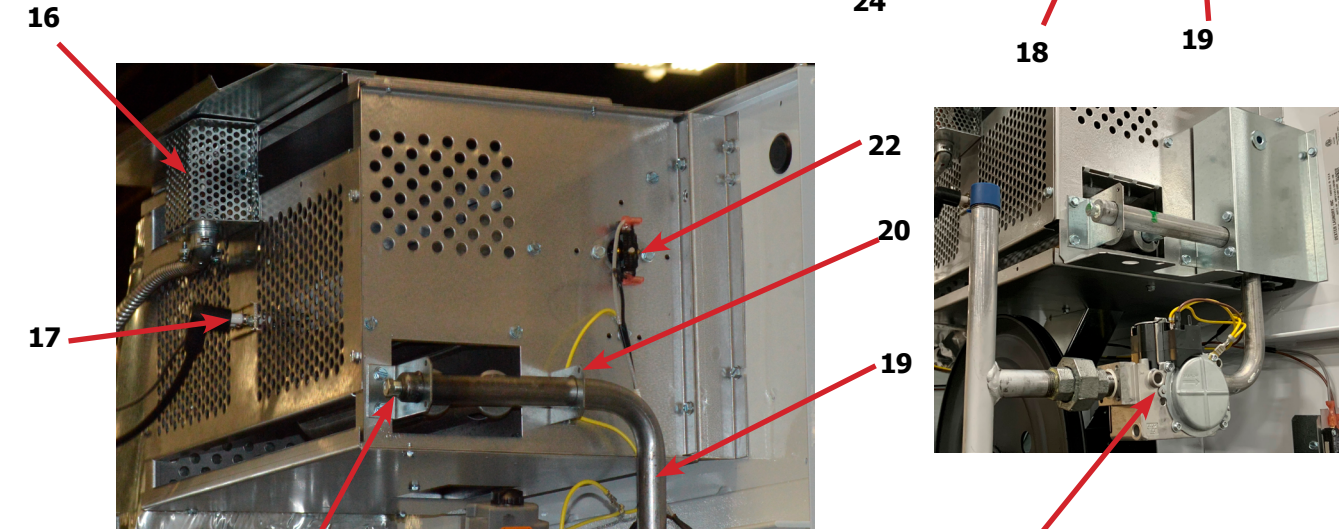
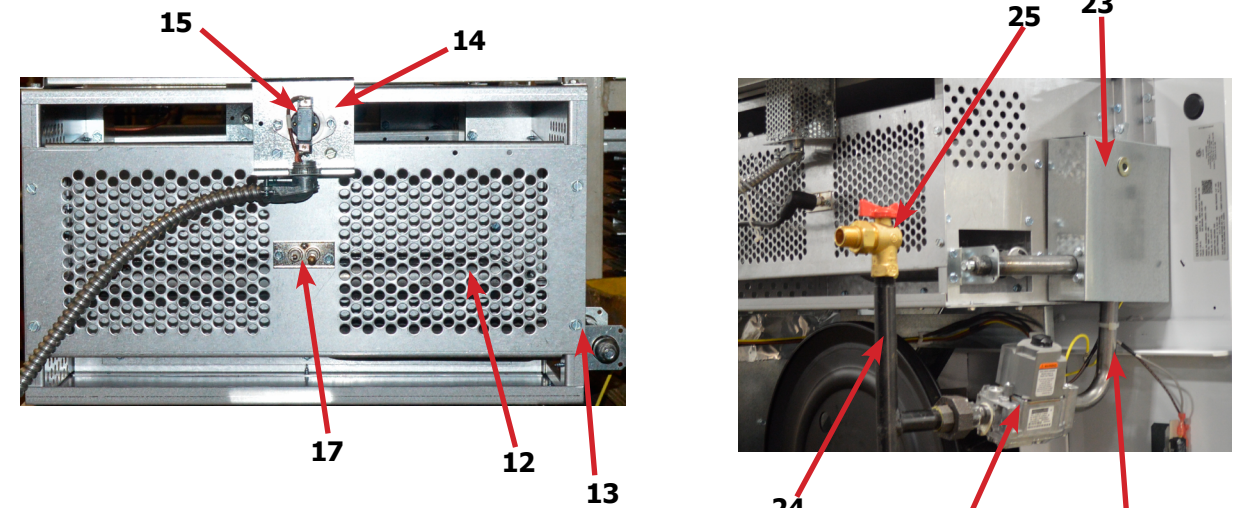

Rear View

Key	Part Number	Description	Quantity
*	9627-861-001	Wire Harness Overtemperature Switch	2
*	9801-095-001	Switch Assy, Air Flow	2
1	9539-461-009	Switch, Air Flow	2
2	9029-174-001	Bracket, Switch- Air Flow	2
3	9008-007-001	Actuator, Switch.....	2
4	9451-169-002	Pin, Cotter.....	2
5	9545-020-001	Screw 4-40 x 5/8".....	4
*	8640-401-001	Nut, Special Twin .#4-40	2
*	9550-169-003	Shield, Switch.....	2
*	9545-008-001	Screw 10 Bx 1/4".....	6
*	9732-205-026	Motor Kit, Blower back, Belt	2
7	9376-331-001	Motor, Drive (Marathon)	2
*	5191-108-002	Run Capacitor, Motor.....	1
*	5191-109-002	Start Capacitor, Motor.....	1
8	9452-740-001	Plate, Motor Mtg.....	2
*	9545-029-008	Bolt 3/8" - 16 x 3/4".....	8
*	8641-582-003	Lockwash Spring 3/8.....	8
9	9545-018-019	Screw, Motor Plate to Back Assy. 1/4-20x 2 1/2.....	8
9	86411-582-007	Lockwasher 1/4	8
9	9538-163-006	Spacer	8
9	8641-581-017	Flat Washer 1/4 x 7/8.....	8
9	9209-086-002	Rubber Grommet	8
*	9538-166-006	Grommet Spacers.....	8
27	9453-157-001	Pulley, Motor	2
*	9545-028-013	Screw, Set.....	4
10	9962-017-002	Back Assy, Blower Hsg	2
26	9278-040-001	Impeller, W/Set Screws	2
11	9991-053-001	Support Assy, Intermed. Pulley.....	2
12	9545-029-010	Bolt, Rd Hd 3/8-16 x 1 1/4	6
13	9545-029-003	Bolt, 3/8-16 x 1 1/2	2
12	8640-415-004	Nut Flange Wizioc 3/8" - 16.....	6
12	8641-581-035	Washer, Flat	6
14	9861-022-001	Arm Assy-Tension, Complete.....	2
*	8641-581-035	Washer, Flat	2
15	9487-200-003	Ring-Retaining.....	6
16	9908-039-004	Pulley Assy, Intermediate with bronze flange bearing.....	2
*	9036-145-002	Bearing - Bronze Flange	4
*	9538-164-002	Spacer-Shaft (See Tumbler Group for Expandr View)	1
*	9487-234-005	Tolerance Ring.....	1
17	9908-049-002	Pulley, Driven	1
18	8641-581-026	Washer -Flat.....	1
18	8641-582-016	LockWasher - IntTooth, 1".....	1
18	9545-017-009	Screw, 1/2-13x1 1/4	1
19	9040-077-001	Belt, Drive- Motor	2
20	9040-073-009	Belt, Drive- Tumbler	2
21	9534-319-002	Spring, Tension.....	2
22	9099-012-002	Chain, Tension	2
23	9248-022-002	Hook, Tension	2
*	9125-005-001	Damper Inside Duct Exhaust	2
24	9451-146-001	Pin, Damper Hinge	2
*	8520-141-000	Nut, Spring.....	4
*	9545-008-026	Screw #10B x 1/2	6
25	9825-059-001	Cover Duct Upper	1
*	9074-314-001	Cover Duct Lower	1
*	9545-008-024	Screw 10ABx 3/8".....	80
25	9973-030-001	Heat Recirculation Assembly Duct	2

Rear View Photos

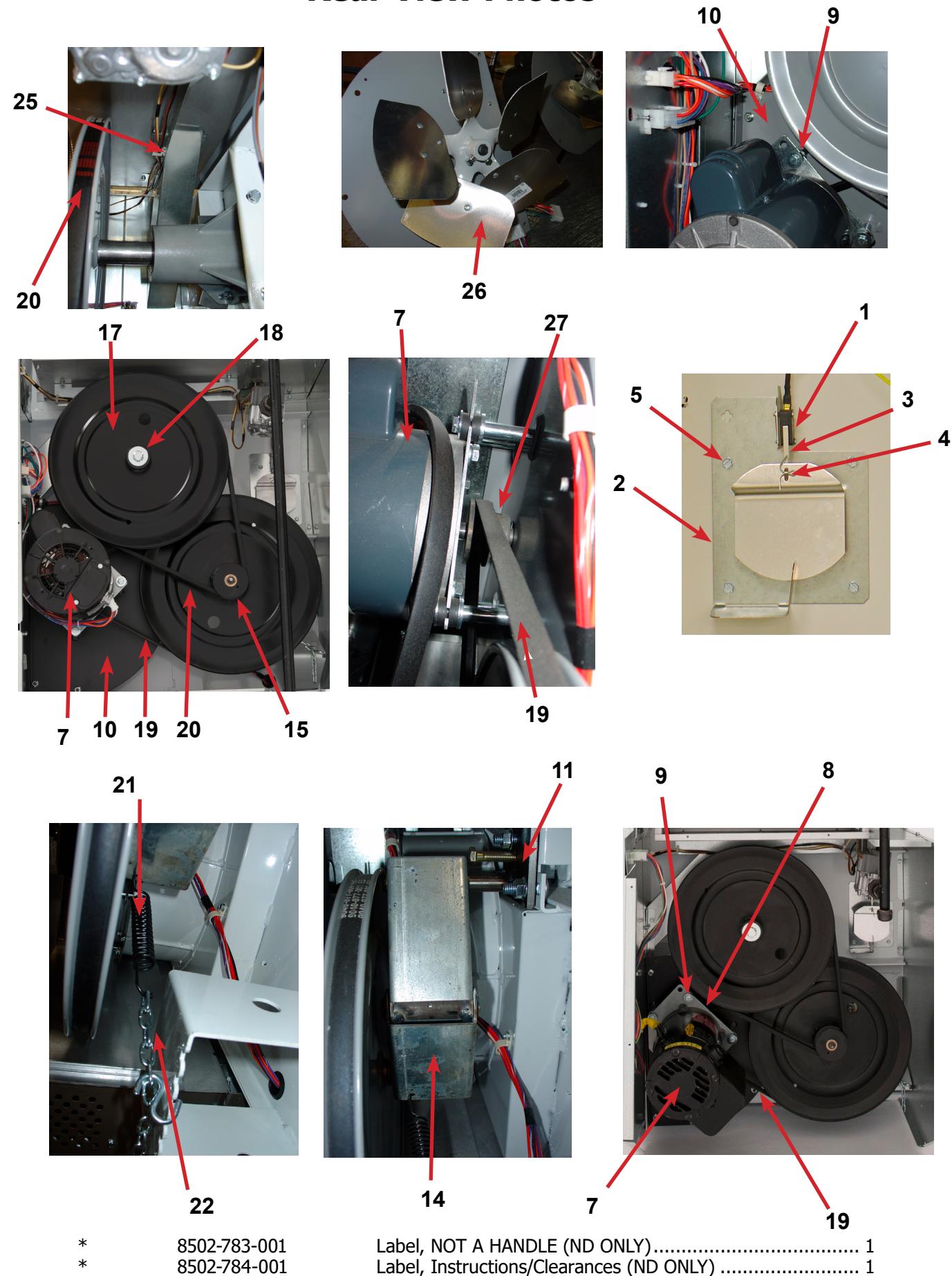

Rear Panel & Cover Group

Key	Part Number	Description	Quantity
1	9208-124-001	Back Drive Guard Panel.....	2
2	9208-123-001	Back Side Guard Panel (Before Serial D1.19219.026).....	2
*	9208-073-001	Guard, Small Lower (Before Serial D1.19219.026).....	1
*	9208-074-001	Guard, Small Upper (Before Serial D1.19219.026).....	2
*	9545-008-024	Screw, Guards.....	28
*	9074-365-001	Cabinet (TOP COVER).....	1
*	8544-006-001	Legs Leveling.....	4
4	9108-117-001	Electric Box Cover.....	6
5	9545-008-024	Screws 10 AB x 3/8.....	4
6	9109-113-001	Top Duct w/ Round.....	1
7	9074-364-001	Lower Duct Cover.....	1
*	9545-008-024	Screws 10AB x 3/8.....	14
*	9973-034-001	8" Slide Open Clean Out Duct (Optional).....	1
8	9550-173-001	Burner Inlet Shield.....	1
*	9545-008-024	Screws 10AB x 3/8.....	3
*	9208-154-001	Back Side Guard Panel (After Serial D1.19219.026).....	2

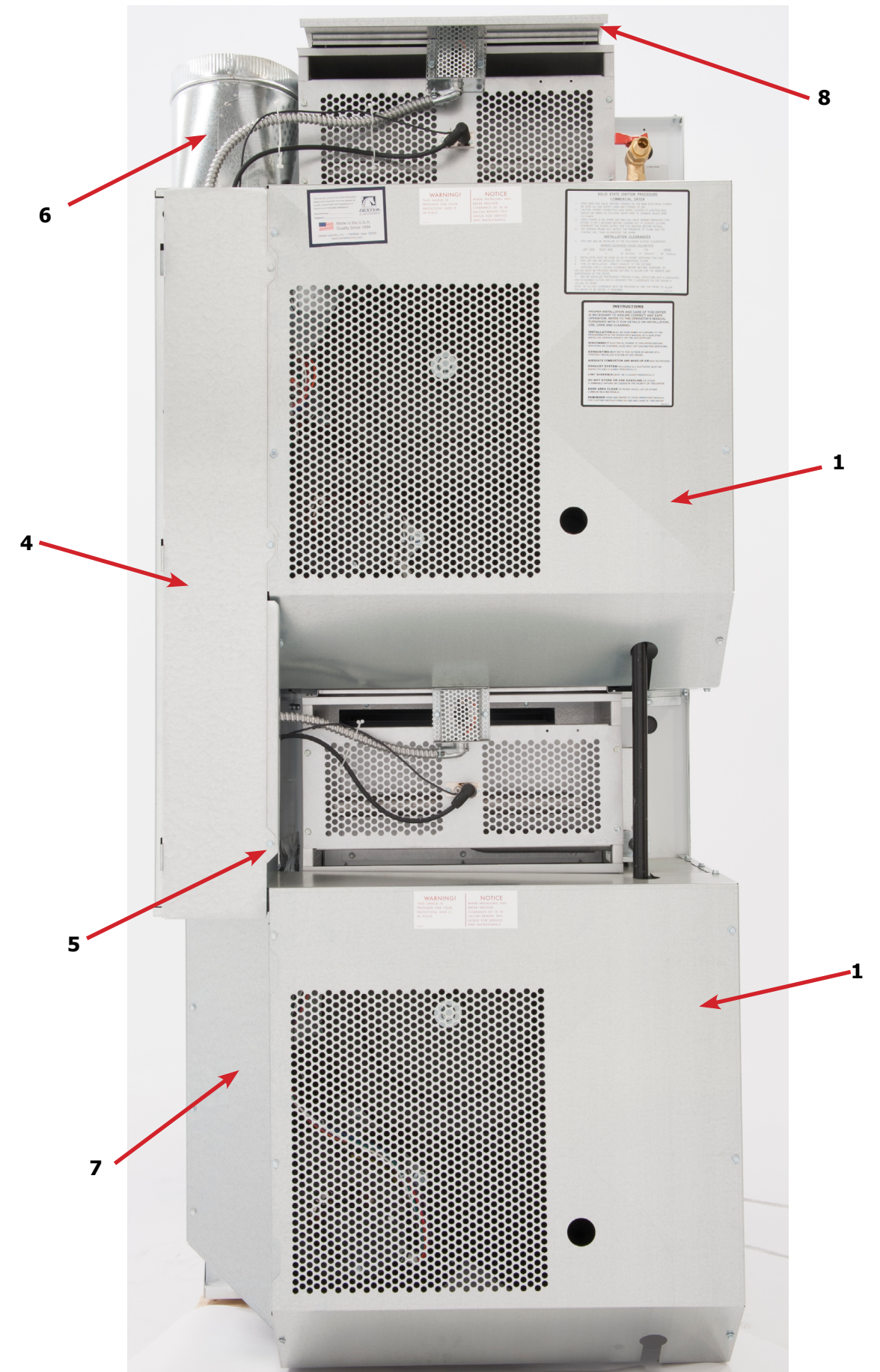

Control Assembly Group

Key	Part Number	Description	Quantity
*	9857-169-011	Control Assmly Complete (all below included)	1
*	9074-317-001	Control Box Cover	1
1	8653-068-003	Connector Conduit 3/8" STR.....	1
2	9558-031-001	Strip Terminal Marker (Behind Input Power) to above #3.....	1
3	9897-035-001	Terminal Block Assembly Main Power Inlet	1
*	9545-008-024	Screws 10AB x 3/8"	4
*	9627-859-003	Wire Harness - Power Main	1
4	8220-001-478	Wire Assembly Green 7"	1
5	9545-008-027	Screw # 10-32 x 12 Green	1
*	8641-582-006	Lockwasher Ext Tooth #10.....	1
6	9897-026-002	Terminal Block Main Power Middle	1
7	9897-026-001	Terminal Block.....	2
*	9545-045-012	Screw #8 ABx1 2 for terminal block.....	6
8	8711-013-001	Transformer Control.....	1
*	9545-008-024	Screws 10AB x 3/8"	4
9	9857-182-001	Ignition Control	2
*	9545-008-018	Screws 10AB x 3/4"	4
10	9631-403-009	Wire Assembly High Voltage Upper.....	1
11	9627-867-005	Wire Harness Ignition Control Upper.....	1
12	9631-403-008	Wire Assembly High Voltage Lower.....	1
13	9627-867-006	Wire Harness Ignition Control Lower.....	1
*	9053-067-002	Bushing Wire 7/8".....	4
14	9200-001-002	Fuseholder Assembly.....	3
*	8636-018-001	Fuse 1.5 Amp.....	2
*	8636-018-004	Fuee 2.5 Amp.....	1
15	5192-299-002	Relay Power	2
*	9545-045-012	Screws Power #8 AB x 1/2".....	4
*	8220-062-036	Wire Assembly Red/Black 14"	1
*	8220-062-037	Wire Assembly Red/White 14"	1
16	9627-864-006	Wire Harness Motor Extension.....	2
17	9527-007-001	Stand Off - Wire Saddle / Arrowhead	5
18	9627-953-003	Wire Harness Main Extension Access Under Burner Housing.....	4
*	9083-124-001	Clip, Cable Edge (w/wiretie) (After Serial D1.19219.026).....	4

Control Protection Fuse **14**
2.5 Amp

1 Ignition Upper Pocket
Protection Fuse 1.5 Amp

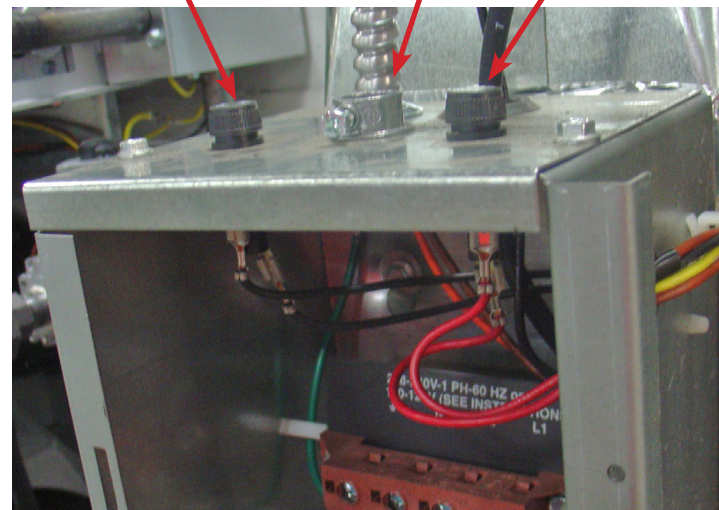

Not Shown:
24VAC Ignition Lower
Pocket Protection
Fuse

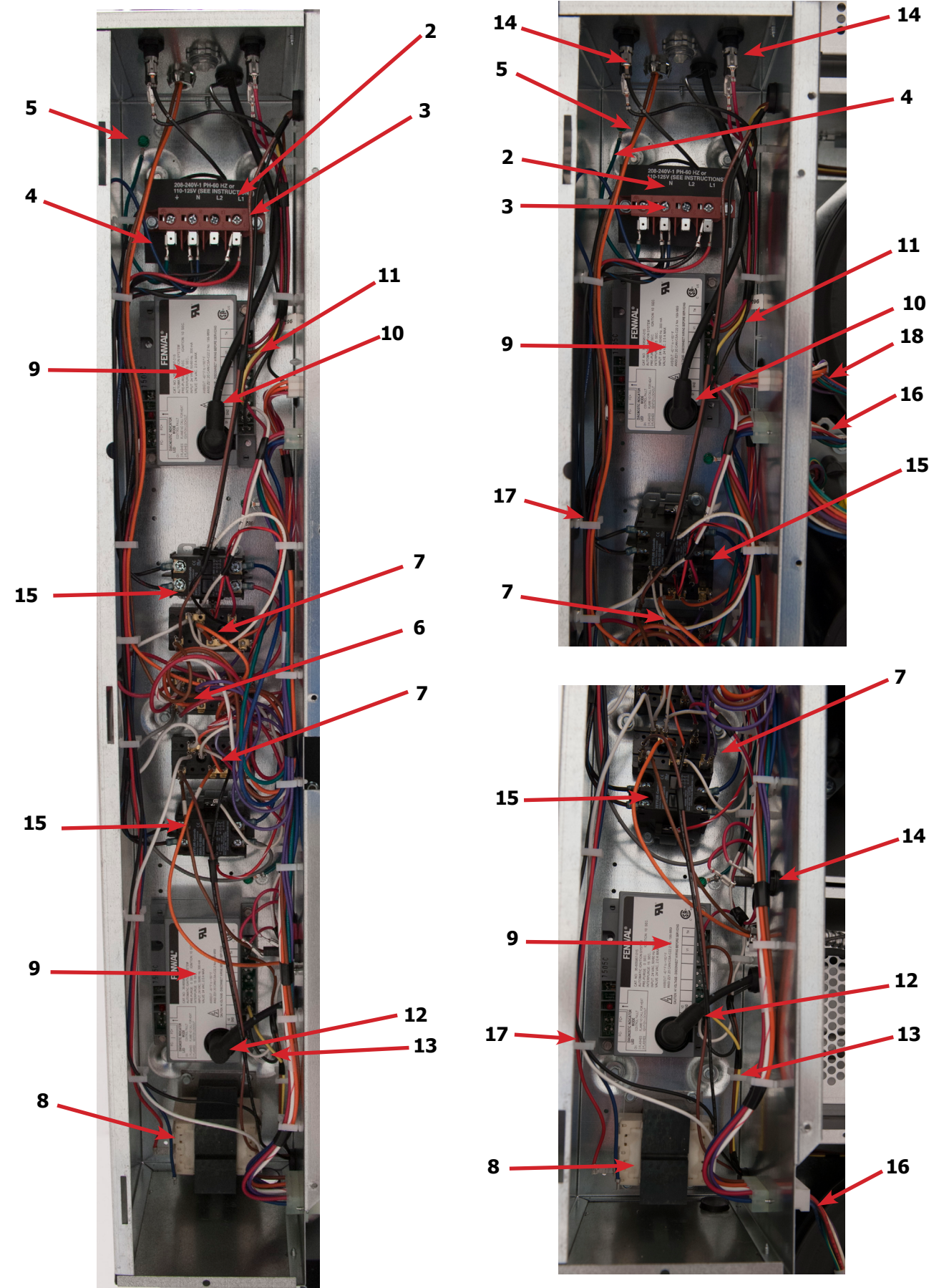

Coin Acceptor

Key	Part Number	Description	Quantity
1	9021-041-001	Coin Acceptor, Optical.....	1
2	9801-099-001	Sensor-Optical, Replacement.....	1
3	9545-039-002	Screw, Height Bar, 3mm.....	2
*	9486-136-001	Retainer, Coin Acceptor	1
*	9545-053-002	Screw	4

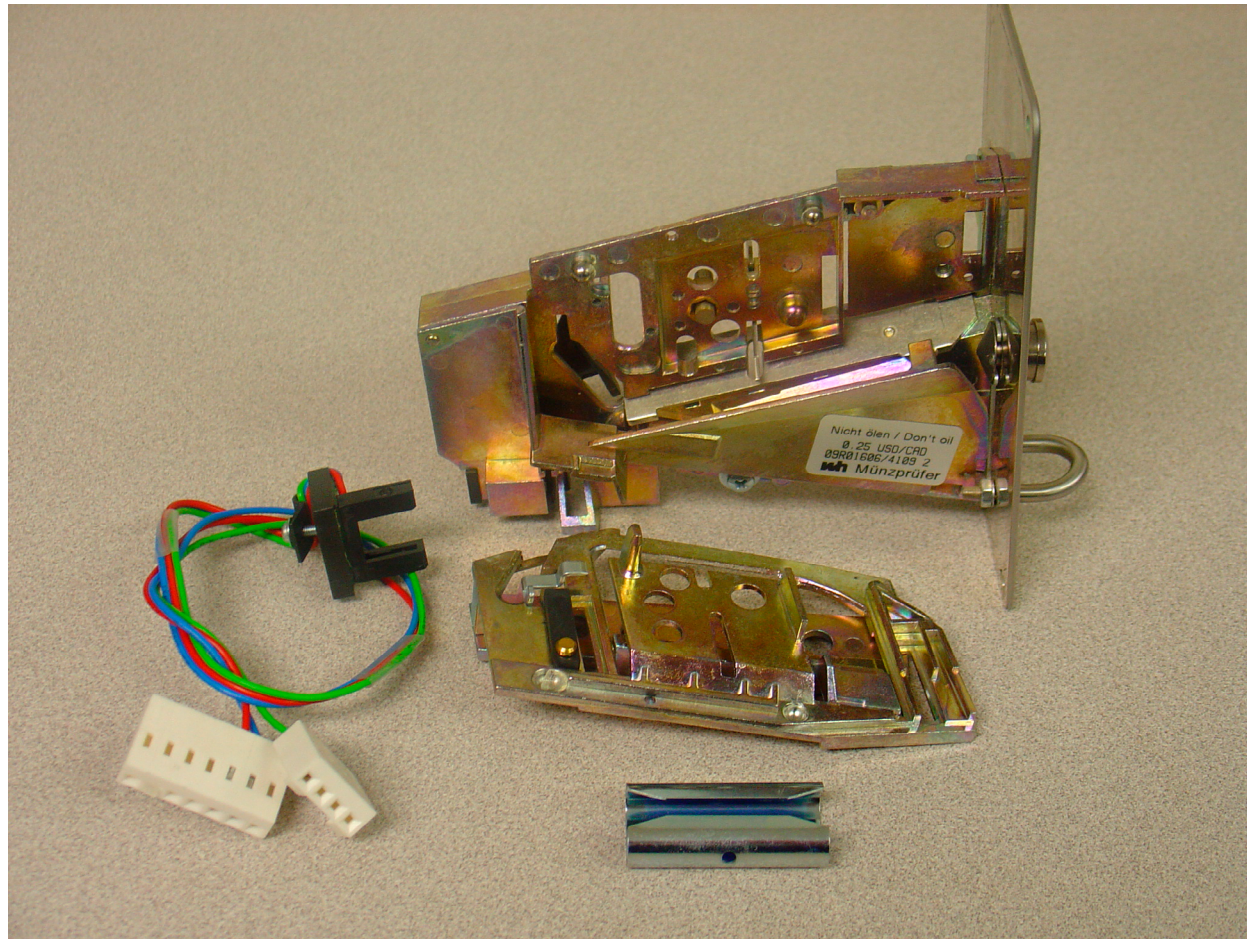

Wiring Group

Key	Part Number	Description	Quantity
*	9627-953-003	Wiring Harness- Main Power	1
*	9631-403-001	Wire, Hi Voltage, Spark 38".....	2
*	8502-645-001	Label Instruction.....	1
*	9506-544-001	Wiring Label Schematic/Diagram	1
*	9627-860-001	Wire Harness Ignition Upper Low Voltage	1
*	9627-860-002	Wire Harness Ignition Lower Low Voltage	1
*	9627-953-003	Wire Harness Main Extension	1
*	9627-864-001	Wire Harness Motor Extension	2
*	8220-062-036	Wire Assembly Red/Black 14".....	1
*	8220-062-037	Wire Assembly Red/White 14".....	1
*	8220-062-038	Wire Assembly White 14".....	2
*	9627-861-001	Wire Harness - Overtemp / Airswitch	2
*	9627-862-001	Wire Harness Main Controller w/ Door Switch Wires	1
*	9627-855-003	Wire Harness - Heat Sensor	1
*	8527-112-001	Decal Lighting and Clearance.....	1
*	8502-763-001	Label Warning & Notice	2
*	8502-764-001	Label Warning Dryer, FRN/SPN	2
*	9506-544-001	Schematic /Diagram.....	1
*	8514-233-001	Operators Manual	1
*	8507-365-001	Instructions Convert Dual Voltage	1
*	8507-330-001	Instruction Transient Voltage Suppressor	1
*	8507-350-001	Instructions Dryer Install / Start	1
*	8220-137-001	Wire Assembly Green 24".....	1
*	8220-001-466	Wire Assembly Yellow 4 7/8" Gas Valve	2
*	8220-095-038	Wire Assembly Orange 48".....	2
*	9506-544-001	Wiring Schematic/Diagram	1
*	8220-095-040	Wire Assembly Orange 24".....	1
*	8220-095-041	Wire Assembly Brown 24".....	1
*	9052-067-002	Bushings Wire 7/8".....	4

Wiring Diagram for DC30x2

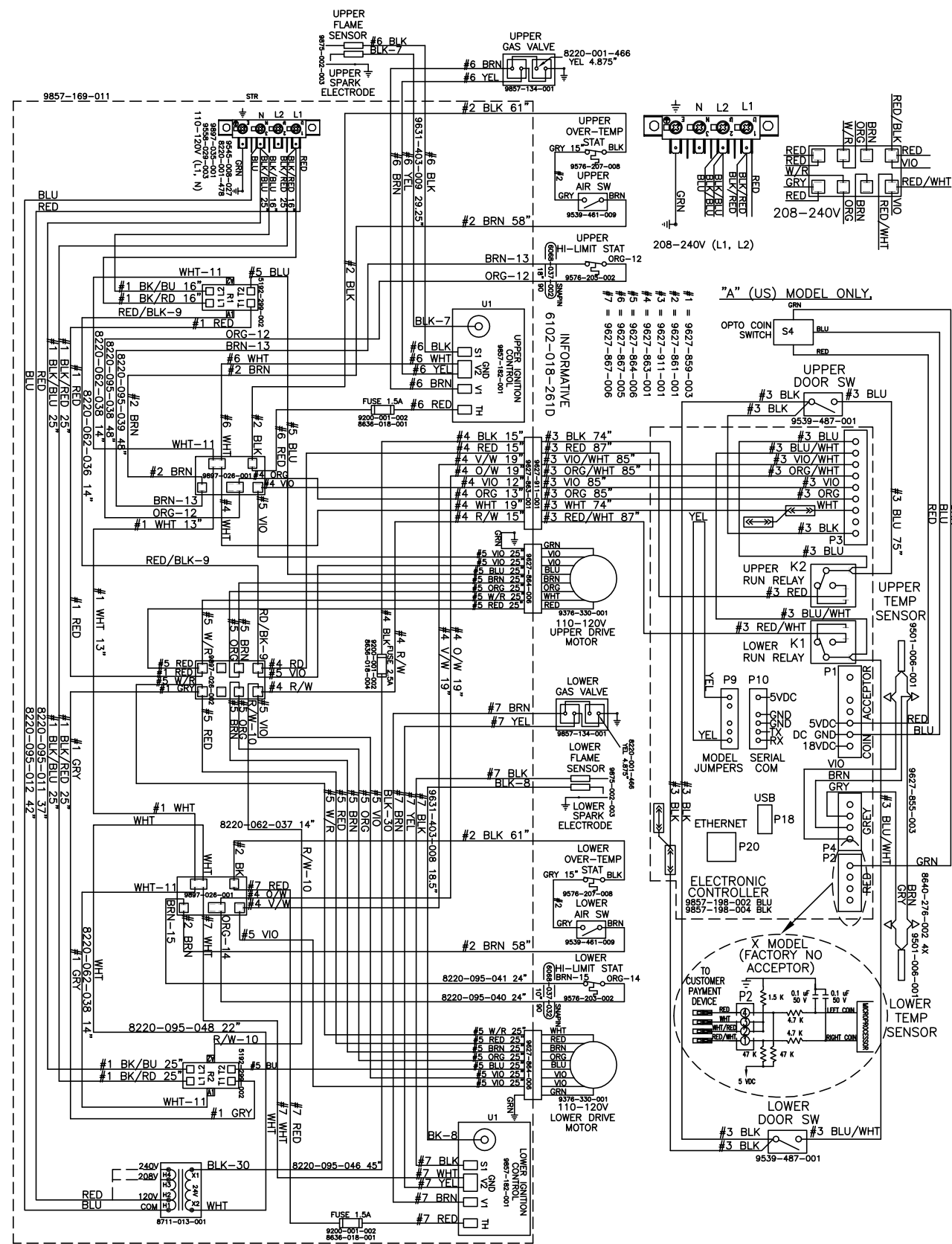

9506-595-001B WIRING DIAGRAM DC30X2NC-15EC2X-

Wiring Schematic for DC30x2

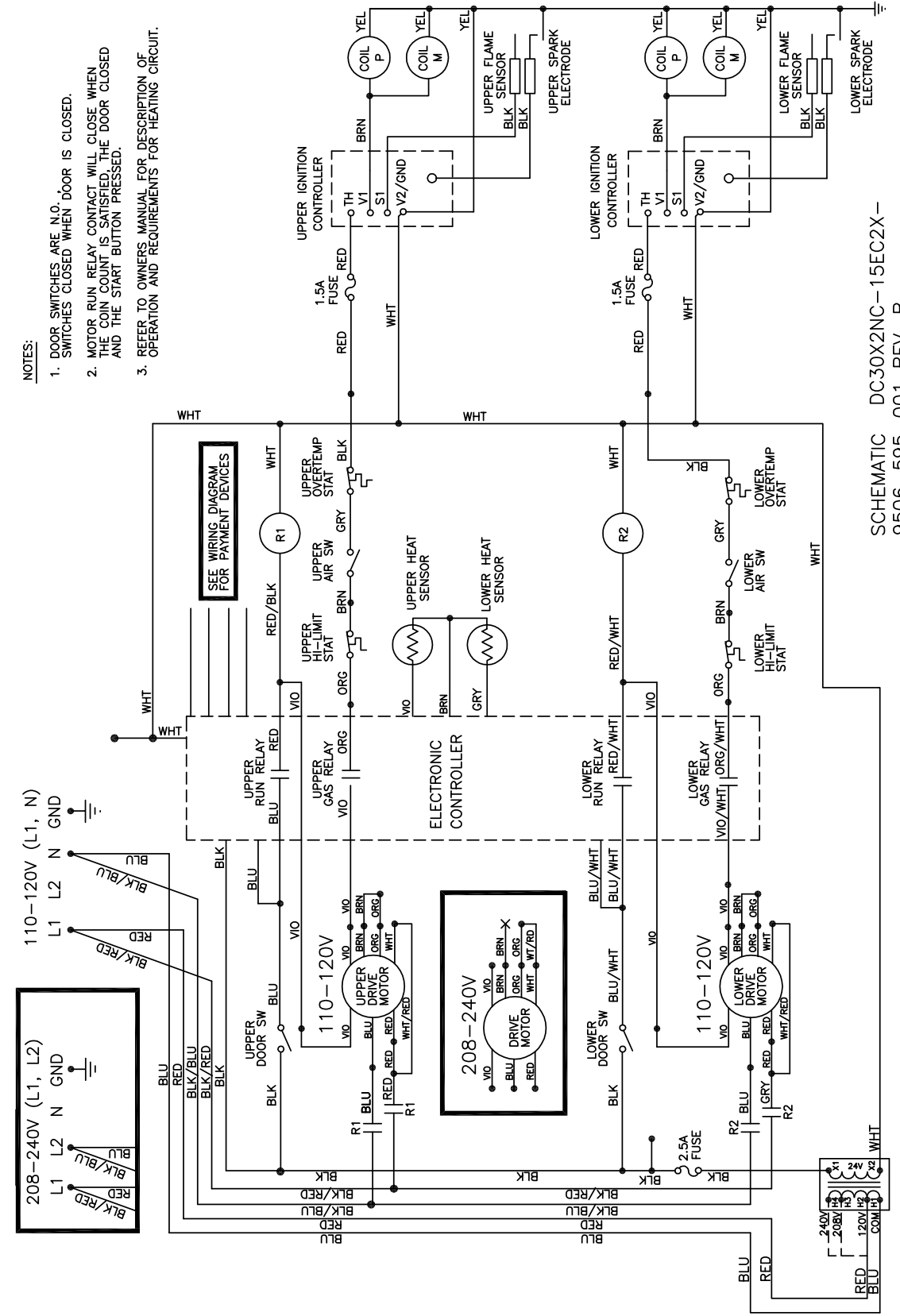

SCHEMATIC DC30X2NC-15EC2X-
9506-595-001 REV. B
110-120/208-240V, 1 PHASE, 60 HZ

IMPORTANT: RETAIN THIS ELECTRICAL SCHEMATIC FOR SERVICE.

**Instructions - Convert a Dual Voltage Stack Dryer from 120V to 208-240V
(No Neutral Required)**

1. Remove incoming power from the dryer. Use a known working voltmeter to check power.
2. Remove the cover of the control box assembly from the dryer using a 5/16" wrench.
3. Move the black/blue wire AND the blue wire from the N position of the main power terminal block to the L2 position of the main power terminal block in the upper control box assembly. See figure below.
4. Move the white/red wire of the upper motor harness to an upper inner left terminal in the middle terminal block in the lower control box assembly. See figure below.
5. Move the orange wire of the upper motor harness to an upper inner left terminal in the middle terminal block in the lower control box assembly. See figure below.
6. Move the white/red wire of the lower motor harness to a lower inner left terminal in the middle terminal block in the lower control box assembly. See figure below.
7. Move the orange wire of the lower motor harness to a lower inner left terminal in the middle terminal block in the lower control box assembly. See figure below.

Conversion instructions continued on next page.

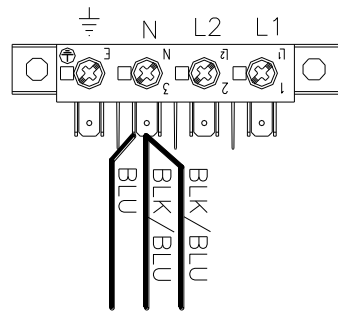

110-120V (L1, N)

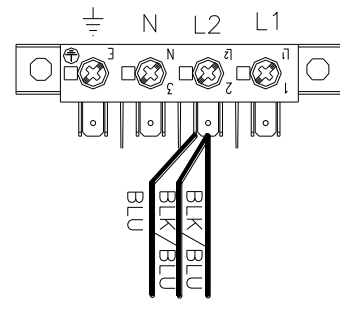

208-240V (L1, L2)

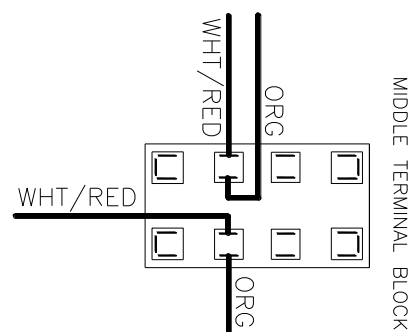
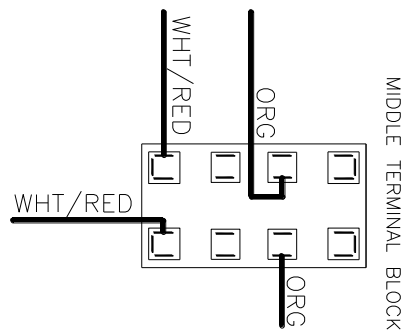

8. Move the red wire from the 120V tap on the transformer found in the bottom of control box to the required voltage tap based on actual supply voltage measurement. See figure below.

CONTROL TRANSFORMER CONNECTIONS
AS VIEWED FROM SIDE OF TRANSFORMER

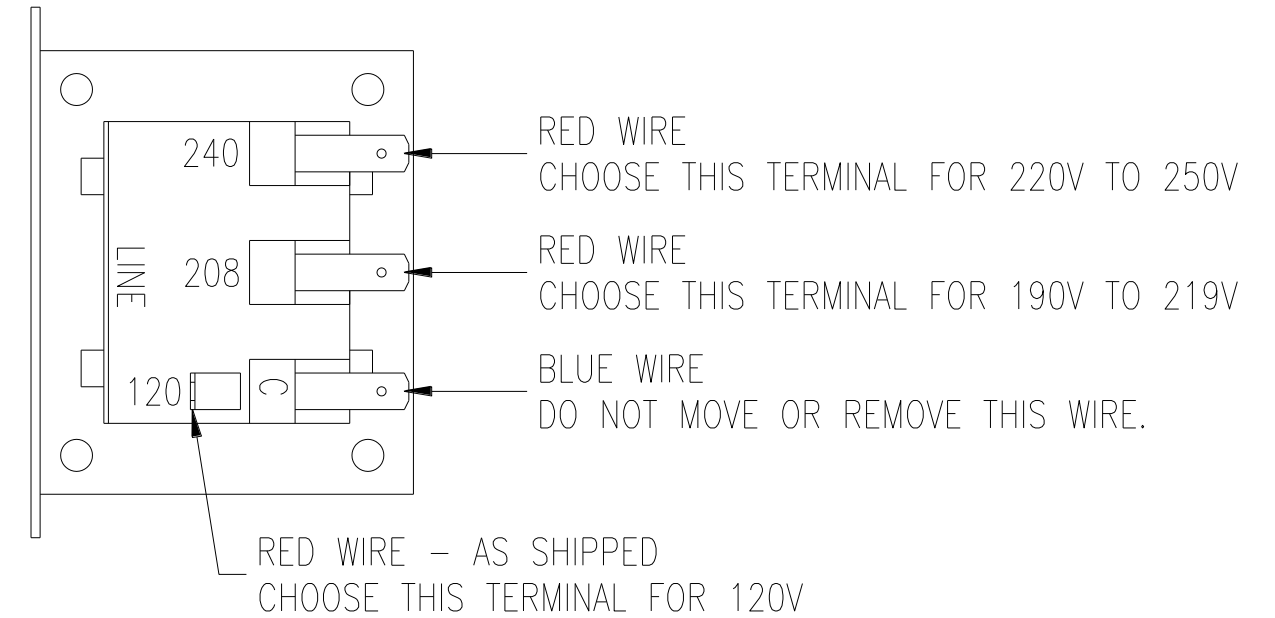

9. Reconnect power to the dryer and test to ensure proper operation; one line voltage to L1, one line voltage to L2 and the earth ground to E.
10. Reinstall the cover of the control box assembly on the dryer using a 5/16" wrench.

Notes

Lined area for notes.

Section 9:
50 hZ
Models

Notes

50 Hz Specifications

Dry Weight Capacity:	13.5kg @ 2 each - 27kg total
Basket Depth:	699mm
Basket Diameter:	762mm
Basket Volume:	318 liters
Door Opening:	576mm
Overall Height (with legs):	min. 1937mm, max.
Cabinet Width:	800mm
Overall Depth:	1270mm
Door Height (floor to bottom of door):	186mm
Cylinder Rotation Direction:	CCW
Speed:	47rpm
Natural Gas Supply (water column):	4" - 10" wc
Natural Gas at Burner Manifold:	3 1/2" wc
LP Supply:	11" - 14" wc
LP Burner:	11" wc
Gas Inlet Line Size:	1/2" npt
Motor Size:	373kw

Electrical

Voltage: 220-240v/ 50hz/ 1 phase	
Running Amps:	10.0
Amp Circuit Protection:	15
Wire Size:	12 guage
Electrical Service:	3 wire + ground

Weights

Shipping:	351kg
Net Weight:	311kg

Clearance behind machine for service minimums:	457mm
--	-------

50HZ Wiring Schematic Dryer Idle - No Coins Added

Top Dryer Used For This Example

230 VAC 50 HZ is supplied to the Main Power Terminal Block and passes through a In-line Noise Filter and comes out on BLK/RED and BLK/BLU wire. 230 VAC now passes to a Multitap Control Step Down Transformer and also passes to the Motor Control Relay (R1&R2). When there is power to the dryer the Computer Board will be powered and the display lighted from the 24 VAC secondary side of Control Step Down Transformer. 24 VAC from here is also on one side of the door switch on a black wire. Closing the loading door allows 24 VAC to pass on to the Computer Board on two blue wires. One blue wire makes 24 VAC available to one side of the Motor Run Relay on Computer Board. The other blue wire provides a 24 VAC signal to the Computer Board telling it that the door is closed and door light on the computer board should be illuminated.

Coins Added - Motor Starting and Running

Top Dryer Used For This Example

As each coin is added the Coin Switch closes and completes a circuit to the Computer Board. The Computer Board counts these signals and registers them against time. The time will display once the Start Button for Upper or Lower is pushed. When the Start Button is pushed again the Computer Board Motor Run Relay closes on the computer. With this Relay closed, 24 VAC is supplied to the Motor Control Relay (R1) on the red wire and also a violet wire going down to motor. The motor LED on the computer board should be illuminated anytime the computer calls for the motor to operate. With (R1) engaged and 230 VAC at motor the Motor Start Switch in motor is drawn in to the start position. In this position the incoming power 230 VAC is supplied directly to the main run winding and through the Start Capacitor to the Auxiliary Winding (start winding). As the Motor comes up to speed, the centrifical switch inside motor opens the circuit to the Start Winding and closes the circuit to allow 24 VAC to pass to the Gas Relay on the Computer Board on the other violet wire. The heat circuit in the dryer can not operate if the motor is not running. The gas LED on the computer board will be illuminated when Computer Board calls for the heat after Motor Centrifical Switch has closed.

Heat Circuit

Top Dryer Used For This Example

With the Drive Motor running and 24 VAC provided to the Computer Board Gas Relay, it will close if Computer Board senses programmed temperature is needed. The violet wire changes to an orange wire out of the Computer Board Gas Relay. When this relay closes it provides 24 VAC to the High Limit Thermostat. The High Limit Thermostat is normally closed. (It will open, turning off the heat circuit, if the dryer can't move enough air from problems such as an exhaust restriction or other problems.) 24 VAC now goes through to the normally open Air Switch (Sail Switch) on the brown wire. This switch is closed only if the dryer is running and has the correct air flow. With the dryer running and the Air Switch closed, 24 VAC is supplied to the normally closed upper manual reset Overtemp Thermostat on the gray wire and changes to the black wire out of switch and then changes to red wire and goes to the 1.5 amp in-line fuse that protects the Upper Ignition Controller (GREY BOX). With 24 VAC now supplied to the Upper Ignition Controller (GREY BOX) it will then send high voltage to the Spark Ignition Electrode via the High Voltage Lead Wire (this lead looks like an automotive spark plug wire). The Ignition Control Module (GREY BOX) simultaneously sends 24VAC to the Gas Valve Coil which open the Gas Valve and allows gas to pass through to the main burner. When ignition occurs the high voltage sparking stops and if Ignition Control Module (GREY BOX) gets a flame sense signal it will allow gas valve coil to remain energized and continue burner operation. If ignition does not occur, the Ignition Control Module (GREY BOX) will spark for 10 seconds before locking out.

Manual Reset Safety Shutoff Over-Temperature Thermostat

Top Dryer Used For This Example

This thermostat is manually reset by pushing in the red button. The Over Temperature Thermostat is a safety backup for the entire Heat Circuit and located in the recirculation chamber area on the side of the burner housing. If the dryer over heats this Over Temperature Thermostat it opens the line to turn off the heat but leaves the Computer Board lighted and the drive motor powered and turning so the basket will cool down.

Cool Down

Top Dryer Used For This Example

At the preprogrammed time (2 minutes factory setting--adjustable) the Computer Board will open the Gas Relay Contact. This allows the Drive Motor to continue to run but without heat. The gas light on the computer board should not be illuminated anytime the computer is in cool down. This Cool Down period allows the clothing (zippers, snaps, etc.) time to cool down to a temperature that is easily handled by customers.

End of Cycle

Top Dryer Used For This Example

At the end of the cool down, the Computer Board opens the Upper Run Relay, which removes power from the Motor Control Relay (R1) and also removes power to the Drive Motor. The motor light on the computer board should no longer be illuminated. The Drive Motor and tumbler stops and the Computer Board display now flashes until the dryer loading door is opened. Once the dryer loading door is opened to remove the clothing the display goes back to vend price.

-39 & -59 Models 50 Hz Parts

Key	Part Number	Description	Quantity
*	9558-029-004	Strip, Terminal Marker -39 Models	1
*	9558-033-001	Strip, Terminal Marker -59 Models	1
*	9183-030-002	Filter EMI -59 Models	1
1	8711-008-002	Transformer	1
1	8711-004-004	Transformer (-59 Models after Serial #)	1
*	8507-230-003	Instructions, Transformer Connect	1
*	8507-516-001	Instructions, Transformer Connect (-59 Model After #)	1
2	9857-182-001	Ignition Control -39 Models.....	2
2	9857-140-001	Ignition Control -59 Models.....	2
*	9627-867-001	Harness-Ignition Control, Upper	1
*	9627-867-002	Harness-Ignition Control, Lower	1
*	9631-403-008	Wire Assembly High Voltage Upper	1
3	9631-403-009	Wire Assembly High Voltage Lower	1
4	9376-318-001	Motor.....	2
*	9453-169-009	Pulley, Motor Drive.....	1
*	9627-864-002	Harness Motor Extension.....	2
*	9506-590-001	Wiring Label Schematic/Diagram -39 models.....	1
*	9506-646-001	Wiring Label Schematic/Diagram -59 models.....	1
*	9506-965-001	Wiring Label Schematic/Diagram -59 Models (After #).....	1
*	9866-004-009	Lint Drawer Assembly Upper/Lower -39 Models.....	2
*	9866-004-001	Lint Drawer Assembly Upper/Lower -59 Models.....	2
*	9435-003-011	Overlay, Lint drawer, Blue -39 Models	2
*	9435-003-009	Overlay, Lint drawer, Blue -59 Models	2
*	8514-253-001	Operators Manual -39 Models	1
*	8514-233-002	Operators Manual -59 Models (Before serial #)	1
*	8514-310-001	Operators Manual -59 Models (After serial #).....	1
*	8502-748-001	Do Not Enter/Confined Space Warning Label.....	2
*	8502-748-006	Explosive Material Warning Label	2
*	8502-748-007	Flammable Material Warning Label	2
*	8502-748-014	Frame/Chassis Ground Warning Label	1
*	8502-748-003	Do Not Operate with Guards Removed Warning Label	3
*	8502-748-004	Do Not Operate w Guards Removed Warning Label	1
*	8502-748-005	Electrical Shock/Electrocution Warning Label	1
*	8502-748-008	Lockout Warning Label.....	1
*	8502-748-009	Read Operators Manual Warning Label	3
*	8502-748-017	Hot Surface Warning Label	2
*	8502-748-018	Do Not Touch Warning Label	1
*	8502-748-015	PE Mark (Ext. Protective Guard) Warning Label	1

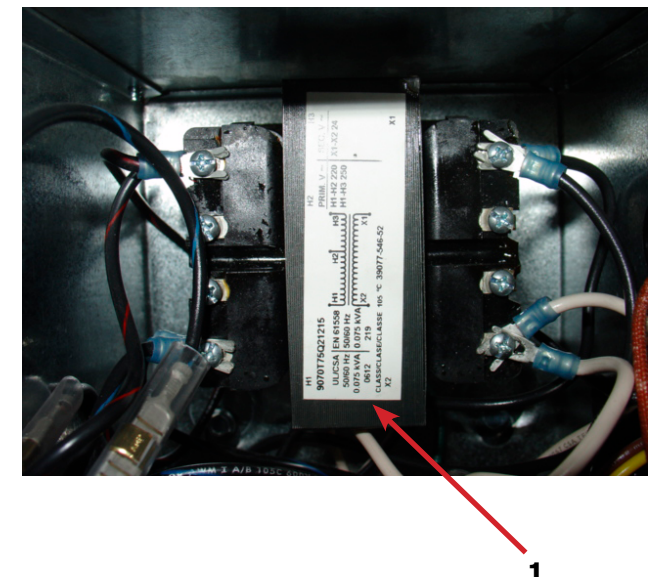
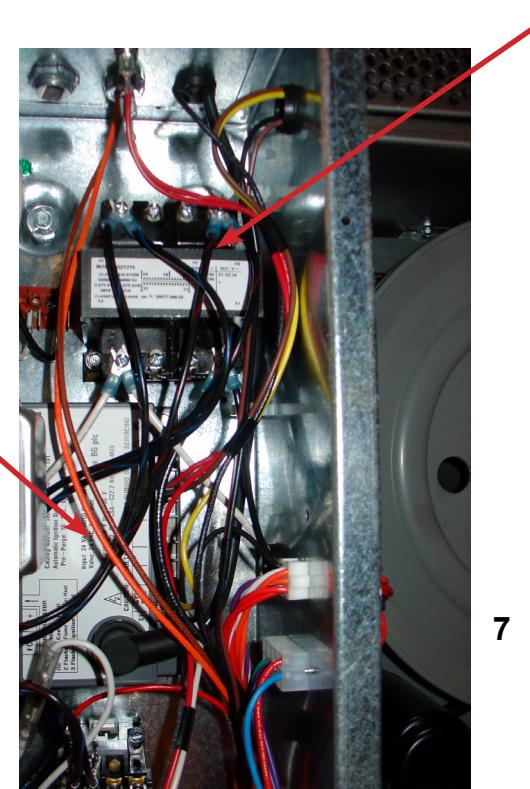
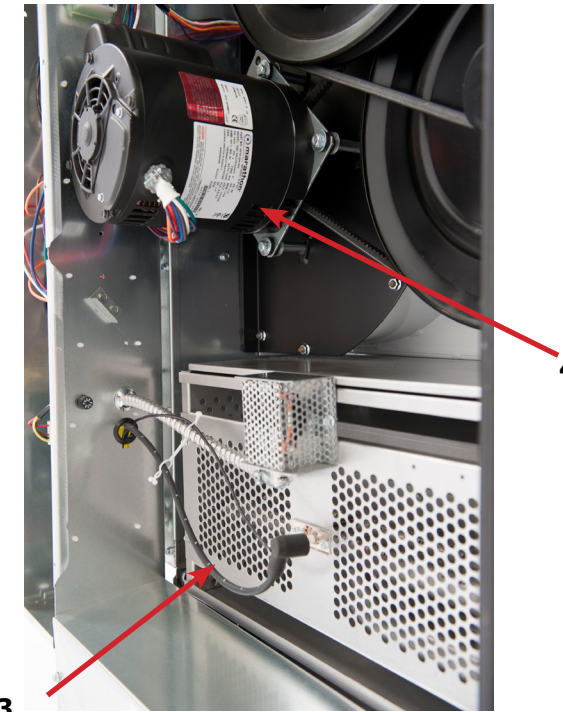

-24VAC Control Parts Group

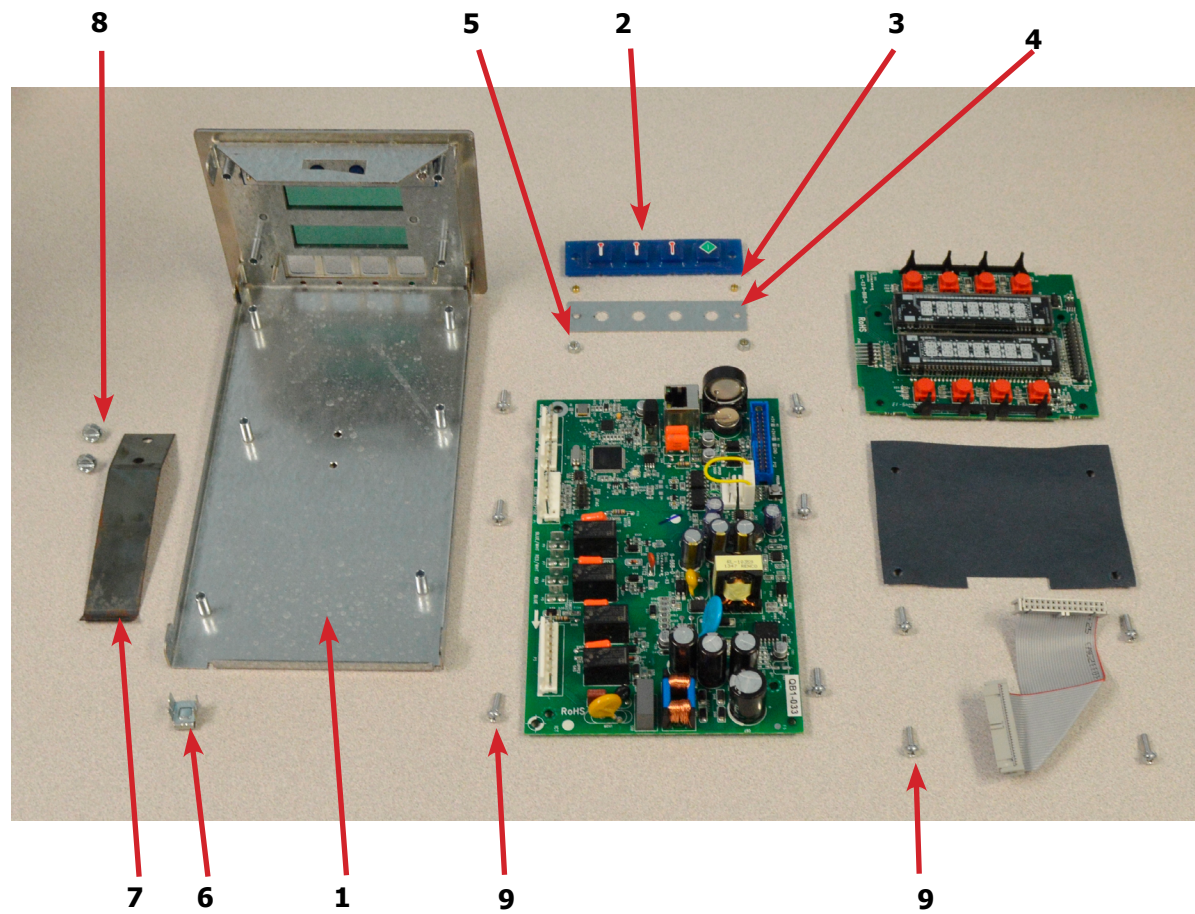

Key	Part Number	Description	Quantity
*	9857-198-002	Controls Assy, Electronic Mounted With Membrane Switch, BLU...	1
*	9857-198-004	Controls Assy, Electronic Mounted With Membrane Switch, BLK...	1
1	9826-008-001	Trough Assembly	1
2	9032-062-002	Button-Push, Control, Blue	2
2	9032-062-001	Button-Push, Control, Black.....	2
3	9538-166-011	Spacer-Metal, 4mm	4
4	9486-158-001	Retainer-Push Button	2
5	8640-424-002	Nut-Hex, Elastic stop, #4-40	4
6	8652-130-038	Terminal-Grounding clip	1
7	9534-365-001	Spring-Flat, Control	1
8	9545-008-001	Screw-Hex, #10B x 1/4	2
9	9545-044-010	Screw-Hex, #10B x 1/4	10
9	8641-582-005	Washer-External tooth, #6	10
10	9435-038-001	Overlay-Control, Coin, Black	1
10	9435-038-002	Overlay-Control, Coin, Blue	1

Note: Jumpers required if using 1.5 Control on Older Machines (P9 Connection)

*	8220-155-001	Wire Assy, Jumper, 30Lb Stack Coin	1
*	8220-155-002	Wire Assy, Jumper, 30Lb Stack Coin	1

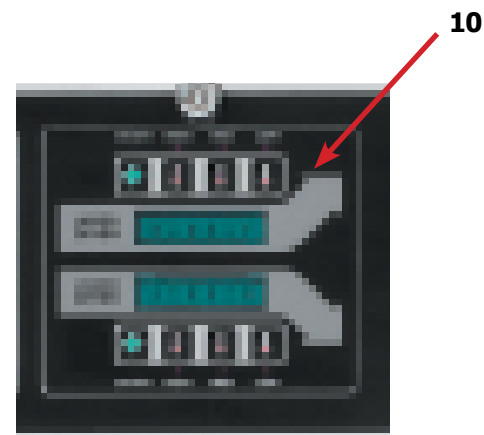

9506-965-001PR

SCHEMATIC

DC(30/50)X2N_-59CC_X-

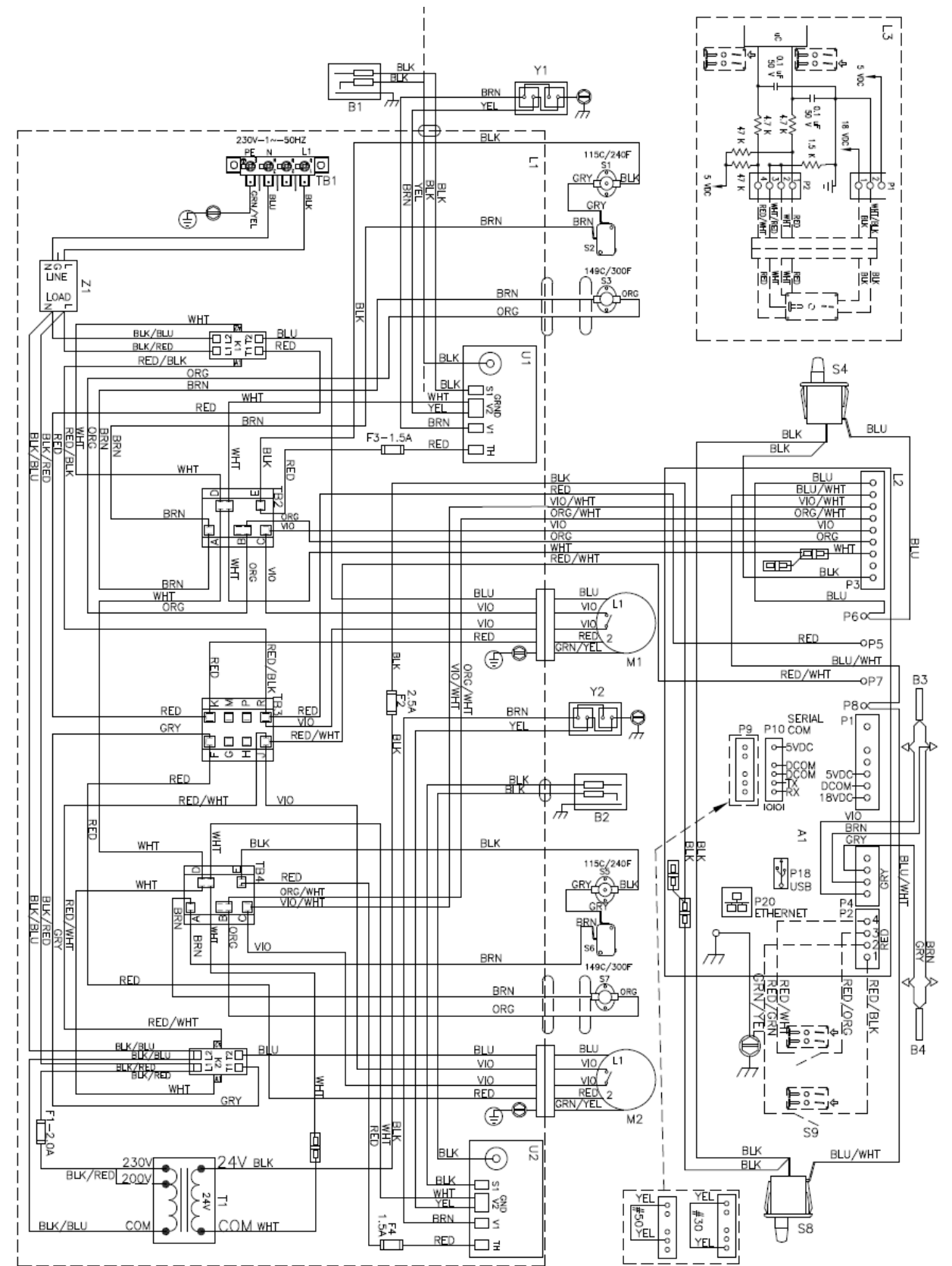
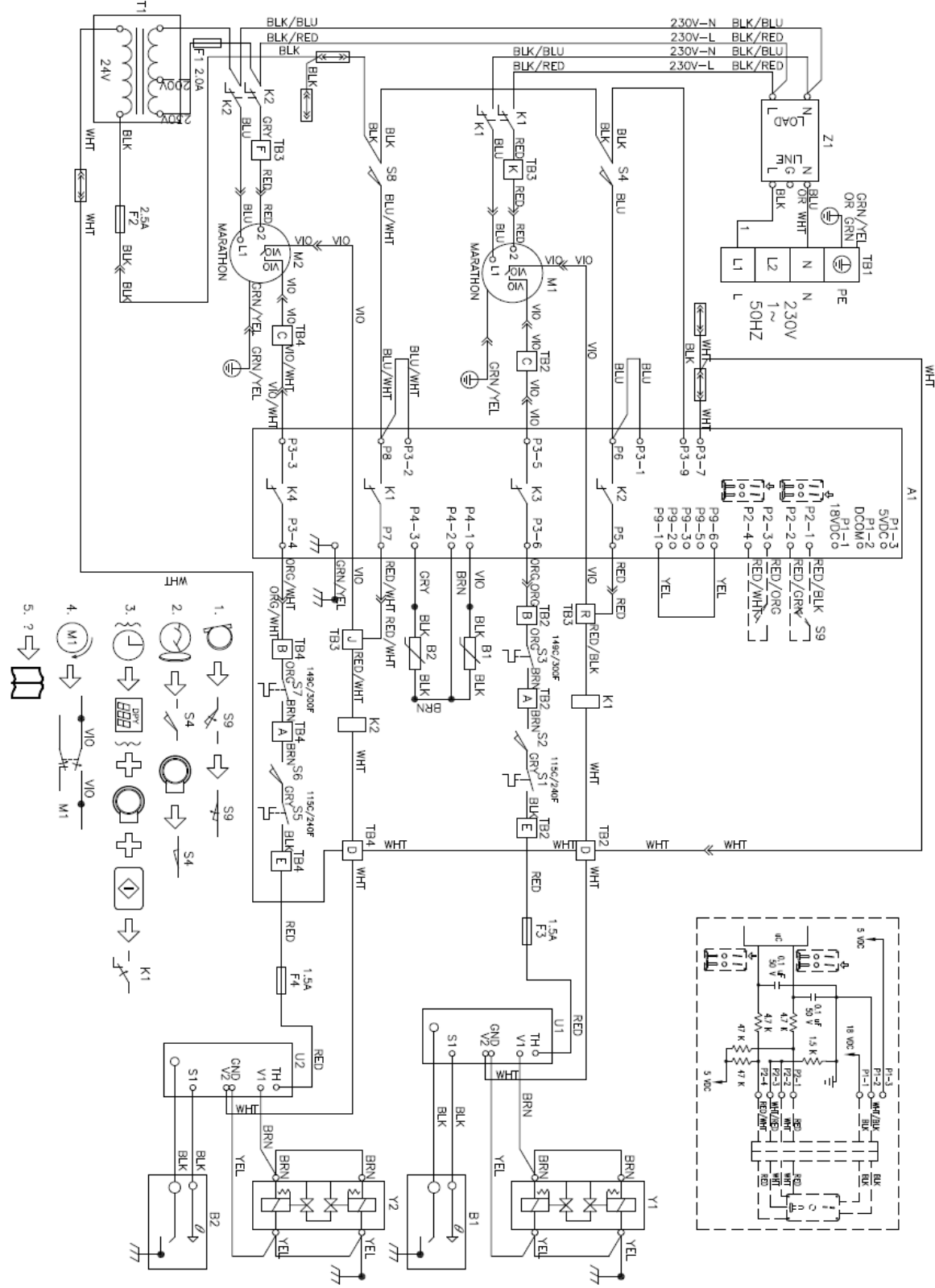

9506-965-001R WIRING DIAGRAM DC(30/50)X2N_-59CC_X-

IMPORTANT: RETAIN THIS ELECTRICAL DIAGRAM FOR SERVICE.

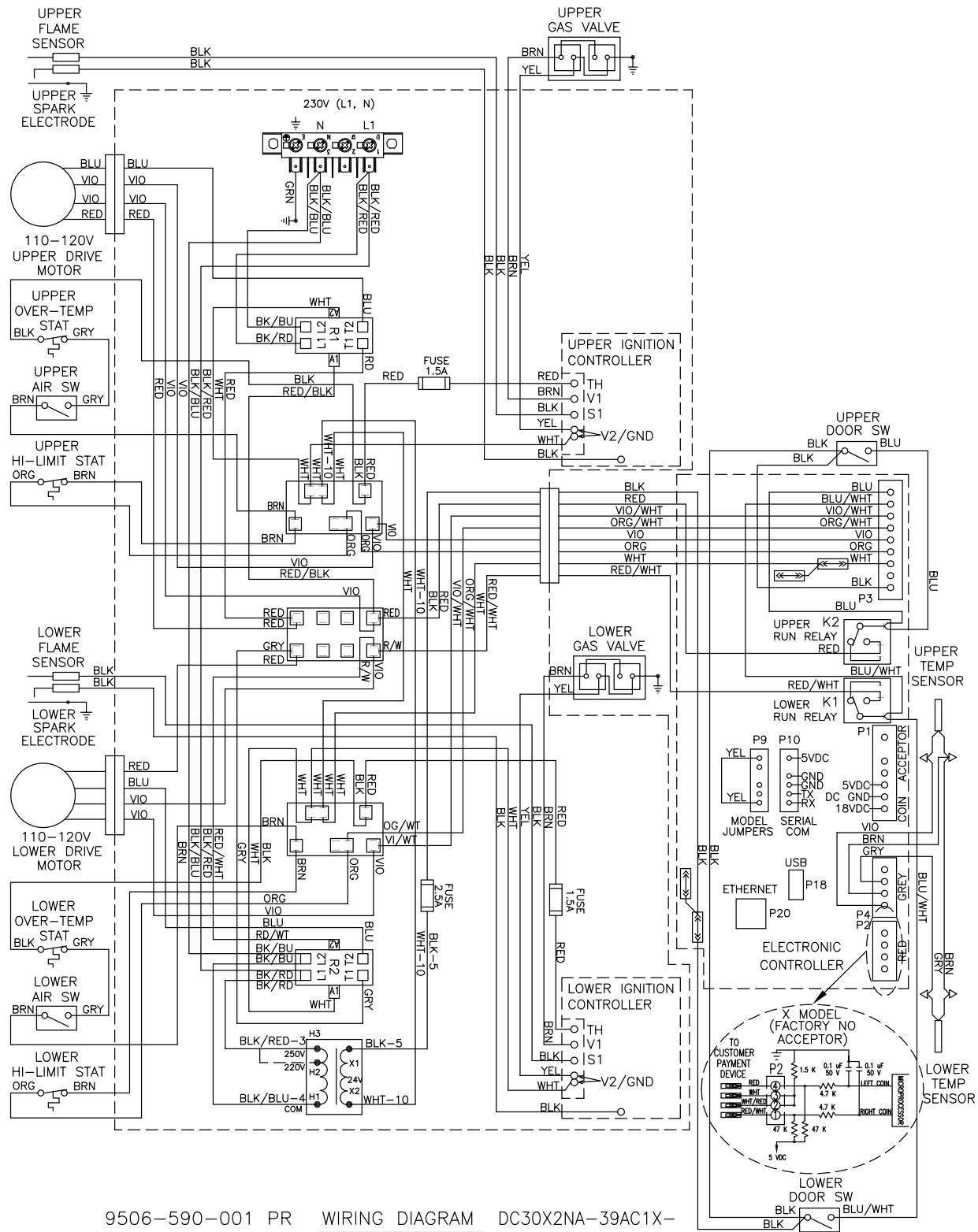

9506-590-001 PR WIRING DIAGRAM DC30X2NA-39AC1X-

IMPORTANT: RETAIN THIS ELECTRICAL DIAGRAM FOR SERVICE.

- NOTES:
1. DOOR SWITCHES ARE N.O. SWITCHES CLOSED WHEN DOOR IS CLOSED.
 2. MOTOR RUN RELAY CONTACT WILL CLOSE WHEN THE COIN COUNT IS SATISFIED, THE DOOR CLOSED AND THE START BUTTON PRESSED.
 3. REFER TO OWNERS MANUAL FOR DESCRIPTION OF OPERATION AND REQUIREMENTS FOR HEATING CIRCUIT.

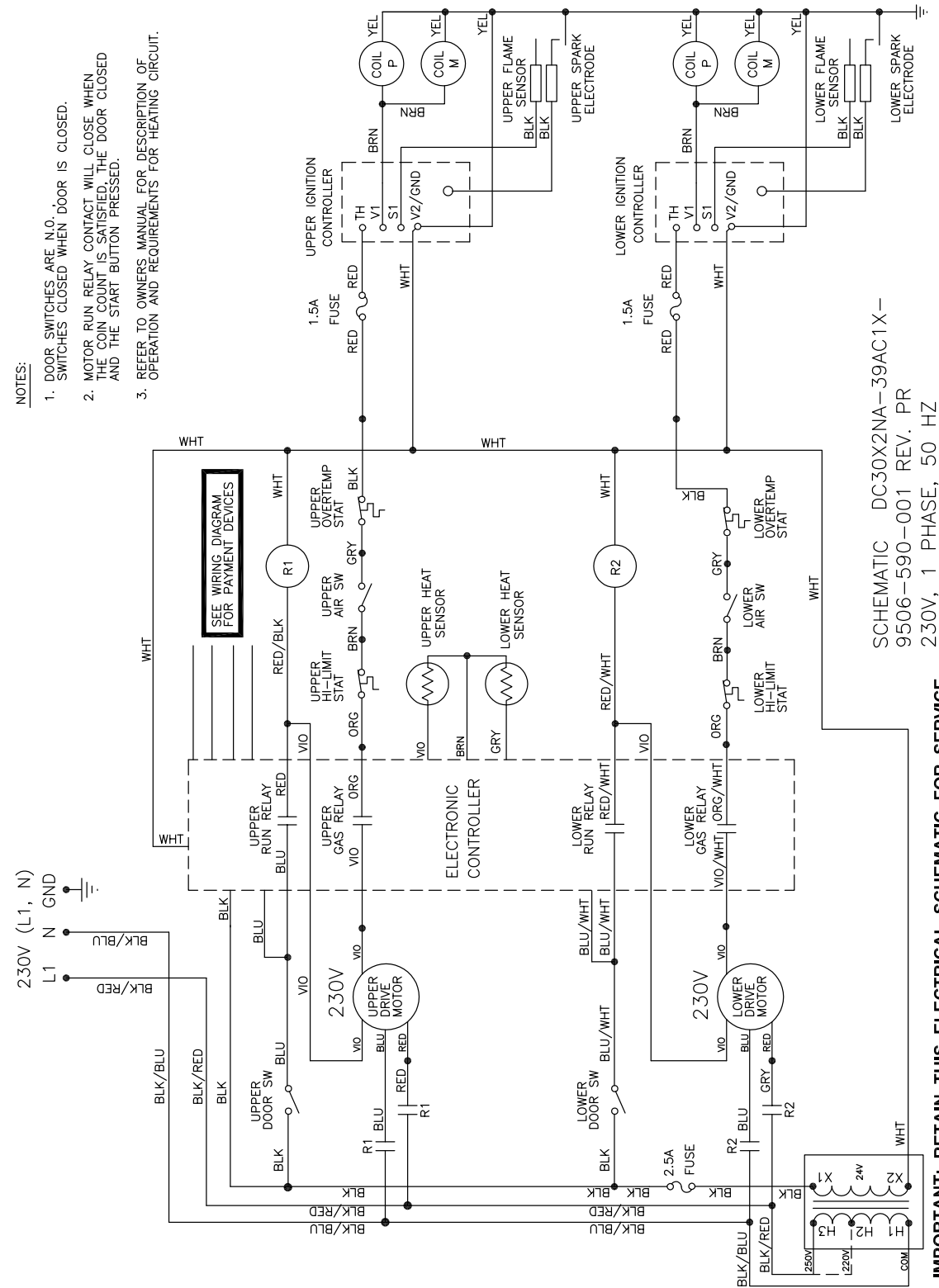

SCHEMATIC DC30X2NA-39AC1X-
9506-590-001 REV. PR
230V, 1 PHASE, 50 HZ

IMPORTANT: RETAIN THIS ELECTRICAL SCHEMATIC FOR SERVICE.

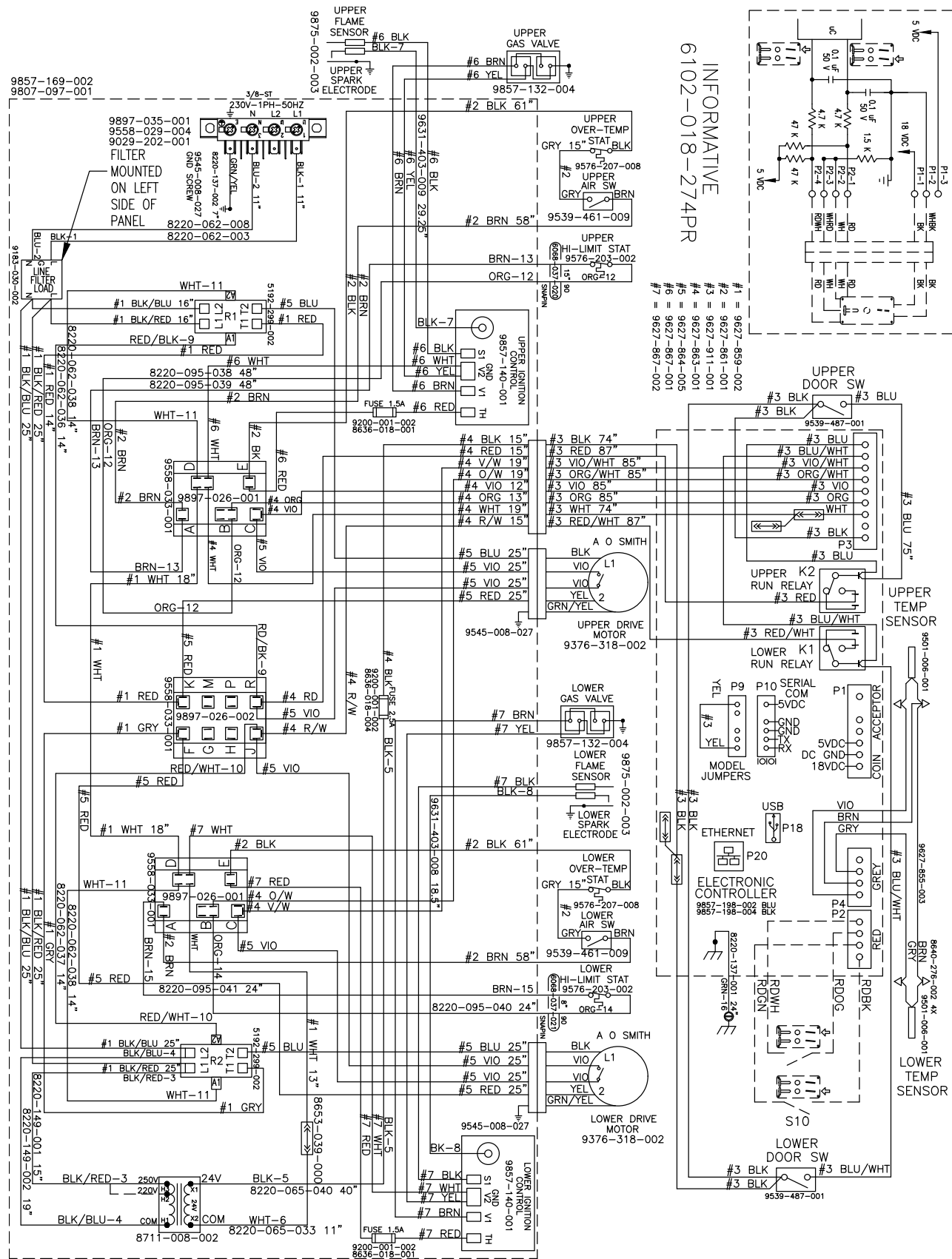

9506-646-001PR WIRING DIAGRAM DC30X2NA-59CC1X-

IMPORTANT: RETAIN THIS ELECTRICAL DIAGRAM FOR SERVICE.

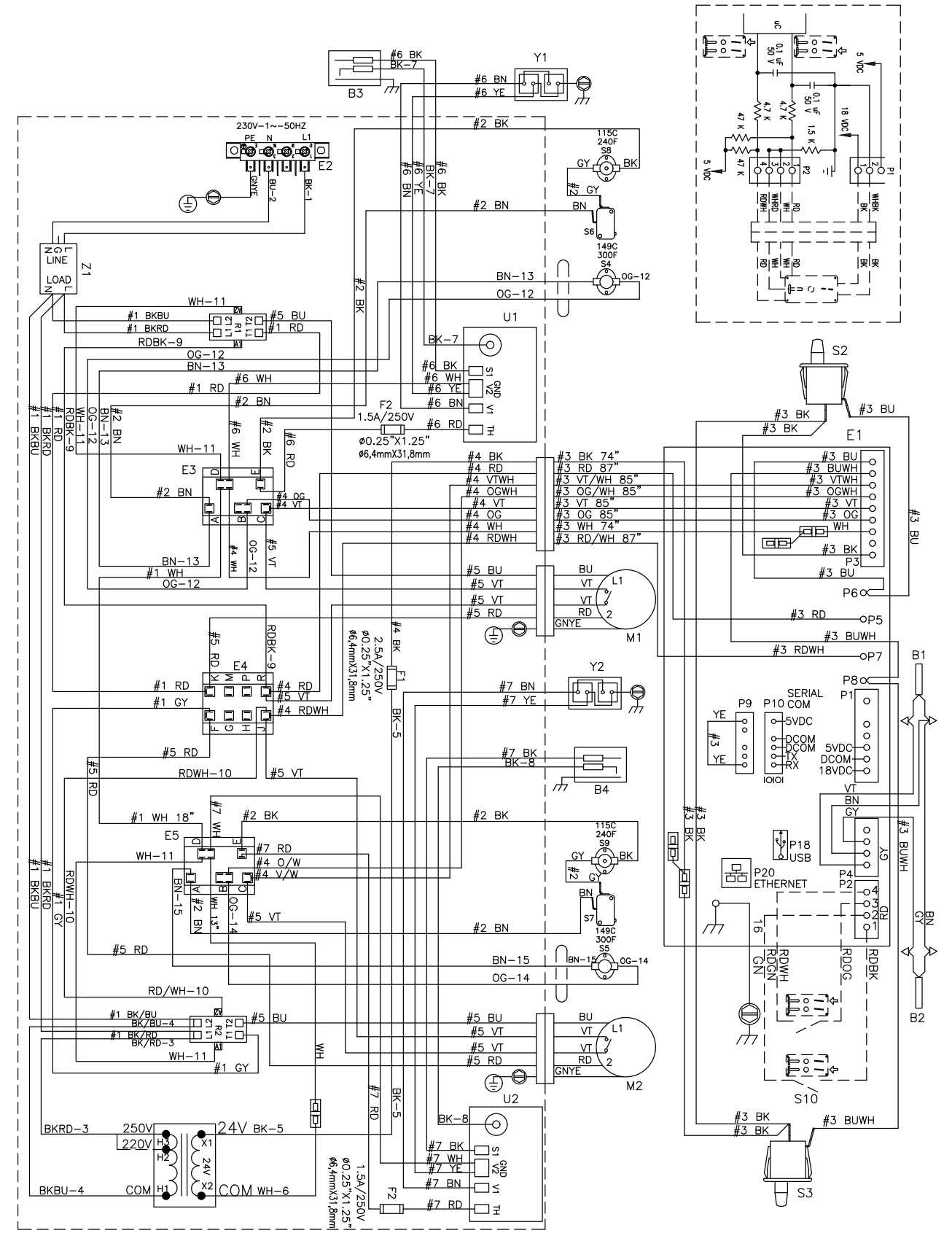

9506-646-001A WIRING DIAGRAM DC30X2N-59CC-X-

RETAIN THIS ELECTRICAL DIAGRAM FOR SERVICE.

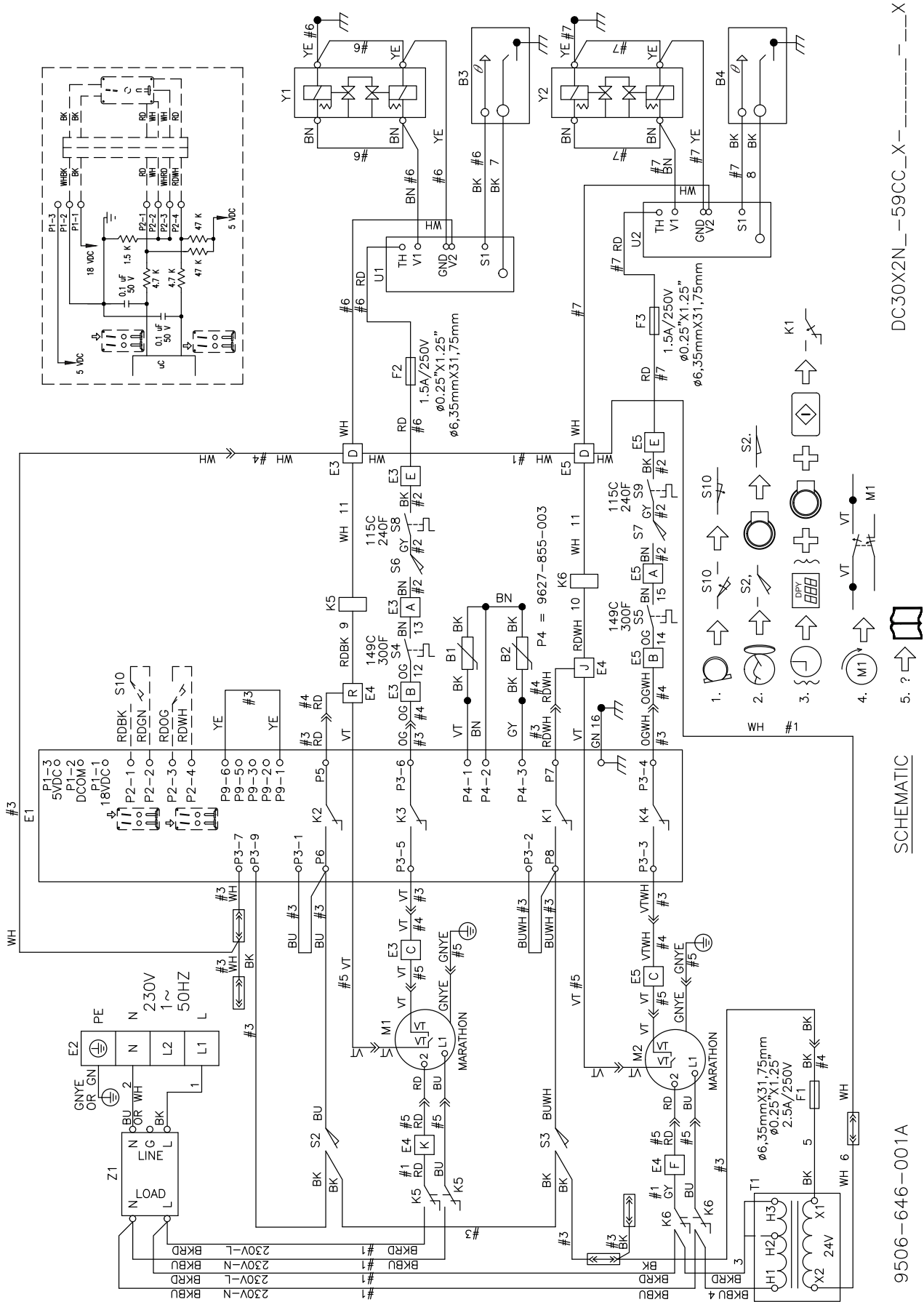

9506-646-001A

SCHEMATIC

DC30X2N_59CC_X