



DEXTER.
LAUNDRY

**USE THE BLUE TABS LOCATED ON THE
RIGHT AND LEFT SIDES OF THE FOLLOWING
DOCUMENT TO ADVANCE TO EACH SECTION.**

Kits, Assemblies, & Common Parts

Coin Acceptor Components	Part Number
Mechanical Coin Acceptor	9021-002-016
Coin Drop Screws	9545-053-002
Retainer, Coin Acceptor	9486-149-001
Loading Door Components	Part Number
Door Handle	9244-082-001
Door Close Switch	9539-461-001
Electrical Components	Part Number
Transformer, Control	8711-007-001
Transformer, Ignition	8711-002-001
Controls	9471-010-002
Heating Circuit Components	Part Number
Ignition Control Module	9857-116-003
Ignition Electrode Assembly	9875-002-003
Thermostat, Hi-Limit	9576-203-002
Thermostat, Overtemp	9576-207-006
Fuseholder	9200-001-002
Fuse 1.5 amp	8636-018-001
Airflow Switch	9539-461-009
Cabinet Components	Part Number
Cleanout Duct Assembly 8"	9973-034-001

Section 6: Parts Data

Cabinet Group

Key	Part Number	Description	Qty
•	9960-256-021	Door Assembly, Loading Complete-WHT	1
•	9960-256-022	Door Assembly, Loading Complete-ALM	1
•	9960-256-025	Door Assembly, Loading Complete-SS	1
1	9960-255-007	Door Assembly Only, Loading SS	1
2	9982-280-002	Plate Assembly, Hinge-WHT	1
2	9982-280-005	Plate Assembly, Hinge-ALM	1
2	9982-280-011	Plate Assembly, Hinge-SS	1
•	9545-012-015	Screw, Hinge to Door #10-32x 3/8	4
•	8640-413-002	Nut, Hinge to Door #10-32UNF	4
3	9212-002-003	Glass, Door	1
4	9206-164-009	Gasket, Glass	1
•	9548-117-000	Support, Door Glass (inside Gasket)	3
5	9206-420-002	Gasket, Outer Rim	1
6	9244-082-001	Handle, Loading Door	1
•	9545-018-017	Screw, Handle 1/4" 20 x 3/8"	2
•	9531-033-001	Stud, Door Catch	1
•	8640-413-001	Nut, Hex	1
•	8640-413-003	Nut, Acorn # 10-32	1
•	9086-015-002	Catch, Loading Door	1
•	8638-190-009	Rivet, Pop-Catch loading door	2
7	9454-569-005	Panel Assembly, Front WHT	1
7	9454-569-008	Panel Assembly, Front ALM	1
7	9454-569-010	Panel Assembly, Front SS	1
8	9108-084-010	Door, Upper Service WHT	1
8	9108-084-013	Door, Upper Service ALM	1
8	9108-084-014	Door, Upper Service SS	1
9	9578-085-001	Trim, Upper Service Door	1
•	9491-009-001	Rivet, Drive-Door Hinge	2
•	8641-581-005	Washer, Flat 3 /16	2
•	9548-268-001	Support, Upper Door	1
•	8650-006-003	Lock w/nut Lower Service Door	1
•	6292-006-006	Key, Service Lock (FJWCC)	1
10	9412-083-001	Nameplate, Commerical Dryer	1
•	9545-012-003	Screw, Chrome 10-32 x 1/2	4
•	8641-436-004	Washer, Fiber	4
•	8641-582-019	Lockwasher #10	10
•	8640-399-001	Nut, Spring U Type 10Z-Front Panel Clips	6
11	9544-047-002	Strap, Hinge-WHT	1
11	9544-047-005	Strap, Hinge-ALM	1
11	9544-047-007	Strap, Hinge-SS	1
•	9545-012-028	Screw, Hinge To Panel 10T-32 x 1/2	4
12	9545-052-001	Screw, Door to Hinge Strap (special)	1
•	8641-436-003	Washer, Fiber/Plastic VSCO on Door Hinge (special)	1
13	9960-243-022	Door Assembly, Lower Service WHT	1
13	9960-243-025	Door Assembly, Lower Service ALM	1
13	9960-243-026	Door Assembly, Lower Service SS	1
14	9578-081-002	Trim-Handle, Lower Service Door	1
•	9545-008-021	Screw, Pn Hd Cr-#10 x 3/8	1
15	9578-084-001	Trim, Kick-Lower Service Door	1
*	9472-001-013	Cabinet Touch Up Paint (White)	1

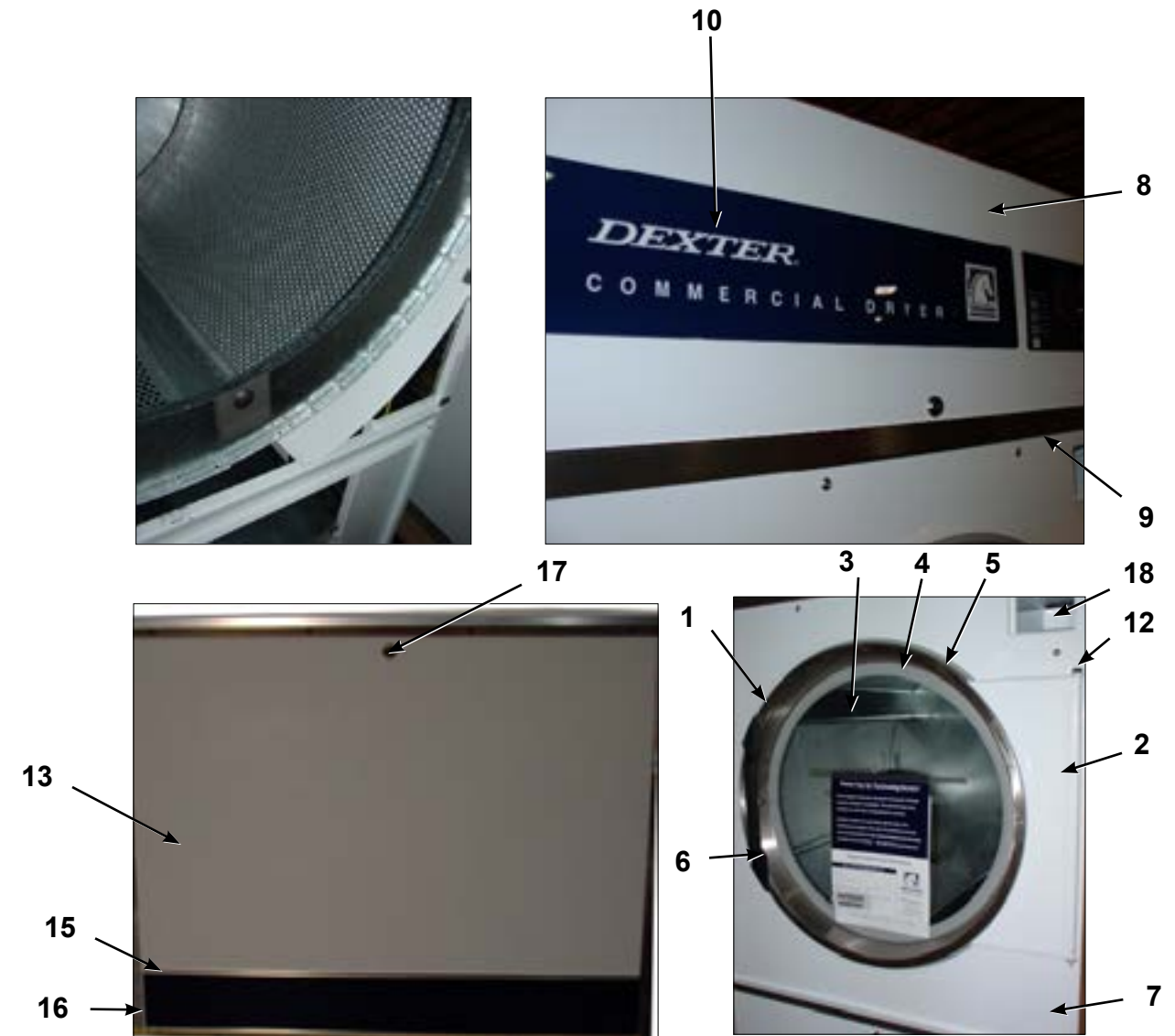

Key	Part Number	Description	Qty
16	9435-004-001	Overlay, Trim Kick	1
•	9545-008-010	Screw, Tr Hd Cr #10 x 1/2 BLK	3
17	8650-006-003	Lock w/nut Lower Service Door	1
•	8502-617-001	Label-Made in the USA	1
18	9942-027-002	Vault Assembly, Coin - SS	1
18	9942-027-004	Coin Vault Assembly White	1
18	9942-027-003	Coin Vault Assembly Almond	1
•	9807-099-001	Box Assembly Coin Vault ESD W/lock & Key Chrome	1
•	9277-041-002	Insulation Side Pannel	1
•	9277-041-004	Insulation Side Pannel	1
•	9277-047-001	Insulation 1/4" Black Top LH Side Burner Area	1
•	9277-047-002	Insulation 1/4" Black Service Door	1
•	8544-006-001	Leg, Leveling	4
*	8545-061-002	Leveling Leg Wrench	1
•	9545-008-003	Screw, #10 x 1/2 TEK	8
•	9074-236-001	Cover, Cabinet	1
*	8640-413-004	Nut, Elastic Stop	*

Front Control Housing Group

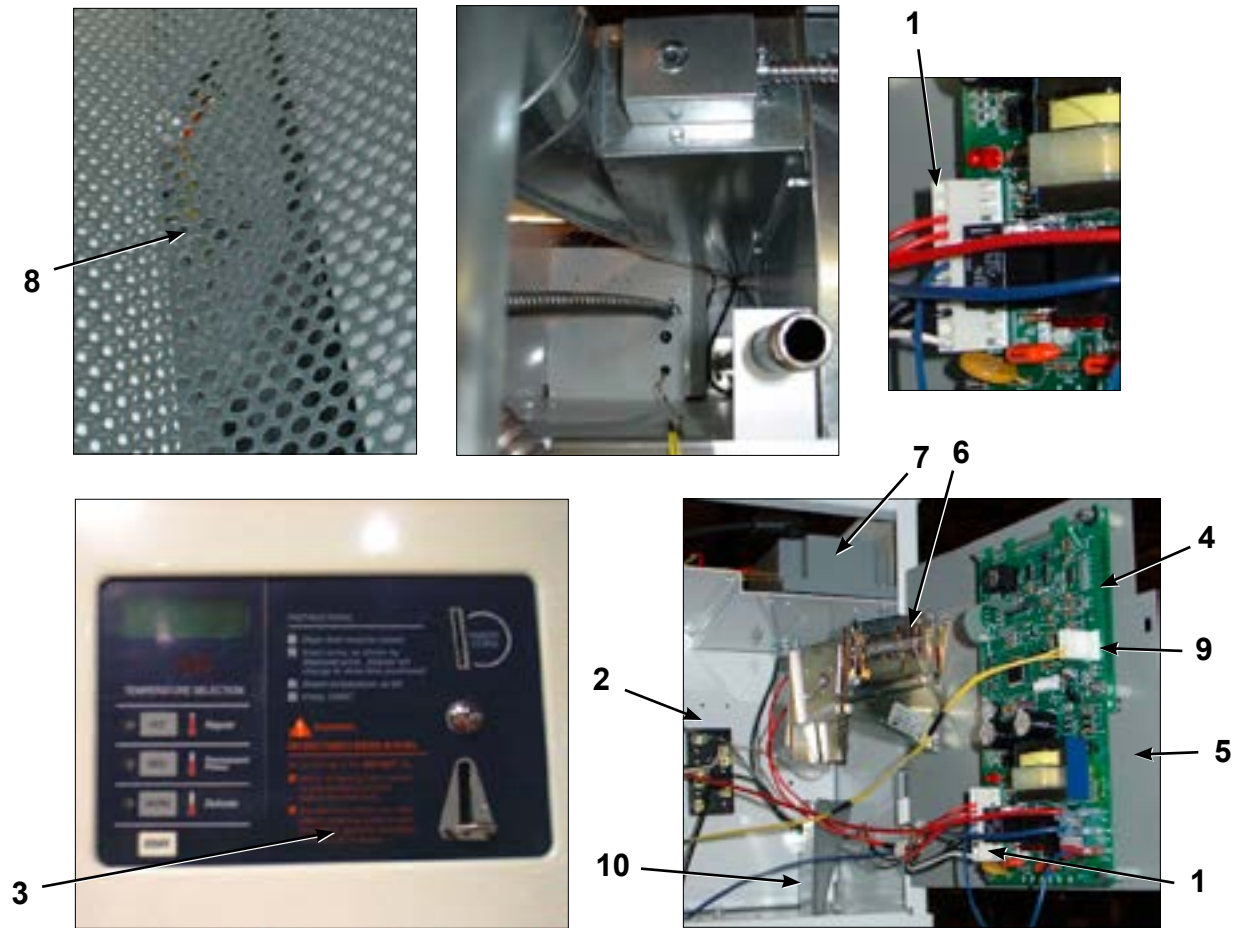

Key	Part Number	Description	Qty
1	9627-651-002	Harness Assembly, Micro	1
2	9897-026-001	Terminal Block Assembly	1
•	9545-031-004	Screw, 6AB x 3/8" (for Terminal Block)	2
3	9801-077-001	Membrane, Switch Assembly	1
3	9801-058-005	Membrane Switch Assembly (DLC30 Only)	1
4	9471-010-002	PCB Board Control	1
•	8651-053-003	Plug, Button	1
5	9982-305-002	Plate Assembly, Control Mounting	1
•	9451-146-005	Pin-Hinge Meterplate	2
6	9021-002-016	Acceptor-Coin 25¢	1
•	9054-045-001	Fuse Holder	1
•	8636-018-001	Fuse 1.5 Amp	1
•	8711-002-001	Transformer-Control	1
7	9857-116-003	Control, Ignition	1
•	9627-650-001	Harness Assembly, Low Voltage	1
•	9631-403-001	Wire Assy High Voltage (From Ignition Control)	1
8	9501-004-002	Temperature Sensor	1
9	9627-679-002	Wire Harness, Temp Sensor	1
•	8640-276-005	Nut, Wire connector 71B, BLK	2
•	9452-614-001	Bracket Sensor Mounting	1
•	9545-045-005	Screw, Mounting Bracket 8B x 1/4	1
10	9940-013-001	Coin Chute Assembly	1

Drive Group

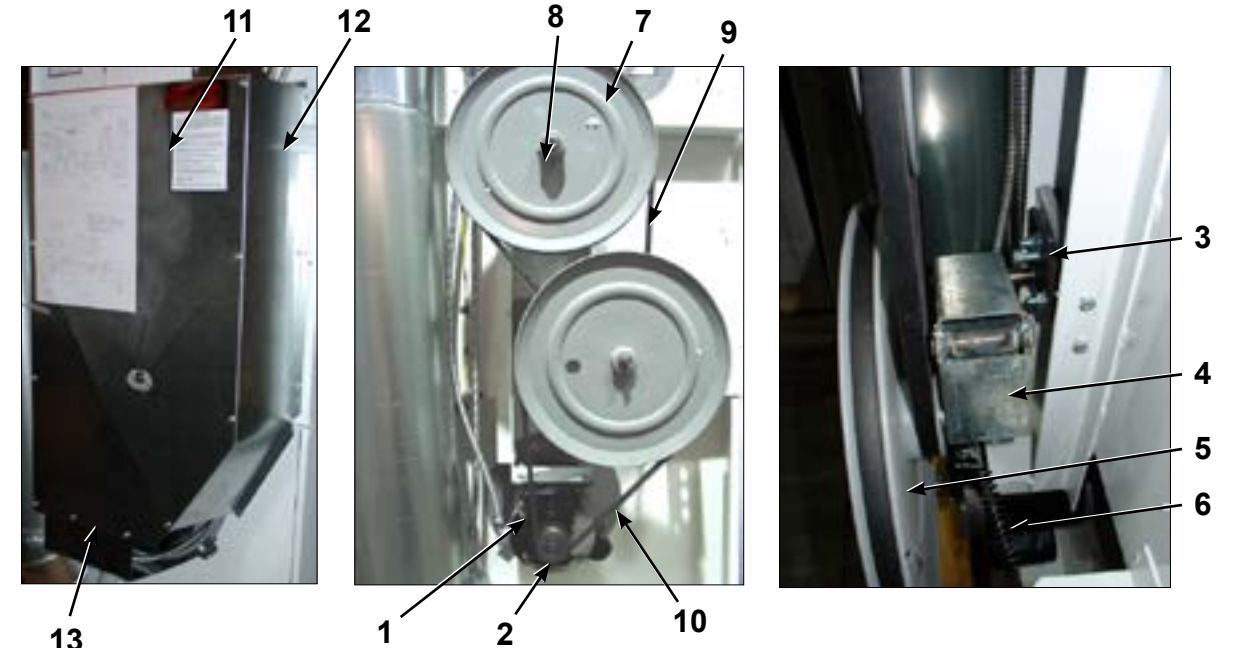

Key	Part Number	Description	Qty
1	9376-259-006	Motor, Drive AO Smith before serial #210650	1
*	9732-205-006	Motor Replacement Kit	1
*	5191-106-001	Capacitor, AO Smith Motor Start	1
1	9376-311-001	Motor, Marathon after serial #210650	1
*	5191-107-001	Capacitor, Marathon Motor Start	1
•	9545-014-004	Screw, Hx 5/16-18 x 5/8	4
•	8640-400-003	Nut 5/16 - 18	4
2	9453-157-001	Pulley - Motor	1
•	9545-028-013	Screw, Set	2
3	9991-053-002	Support Assembly, Intermediate Pulley	1
•	9545-029-010	Bolt, Rd Hd, 3/8-16 x 1 1/4	3
•	9545-029-012	Screw, 3/8-16 x 1 1/2	1
•	8640-415-004	Nut, 3/8-16	3
•	8641-581-035	Washer, Flat	3
4	9861-022-001	Arm Assembly-Tension Complete	1
*	9861-015-001	Tension Arm (Short) DLC30 Only	1
*	9861-016-001	Tension Arm DLC30 Only	1
5	9908-039-001	Pulley Assembly, Intermediate-W/Bearings	1
•	9036-145-002	Bearings, Bronze Flange	2
•	9487-200-003	Ring, Retaining	3
6	9534-319-002	Spring, Belt Tension	1
•	8641-581-035	Washer, Flat	2
7	9908-040-001	Pulley Driven	1
•	9306-006-000	Key, Woodruff	1
8	8640-222-000	Nut, 1"-14	1
•	8641-582-015	Washer,Lock Internal Tooth	1
9	9040-073-004	Belt, Final Drive	1
10	9040-077-002	Belt, Motor Drive	1
11	9208-065-001	Guard, Drive	1
*	9545-008-024	Guard Screws	*
12	9454-596-002	Pannel, Drive Guard, RH	1
•	9454-595-002	Pannel, Drive Guard, LH	1
13	9550-190-001	Shield, Motor	1
•	9545-008-003	Screw 10-16 x 1/2, TEK	2

Burner Housing Group

Key	Part Number	Description	Quantity
1	9803-163-002	Housing Assembly, Burner Welded	1
•	9545-008-024	Screw 10AB x 3/8	2
2	9048-018-001	Burner, Main	3
•	9545-008-008	Screw 10 T-32 x 1/4"	3
3	9875-002-003	Electrode, Ignition	1
•	9985-161-001	Bracket Assembly, Electrode Mounting	1
•	9545-008-024	Screw, Electrode Mtg 8B x 10x 3/8"	2
4	9857-134-001	Control Assy, Gas	1
5	9381-009-001	Manifold, 2 port	1
•	9425-069-002	Orifice, Burner-Natural #30	2
•	9425-069-003	Orifice, Burner-LP #48	2
6	9576-203-002	Thermostat, Hi-Limit	1
•	9538-142-001	Spacer, Hi-Limit	2
•	9545-045-007	Screw 8B x 3/4"	2
7	9074-234-001	Cover, Hi-Limit Stat	1
•	9545-008-024	Screw 10 B x 3/8"	1
8	9857-116-003	Control, Ignition (Gray Box)	1
•	9545-044-002	Screw 6-32 x 1"	2
•	8640-411-003	Nut, Hex Keps 6 x 32	2
9	9897-026-001	Terminal Block Power (Inside Control Panel)	1
•	9545-031-004	Screw 6 AB x 5/8"	2
•	9039-915-001	Bracket, Pipe gas line	1
•	9545-008-003	Screw 6AB x 5/8"	2
10	9631-403-001	Wire Ass'y, High Voltage	1
11	9627-650-001	Harness, Low Voltage Ignition	1
12	9054-045-001	Fuseholder	1
13	8636-018-001	Fuse 1.5 amps	1
•	8711-007-001	Transformer, Control	1
•	9545-012-009	Screw, 10x1/2"	2
•	9732-102-003	Kit, LP Conversion	1
•	9548-256-001	Support, Front Burner	1
•	9545-008-008	Screw 10T-32 x 1/2"	3
14	9379-164-001	Valve, Gas Shut-Off w/ brass union (Optional)	1
•	9458-020-003	Pipe, Gas Line	1
•	9918-002-002	Recirculation Boot	1
•	9545-008-024	Screw, 10AB x 3/8"	7
•	9576-207-006	Thermostat, Over Temp-Manual Reset	1
•	9545-045-008	Screw, 8AB x 3/8"	2
16	9825-057-002	Cover, Over Temp Thermostat	1
•	9545-008-024	Screw, 10AB x 3/8"	2

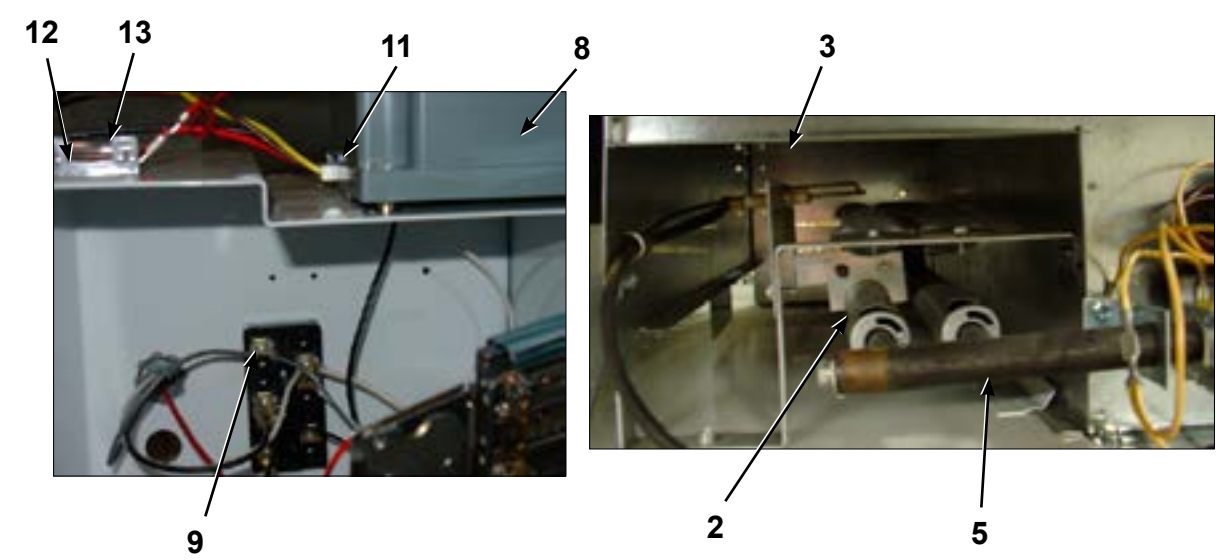
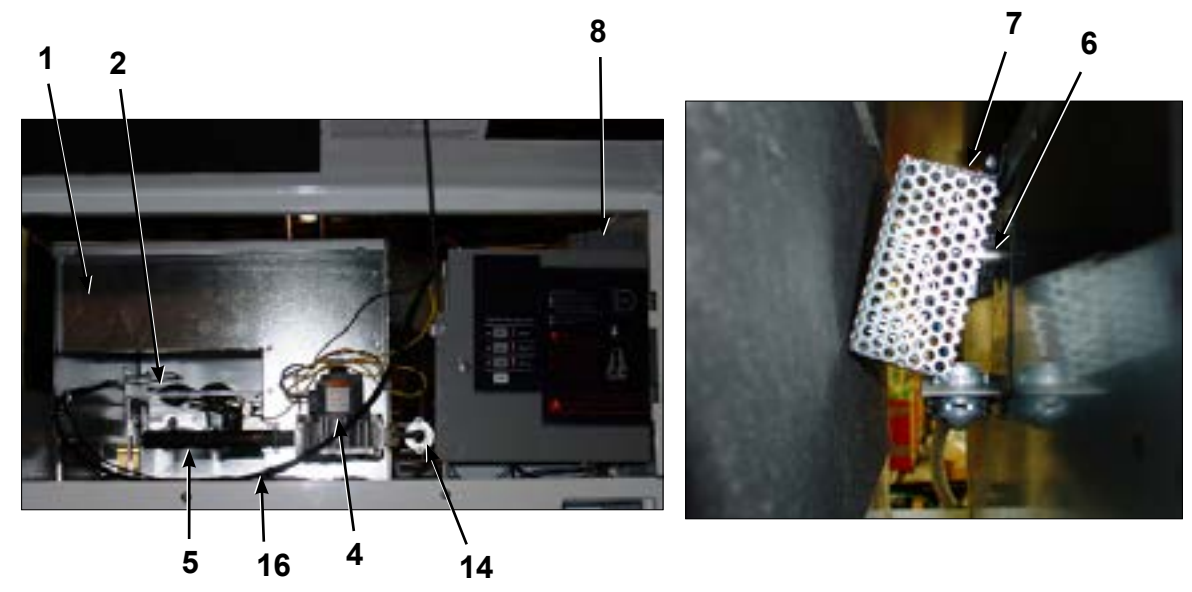
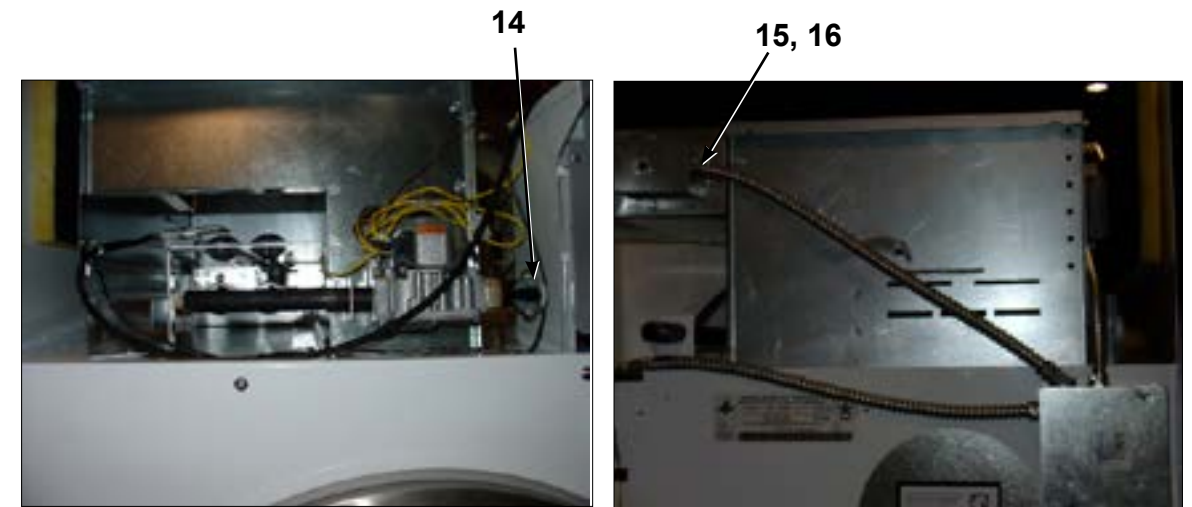

Bearing Housing Group

Key	Part Number	Description	Quantity
*	9803-160-002	Housing, Bearing Ass'y w one(rear) bearing	1
1	9241-161-001	Housing, Bearing	1
2	9036-130-001	Bearing, Ball-Rear	1
*	9036-130-001	Bearing, Ball-Front	1
	9538-139-001	Spacer, Bearing	1
3	8641-581-009	Washer, Flat 3/8"	4
4	8641-582-003	Lockwasher spring 3/8"	4
5	9545-049-002	Screw 3/8" x 3/4"	4
6	8640-415-002	Nut, 3/8"	2
*	8640-400-002	Nut, 5/16"	4
*	8640-222-000	Nut, Tumbler Shaft	1
*	9306-006-000	Key, Tumbler Shaft	1
*	9908-040-001	Pulley Drive	1
*	9552-013-003	Shim	1
8	9545-049-001	Screw 3/8" x 1"	2

* Not Illustrated

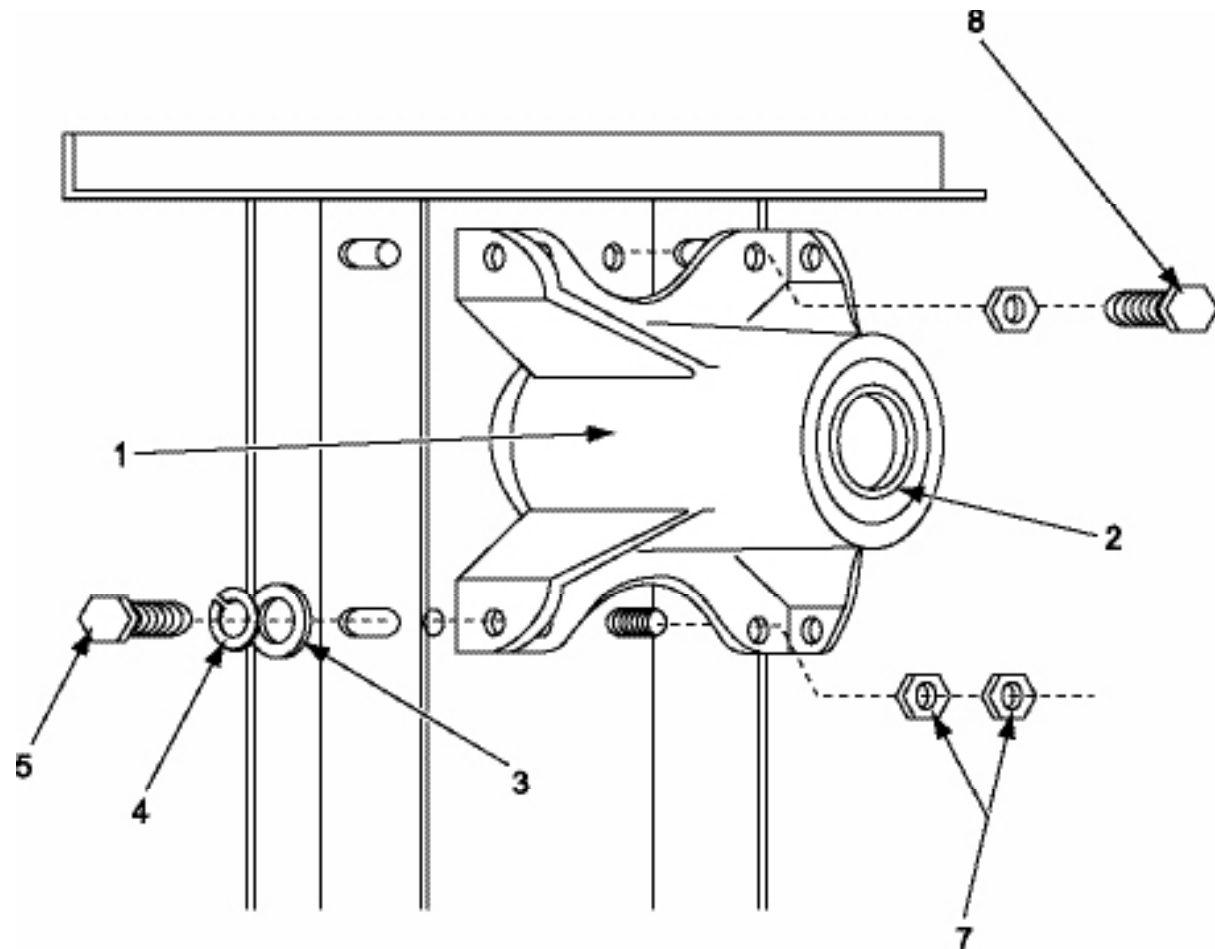

Tumbler Basket Group

Key	Part Number	Description	Quantity
1	9848-101-001	Tumbler Assy	1
*	9848-128-002	SS Tumbler	1
2	9568-012-001	Spider & Shaft Assy	1
3	9497-019-001	Rod, Tumbler	3
4	8640-415-004	Nut, Tumbler Rod	3
5	9552-013-003	Shim	AR
7	8641-554-001	Washer, Tumbler Rod (special)	3
8	9306-006-000	Key, Tumbler Shaft	1
9	8641-582-015	Lock Washer, Tumbler Shaft	1
10	8640-222-000	Nut, Tumbler Shaft	1
*	9848-129-001	Tumbler w/ Spider	1

* Not Illustrated

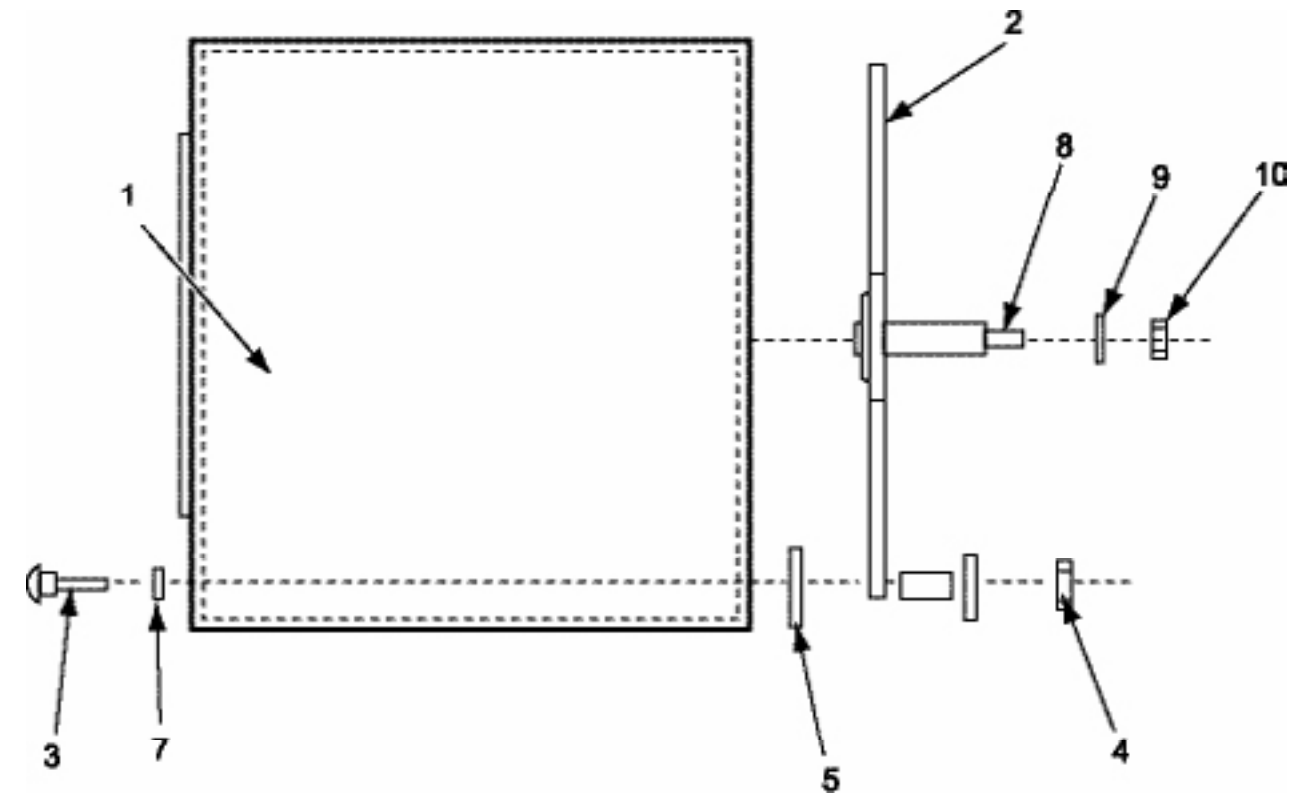

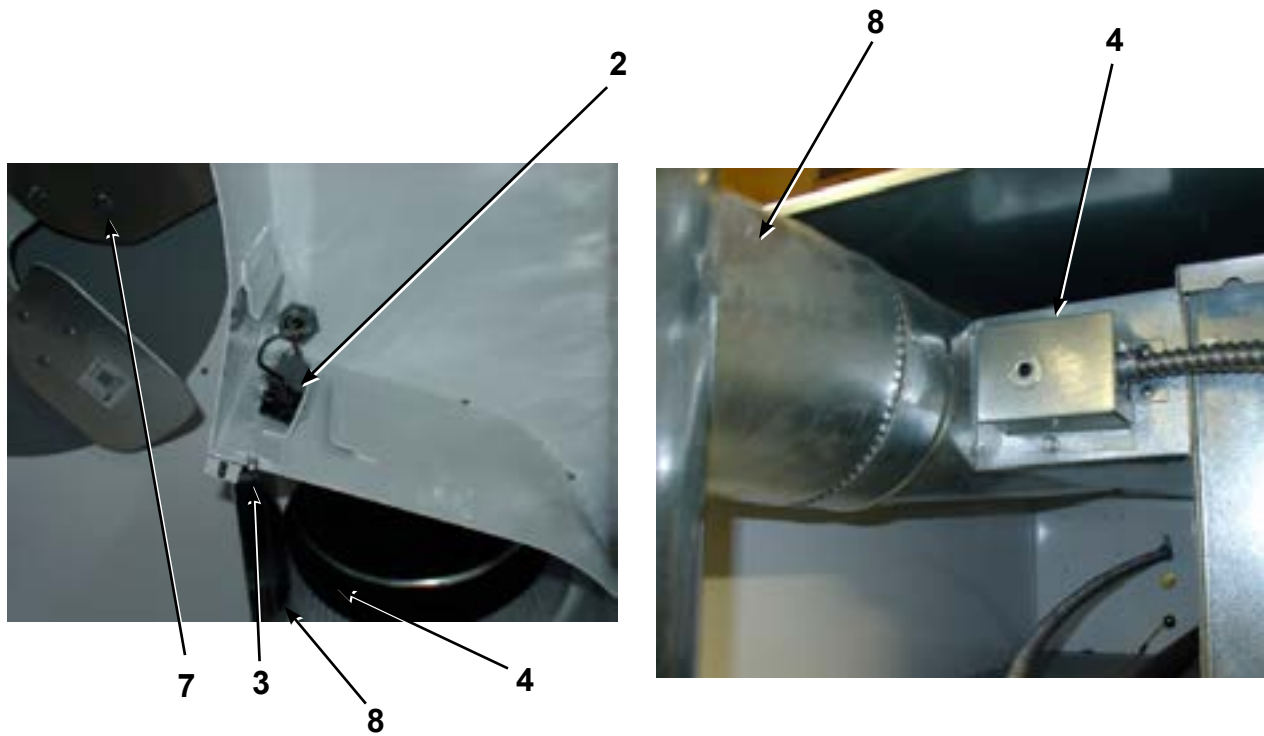

Blower Impeller and Air Flow Switch Group Over Temperature Switch

Key	Part Number	Description	Quantity
•	9074-242-001	Cover Damper Switch.....	1
1	9125-001-001	Damper.....	1
•	9545-044-002	Screw Switch Mtg.	2
2	9539-432-001	Switch Damper	1
•	8640-411-003	Nut Switch Locking	1
•	8640-420-001	Nut Twin.....	1
3	9451-146-001	Pin Damper.....	1
4	9825-057-002	Over-tempcoverass'y	1
•	9576-207-006	Thermostatover-tempMnl.....	1
•	9545-045-008	Screw 10B x 3/8.....	2
•	9486-137-001	Retainer pushon	1
•	9535-050-003	Sleeve-Hi-Limitswitcaccess	1
5	9822-027-002	Hood Ass'y, Lint	1
•	8640-412-004	Lint Hood Mtg.	6
6	9822-026-001	Lint Screen.....	1
7	9278-037-002	Impeller, w/set screws.....	1
•	9545-028-013	Set Screw.....	2
8	9918-002-002	Recirculation Boot.....	1
*	9973-034-001	8" Slide Open Clean Out Duct (Optional).....	1

* Not Illustrated

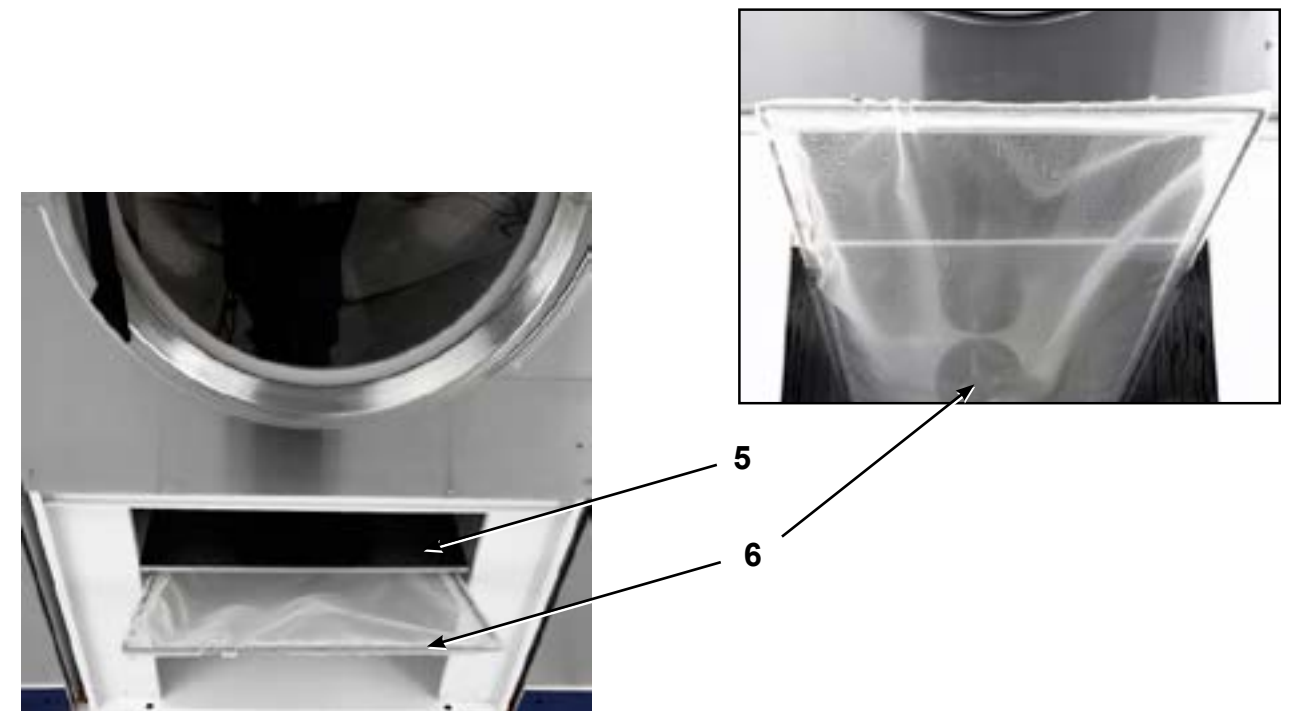
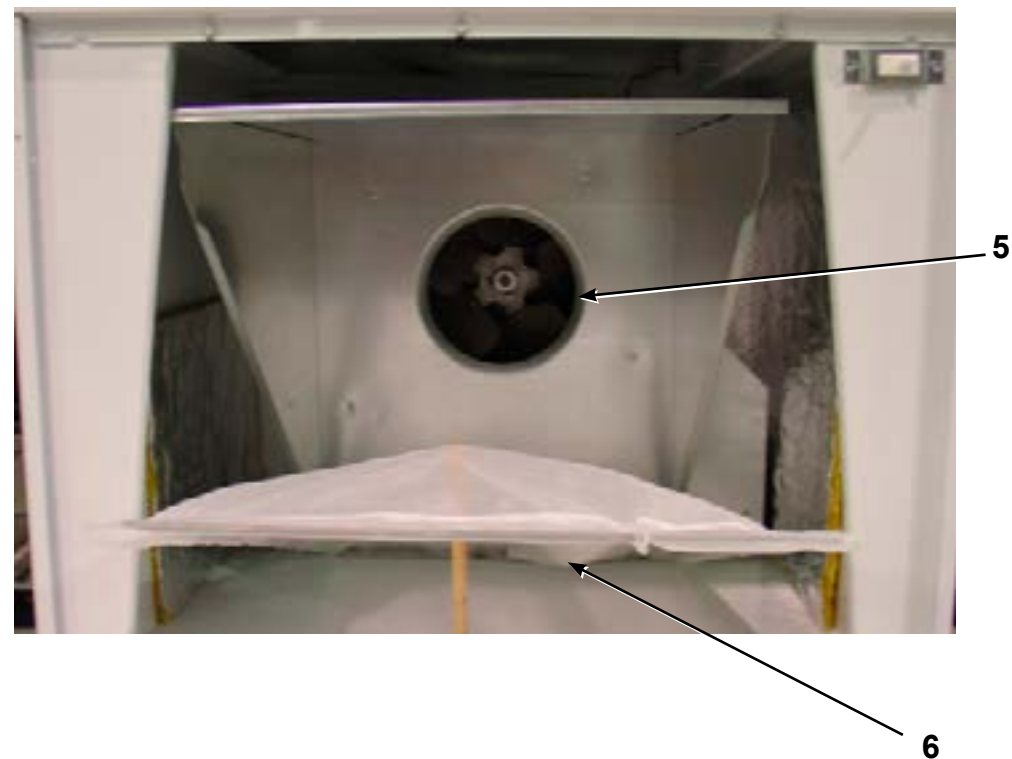

Wire & Harness Group

Key	Part Number	Description	Qty
	9627-651-002	Harness, Control.....	1
	9627-679-002	Wire Harness, Temp Sensor.....	1
	8640-276-005	Nut, Wire connector 71B, BLK.....	2
	9627-650-001	Harness Assembly, Low Voltage.....	1
	9631-403-001	Wire Assy, High Voltage (From Ignition Control).....	1
	9054-045-001	Fuse Holder.....	1
	8636-018-001	Fuse, 1.5 Amp.....	1
	9897-032-002	Terminal Block, Rear Control Box.....	1
	8220-064-044	Wire Assy, BLK 58", Power Terminal Block to Block.....	1
	8220-064-041	Wire Assy, WHT 58 1/2", Power Terminal Block to Block.....	1
	8220-101-022	Wire Assy, WHT 62", Terminal Block to Motor.....	1
	8220-101-021	Wire Assy, RED 62", Terminal Block to Motor.....	1
	8220-057-034	Wire Assy, BLU 62", Terminal Block to Motor.....	1
	8220-064-046	Wire Assy, BRN 70", Terminal Block to Air Flow Switch.....	1
	8220-064-045	Wire Assy, ORG 67", Terminal Block to Air Flow Switch.....	1
	8220-064-042	Wire Assy, GRY 57", Terminal Block to Terminal Block.....	1
	8220-101-025	Wire Assy, GRY 25 1/2", Terminal Block to Over Temp Switch....	1
	8220-101-026	Wire Assy, ORG 27", Terminal Block to Over Temp Switch.....	1
	8220-101-024	Wire Assy, BRN 29 1/2", Terminal Block to High Limit Switch.....	1
	8220-101-027	Wire Assy, BLU 28", Terminal Block To High Limit Switch.....	1
	8220-064-043	Wire Assy, RED 78 1/2", Terminal Block To Control Board.....	1
	8220-001-225	Wire Assy, RED 9" Transformer to Fuse Holder.....	1
	8220-127-001	Wire Assy, Black 48" Terminal Block to Door Switch.....	1
	8220-127-002	Wire Assy, Blue 65" Terminal Block to Door Switch.....	1
	8653-039-000	Connector-Wire, Line 1/4".....	1
	8711-002-001	Transformer, Control 120/24 VAC.....	1

Label Group

Key	Part Number	Description	Qty
	8507-256-001	Instructions, Uncrating.....	1
	8514-003-010	Owner's Booklet.....	1
	8507-350-001	Instructions, Dryer Install / Start Up.....	1
	8507-330-001	Instructions TVSS.....	1
	9506-047-002	Wiring Schematic.....	1
	9506-048-002	Wiring Diagram.....	1
	8511-001-002	Label, Quality.....	1
	8527-105-001	Label, Decal Lighting and Clearance.....	1
	8502-645-001	Label Instructions.....	1
	8502-600-001	Label, Warning and Notice.....	1
	8502-640-004	Label, Instructions.....	1

Label With Electronic Coin Acceptor Parts

Key	Part Number	Description	Qty
	8220-001-338	Wire Assembly-6" BLU, Transformer to Terminal Block.....	1
	8502-725-001	LABEL-INSTRUCT/WARN,ELECTRCOIN.....	1
	8502-730-001	LABEL-WARNING,ELECCOINACCEPTOR.....	1
	8640-411-002	NUT-ELASTICSTOP,#6-32.....	2
	8640-424-002	NUT-HEXELASTICSTOP,#4-40.....	3
	8711-003-001	TRANSFORMER-120/12VAC.....	1
	9021-014-002	ACCEPTOR-COIN,ELECTRONIC(108).....	1
	9452-724-001	PLATE-MOUNTING,COMPUTERCONTROL.....	1
	9506-072-002	WIRINGLABEL-SCHEMATIC.....	1
	9506-073-002	WIRINGLABEL-DIAGRAM.....	1
	9531-040-002	STUD-SELFCLINCHING,#4-40X3/8.....	3
	9545-044-006	SCREW-PNHDCR,#6-32X5/16.....	2
	9627-651-003	WIRINGHARNESSELECTRONICCNTRL.....	1
	9982-334-002	PLATEASY-CONTROLSMNTNG(CMPTR).....	1

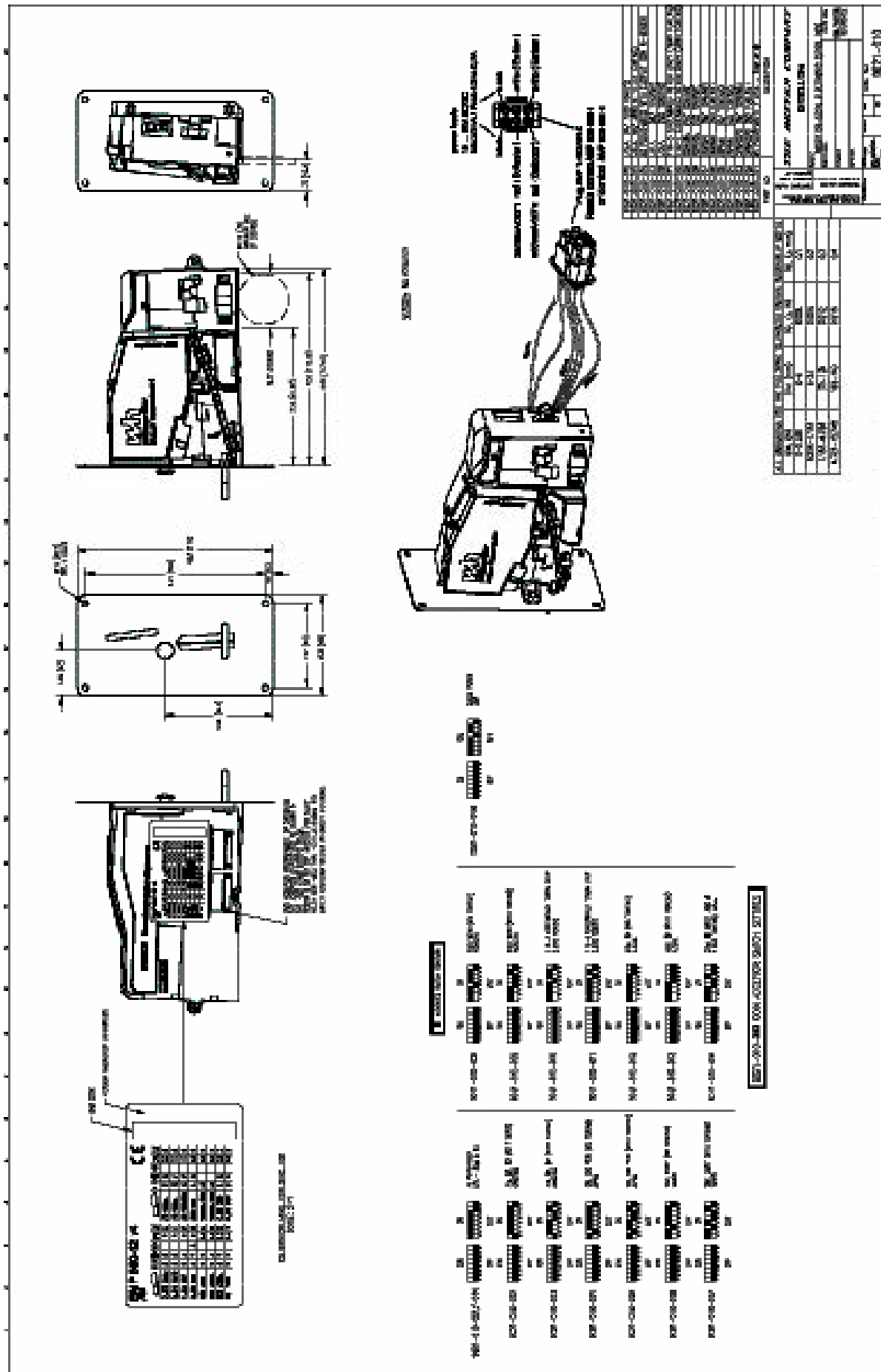

EC Models (Intergrated EasyCard Ready Parts)

Key	Part Number	Description	Qty
	8502-728-001	LABEL-INSTRUCTIONS/WARNING,EC	1
	8640-412-005	NUT-HEXKEPS,#8-32	2
	8640-424-002	NUT-HEXELASTICSTOP,#4-40	3
	9982-335-002	PLATE-CONTROLSMTG,COMPUTER(EC)	1
	9982-337-001	PLATE-READERMOUNTING(ECREADY)	1
	9454-569-021	Front Panel, Almond - EC	1
	9454-569-019	Front Panel, White - EC	1
	9454-569-020	PANEL-FRONT,STAINLESSSTEEL	1
	9506-144-002	WIRINGLABEL-SCHEMATIC	1
	9506-145-002	WIRINGLABEL-DIAGRAM	1
	9545-008-026	SCREW-HXWSHRHDUNCT,#10BX1/2	2
	9627-731-001	HARNES-KIT,DEXTER	1
	9797-006-003	CARDREADERASY-DEXTER,STANDARD	1
	9806-013-003	CABLEASY-4TWISTPR,20'SHLD/UNSH	1

EC Models (Intergrated EasyCard Ready Parts)

Key	Part Number	Description	Qty
	5192-286-015	Relay	1
	8220-001-198	Wireasy- Wht, 46 1/2"	1
	8220-001-199	Wireasy- Wht, 53 1/2"	1
	8220-001-200	Wireasy- Red, 53 1/2"	1
	8220-001-219	Wireasy- Blk, 56"	1
	8220-001-220	Wireasy- Red, 56"	1
	8220-001-227	Wireasy- Blk, 25 1/2"	1
	8220-001-230	Wireasy- Blk/Red, 8 1/2"	1
	8220-001-231	Wireasy- Blk/Blu	1
	8220-001-282	Wireasy- Red, 20"	1
	8220-001-290	Wireasy- Blk	1
	8220-001-412	Wireasy- Blu, 20"	1
	8220-001-462	Wireasy- Vio, 58"	2
	8220-001-478	Wireasy- Grn, 7"	1
	8220-001-479	Wireasy- Blu, 45"	1
	8220-001-480	Wireasy- Blk, 45"	1
	8220-001-530	Wireasy- Blk, 67"	1
	8220-001-531	Wireasy- Wht, 12"-4"	1
	8220-034-001	Wireasy-Brn,67"	1
	8220-034-002	Wireasy-Blu,461/2"	1
	8220-062-002	Wireasy- Blk, 11"	2
	8220-063-004	Wireasy- Blk, 48"	1
	8220-065-006	Wireasy- Blk/Red, 11"	1
	8220-065-007	Wireasy- Blk/Blu, 11"	1
	8220-068-002	Wireasy- Blk/Red, 7"	1
	8220-068-003	Wireasy- Blk/Blu, 5"	1
	8220-088-001	Wireasy- Wht, 8"	1
	8220-088-002	Wireasy- Blk, 5"	1
	8220-088-003	Wireasy- Red, 8"	2
	8220-097-001	Wireasy- JUmper, Brn	1
	8220-098-003	Wireasy- Jumper, Yel	1
	8220-101-001	Wireasy- Gry,251/2"	1
	8220-101-014	Wireasy- Vio,42"	1
	8220-101-016	Wireasy- Brn,411/2"	1
	8507-230-003	Instructions-Transform Connect	1
	8507-349-001	Instruction-Switches, Electactpt	1
	8514-003-012	Booklet-Owners 30# Dryers 9/07	1
	8615-104-040	Reducer-1/2x3/4	1
	8640-276-003	Nut-Wireconn, #73b, Org	10
	8640-424-002	Nut-Hexelasticstop, #4-40	3
	8711-008-002	Transformer-Control	1
	9000-043-001	Adapter-3/4usto3/4iso	1
	9021-015-002	Acceptor-CoiN, Electronic (109)	1
	9029-091-001	Bracket-Control Box	1
	9074-263-002	Cover-Ignition Control Box	1
	9183-030-001	Filter-Line,Emi	1
	9208-039-001	Guard-Drive	1
	9248-022-002	Hook-Stype	1
	9376-259-008	Motor-Dryer,A.O.Smith (30#)	1
	9381-009-005	Manifold Assembly-(2) Port	1
	9452-671-001	Plate-Bracket Extender	1
	9452-724-001	Plate-Mounting,Computer Control	1
	9453-169-009	Pulley-Drive, Machined	1
	9454-696-001	Panel-Shield, Motor, Lh	1

9454-697-001	Panel-Shield ,Motor, Rh	1
9471-011-002	Printed Circuit BOard Assembly	1
9506-204-001	Wiring Label- Schematic	1
9506-204-002	Wiring Label- Schematic	1
9506-205-001	Wiring Label-Diagram	1
9506-205-002	Wiring Label-Diagram	1
9539-461-007	Switch-Micro	1
9545-008-027	Screw-HxwsrhdsLtd, #10-32 Ttx 1/2	1
9627-651-003	Wiring Harness- Electronic Cntrl	1
9631-382-002	Wireasy-Gry, 45 1/2"	1
9631-403-005	Wireasy-High Voltage	1
9732-162-001	Kit-Honeywellvr 86 Valve Flange	2
9791-001-002	Adapter Assembly- Gas Inlet	1
9804-021-001	Shield Assembly- Motor	1
9807-080-001	Box Assembly- Control	1
9857-132-004	Control Assembly- Gas	1
9857-140-001	Control Assembly- Fenwal	1
9857-166-001	Control Assembly	1
9897-036-001	Terminal Block Assembly- Power	1
9982-334-002	Plate Assembly - Controls Mntng(Cmptr)	1

21CR Gas Heated Parts

Key	Part Number	Description	Qty
	5192-288-001	Relay	1
	8502-698-001	Label-Aussie warning	1
	8502-699-001	Label-Aust gas approval badge	1
	8502-725-001	Label-Instruct/Warn, Electr coin	1
	8502-730-001	Label-Warning, Elec coin acceptor	1
	8507-230-003	Instructions-Transform connect	1
	8507-298-001	Instructions-Aussie addendum	1
	8640-276-003	Nut-Wireconn,#73b,Org	13
	8711-008-002	Transformer-Control	1
	9021-015-002	Acceptor-Coin, Electronic(109)	1
	9074-263-001	Cover-Ignition control box	1
	9183-030-001	Filter-Line, Emi	1
	9208-039-001	Guard-Drive	1
	9248-022-002	Hook-Stype	1
	9376-259-008	Motor-Dryer,A.O.Smith(30#)	1
	9381-009-005	Manifold assembly-(2)Port	1
	9435-016-001	Overlay-Trim, Lwr serv door,30#	1
	9452-671-001	Plate-Bracket extender	1
	9452-724-001	Plate-Mounting, Computer control	1
	9453-169-009	Pulley-Drive, Machined	1
	9454-644-001	Panel-Control box, Top	2
	9454-696-001	Panel-Shield, Motor, Lh	1
	9454-697-001	Panel-Shield, Motor, Rh	1
	9456-041-006	Plug-Plastic,7/8"	7
	9471-011-002	Printed circuit board assembly	1
	9506-074-002	Wiringlabel-Schematic	1
	9506-075-002	Wiringlabel-Diagram	1
	9578-087-001	Trim-Door, Lower service	1
	9627-651-003	Wiring harness-Electronic control	1
	9631-381-018	Wire assembly-Red,7"	1
	9631-382-002	Wire assembly-Gry,45 1/2"	1
	9732-162-001	Kit-Honey wellvr 86 valve flange	2
	9804-021-001	Shield assembly-Motor	1
	9807-080-001	Box asy- Control	1
	9857-129-001	Controls asy-Ignition, Johnson	1
	9857-131-001	Control asy	1
	9857-132-004	Control assembly-Gas	1
	9982-334-001	Plateasy-Controls mntng(Cmptr)	1
	9982-334-002	Plateasy-Controls mntng(Cmptr)	1
	8220-001-198	Wire assembly-Wht,46 1/2"	1
	8220-001-199	Wire assembly-Wht,53 1/2"	1
	8220-001-200	Wire assembly-Red,53 1/2"	1
	8220-001-219	Wire assembly-Blk,56"	1
	8220-001-220	Wire assembly-Red,56"	1
	8220-001-221	Wire assembly-Blk,45"	1
	8220-001-222	Wire assembly-Blu,45"	1
	8220-001-227	Wire assembly-Blk,25 1/2"	1
	8220-001-282	Wire assembly-Red,20"	1
	8220-001-332	Wire assembly-Blk	1
	8220-001-333	Wire assembly-Wht	1
	8220-001-411	Wire assembly-Red,9"	2
	8220-001-412	Wire assembly-Blu,20"	1
	8220-001-530	Wire assembly-Blk,67"	1
	8220-034-001	Wire assembly-Brn,67"	1
	8220-034-002	Wire assembly-Blu,46 1/2"	1
	8220-057-020	Wire assembly-Blu,54"	2
	8220-062-002	Wire assembly-Blk,11"	2

8220-062-024	Wire assembly-Wht,19"	1
8220-063-004	Wire assembly-Blk,48"	1
8220-064-025	Wire assembly-Wht,9"	2
8220-088-013	Wire assembly-Blk,6"	1
8220-090-002	Wire assembly-Jumper,Brn	1
8220-098-001	Wire assembly-Jumper,Yel	1
8220-100-002	Wire assembly-Jumper	1
8220-101-001	Wire assembly-Gry,25 1/2"	1
8220-101-003	Wire assembly-Blu,41 1/2"	1
8220-101-016	Wire assembly-Brn,41 1/2"	1
8220-107-001	Wire assembly-Jumper,Wht	2

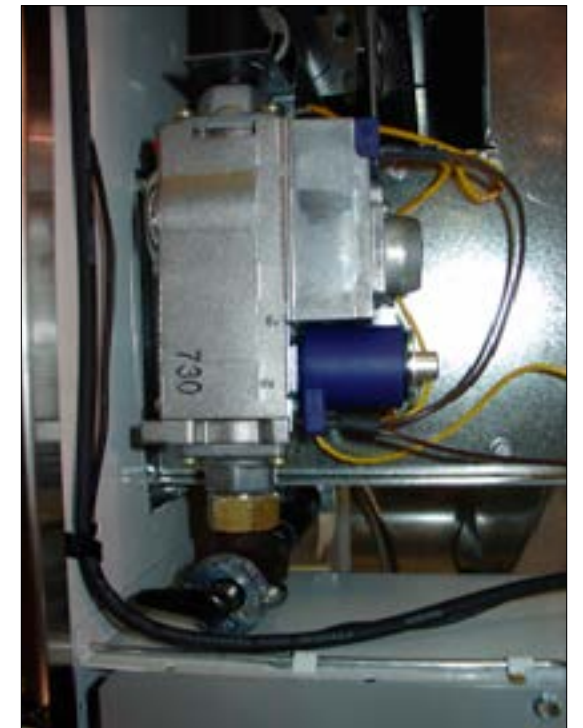
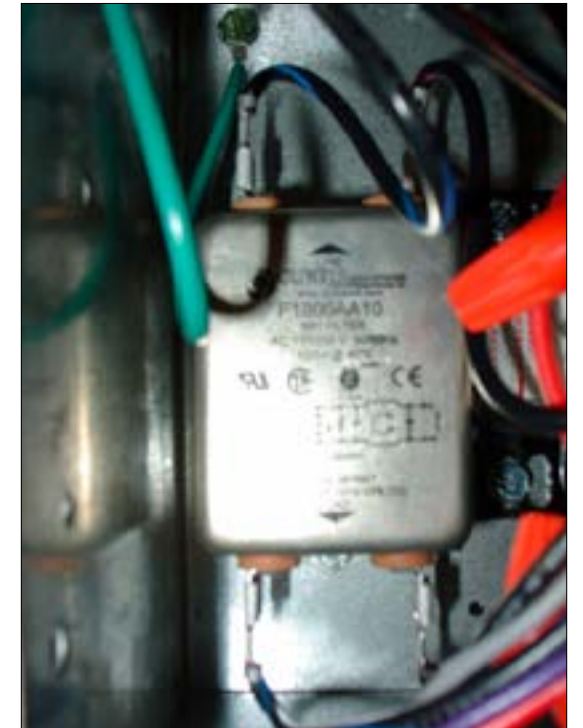

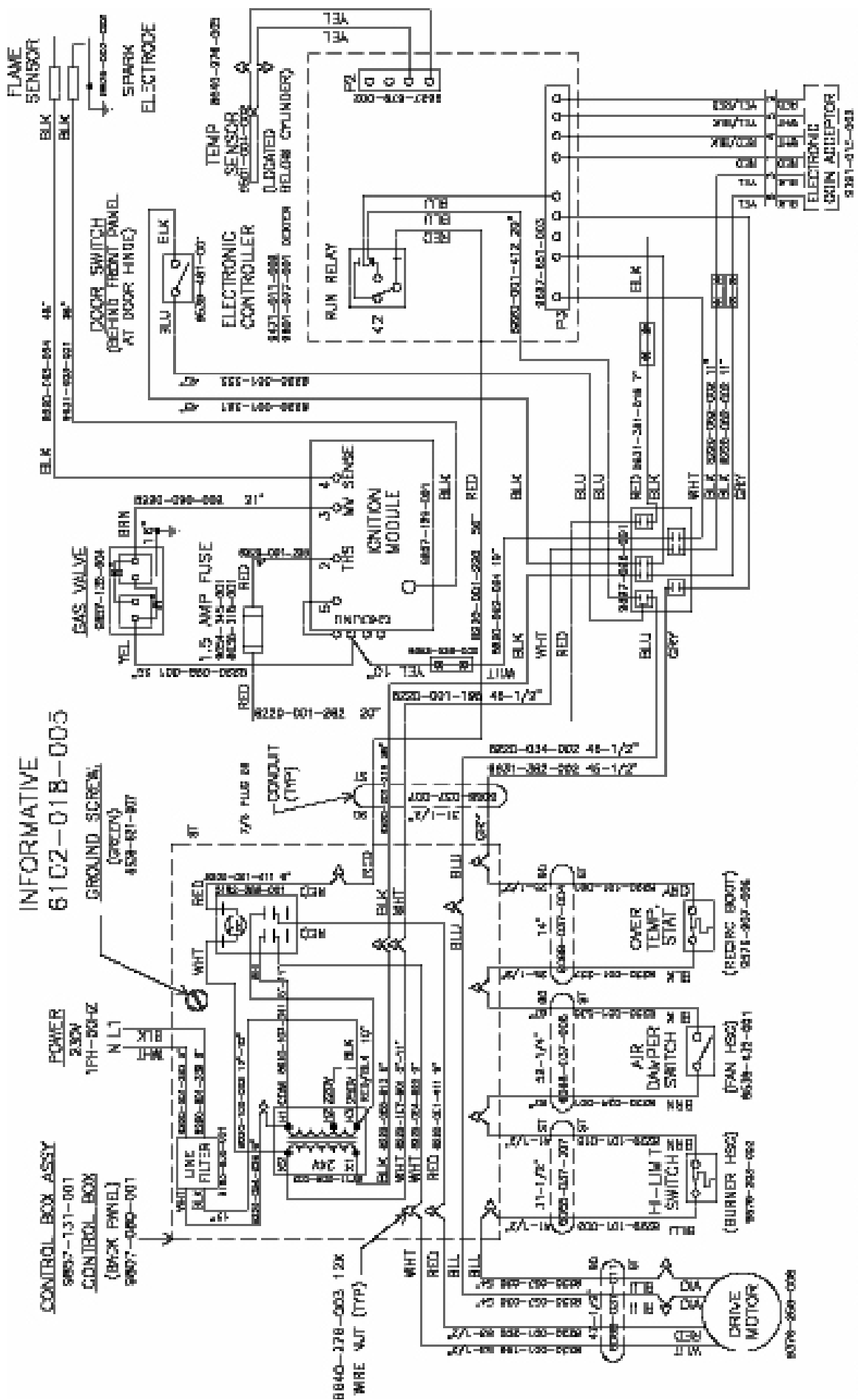

WIRING DIAGRAM

DCT_30KC_21CR_50HZ_AL

9506-075-0C2

16FE Electric Heated Parts List

Key	Part Number	Description	Qty
	5192-294-001	Relay-125 amp (Resistive) Contact.....	1
	5198-213-004	Circuit breaker-3 pole.....	2
	8220-057-004	Wire assembly-Brn,30".....	1
	8220-057-007	Wire assembly-Wht/Blk,45".....	1
	8220-057-008	Wire assembly-Blk,45".....	1
	8220-057-014	Wire assembly-Blk,8".....	3
	8220-057-015	Wire assembly-Blk,8".....	6
	8220-057-019	Wire assembly-Wht,8".....	1
	8220-061-008	Wire assembly-Blk,36".....	4
	8220-061-010	Wire assembly-Blk,48".....	2
	8220-064-021	Wire assembly-Blk/Wht,90".....	1
	8220-095-025	Wire assembly-Red,31".....	1
	8220-101-002	Wire assembly-Blk,64".....	1
	8220-101-005	Wire assembly-Gry,64".....	1
	8220-101-015	Wire assembly-Brn,30".....	1
	8502-614-004	Label-Warning,High voltage.....	1
	8502-639-001	Label-Warning.....	1
	8502-658-001	Label-Warning,Fire hazard.....	1
	8502-702-001	Label-Warn,Fire hazard (French).....	1
	8502-708-001	Label-Exhaust warning.....	1
	8502-711-001	Label-Warning for 208v.....	1
	8514-106-001	Booklet-Owners, 30# Htd Dryer.....	1
	8639-621-007	Screw-Hx wshr hd,#10-32x1/2,Gm.....	1
	8640-276-003	Nut-Wire conn,#73b,Org.....	1
	8652-134-002	Terminal-Lug, Solderless.....	1
	8653-068-004	Connector-Conduit, 90 degree.....	5
	8653-068-006	Connector-Conduit, 3/8", 45.....	1
	9029-127-001	Bracket-Guard mounting.....	1
	9058-025-001	Bottom-Box, Control.....	1
	9074-288-001	Cover-Plate, Heater.....	1
	9074-289-001	Cover-Box, Control.....	1
	9074-290-001	Cover-Housing, Overtemp thermo.....	1
	9109-108-001	Duct-Thermostat,Over temp.....	1
	9142-039-001	Elbow-90 degree ajd,8".....	2
	9208-053-001	Guard-Front,Cabinet cover.....	1
	9208-058-001	Guard-Rear,Right hand (Cover).....	1
	9208-059-001	Guard-Rear,Left hand (Cover).....	1
	9241-187-001	Housing-Thermostat, Overtemp.....	1
	9295-004-001	Jumper-Formed.....	2
	9295-005-001	Jumper-Straight.....	4
	9377-003-001	Varistor-Coil suppressor.....	1
	9488-010-001	Rail-Din.....	0.396
	9488-010-003	Rail-Din, 43/4".....	1
	9506-176-002	Wiring label-Schematic.....	1
	9506-177-002	Wiring label-Diagram.....	1
	9548-282-001	Support-Wire.....	2
	9870-088-001	Heater-Electric elem, 15kw, 208v.....	2
	9897-037-001	Block-Power, 3 pole.....	1
	9897-038-001	Block-Power, 1 pole.....	1

66 FW Electric Heated Parts List

Key	Part Number	Description	Qty
	5192-285-004	Relay	1
	5192-288-001	Relay	1
	5192-290-002	Relay-Heaters,40amp(240vac)	1
	5198-215-002	Circuitbreaker-3pole,415v	1
	8220-001-199	Wireasy-Wht,531/2"	1
	8220-001-200	Wireasy-Red,531/2"	1
	8220-001-221	Wireasy-Blk,45"	1
	8220-001-222	Wireasy-Blu,45"	1
	8220-001-290	Wireasy-Blk	1
	8220-001-411	Wireasy-Red,9"	2
	8220-001-412	Wireasy-Blu,20"	1
	8220-001-530	Wireasy-Blk,67"	1
	8220-034-001	Wireasy-Brn,67"	1
	8220-034-002	Wireasy-Blu,461/2"	1
	8220-057-004	Wireasy-Brn,30"	1
	8220-057-007	Wireasy-Wht/Blk,45"	1
	8220-057-008	Wireasy-Blk,45"	1
	8220-057-011	Wireasy-Vio,32"	1
	8220-057-015	Wireasy-Blk,8"	3
	8220-057-019	Wireasy-Wht,8"	1
	8220-057-020	Wireasy-Blu,54"	2
	8220-057-030	Wireasy-Blk,17"	3
	8220-061-008	Wireasy-Blk,36"	3
	8220-064-025	Wireasy-Wht,9"	1
	8220-064-051	Wireasy-Red/Blk,62"	1
	8220-078-008	Wireasy-Blk,9"	2
	8220-078-011	Wireasy-Wht,45"	1
	8220-078-012	Wireasy-Red,45"	1
	8220-088-013	Wireasy-Blk,6"	1
	8220-101-002	Wireasy-Blk,64"	1
	8220-101-005	Wireasy-Gry,64"	1
	8220-101-014	Wireasy-Vio,42"	1
	8220-101-015	Wireasy-Brn,30"	1
	8220-107-001	Wireasy-Jumper,Wht	2
	8220-107-002	Wireasy-Jumper,Blk	1
	8502-614-004	Label-Warning,Highvoltage	1
	8502-639-001	Label-Warning	1
	8502-658-001	Label-Warning,Firehazard	1
	8502-698-001	Label-Aussiewarning	1
	8502-708-001	Label-Exhaustwarning	1
	8507-230-003	Instructions-Transformconnect	1
	8507-298-001	Instructions-Aussieaddendum	1
	8636-018-004	Fuse-2.5a	1
	8652-134-002	Terminal-Lug,Solderless	1
	8653-039-000	Connector-WiRe,Inline,1/4"	1
	8711-008-002	Transformer-Control	1
	9021-002-015	Acceptor-Coin,Complete	1
	9029-127-001	Bracket-Guardmounting	1
	9058-025-001	Bottom-Box,Control	1
	9074-263-001	Cover-Ignitioncontrolbox	1
	9074-288-001	Cover-Plate,Heater	1
	9074-289-001	Cover-Box,Control	1
	9074-290-001	Cover-Housing,Overtmpthermo	1
	9109-108-001	Duct-Thermostat,Overtmp	1
	9142-039-001	Elbow-90 degree, 8"	2

9208-039-001	Guard-Drive	1
9208-053-001	Guard-Front,Cabinetcover	1
9208-058-001	Guard-Rear,Righthand(Cover)	1
9208-059-001	Guard-Rear,Lefthand(Cover)	1
9210-117-001	Gusset-Box,Control	1
9241-187-001	Housing-Thermostat,Overtmp	1
9248-022-002	Hook-Style	1
9295-006-001	Jumper-Straight,3hole	1
9376-259-008	Motor-Dryer,A.O.Smith(30#)	1
9377-003-002	Varistor-Coilsuppressor	1
9435-016-001	Overlay-Trim,Lwrservdoor,30#	1
9452-668-003	Plate-Controls,Mounting(Cmptr)	1
9452-741-001	Plate-Replacement,Heater	1
9453-169-001	Pulley-Drive-Casting-Manual	1
9453-169-009	Pulley-Drive,Machined	1
9454-644-001	Panel-ControlbOx,Top	2
9454-696-001	Panel-Shield,Motor,Lh	1
9454-697-001	Panel-Shield,Motor,Rh	1
9456-041-006	Plug-Plastic,7/8"	9
9471-011-002	Printedcircuitboardassembly	1
9488-010-001	Rail-Din	0.396
9488-010-003	Rail-Din,43/4"	1
9506-206-001	Wiringlabel-Schematic	1
9506-206-002	Wiringlabel-Schematic	1
9506-207-001	Wiringlabel-Diagram	1
9506-207-002	Wiringlabel-Diagram	1
9544-041-002	Strap-Beadedtie	1
9548-282-001	Support-Wire	1
9578-087-001	Trim-Door,Lowervice	1
9804-021-001	Shieldassembly-Motor	1
9857-163-001	Controlasy	1
9870-088-002	Heater-Electricelem,15kw,240v	1
9897-037-001	Block-Power,3pole	1
9897-038-001	Block-Power,1pole	1
9982-305-005	Plateasy-Controls,Mntg(Cmptr)	1
9982-305-006	Plateasy-Controls,Mntg(Cmptr)	1