



***DEXTER***<sup>®</sup>  
***LAUNDRY***

**USE THE BLUE TABS LOCATED ON THE  
RIGHT AND LEFT SIDES OF THE FOLLOWING  
DOCUMENT TO ADVANCE TO EACH SECTION.**

## Kits, Assemblies, & Common Parts

Description	T 20x2
LP to Natural Conversion Kit for White Rodgers	9732-142-004
Kit - A to C series Conversion, Black, 24v	9732-307-004
Temperature Probe	9501-006-002
Controls	9857-187-003
Ignition Control Box	9857-251-001
Electrode Assembly, Ignition	9875-002-003
Thermostat, Hi-Limit	9576-203-002
Thermostat, Overtemp	9576-207-006
Fuseholderassembly	9200-001-002
Fuse-1.5a,fast,1/4x1-1/4	8636-018-001
Fuse-2.5a,fast,1/4x1-1/4	8636-018-004
Motor Run Relay	5192-299-002
Transformer, Ignition	8711-013-001
Lint Screen Assembly (No Front)	9805-036-002
Air Flow Switch	9536-461-009
Motor Belt	9040-076-012
Tumbler Belt	9040-073-013
Tension Arm Complete	9861-022-001
Spider/Trunnion	9568-018-001
Door Handle	9244-092-001



## Section 6: Parts Data

## Dryer Cabinet Group

	Description	T-20X2	QTY
1	Panel Assy., Front- Upper (SS)	9989-610-004	1
*	Insulation Front Panel, half moon (top)	9277-064-001	1
*	Insulation Front Panel, half moon (bottom)	9277-064-002	1
2	Screw, FLHDCR, 10B x- 1 3/4	9545-008-014	4
3	Washer, Finish, #10	8641-585-001	4
*	Nut, Spring	8640-399-001	4
*	Hinge ,Backup Plate	9982-392-001	1
*	Screw, Countersink, 10-32X 1/2	9545-012-003	2
4	Strap, Hinge (SS/Black)	9544-074-002	2
*	Screw, Hinge to Panel	9545-012-028	4
*	Door Assy., Loading Complete-Chrome/BLK/SS	9960-315-002	1
5	Door Assy., Loading-Chrome(ring only)	9960-314-003	2
5	Door Assy, Loading-Black (ring only) (after serial D1.22290.0005)	9960-314-004	2
6	Plate Assy., Hinge (SS)	9982-393-001	1
*	Screw, Hinge to Door	9545-012-015	4
*	Nut, Hinge to Door	8640-413-002	4
*	Cover, Hinge Plate	9074-377-002	1
*	Screw, Phillips-10B x 3/8	9545-008-010	2
7	Glass, Door	9212-002-005	1
8	Gasket, Glass Black	9206-413-003	1
*	Support, Door Glass	9548-117-000	1
*	Tool Install Dryer Door Gasket	8545-064-001	1
9	Gasket, Outer Rim Black	9206-420-006	1
10	Handle, Loading Door	9244-092-001	1
*	Screw, Handle 1/4-20 x 3/8	9545-018-017	2
11	Stud, Door Catch, 3/4	9531-033-002	1
12	Nut, Hex	8640-413-001	1
13	Nut, Acorn	8640-413-003	1
14	Catch, Loading Door	9086-015-002	1
15	Pop Rivet for mtg. catch	8638-190-009	2
16	Screw, Door to Hinge Strap (Special Black Type)	9545-052-001	1
17	Washer, Fiber	8641-436-003	1
*	Cabinet Touch Up Paint (White)	9472-001-013	1

## Cabinet Group

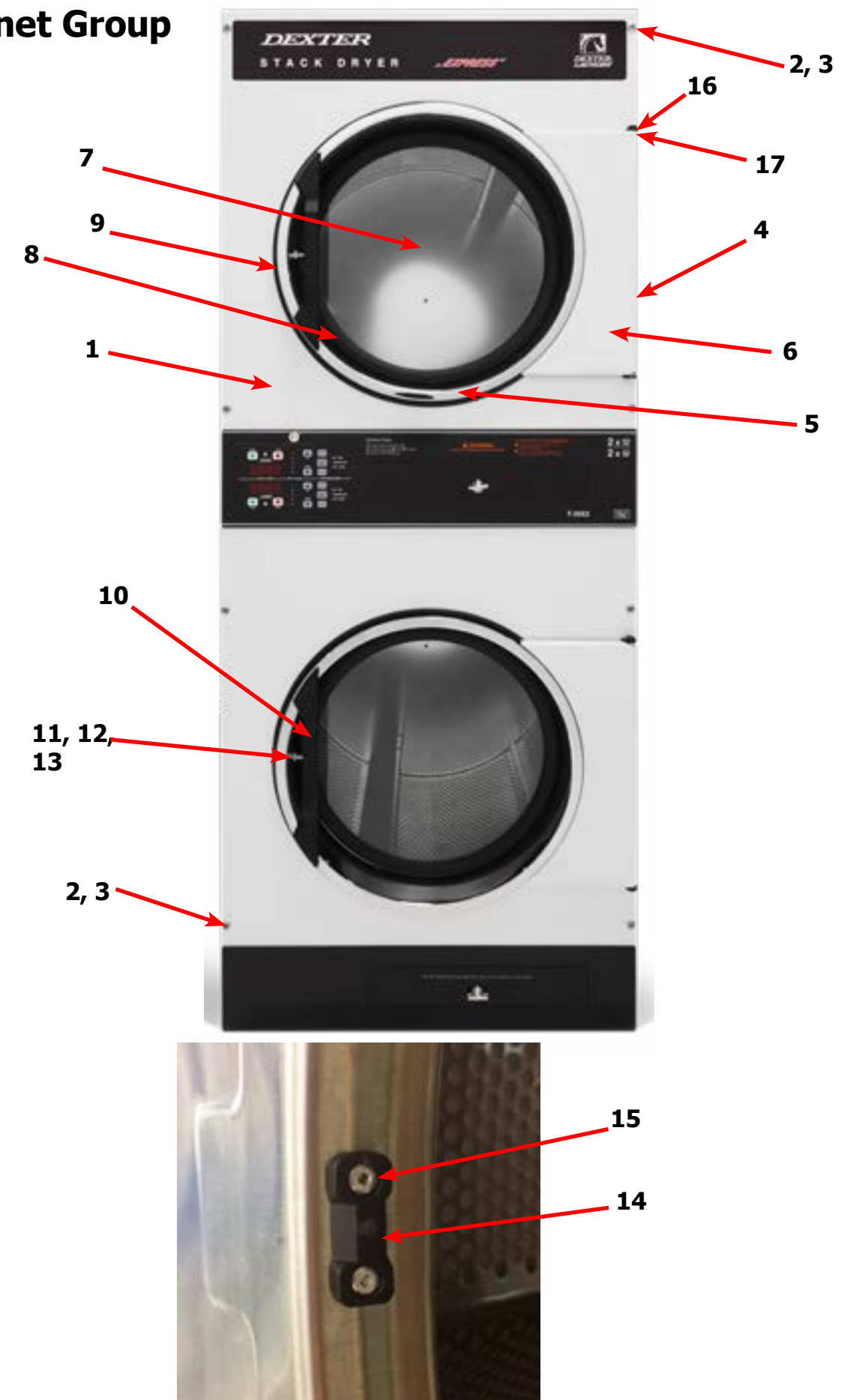

## Dryer Cabinet Group

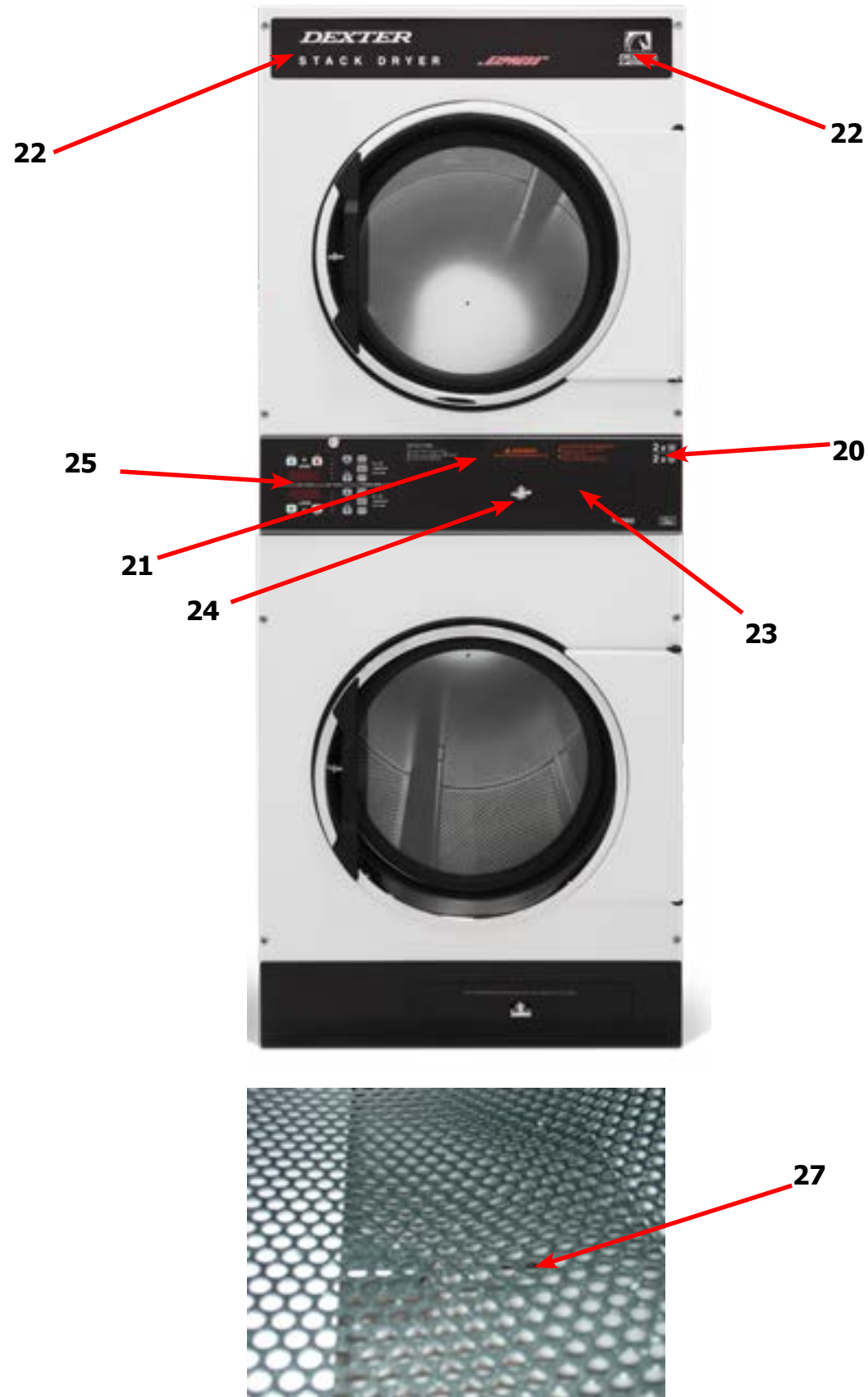

## Cabinet Group Continued

Key	Description	T-20X2	QTY
20	Escutcheon	9994-044-001	1
21	Trim, Overlay-Upper Black	9435-059-001	1
*	Screw, #4-40 x 3/16	9545-020-009	12
22	Nameplate Stack Dryer Express Black	9412-251-001	1
*	Lint Drawer Assembly Black	9866-008-005	1
*	Drawer, Front PTD	9974-016-002	1
*	Washer, Flat, #10	8641-581-006	2
*	Washer, Curved-Spring	8641-569-004	2
*	Nut, 10-32	8640-413-007	2
23	Overlay Trim, Lint Drwr-Black	9435-053-003	1
*	Felt Seal (back of lint screen assembly)	9532-074-004	1
*	Lint Screen Assembly ONLY (no front)	9805-036-002	1
*	Replaceable Lint Screen Only	9555-057-011	1
24	Lock-Door Service Thumb Turn	8650-026-002	1
*	Cam, Lock	9095-044-001	1
*	Lint Screen Strap Hold Down Screws 10Bx 1/4	9545-008-001	32
25	Controls Assy, 24VAC, Black	9857-187-003	1
*	Harness, Electronic Control	9627-885-003	1
*	Control Board	9471-017-001	1
*	Harness, Heat Sensor	9627-886-001	1
*	Wire Nut Connector Grey	8640-276-002	2
*	Membrane Switch	9801-105-001	1
27	Sensor Temp/Bracket Control	9501-006-002	2
*	Cover, Cabinet (Top)	9074-374-001	1
*	Insulation Cabinet Cover	9277-041-028	1
*	Screw-hxwshrundrcuthd,10abx3/8	9545-008-024	14
*	Stack Dryer Trunion Puller	9732-243-001	1
*	Leg, Leveling 1/2"	8544-006-001	4
*	Leveling Leg Wrench	8545-061-002	1



	Description	T-20X2	QTY
*	Switch Assy, Air Flow	9801-095-001	1
1	Switch, Air Flow	9539-461-009	1
2	Bracket, Switch- Air Flow	9029-174-001	1
3	Actuator, Switch	9008-007-001	1
4	Pin, Cotter	9451-169-002	1
5	Screw 4-40 x 5/8"	9545-020-001	2
*	Nut, Special Twin .#4-40	8640-401-001	1
*	Shield, Switch	9550-169-003	1
*	Screw 10 Bx 1/4"	9545-008-001	3
6	Motor, Drive	9376-332-001	2
*	Run Capacitor	5191-108-004	2
*	Start Capacitor	5191-109-004	2
*	Pulley-motor,60hz	9453-185-001	1
*	Screw-set,5/16-18x1/2	9545-028-013	1
*	Impeller (W/Setscrew)	9278-045-001	1
7	Plate, Motor Mtg	9982-390-002	1
*	Bolt 3/8" - 16 x 3/4"	9545-029-008	1
*	Lockwash Spring 3/8	8641-582-003	1
8	Screw, Motor to Plate Screw-hxflgwhzlk,5/16-18x5/8	9545-014-004	4
*	Nut-hextwinwhzlk,5/16-18	8640-400-003	4
9	Nut 1/4x20 Motor Plate to Cabinet	8640-414-007	7
10	Clamp-cable,3/4	8654-125-004	2
*	Screw-hxhdsltdmach,12abx1/2	9545-048-001	2
11	SupportAssy, Intermed. Pulley	9991-053-002	1
12	Bolt, Rd Hd 3/8-16 x 1 1/4	9545-029-010	3
13	Bolt, 3/8-16 x 1 1/2	9545-029-012	1
12	Nut Flange Wizioc 3/8" - 16	8640-415-004	3
*	Washer, Flat	8641-581-035	1
14	Arm Assy-Tension, Complete	9861-022-001	1
*	Washer, Flat	8641-581-035	1

## Rear View Photos

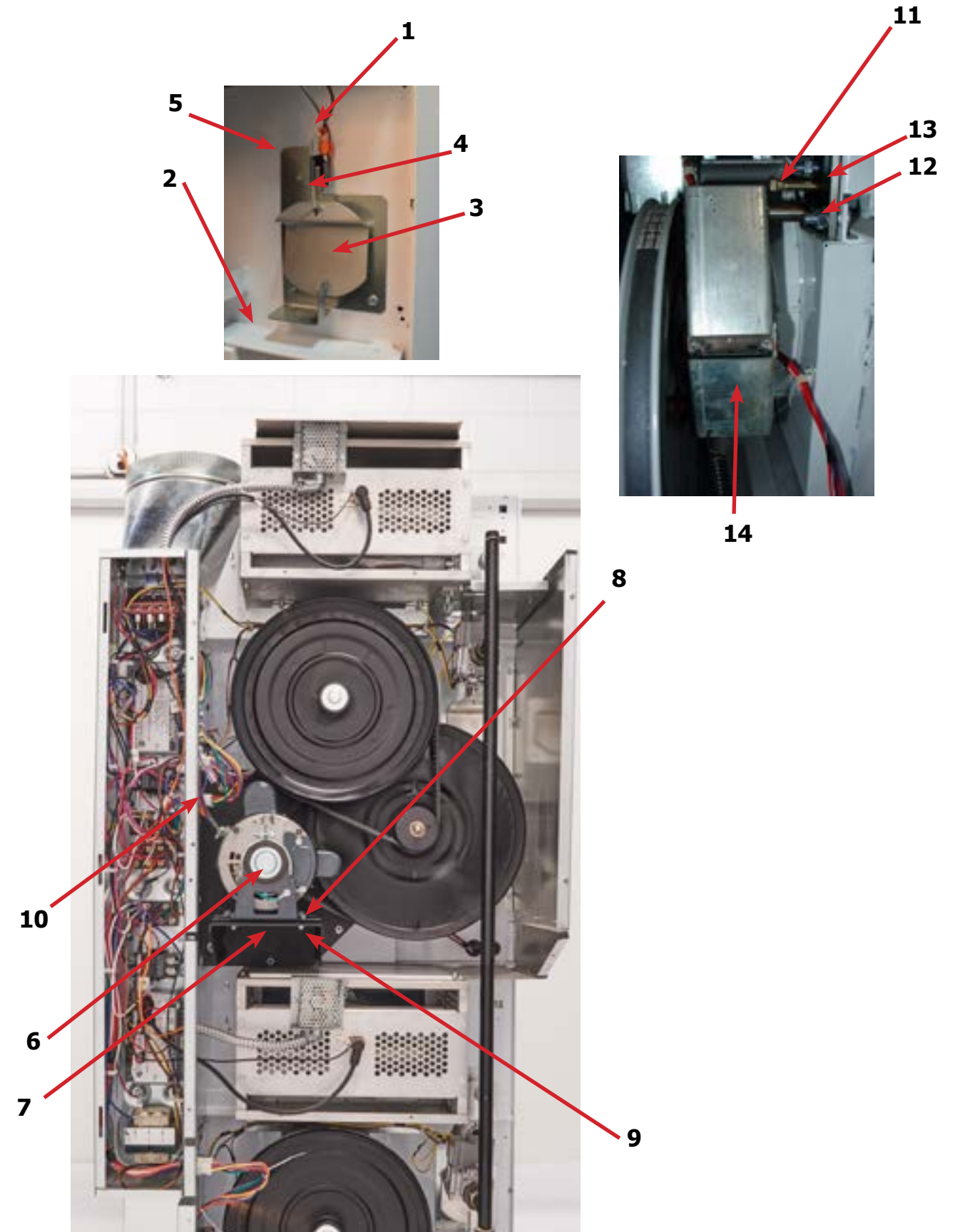

	Description	T-20X2	QTY
14	Arm Assy-Tension, Complete	9861-022-001	1
*	Washer, Flat	8641-581-035	1
15	Ring-Retaining	9487-200-003	1
16	Pulley Assy, Intermediate with bronze flange bearing	9908-053-003	1
*	Bearing - Bronze Flange	9036-145-002	1
*	Spacer-Shaft (See Tumbler Group for Expanded View)	9538-164-001	1
*	Tolerance Ring	9487-234-005	1
17	Pulley, Driven	9908-052-002	1
18	Washer -Flat	8641-581-026	1
18	LockWasher - IntTooth, 1/2"	8641-582-016	1
18	Screw, 1/2-13x1 1/4	9545-017-009	1
19	Belt, Drive- Motor	9040-076-012	1
20	Belt, Drive- Tumbler	9040-073-013	1
21	Spring, Tension	9534-319-002	1
22	Chain, Tension	9099-012-011	1
23	Hook, Tension	9248-022-002	1
*	Damper Inside Duct Exhaust	9125-009-001	1
24	Pin, Damper Hinge	9451-146-007	1
*	Box-duct.lower	9041-113-001	1
*	Nut, Spring	8520-141-000	1
*	Screw #10B x 1/2	9545-008-026	3
*	Cover Duct Upper	9074-382-001	1
*	Base Duct	9047-121-001	1
*	Screw 10ABx 3/8"	9545-008-024	40
26	Impeller, W/Set Screws	9278-045-001	1
27	Pulley, Motor	9453-185-001	1
28	Bracket for Wire Harness Under Burner Housing	9029-305-001	1

## Rear View Photos

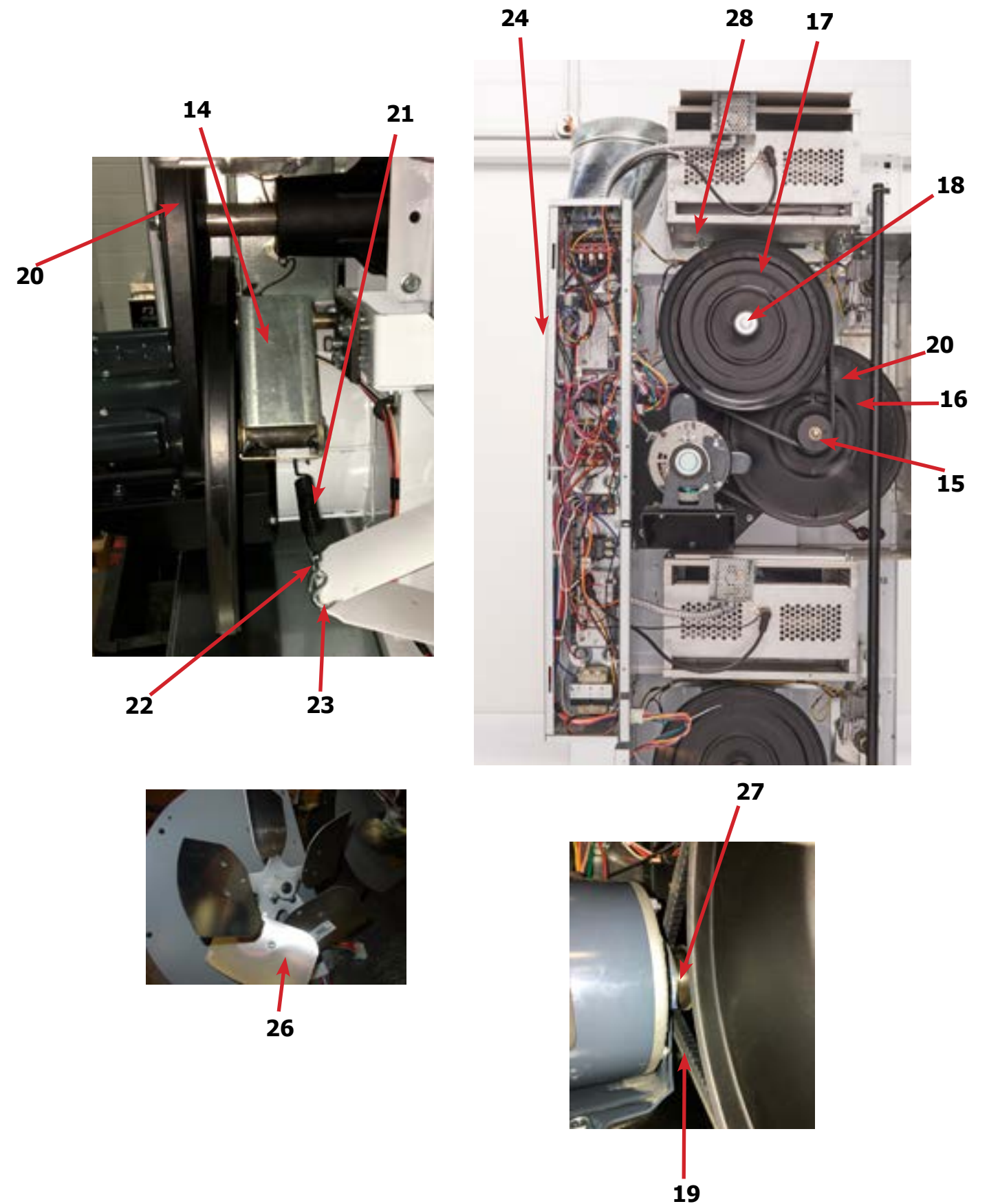

## Dryer Back Panels and Guards

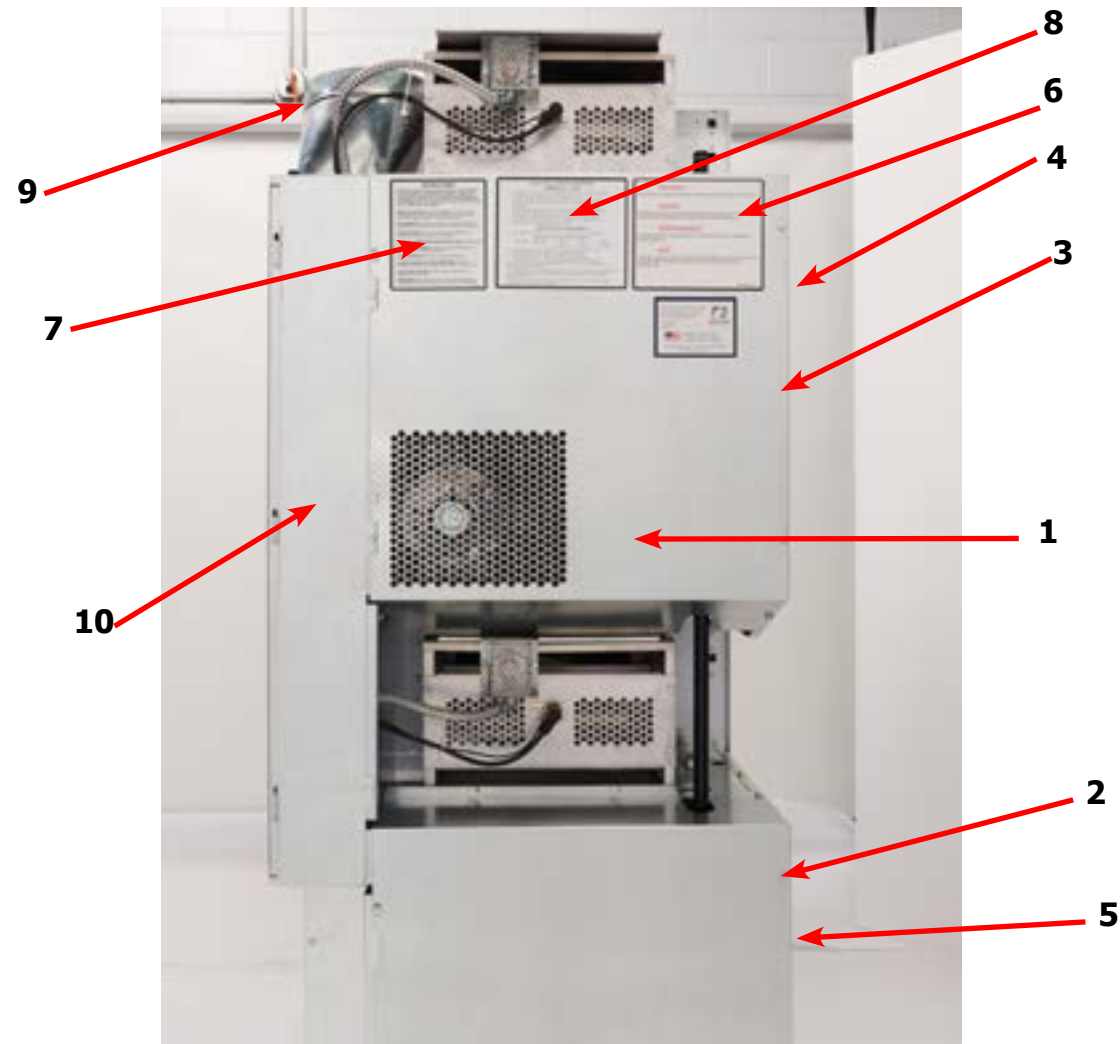

Key	Description	Part Number	Qty
1	Guard, Drive	9208-144-001	1
2	Screw, 10AB x 3/8	9545-008-024	20
3	Panel, Drive Guard,	9208-131-001	1
4	Guard-Small, upper	9208-134-001	1
5	Guard-side,lower	9208-132-001	1
6	Warning, Label	8502-763-001	1
7	Label, Instructions	8502-645-001	1
8	Lighting and Clearance, Label	8527-112-001	1
9	Duct, Transition	9109-127-001	1
10	Door, Cover-Control Box	9108-146-001	1
*	Cabinet, Cover	9074-374-001	1
*	Insulation	9277-041-028	1
*	Screw, 10AB x 3/8	9545-008-024	10
*	Wiring Diagram & Schematic	9506-838-001	1
*	8" Slide Open Clean Out Duct (Optional)	9973-034-001	1

## Air Flow Switch Assembly

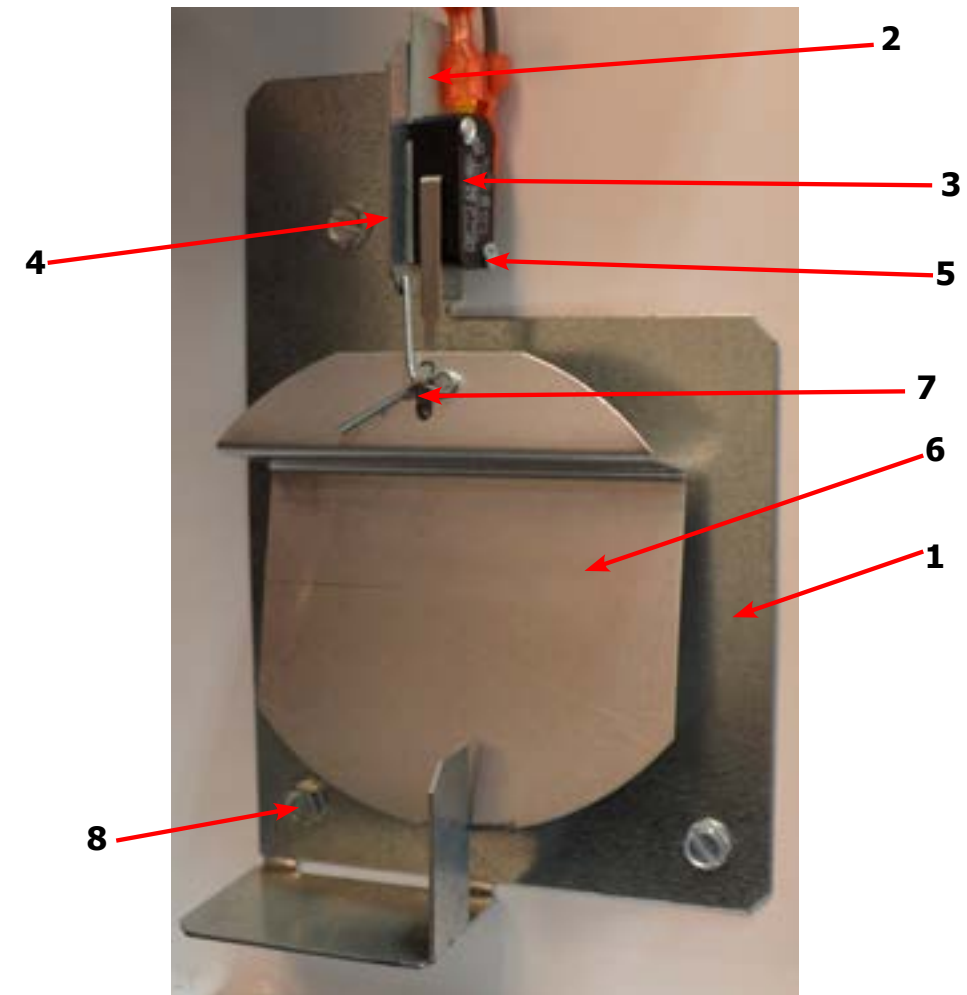

Key	Description	T-20X2	QTY
*	Air Flow switch Assy	9801-095-001	2
1	Bracket-Airflow switch	9029-174-001	2
2	Shield-Switch	9550-169-003	2
3	Switch-Micro	9539-461-009	2
4	Nut-Twin, 4-40	8640-401-001	2
5	Screw-.625, 4-40	9545-020-001	2
6	Actuator-Air Flow Switch	9008-007-001	2
7	Pin-Cotter, .09375x.75	9451-169-002	2
8	Screw, 10BX x 1/4	9545-008-001	3
*	Harness Assembly, Overtemp/Airflow	9627-861-002	1



## Bearing Housing Group

Key	Description	T-20X2	QTY
	Bearing Housing Complete Assy (Includes bearings & Spacer)	9803-160-003	1
1	Housing, Bearing	9241-161-002	1
*	Spacer, Bearing	9538-139-002	1
2	Bearing, Ball, Front & Rear	9036-130-001	2
3	Screw-Wizlock, 3/8-24x3/4	9545-049-002	4
4	Nut, 5/16-18	8640-400-002	4
5	Screw, 3/8-24x1	9545-049-001	2
6	Nut, 3/8-24	8640-415-002	2

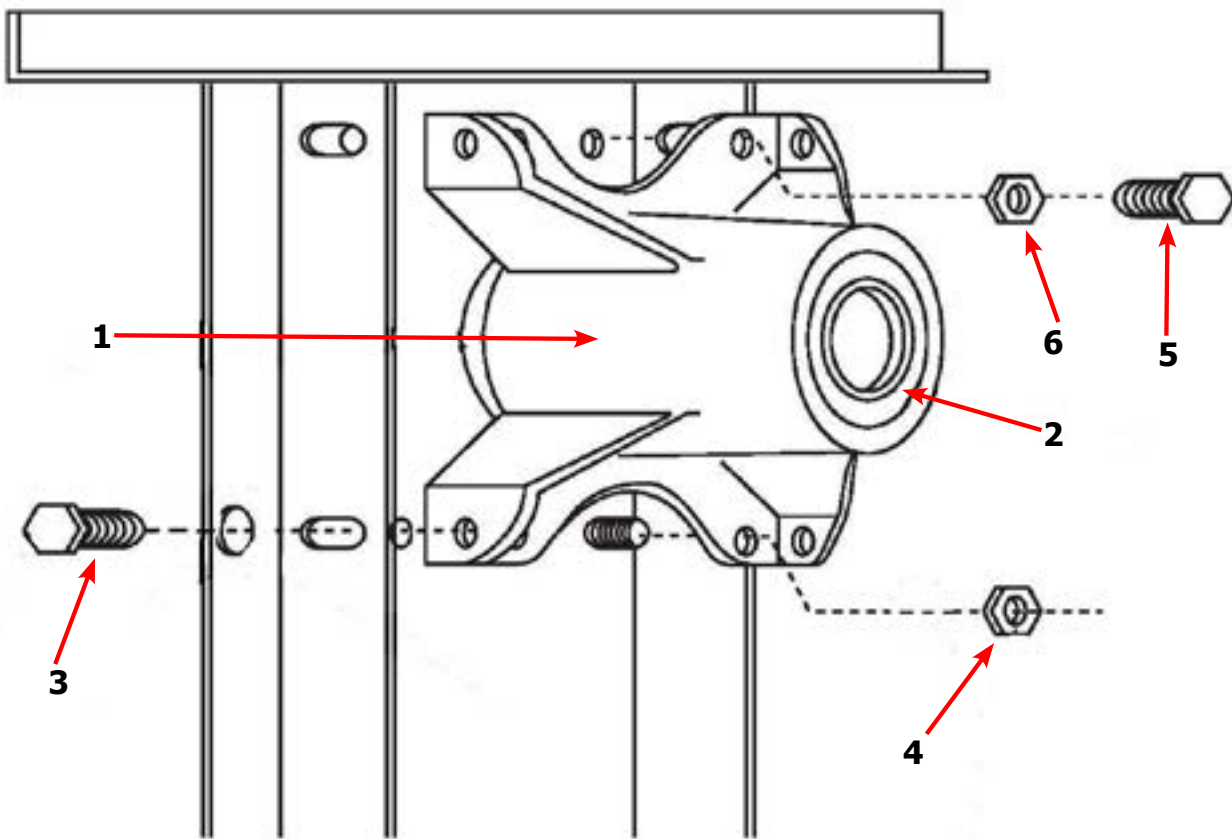

## Tumbler Group

Key	Description	T-20X2	QTY
*	Tumbler Assy Complete W/Spider (GALV)	9848-156-001	1
1	Tumbler Assy (Galvanized)	9848-155-001	1
2	Rod, Tumbler	9497-019-004	3
3	Washer, Special	8641-554-001	3
4	Shim	9552-013-003	AR
5	Spider Assy	9568-018-001	1
6	Nut, Wiz Lock	8640-415-004	3
7	Spacer-Shaft	9538-164-001	1
8	Tolerance Ring	9487-234-005	1
9	Pulley, Driven	9908-052-002	1
10	Washer -Flat 1/2	8641-581-026	1
11	LockWasher - IntTooth, 1/2	8641-582-016	1
12	Screw, 1/2-13x1 1/4	9545-017-009	1
*	Belt, Drive	9040-073-013	1
*	Belt, Driven (Motor)	9040-076-012	1

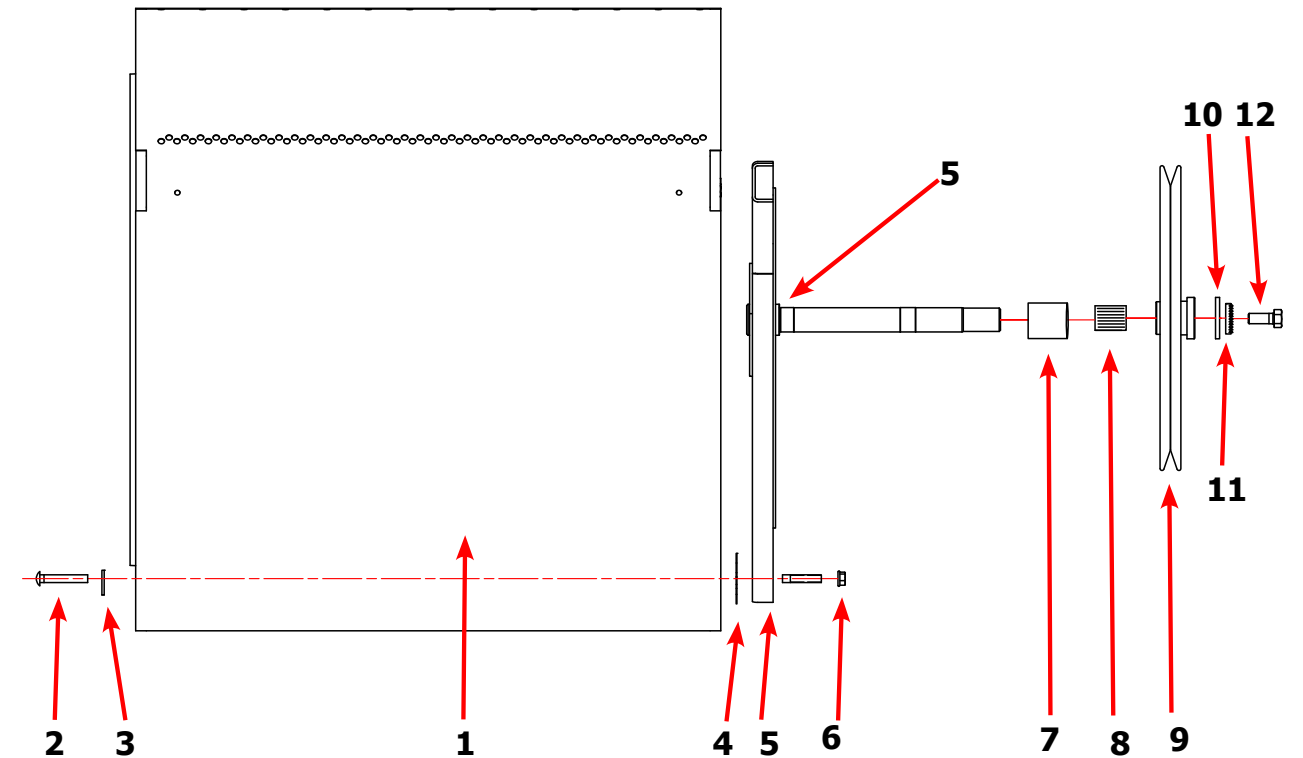



# Dryer Burner Housing Group

Key	Description	T-20X2	QTY
*	Housing Assembly, Burner (All sheet metal parts not listed)	9803-221-001	1
1	Panel, Back Burner Housing	9454-949-001	1
2	Screw, 10B X 1/4"	9545-008-001	4
3	Angle, Burner Support	9003-220-001	1
*	Screw, 10AB x 3/8"	9545-008-024	2
4	Burner, Main	9048-023-001	2
*	Screw 10AB x 3/8"	9545-008-006	2
5	Electrode-ignition	9875-002-003	1
6	Screw, Electrode Mtg 8B x 1/4"	9545-045-001	2
7	Valve, Gas Shut Off (Optional)	9379-196-001	1
8	Pipe Assembly	9838-018-004	1
*	Gas Pipe Assembly Replacement Kit	9732-360-001	1
8	Gas Pipe Assembly (After Serial)	9838-023-001	1
*	Fitting - 1/2 NPT Union Adapter	8615-120-001	1
11	Control Assy, Gas (Honeywell)	9857-134-001	1
11	Control Assy, Gas (White Rodgers)	9857-192-001	1
*	Wireasy-yel,47/8"	8220-001-466	1
12	Manifold, Assy	9381-012-001	1
*	Orifice, Burner-Natural #40	9425-069-030	2
*	Orifice, Burner-LP #54	9425-069-031	2
13	Bracket, Manifold	9029-306-001	2
14	Pipe Plug in end of Burner Manifold	9456-054-001	1
*	Screw, 10AB x 3/8"	9545-008-006	2
15	Bracket, High Limit Thermostat	9029-192-001	1
16	Thermostat, Hi-Limit	9576-203-002	1
*	Spacer, Hi-Limit	9538-142-001	2
*	Screw 8B x 3/4"	9545-045-007	2
17	Cover, Hi-Limit Stat	9074-329-001	1
*	Screw, 10AB x 3/8"	9545-008-006	2
18	Thermostat, Safety Shutoff	9576-207-006	1
19	Screw, 10AB x 3/8"	9545-008-006	2
*	Control, Ignition Fenwall (3 trybox)	9857-251-001	1
*	Kit, LP Conversion (Honeywell)	9732-102-038	1
*	Kit, LP Conversion (White Rodgers)	9732-102-043	1

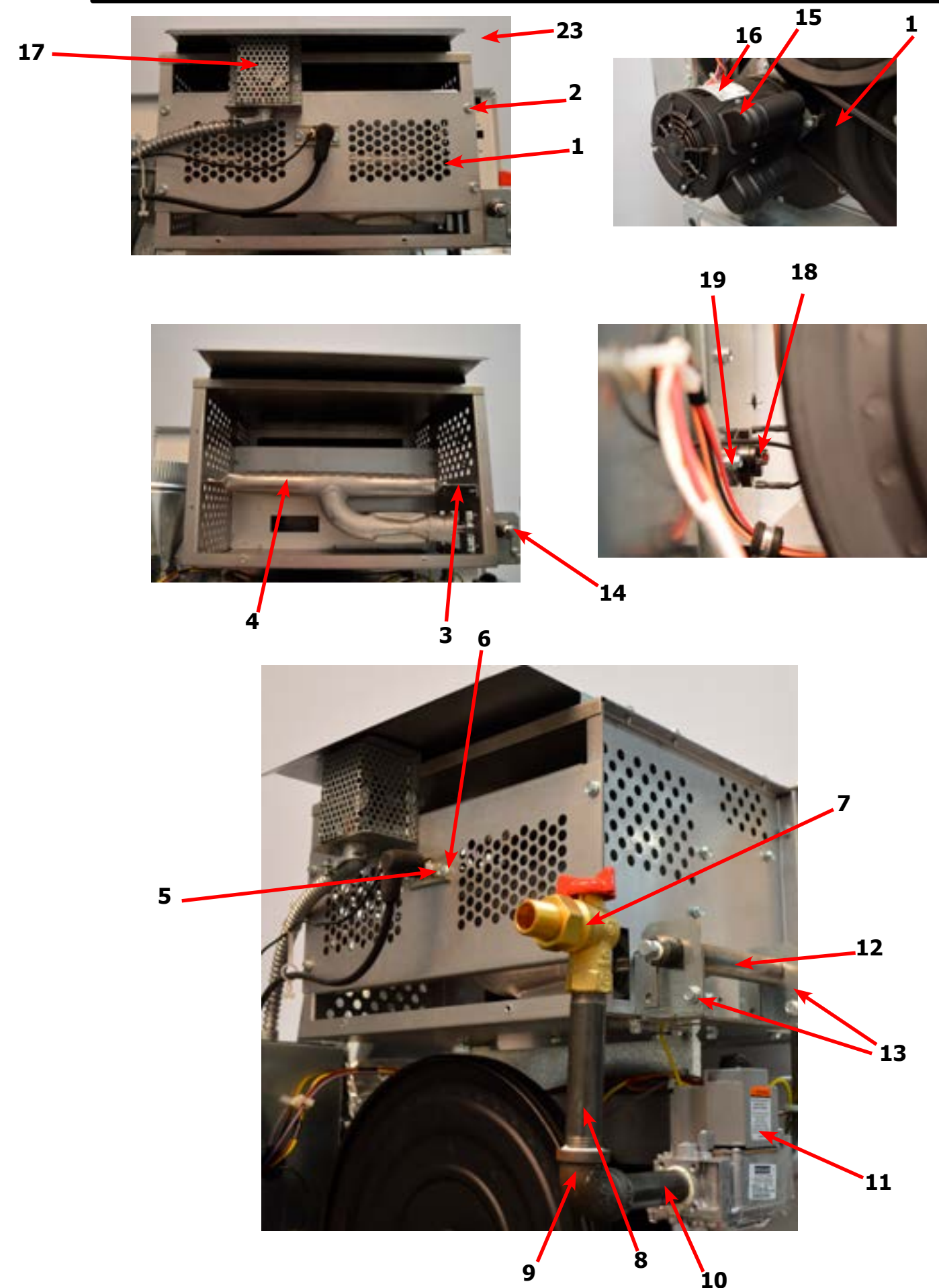

# Control Assembly Group

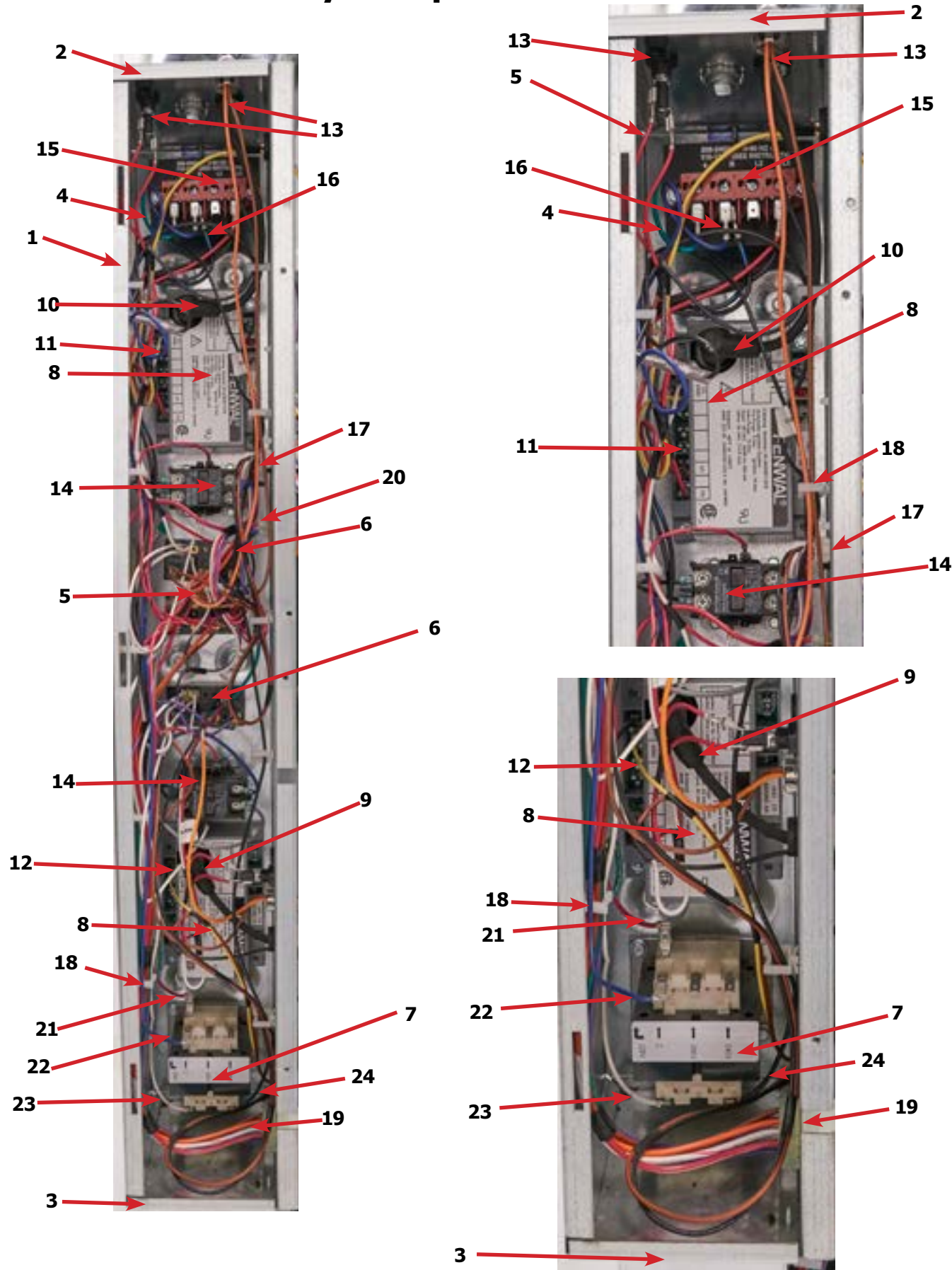

Key	Description	T-20X2	QTY
*	Control, Rear	9857-250-001	1
1	Wrapper-controlbox	9636-219-001	1
2	Panel-upper,controlbox	9454-974-001	1
3	Panel-lower,controlbox	9454-973-001	1
*	Screw-hxwshrundrcuthd,10abx3/8	9545-008-024	6
4	Wireasy-grn/yel,7"	8220-137-002	1
*	Screw-hxwshrdsl,10-32tx1/2grn	9545-008-027	1
*	Lockwasher-exttooth,#10	8641-582-006	1
5	Terminalblockassembly-power	9897-026-002	1
6	Terminalblockassembly-power	9897-026-001	2
*	Screw-panhdcr,#8abx1/2	9545-045-012	6
7	Transformer	8711-013-001	1
*	Screw-hxwshrundrcuthd,10abx3/8	9545-008-024	4
8	Controlsassy-ignition	9857-182-001	2
*	Screw-hxwshd,10abx3/4	9545-008-018	4
9	Wireasy-highvoltage,#8,181/2"	9631-403-008	1
10	Wireasy-highvoltage,#7,291/4"	9631-403-009	1
11	Wiringharness-ignitioncontrol Upper	9627-867-005	1
12	Wiringharness-ignitioncontrol lower	9627-867-006	1
*	Plug-plastic,7/8"	9456-041-006	2
*	Bushing-wire,7/8	9053-067-002	4
*	Connector-conduit,3/8",str	8653-068-003	1
13	Fuseholderassembly	9200-001-002	3
*	Fuse-1.5a,fast,1/4x1-1/4	8636-018-001	2
*	Fuse-2.5a,fast,1/4x1-1/4	8636-018-004	1
14	Relay-motor,30amp,24vac	5192-299-002	2
*	Screw-panhdcr,#8abx1/2	9545-045-012	4
*	Wireasy-red/blk,#9,14"	8220-062-036	1
*	Wireasy-red/wht,#10,14"	8220-062-037	1
*	Wireasy-wht,#11,14"	8220-062-038	2
15	Bracket-powerblock	9029-202-001	1
*	Screw-hxwshrundrcuthd,10abx3/8	9545-008-024	2
*	Terminalblockasy-power,4pole	9897-035-001	1
*	Screw-hxwshrundrcuthd,10abx3/8	9545-008-024	2
*	Strip-marker,terminal	9558-029-003	1
16	Wiringharness-power,main,fork	9627-859-003	1
17	Wiringharness-mainextension	9627-863-001	1
18	Standoff-wiresaddlew/arrowhead	9527-007-001	22
19	Wiringharness-motorext,w/fork Lower	9627-864-006	1
20	Wiringharness-motorextension Upper	9627-864-011	1
*	Screw-pnhdcr,6bx3/8	9545-031-005	4
*	Screw-hxwshrdsl,10-32tx1/2grn	9545-008-027	2
*	Lockwasher-exttooth,#10	8641-582-006	2
21	Wireasy-red,37"	8220-095-011	1
22	Wireasy-blu,42"	8220-095-012	1
23	Wireasy-wht,22"	8220-095-048	1
24	Wireasy-blk,#30,45"	8220-095-046	1



## Door Switch Group

Key	Description	T-20X2	QTY
1	Door Switches	9539-487-001	2
2	Bracket-Mounting lint tray switch	9029-297-001	1
3	Conduit-Wire	6068-049-001	1
*	Grommet Wire 1/2 i.d.	9029-089-001	1

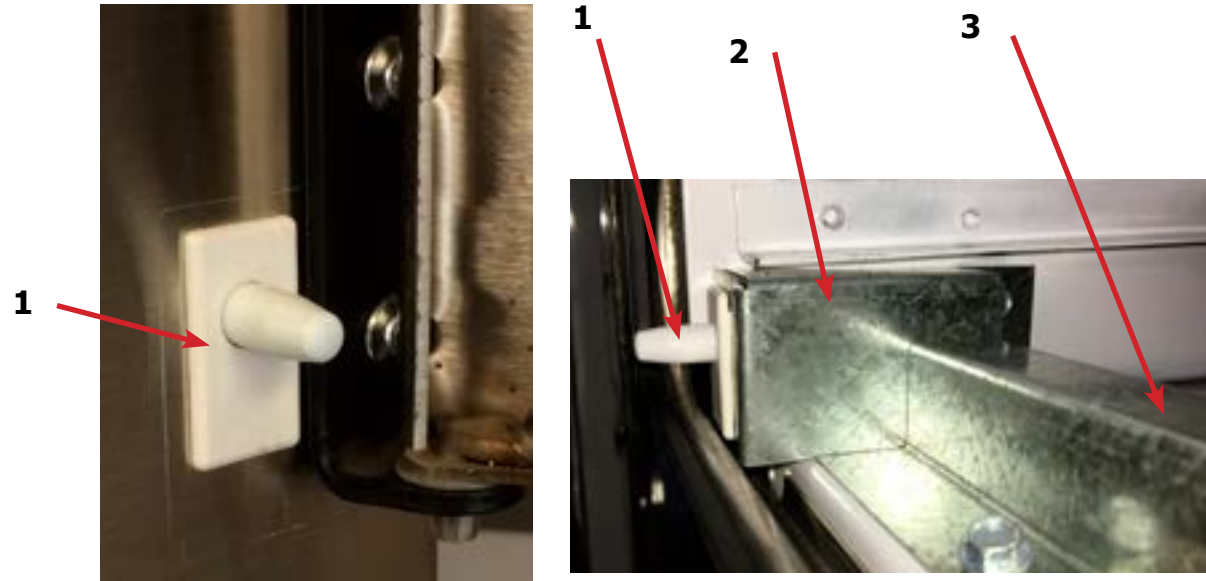

## Hinge Plate Cover

Key	Description	T-20X2	QTY
1	Cover-Hinge, Black	9074-377-002	1
2	Screw-TRHDCR, 10B x 3/8, Black	9545-008-010	2

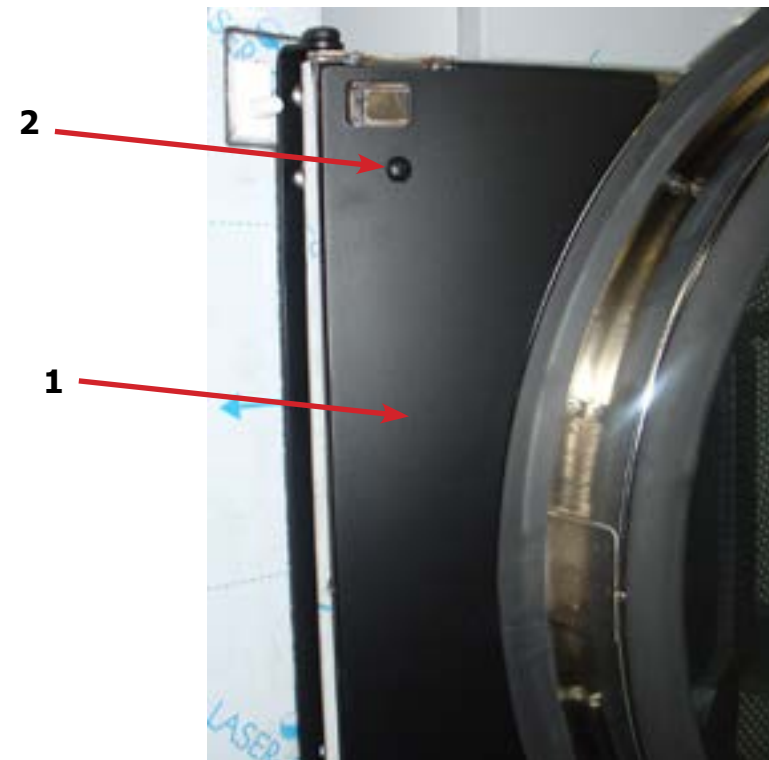

## Control Group

Key	Description	T-20X2	QTY
1	Control Assembly	9857-187-003	1
2	Tray Assembly	9826-006-001	1
3	PCB Assembly Control	9471-017-001	1
4	PCB Assembly Display	9471-018-001	1
5	Screw-panhdcr, #6-32x1/2(ss)	9545-044-010	10
6	Lockwasher-exttooth, #6	8641-582-005	10
7	Washer-flat, nylon (black)	8641-589-001	1
8	Membrane Switch Assembly	9801-105-001	1
9	Terminal-Grounding	8652-130-038	1
10	Screw-hxwshdsl, 10Bx1/4	9545-008-001	2
11	Spring-flat, control assembly	9534-365-001	1
12	Ribbon-cable, control-upper	9500-007-001	1
13	Ribbon-cable, control-lower	9500-007-002	1

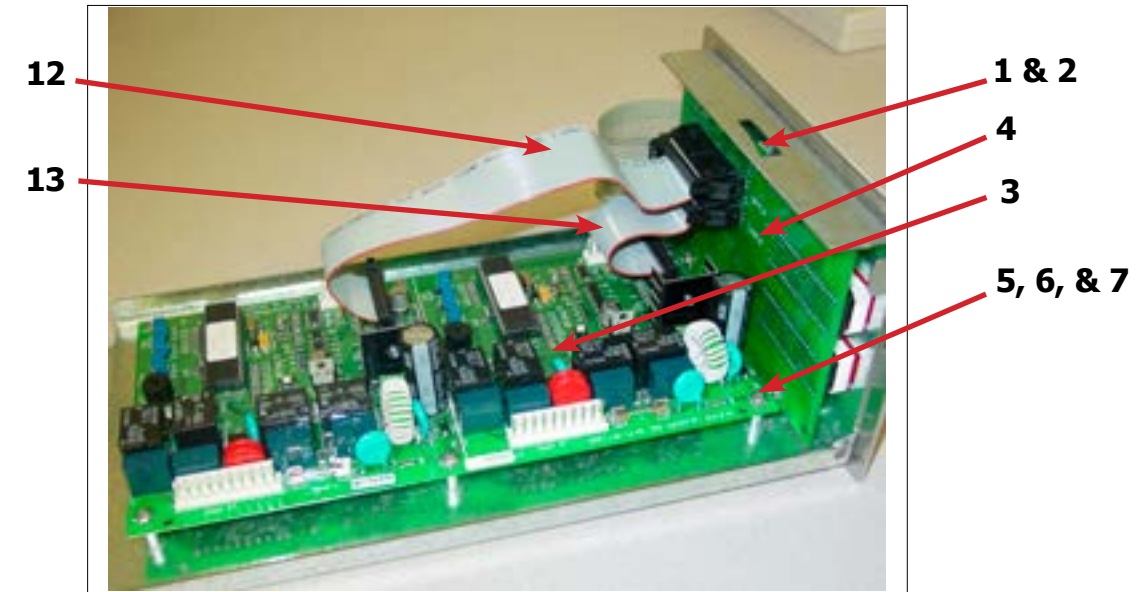





## DN20X2 -84

Key	Description	T-20X2	QTY
	Wire-BLK, 26"	8220-078-024	2
	Wire-BLK, 8"	8220-057-015	6
	Wire-WHT, 5.5", 18 AWG	8220-057-021	2
	Wire-BLK, 9.5", 10 AWG	8220-057-023	12
	Wire-BLK, 36", 12 AWG	8220-057-031	1
	Wire-RED, 36", 12 AWG	8220-057-032	1
	Wire-BLK, 17", 10 AWG	8220-061-011	12
	Wire-WHT/BLK, 65", 18 AWG	8220-063-020	1
	Wire-BLK, 22", 18 AWG	8220-078-014	2
	Wire-BRN, 54", 18 AWG	8220-095-023	2
	Wire-RED, 19", 18 AWG	8220-103-002	2
	Wrapper-Housing, Heater	9636-217-001	2
	Screw-10B x 1/4	9545-008-001	6
	Side-Housing, Heater, Right Hand	9551-063-001	2
	Side-Housing, Heater, Left Hand	9551-064-001	2
	Side Control Heater	9551-040-001	4
	Deflector-Bottom Housing	9114-052-001	2
	Screw-10AB x 3/8	9545-008-024	6
	Bottom-Housing, Heater	9058-029-001	2
	Screw-10AB x 3/8	9545-008-024	22
	Deflector-Wrapper, Housing	9114-053-001	2
	Screw-10AB x 3/8	9545-008-024	8
	Baffle-Housing, Heater	9049-116-001	2
	Wrapper-Control, Heater	9636-218-001	2
	Cover-Plate, Heater	9074-376-001	2
	Side-Control, Heater	9551-040-001	4
	Screw-10AB x 3/8	9545-008-024	16
	Cover-Control, Heater	9074-375-001	2
	Thermostat-Overtemp, Manual Reset	9576-207-006	2
	Rail-Din, 35 x 15mm	9488-011-002	2
	Relay	5192-285-004	2
	Relay, Heatings Element	5192-291-001	2
	Varister-Coil Supressor	9377-003-001	2
	Circuit Breaker, 3-Pole	5198-213-004	4
	Terminal-Lug, Solderless	8652-134-002	4
	Heater Element, 10KW 208V	9870-093-002	6
	Jumper-Formed	9295-004-002	4
	Jumper-Straight	9295-005-002	8

## DN20X2 -84

Key	Description	T-20X2	QTY
	Block-Power, 3-Pole	9897-037-001	2
	Block-Power, 1-Pole	9897-038-001	2
	Wiring-Diagram/Schematic	9506-858-001	1
	Booklet-Owners	8514-265-001	1

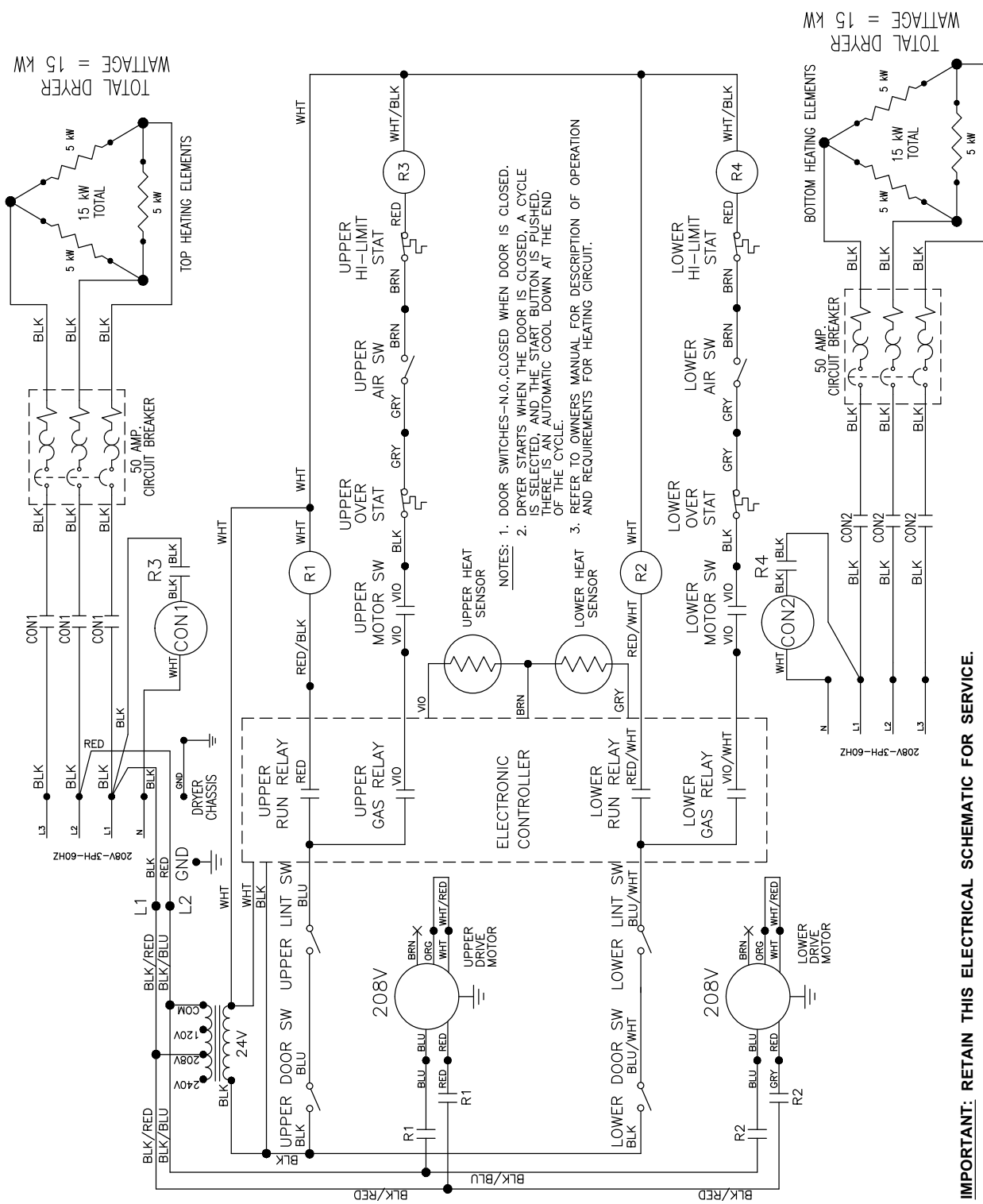

IMPORTANT: RETAIN THIS ELECTRICAL SCHEMATIC FOR SERVICE.

9506-858-001PR

SCHEMATIC

DN20X2E\_-84\_B\_X\_-\_\_X

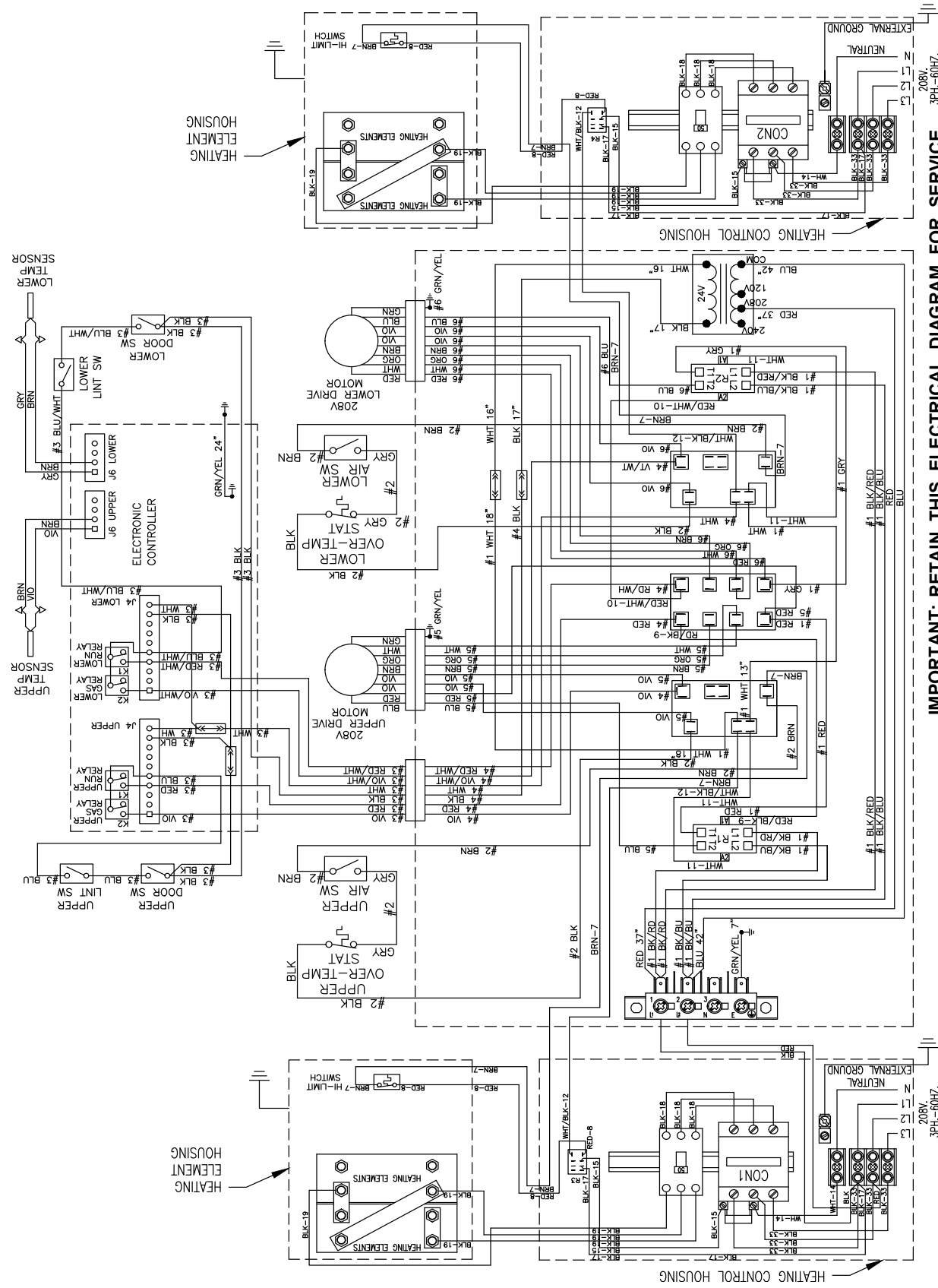

IMPORTANT: RETAIN THIS ELECTRICAL DIAGRAM FOR SERVICE.

9506-858-001PR

WIRING DIAGRAM

DN20X2E\_-84\_B\_X\_-\_\_X

## DN20X2 -85

Key	Description	T-20X2	QTY
	Wire-BLK, 26"	8220-078-024	2
	Wire-BLK, 8"	8220-057-015	6
	Wire-WHT, 5.5", 18 AWG	8220-057-021	2
	Wire-BLK, 9.5", 10 AWG	8220-057-023	12
	Wire-BLK, 36", 12 AWG	8220-057-031	1
	Wire-RED, 36", 12 AWG	8220-057-032	1
	Wire-BLK, 17", 10 AWG	8220-061-011	12
	Wire-WHT/BLK, 65", 18 AWG	8220-063-020	1
	Wire-BLK, 22", 18 AWG	8220-078-014	2
	Wire-BRN, 54", 18 AWG	8220-095-023	2
	Wire-RED, 19", 18 AWG	8220-103-002	2
	Wrapper-Housing, Heater	9636-217-001	2
	Screw-10B x 1/4	9545-008-001	6
	Side-Housing, Heater, Right Hand	9551-063-001	2
	Side-Housing, Heater, Left Hand	9551-064-001	2
	Side Control Heater	9551-040-001	4
	Deflector-Bottom Housing	9114-052-001	2
	Screw-10AB x 3/8	9545-008-024	6
	Bottom-Housing, Heater	9058-029-001	2
	Screw-10AB x 3/8	9545-008-024	22
	Deflector-Wrapper, Housing	9114-053-001	2
	Screw-10AB x 3/8	9545-008-024	8
	Baffle-Housing, Heater	9049-116-001	2
	Wrapper-Control, Heater	9636-218-001	2
	Cover-Plate, Heater	9074-376-001	2
	Side-Control, Heater	9551-040-001	4
	Screw-10AB x 3/8	9545-008-024	16
	Cover-Control, Heater	9074-375-001	2
	Thermostat-Overtemp, Manual Reset	9576-207-006	2
	Rail-Din, 35 x 15mm	9488-011-002	2
	Relay	5192-285-004	2
	Relay, Heatings Element	5192-291-001	2
	Varister-Coil Supressor	9377-003-001	2
	Circuit Breaker, 3-Pole	5198-213-003	4
	Terminal-Lug, Solderless	8652-134-002	4
	Heater Element, 10KW 240V	9870-093-001	6
	Jumper-Formed	9295-004-002	4
	Jumper-Straight	9295-005-002	8

## DN20X2 -85

Key	Description	T-20X2	QTY
	Block-Power, 3-Pole	9897-037-001	2
	Block-Power, 1-Pole	9897-038-001	2
	Wiring-Diagram/Schematic	9506-859-001	1
	Booklet-Owners	8514-265-001	1

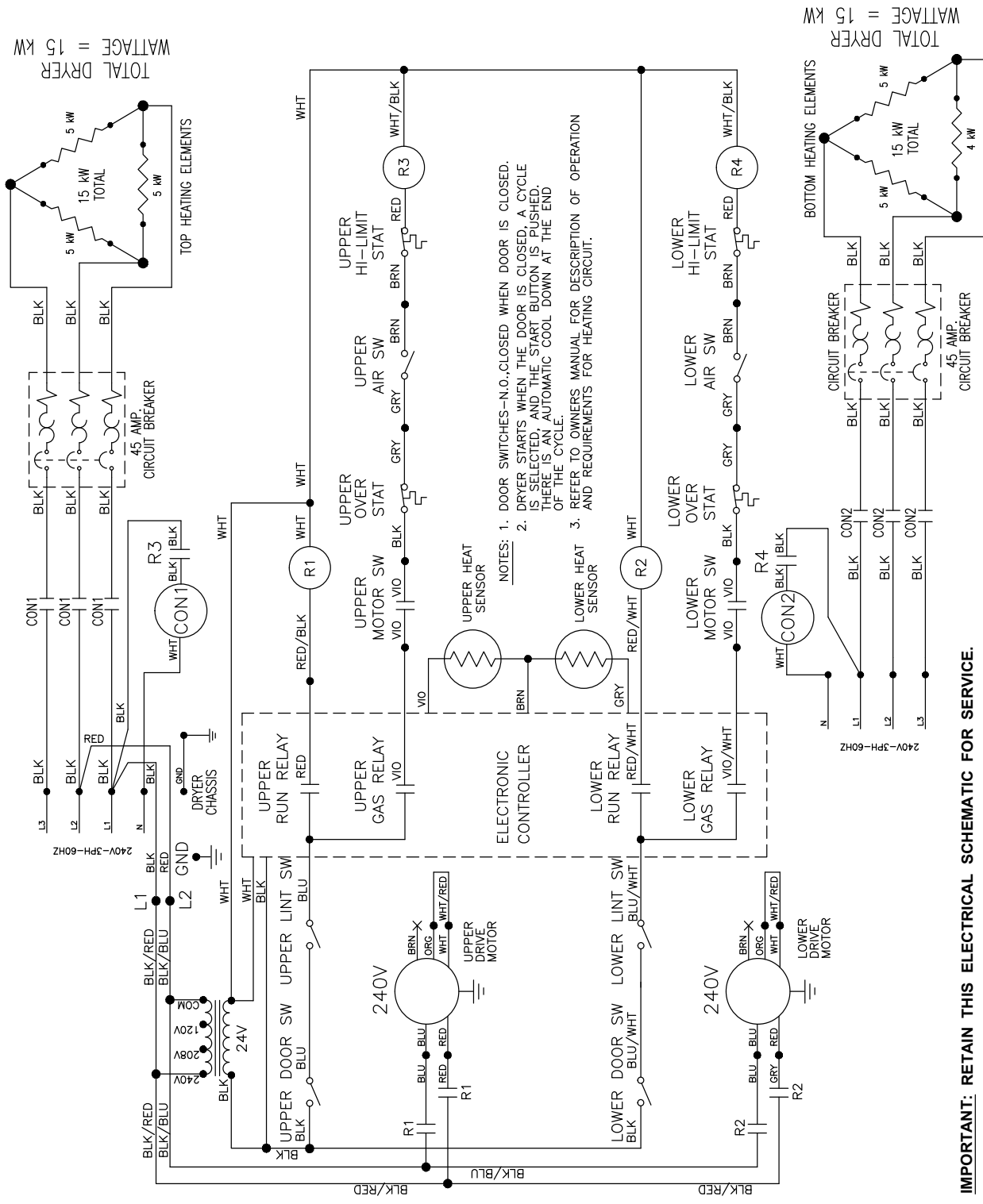

**IMPORTANT: RETAIN THIS ELECTRICAL SCHEMATIC FOR SERVICE.**

9506-859-001PR

SCHEMATIC

DN20X2E\_-85\_B\_X\_-\_\_X

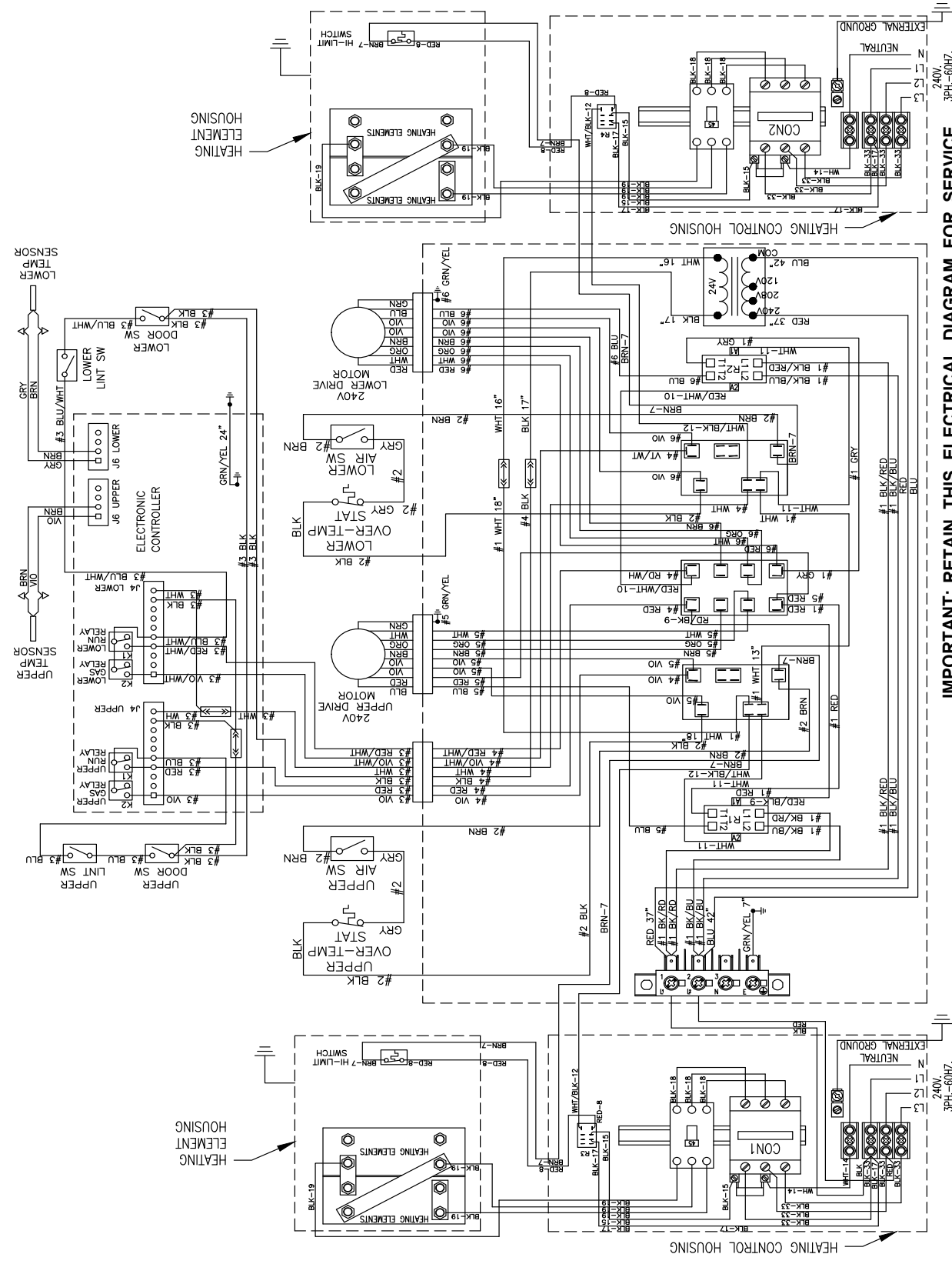



## DN20X2 -86

Key	Description	T-20X2	QTY
	Wire-BLK, 26"	8220-078-024	2
	Wire-BLK, 8"	8220-057-014	6
	Wire-WHT, 5.5", 18 AWG	8220-057-021	2
	Wire-BLK, 9.5", 10 AWG	8220-057-023	12
	Wire-BLK, 36", 12 AWG	8220-057-031	1
	Wire-RED, 36", 12 AWG	8220-057-032	1
	Wire-BLK, 17", 10 AWG	8220-061-011	12
	Wire-WHT/BLK, 65", 18 AWG	8220-063-020	1
	Wire-BLK, 22", 18 AWG	8220-078-014	2
	Wire-BRN, 54", 18 AWG	8220-095-023	2
	Wire-RED, 19", 18 AWG	8220-103-002	2
	Wrapper-Housing, Heater	9636-217-001	2
	Screw-10B x 1/4	9545-008-001	6
	Side-Housing, Heater, Right Hand	9551-063-001	2
	Side-Housing, Heater, Left Hand	9551-064-001	2
	Side Control Heater	9551-040-001	4
	Deflector-Bottom Housing	9114-052-001	2
	Screw-10AB x 3/8	9545-008-024	6
	Bottom-Housing, Heater	9058-029-001	2
	Screw-10AB x 3/8	9545-008-024	22
	Deflector-Wrapper, Housing	9114-053-001	2
	Screw-10AB x 3/8	9545-008-024	8
	Baffle-Housing, Heater	9049-116-001	2
	Wrapper-Control, Heater	9636-218-001	2
	Cover-Plate, Heater	9074-376-001	2
	Side-Control, Heater	9551-040-001	4
	Screw-10AB x 3/8	9545-008-024	16
	Cover-Control, Heater	9074-375-001	2
	Thermostat-Overtemp, Manual Reset	9576-207-006	2
	Rail-Din, 35 x 15mm	9488-011-002	2
	Relay	5192-285-004	2
	Relay, Heatings Element	5192-294-001	2
	Varister-Coil Supressor	9377-003-001	2
	Circuit Breaker, 2-Pole	5198-214-002	4
	Terminal-Lug, Solderless	8652-134-002	4
	Heater Element, 8KW 208V	9870-093-004	6
	Jumper-Straight	9295-005-002	8

## DN20X2 -86

Key	Description	T-20X2	QTY
	Block-Power, 3-Pole	9897-037-001	2
	Block-Power, 1-Pole	9897-038-001	2
	Wiring-Diagram/Schematic	9506-860-001	1
	Booklet-Owners	8514-265-001	1

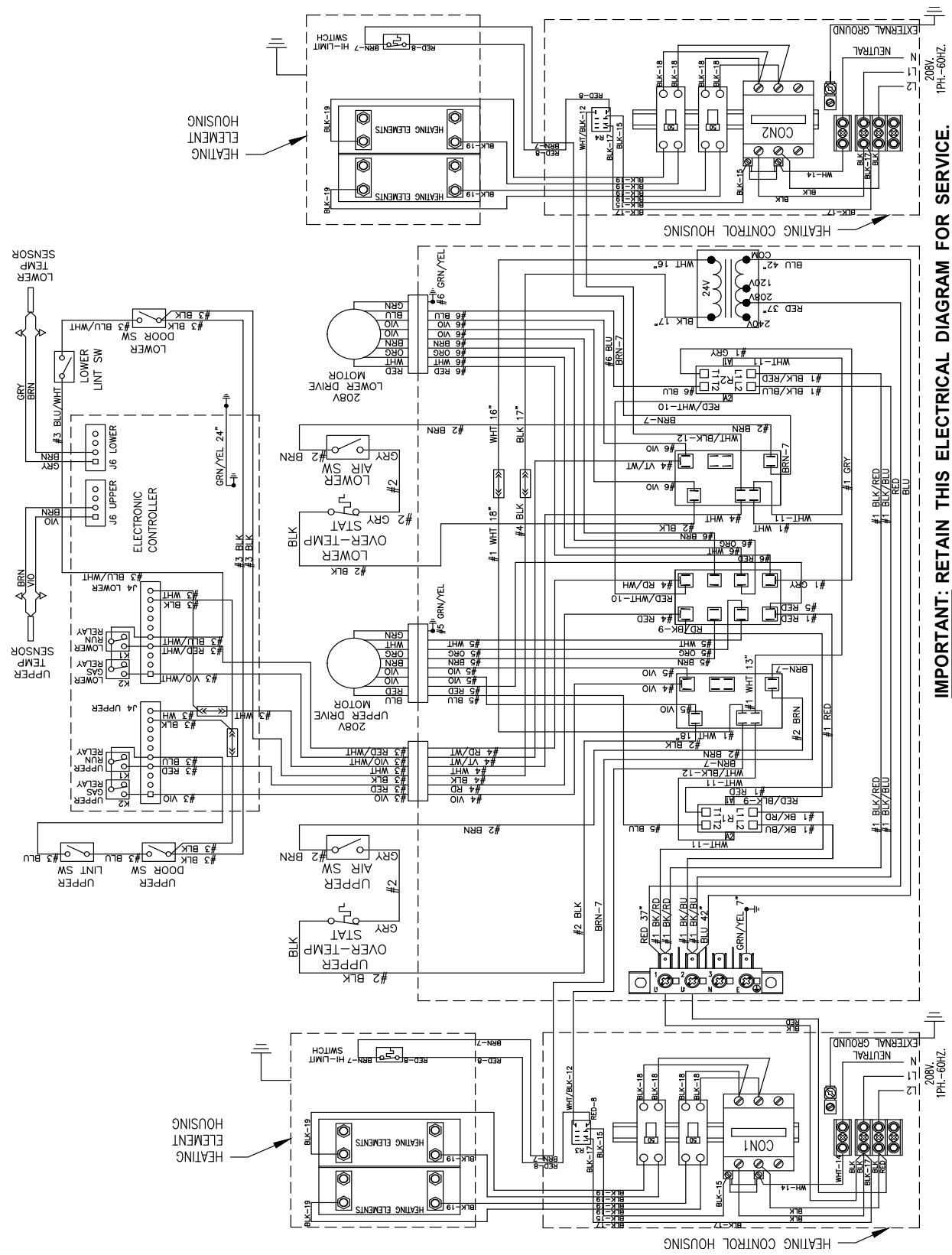
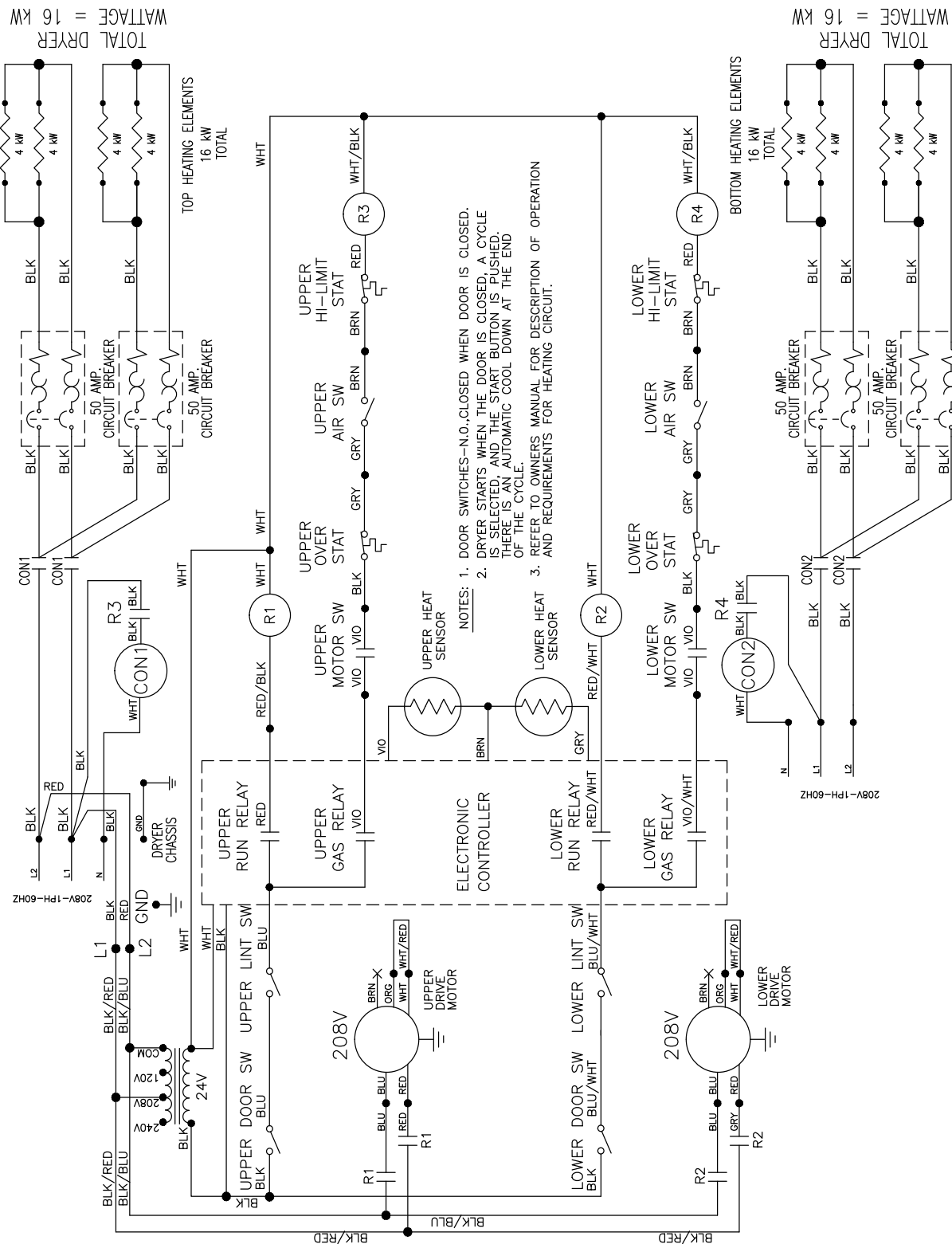

## DN20X2 -87

Key	Description	T-20X2	QTY
	Wire-BLK, 26"	8220-078-024	2
	Wire-BLK, 8"	8220-057-016	6
	Wire-WHT, 5.5", 18 AWG	8220-057-021	2
	Wire-BLK, 9.5", 10 AWG	8220-057-023	12
	Wire-BLK, 36", 12 AWG	8220-057-031	1
	Wire-RED, 36", 12 AWG	8220-057-032	1
	Wire-BLK, 17", 10 AWG	8220-061-011	12
	Wire-WHT/BLK, 65", 18 AWG	8220-063-020	1
	Wire-BLK, 22", 18 AWG	8220-078-014	2
	Wire-BRN, 54", 18 AWG	8220-095-023	2
	Wire-RED, 19", 18 AWG	8220-103-002	2
	Wrapper-Housing, Heater	9636-217-001	2
	Screw-10B x 1/4	9545-008-001	6
	Side-Housing, Heater, Right Hand	9551-063-001	2
	Side-Housing, Heater, Left Hand	9551-064-001	2
	Side Control Heater	9551-040-001	4
	Deflector-Bottom Housing	9114-052-001	2
	Screw-10AB x 3/8	9545-008-024	6
	Bottom-Housing, Heater	9058-029-001	2
	Screw-10AB x 3/8	9545-008-024	22
	Deflector-Wrapper, Housing	9114-053-001	2
	Screw-10AB x 3/8	9545-008-024	8
	Baffle-Housing, Heater	9049-116-001	2
	Wrapper-Control, Heater	9636-218-001	2
	Cover-Plate, Heater	9074-376-001	2
	Side-Control, Heater	9551-040-001	4
	Screw-10AB x 3/8	9545-008-024	16
	Cover-Control, Heater	9074-375-001	2
	Thermostat-Overtemp, Manual Reset	9576-207-006	2
	Rail-Din, 35 x 15mm	9488-011-002	2
	Relay	5192-285-004	2
	Relay, Heatings Element	5192-296-001	2
	Varister-Coil Supressor	9377-003-001	2
	Circuit Breaker, 2-Pole	5198-214-003	4
	Terminal-Lug, Solderless	8652-134-002	4
	Heater Element, 8KW 240V	9870-093-003	6
	Jumper-Straight	9295-005-002	8

## DN20X2 -87

Key	Description	T-20X2	QTY
	Block-Power, 3-Pole	9897-037-001	2
	Block-Power, 1-Pole	9897-038-001	2
	Wiring-Diagram/Schematic	9506-861-001	1
	Booklet-Owners	8514-265-001	1

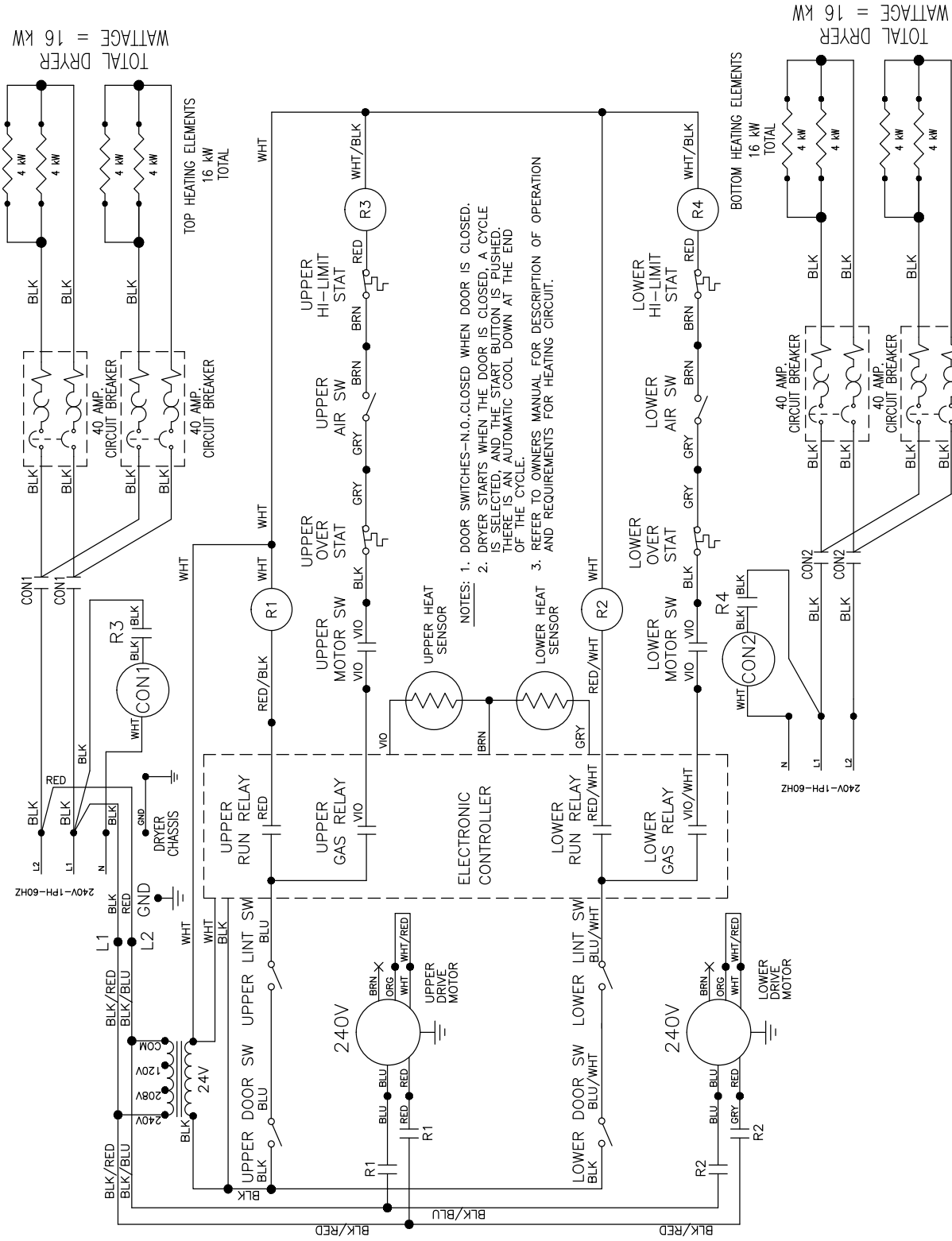

IMPORTANT: RETAIN THIS ELECTRICAL SCHEMATIC FOR SERVICE.

9506-861-001PR SCHEMATIC DN20X2E-87\_B\_X-\_-X

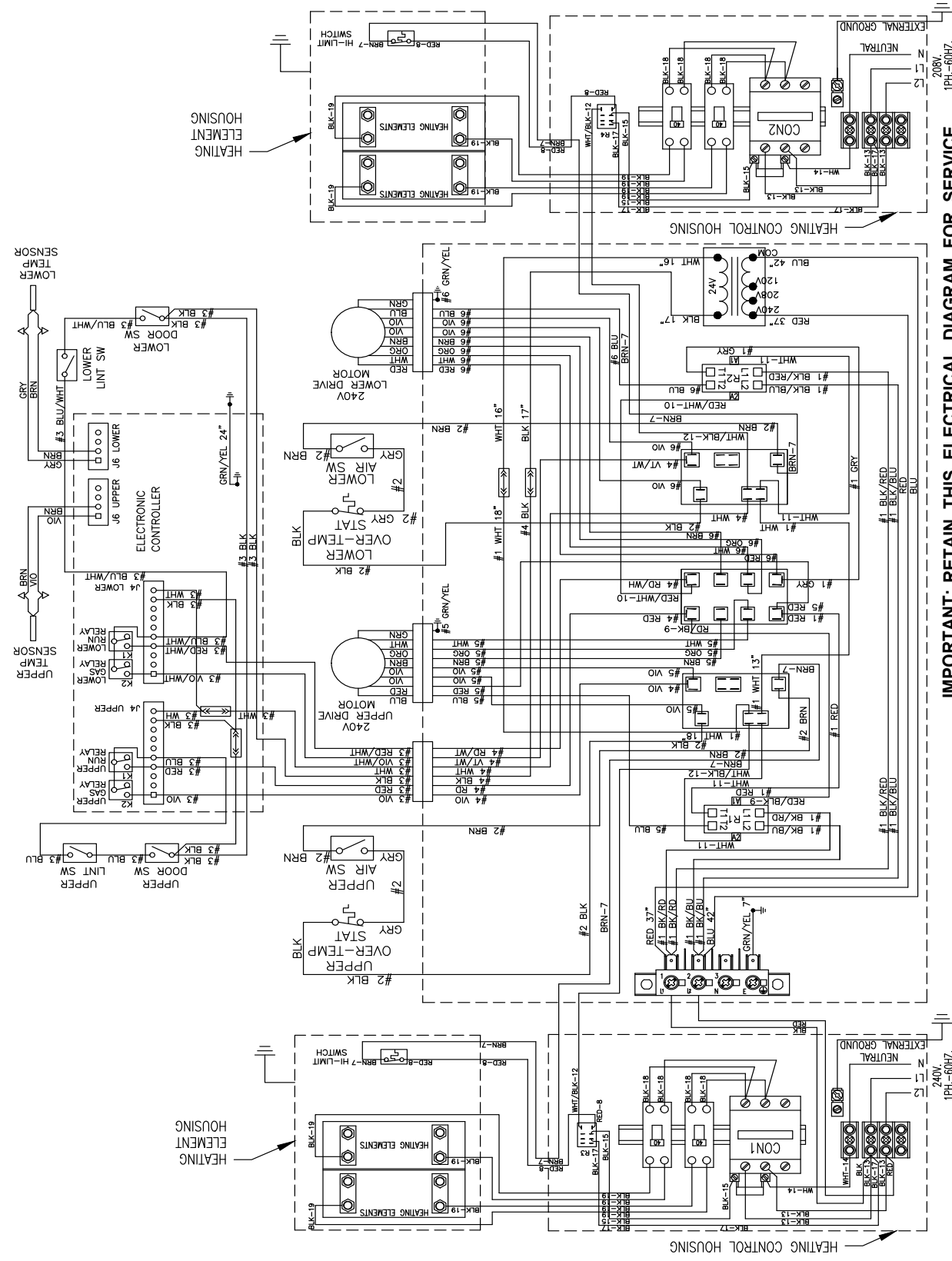

IMPORTANT: RETAIN THIS ELECTRICAL DIAGRAM FOR SERVICE.

9506-861-001PR WIRING DIAGRAM DN20X2E-87\_B\_X-\_-X





**Notes**

Lined area for notes.

**Section 9:**  
50 Hz  
Electric Heated

