



DEXTER[®]
LAUNDRY

**USE THE BLUE TABS LOCATED ON THE
RIGHT AND LEFT SIDES OF THE FOLLOWING
DOCUMENT TO ADVANCE TO EACH SECTION.**



DEXTER
LAUNDRY

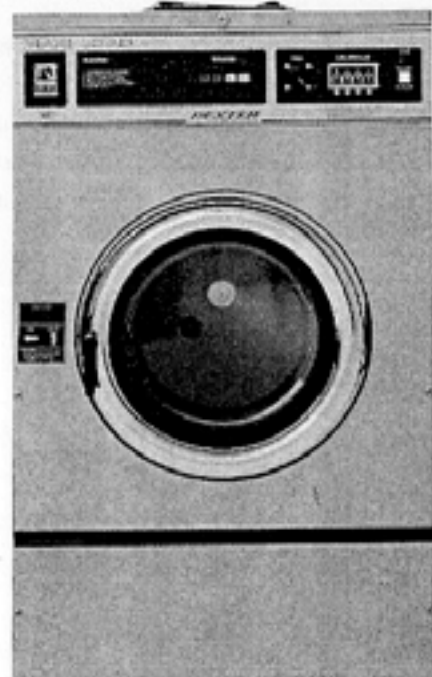
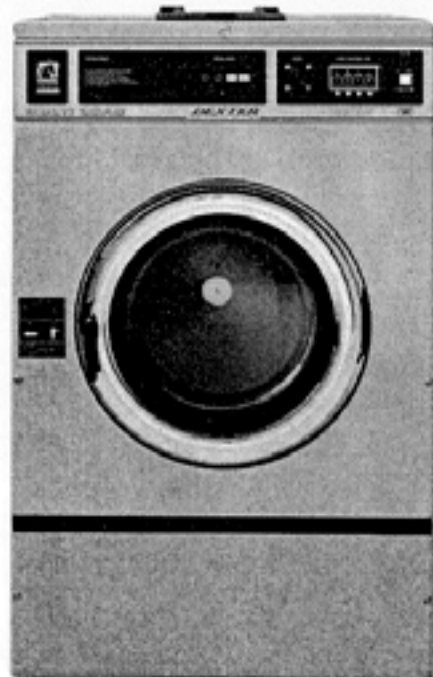





N-Series On-Premise Washers WCN__DX

- WCN25AADX
- WCN25ABDX
- WCN40AADX
- WCN40ABDX

Non-Express

Equipment Safety Warnings Symbols and Terminology Used in this Equipment

⚠ DANGER	Indicates an imminently hazardous situation, which if not avoided, will result in death or serious injury.
⚠ WARNING	Indicates a potentially hazardous situation, which if not avoided could result in death or serious injury.
⚠ CAUTION	Indicates a potentially hazardous situation which, if not avoided, may result in minor or moderate injury. It may also be used to alert against unsafe practices. Minor burns, pinch points that result in bruises and minor chemical irritation.
NOTICE	Indicates information or a company policy that relates directly or indirectly to the safety of personnel or protection of property.
	This is the user caution symbol. It indicates a condition where damage to the equipment resulting in injury to the operator could occur if operational procedures are not followed. TO REDUCE THE RISK OF DAMAGE OR INJURY , refer to accompanying documents; follow all steps or procedures as instructed.
	This is the electrical hazard symbol. It indicates that there are DANGEROUS HIGH VOLTAGES PRESENT inside the enclosure of this product. TO REDUCE THE RISK OF FIRE OR ELECTRIC SHOCK , do not attempt to open the enclosure or gain access to areas where you are not instructed to do so. REFER SERVICING TO QUALIFIED SERVICE PERSONEL ONLY
	Caution! There are sharp edges on various sheet metal parts internal to the enclosure. Use safety consciousness when placing or moving your hands while working in the interior of this equipment.
	Caution! To reduce the risk of damage to the Water Inlet Valve, do not supply inlet water with a temperature that exceeds 70° C. Caution! To reduce the risk of fire or explosion, do not operate this equipment in any hazardous classified (ATEX) environment.

Equipment Safety Warnings Symbols and Terminology Used in this Equipment



Warning! Do not operate equipment if door glass is damaged in any way.



Warning! Keep clear of rotating parts.



Prohibited! Do not enter this equipment or space.



Prohibited! Do not step or stand on this equipment.

Prohibited! Do not operate without all guards and covers in place.









Prohibited! Do not operate without all guards and covers in place.



Prohibited! Do not wash clothing impregnated with flammable liquids (petrochemical).



Prohibited! Do not allow children to play in or around equipment.

 DANGER	Indicates an imminently hazardous situation, which if not avoided, <u>will result</u> in death or serious injury.
 WARNING	Indicates a potentially hazardous situation, which if not avoided <u>could result</u> in death or serious injury.
 CAUTION	Indicates a potentially hazardous situation which, if not avoided, <u>may result</u> in minor or moderate injury. It may also be used to alert against unsafe practices. Minor burns, pinch points that result in bruises and minor chemical irritation.
NOTICE	Indicates information or a company policy that relates directly or indirectly to the safety of personnel or protection of property.
	This is the user caution symbol. It indicates a condition where damage to the equipment resulting in injury to the operator could occur if operational procedures are not followed. TO REDUCE THE RISK OF DAMAGE OR INJURY, refer to accompanying documents; follow all steps or procedures as instructed.
	This is the electrical hazard symbol. It indicates that there are DANGEROUS HIGH VOLTAGES PRESENT inside the enclosure of this product. TO REDUCE THE RISK OF FIRE OR ELECTRIC SHOCK, do not attempt to open the enclosure or gain access to areas where you are not instructed to do so. REFER SERVICING TO QUALIFIED SERVICE PERSONEL ONLY
	Caution! To reduce the risk of fire or explosion, do not operate this equipment in any hazardous classified (ATEX) environment.



WARNING



- All washers must be installed in accordance to all applicable electrical, plumbing and all other local codes.
- These installation and operation instructions are for use by qualified personnel only. To avoid injury and electrical shock, do not perform any servicing other than that contained in the installation and operation instructions, unless qualified.



Do not install washers in an explosive atmosphere.



- Care must be stressed with all foundation work to ensure a stable unit installation, eliminating possibilities of excessive vibration.
- Foundation must be level within 13 mm to ensure proper washer operation.



Do not operate washer if door glass is damaged in any way.



Do not wash clothing impregnated with flammable liquids (petrochemical).



WARNING



Children should be supervised to ensure they do not operate or play in or around equipment.









Keep all panels in place to protect against electrical shock and injury and add rigidity to washer.

This appliance is not intended for use by persons (including children) with reduced physical, sensory or mental capabilities, or lack of experience and knowledge, unless they have been given supervision or instruction concerning use of the appliance by a person responsible for their safety.

A washer should not be allowed to operate if any of the following occur:

- Excessive high water level.
- Machine is not connected to a properly earthed circuit.
- Door does not remain securely locked during the entire cycle.
- Vibration or shaking from an inadequate mounting or foundation

	Warning! Do not operate equipment if door glass is damaged in any way.
	Warning! Keep clear of rotating parts.
	Prohibited! Do not enter this equipment or space.
	Prohibited! Do not step or stand on this equipment.
	Prohibited! Do not operate without all guards and covers in place.
	Prohibited! Do not operate without all guards and covers in place.
	Prohibited! Do not wash clothing impregnated with flammable liquids (petrochemical).
	Prohibited! Do not allow children to play in or around equipment.

	Prohibited! Do not attempt to open, touch, or proceed before referring to the manual or unless qualified.
	Mandatory! Read all supporting documentation before operating or maintaining equipment.
	Mandatory! Disconnect power before servicing equipment.
	Mandatory! Lock out and tag out before servicing this equipment.
	Mandatory! Disconnect water supply before servicing equipment.
	Mandatory! Children should be supervised to ensure they do not operate equipment.

Section 1:

Machine Mounting

Specifications for below models are outlined in this book:

WCN25AADX	220-240 volts	60hz.	Single Phase
WCN25ABDX	208-240 volts	60hz.	Three Phase
WCN40AADX	220-240 volts	60hz.	Single Phase
WCN40ABDX	208-240 volts	60hz.	Three Phase

Cycle Times	Rotary Switch Position #1	Rotary Switch Position #2	Rotary Switch Position #3	Rotary Switch Position #4	Chemical Signal	Water Level
Flush	3 minutes	3 minutes	Not Used	Not Used	No	High
Drain	42 seconds	42 seconds	Not Used	Not Used		
Preswash	3 minutes	3 minutes	3 minutes	3 minutes	Yes -- A	High
Drain	42 seconds	42 seconds	42 seconds	42 seconds		
Wash	7 minutes	7 minutes	7 minutes	7 minutes	Yes -- B	Low
Drain	49 seconds	49 seconds	49 seconds	49 seconds		
Rinse 1	2 minutes	Not Used	2 minutes	2 minutes	No	High
Drain	41 seconds	Not Used	41 seconds	41 seconds		
Rinse 2	7 minutes	7 minutes	7 minutes	Not Used	Yes -- C	Low
Drain	49 seconds	49 seconds	49 seconds	Not Used		
Rinse 3	2 minutes	2 minutes	2 minutes	2 minutes	No	High
Drain	41 seconds	41 seconds	41 seconds	41 seconds		
Int. Spin	2 minutes	2 minutes	2 minutes	2 minutes		
Rinse 4	2 minutes	2 minutes	2 minutes	2 minutes	No	High
Drain	41 seconds	41 seconds	41 seconds	41 seconds		
Rinse 5	4 minutes	4 minutes	4 minutes	4 minutes	Yes -- D	Low
Drain	41 seconds	41 seconds	41 seconds	41 seconds		
Extract	5 minutes	4 minutes	5 minutes	3.5 minutes		
Tumble	37 seconds	37 seconds	37 seconds	37 seconds		
Total*	43 minutes	39.5 minutes	39.5 minutes	30.5 minutes		

*Cycle times are approximate and do not include fill time from empty to low level. Fill time from low to high level is included as timer operates during this period.

Water Temp	Push-Button Temp Switch #1	Push-Button Temp Switch #2	Push-Button Temp Switch #3	Push-Button Temp Switch #4
Flush	Warm	Warm	Warm	Cold
Preswash	Warm	Warm	Warm	Cold
Wash	Hot	Warm	Warm	Cold
Rinse 1	Hot	Hot	Warm (Hot OPT)	Cold
Rinse 2	Hot	Hot	Warm (Hot OPT)	Cold
Rinse 3	Warm	Warm	Warm (Cold OPT)	Cold
Rinse 4	Warm	Warm	Warm (Cold OPT)	Cold
Rinse 5	Warm	Warm	Warm (Cold OPT)	Cold

Options

1. Replace all Hot rinses with Warm rinses by removing brn/red wire from coil of R5 relay and insulate.
2. Push button #3 replace Warm rinse 1 & 2 with Hot by removing black jumper wire between push button #3 and push button #4 and connecting the white/brn wire (piggybacked on the black jumper) to push button #4 normally open terminal B1
3. Replace Warm rinse 3,4, &5 on push button #3 by moving brn/org wire from push button #3 common terminal A2 to push button #3 normally closed terminal C2.

Specifications T-400 OPL Washer

Capacity	25lbs.
Dimensions	
Cylinder Depth	14 1/8"
Cylinder Diameter	25"
Cylinder Volume (cubic feet)	4.0
Door Opening	15 1/4"
Door Height (floor to bottom of door)	16 1/2"
Overall Height	48 1/4"
Cabinet Width	29 7/8"
Overall Depth	27 1/8"
Drain Diameter (O.D.)	3"
Drain Height (floor to center of outlet)	5"
Recommended Clearance Between Machines (min)	1/2"
Necessary Service Clearance Behind Machine	24"
Cylinder RPM	
Tumble Speed	50
Extract Speed	510
Extract Speed G-Force	92
Cylinder Direction in Extract	Counter-clockwise
Motor H.P.	
Wash Single Phase	0.35
Wash Three Phase	0.35
Extract Single Phase	1.5
Extract Three Phase	1.5
Amperage (avg. measured on L1)	
Wash Single Phase	3.75
Wash Three Phase	3.5
Extract Single Phase	3
Extract Three Phase	8.5
Running Amps (Maximum)	
Single Phase	13
Three Phase	6.2
Circuit Breaker (Amps)	
Single Phase	20
Three Phase	15
Built-in Controls Circuit Breaker	Yes
Built in Motor Protection	Yes

Voltage 60Hz.	
Single Phase	220-240
Three Phase	208-240
Service	
Single Phase	3 wires + ground
Three Phase	3 wires + ground
Wire Size (Minimum)	
Single Phase	12
Three Phase	12
Water	
Recommended Hot Water (degrees)	140
Water Pressure (min/max)	30-120psi
Water Inlet Size (hose thread)	3/4"
Water Flow Rate (gallons/minute)	9
Wash Cycle	
Wash Temperatures	Hot, Warm, & Cold
Rinse Temperatures	Hot, Warm, & Cold
Mounting Hole Dimensions	
Left to Right	26 7/8"
Front to Cabinet to First Hole	2 1/2"
First Hole to Second Hole	14 1/2" or 17 1/8"
Second Hole to Third Hole	N/A
Mounting Bolt Diameter	1/2" or 5/8"
Hole Diameter in Base	3/4"
Concrete Thickness (min)	6"
Recommended Mounting Height	4" to 6"
Weight	
Shipping (lbs.)	503/1p 495/3p
Net (lbs.)	485/1p 477/3p

Specifications T-600 OPL Washer

Capacity	40lbs.
Dimensions	
Cylinder Depth	21 1/8"
Cylinder Diameter	25"
Cylinder Volume (cubic feet)	6.0
Door Opening	15 1/4"
Door Height (floor to bottom of door)	16"
Overall Height	49 3/4"
Cabinet Width	29 7/8"
Overall Depth	35 7/8"
Drain Diameter (O.D.)	3"
Drain Height (floor to center of outlet)	5"
Recommended Clearance Between Machines (min)	1/2"
Necessary Service Clearance Behind Machine	24"
Cylinder RPM	
Tumble Speed	50
Extract Speed	510
Extract Speed G-Force	92
Cylinder Direction in Extract	Counter-clockwise
Motor H.P.	
Wash Single Phase	0.4
Wash Three Phase	0.35
Extract Single Phase	1.8
Extract Three Phase	1.5
Amperage (avg. measured on L1)	
Wash Single Phase	3.75
Wash Three Phase	3.5
Extract Single Phase	3
Extract Three Phase	5.25
Running Amps (Maximum)	
Single Phase	13
Three Phase	6.2
Circuit Breaker (Amps)	
Single Phase	20
Three Phase	15
Built-in Controls Circuit Breaker	Yes
Built in Motor Protection	Yes

Voltage 60Hz.	
Single Phase	220-240
Three Phase	208-240
Service	
Single Phase	3 wires + ground
Three Phase	3 wires + ground
Wire Size (Minimum)	
Single Phase	12
Three Phase	12
Water	
Recommended Hot Water (degrees)	140
Water Pressure (min/max)	30-120psi
Water Inlet Size (hose thread)	3/4"
Water Flow Rate (gallons/minute)	9
Wash Cycle	
Wash Temperatures	Hot, Warm, & Cold
Rinse Temperatures	Hot, Warm, & Cold
Mounting Hole Dimensions	
Left to Right	26 7/8"
Front to Cabinet to First Hole	2 3/4"
First Hole to Second Hole	21 1/2"
Second Hole to Third Hole	N/A
Mounting Bolt Diameter	5/8"
Hole Diameter in Base	3/4"
Concrete Thickness (min)	6"
Recommended Mounting Height	4" to 6"
Weight	
Shipping (lbs.)	680/1p 652/3p
Net (lbs.)	655/1p 627/3p

Cycle Options

Omit All Flushes

1. Remove the clear in-line splice from the end of the orange/white wire. (This wire will be laying loose next to the terminal strip)
2. Connect the orange/white wire to terminal #2 on the terminal strip.

Omit Hot Rinses on Rinse #1 & #2

1. Remove brown/red wire from coil of R5 relay and insulate wire.

Add Hot Rinses on Rinse #1 & Rinse #2 on Temperature Push Button Position #3

1. Remove black jumper from back of temperature switch that connects push button #3 N.O. (B2) to push button #4 N.O. (B1)
2. Move white/brown wire on back of temperature switch to push button #4 N.O. (B1)

Add Cold Rinses on Rinse #3, #4, & #5 on Temperature Push Button Position #3

1. Move brown/orange wire from push button #3 Common (A2) to push button #3 N.C. (C2).

Omit Rinse #4 All Cycles

1. Remove the clear in-line splice from the end of the gray wire. (This wire will be laying loose next to the terminal strip)
2. Connect the gray wire to terminal #2 on the terminal strip.

Wash Formulas

Application	Formula	Mechanical Timer	Rotary Switch Position
Shirt Laundry oxygen bleach	Shirts (No Starch)	X	4 (A)
	Shirts (Starch)	X	4 (A)
Hotel/Motel chlorine bleach	White sheets	X	2 (B)
	White pillowcases	X	1 (B)
	White towels, bath mats, & washclothes	X	3 (B) or 1 (B)
	Colored sheets & towels	X	4 (B) or 1 (B)
	Delicate Wash	X	4 (B)
	Housekeeping rags & mops	X	1 (C)
	Houskeeping Uniforms	X	2 (D)
	Stain Treatment	No	
Reclaim Part 1	No		
Reclaim Part 2	No		
Healthcare chlorine bleach	Sheets & Pillowcases	X	2
	Towels	X	3 or 1
	Diapers & Pads	X	1 (K)
	Personals	X	4
	Delicates	X	4
Food & Beverage chlorine bleach	White (Cotton/Blend) Table Linen	X	3 (E)
	Colored (Cotton/Blend) Table Linen	X	2 (F)
	White (100% Polyester) Table Linen	X	3 (E)
	Colored (100% Polyester) Table Linen	X	2 (F)
	White Chef Coats	X	1 (J)
	Kitchen & Maintenance Rags	X	1 (G)
oxygen bleach	White/Colored (Cotton/Blend) Table Linen	X	3 (H)
	White/Colored (100% Polyester) Table Linen	X	3 (H)
	White Chef Coats	X	1 (G)
	Kitchen & Maintenance Rags	X	1 (G)
Other oxygen bleach	Oxygen Bleach Terry	X	1 (G) or 3 (L)
	Oxygen Bleach Terry (No Iron)	X	1 (G) or 3 (L)
	Open	No	

(A) Switch Position #4 gives 7 minute wash. Flush & Prewash eliminated with jumper (connect orange/white wire to terminal strip #2).

(B) Flush & Prewash eliminated with jumper (connect orange/white wire to terminal strip #2).

(C) Switch Position #1 gives 2 flushes/3 rinses after bleach

(D) Switch Position #2 gives either 2 flushes or 0 flushes. Flush & Prewash eliminated with jumper (connect orange/white wire to terminal strip #2).

(E) Switch Position #3 gives 7 minute wash.

(F) Switch Position #2 gives either 2 or 0 flushes with a 7 minute wash. Flush & Prewash eliminated with jumper (connect orange/white wire to terminal strip #2).

(G) Switch Position #1 gives 3 minutes flush/3 min. prewash/7 min. wash/5 rinses

(H) Switch Position #3 gives 7 minute wash/7 minute 2nd rinse

(J) Switch Position #1 gives 3 minute flush/3 min. prewash/7 min. wash

(K) Switch Position #1 gives 2 flushes

(L) Same as (G) only deletes first flush

Please refer to OPL Washer CYCLE TIMES charts for all available options.

T-400 Mounting Dimensions

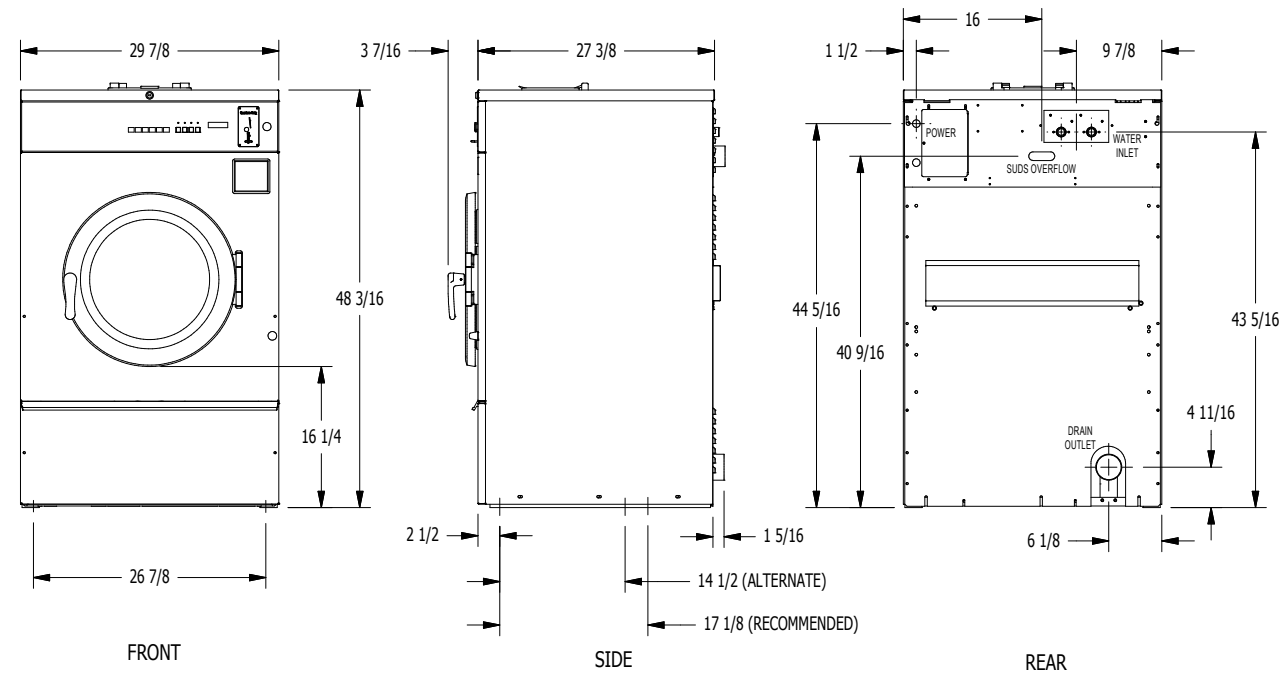

T-400 Mounting Dimensions

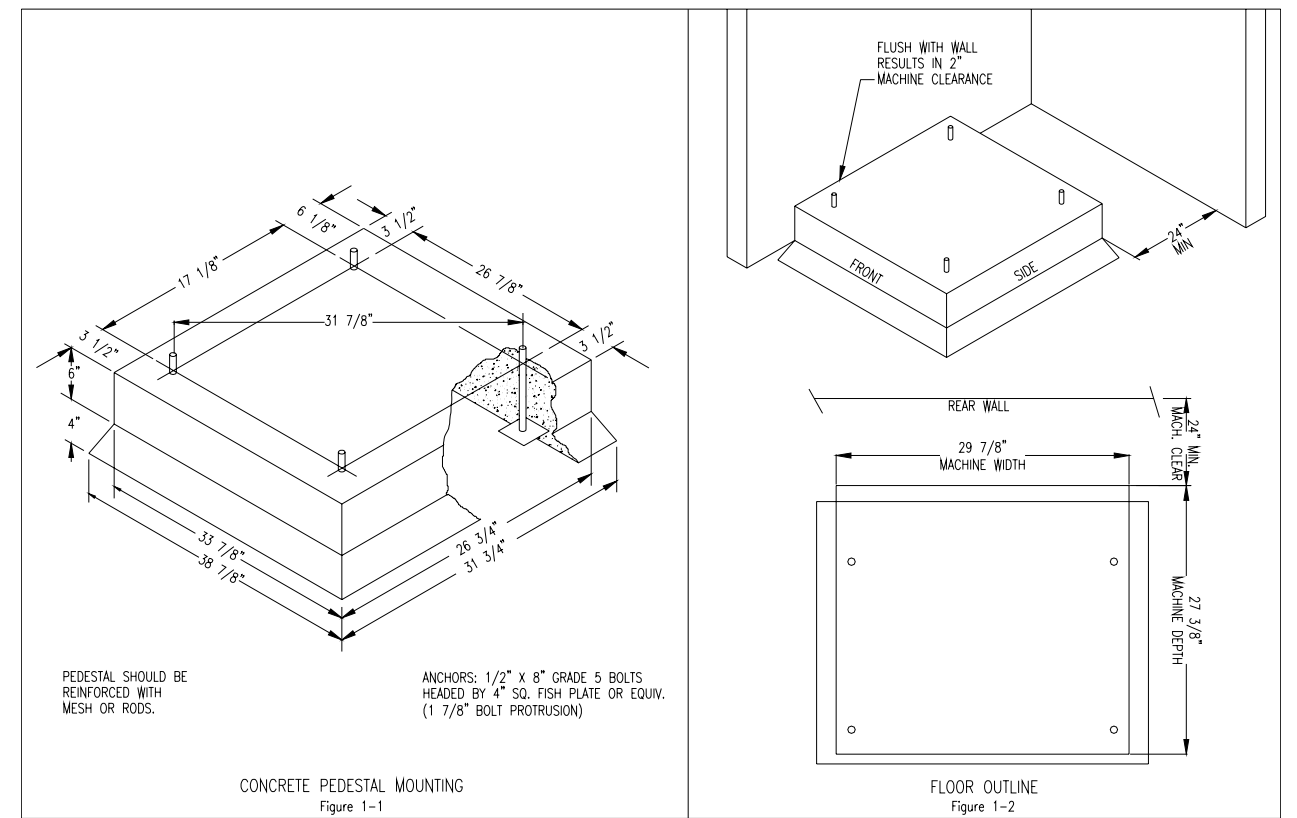

T-600 Mounting Dimensions

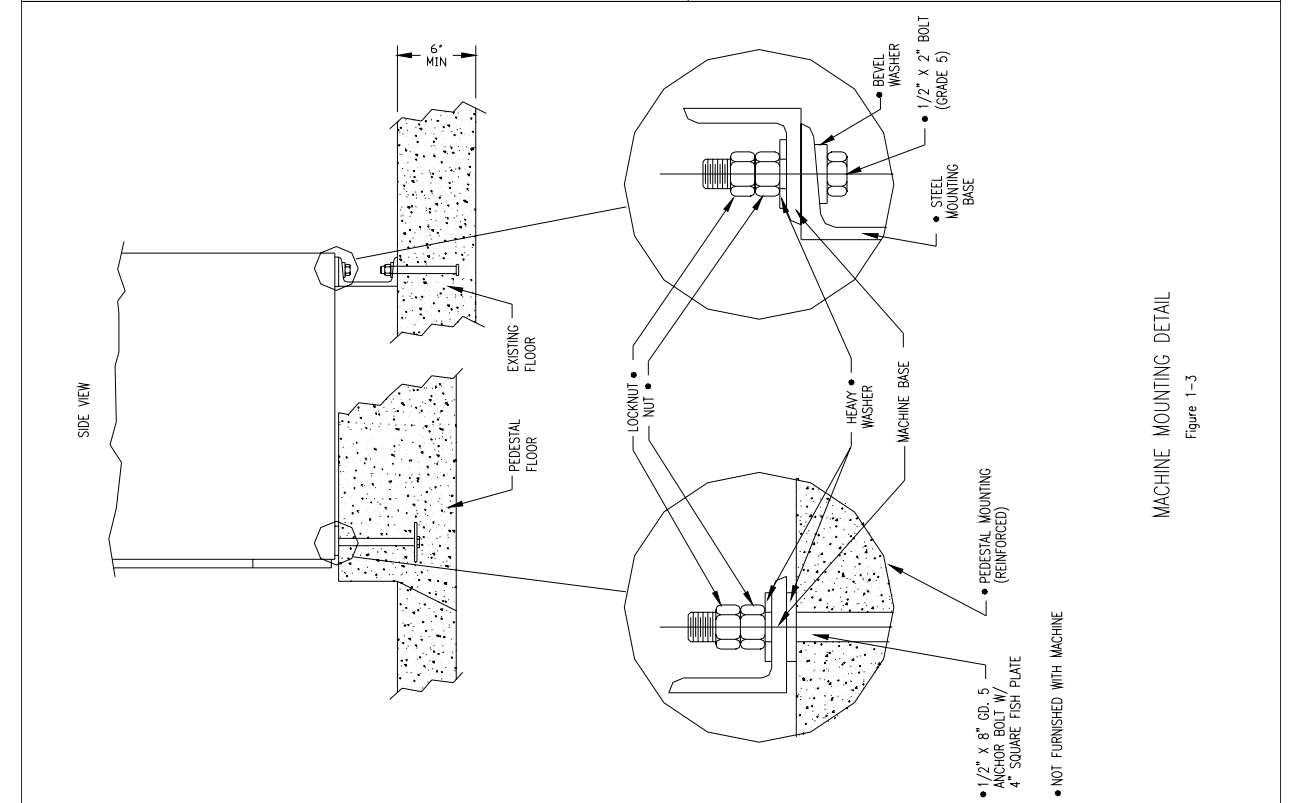
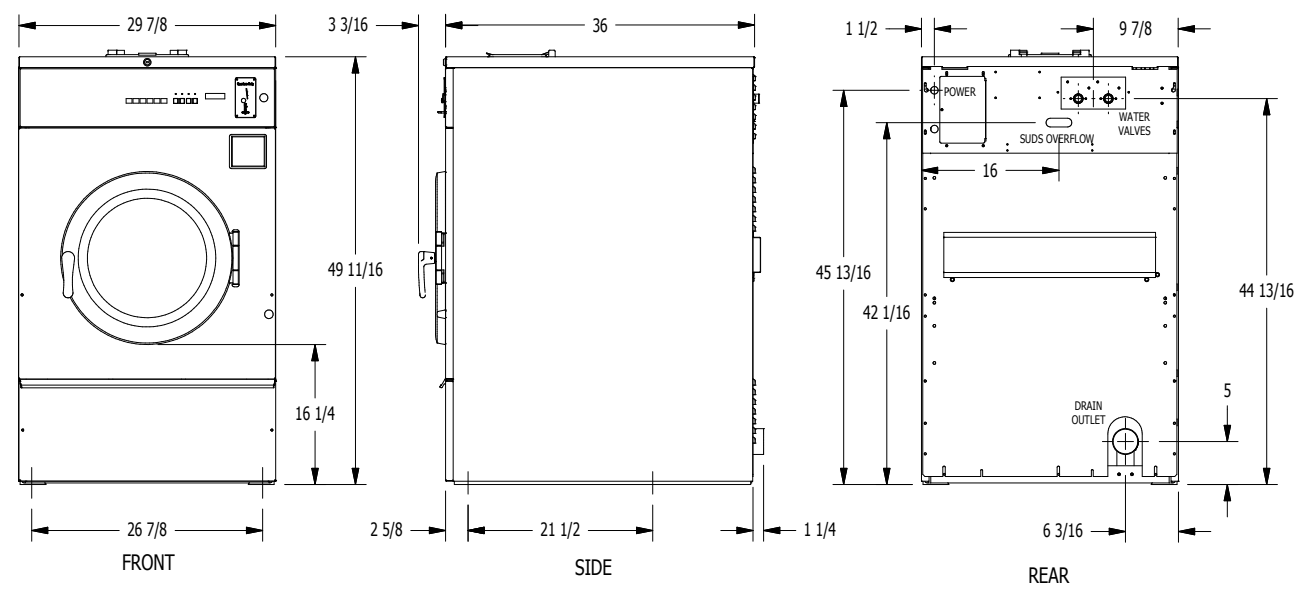

Installation & Operation

All washers must be installed in accordance with all local, state and national building, electrical, and plumbing codes in effect in the area.

Foundation Requirements

The washer must be securely bolted to a substantial concrete floor, or mounted upon a suitable base which is in turn securely bolted to a substantial concrete floor. Care must be stressed with all foundation work to insure a stable unit, eliminating vibration. All installations must be made on sound concrete floors. See mounting dimensions for each model being installed.

Mounting

A concrete pad or steel base which elevates the machine 4 to 6 inches above the floor level. To provide easy access to the loading door, it is recommended to allow a minimum of 24" of clearance behind the rear of the machine for service as is shown. Dexter highly recommends the use of a dry expansion grout mix.

Proper Machine Grout Installation

Grout should be installed between base (if used) and concrete floor on all side rails and crossmembers. If using a base you should grout between base top and machine frame and all side rails and crossmembers.

Mounting Holes

See mounting dimensions for the machine model you are installing in previous section. They also show a typical concrete pad arrangement. It is highly recommended that you use all mounting holes supplied with each model. Note: Mounting bolts should be checked frequently to insure that they remain tight. The machine should be checked with a spinning load to be sure there is no unusual vibration or movement between the machine and the base or floor. Please note: Machine grouting is highly recommended as grouting insures stability and longevity.

Plumbing

Water supply hoses are furnished with each machine. The threaded connections on the hoses are standard garden hose type thread. Separate hot and cold water lines with shut off valves or faucets for inlet hose connections must be provided, maintaining 30 to 120 p.s.i. water flow pressure. Maximum water temperature is 180 degrees.

Drain

The drain outlet tube at the rear of the machine is 3" in outside diameter on models T-400 & T-600. The drain outlet tube at the rear of the machine is 2 1/4" outside diameter on a T-300. All Drains are gravity Drain. Adequate fall must be maintained for proper drainage.

Protective Film

The machine may have protective adhesive film on the front escutcheon area and the front and side stainless steel panels. The film may be peeled off before putting the machine into service.

Electrical

Dexter single/three-phase 208-240VAC 60 Hz washing machines are intended to be permanently installed appliances. No power cord is provided. The machine should be connected to an individual branch circuit not shared by lighting or other equipment. The connection should be sheathed in liquid tight flexible conduit, or equivalent, with conductors of the proper size and insulation. A qualified technician should make such connections in accordance with the wiring diagram.

Each unit should be connected to an individual branch circuit not shared by lighting or other equipment. Conductors of the proper size and insulation (suggested size on the next page) should be used.

Electrical power connections are made to the small terminal block located in the rear of the control trough. The terminal block is accessed by opening the top panel of the machine.

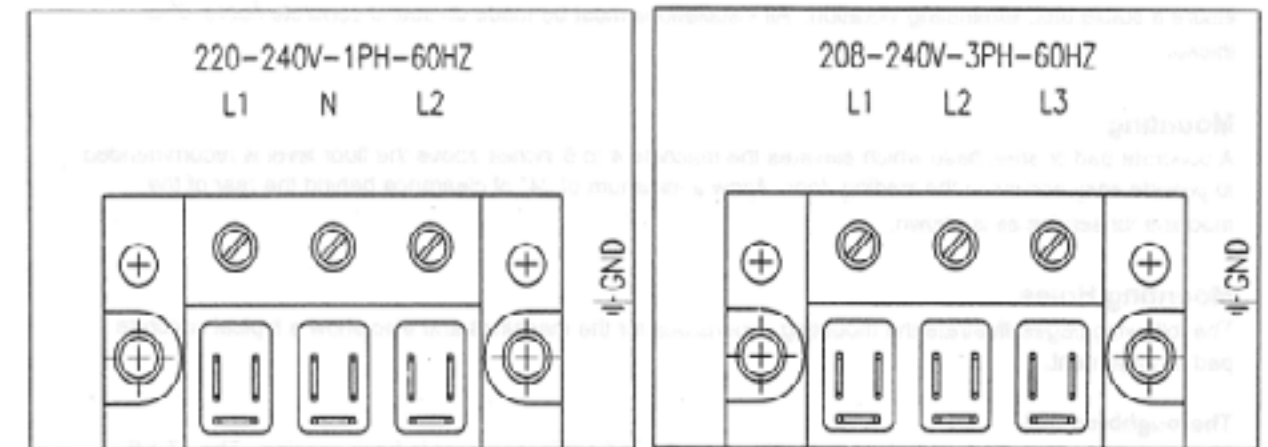

1 Phase
220-240 volts, 60 Hz.
3 wire plus ground

3 Phase
208-240 volts, 60 Hz.
3 wire plus ground

Suggested Minimum Wire Size --12 Ga.

Fusing Requirements

Dual element time delay fuse or equivalent breaker of amperage specified below.

1 Phase	20 amp
3 Phase	15 amp

Always disconnect electrical power to the machine before performing any adjustments or service work.

Rotation in extract as viewed from front of washer looking towards rear will be counterclockwise.

Liquid Chemical Injection

In the left rear corner of the washer is the chemical injection assembly. This is where all chemical hose connections are made. The chemical hoses should be inserted into the round PVC pipe a minimum of 8" and a maximum of 12" on the T-400 and a minimum of 14" and a maximum of 18" on the T-600 to eliminate chemical buildup in the pipe and/or restrict water flow to the tub.

Final Check Out

After all mounting, plumbing, and electrical work is completed, the washer should be run through the a cycle and checked for water leaks and proper functioning. Note: Three Phase Machines - Spin must be counter-clockwise viewed from the front of the machine. If spin is clockwise, the power wires going to L1 and L2 on the power terminal block TB-1 should be switched.



WARNING

Always disconnect electrical power to the machine before performing any adjustments or service.

Section 3:

Electrical Wiring Diagrams & Schematics

Electrical Path Circuit Schematics

Start Circuit

Power travels into the control trough on L1 & L2 (3 phase) or L1 & N (1 phase). On 3 phase, 240VAC goes to a Control Transformer that steps the voltage down to 120VAC AC for the controls. 120VAC then travels to the On/Off Switch. If On is selected 120VAC travels to the 1.5 amp Circuit Breaker. On 1 phase, 120VAC goes directly to the On/Off Switch and then to the 1.5 amp Circuit Breaker. There is no need for a step down transformer on 1 phase.

From the Circuit Breaker, 120VAC travels on the white/red wire to the Main Timer Start and On-Off Contacts. The Start Contact is closed before the machine has been started so 120VAC travels through the Start Contact and is supplied to the Advance/Start Switch. When the Advance/Start Switch is closed 120VAC is supplied on the orange/white wire to the Rapid Advance Timer Motor. This timer motor starts advancing the Main Timer to the preselected starting position. The On-Off Contact in the Main Timer closes and provides 120VAC to the S1 Door Switch. The On-Off Contact also provides 120VAC to the On Light on the red wire. With the S1 Switch closed (door is latched) the Door Lock Solenoid is now powered with 120VAC via the white/red wire. The Door Lock Solenoid pulls in, locking the door and closing the S2 and S3 switches. The S2 Switch is a backup to the S1 Switch so that the adjustment on S1 isn't as critical. The S3 Switch provides 120VAC to Timer Contacts RA-1,2,3,4 to power the Rapid Advance Motor again (if 2 Flushes are not selected) and the Main Timer is allowed to advance on to the preselected start position. The blue wire furnishes the neutral for the controls.

Fill Circuit-Warm

120VAC is supplied to the controls through the S1, S2, and S3 Door Switches. The On Light and the Door Lock Solenoid (discussed in Start Circuit) will remain on throughout the cycle. The Lock Thermoactuator Contact in the Main Timer is closed and provides the neutral side to operate the Lock Thermoactuator. This contact cycles open and closed keeping the Lock Thermoactuator activated until 1 1/2 minutes before the end of the cycle. At this point the contact opens and removes power to the Lock Thermoactuator. 120VAC is provided to the Lock Thermoactuator on the orange wire from the S3 Door Switch. The Drain Contact in the Main Timer is closed and provides 120VAC to the Drain Valve on the brown/yellow wire which closes the valve. The Wash Motor Contact in the Main Timer is closed and provides 120VAC to the Reversing Timer and the Reversing Timer Motor on the blue/black wire. This will start the Reversing Timer operating which will alternately open and close the Micro Switches that provide the direction of tumble for the wash basket Depending on the cycle selected either the Wash Light Contact, the Prewash Light Contact, or No Contact (1st Flush) in the Main Timer is closed and provides 120VAC to these Lights. The orange wire coming from the S3 Door Switch provides power to the Wash Water Contact in the Main Timer as well as the High Water Level Contact. 120VAC connects from the Wash Water Contact to the Wash Temperature Contact via an internal timer connection.

Now a water temperature must be selected with the Temperature Selector Switch. We'll use #2 Warm. The washer fills the tub through the back of the machine with both the C1 Cold and H1 Hot Water Valves. 120VAC travels from the Wash Water Timer Contact to the #1 Contact in the Selector Switch via the white/black wire. 120VAC goes through the closed #1 Contact in the Selector Switch and energizes the C1 Cold Water Valve Solenoid via the white/orange wire. 120VAC also travels to the closed #4 Contact in the Selector Switch. This closed contact provides power to the H1 Hot Water Valve Solenoid via the red/yellow wire. The neutral for the Water Valves & Main Timer Motor is provided through the Pause/Run Switch & through the Motor Overload Protector. The Main Timer is stopped until the Pressure Switch provides neutral when low level is reached.

As the washer fills with water, the Wash Basket will tumble one direction for 19 seconds, pause, and then reverse direction for 19 seconds. All Flushes and Rinse 1, 3 & 4 are high level. Wash, Rinse 2 & Final Rinse

are low level. For a high level bath 120VAC travels from the timer High Water Level Contact on the green/white wire to the R4 High Water Level Relay. When energized, the R4 High Water Level Relay opens the neutral yellow wire from the low level side of the Pressure Switch & closes the violet/yellow from the high side. When the water reaches the predetermined level the Pressure Switch moves to the full position and opens the neutral side of the line to the Water Valves. This shuts the Water Valves off.

Wash Circuit

As the washer fills the tub through the back of the machine with either one or both the C1 Cold and H1 Hot Water Valves, the Wash Basket will tumble one direction for 19 seconds, pause, and then reverse direction for 19 seconds. This is accomplished through the use of a Reversing Timer. 120VAC is supplied to the Reversing Timer Motor on the blue/black wire from the Wash Motor Timer Contact in the Main Timer. The Reversing Timer will alternately open and close the two Wash Micro Switches and provide 120VAC to the R1A (brown/white wire) and R1B (orange/green wire) Wash Contactor Coils. These coils open and close the Contactor Switches to operate the Drive Motor.

As discussed in Start and Fill, the Lock Thermoactuator, Drain Valve, On Light, and Main Timer Motor (except in fill) are all operating throughout the Wash Cycle.

Liquid Chemicals Injection Pumps receive 120 volt signals from the terminal strip on the back of the washer. These are labeled A, B, C, & D. (A-Prewash, 8-Wash, C-Rinse 2, D-Final Rinse)

Drain, Rinse 1 & 2, 3, 4, and Final Rinse Circuit

The Drain Contact on the Main Timer opens removing power to the Drain Valve. The normally-open spring-loaded Drain Valve opens and empties the tub.

For Rinse 2, 3 & 4 the Rinse Light Contact in the Main Timer closes and provides 120VAC to the Rinse light. The Rinse Water Contact in the Main Timer also closes and provides 120VAC to the C1 Cold Water Solenoid and through the Rinse Temp Contact to the H1 Hot Water Solenoid (Except when cold #4 is selected). The tub will fill until the predetermined level is achieved at which time the Pressure Switch Contact will open the neutral side of the line shutting off the C1 Cold Water Solenoid and H1 Hot Water Solenoid.

For the Final Rinse, the Final Rinse light Contact in the Main Timer closes and provides 120VAC to the Final Rinse Light. Rinse water is the same as in Rinses above.

The Hot Rinse Contact provides 120VAC to the R5 relay on the brown/red wire. This opens the circuit to the C1 Cold Water Solenoid when Temperature Selector Switch #1 or #2 is depressed.

Extract Circuit

The Wash Motor Contact remains closed and provides 120VAC to the closed Clockwise Micro Switch on the Reversing Timer. 120VAC is then fed to the Counter Clockwise Micro Switch via a jumper wire. Power is then sent through the Counter Clockwise Micro Switch to the Delay Spin Micro Switch. The Delay Spin Micro Switch provides 120VAC to the Spin Motor Contact in the Main Timer on the blue/white wire. The Spin Motor Contact is closed for spin and the voltage continues on to the R2 Spin Motor Contactor Coil on the red/black wire and to the Spin Light on the yellow/red wire. With 120VAC to the R2 Spin Motor Contactor Coil the Contactor is pulled down (closed) and two things happen. With the R2 Contactor closed, 120VAC is now provided from the orange wire directly to the Contactor eliminating the Reversing Timer and the Micro Switches from the circuit.

The second thing that happens when the R2 Contactor is closed is that voltage is provided directly to the Spin Winding in the motor on 3 phase machines and the washer spins.

On 1 phase washers, the R2 Contactor provides 120VAC to the Main Spin Winding and also provides 120VAC to the Solid State Start Switch Terminal #2. 120VAC goes out of the Solid State Start Switch on the #3 Terminal to the Spin Capacitor. The Spin Capacitor then provides 120VAC to the Phase Spin Winding until the Spin Motor comes up to speed. Within a few seconds of start up, the Solid State Start Switch senses that the Spin Motor Current has dropped (motor is up to speed) and opens the circuit on #3 Terminal on the Solid State Start Switch. This eliminates voltage to the phase winding (start winding) and the motor continues to run on the Main Winding.

Unlock Thermoactuator and Shake Out Circuit

The Lock Thermoactuator Contact in the Main Timer opens 1 1/2 minutes before the end of the cycle removing the neutral to the Thermoactuator. This allows the Thermoactuator time to retract by the end of the cycle.

To ensure that the Lock Thermoactuator has retracted by the end of the cycle, 1 minute prior to the end of the cycle, the Unlock Thermoactuator is powered with 120VAC through the Unlock Thermoactuator Contact in the Main Timer.

The Spin Motor Contact in the Main Timer opens, stopping voltage to the motor. The basket will coast to a stop. The Wash Motor Contact in the Main Timer closes providing power to the Reversing Timer once again (discussed in Wash Cycle). The washer will tumble for approximately 30 seconds to let the clothes shake loose and then stop.

The neutral for the Main Timer Motor is provided through the Delay Fill Timer Contact.

End of Cycle Circuit

The On-Off Contact in the Main Timer opens removing power to the Door Lock Switches and Contactors. The machine is now stopped. The Start Contact on the Main Timer is closed providing 120VAC to the Advance/Start Switch on the white/green wire. The machine is now ready to start a new cycle.

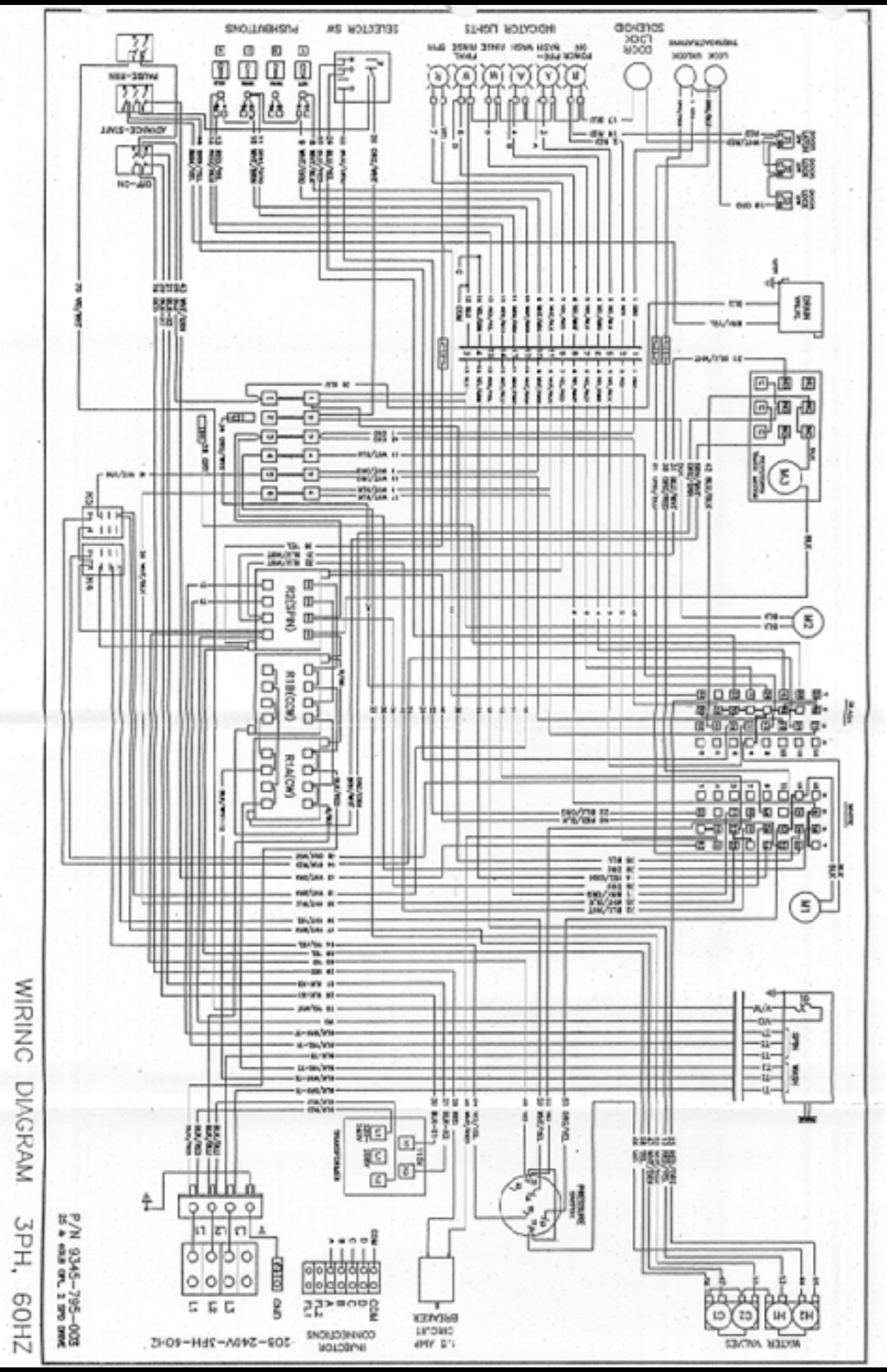

WIRING DIAGRAM 3PH, 60HZ

P/N 9345-795-005
 25 A 600V CUL 1 500 DRIVE

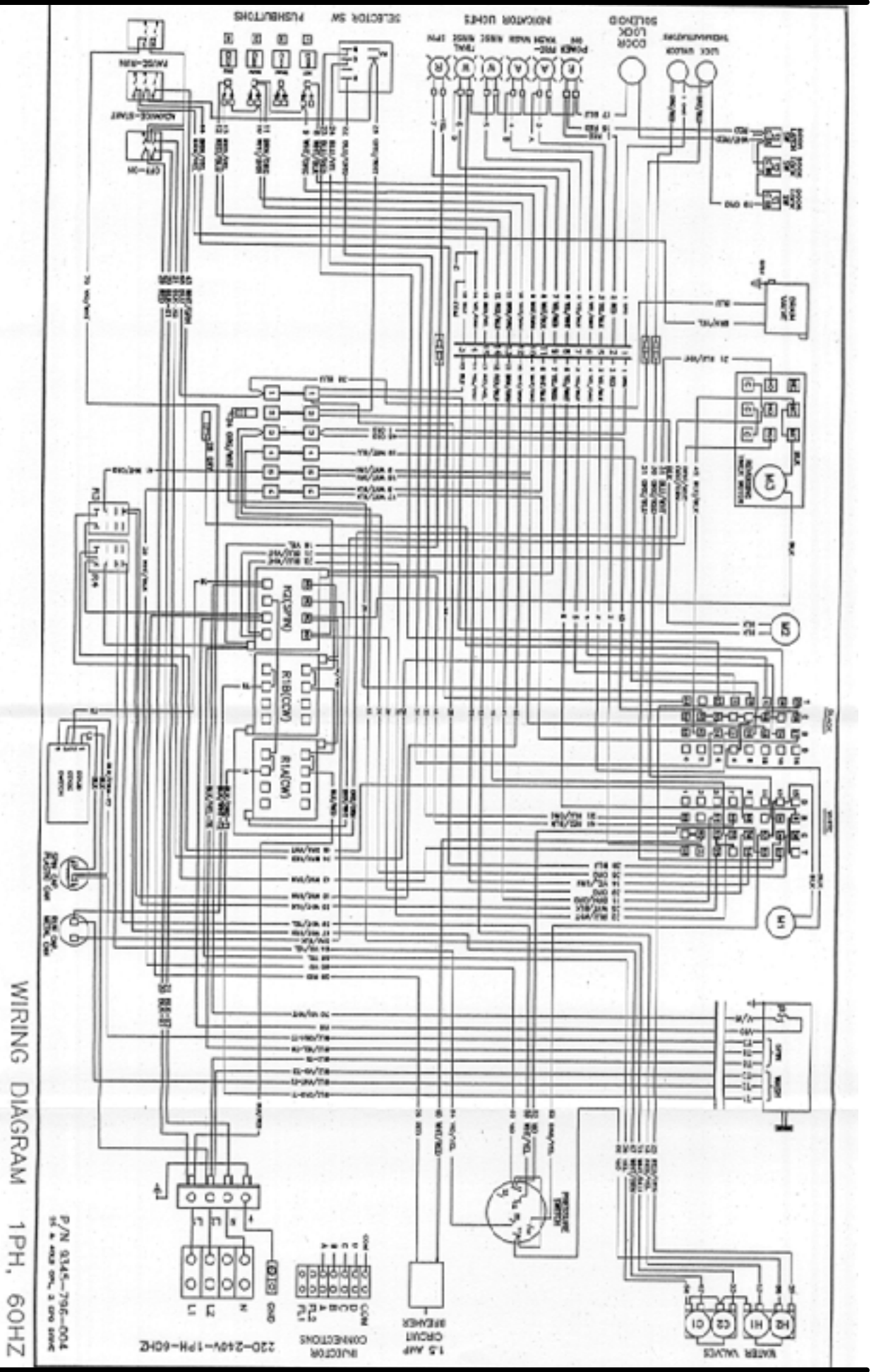

WIRING DIAGRAM 1PH, 60HZ

P/N 9345-796-004
 25 A 600V CUL 1 500 DRIVE

P/N 9345-783-001
 25 W 40LB OPL, 2 SPCL GRNE
 55LB OPL, VF DRIVE

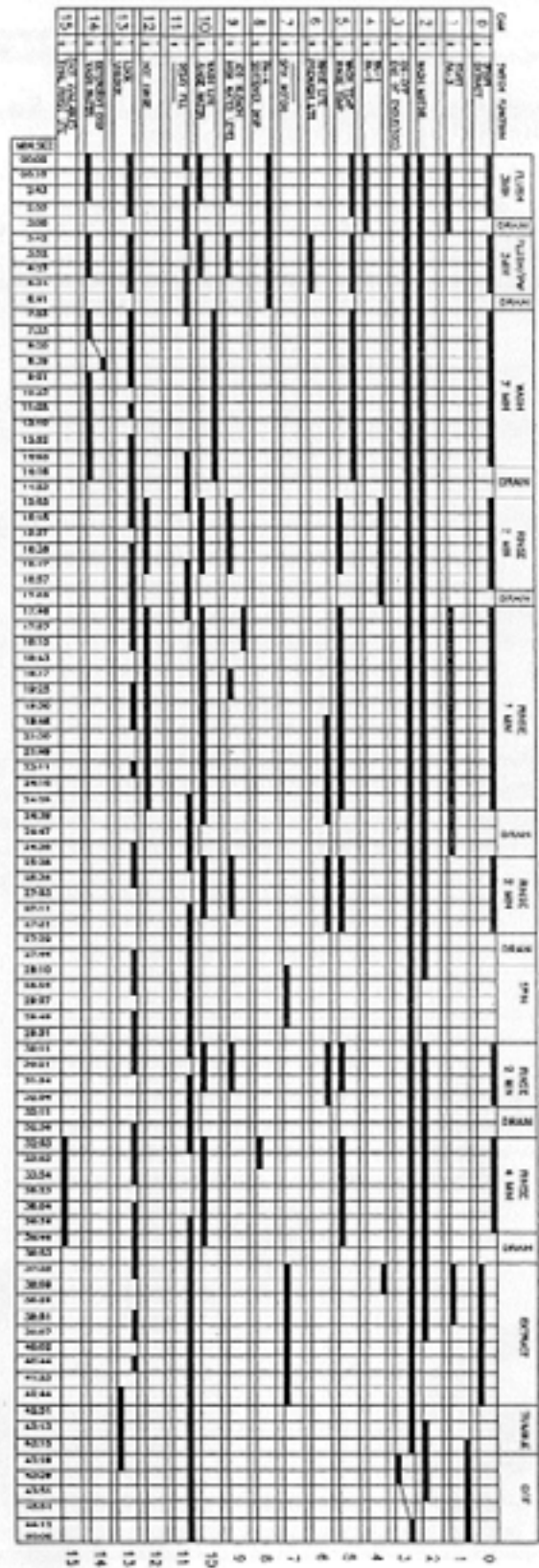

Section 4:

Machine Service Procedures

Top Panel Removal

- Step 1:** Remove 4 screws that hold detergent dispenser to top panel.
- Step 2:** Unlock top panel lock.
- Step 3:** Raise top panel, slide to the rear to release from back clips and lift off.

Front Panel Removal

- Step 1:** Remove 2 screws between front panel top and front (located behind control panel).
- Step 2:** Remove the two screws in the middle of the front panel.
- Step 3:** Pull panel out at the bottom to about a 45 degree angle to detach the top lip and remove.

Back Panel Removal

- Step 1:** Remove all screws holding back panel in position except the bottom row.
- Step 2:** The bottom row of screws are slotted and only need to be loosened and to lift off panel.

NOTE: The back panel is not only a safety requirement but also contributes to the rigidity of the cabinet.

Drain Valve Access

For access to drain valve, remove lower service panel. The drain valve is a ball type and is powered closed by the drain valve motor. It is mounted under the washer tub on the left side. It is spring loaded open. If power is interrupted to the washer, the motor releases the sealing ball, allowing the drive spring to open the valve. With the valve open, all water in the washer will drain out.

Drain Valve Cleaning

- Step 1:** Loosen the clamp on the tub hose at the drain valve end and remove the hose from the drain valve.
- Step 2:** Loosen the drain hose clamp on the back of the drain valve. Remove two drain valve mounting racket screws from the frame of the washer.
- Step 3:** Remove the drain valve and bracket assembly.
- Step 4:** Unplug the wiring after the drain valve is removed from the washer.

Chemical Injection Assembly

In the left rear corner of the washer is the chemical injection assembly. This is where all chemical hose connections are made.

Detergent Dispenser

Remove top panel to access dispenser. (see Removing Top Panel) Detergent is flushed from the front of the compartment and fabric softener is flushed from the back. There will be a small amount of water left in the fabric softener compartment after each use.

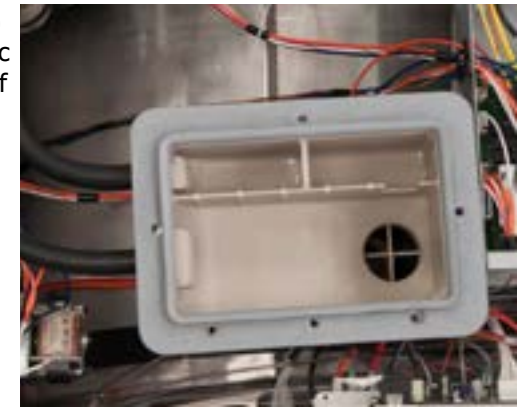

Vacuum Breaker (also called an air gap)

In the left rear of the cabinet is the vacuum breaker. It guides the water to the tub and dispenser and prevents a back flow of water.



Water Valves

Remove top panel to access water valves. (see Removing Top Panel) The two dual outlet water valves are mounted to the water valve mounting plate that is fastened to the rear channel. To remove the valves, loosen the 2 locking nuts on both sides of the mounting plate from the interior of the machine and then lift the plate and valves off of the back channel and pull the assembly into the machine. The valves can then be removed from the mounting plate by removing the 5/16 mounting screws.

Always check inlet screens to be sure that they are clean. Disassembly requires the removal of two solenoid screws and three valve body screws. Below the solenoid coil is a solenoid guide, armature, armature spring and diaphragm. All valve parts are available individually or as a complete unit.

Masking Ring (door lock cover) Removal

- A. Remove front panel.
- B. Remove nuts that retain masking ring.
- C. Move it to the left and off.



Door Lock Assembly Operation

After loading the clothing, the door should be closed and latched. The locking cam on the door contacts the latching switch actuator which closes the latching switch. The specified number of coins should now be added to start the washer. The gear motor pulls up on the locking pawl by use of a linkage rod. The locking pawl has two jobs. The first is to lock the door. This is accomplished by blocking the locking cam on the door so that it can't rotate to unlock. The second job is to close the two piggyback lock sensing switches. These switches control power to all of the controls. If the door unlocks for any reason, these two switches will stop the machine. When the door handle is 1/4 to 1/2 of an inch from its fully closed position, the latching switch should close. The two piggyback lock sensing switches should be open when the door is unlocked and should be closed when the door is locked.

Accessing the Door Lock Assembly

After removing the front panel and masking ring, the door lock assembly can now be accessed.

Adjustment for Door Lock Assembly

The latching switch and the piggyback lock sensing switches all have slotted mounting for easy adjustment.

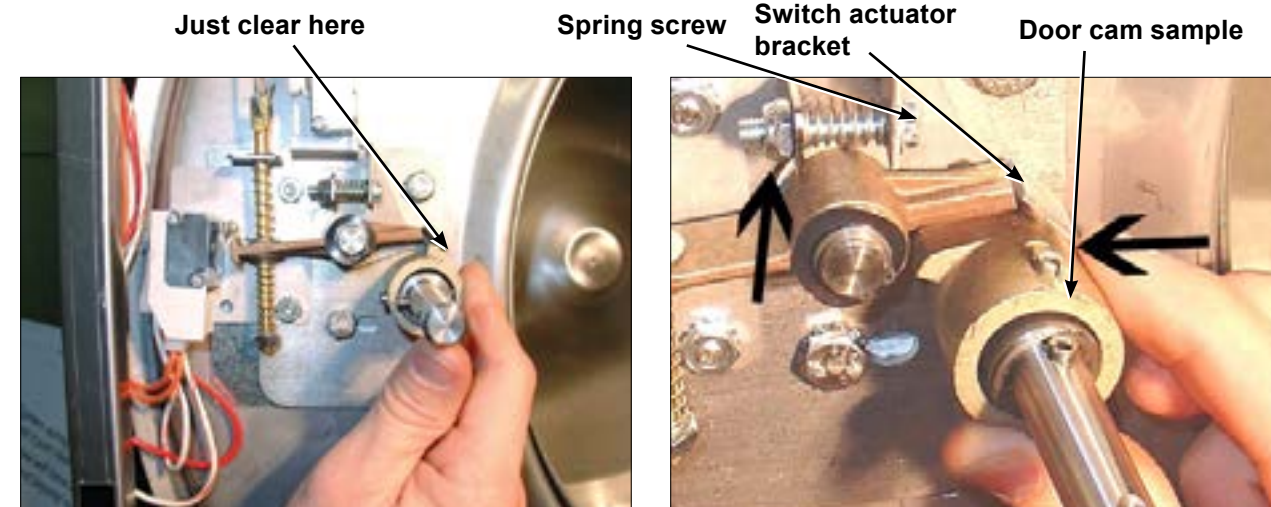

Step 1: Set door cam over pin. Here you can see the door cam away from the door lock assembly.

Step 2: Tighten spring screw on switch actuator bracket arm until it just clears cam OD. at base of door lock assembly.

Adjustment to this bracket usually is not necessary as next step is used more in field.

Flat blade screw on door switch latching



Step 3: With switch actuator bracket adjusted you will now need to adjust single switch by loosening 2 flat brade screws and allowing swivel of switch. Move switch towards above bracket until it actuates. Now tighten flat blade screws. Use a .040 thickness guage to insert between bracket and switch and the switch should close and open again upon removal of thickness guage.

Door cam check position

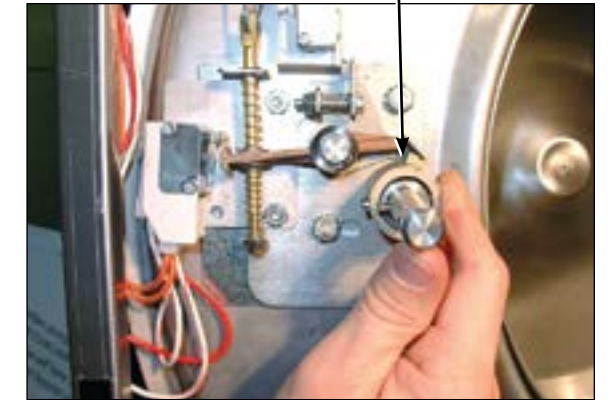

Step 4: Check for switch actuation at partial turn of cam as in operation above. Door handle goes from horizontal to six o'clock vertical.

Door lock rod Locking pawl blocking

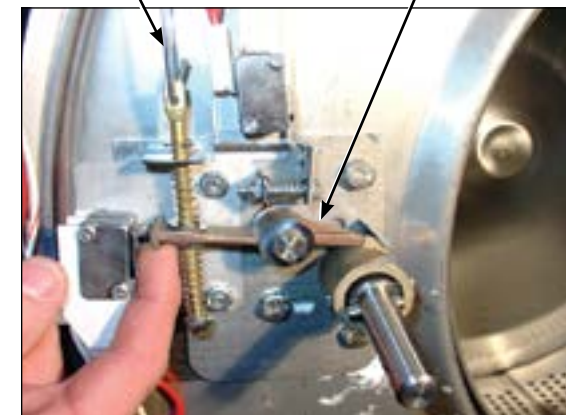

Step 5: Check that lock pawl arm swings to cam lobe to lock position.

Adjustment screw for (piggyback switches)

Top flat end of locking pawl.

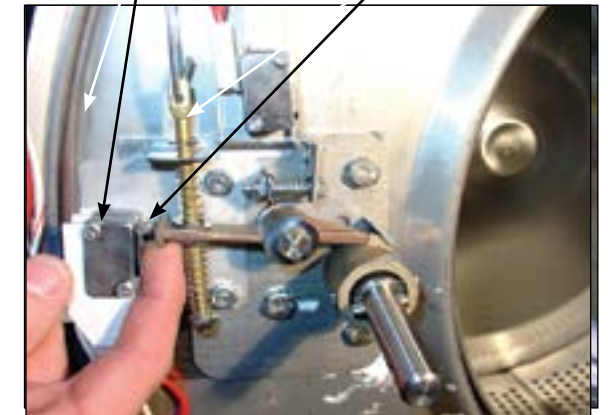

Step 6: The lock stacked switches (piggyback) must be adjusted as door lock solenoid pulls up on door rod and locking pawl is now blocking door cam from turning and is in full up position. The stacked switches (piggyback) have a single actuator arm and it must actuate when single actuator roller wheel rolls to flat side of locking pawl. You will also notice a .040 gap between actuator arm and switch bodies.

Note: Both stacked switches must operate together!

Door Locking Solenoid

The door locking solenoid is powered shut with control voltage to lock the door and releases when voltage is removed. It is located in the left front corner of the washer.

Thermoactuators

The thermoactuators are a safety device that keeps the door from immediately unlocking if power is lost while the machine is operating. They are mounted under the door locking solenoid.

Lock Thermoactuator

Control voltage is applied to the lock thermoactuator at the beginning of the cycle making it extend and block the door locking solenoid. This keeps the door locked for approximately two minutes after a power failure occurs. The lock thermoactuator does not delay the door opening at the end of a normal cycle.

Unlock Thermoactuator

To ensure that the lock thermoactuator has retracted by the end of the cycle, one minute prior to the end of the cycle, the unlock thermoactuator is powered with control voltage making it extend and unblock the door locking solenoid.

Loading Door Removal

- A. Support door to prevent dropping.
- B. Remove 3 bolts holding hinge retainer and set door off.

Loading Door Disassembly

- A. Remove the loading door as outlined above.
- B. Lay the door on a flat surface with the glass down.
- C. While holding down on the door glass, lift up on the door ring and roll back the lip of the gasket with your fingers.
- D. Work all the way around the gasket and the glass is out.

Loading Door Reassembly

- A. Lay the door ring face down on a flat surface.
- B. Start the glass into one side of the door. gasket.
- C. Use one hand underneath to push the gasket out and the other hand on the top pulling the gasket in place.
- D. The front lip of the door gasket should be checked for proper seating.

Loading Door Adjustment

The door can be adjusted by changing the number of shims behind the door hinge and the door lock assembly. The vertical fit of the door to the tub can be altered by loosening the door hinge bolts and raising or lowering the door before retightening. It is important for the door to be centered on the tub front. By chalking the nose of the tub and closing the door to transfer that line to the gasket, the centering can be evaluated. It is also important for door pressure to be similar around the door perimeter. Door pressure can be evaluated by inserting a dollar bill in several positions and tugging on it. See Parts Section for kit to increase door sealing pressure.

Loading Door Hinge Removal

- A. First remove loading door, front panel, and trim ring.
- B. Remove 3 screws holding door hinge. Shims may be present between hinge and tub front. The number may be increased or decreased to adjust right side door pressure.

NOTE: Door hinge mounting bolts penetrate tub front and require silicone sealer applied to holes when reinstalling.

Control Panel Name Plate Decal

The name plate on washer front is adhesive backed.

Control Panel Name Plate Removal

The name plate may be removed by simply peeling it off.

Re-Installation of Name Plate

Step 1: Remove any remaining glue from the control panel.

Step 2: Before removing the paper backing from the name plate, check fit to the control panel. The program push buttons are the locating guides.

Step 3: Remove the paper backing from the right side of the name plate, position it on the panel and press right end into place. Peel the backing from the left end and press into place.

Motor Relays

These relays are in the center of the control trough. The front relay is for spin. The other two are wash relays. The middle one is for counter-clockwise direction and the back one is for clockwise direction. Wires are removed using a straight blade screwdriver. The relays are removed by prying out on the mounting tab at the bottom of the relay with a straight blade screwdriver.

R1A Wash Motor Relay (clockwise)

The R1A Wash Motor Relay is mounted behind the R1B wash motor relay. The 120VAC coil on the wash relay is energized by the clockwise-wash micro switch in the reversing timer. The coil opens and closes the relay switches to operate the drive motor.

R1B Wash Motor Relay (counter-clockwise)

The R1B Wash Motor Relay is mounted behind the R2 spin motor relay. The 120VAC coil on the wash relay is energized by the counter-clockwise wash micro switch in the reversing timer. The coil opens and closes the relay switches to operate the drive motor.

R2 Spin Motor Relay

The R2 Spin Motor Relay is mounted in front of the R1B wash motor relay. The 120VAC coil on the spin relay is energized when the delay-spin micro switch in the reversing timer sends 120VAC to the spin motor contact in the timer. The coil opens and closes the relay switches to operate the drive motor.

Program Timer

This timer is located on the left side of the control trough directly behind the reversing timer and is held in place with two screws. It controls most machine functions. There are two drive motors on the program timer. The one towards the front of the machine advances the timer at the beginning of the cycle. The timer motor towards the rear drives the timer throughout the cycle. These two motors can be replaced individually. The program timer has a black knob that allows the timer to be manually turned to any portion of the cycle for diagnostic purposes.

Note: All single phase 251b. and 401b. washers have an electronic start switch and run and start capacitors. Three phase machines do not require these parts. ALWAYS DISCHARGE CAPACITORS BEFORE SERVICING.

Solid State Start Switch

This switch is located on the right side of the control trough directly behind the coin accumulator transformer. Its job is to switch the spin start capacitor on at the beginning of spin and to switch the spin start capacitor off when the motor achieves operating speed. To test the electronic start switch, clamp an ammeter around either single lead wire to the start capacitor (capacitor with plastic case). The switch should show starting current flow in the capacitor circuit momentarily at the start of spin. Continuous current flow means that the electronic start switch is stuck on and has failed. No current flow means that the switch is open and has failed.

Capacitors

The capacitors are located in the right rear corner of the control trough directly behind the start switch. The capacitor with the metal case is the wash run capacitor and the capacitor with the plastic case is the spin start capacitor.

Controls Transformer

This transformer is mounted at the back of the control trough and steps a range of 208 to 240 volts down to 115 volts for the controls. There are two terminals on the control transformer for incoming power. One terminal is for 208 to 220 volts and the other is for 221 to 240 volts.

Pressure Switch

The pressure switch sets the water level in the washer and is located in the left rear corner of the control trough. As the water level rises, it compresses the air in the pressure switch hose. When the washer reaches the desired water level, the compressed air in the pressure switch hose opens the contacts in the switch, shutting off the water. When at the empty level, the pressure switch contacts are closed allowing the machine to either spin or fill with water. At low level the water will be approximately 1/2" up from the bottom of the door glass. On high level the water will be approximately 3"-4" up from the bottom of the door. The pressure switch is sealed and is not adjustable.

Power Connection Terminal Block

This terminal block sets at the very back of the control trough. Incoming power to the washer should connect here. (see Electrical under Installation and Operation Section for exact connections)

Cycle Indicator lights

The 120VAC indicator lights are mounted to the back of the control panel and are held in place with two tabs. They are removed by squeezing the tabs with a screw driver. The lights are replaced as a complete unit.

Temperature Selector Switch

The selector switch is mounted in the center of the control panel and is held in place with two nuts. It allows the selection of hot, warm or cold water temperatures.

Note: Do not over tighten on reinstallation as the switch can be damaged.

Lower Service Panel Removal

Remove 2 screws and pull forward to disengage from the locator studs.

Drive Belt Removal

Turn the drive belt(s) off the basket pulley first and then remove from the motor pulley.

Reverse this procedure for installation.

Note: The T-400 and T-600 have two belts that should be replaced in pairs.

Control Mounting Trough

Remove top panel to access control trough. (See Removing Top Panel) It sets on the right side of the machine and holds many of the controls.

Rocker Switches

These switches can be replaced individually by squeezing the tabs on the back side and pressing them out the front of the panel.

A. Top switch is red and controls Off and On. This switch must be in the on position for the washer to operate. The off position will cause the washer to stop in the cycle and drain the water.

B. Middle switch is white and controls Advance and Start. This switch must be held in the start position momentarily to start a cycle. Wash and rinse baths can be advanced through by holding the switch in the advance position.

C. Bottom switch is blue and controls Pause and Run. This switch must be in the run position for the washer to advance through the cycle. The washer can be stalled. at any point during the cycle for extended soaks by selecting pause. The door will remain locked and the drain valve will remain closed keeping the water in the tub.

Reversing Timer

The reversing timer operates the wash and spin relays and is mounted on the left side of the control trough and retained with two screws. It has three cam operated switches. Two switches operate the Wash cycle by alternately engaging the wash relays to tumble counter-clockwise for 19 seconds, stop for 3seconds, reverse direction and tumble clockwise for j 9 seconds. The third switch engages the spin relay for the high speed spin portions of the cycle.



Drive Belt

Outer Cabinet Removal

T-400 & T-600

Removal of Cabinet T-400 & T-600

- Step 1:** The power supply, water hoses, and drain connection must all be disconnected before proceeding with the disassembly.
- Step 2:** Now remove the lower service panel and the top panel assembly.
- Step 3:** Remove the left and right lower front panel screws that retain the panel to the chassis.
- Step 3:** Remove the bottom row of back panel screws.
- Step 4:** Remove the loading door.
- Step 5:** Remove the screws along the bottom of each side panel. When reinstalling these screws do not overtighten.
- Step 6:** Remove clamp and soap dispenser hose where it attaches to the tub inlet. Disconnect the door lock wires from all switches and the door lock gear motor.
- Step 7:** Disconnect pull rod between gear motor and door lock assembly. Disconnect the wires to the dump valve at the bottom of the machine.
- Step 8:** Disconnect the wires to the drive motor from the VFD T1, T2, T3.
- Step 9:** Remove the clamp and the hose from the vacuum breaker where it connects to the inlet on the back of the tub.
- Step 10:** Remove the pressure switch hose from the bottom of the switch.
- Step 11:** It should now be possible for two people to lift the cabinet up and off of the front of the machine and set it aside.

Outer Tub

Removal

- Step 1:** The outer tub can easily be removed when the tub back, bearing, and cylinder assembly have been removed as outlined.
- Step 2:** At that point only attachments to the chassis are the two front strap mounting bolts.

Reassembly

- Step 1:** Install outer tub in front strap leaving bolts loose.
- Step 2:** Install tub back assembly in washer (see Reassembly of Tub Back, Bearing, and Cylinder (basket) Assembly).
- Step 3:** With tub tback assembly bolted to washer frame and to the back of the outer tub, tighten front strap bolts.

Tub Back, Bearing and Cylinder Assembly

Basket assembly T-400 & T-600

Removal

- Step 1:** Remove the top and back panel as described.
- Step 2:** Move the rear channel, that the water valves mount to, forward by removing the five mounting screws.
- Step 3:** Remove the drive belt.
- Step 4:** Remove the overflow hose, tub fill hose and pressure switch hose from the back of the tub.
- Step 5:** Mark the tub back and bearing assembly for ease in assembly later. (see picture)
- Step 6:** Remove the 12 bolts and nuts from the perimeter of the tub back clamp ring. (Two of the twelve bolts are longer and go through the thicker part of the brace where it connects to the frame.)
- Step 7:** Remove the 2 bolts that fasten the clamp ring to the frame.
- Step 8:** The entire tub back and cylinder assembly may be lifted out of the tub (it may be necessary to break the adhesion of the silicone that seals the tub back to the tub). Blocks should be placed under the edges of the cylinder before setting it down to prevent damage to the cylinder flange.

Reassembly

Reverse the procedures to the left paying attention to the following areas

- Step 1:** Lay the washer on its front. Note: Put a thick pad across the front of the washer, above the door, to protect the handle and coin acceptor.
- Step 2:** Make sure the bearing housing weep holes are located at 12 o'clock and 6 o'clock.
- Step 3:** Clean the silicone rubber from the back of the outer tub and the perimeter of the tub back where the two meet. There is no gasket in this area.
- Step 4:** Apply a new bead of silicone rubber around the back of the outer tub. (see picture)
- Step 5:** Lower the tub back, bearing and cylinder assembly into the washer outer tub.
- Step 6:** Torque all bolts according to the following charts.
- Step 7:** Use a puller to remove the pulley from the shaft.

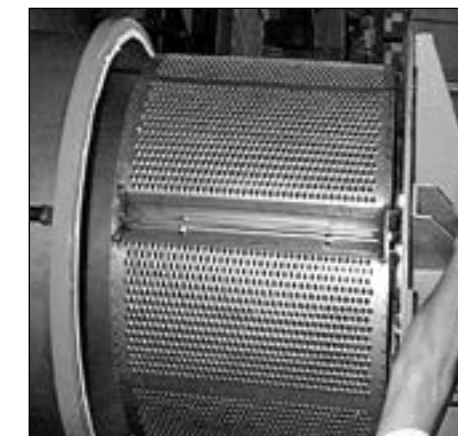
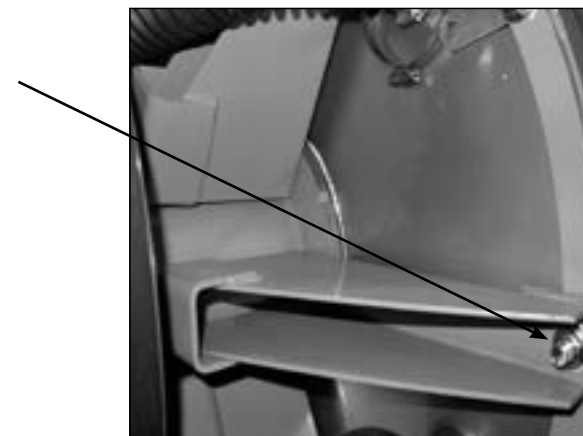

Basket Pulley, Bearing Housing, Water Seals and Tub Back

The cast iron basket pulley is retained by a bolt, locking washer and a flat washer.



Removal

- Step 1:** Insert a large screw driver or punch through a spoke in the pulley into the bearing housing support. This keeps the pulley from turning.
- Step 2:** Remove the retaining bolt, lockwasher and flat washer and reinstall just the bolt.
- Step 3:** Use a puller to remove the pulley from the shaft. Watch for tolerance ring.

Reassembly

- Step 1:** Make sure that the tolerance ring is in place inside the pulley.
- Step 2:** The shoulder inside the pulley that holds the tolerance ring should face the back of the washer when installed correctly.
- Step 3:** Use a stack of flat washers and a longer bolt to press the pulley onto the basket shaft.
- Step 4:** Reinstall the retaining bolt, lock washer and flat washer. The shaft end bolt with washer should be installed with a torque value listed in charts in this manual.

Removal of Bearing Housing From Basket Shaft, Bearings and Water Seals



- Step 1:** To remove the tub back assembly, the 6 bolts attaching it to the bearing housing must be removed.
- Step 2:** Remove water seals from the seal mounting plate on the cylinder shaft. These are removed with your fingers.
- Step 3:** The retaining ring next to the front bearing must also be removed.
- Step 4:** The bearings are pressed into the housing and must be pressed back out.

Reinstallation onto Basket Shaft

- Step 1:** Carefully set the assembly over the shaft engaging the bearings and bearing spacer.
- Step 2:** The tolerance ring that fits inside the pulley should be placed in position (see Basket Pulley Reassembly for correct positioning).
- Step 3:** The pulley should then be started onto the shaft. A stack of flat washers and a longer pulley bolt will be required to pull the basket shaft through the bearings and pulley.
- Step 4:** Install the shaft end bolt with washers and torque to specifications in Bolt Torque Chart.
- Step 5:** See Tub Back, Bearing and Cylinder Assembly for installation of complete assembly back into washer.

Reassembly

- Step 1:** When installing new bearings into a bearing housing, first press the front (large) bearing into the housing until it bottoms. With the bearing spacer in place, press the rear bearing in until the spacer is snug between the two bearings. Be sure and reinstall the retaining ring in front of the front bearing (see picture).
- Step 2:** The tub back assembly should be reattached to the bearing housing with the 6 mounting bolts and torqued according to the torque chart.
Note: The bead of silicone that seals each bolt to the tub back. This must be cleaned and replaced upon reassembly (see picture).
If the 6 support assemblies have been removed from the bearing housing, the 6 rear bearing housing bolts should be torqued according to the chart also.
- Step 3:** The primary and secondary seals that mount on the sealing ring may be slid over the shaft and seated on the metal sealing ring. In the unlikely event that the metal ring that mounts these sealing rings were to be damaged or moved, a new one would need to be pressed on. The ring must be pushed against the stop on the shaft. Before installing the new sealing ring, a bead of silicone should be put on the basket shaft (see picture). After installing the seals, lubricate the faces of the seals with silicone grease (see picture).



Drive Motor Removal

- Step 1:** Remove the drive belt as explained in previous instructions.
Note: The T-400 and T-600 have two drive belts that should be replaced in pairs.
- Step 2:** Remove the tension spring and bracket.
- Step 3:** Disconnect the motor wires at the variable frequency drive unit. The motor wire retaining clamp should be removed and reused. It is good to notate the location of the T1, T2, and T3. (It is normal in most cases that the T1 and T2 wires are swapped at the variable frequency drive.)
- Step 4:** Loosen the set screws on the motor support shaft.
- Step 5:** Remove the retaining bolt from the front of the support shaft.
- Step 6:** Remove the motor support shaft.
- Step 7:** Lift motor out of machine. Note: On larger washers it is advisable to put a board under the motor and slide it out rather than lifting it.

Section 5:

Trouble Shooting

Common Troubleshooting Solutions

Symptom	Probable Cause	Suggested Remedy
Machine does not start	Power Supply	Check these areas: Circuit breakers, Voltage, Power leads, Power connections. Is front display LED showing a dollar amount.
	Door Switch	Check for continuity through door switch when door is closed. If no continuity, adjust or replace door switch.
	Control Breaker	Check 1.5 amp (T-950 and T-1200 use 2.5amp) breaker or fuse for continuity. If no continuity, replace breaker or fuse.
	Control Transformer (3 Phase Only)	Check voltage output from control transformer for 120VAC. If voltage is incorrect, replace transformer.
	Start Switch	When actuated there must be continuity through the contacts on the start switch.
	Pause-Run Switch	Must be in Run position and should have continuity through the switch.
	Off-On Switch	Check the continuity in "On" Position. If no continuity, adjust or replace switch.
	Timer	Check to insure the timer is in the "off" position to supply 120VAC through the Start cam to the coin accumulator board.
	Timer, Rapid Advance Motor	Check the rapid advance motor for continuity and replace if no continuity.
Door does not lock	Timer Position	The following sequence must have taken place to advance the timer before the door locks: 1. Loading door closed 2. Proper number of coins inserted to start machine 3. Accumulator counted and credited coins to advance timer into cycle closing on-off timer contact.
	Door locking Solenoid	Check to insure that Solenoid is receiving 120VAC from main S1 door switch. If it is, replace solenoid.
	Door Switch	Check for continuity through door latch switch when door closed. If no continuity, adjust or replace door switch.

Common Troubleshooting Solutions

Symptom	Probable Cause	Suggested Remedy
Door will not open	Thermoactuator	Check to see if thermoactuator(s) and/or its mechanism is stuck or binding and not allowing the door lock gear motor to open. Check to be sure that the locking thermoactuator is not receiving 120VAC during the last 1 1/2 minutes of the cycle. Also check to see that the unlocking thermoactuator is receiving 120VAC during the last minute of the cycle. If the thermoactuators do not receive voltage at the correct times, change the timer. If the timing and voltage are correct, replace the thermoactuator.
	Door Rod	Check to see that door rod from solenoid to lock ass y is long enough to allow lock ass y to disengage. If not, adjust rod.
	Door Locking Solenoid	Check that door lock solenoid is not stuck closed. If stuck, replace solenoid.
	Timer	Make sure machine is in off position allowing Timer to authorize door unlock.
Machine starts but timer will not advance	Main Timer Drive Motor	If 120VAC is supplied to timer motor, but it doesn't operate, replace timer motor.
	Water Valves	Check to ensure that water valves are operating. If not, check for 120VAC to water valve from timer. If 120VAC, clean screens. If still no operation, change water valve. If no voltage, check pressure switch then change timer.
	Drain Valve	Check to ensure that drain valve is closing. If not, check for 120VAC to drain valve from timer. If 120VAC, change or clean drain valve. If no voltage, change timer.
	Fill Hose Screens & Water Valve Screens	Check all screens for obstructions and clean.
	Water	Check to ensure that water is turned on and operating.
	Pressure Switch Hose	Check hose for holes. Be sure the inlet end of the large part of the hose is lower than the rest of the hose and is free of debris.
	Pressure Switch	Check to ensure that pressure switch has continuity between #21 and #22 and #11 and #12. If no continuity, check pressure switch hose for obstruction. If hose is clear, change pressure switch.
	No hot water in detergent dispenser	Water Valve Coil
Water Inlet Screens		Check water inlet screens for blockage and clean screens if necessary.
Water		Check to insure that water is turned on and operating.
Timer		Advance to wash, check for voltage on red/org in from timer. If not voltage, replace timer.
	Pause-Run Switch	Check in "Run" position for continuity. If no continuity, replace switch.

Common Troubleshooting Solutions

Hot water does not enter tub in wash	Water Valve Coil	Check coil continuity at terminals and replace if no continuity. Check for 120 V power from main relay PCB
	Water Inlet Screens	Check water inlet screens for blockage and clean if necessary screens
	Water	Check to insure that water is turned on and operating.
	Timer	Advance machine into wash cycle and check for 120VAC at red/blue wire coming from timer.
	Water Temp Selector Switch	Check switch for continuity between red/blue wire and red/yellow wire when Hot is selected. If no continuity, change switch.
	Pressure Switch	Check pressure switch continuity between terminals . If no continuity, check pressure switch hose for obstruction. If hose okay, change pressure switch.
	Pause-Run Switch	Check in "Run" position for continuity. If no continuity, replace switch.
No cold water to tub in wash	High Water Level Relay	Check for continuity across NC contacts of high water level relay. If no continuity, replace relay.
	Water Valve Coil	Check coil continuity at terminals and replace if no continuity.
	Water Inlet Screens	Check water inlet screens for blockage and clean if necessary.
	Water	Check to insure that water is turned on and operating.
	Timer	Choose cold cycle, advance to wash, check for voltage on white/black from timer. If no voltage, replace.
	Water Temp Selector Switch	Choose cold cycle, advance to wash and check wht/org wire from selector switch for 120VAC. If no voltage, change switch.
	Pressure Switch	Check pressure switch continuity between terminal contacts. If no continuity, check pressure switch hose for obstruction. If hose okay, change pressure switch.
	Pause-Run Switch	Check in "Run" position for continuity. If no continuity, replace switch.
	High Water Level Relay	Check for continuity across NC contacts of high water level relay. If no continuity, replace relay.
Water comes in but level does not rise	Hot Rinse Relay	Check for continuity across NC contacts of hot rinse relay. If no continuity, replace relay.
	Drain Valve (open)	Check these areas • Drain valve blockage • Drain valve motor and gear train. If power but drain valve does not close, replace valve. • Power to the drain valve. If no power to drain valve, check (brn/yel) circuit for power.
Water level too high	Pressure Switch	Check for blockage in pressure switch hose. Check for pressure switch opening circuit across terminals . Replace switch if contacts do not open.
	High Water Level Relay	Check for continuity across NC contacts of high water level relay. If not contunity, replace relay.

Wiring Harness Part # by Model

Key	Description	WCN25AA	WCN25AB	WCN40AA	WCN40AB	QTY
Use Following Items with Timer Part Number 9571-359-002						
*	Wiring Harness, Main	9627-680-002	9627-680-002	9627-680-002	9627-680-002	1
*	Wiring Harness, Control	9627-681-003	9627-681-003	9627-681-003	9627-681-003	1
Use Following Items with Timer Part Number 9571-361-002						
*	Wiring Harness, Drain Valve	9627-683-001	9627-683-001	9627-683-001	9627-683-001	1
*	Wiring Harness, Control	9627-694-001	9627-694-001	9627-694-001	9627-694-001	1
*	Wiring Harness, Main	9627-702-003	9627-702-003	9627-702-003	9627-702-003	1
*	Wiring Harness, Injector Control	9627-691-001	9627-691-001	9627-691-001	9627-691-001	1
*	Clamp, Cable- 1/4 Dia	8654-125-001	8654-125-001	8654-125-001	8654-125-001	1

Section 6:

Parts Data

N-Series Vended

Regular Chassis

- Models**
WCN25AADX
WCN25ABDX
WCN40AADX
WCN40ABDX

Cabinet and Front Panel Group Part # by Model WCN25AADX/WCN25ABDX

Key	Part Number	Description	MODELS	
			WCN25 A	WCN25 B
1	9454-656-001	Panel, Side (Left or Right) - Stainless.....	2	2
1	9454-656-003	Panel, Side (Left or Right) - Gray.....	2	2
*	9545-018-013	Screw, (Side Panel to Base}.....	6	6
*	8640-414-006	Nut, Hex.....	6	6
*	9029-066-001	Bracket, Side Panel.....	1	1
*	8640-413-002	Nut, Hex.....	2	2
*	9545-008-026	Screw.....	2	2
2	9454-659-001	Panel Assy, Front.....	1	1
*	9059-063-002	Sand, Edge Protector	1	1
*	9545-008-026	Screw, Hex- To Control Panel.....	2	2
*	8640-399-008	Nut, Spring- To Control Panel.....	2	2
3	8502-624-002	Label, Door Opening.....	1	1
4	9545-008-014	Screw, Flat Head- Front to Sides.....	2	2
4	8641-585-001	Washer, Finish.....	2	2
*	8640-399-008	Nut, Spring- To Front Panel.....	2	2
*	9545-008-023	Screw, Guide.....	2	2
12	9989-458-001	Panel, Control (Mounts Nameplate).....	1	1
*	9545-008-006	Screw, Control Panel to Sides.....	4	4
11	9412-095-002	Nameplate, Control Panel (one piece).....	1	1
9	9454-663-001	Panel, Top.....	1	1
10	8650-012-003	Lock, Top (w/Key).....	1	1
*	6292-006-007	Key, Top-6324.....	1	1
*	9095-038-001	Cam, Lock-Top.....	1	1
*	8640-426-001	Nut, 9/32.....	1	1
*	8641-581-008	Washer.....	1	1
5	9108-097-001	Door, Lower Service.....	1	1
8	9244-081-002	Handle (bumper guard).....	1	1
*	9545-008-023	Screw, Guide	4	4
6	9545-008-014	Screw Mtg., Flat Head.....	2	2
6	8641-585-001	Washer, Finish.....	2	2
7	8640-399-008	Nut, Spring.....	2	2
15	9108-095-003	Door, Dispenser.....	1	1
*	9451-191-001	Pin, Plain.....	2	2
16	9467-025-001	Post, Door Mounting.....	2	2
*	9545-045-002	Screw, Dispenser Post Mtg.....	4	4
*	9545-008-012	Screw, Dispenser Mounting.....	4	4
*	8640-399-007	Nuts, Spring.....	4	4
*	9086-017-001	Catch, Top Panel.....	1	1
*	9467-024-001	Post, Top Locator.....	2	2
*	8640-411-003	Nut, Keps.....	2	2
*	9355-001-001	Locator, Panel.....	2	2
*	9545-008-025	Screw, #10.....	2	2
*	Not Illustrated			

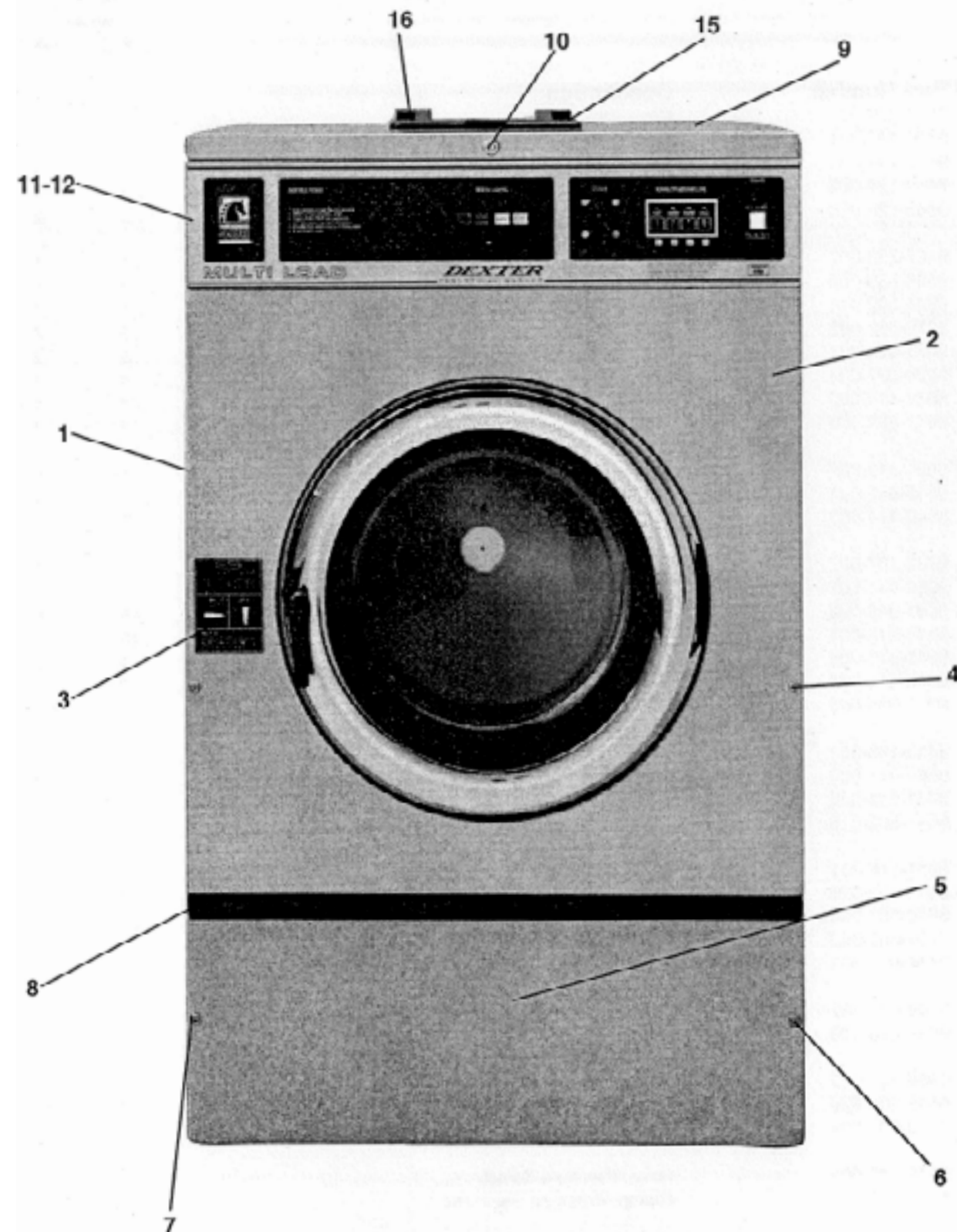

Cabinet and Front Panel Group Part # by Model WCN40AADX/WCN40ABDX

Key	Part Number	Description	MODELS	
			WCN40	
			A	A
			A	B
1	9989-449-001	Panel, Side (Left or Right)- Stainless	2	2
*	9545-018-013	Screw, (Side Panel to Base)	8	8
*	8640-414-006	Nut	8	8
*	9029-066-001	Bracket, Side Panel	1	1
*	8640-413-002	Nut, Hex #10	2	2
*	9545-008-026	Screw, #10	2	2
2	9454-669-003	Panel Assy, Front	1	1
*	9059-063-002	Band, Edge Protector (mounted to front panel)	1	1
*	8640-399-005	Nut, Spring- To Control Panel	2	2
*	9545-008-006	Screw, Hex- To Control Panel	2	2
3	9545-008-014	Screw, Flat Head	2	2
3	8641-585-001	Washer, Finish	2	2
3	8640-399-008	Nut, Spring	2	2
3	9545-008-023	Screw, Fillister Head Guide	2	2
4	8502-624-002	Label, Door Opening	1	1
8	9989-459-001	Panel, Control (Mounts Nameplate)	1	1
*	9545-008-026	Screw, Control Panel Mtg	4	4
7	9412-096-002	Nameplate, Control Panel.....	1	1
9	9454-664-001	Panel, Top	1	1
10	8650-012-003	Lock, Top (w/Key)	1	1
*	6296-006-007	Key, Top-6324	1	1
*	9095-038-001	Cam, Lock Top	1	1
*	8640-426-001	Nut, 9/32	1	1
*	8641-581-008	Washer	1	1
5	9108-097-001	Door, Lower Service	1	1
11	9244-081-002	Handle (bumper guard)	1	1
*	9545-045-010	Screw (mounting handle)	4	4
6	9545-008-014	Screw, Flat Head	2	2
6	8641-585-001	Washer, Finish	2	2
6	8640-399-008	Nut, Spring	2	2
*	9545-008-023	Screw, Fillister Head Guide Locating Front Panel	2	2
12	9108-095-003	Door, Dispenser	1	1
*	9451-191-001	Pin, Plain SS	2	2
*	9467-025-001	Post, Door Mounting	2	2
*	9545-045-002	Screw, Dispenser Post Mtg	4	4
*	9545-008-012	Screws, Dispenser Mounting	4	4
*	8640-399-007	Nuts, Spring	4	4
*	9086-017-001	Catch, Top Panel	1	1
*	9467-024-001	Top Panel Locator Posts	2	2
*	8640-411-003	Nut, Keps (for top panel locator posts)	2	2
*	9355-001-001	Locator, Panel	2	2
*	9545-008-025	Screw, #10	2	2

* Not Illustrated

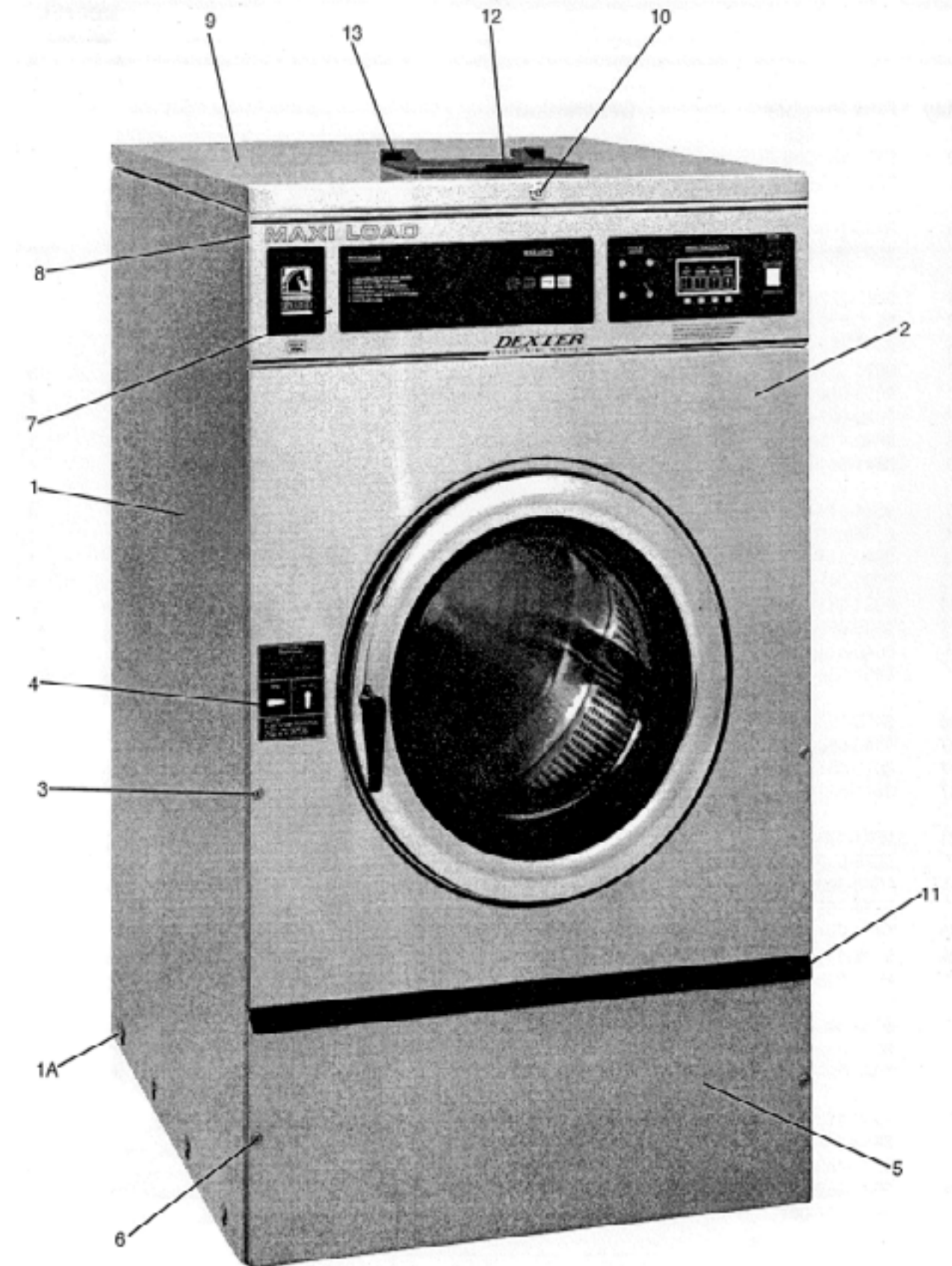

Rear View Access Part # by Model

Key	Part Number	Description	MODELS WCN25	
			A	A
2	9732-127-001	Drive Motor, 1 Phase	1	
2	9732-127-002	Drive Motor, 3 Phase		1
4	9497-222-002	Rod, Motor Mtg	1	1
5	9545-029-005	Screw {end of motor rod}	1	1
5	8641-582-014	Lockwasher (end of motor rod)	1	1
6	9076-052-002	Collar, Shaft (w/set screws)	3	3
*	9053-074-001	Bushing, Motor Hangar (for Magnatek Motors).....	2	2
7	9029-027-003	Strap, Motor Tension.....	1	1
8	8640-413-002	Nut, Strap to Motor.....	1	1
8	8641-581-006	Washer.....	1	1
9	9534-319-002	Spring, Belt Tension.....	1	1
10	9545-055-001	Bolt, Eye.....	1	1
11	8640-414-003	Nut, 1/4 Elastic Stop.....	1	1
12	9732-137-002	Back Assy, Tub.....	1	1
13	9950-041-002	Ring Assy, Tub Mtg - Rear.....	1	1
14	9991-048-002	Support Assy, Bearing Housing.....	6	6
15	9545-029-003	Screw, 1 1/2	10	10
16	9545-029-006	Screw, 1 3/4.....	2	2
*	8640-415-004	Nut, Flange Lock.....	12	12
*	9552-038-003	Shim.....	AR	AR
3	9453-170-002	Pulley, Motor	1	1
*	9545-028-015	Set Screw, Sq, Hd.....	2	2
17	9453-168-004	Pulley, Driven	1	1
18	9545-017-009	Screw	1	1
18	8641-581-026	Washer, Flat	1	1
18	8641-582-016	Lockwasher	1	1
1	9040-076-005	Drive Belt	2	2
19	9081-115-001	Channel, Rear	1	1
*	9545-008-026	Screw	4	4
*	8640-399-004	Nut, Spring	4	4
*	9454-655-002	Panel, Back Guard.....	1	1
20	9454-663-001	Panel, Top.....	1	1
21	9242-449-002	Hose, Overflow	1	1
*	8654-029-000	Clamp, Hose	2	2
*	9989-446-002	Panel Assy., Back	1	1
*	9545-008-026	Screw	10	10
*	8640-399-004	Nut, Spring	10	10
22	9242-175-000	Hose, Pressure Switch	1	1
*	8654-117-015	Clamp, Pressure Sw. Hose	1	1
23	5198-211-004	Circuit Breaker, 1.5 amp.....	1	1
24	9242-463-002	Overflow hose - 11.....	1	1
*	Not Illustrated			

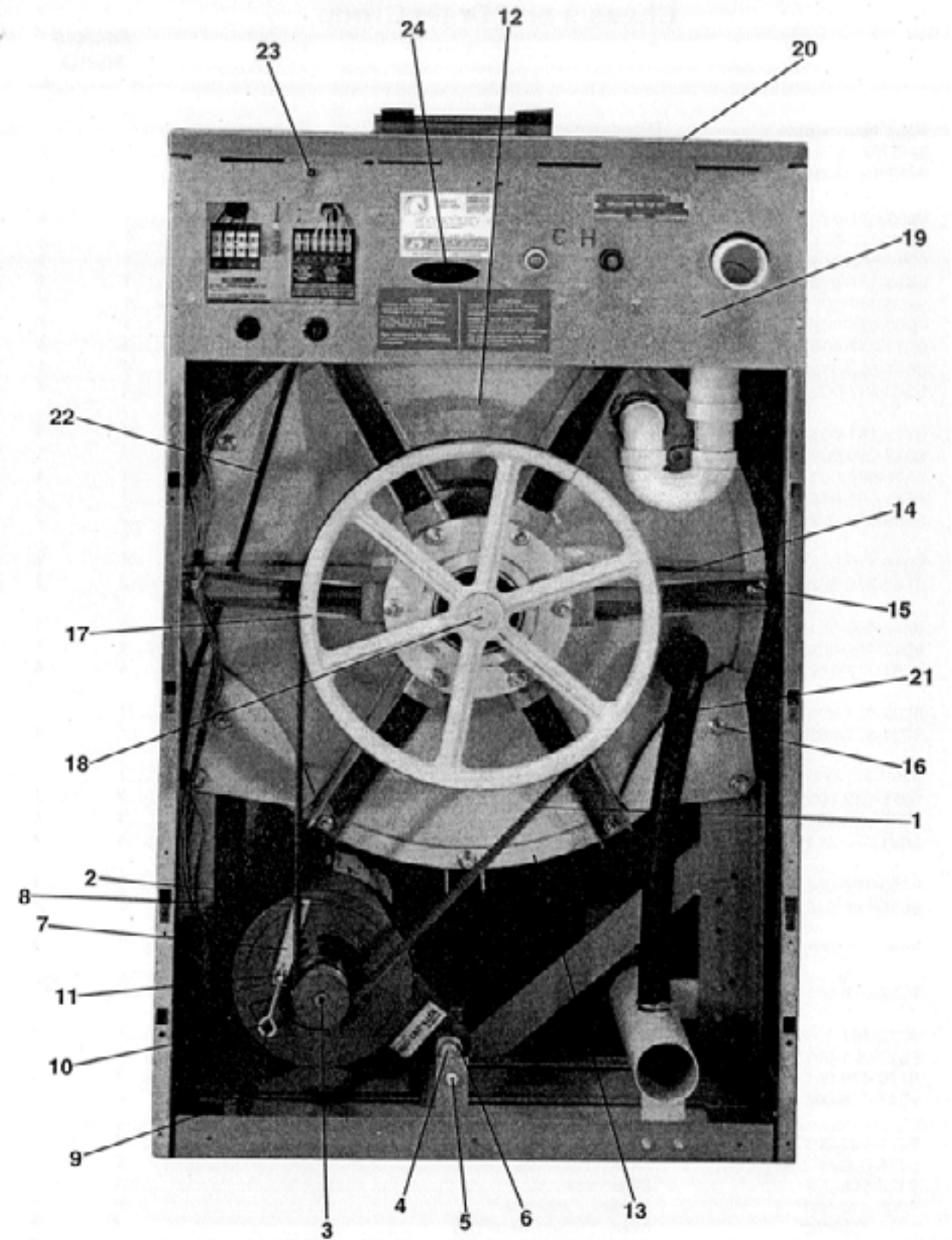

Rear View Access Part # by Model

Key	Part Number	Description	MODELS WCN40	
			A	B
1	9040-076-005	Drive Belt	2	2
2	9732-127-005	Drive Motor, 1 Phase.....	1	
2	9732-127-006	Drive Motor, 3 Phase		1
3	9453-170-002	Pulley, Motor	1	1
*	9545-028-015	Screw, set.....	2	2
4	9497-222-004	Rod, Motor Mtg.....	1	1
5	9545-029-005	Screw	1	1
5	8641-582-014	lockwasher.....	1	1
6	9076-052-002	Collar, Shaft {w/set screws)	3	3
*	9053-074-001	Nylon Bushing (For Magna-Tek Brand Motors).....	2	2
7	9029-027-003	Strap, Motor tension.....	1	1
8	8640-413-002	Nut, Strap to Motor	1	1
8	8641-581-006	Washer	1	1
9	9534-319-002	Spring, Belt Tension	1	1
10	9545-055-001	Bolt, Eye	1	1
11	8640-414-003	Nut, 114 20 Elastic Stop	1	1
13	9950-041-004	Ring Assy., Tub Mtg.- Rear.....	1	1
14	9991-051-002	Support Assy., Bearing Hsg	6	6
15	9545-059-002	Screw, 2"- Tub Back to Tub	12	12
*	8640-416-005	Nut, Flange Lock	12	12
*	9552-038-003	Shim.....	AR	AR
16	9453-168-003	Pulley, Driven	1	1
17	9545-060-001	Screw, Pulley to Shaft	1	1
17	8641-581-032	Washer, Flat	2	2
17	8641-582-018	lockwasher	1	1
21	9081-116-001	Channel, Rear	1	1
*	9545-008-026	Screw	4	4
*	8640-399-004	Nut, Spring	4	4
*	9454-655-001	Panel, Back Guard	1	1
19	9454-664-001	Panel, Top.....	1	1
20	9242-449-002	Hose, Overflow	1	1
*	8654-029-000	Clamp, Hose.....	2	2
*	9989-446-001	Panel Assy., Back	1	1
*	9545-008-026	Screw	10	10
*	8640-399-004	Nut, Spring	10	10
22	9242-175-002	Hose, Pressure Switch	1	1
*	8654-117-015	Clamp, Pressure Sw. Hose	1	1
23	9242-463-003	Overflow Vent Hose 12 1/4	1	1
24	9883-007-001	Injector Asseby PVC	1	1
*	0935-127-001	End Cap (For Chemical Injection Hose Insertion).....	1	1

* Not Illustrated

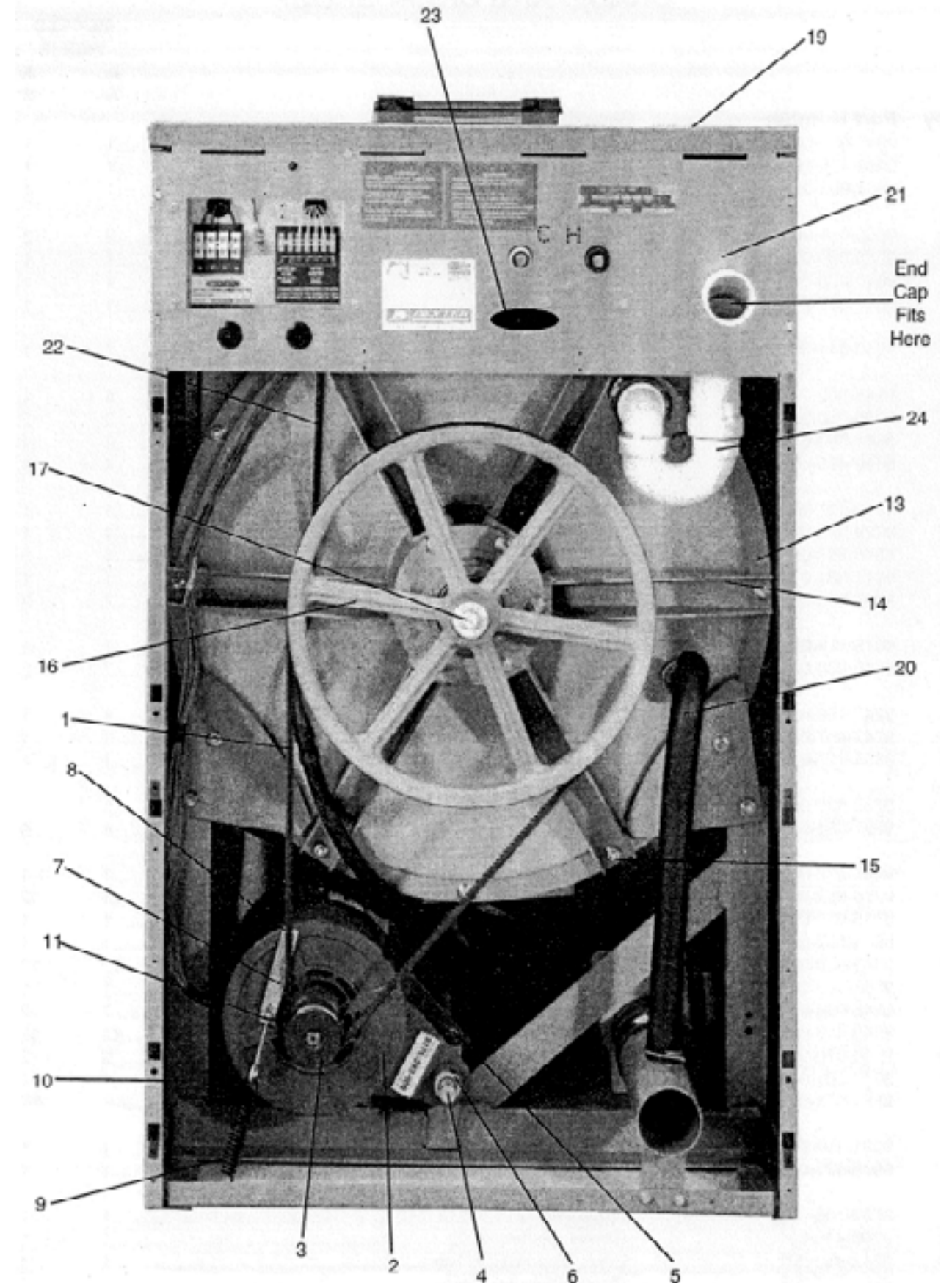

Cylinder, Seals & Bearings Part # by Model

Key	Part Number	Description	MODELS WCN25	
			A	B
*	9848-109-001	Cylinder Assy	1	1
*	9803-179-002	Housing, Bearing-Assembly (includes items 2-6)	1	1
2	9241-169-002	Housing, Bearing	1	1
3	9036-159-002	Bearing, Front	1	1
4	9036-159-001	Bearing, Rear	1	1
5	9538-158-001	Spacer, Bearing	1	1
6	9487-238-001	Ring, Bearing Retainer (internal type)	1	1
7	9732-137-002	Back Assy, Tub	1	1
8	9532-140-006	Seal, Secondary	1	1
9	9532-140-009	Seal, Primary	1	1
10	9950-042-001	Ring, Seal Mtg	1	1
11	9487-261-002	Tub Back Mating Ring	1	1
11	9732-137-002	Kit, Tub Back (2-piece kit must be used before #429963)	1	1
12	9545-017-009	Bolt, 1/2" Tub End of Bearing Housing (1/2x1 1/4)	6	6
12	8640-417-002	Nut	6	6
12	8641-582-016	Lockwasher 1/2 (ext tooth)	6	6
13	9991-048-002	Support Arm Assy, Bearing Housing	6	6
14	9545-029-003	Bolt, Pulley End of Bearing Housing (3/8x1 1/2)	6	6
14	8640-415-004	Nut, Flange Locking 3/8	1	1
*	9545-029-006	Bolt 3/8x1 1/2	2	2
15	9453-168-002	Pulley, Driven (old style - one belt, before #425720)	1	1
15	9453-168-004	Pulley, Driven (new style - two belt, after #425720)	1	1
*	9487-234-001	Ring, Tolerance	1	1
16	8641-581-026	Washer 1/2	1	1
17	9545-017-009	Bolt (1/2x1 1/4)	1	1
18	8641-582-016	Lockwasher 1/2 Ext Tooth	1	1

*Not Illustrated

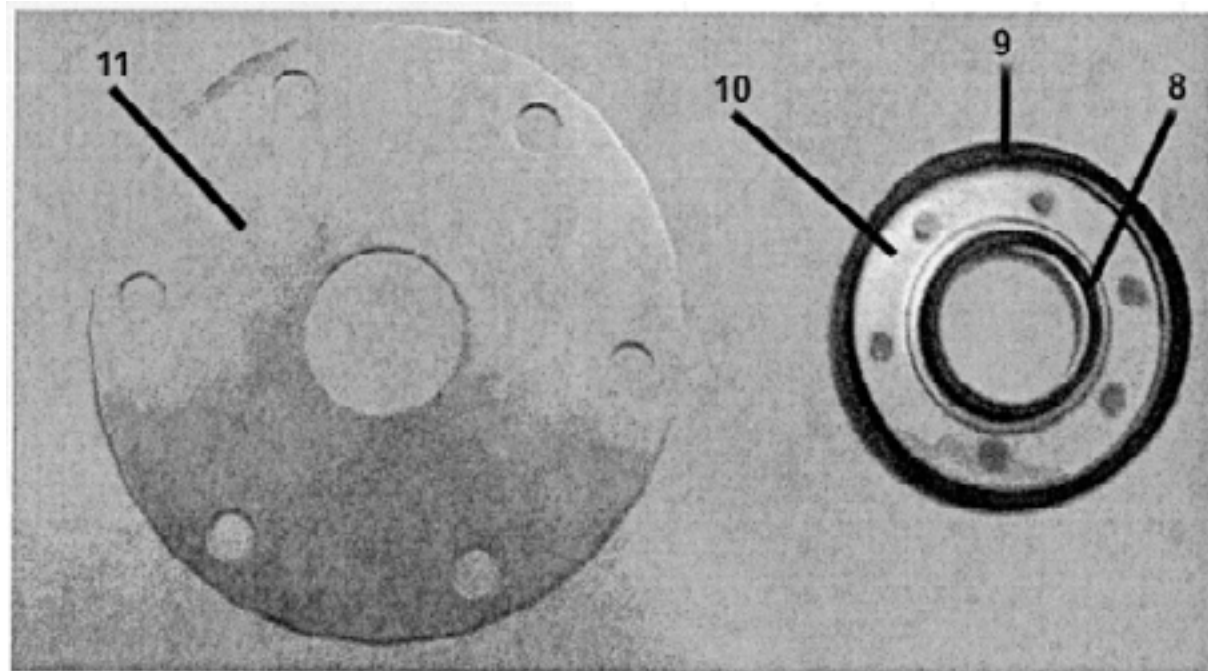

Cylinder, Waterseals, Bearing Housing and Pulley Group

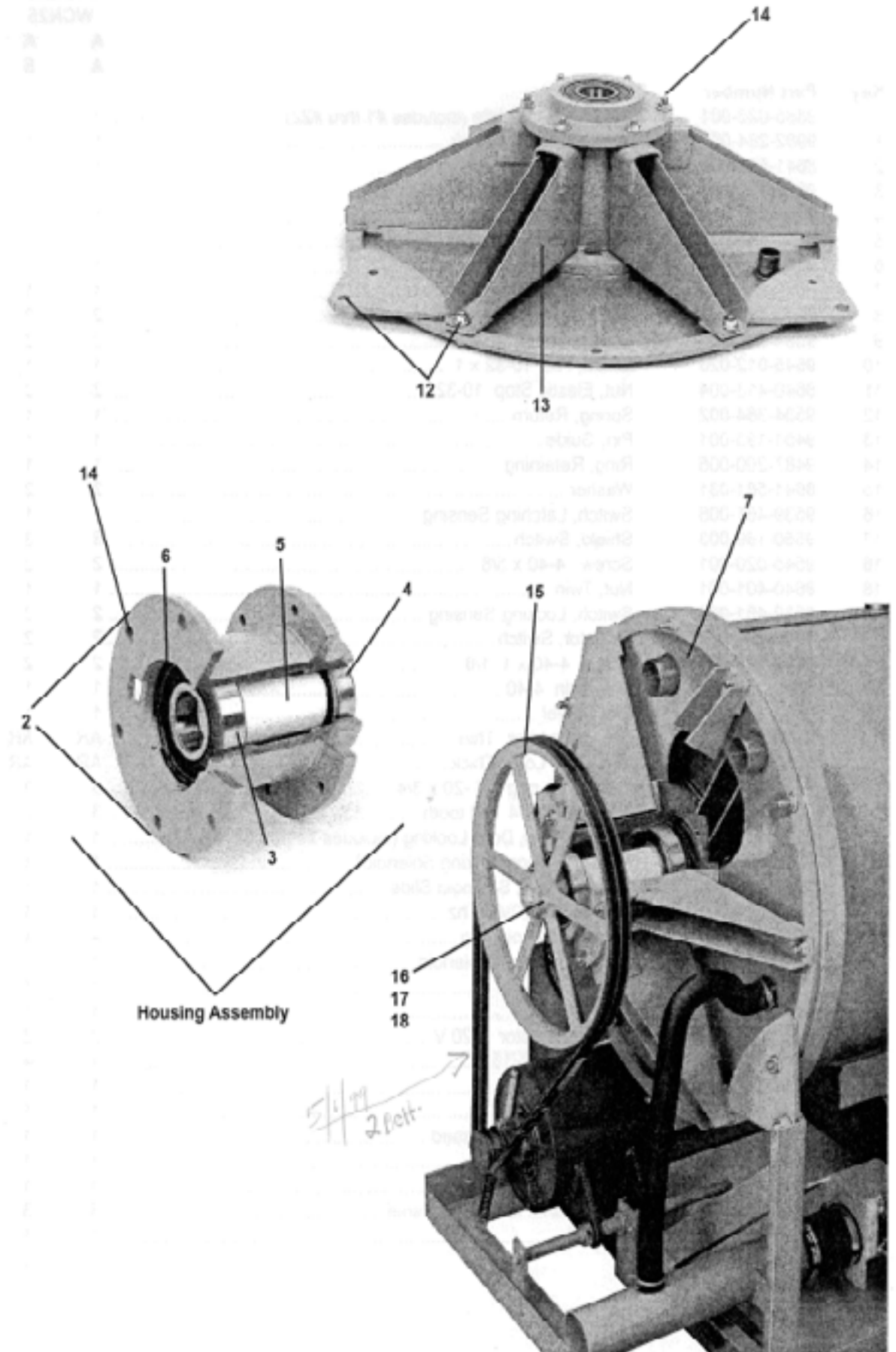

Cylinder, Seals & Bearings Part # by Model

Key	Part Number	Description	MODELS WCN40	
			A	B
1	9848-113-001	Cylinder Assy	1	1
*	9803-186-001	Housing, Bearing-Assembly (includes items 2-6)	1	1
2	9241-180-002	Housing, Bearing	1	1
3	9036-159-005	Bearing, Front	1	1
4	9036-159-004	Bearing, Rear	1	1
5	9538-167-001	Spacer, Bearing	1	1
6	9487-238-003	Ring, Bearing Retainer (internal type)	1	1
7	9732-137-004	Back Assy, Tub	1	1
8	9532-140-006	Seal, Secondary	1	1
9	9532-140-009	Seal, Primary	1	1
10	9950-042-001	Ring, Seal Mtg	1	1
11	9487-261-002	Tub Back Mating Ring	1	1
11	9732-137-003	Kit, Tub Back	1	1
12	9545-060-001	Bolt, 5/8x1 1/2 Tub End of Bearing Housing	6	6
12	8640-425-001	Nut 5/8	6	6
12	8641-582-018	Lockwasher 1/2 (ext tooth)	6	6
13	9991-051-002	Support Arm Assy, Bearing Housing	6	6
14	9545-059-003	Bolt, Pulley End of Bearing Housing (7/16x1 1/2)	6	6
14	8640-416-005	Nut, Flange Locking 7/16	6	6
15	9453-168-003	Pulley, Driven	1	1
16	9487-234-003	Ring, Tolerance	1	1
17	8641-581-032	Washer 1/2	1	1
18	9545-060-001	Bolt (5/8x1 1/2)	1	1
19	8641-582-018	Lockwasher 1/2 Ext Tooth	1	1

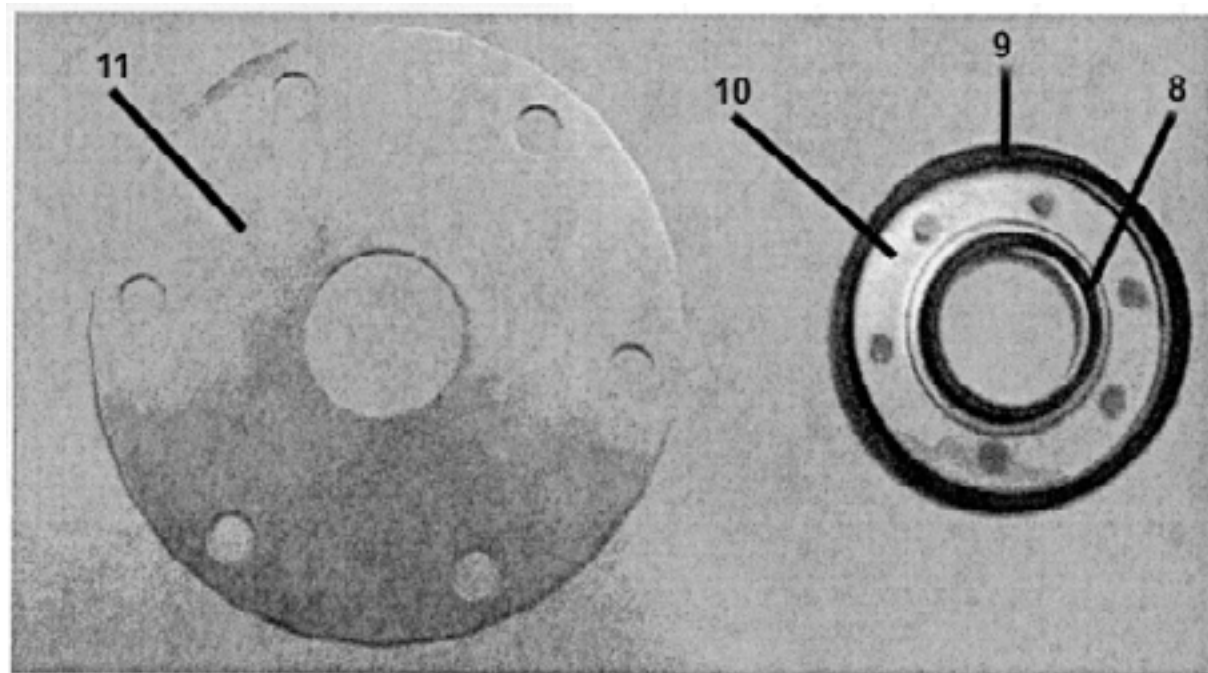

Cylinder Water Seals and Bearing Housing and Pulley Group

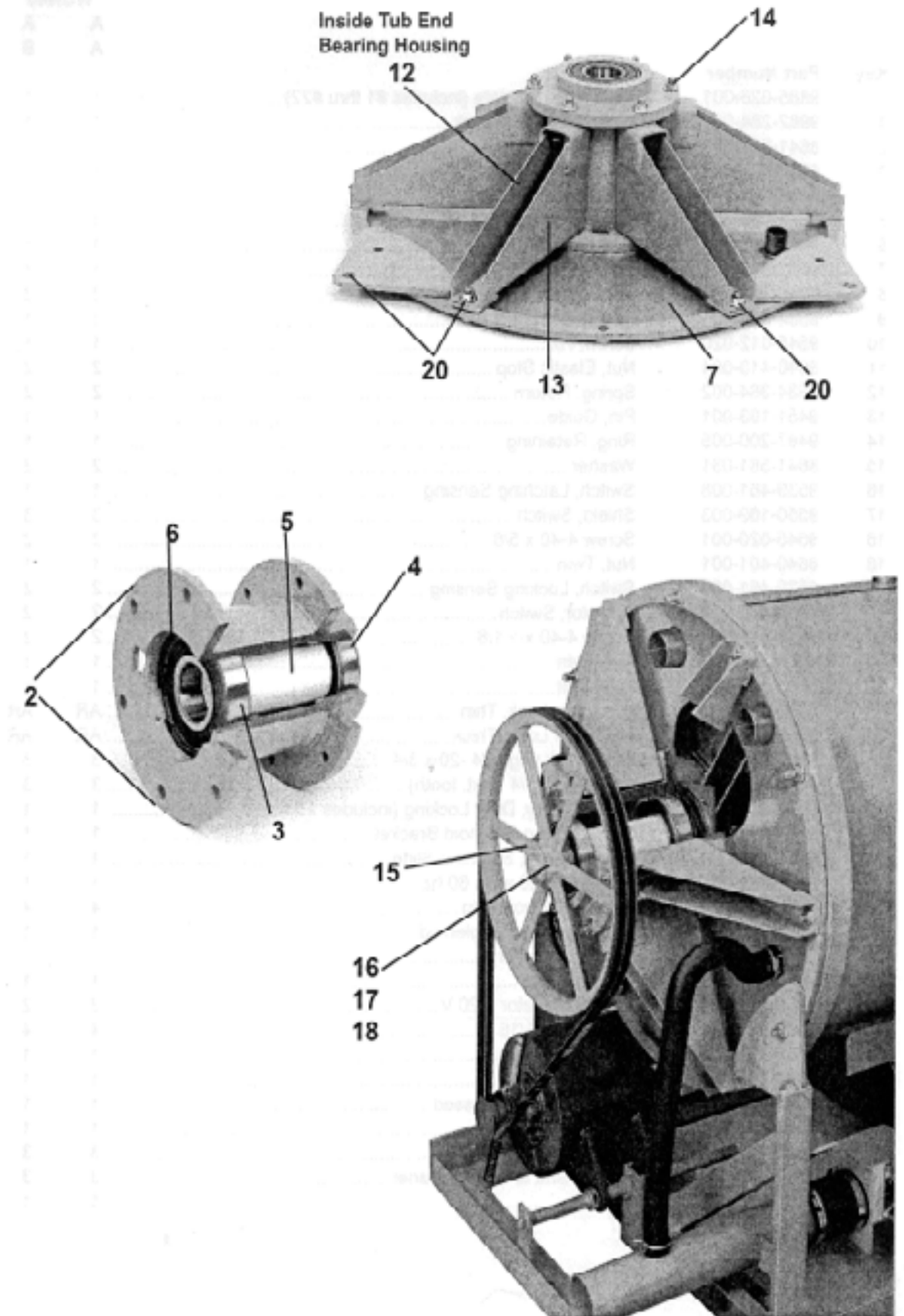

Door Latching & Solenoid Door Lock Assemblies by Part

Key	Part Number	Description	Qty
*	9885-023-001	LockAssy, Complete (includes #1 thru #22)	1
1	9982-284-001	Plate Assy, Door Lock	1
2	8641-581-030	Washer, Flat	1
3	9008-005-001	Actuator, Latching Switch	1
4	9450-002-002	Pawl, Locking	1
5	8641-569-003	Washer, Spring	1
6	9487-200-004	Ring, Ret Jning	1
7	9029-035-001	Bracket; SOWiitch	1
8	8640-413-002	Nut, Hex 10-32 UNF	2
9	9534-364-001	Spring, Actuating	2
10	9545-012-020	Screw, Hx. 10-32 x 1	1
11	8640-413-004	Nut, E.lastic Stop 10-32	2
12	9534-364-002	Spring, Return	1
13	9451-193-001	Pin, Guide	1
14	9487-200-005	Ring, Retaining	1
15	8641-581-031	Washer	2
16	9539-461-008	Switch, Latching Sensing	1
17	9550-169-003	Shield, Switch	3
18	9545-020-001	Screw 4-40 x 5/8	2
18	8640-401-001	Nut, Twin	1
19	9539-461-007	Switch, Locking Sensing	2
20	9008-006-002	Actuator, Switch	2
21	9545-020-003	Screw 4-40 x 1 1/8	2
21	8640-401-001	Nut, Twin 4-40	1
22	9451-181-004	Pin, Dowel	1
*	9552-037-001	Shim, Door Lock, Thin	AR
*	9552-037-002	Shim, Door Lock, Thick	AR
*	9545-018-014	Screw, Lock mtg 1/4 -20 x 3/4	3
*	8641-582-007	Lockwasher 1/4 Ext tooth	3
*	9922-011-001	Solenoid Ass'y, Door Locking (includes 23 thru 32)	1
23	9029-073-001	Bracket, {Door Locking Solenoid)	1
24	9985-169-001	BracketAss'y, Soienoid Slide	1
25	9536-074-001	Solenoid 120V 60 hz	1
26	9545-008-001	Screw, Solenoid Mtg	4
27	9540-033-002	Stop, Door Lock Solenoid	1
28	9545-061-001	Screw, Shoulder	1
28	8640-411-003	Nut, Keps #6	1
29	9586-001-001	Thermoactuator 120 V	2
30	9545-031-011	Screw. #6 x5/16	4
31	9538-157-004	Spacer, Plastic	1
31	9538-166-004	Spacer, Metal	1
31	9545-010-001	Screw, Cross Recessed	1
31	8640-412-005	Nut, Keps #8	1
32	8640-411-002	Nut, Keps#6	1
*	8640-412-005	Nut, Sol.Brkt. to Control. Panel	3
*	9497-225-006	Rod, Pull	1

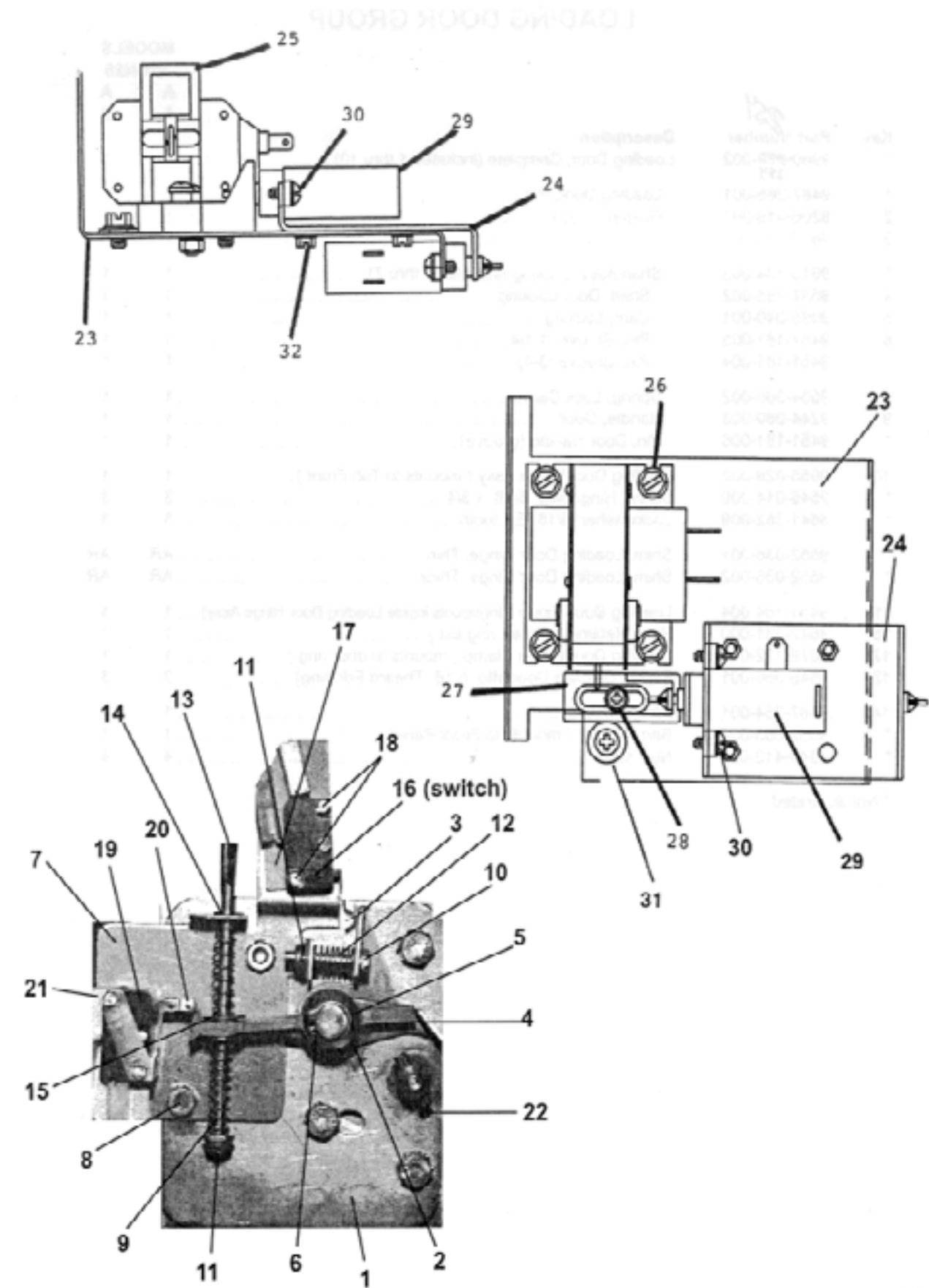

Loading Door Part # by Model

Key	Part Number	Description	Qty
*	9960-259-002	Loading Door, Complete (includes 1 thru 10)	1
1	9487-230-001	Loading Door, Ring	1
2	9206-419-001	Gasket, Loading Door	1
3	9635-016-001	Window, Loading Door	1
4	9913-134-003	Shaft Assy, Locking (includes 4 thru 7)	1
*	9537-195-002	Shaft, Door Locking	1
5	9095-040-001	Cam, Locking	1
6	9451-181-005	Pin, Groove (1 1/4)	1
7	9451-181-004	Pin, Groove (3/4)	1
8	9534-360-002	Spring, Lock Cam	1
9	9244-080-003	Handle, Door	1
*	9451-181-006	Pin, Door Handle (Groove)	1
*	9545-014-009	Screw, Hinge Mtg	3
*	8641-582-009	Lockwasher 5/16	3
*	9552-036-001	Shim, Loading Door Hinge (Thin)	AR
*	9552-036-002	Shim, Loading Door Hinge (Thick)	AR
10	9955-028-003	Hinge Assy, Loading Door (Mounts to tub front)	1
11	9451-184-003	Pin, Loading Door Hinge (Fits inside loading door hinge)	1
12	9079-122-002	Clamp, Loading Door Hinge	1
13	9545-056-001	Screw, Loading Door Mtg	3
14	9487-254-001	Ring, Masking	1
*	8640-413-002	Nut	4
*	9059-063-001	Band, Edge Protector (Mounted to front panel)	1

*Not illustrated

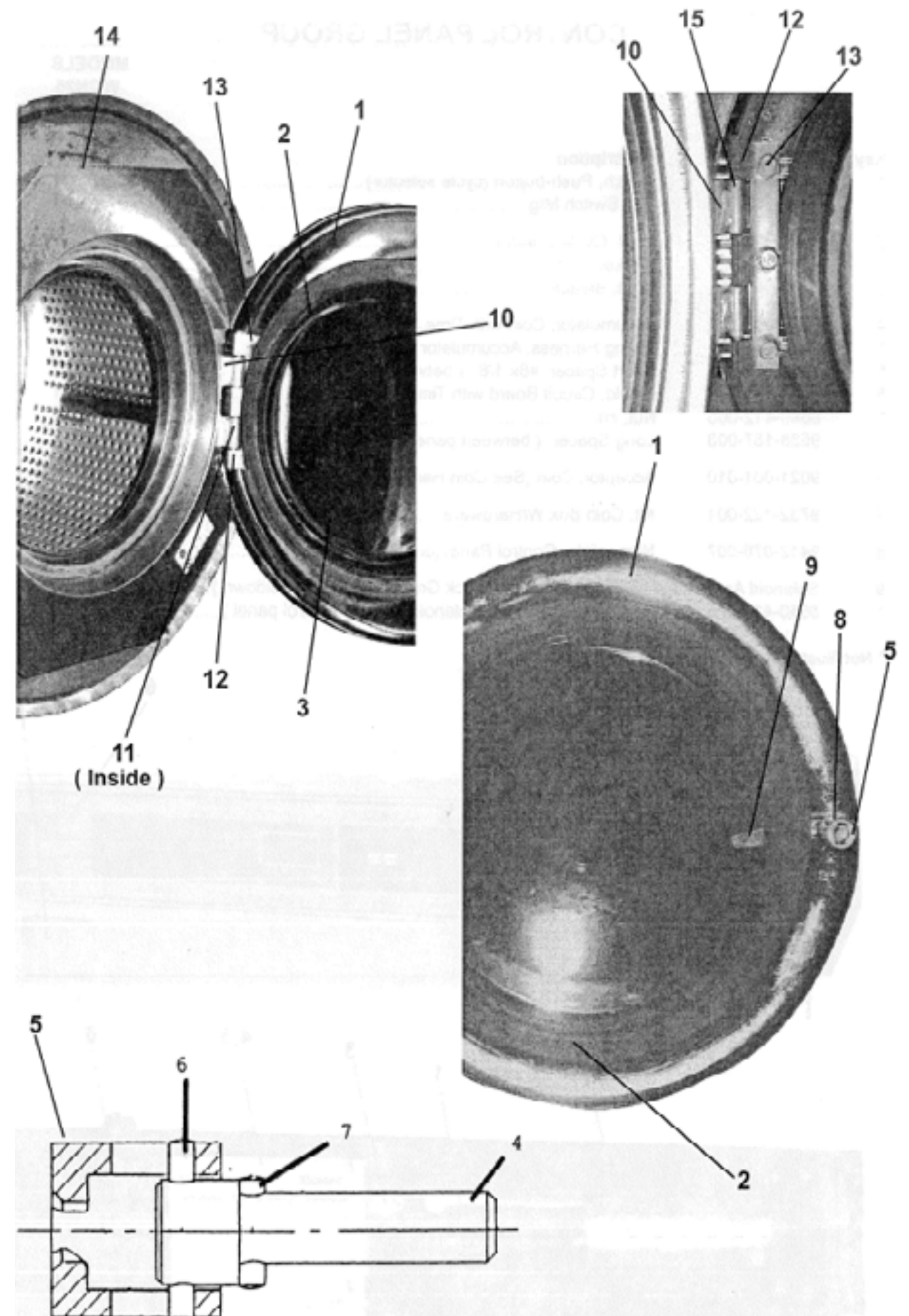

Chassis and Drain Part # by Model

Key	Part Number	Description	MODELS	
			W	CN25
1	9945-087-002	Base Assy, Frame	1	1
2	9930-137-001	Tub Assy	1	1
3	9950-051-002	Ring Assy, Tub Mtg-Front	1	1
4	9545-017-003	Bolt, Top Front Ring	1	1
4	8641-582-016	Lockwasher	1	1
4	8640-417-002	Nut.	1	1
5	9950-041-002	Ring Assy, Tub Mtg-Rear	1	1
5a	9950-054-002	Ring Ass'y--Seal Tubback	1	1
6	9545-017-009	Screw, Front & Rear Rings to Base	4	4
6	8641-582-016	Lockwasher	4	4
6	8640-417-002	Nut.	4	4
7	9379-187-001	Valve, Drain	1	1
8	9029-056-001	Bracket, Drain Valve	1	1
*	9545-048-001	Screw, Valve to Bracket	1	1
*	8641-581-018	Washer	1	1
9	9545-030-002	Screw, Bracket to Base	2	2
10	9915-119-002	Tube Assy, Drain	1	1
10a	9545-.030-002	Screw, Tube Mtg	2	2
11	9242-456-001	Hose, Tub to Drain Valve	1	1
12	9242-457-001	Hose, Drain Valve to Tube	1	1
12a	8654-117-014	Clamp, Hose	4	4
13	9732-127-001	Motor, Drive (1 PH)	1	
13	9732-127-002	Motor, Drive (3 PH)		1
14	9497-222-002	Rod, Motor Mtg	1	1
15	9076-052-002	Collar, Shaft	2	2
16	9545-029-005	Screw, Motor Mtg Rod	1	1
16	8641-582-014	Lockwasher	1	1
17	9453-168-004	Pulley, Motor	1	1
*	9545-028-015	Set Screw, Sq. Hd	2	2
18	9040-076-005	Belts, Drive	2	2
*	9552-038-003	Shim, Support Assembly	AR	AR
19	9242-461-001	Hose, Vacuum Brkr. to Tub	1	1
20	9610-001-001	Vacuum Breaker	1	1
21	9029-078-001	Bracket, Vacuum Breaker	1	1
22	9545-008-005	Screw	4	4
*	9081-104-001	Channel, Rear	1	1
*	9475-002-002	Flow Restrictors	2	2
23	9122-005-004	Dispenser	1	1
24	9206-416-001	Gasket, Dispenser	1	1
25	9242-450-002	Hose, Dispenser to Tub	1	1
26	8654-117-008	Clamp, Dispenser Hose	2	2
25	9242-463-002	Overflow Vent hose 11	1	1

*Not illustrated

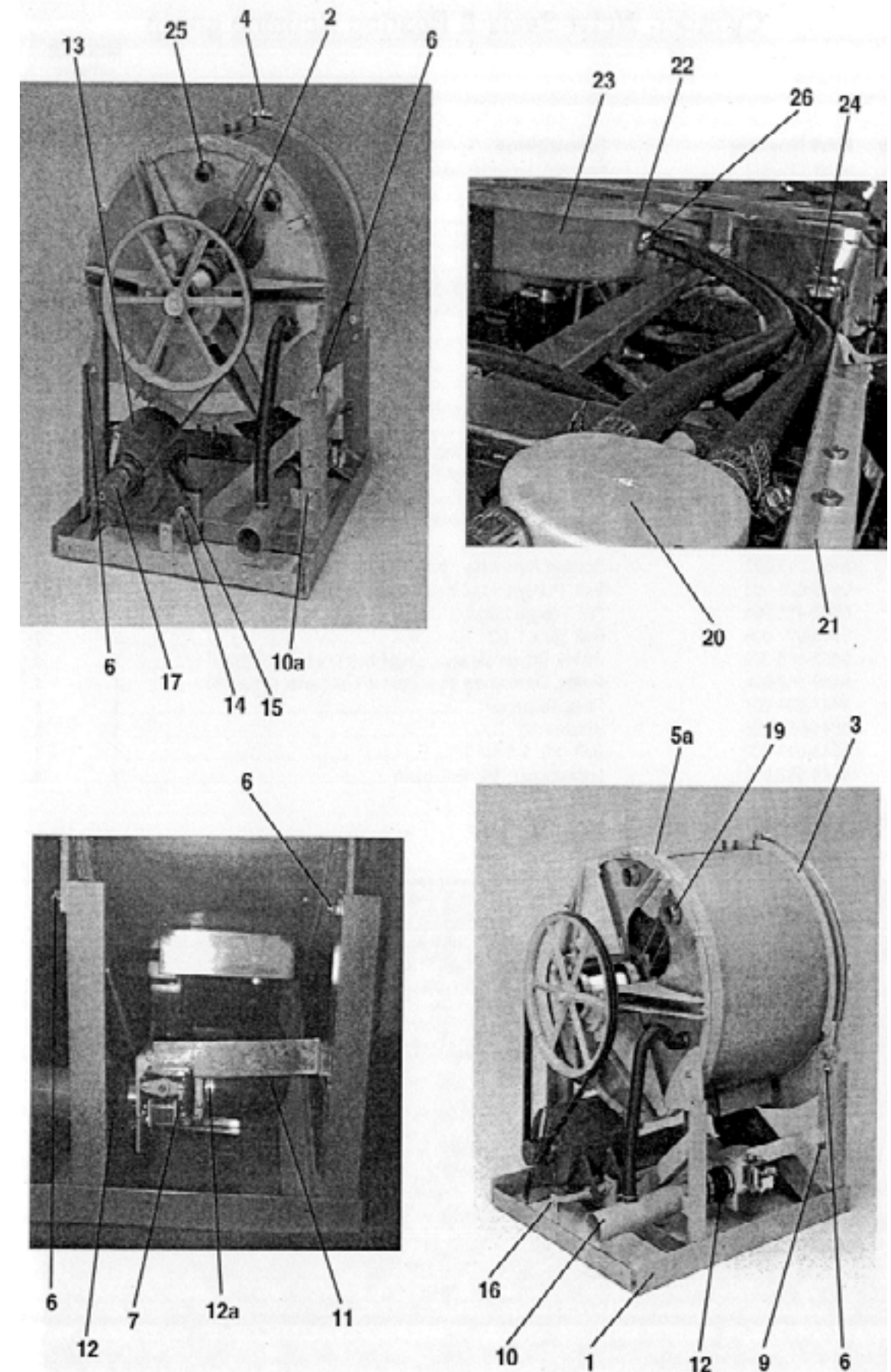

Chassis and Drain Part # by Model

Key	Part Number	Description	MODELS	
			WCN40	
			A	B
1	9945-097-002	Base Assy, Frame	1	1
2	9930-136-001	TubAssy	1	1
3	9967-009-002	Cradle Assy, Tub	1	1
4	9950-050-002	Ring Assy, Tub Mtg-Front	2	2
5	9545-060-003	Screw, 5/8-3x 1	1	1
5	8640-425-011	Nut	1	1
5	8641-582-018	Lockwasher	1	1
6	9950-041-004	Ring Assy., Tub Mtg.- Rear	1	1
7	9545-060-002	Bolt, 5/8-11x1 1/2 Rings to Base (front & rear)	4	4
8	9545-060-001	Bolt, 5/8-11x2 1/2 Rings to Base (front ring to cradle}	2	2
*	8641-582-018	Lockwasher	4	4
*	8640-425-001	Nut, Hex	4	4
9	9379-187-001	Valve, Drain	1	1
11	9029-052-001	Bracket, Drain Valve	1	1
*	9545-048-001	Screw, Valve to Bracket	1	1
*	8641-581-018	Washer	1	1
*	9545-030-002	Screw, Bracket to Base	2	2
12	9915-118-002	Tube Assy, Drain	1	1
*	9545-030-002	Screw, Tube Mtg	2	2
14	9242-456-001	Hose, Tub to Drain Valve	1	1
15	9242-457-001	Hose, Drain Valve to Tube	1	1
16	8654-117-014	Clamp, Hose	4	4
17	9732-137-003	BackAssyTub	1	1
18	9991-051-002	Support Arm Assembly	6	6
*	9497-222-004	Rod, Motor Mtg	1	1
*	9076-052-002	Collar, Shaft	2	2
*	9545-029-005	Screw, Motor Mtg Rod	1	1
*	8641-582-014	Lockwasher	1	1
19	9545-059-002	Bolt 7/16 x 2 Tub Back to Tub	12	12
*	9453-170-002	Pulley, Motor	1	1
*	9545-028-015	Set Screw, Square Head	2	2
*	8640-416-005	Nut, Flange Lock	12	12
25	9040-076-005	Belt, Drive	2	2
20	9610-001-001	Vaccum Breaker	1	1
*	9552-038-001	Shim, Support Assembly	AR	AR
*	9081-116-001	Channel, Rear	1	1
*	0935-127-001	End Cap for liquid chemical injections	1	1
21	9732-105-004	Dispenser,	1	1
22	9206-416-001	Gasket, Dispenser	1	1
24	9242-450-001	Hose, Dispenser to Tub	1	1
23	8654-117-008	Clamp, Dispenser Hose	2	2

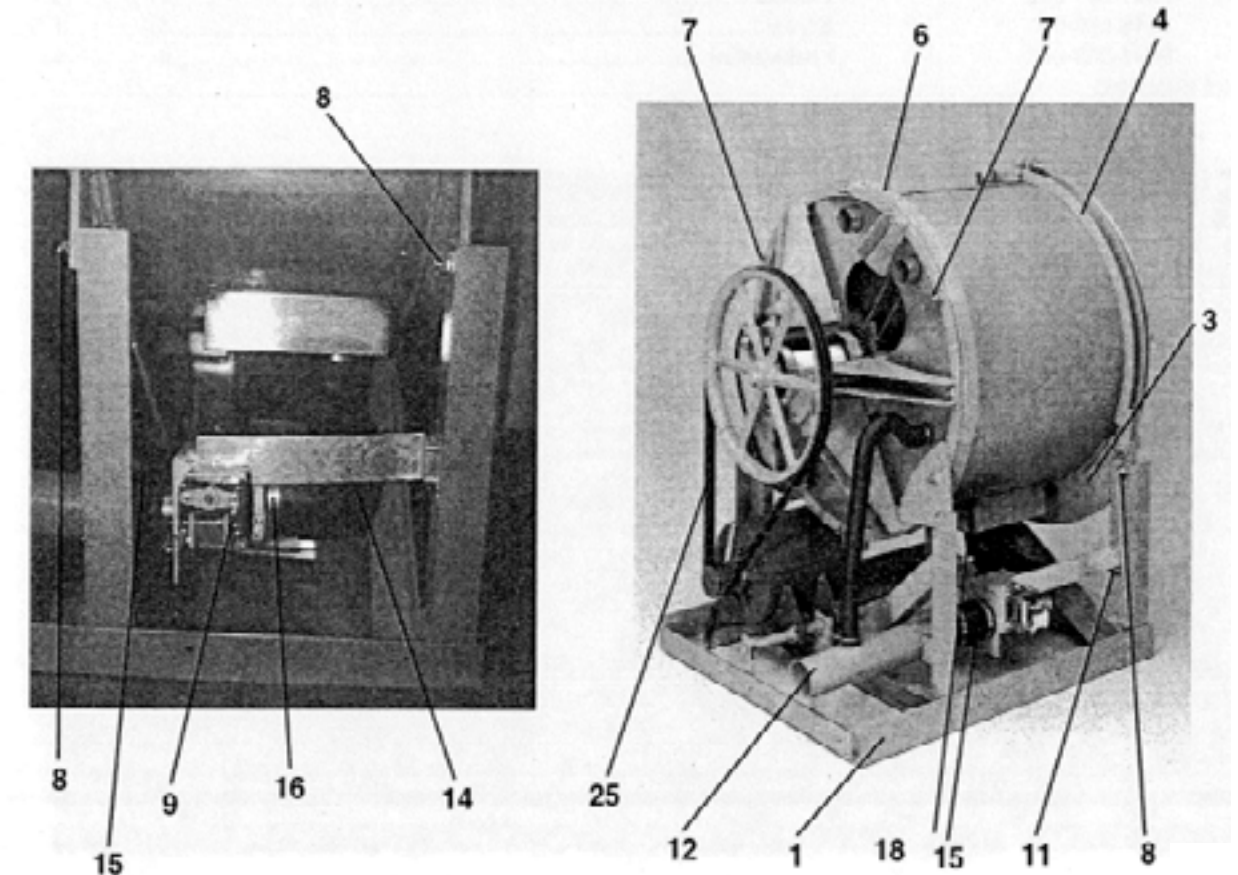
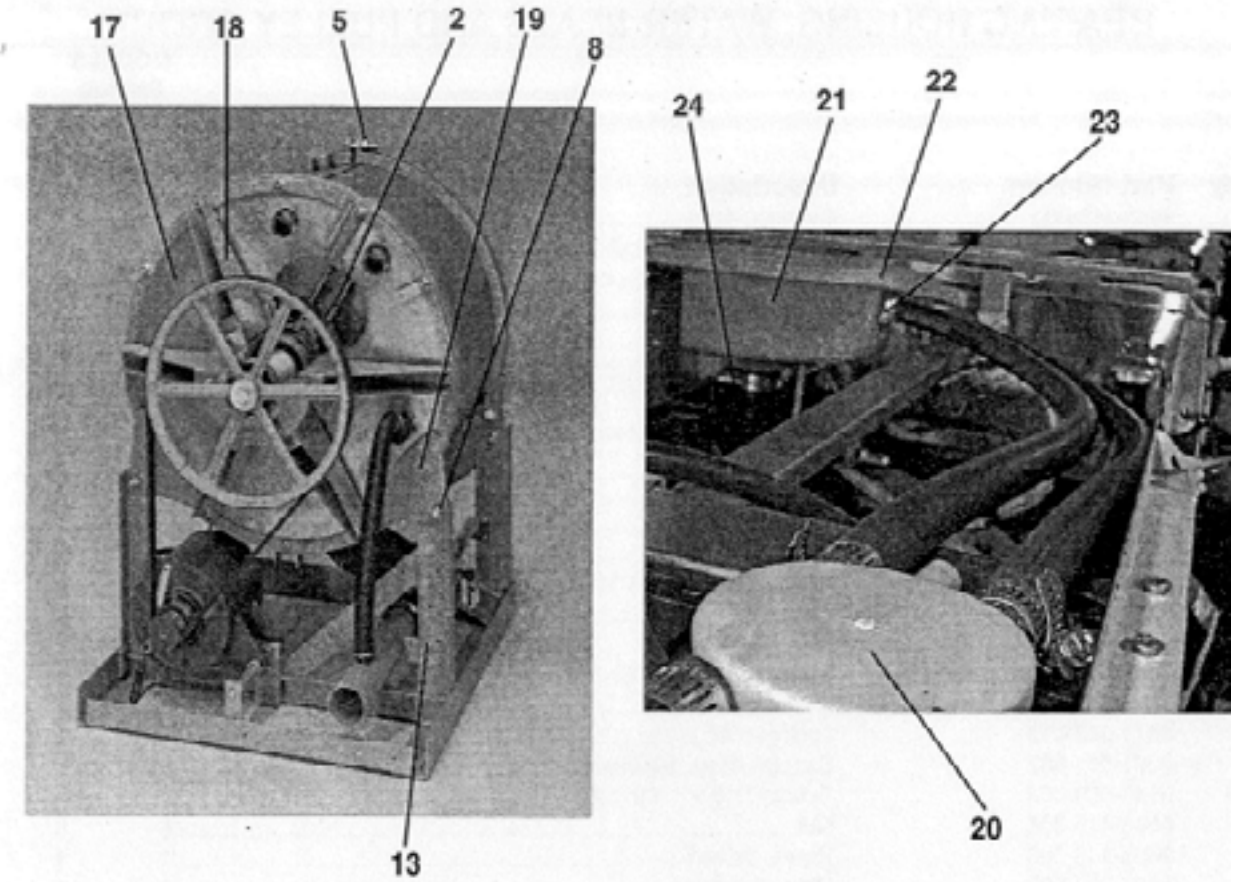

Water Inlet & Rear Channel

Key	Part Number	Description	MODELS WCN25	
			A	A
1	9379-183-012	Valve, Water Inlet (see Water Inlet Valve Breakdown for individual parts)	2	2
*	9545-008-026	Screw, Valve Mtg	4	4
*	8640-399-009	Nut, Spring	4	4
2	9610-001-001	Vacuum Breaker	1	1
*	9029-078-001	Bracket, Vacuum Breaker	1	1
3	9545-008-026	Screw	4	4
12	9242-461-001	Hose, Vacuum Breaker to Injector	1	1
*	8654-117-008	Clamp, Vacuum Breaker End	1	1
*	8654-117-008	Clamp, Tub End	1	1
4	9242-453-017	Hose, Vac. Brkr. to Wash Disp. 18 1/4	1	1
5	9242-453-016	Hose, Vac. Brkr. to Rinse Disp. 14 1/2	1	1
6	9242-453-020	Hose, Hot Valve to Vac. Brkr 18	1	1
7	9242-453-020	Hose, Hot Valve to Tub 18	1	1
8	9242-453-020	Hose, Cold Valve to Vac. Brkr 18	1	1
9	9242-453-020	Hose, Cold Valve to Tub 18	1	1
*	8654-029-000	Clamp, Hose-Spring (overflow from drain to tub back)	2	2
*	8654-117-009	Clamp, Hose	1	1
10	8654-117-015	Clamp, Hose-Worm	10	10
*	9883-006-001	Injector Assy (PVC)	1	1
*	9242-463-002	Hose, Overflow	1	1
*	9242-462-001	Hose, Injector to Tub	1	1

*Not illustrated

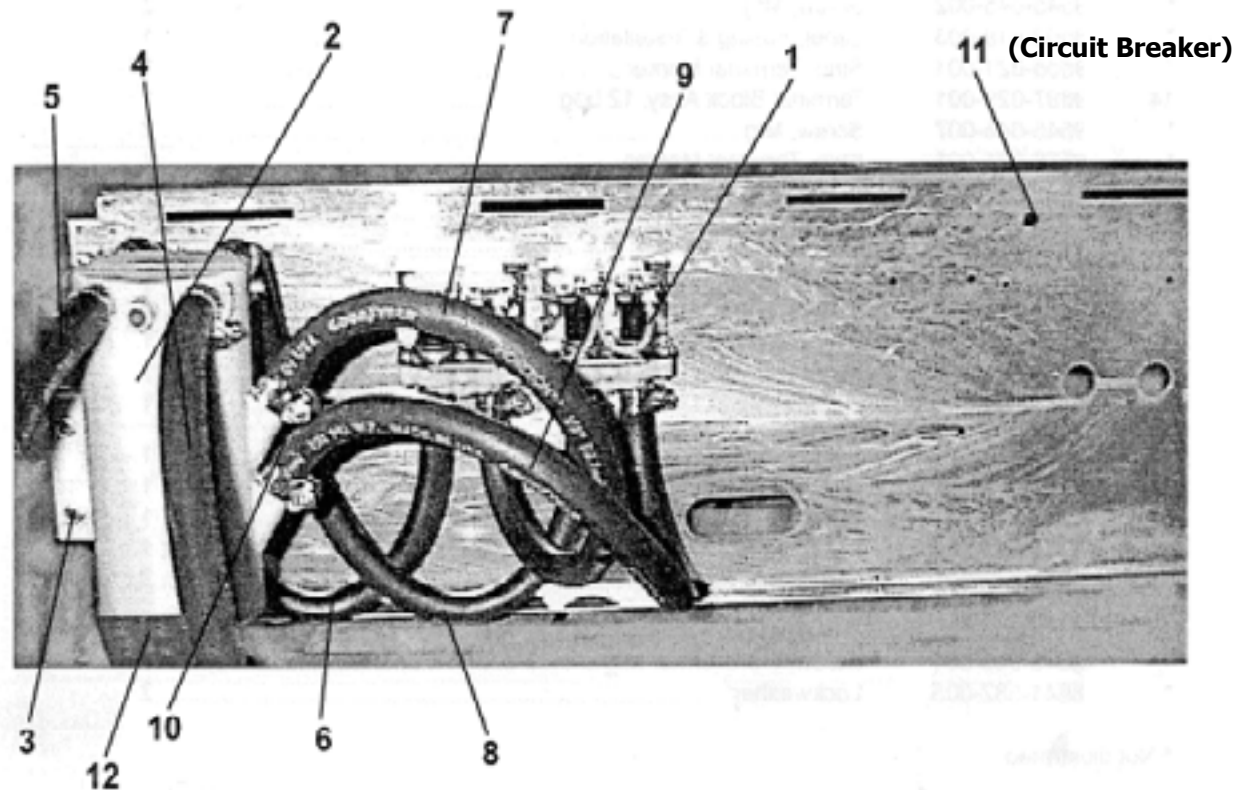

Water Inlet & Rear Channel

Key	Part Number	Description	MODELS WCN40	
			A	A
1	9379-183-003	Valve, Water Inlet (see Water Inlet Valve Breakdown for individual parts)	2	2
*	9545-008-026	Screw, Valve Mtg	4	4
*	8640-399-006	Nut, Spring	4	4
2	9610-001-001	Vacuum Breaker	1	1
*	9029-069-001	Bracket, Vacuum Breaker	1	1
3	9545-008-026	Screw	4	4
4	9242-461-001	Hose, Injector to Vacuum Breaker	1	1
*	8654-117-008	Clamp, Vac. Brkr. End	1	1
*	8654-117-009	Clamp, Tub End	1	1
5	9242-453-008	Hose, Vacuum Breaker to Wash Dispenser 26	1	1
6	9242-453-009	Hose, Vacuum Breaker to Rinse Dispenser 23	1	1
7	9242-453-020	Hose, Hot Valve to Vacuum Breaker 18	1	1
8	9242-453-020	Hose, Hot Valve to Tub 18	1	1
9	9242-453-020	Hose, Cold Valve to Vacuum Breaker 18	1	1
10	9242-453-020	Hose, Cold Valve to Tub 18	1	1
*	9242-462-001	Hose, Injector to Tub	1	1
*	8654-117-015	Clamp, Hose Worm	13	13
*	9883-007-001	Injector Assy PVC	1	1
*	9242-463-003	Hose, Overflow	1	1
*	0935-127-001	End Cap	1	1

* Not Illustrated

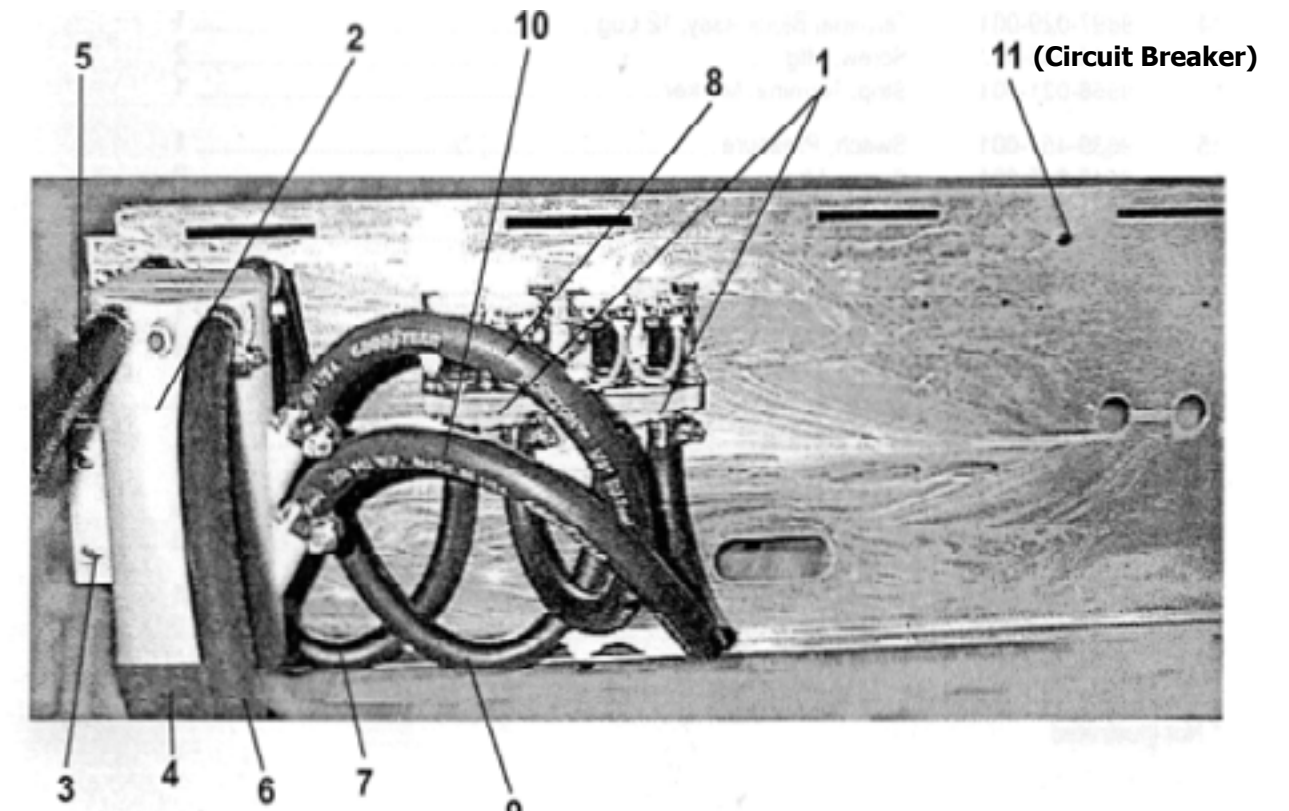

Electrical Components - Top Compartment WCN25AA - Single Phase Only

Key	Part Number	Description	Qty
1	9839-012-003	Trough Assy, Controls Mtg	1
*	9545-008-005	Screw, Trough Sides	2
*	9029-064-001	Bracket, Trough to Rear Channel	1
*	9545-008-001	Screw, Trough Bracket	3
1a	9029-061-001	Front Trough Bracket (control panel to front)	1
2	5191-102-005	Capacitor, Spin-Start (Century) (plastic)	1
3	5191-103-010	Capacitor, Run-Tumble (Century) (metal)	1
4	9544-049-002	Strap, Capacitor Mtg (Century)	1
*	9545-045-001	Screw, Capacitor Strap	2
5	5192-286-007	Relay, RUN	2
6	5192-286-008	Relay, Spin	1
7	9571-361-004	Timer, Program (VERIFY PART NUMBER ON TIMER BODY)	1
*	9376-295-004	Motor, Timer Main Drive	1
*	9376-286-004	Motor, Timer Rapid Advance	1
*	9545-012-001	Screw, Timer Mtg	2
8	9107-067-001	Dial, Timer	1
9	9307-176-001	Knob, Timer (w/set screws)	1
10	9571-360-001	Timer, Reversing	1
*	9545-044-004	Screw, Reversing Timer	2
11	9897-033-002	Terminal Block, Power Connection	1
*	9545-045-007	Screw, Mtg	2
*	8502-619-003	Label, Fusing	1
12	9897-034-001	Terminal Block Assy,	1
*	9545-045-007	Screw, Mtg	2
*	9558-022-001	Strip, Terminal Marker	1
13	5192-285-001	Relays	2
14	9539-489-001	Switch, Pressure	1
*	9545-045-001	Screw, Mtg	2
*	5198-211-004	Circuit Breaker, 1.5 amp	1
*	8652-130-037	Lug, Grounding	1
*	8639-621-007	Screw, Mtg	1
*	8641-582-006	Lockwasher	1
16	9539-478-002	Solid State Start Switch	1
*	9029-062-001	Strap, Mtg	1
*	9545-010-001	Screw	1
*	8640-412-005	Nut	1
*	9545-031-003	Screw	1

* Not Illustrated

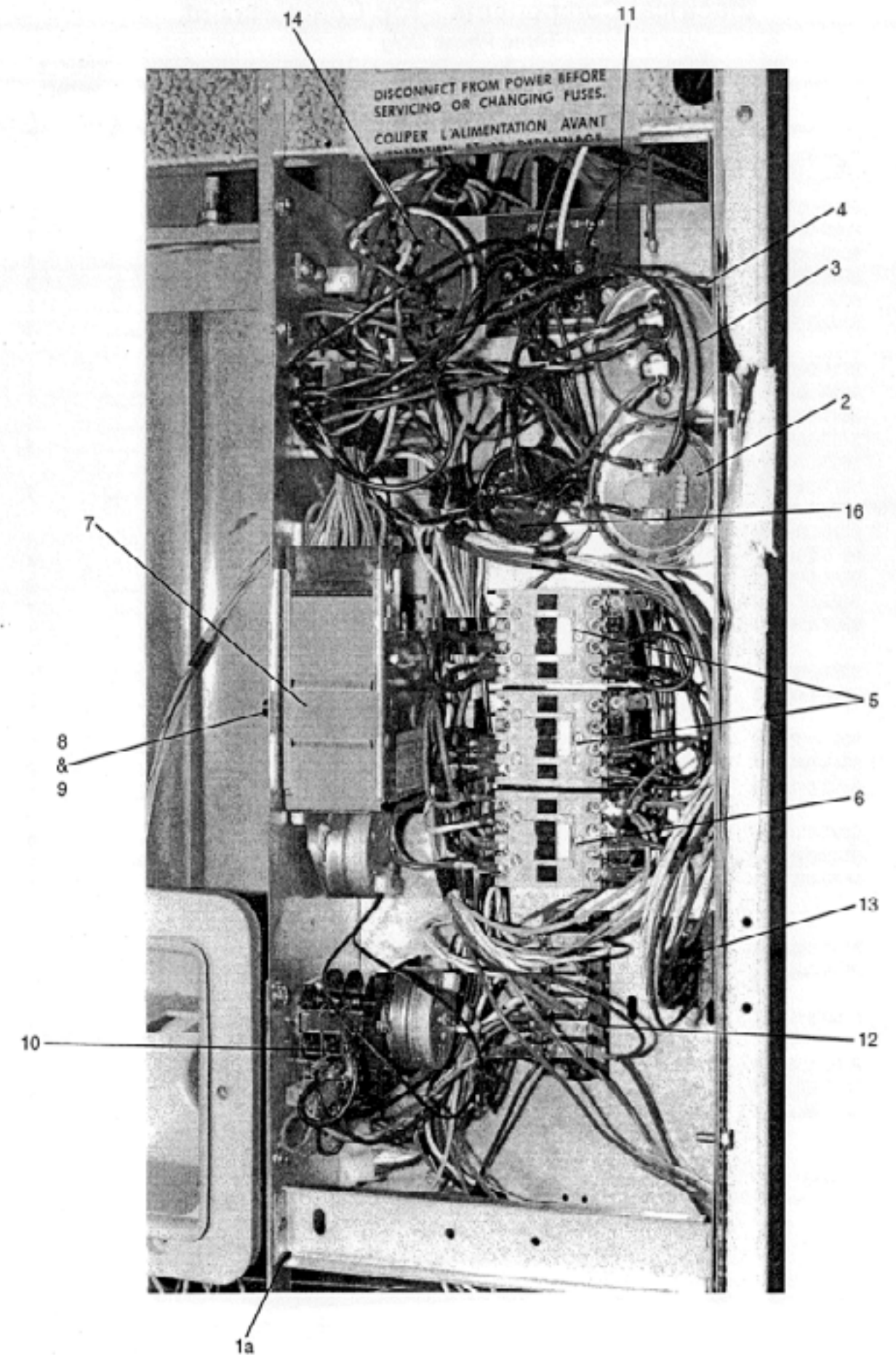

Electrical Components - Top Compartment WCN25AB - Three Phase Only

Key	Part Number	Description	Qty
1	9839-012-003	Trough Assy, Controls Mtg	1
*	9545-008-026	Screw, Trough Sides	2
1a	9029-064-001	Bracket, Trough to Rear Channel	1
1b	9029-061-001	Bracket, Trough to Front Channel	1
*	9545-008-026	Screw, Trough Bracket	3
2	5192-286-007	Relay, Tumble	2
3	5192-286-009	Relay, Spin	1
4	8711-004 001	Transformer,Control	1
*	9545-008-026	Screw, Mtg	1
*	8641-582-006	Lockwasher	1
4a	5192-285-001	Relay,small clear	1
*	8653-074-001	Connector	1
5	9571-361-004	Timer, Program	1
	(VERIFY PART NUMBER ON TIMI;R BODY.)		
*	9376-295-004	Motor, Timer Main Drive	1
*	9376-286-004	Motor, Timer Rapid Advance	1
*	9545-012-001	Screw, Timer Mtg.	2
*	9107-067-002	Dial, Timer	1
*	9307-176-001	Knob, Timer (w/set screws)	1
6	9571-360-001	Timer, Reversing	1
*	9545-044-004	Screw, Reversing Timer	2
7	9897-035-002	Terminal Block, Power Connection	1
*	9545-045-007	Screw, Mtg	2
*	8502-619-004	Label, Fusing	1
8	9897-034-001	Terminal Block Assy, 12 Lug	1
*	9545-045-007	Screw, Mtg	2
*	9558-022-001	Strip, Terminal. Marker	1
10	9539-489-001	Switch, Pressure	1
*	9545-045-001	Screw, Mtg	2
*	5198-211-004	Circuit Breaker, 1.5 amp	1
*	8652-130-037	Lug, Grounding	1
*	8639-621-007	Screw, Mtg	1
*	8641-582-006	Lockwasher	1

*Not illustrated

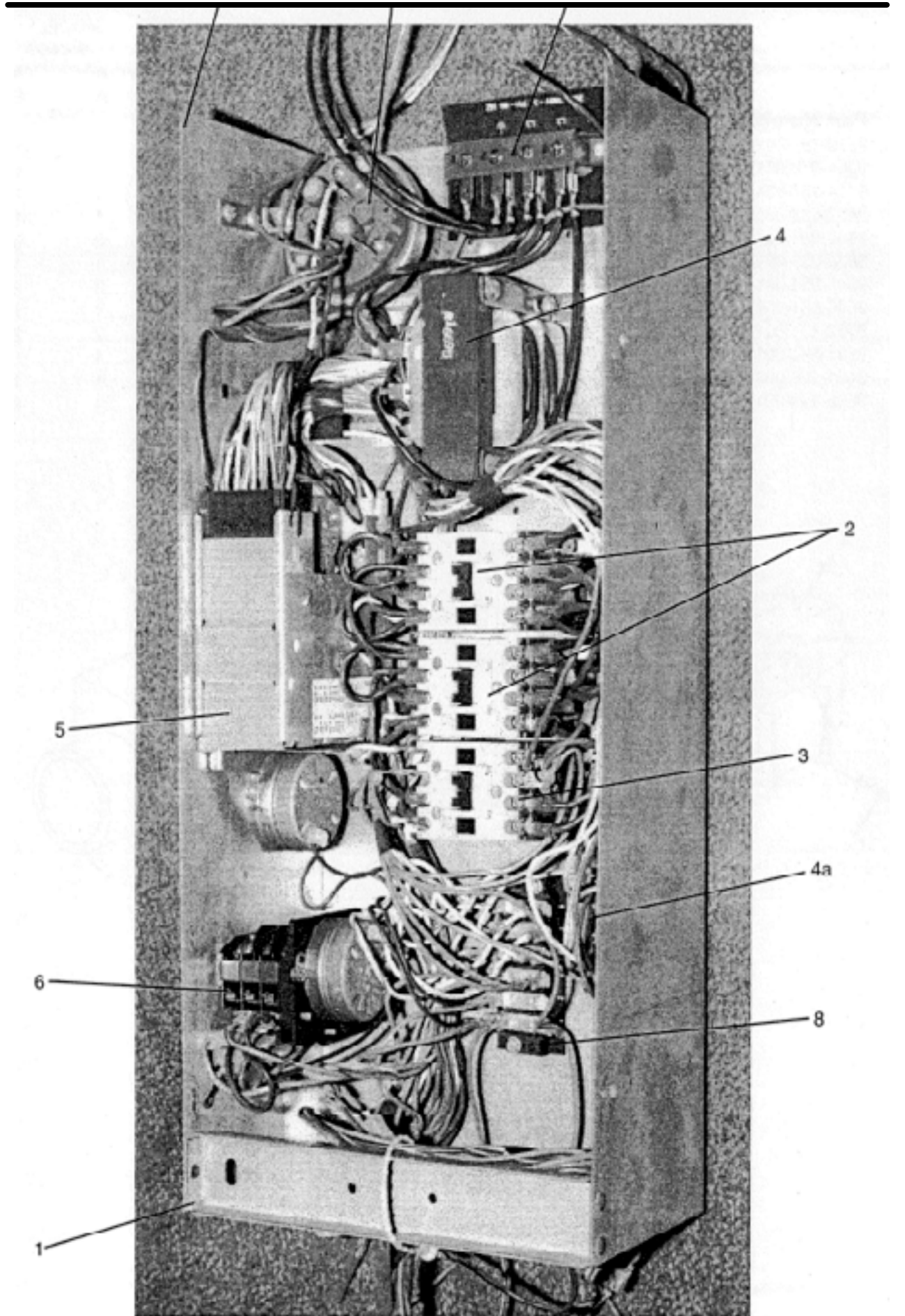

Electrical Components - Top Compartment WCN40AA - Single Phase Only

Key	Part Number	Description	Qty
1	9839-012-003	Trough Assy, Controls Mtg	1
*	9003-229-001	Angle, Trough to Rear Channel	1
*	9545-008-026	Screw	4
*	9029-061-001	Front Bracket (mounting to control panel)	1
2	5191-102-006	Capacitor, Spin-Start (plastic)	1
3	5191-103-009	Capacitor, Run-Tumble (metal)	1
4	9544-054-001	Strap, Capacitor Mtg	1
*	9545-045-001	Screw, Capacitor Strap	2
5	5192-285-001	Relay, (small)	2
.6	5192-286-007	Relay, Tumble	2
7	5192-286-008	Relay, Spin	1
8	9571-361-004	Timer, Program (VERIFY PART NUMBER ON TIMER BODY)	1
*	9376-295-004	Motor, Timer Main Drive	1
*	9376-286-004	Motor, Timer Rapid Advance	1
*	9545-012-001	Screw, Timer,Mtg	2
9	9107-067-001	Dial, Timer	1
10	9307-176-001	Knob, Timer (w/set screws)	1
11	9571-360-001	Timer, Reversing	1
*	9545-044-004	Screw, Reversing Timer	2
12	9897-033-002	Terminal Block, Power Connection	1
*	9545-045-007	Screw, Mtg	2
*	8502-619-003	label, Fusing	1
13	9897.:029-001	Terminal BlockAssy, 12 Lug	1
*	9545-045-007	Screw, Mtg	2
*	9558-022-001	Strip, Terminal Marker	1
14	9539-489-001	Switch, Pressure	1
*	9545-045-001	Screw, Mtg	2
*	5198-211-004	Circuit Breaker, 1.5 amp	1
15	8652-130-037	Lug, Grounding	1
*	8639-621-007	Screw,. Mtg	1
*	8641-582-006	lockwasher	1
16	9539-478-002	Solid State Start Switch	1
*	9029-062-001	Strap, Mtg.	1
*	9545-010-001	Screw	1
*	8640-412-005	Nut	1
*	9545-031-003	Screw	1

* Not Illustrated

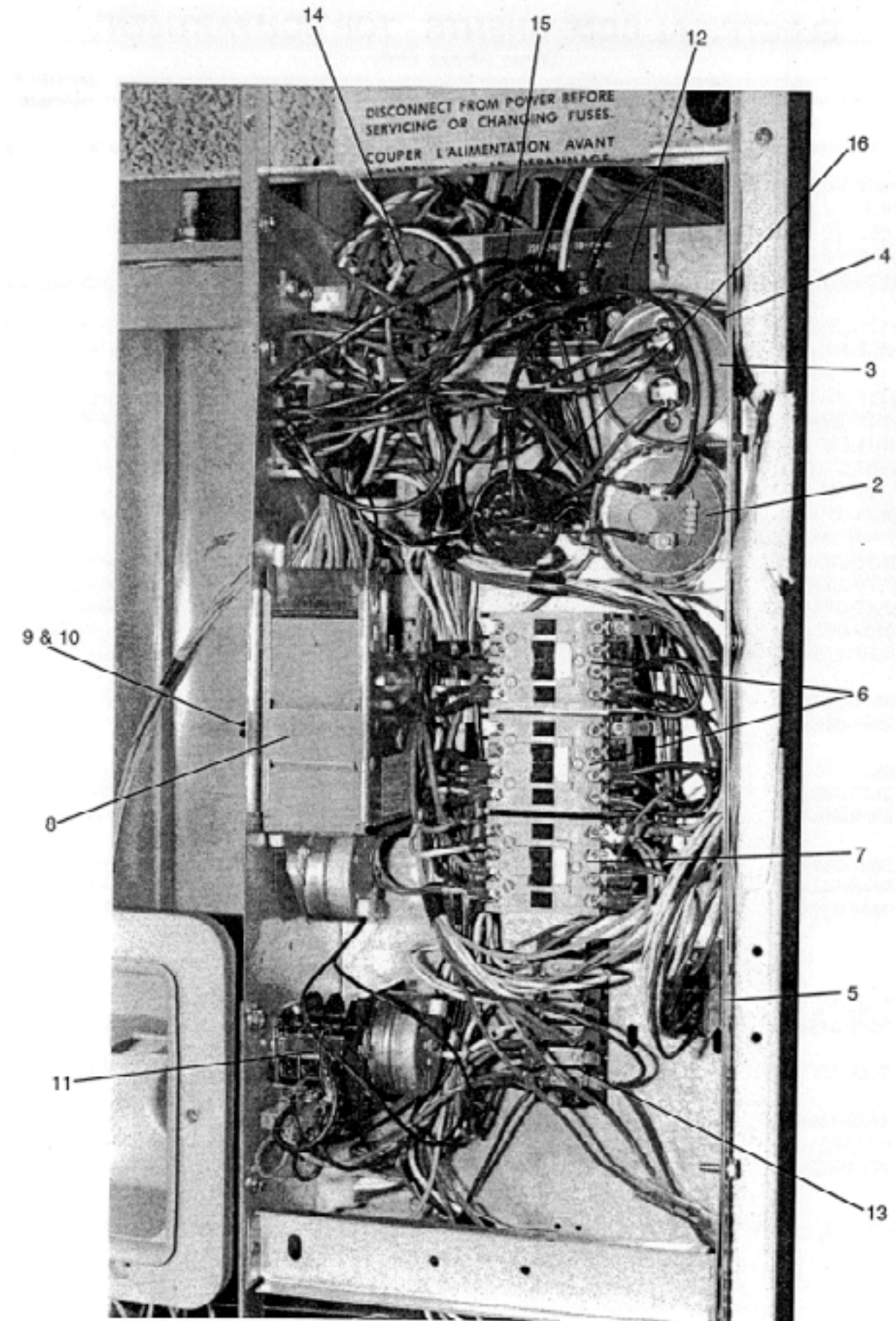

Electrical Components - Top Compartment WCN40AB - Three Phase Only

Key	Part Number	Description	Qty
1	9839-012-003	Trough Assy, Controls Mtg	1
*	9003-229-001	Angle, Trough to Rear Channel	1
*	9545-008-026	Screw	4
*	9029-061-001	Front Bracket (mounting to control panel)	1
2	5192-286-007	Relay, Tumble	2
3	5192-286-009	Relay, Spin	1
4	8711-004-001	Transformer, Control	1
*	9545-008-026	Screw	1
*	8641-582-006	Lockwasher	1
*	8653-074 001	Connector	1
4a	5192-285-001	Relay Small	
5	9571-361-004	Timer, Program (VERIFY PART NUMBER ON TIMER BODY)	1
*	9376-295-004	Motor, Timer Main Drive	1
*	9376-286-004	Motor, Timer Rapid Advance	1
*	9545-012-001	Screw, Timer Mtg	2
*	9107-067-00j	Dial, Timer Decal	1
*	9307-176-001	Knob, Timer (w/set screws)	1
6	9571-360-001	Timer, Reversing	1
*	9545-044-004	Screw, Reversing Timer Mtg	2
7	9897-035-002	Terminal Block, Power Connection	1
*	9545-045-007	Screw, Mtg	2
*	8502-619-004	Label, Fusing	1
8	9897-034-001	Terminal Block Assy, 12 Lug	1
*	9545-045-007	Screw, Mtg	2
*	9558-022-001	Strip, Terminal Marker	1
9	9539-489-001	Switch, Pressure	1
*	9545-045-001	Screw, Mtg	2
*	5198-211-004	Circuit Breaker, 1.5 amp	1
*	8652-130-037	Lug, Grounding	1
*	8639-621-007	Screw, Mtg	1
*	8641-582-006	Lockwasher	1

*Not illustrated

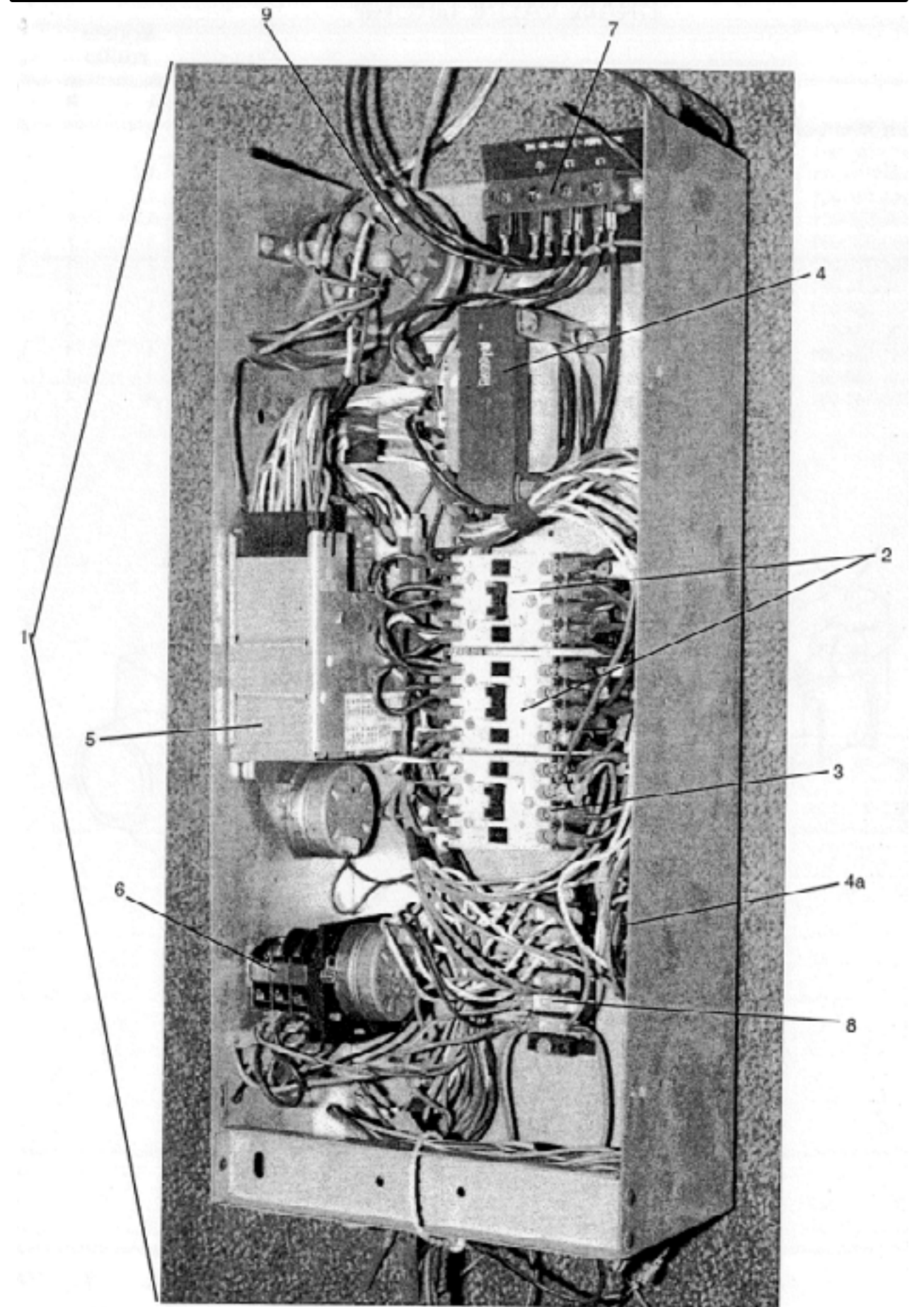

Control Panel Part # by Model

Key	Part Number	Description	Qty
1	9539-474-004	Switch, Red--OFF/ON	1
2	9539-474-005	Switch, White--ADVANCE/START	1
3	9539-474-006	Switch, Blue--PAUSE/RUN	1
4	9539-471-001	Switch, Rotary Selector	1
6	9539-479-007	Switch, Push-button (cycle selector) (WCN40)	1
6	9539-479-005	Switch, Push-button (cycle selector) (WCN25)	1
5	9307-176-001	Knob, Control	1
	9545-044-004	Screw, 6-32 x 1/4"	1
7	9412-096-002	Nameplate MAXILOAD (WCN40)	1
7	9412-095-002	Nameplate MULTILOAD (WCN25)	1
*	9538-165-001	Spacer	2
*	8640-412-003	Nut; Switch mounting	2
8	3310-041-001	Light, Cycle Control	1
9	9206-100-001	Gasket, Light	2
10	9989-458-001	Panel Assembly --Control	1

*Not illustrated

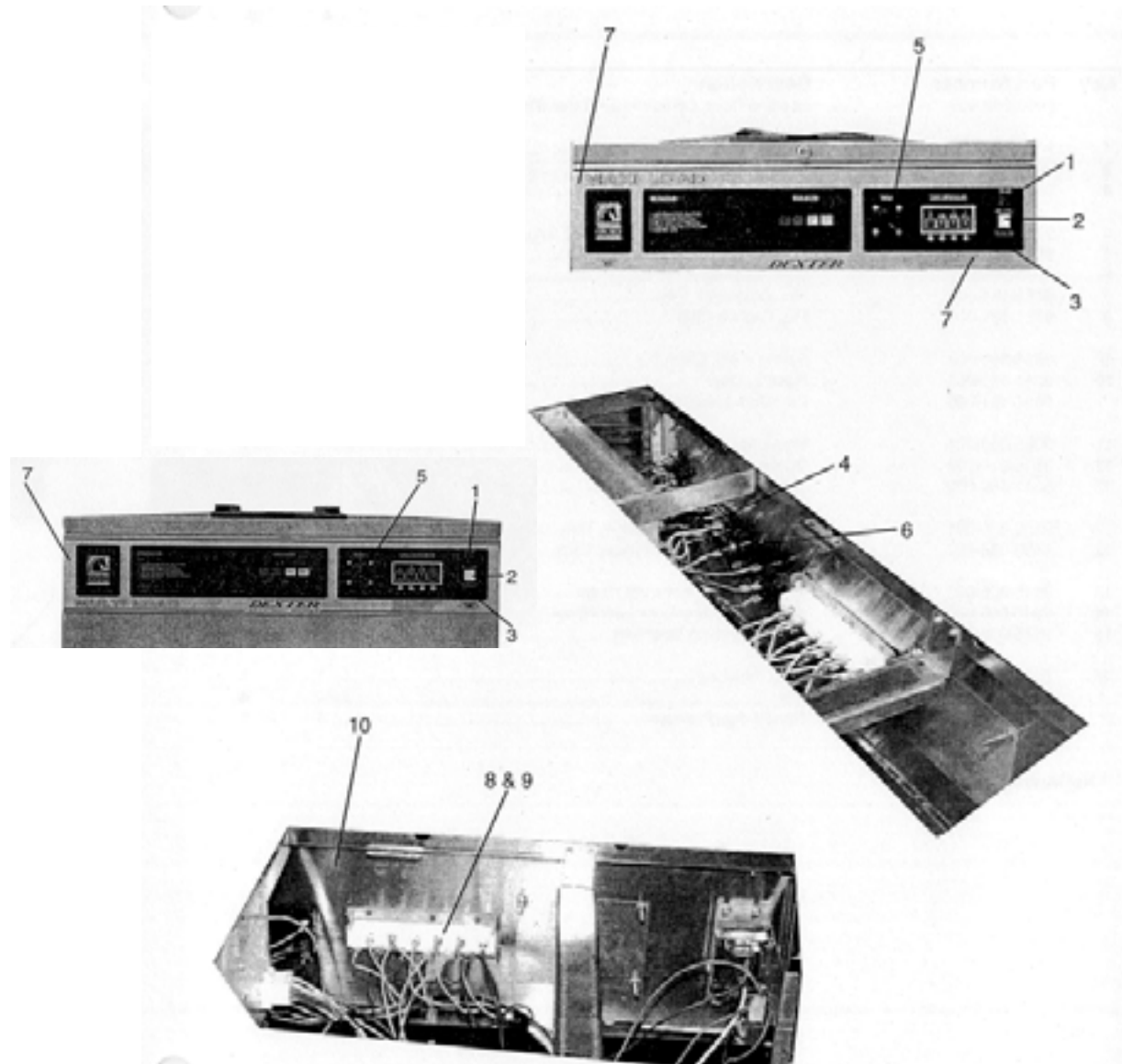

Labels and Diagrams WCN Models

9345-783-002	Label Main timer(chart)
9345-794-002	Wiring Label-Schematic
9345-796-004	Wiring Label-Diagram
8502-624-002	Label Warning Door Opening
8502-614-004	Label High Voltage
8502-647-001	Label Connections Injector
8502-666-001	Label Injector Assembly 1
8502-649-001	Label Connections Electrical
8502-619-003	Label Fusing & Installation
9345-795-003	Wiring Diagram (3 PH)

Section 8:

Maintenance

Preventative Maintenance

Daily

- Step 1:** Check that the loading door remains securely locked and cannot be opened during an entire cycle.
- Step 2:** Clean the top, front, and sides of the cabinet to remove residue.
- Step 3:** Clean the soap dispenser and lid and check that all dispenser mounting screws are in-place and tight.
- Step 4:** Check the loading door for leaks. Clean the door seal of all foreign matter.
- Step 5:** Leave the loading door open to aerate the washer when not in use.

Quarterly

- Step 1:** Make sure the washer is inoperative by switching off the main power supply.
- Step 2:** Check the V-belts for wear and proper tension.
- Step 3:** Clean lint and other foreign matter from around motor.
- Step 4:** Check all water connections for leaks.
- Step 5:** Check the drain valve for leaking and that it opens properly.
- Step 6:** Wipe and clean the inside of the washer and check that all electrical components are free of moisture and dust.
- Step 7:** Remove and clean water inlet hose filters. Replace if necessary.
- Step 8:** Check anchor bolts. Retighten if necessary.