



DEXTER[®]
LAUNDRY

**USE THE BLUE TABS LOCATED ON THE
RIGHT AND LEFT SIDES OF THE FOLLOWING
DOCUMENT TO ADVANCE TO EACH SECTION.**

V-Series Accessories

*WCVD45HC_-12SZ 208-240 volts 60hz. Single Phase or Three Phase
(Parts differences for the regular door T650 will be found on pages 104-105)

WCVD50HC_-12SZ 208-240 volts 60hz. Single Phase or Three Phase
WCVD60HC_-12 208-240 volts 60hz Single Phase or Three Phase
WCVD60HC_-12SZ 208-240 volts 60hz Single Phase or Three Phase
WCVD80HC_-12 208-240-volts 60hz Single Phase or Three Phase
WCVD90HC_-12SZ 208-240 volts 60 hz Single Phase or Three Phase

Key	Description	T750	T-900	T950	T-1200	T1450	QTY
*	Hose, Water Supply 3/8" I.D. x 48"						2
*	Hose, Water Supply 5/8" I.D. x 48"	9990-027-013	9990-027-013	9990-027-013			2
	Hose, Water Supply 5/8" I.D. x 48"				9990-027-013	9990-027-013	4
*	Washer, Inlet Hose (furnished)	8641-242-000	8641-242-000	8641-242-000	8641-242-000	8641-242-000	2
*	Strainer, Inlet Hose (furnished)	9565-003-001	9565-003-001	9565-003-001	9565-003-001	9565-003-001	2
*	Bevel Washer for 5/8" bolt used in installations using angle iron bases		8641-586-002		8641-586-002		
*	Bevel Washer for 3/4" bolt used in installations using angle iron bases	8641-586-003	8641-586-003	8641-586-003	8641-586-003	8641-586-003	4
*	Sealing compound	8538-151-001	8538-151-001	8538-151-001	8538-151-001	8538-151-001	1
*	TORX#20	8545-051-002	8545-051-002	8545-051-002	8545-051-002	8545-051-002	1
*	Special Tool For Removing Coin Acceptor Mounting Screws. (T-10 Torx)	8545-051-003	8545-051-003	8545-051-003	8545-051-003	8545-051-003	1
*	Flow Restrictors (in dispenser)	9475-002-002	9475-002-002	9475-002-003	9475-002-003	9475-002-003	2
*	Battery (used on Control PCB)	8612-001-001	8612-001-001	8612-001-001	8612-001-001	8612-001-001	1
*	Special Tool for adjusting spacing between outer tub front and cylinder front	8545-056-001	8545-056-001	8545-056-001	8545-056-001	8545-056-001	1
*	VFD Filter options (1 phase) 120v						1
*	VFD Filter options (3 phase)	9732-255-001	9732-255-001	9732-255-001	9732-256-001	9732-255-001	1
*	VFD Filter options (1 phase)	9732-230-001	9732-230-001	9732-230-001	9732-251-001	9732-230-001	1
*	Puller for pushing cylinder out of bearings must be purchased from local sources.						1
*	Clamps to hold tub front to outer tub when installing tub front	Vise Grip #11R	Vise Grip #11R	Vise Grip #11R	Vise Grip #11R	Vise Grip #11R	1
*	Coin Bearing & Seal Kit	9732-219-006	9732-219-006	9732-219-006	9732-219-006	9732-219-006	1
*	Coin Op CD with OS2 Platform for A Series Washers Only		9504-015-001		9504-015-001		
	Key Service Lock (6324)	6292-006-007	6292-006-007	6292-006-007	6292-006-007	6292-006-007	1
	Key, Program (N561)	6292-006-013	6292-006-013	6292-006-013	6292-006-013	6292-006-013	1
*	Mode Light Support	9635-022-001	9635-022-001	9635-022-001	9635-022-001	9635-022-001	1
*	MS300 VFD Display	9150-058-001	9150-058-001	9150-058-001	9150-058-001	9150-058-001	1

Kits, Assemblies, & Common Parts

Loading Door & Door Lock Components	Part Number
Door Glass Gasket (Large Door)	9206-431-001
Door Glass Gasket (Standard Door)	9206-419-001
Door Handle Only (Small)	9244-080-003
Door Close Switch	9539-492-001
Door Lock Gear Motor Assembly	9892-015-001
Kit - Door Latching Assy. & Cam (replaces original Door Latching Assembly)	9732-347-001
Kit - Door Cam Replacement	9732-346-002
Kit - Locking Pawl Replacement	9732-346-001
Kit - Door Gasket Expander Kit (Small)	9732-139-001
Kit - Door Gasket Expander Kit (Large)	9732-139-002
Electrical Components	Part Number
Transformer, Main	8711-004-001
Transformer, Control	8711-009-001
Main Control Board	9473-004-009
Kit, Electronic Pressure Sensor	9732-314-001
VFD & Breaking Resistors Components	Part Number
Breaking Resistor 200 Ohms	9483-004-002
Breaking Resistor 160 Ohms	9483-004-003
Delta E Drive Display	9150-044-001
MS 300 VFD Display	9150-058-001
Data Cable (56")	9806-015-003
Drain & Water Valve Components	Part Number
Kit - 3" Drain Valve Seal Replacement	9732-327-001
Drain Valve 3"	9379-202-001
Water Valve (Dual)	9379-183-012
Water Valve (Single Mueller)	9379-194-001
Diaphragm (Dual)	9118-049-003
Diaphragm (Single Mueller)	9118-055-001
Cabinet Components	Part Number
Front Panel Screw	9545-008-014
Front Panel Finisher Washer	8641-585-001
Front Panel Spring Nut	8640-399-008
Top Soap Box Screw (Regular Chassis Only)	9545-008-012
Top Soap Box Spring Nut (Regular Chassis Only)	8640-399-007
5/16 Hex Screw, Common	9545-008-026
Top Lock Key #6324	9306-025-001
Cylinder Plug (1.5" Plastic)	9456-041-007



Section 8:

Parts Data

*WCVD45HC_-12SZ 208-240 volts 60hz. Single Phase or Three Phase
(Parts differences for the regular door T650 will be found on pages 104-105)

WCVD50HC_-12SZ 208-240 volts 60hz. Single Phase or Three Phase
 WCVD60HC_-12 208-240 volts 60hz Single Phase or Three Phase
 WCVD60HC_-12SZ 208-240 volts 60hz Single Phase or Three Phase
 WCVD80HC_-12 208-240-volts 60hz Single Phase or Three Phase
 WCVD90HC_-12SZ 208-240 volts 60 hz Single Phase or Three Phase

Wiring Harness Part # by Model

Key	Description	T750	T-900	T950	T-1200	T1450	QTY
*	Wiring Harness (Add Bleach Lite assy included)	9794-001-001	9794-001-001	9794-001-001	9794-001-001	9794-001-001	1
*	Wiring Harness, Door Lock	9627-791-005	9627-791-005	9627-791-005	9627-791-005	9627-791-005	1
*							
*	Wiring Harness, Drain,Thermo,DoorSol	9627-796-002	9627-796-002	9627-796-002	9627-796-002	9627-796-002	1
*	Data Cable	9806-015-001	9806-015-001	9806-015-001	9806-015-003	9806-015-003	1
*	Wiring Harness P20/P21	9627-793-001	9627-793-001	9627-793-001	9627-793-001	9627-793-001	1
*	Wiring Harness P8/P16	9627-794-001	9627-794-001	9627-794-001	9627-794-001	9627-794-001	1
*	Wiring Harness WaterValve/P19	9627-795-004	9627-795-004	9627-795-004	9627-795-004	9627-795-004	1
*	Wiring Harness LED PCB	9627-797-001	9627-797-001	9627-797-001	9627-797-001	9627-797-001	1
*	Wiring Harness P5/pressure	9627-807-001	9627-803-001	9627-803-001	9627-803-001	9627-899-001	1
*	Wiring Assembly Yel. 32"		8220-064-023	8220-064-023			2
*	Wiring Assembly Yel. 64"				8220-064-040	8220-064-040	2
*	Wiring Assembly Red 23" #8	8220-063-028					1
*	Wiring Assembly Red 41"				8220-062-032	8220-062-032	2
*	Wiring Assembly Vio. 24"				8220-118-001	8220-118-001	2
*	Wiring Assembly Wht/Brn 8"				8220-108-007	8220-108-007	1
*	Wiring Assembly Jumper Yel	8220-123-001	8220-123-001	8220-123-001	8220-128-001	8220-128-001	1
*	Wire Red Yellow 8"				8220-108-008	8220-108-008	1
*	Wire Yellow Jumper (water valve)				8220-119-002	8220-119-002	1
*	80lb Washer Dispenser Label				8502-687-001	8502-687-001	1
*	Wiring Assembly Red 28" #24	8220-062-025	8220-062-025	8220-062-025			2
*	Wiring Assembly Blk. 17"		8220-062-028	8220-062-028	8220-062-028	8220-062-028	1
*	Wiring Assembly Red 17"		8220-062-027	8220-062-027	8220-062-027	8220-062-027	1
*	Wiring Assembly Jumper BLK.	8220-117-002	8220-117-002	8220-117-002	8220-117-003	8220-117-003	2
*	Wiring Assembly Red 7" #36	9631-381-018	9631-381-018	9631-381-018	9631-381-018	9631-381-018	1
*	Wiring Assembly Blu/Wht	8220-090-009	8220-090-009	8220-090-009	8220-090-009	8220-090-009	1
*	Wiring Assembly Blk/Blu	8220-001-231	8220-001-231	8220-001-231	8220-001-231	8220-001-231	1
*	Wire Assembly Green 7"						1
*	Wire Assembly BLK. 23" #8	8220-063-029					
*	Harness Power Terminal Block	9627-747-003	9627-747-002	9627-747-002	9627-747-002	9627-747-002	1

Cabinet and Front Panel Group Part # by Model Large Door Before Serial # 535659

Key	Description	T750	T-900	T950	T-1200	T1450	QTY
1	Panel, Side (Left or Right) - stainless	9454-812-001					2
1	Panel, Side (Left or Right) - stainless		9454-813-001		9732-359-003		4
*	Bolt-1/4-20x1/2 (side panel Front to Rear)		9545-018-013		9545-018-013	9545-018-013	8
*	Nut 1/4-20UNC (side panel)		8640-414-006		8640-414-006	8640-414-006	8
*	Strap Assy (Side to base)	9966-013-001					2
*	Strap Assy (Side to base)		9966-012-001		9966-012-002		4
*	Shim (side panel to base)	9552-041-001	9552-039-001		9552-039-001		2
*	Nut, Hex 1/4-20 UNC (for strap assembly to base)	8640-414-006					6
*	Nut, Hex 1/4-20 UNC (for strap to base)		8640-414-006		8640-414-006		8
2	Bracket, Side Panel under front panel	9046-085-001	9046-085-001		9046-085-001		1
*	Screw #10Bx1/2 side panel brkt	9545-008-026					1
*	Nut 1/4-20 UNC side panel brkt	8640-414-006					1
*	Nut, Hex		8640-413-002		8640-413-002		2
*	Screw		9545-008-024		9545-008-024		2
3	Panel Assy, Front	9454-810-002	9454-810-002		9989-618-003		1
*	Band, Edge Protector	9578-072-002					1
4	Bumper Loading Door	9051-055-001	9051-055-001		9051-055-001		1
*	Nut, 1/4 x 20 for bumper	8640-414-006	8643-414-006		8643-414-006		1
*	Screw, Hex- To Control Panel	9545-008-024	9545-008-024		9545-008-024		2
*	Nut, Spring- To Control Panel 10/32	8640-442-001	8640-442-001		8640-442-001		2
5	Screw, Flat Head- Front to Sides	9545-008-014	9545-008-014				2
5	Screw, Flat Head- Front to Sides				9545-008-014		4
6	Washer, Finish	8641-585-001	8641-585-001				2
6	Washer, Finish				8641-585-001		4
*	Nut, Spring-To Front Panel	8640-442-001	8640-442-001		8640-442-001		2
7	Label, Door Opening (Blue)	8502-723-001	8502-723-001		8502-723-001		1
7	Label, Door Opening (Black)	8502-742-001	8502-742-001		8502-742-001		1
8	Panel, Control (Mounts Name-plate)	9989-480-001	9989-480-001		9989-480-001		1
*	Screw, Control Panel to Sides	9545-008-026	9545-008-026		9545-008-026		4
9	Nameplate Decal, Control Blue	9412-163-001	9412-119-001		9412-134-001		1
9	Nameplate Decal, Control Black	9412-185-001	9412-186-001		9412-189-001		1
10	Panel Top	9454-743-001	9454-736-001				1
11A	Panel Top Front				9454-761-001		1
11B	Panel Top Rear				9454-762-001		1
12	Lock, Top (w/Key)	8650-012-003	8650-012-003		8650-012-003		2
13	Door, Lower Service W/Handle	9960-286-004	9960-286-004		9960-286-004		1
14	Handle (bumper guard)	9244-086-003	9244-086-003		9244-086-003		1
*	Rivet Blind 3/16" Alum		9491-009-003		9491-009-003		4
*	Screw		9545-045-010		9545-045-010		4

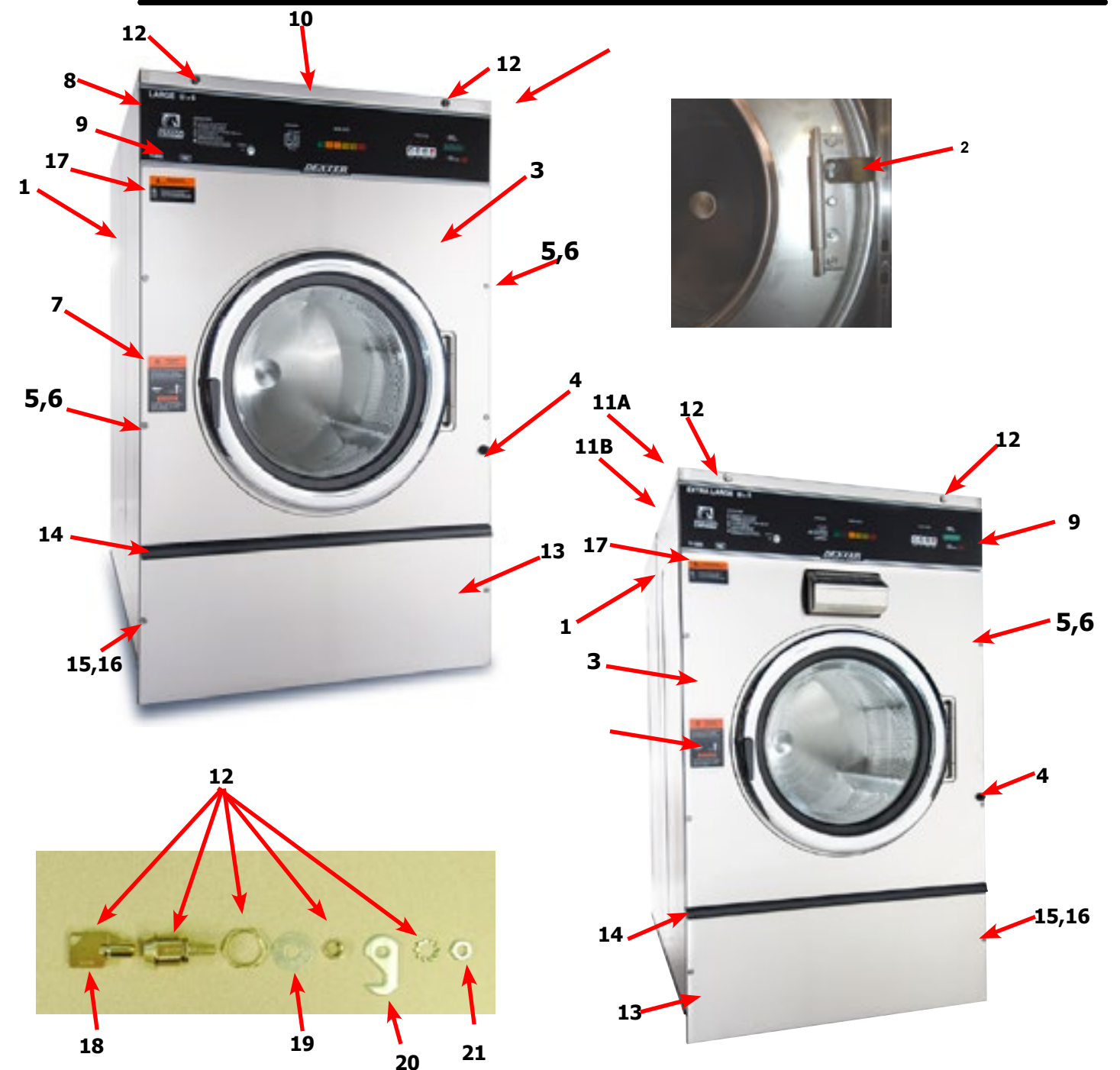

Key	Description	T-750	T-900	T950	T-1200	T1450	QTY
15	Screw Mtg., Flat Head 10Bx1 3/4	9545-008-014	9545-008-014		9545-008-014		2
16	Washer, Finish	8641-585-001	8641-585-001		8641-585-001		2
*	Nut, Spring	8640-399-008	8640-399-008		8640-399-008		2
17	Label-Risk of injury (Blue)	8507-722-002	8507-722-002		8507-722-002		1
17	Label-Risk of injury (Black)	8507-741-001	8507-741-001		8507-741-001		1
18	Key, Top- # 6324	6292-006-007	6292-006-007		6292-006-007		1
19	Washer Flat 5/16	8641-581-008	8641-581-008		8641-581-008		1
20	Cam, Lock-Top	9095-038-001	9095-038-001		9095-038-001		1
21	Nut, 9/32 - 28 Hex	8640-426-001	8640-426-001		8640-426-001		1
							1

Cabinet and Front Panel Group Part # by Model Large Door After Serial # 535659

Key	Description	T-750	T-900	T950	T-1200	T1450	QTY
1	Panel, Side (Left or Right) - stainless	9454-812-001					2
1	Panel, Side (Left or Right) - stainless		9732-359-002	9732-359-002	9732-359-003	9732-359-004	4
*	Bolt-1/4-20x1/2 (side panel Front to Rear)		9545-018-013	9545-018-013	9545-018-013	9545-018-013	8
	Nut 1/4-20UNC (side panel)		8640-414-006	8640-414-006	8640-414-006	8640-414-006	8
	Strap Assy (Side to base)	9966-013-001					2
	Strap Assy (Side to base)		9966-012-001	9966-012-001	9966-012-002	9966-012-001	4
*	Shim (side panel)	9552-041-001	9552-039-001	9552-039-001	9552-042-001	9552-044-001	2
*	Nut, Hex 1/4-20 UNC (for strap assembly)	8640-414-006					6
*	Nut, Hex 1/4-20 UNC		8640-414-006	8640-414-006	8640-414-006	8640-414-006	8
2	Bracket, Side Panel under front panel	9046-085-001	9046-085-001	9046-085-001	9046-085-001	9046-086-001	1
*	Screw #10Bx1/2 side panel brkt	9545-008-026	9545-008-026	9545-008-026	9545-008-026	9545-008-026	1
*	Nut 1/4-20 UNC side panel brkt	8640-414-006	8640-414-006	8640-414-006	8640-414-006	8640-414-006	1
•	Nut, Hex		8640-413-002	8640-413-002	8640-413-002	8640-414-006	2
*	Screw		9545-008-024	9545-008-024	9545-008-024	9545-008-026	2
3	Panel Assy, Front	9454-810-002	9989-617-003	9989-617-003	9989-618-003	9989-619-003	1
4	Band, Edge Protector	9578-092-002	9578-092-002	9578-092-002	9578-092-002	9578-092-002	1
*	Bumper Loading Door	9051-055-001	9051-055-001	9051-055-001	9051-055-001	9051-055-001	1
*	Nut, 1/4 x 20 for bumper	8640-414-006	8640-414-006	8640-414-006	8640-414-006	8640-414-006	1
*	Screw, Hex- To Control Panel	9545-008-014	9545-008-024	9545-008-024	9545-008-024	9545-008-024	2
*	Nut, Spring- To Control Panel 10/32	8640-442-001	8640-442-001	8640-442-001	8640-442-001	8640-442-001	2
5	Screw, Flat Head- Front to Sides	9545-008-014	9545-008-014	9545-008-014	9545-008-014	9545-008-014	2
6	Washer, Finish	8641-585-001	8641-585-001	8641-585-001	8641-585-001	8641-585-001	2
*	Nut, Spring-To Front Panel	8640-442-001	8640-442-001	8640-442-001	8640-442-001	8640-442-001	2
7	Label, Door Opening (Blue)	8502-723-001	8502-723-001	8502-723-001	8502-723-001	8502-723-001	1
7	Label, Door Opening (Black)	8502-742-001	8502-742-001	8502-742-001	8502-742-001	8502-742-001	1
8	Panel, Control (Mounts Nameplate)	9989-480-001	9989-480-001	9989-480-001	9989-480-001	9989-530-001	1
*	Screw, Control Panel to Sides	9545-008-026	9545-008-026	9545-008-026	9545-008-026	9545-008-026	4
9	Nameplate Decal, Control Blue	9412-163-001	9412-119-001		9412-134-001		1
	Nameplate Decal, Control Black	9412-185-001	9412-186-001	9412-187-001	9412-189-001	9412-195-001	
10	Panel Top	9454-743-001	9454-736-001	9454-736-001			1
11A	Panel Top Front				9454-761-001	9454-850-001	1
11B	Panel Top Rear				9454-762-001	9454-851-001	1
12	Lock, Top (w/Key)	8650-012-003	8650-012-003	8650-012-003	8650-012-003	8650-012-003	2
13	Door, Lower Service, Includes Handle	9960-286-004	9960-286-004	9960-286-004	9960-286-004	9960-???-??? (9108-119-001)	1
14	Handle (bumper guard)	9244-086-003	9244-086-003	9244-086-003	9244-086-003	9244-086-004	1
*	Rivet Blind 3/16" Alum	9491-009-003	9491-009-003	9491-009-003	9491-009-003	9491-009-003	4
*	Screw	9545-045-010	9545-045-010	9545-045-010	9545-045-010	9545-045-010	4

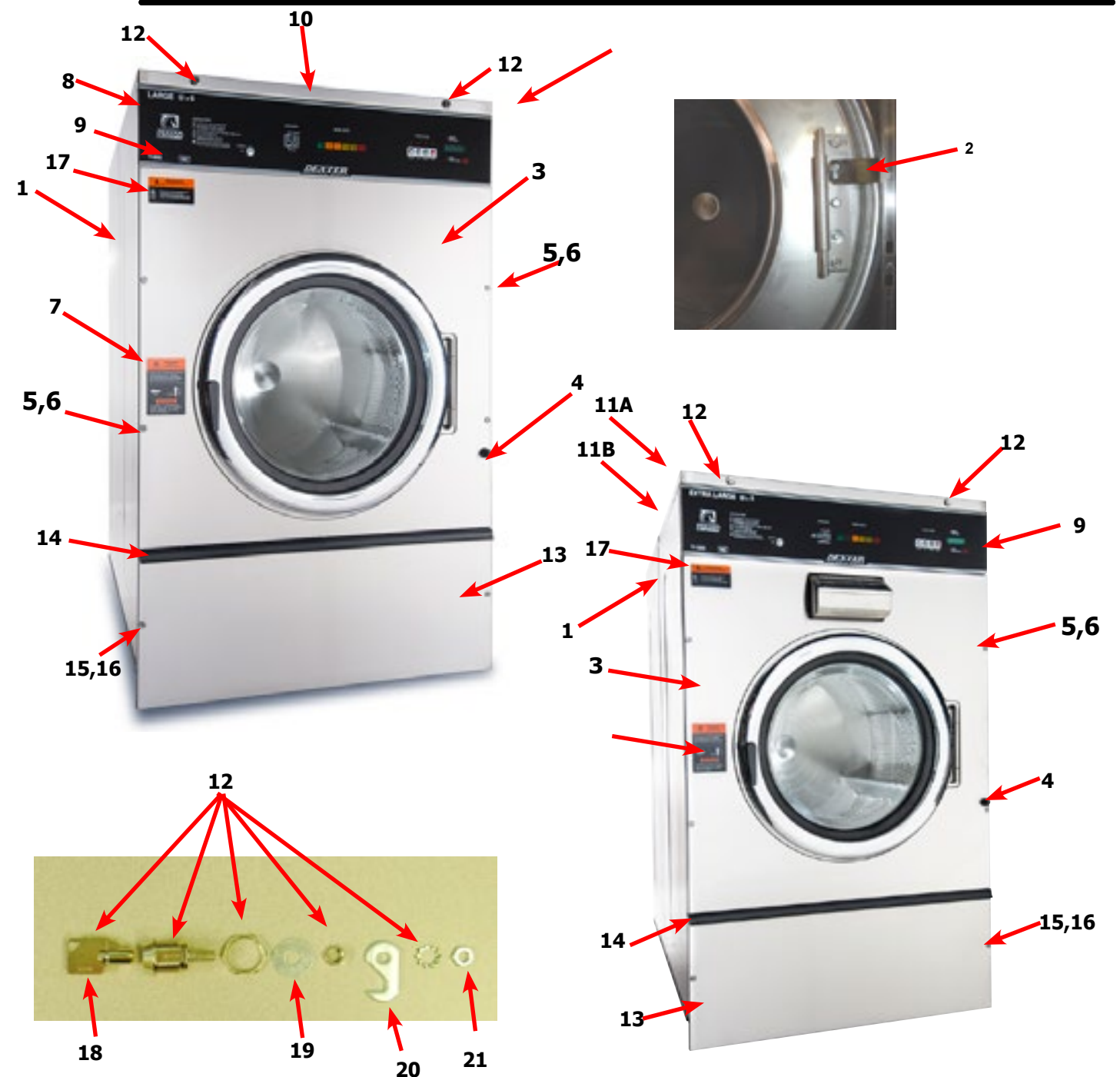

Key	Description	T-750	T-900	T950	T-1200	T1450	QTY
15	Screw Mtg., Flat Head 10Bx1 3/4	9545-008-014	9545-008-014	9545-008-014	9545-008-014	9545-008-014	2
16	Washer, Finish	8641-585-001	8641-585-001	8641-585-001	8641-585-001	8641-585-001	2
*	Nut, Spring	8640-399-008	8640-399-008	8640-399-008	8640-399-008	8640-399-008	2
17	Label-Risk of injury (Blue)	8507-722-002	8507-722-002	8507-722-002	8507-722-002	8507-722-002	1
17	Label-Risk of injury (Black)	8507-741-001	8507-741-001	8507-741-001	8507-741-001	8507-741-001	1
18	Key, Top- # 6324	6292-006-007	6292-006-007	6292-006-007	6292-006-007	6292-006-007	1
19	Washer Flat 5/16	8641-581-008	8641-581-008	8641-581-008	8641-581-008	8641-581-008	1
20	Cam, Lock-Top	9095-038-001	9095-038-001	9095-038-001	9095-038-001	9095-038-001	1
21	Nut, 9/32 - 28 Hex	8640-426-001	8640-426-001	8640-426-001	8640-426-001	8640-426-001	1

Cabinet and Front Panel Group Part # by Model Front Soap Dish

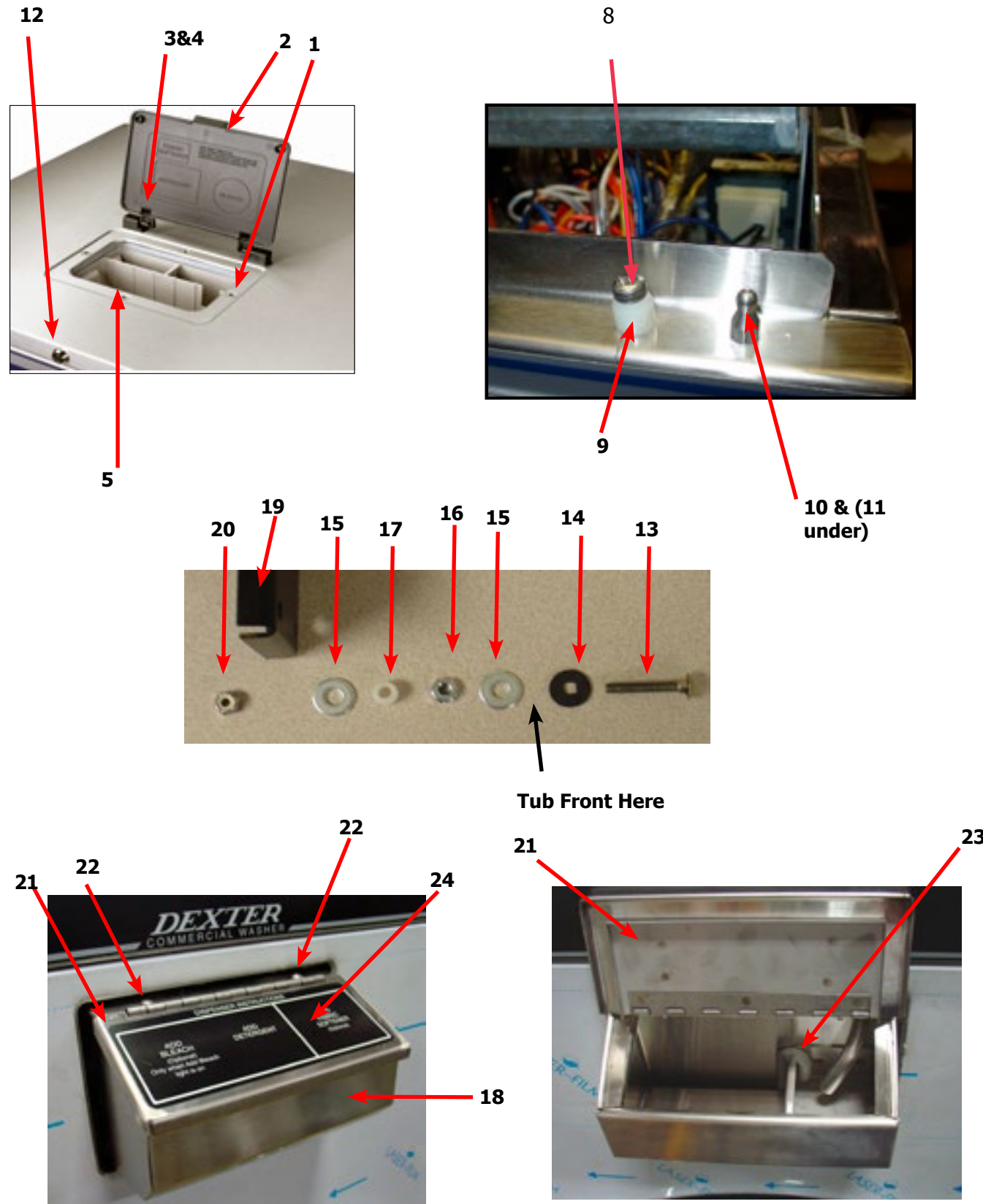

Top Mount Detergent Dispenser

Key	Description	T-750	T-900	T-950	T-1200	T-1450	QTY
1	Dispenser Soap	9122-005-004	9122-005-004				1
*	Nut, Spring ss	8640-399-007	8640-399-007				4
*	Flow restrictors	9475-002-002	9475-002-002				
*	Flow restrictors Optional (Smaller)	9475-002-003	9475-002-003				
2	Door, Dispenser	9108-095-005	9108-095-005				1
3	Pin, Plain	9451-191-001	9451-191-001				2
4	Post, Door Mounting	9467-025-001	9467-025-001				2
5	Screw, SS Dispenser	9545-045-002	9545-045-002				4
*	Washer Flat 5/16	8641-581-008	8641-581-008	8641-581-008	8641-581-008	8641-581-008	1
8	Screw, Locator	9545-008-023	9545-008-023	9545-008-023	9545-008-023	9545-008-023	1
9	Plastic Sleeve, Locator	9355-001-001	9355-001-001	9355-001-001	9355-001-001	9355-001-001	1
10	Locator Post	9467-024-001					2
11	Nut, Locator Post	8640-411-003					2
*	Catch, Top Panel	9086-017-001	9086-017-001	9086-017-001	9086-017-001	9086-017-001	2
12	Lock, Top (w/Key)	8650-012-003					1
12	Lock, Top (w/Key)		8650-012-003	8650-012-003	8650-012-003	8650-012-003	2
*	Gasket Dispensor	9206-416-001	9206-416-001				
*	Hose, Dispensor to tub	9242-450-001	9242-450-001				1
*	Clamp	8654-117-008	8654-117-008				2

Front Mount Detergent Dispenser

Key	Description	T-750	T-900	T-950	T-1200	T-1450	QTY
13	Bolt, #10-32 x 1 1/4"SS				9545-012-026	9545-012-026	6
14	Special Washer, Rubber				8641-242-000	8641-242-000	6
*	Tub Front						1
15	Washer-Flat, 1/4				8641-581-018	8641-581-018	12
16	Nut, #10-32UNF				8640-413-002	8640-413-002	6
17	Spacer Plastic #10x1/2				9538-157-019	9538-157-019	6
18	Soap Dispenser (no lid)				9807-087-001	9807-087-001	1
*	Det. Dispenser Mtg Gasket to Tub frnt				9206-425-001	9206-425-001	1
19	Bracket Soap box mounting				9029-122-002	9029-122-002	1
20	Nut Hex Elasticstop #10-32 SS mtg dispenser				8640-413-006	8640-413-006	6
21	Lid Assembly dispenser				9987-104-001	9987-104-001	1
22	Lid screws #10-32x1/2 SS				9545-012-017	9545-012-017	2
23	Softner siphon tube (plastic)				9574-252-002	9574-252-002	1
*	Flow restrictors				9475-002-003	9475-002-003	AR
24	Washer Dispenser Label Blue				8502-687-001	8502-687-001	1
24	Washer Dispenser Label Black				8502-745-001	8502-745-001	1
*	Kit-Soap Dish upgrade (3 port to 2 Port)				9732-290-001	9732-290-001	*
*	Front Soap Dish Removal Kit				9732-353-003	9732-353-004	*

Rear View Access Part # by Model

Key	Description	T-750	T-900	T-950	T-1200	T-1450	QTY
1	Drive Motor, 3 Phase (Inverter duty)	9376-298-001	9376-308-001	9376-298-001	9376-298-001	9376-328-001	1
2	Rod, Motor Mtg	9497-222-004	9497-222-004	9497-222-004	9497-222-004	9497-222-004	1
*	Collar, Shaft (w/set screws) (old)	9076-052-002	9076-052-002		9076-052-002	9076-052-002	2
*	Motor Bushing (plastic)	9053-074-002	9053-074-002	9053-074-002	9053-074-002	9053-074-002	1
3	New motor bushing support	9053-082-001	9053-082-001	9053-082-001	9053-082-001	9053-082-001	2
4	Clamp for motor bushing	8654-117-019	8654-117-019	8654-117-019	8654-117-019	8654-117-019	2
5	Pulley, Motor	9453-179-001	9453-175-002	9453-175-002	9453-175-002	9453-175-002	1
*	Split TaperBushing (motor pulley)	9053-077-001	9053-077-001	9053-077-001	9053-077-001	9053-077-001	1
*	Screw taper bushing 1/4-20x1	9545-018-024	9545-018-024	9545-018-024	9545-018-024	9545-018-024	3
6	Bolt, Eye (1/4"-20x1/2")	9545-055-001	9545-055-001	9545-055-001	9545-055-001	9545-055-001	1
*	Nut, 1/4 Elastic Stop	8640-414-003	8640-414-003	8640-414-003	8640-414-003	8640-414-003	1
*	Link (open end)	9341-046-001	9341-046-001	9341-046-001	9341-046-001		1
7	Chain (Spring Tension)	9099-012-003	9099-012-003	9099-012-003	9099-012-004		1
8	Spring, Belt Tension	9534-151-000	9534-151-000	9534-151-000	9534-151-000	9534-151-000	1
*	Bracket Belt Tension					9029-206-002	1
*	Lock Washer, Exttooth, 5/16					8641-582-009	
9	Pulley, Driven	9453-179-001	9453-176-006	9453-176-006	9453-176-006	9453-176-006	1
*	Tolerance Ring	9487-234-004					1
*	Screw, 5/8"-11 x 2"	9545-060-004					1
*	Washer-Flat, 5/8"	8641-582-032					1
*	Washer-Flat, 5/8"	8641-582-018					1
10	Bolt, 3/8"-16 x 2"		9545-029-011	9545-029-011	9545-029-011	9545-029-011	3
11	Washer, 3/8"		8641-582-003	8641-582-003	8641-582-003	8641-582-003	3
*	Bushing Taperlock (Driven)		9053-078-002	9053-078-002	9053-078-002	9053-078-002	1
12	Washer-Flat .675x2-1/2x1/4	8641-581-043	8641-581-043	8641-581-043	8641-581-043		1
13	Lockwasher-Exttooth, 5/8	8641-582-018	8641-582-018	8641-582-018	8641-582-018		1
14	Bolt, 5/8-11x1 1/2	9545-060-001	9545-060-001	9545-060-001	9545-060-001		1
12	Washer-Flat, .781x2-1/2x1/4					8641-581-044	1
13	Lockwasher-Exttooth, 3/4					8641-582-020	1
14	Bolt, 3/4-10-1 1/2					9545-057-004	1
15	Drive Belt		9040-079-002	9040-079-002	9040-079-003	9040-079-006	1
15	Drive Belt	9040-076-008					2
*	Panel Assy., Back Before Serial #535659	9989-455-001	9989-455-001		9545-766-001		1
*	Panel Assy., Back After Serial #535659		9989-526-001	9989-526-001			1
*	Panel Assy., Back, Upper					9454-873-001	1
*	Panel Assy., Back, Lower					9454-873-002	1
*	Screw Panel Mtg.#10Bx1/2"	9545-008-026			9545-008-026		
*	Screw Panel Mtg.#10Bx1/2"		9545-008-026	9545-008-026			
*	Screw Panel Mtg.#10Bx1/2"					9545-008-026	15
*	Nut, Spring	8640-399-008	8640-399-008	8640-399-008	8640-399-008	8640-399-008	AR
*	Screw, To Base-1/4" x 3/4"	9545-030-002	9545-030-002	9545-030-002	9545-030-002	9545-030-002	3

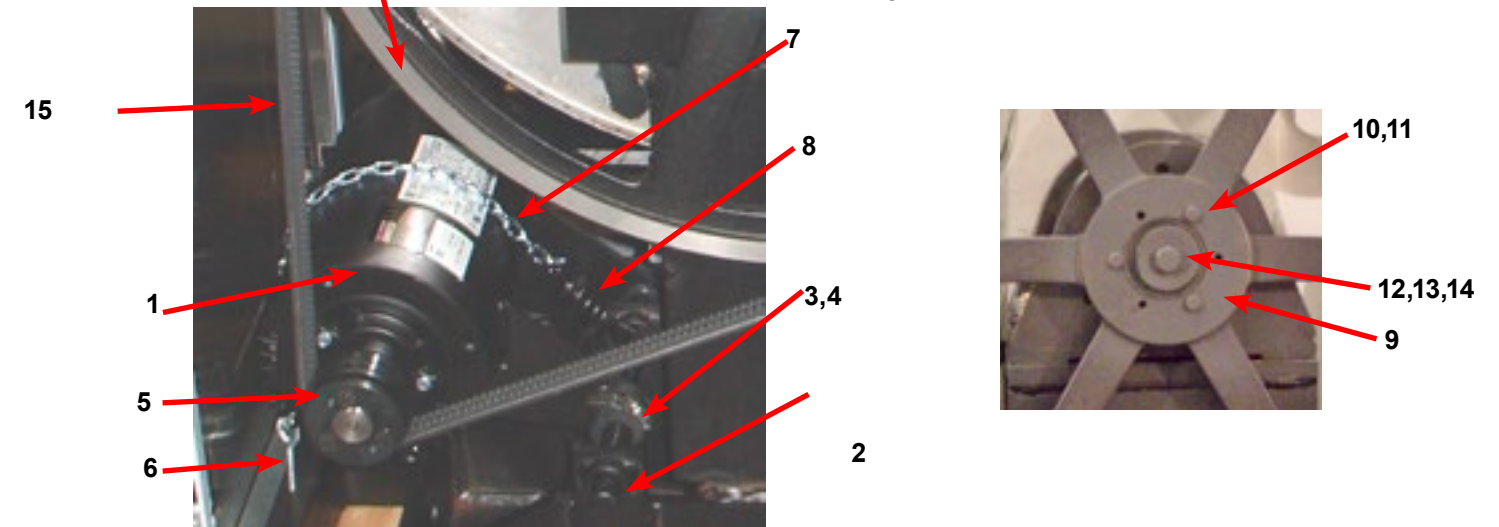
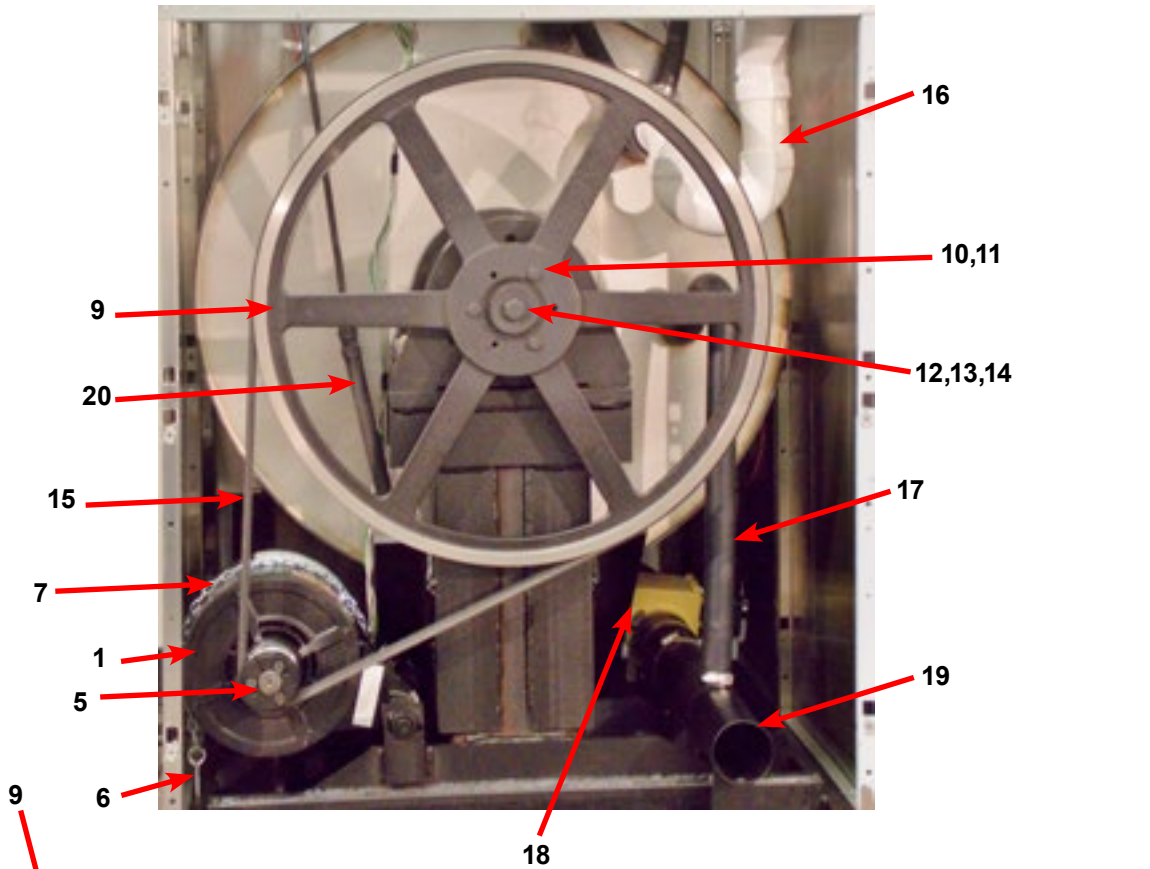

Key	Description	T-750	T-900	T-950	T-1200	T-1450	QTY
16	Injection- tube assy	9883-005-001	9883-005-001	9883-005-001	9883-005-001	9883-011-001	1
16	Injection Tube Assy (After 7/2011)		9883-012-001				
*	Inlet Cap		0935-135-001	0935-135-001			
*	Hose, Injection Tube to Tub	9242-461-001	9242-461-001	9242-461-001	9242-461-001	9242-461-001	1
*	Clamp, Injection Hose	8654-117-014	8654-117-014	8654-117-014	8654-117-014	8654-117-014	2
17	Hose-Overflow	9242-449-003	9242-449-003	9242-449-003	9242-449-003	9242-449-005	1
*	Clamp Hose Over Flow	8654-117-008	8654-117-008	8654-117-008	8654-117-008	8654-117-008	2
18	Drain Valve	9379-187-004	9379-187-004	9379-187-004	9379-187-004	9379-187-004	1
*	Hose, Drain Valve to Tube	9242-457-001	9242-457-001	9242-457-001	9242-457-001	9242-457-001	1
*	Clamp	8654-117-014	8654-117-014	8654-117-014	8654-117-014	8654-117-014	2
19	Drain Tube	9915-124-002	9915-120-004	9915-120-004	9915-126-002	9915-129-002	1

Rear View Access Part # by Model Continued

Key	Description	T-750	T-900	T-950	T-1200	T-1450	QTY
1	Channel, Rear	9081-148-001	9081-152-001	9081-152-002	9081-140-001	9081-153-001	1
2	Screw #10Bx1/2	9545-008-026	9545-008-026	9545-008-026	9545-008-026	9545-008-026	4
*	Nut, Spring	8640-399-008	8640-399-008	8640-399-008	8640-399-008	8640-399-008	4
3	Plate-Cover, Water Valves		9452-794-001				1
4	Screw, 10Bx1/2		9545-008-026				2
5	Plug, 7/8"	9456-041-006	9456-041-006	9456-041-006	9456-041-006	9456-041-006	1
6	Bushing, 7/8"	9053-067-002	9053-067-002	9053-067-002	9053-067-002	9053-067-002	1
7	Braacket-Terminal Block Assy	9029-076-001	9029-076-001	9029-076-001	9029-076-001	9029-076-001	1
8	Screw, 10Bx1/2	9545-008-026	9545-008-026	9545-008-026	9545-008-026	9545-008-026	4
9	Strip-Terminal marker, Power	9558-025-001	9558-025-001	9558-025-001	9558-025-001	9558-025-001	1
10	Terminal Block-Power	9897-033-002	9897-033-002	9897-033-002	9897-033-002	9897-033-002	1
*	Screw-6ABx3/4	9545-031-010	9545-031-010	9545-031-010	9545-031-010	9545-031-010	2
*	Harness-Power Terminal Block	9627-747-003	9627-747-003	9627-747-003	9627-747-003	9627-747-003	1
11	Termminal Lug, Solderless	8652-134-001	8652-134-001	8652-134-001	8652-134-001	8652-134-001	1
*	Lockwasher-Exttooth, #10	8641-582-006	8641-582-006	8641-582-006	8641-582-006	8641-582-006	1
*	Screw-10-32ttX1x1/2Grn	9545-008-027	9545-008-027	9545-008-027	9545-008-027	9545-008-027	2
12	Strip-Terminal Marking, Injector	9558-028-001	9558-028-001	9558-028-001	9558-028-001	9558-028-001	1
13	Terminal Block-Injector	9897-032-002	9897-032-002	9897-032-002	9897-032-002	9897-032-002	1
*	Screw-4Bx5/8ss	9545-053-002	9545-053-002	9545-053-002	9545-053-002	9545-053-002	2
*	Harness-Injection	9627-799-001	9627-799-001	9627-799-001	9627-799-003	9627-799-002	1
14	Label-Warning	8502-639-001	8502-639-001	8502-639-001	8502-639-001	8502-639-001	1
15	Bushing-Insulated, 3/4"	9053-067-001	9053-067-001	9053-067-001	9053-067-001	9053-067-001	1
16	Bushing-Insulated, 1"	9053-067-004	9053-067-004	9053-067-004	9053-067-004	9053-067-004	1
17	Cover, Terminal Block	9074-267-001	9074-267-001	9074-267-001	9074-267-001	9074-267-001	1
18	Screw #10Bx1/2	9545-008-026	9545-008-026	9545-008-026	9545-008-026	9545-008-026	1
19	Fuse Holder Assy	9200-001-002	9200-001-002	9200-001-002	9200-001-002	9200-001-002	1
*	Fuse, 1.5Amp	8636-018-001	8636-018-001	8636-018-001			
*	Fuse, 2.5Amp				8636-018-004	8636-018-004	
20	Label-Fuse, 1.5Amp	8502-716-001	8502-716-001	8502-716-001			
20	Label-Fuse, 1.5Amp				8502-716-002	8502-716-002	
21	Bracket assembly (drive mount)	9029-157-001	9029-157-001	9029-212-001	9029-150-001	9029-216-001	1
22	Screw, #10Bx1/2"	9545-008-026	9545-008-026	9545-008-026	9545-008-026	9545-008-026	6
23	Nut, Spring	8640-399-001	8640-399-001	8640-399-001	8640-399-001	8640-399-001	6
24	Gromet, 3/16" I.D.	9209-037-002	9209-037-002	9209-037-002	9209-037-002	9209-037-002	6
25	VFD Delta "S" drive 208-240 volt	9732-345-012	9732-345-022		9375-018-002		1
25	VFD Delta "E" drive 208-240 volt			9375-028-003		9375-029-003	1
*	Cable, Data	9806-015-001	9806-015-001	9806-015-001	9806-015-003	9806-015-003	1
*	Clamp, Cable	8654-125-005	8654-125-005	8654-125-005	8654-125-005	8654-125-005	1
*	Screw, 8Bx1/4"	9545-045-001	9545-045-001	9545-045-001	9545-045-001	9545-045-001	1
*	Screw-10-32ttX1x1/2Grn	9545-008-027	9545-008-027	9545-008-027	9545-008-027	9545-008-027	2
*	Lockwasher-Exttooth, #10	8641-582-006	8641-582-006	8641-582-006	8641-582-006	8641-582-006	2
26	Cover, VFD, Before Serial #935659	9074-278-001	9074-278-001		9074-278-001		1
26	Cover, VFD, After Serial #935659		9074-342-001	9074-342-001	9074-299-001	9074-299-001	1
27	Screw #10Bx1/2	9545-008-026	9545-008-026	9545-008-026	9545-008-026	9545-008-026	1
28	Valve-Water, Duel Coil	9379-183-003	9379-183-003	9379-183-003	9379-183-003	9379-183-003	2
29	Screw #10Bx1/2	9545-008-026	9545-008-026	9545-008-026	9545-008-026	9545-008-026	4
30	Water-Valve, Single Coil			9379-194-001	9379-194-001	9379-194-001	2
31	Screw-Phillips, 4mx0.7x8mm			9545-064-001	9545-064-001	9545-064-001	4

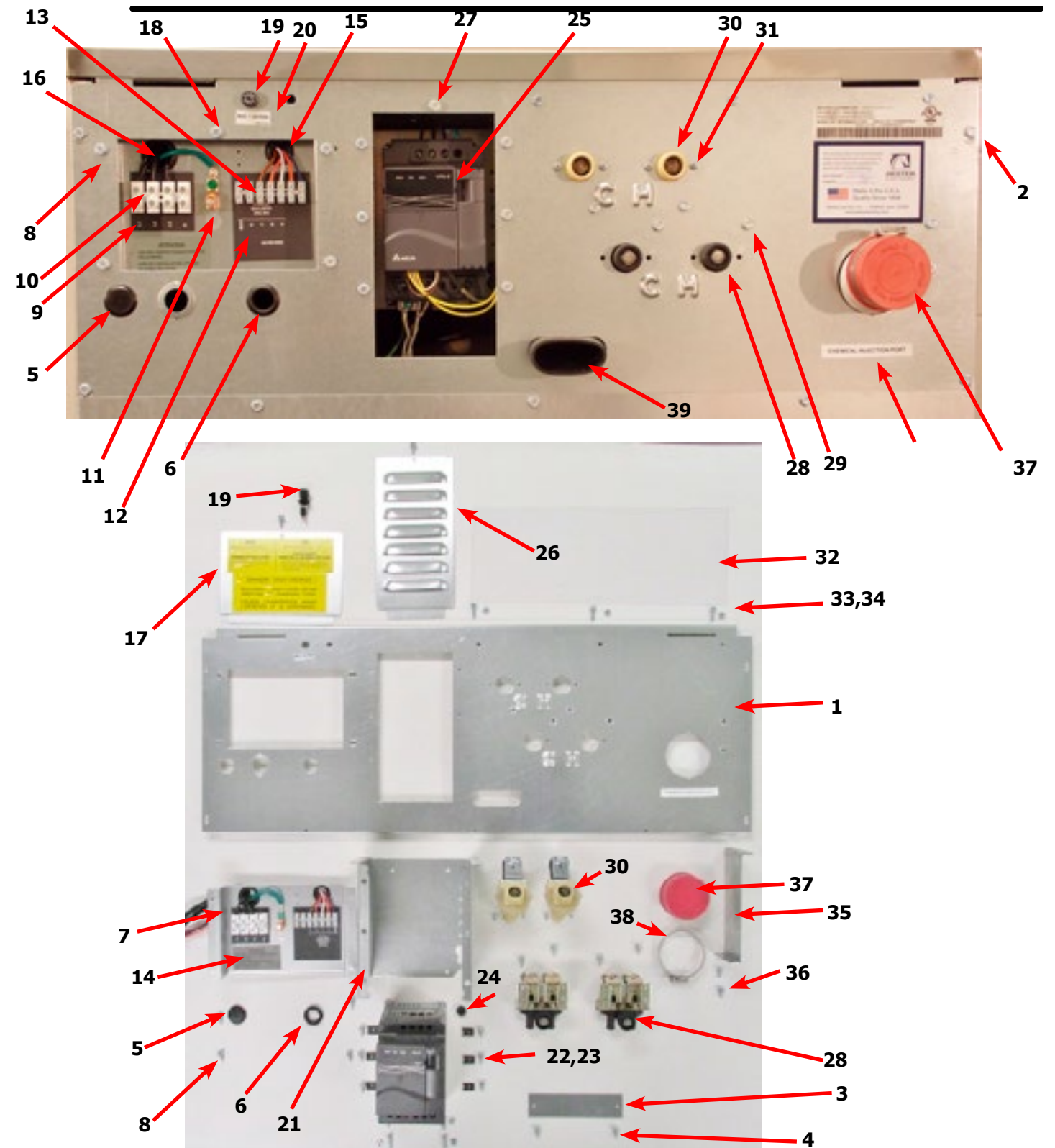

Key	Description	T-750	T-900	T-950	T-1200	T-1450	QTY
32	Shield, Water Valves	9550-186-001					1
33	Screw, 10-32x3/4"	9545-012-006					2
34	Nut, #10-32	8640-413-004					2
35	Bracket-Vacume Breaker	9029-069-001	9029-069-001	9029-069-001	9029-069-001	9029-069-002	1
36	Screw, 10Bx1/2	9545-008-026	9545-008-026	9545-008-026	9545-008-026	9545-008-026	2
37	Cap-Injector Assy	0935-127-001	0935-127-001	0935-127-001	0935-127-001	0935-127-001	1
38	Clamp	8654-117-014	8654-117-014	8654-117-014	8654-117-014	8654-117-014	1
39	Hose-Suds Overflow	9242-463-004	9242-463-004	9242-463-004	9242-463-004	9242-463-006	

Cylinder, Seals & Bearings Part # by Model

Key	Description	T-750	T-900	T-950	T-1200	T-1450	QTY
1	Bearings and Seal Kit	9732-219-007	9732-219-007	9732-219-007	9732-219-007	9732-219-009	1
1	Housing, Bearing- Assembly (items #2-#6)	9803-187-001	9803-187-001	9803-187-001	9803-187-001	9803-209-001	1
2	Housing, Bearing	9241-181-004	9241-181-004	9241-181-004	9241-181-004	9241-195-003	1
3	Bearing, Front (LARGE)	9036-159-006	9036-159-006	9036-159-006	9036-159-006	9036-162-002	1
4	Bearing, Rear (SMALL)	9036-159-005	9036-159-005	9036-159-005	9036-159-005	9036-162-001	1
5	Spacer, Bearing	9538-170-001	9538-170-001	9538-170-001	9538-170-001	9538-185-001	1
6	Ring, Bearing Retainer	9487-238-004	9487-238-004	9487-238-004	9487-238-004	9487-238-004	1
7	Tub Assembly	9930-148-001	9930-157-001	9930-157-001	9930-150-001	9930-155-001	1
8	Seal, Small V85A	9532-140-007	9532-140-007	9532-140-007	9532-140-007		1
8	Seal, Small V95A					9532-140-012	1
9	Seal, Large V140A	9532-140-008	9532-140-008	9532-140-008	9532-140-008	9532-140-008	1
10	Ring, Seal Mounting	9487-261-004	9950-052-001	9950-052-001	9950-052-001	9950-062-001	1
11	Tub Back Mating Ring	9487-266-001	9950-054-004	9950-054-004	9950-054-004	9487-276-001?	1
11G	Mating Ring Guard Shield	9487-266-001	9487-266-001	9487-266-001	9487-266-001	9487-261-005	1
12	Bolt, Tub End of Bearing Housing (7/16-14x1), Bolt from inside Tub	9545-059-004	9545-059-004	9545-059-004	9545-059-004	9545-059-004	6
13	Washer, Flat	8641-581-034	8641-581-034	8641-581-034	8641-581-034	8641-581-034	6
14	Screw-Hex Cap, 3/4"-10 x 3" (Bearing Housing to Frame)	9545-057-002	9545-057-002	9545-057-002	9545-057-002		6
14	Screw-Hex Cap, 7/8"-10 x 3" (Bearing Housing to Frame)					9545-066-001	6
15	Washers Spherical 3/4 (Male half) (Bearing Housing to Frame)	8641-588-001		8641-588-001	8641-588-001		6
15	Washers Spherical 7/8 (Male half) (Bearing Housing to Frame)					8641-588-003	6
16	Washers Spherical 3/4 (Female half) (Bearing Housing to Frame)	8641-588-002		8641-588-002	8641-588-002		6
16	Washers Spherical 7/8 (Female half) (Bearing Housing to Frame)					8641-588-004	6
15	Washer, Flat		8641-581-033				6
16	Lock Washer-Extrenal Tooth, 3/4" (Bearing Housing to Frame)		8641-582-020				6
17	Nut 3/4"-10 (Bearing Housing to Frame)	8640-418-003	8640-418-003	8640-418-003	8640-418-003		6
17	Nut 7/8"-9 (Bearing Housing to Frame)					8640-437-001	6
18	Pulley, Driven	9453-173-002	9453-176-006	9453-176-006	9453-176-006	9453-176-006	1
*	Tolerance Ring	9487-234-004					1
*	Screw, 5/8"-11 x 2"	9545-060-004					1
*	Washer-Flat, 5/8"	8641-581-032					1
*	Washer-Flat, 5/8"	8641-582-018					1
19	Bolt, 3/8"-16 x 2"		9545-029-011	9545-029-011	9545-029-011	9545-029-011	3
20	Washer, 3/8"		8641-582-003	8641-582-003	8641-582-003	8641-582-003	3
21	Bushing Taperlock (Driven & Large)		9053-078-002	9053-078-002	9053-078-002	9053-078-002	1
22	Washer-Flat .675x2-1/2x1/4		8641-581-043	8641-581-043	8641-581-043		1
23	Lockwasher-Exttooth, 5/8		8641-582-018	8641-582-018	8641-582-018		1
24	Bolt, 5/8-11x1 1/2		9545-060-001	9545-060-001	9545-060-001		1
22	Washer-Flat, .781x2-1/2x1/4					8641-581-044	1
23	Lockwasher-Exttooth, 3/4					8641-582-020	1
24	Bolt, 3/4-10-1 1/2					9545-057-004	1
25	Tub & Cylinder Assy Before Serial #535659	9869-025-001	9869-023-003		9869-022-001		1
25	Tub & Cylinder Assy After Serial #535659		9869-027-003	9869-027-003		9869-026-002	1

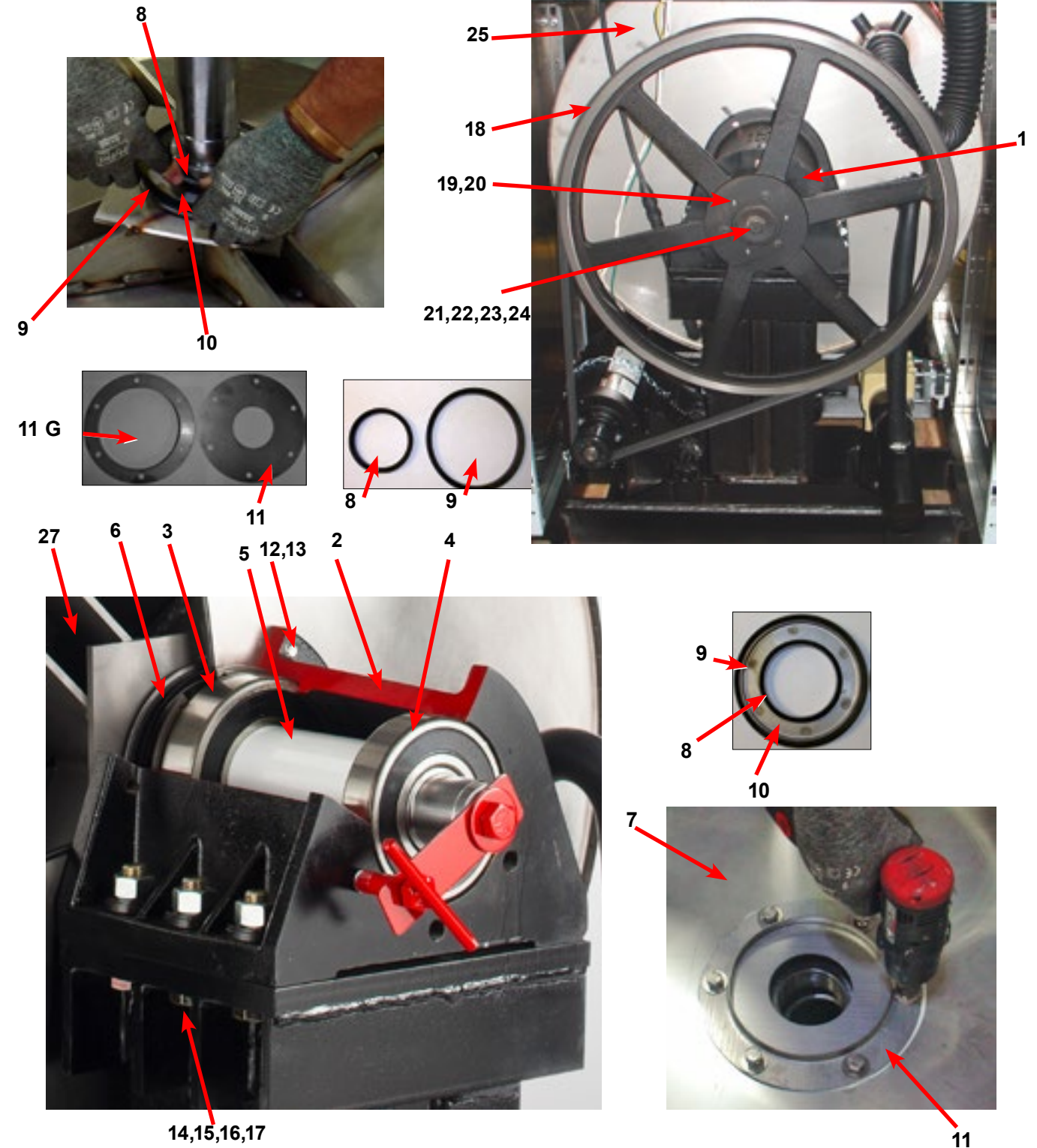

Key	Description	T750	T-900	T950	T-1200	T1450	QTY
27	Cylinder Assy	9848-136-002	9848-136-001	9848-136-001	9848-137-002	9848-141-001	
*	Tub Front Before Serial #535659	9974-011-001	9974-011-001		9974-011-001		1
*	Tub Front After Serial #535659		9974-011-001	9974-011-001		9974-012-001	1
*	Gasket, Tub Front	9206-421-002	9206-421-002	9206-421-002	9206-421-002	9206-421-???	1
*	Ring Assy, Tub Mtg-Front Clamp	9950-055-001	9950-055-001	9950-055-001	9950-055-001	9950-061-001	1
*	Bolt, Top Front Ring 3/8"-16 x 3"	9545-029-009	9545-029-009	9545-029-009	9545-029-009	9545-029-009	1
*	Nut WCAD 3/8"-16	8640-415-001	8640-415-001	8640-415-001	8640-415-001	8640-415-001	1

Door Lock Assembly (All Models)

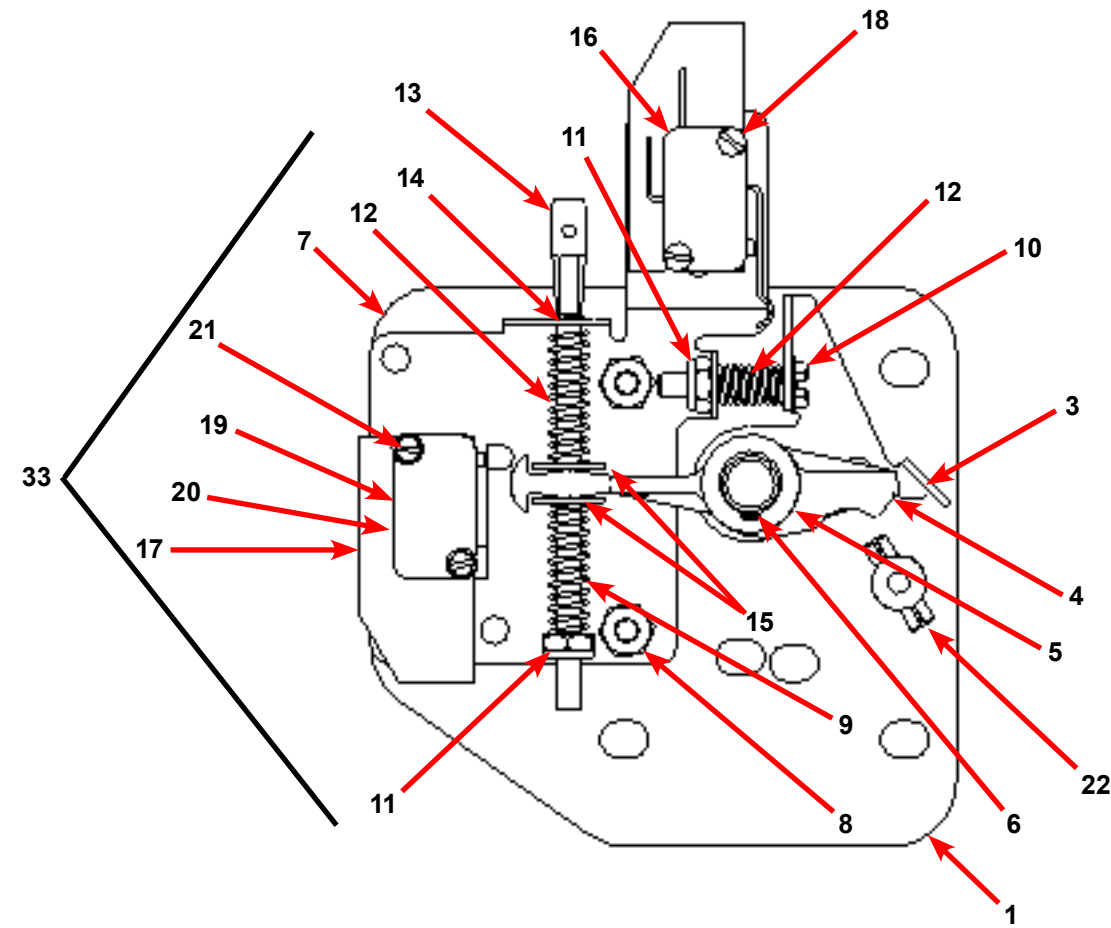

Key	Description	All Models	QTY
33	Lock Assy, Complete (#1-22) (includes #1 thru #22)	9885-024-001	1
1	Plate Assy, Door Lock	9982-346-001	1
2	Washer, Flat (SS or Brass)	8641-581-030	1
3	Actuator, Latching Switch	9008-005-001	1
4	Pawl, Locking	9732-346-002	1
5	Washer, Spring	8641-569-003	1
6	Ring, Retaining	9487-200-004	1
7	Bracket Switch	9029-163-001	1
8	Nut, Hex 10-32 UNF	8640-413-002	2
9	Spring, Actuating	9534-364-002	1
10	Screw, Hx. 10-32 x 1"	9545-012-020	1
11	Nut, Elastic Stop 10-32	8640-413-004	2
12	Spring, Return	9534-364-001	2
13	Pin, Guide	9451-193-001	1

Key	Description	All Models	QTY
14	Ring, Retaining	9487-200-005	1
15	Washer	8641-581-031	1
16	Switch, Latching Sensing	9539-461-008	1
17	Shield, Switch	9550-169-003	3
18	Screw 4-40 x 5/8"	9545-020-001	2
18	Nut, Twin 4-40	8640-401-001	1
19	Switch, Locking Sensing	9539-461-007	2
20	Actuator, Switch Locking	9008-006-003	1
21	Screw 4-40 x 1 1/8"	9545-020-003	2
21	Nut, Twin 4-40	8640-401-001	1
*	Spacer Sensor	9538-182-001	*
22	Pin, Dowel (for door cam)	9451-181-004	1
*	Shim, Door Lock, Thin	9552-037-001	AR
*	Screw, Lock mtg 1/4"-20 x 3/4"	9545-018-014	3
*	Lockwasher 1/4" Ext tooth	8641-582-007	3
*	Door Stud Pin, 3/16" x 3/4"	9451-181-004	1

Gear Motor Door Lock Assembly

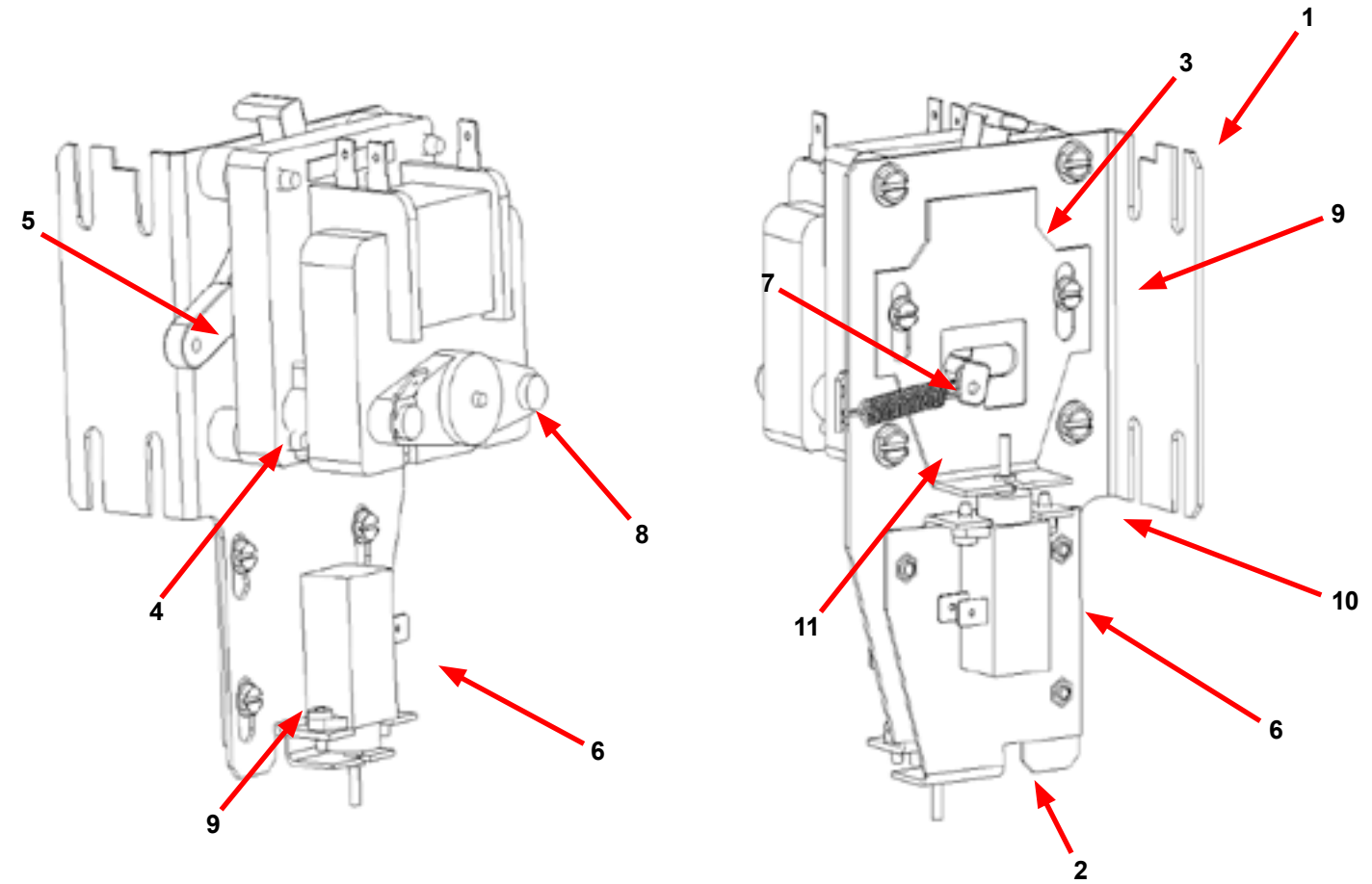

Key	Description	T-750	T-900	T-950	T-1200	T-1450	QTY
*	Actuator Assembly (Includes 1-10, Rod NOT included)	9892-015-001	9892-015-001	9892-015-001	9892-015-001	9892-015-001	1
11	Screw - hxwshdsl 10-24 - 1.25f, ctd	9545-046-007	9545-046-007	9545-046-007	9545-046-007	9545-046-007	4
10	Cross Recessed PAn Hd Tapping screw	9545-031-011	9545-031-011	9545-031-011	9545-031-011	9545-031-011	4
9	Screw -Hxwshrdslsems, 6-32 x 3/16	9545-044-003	9545-044-003	9545-044-003	9545-044-003	9545-044-003	6
8	Motor & Gear Assembly 120v	9914-137-011	9914-137-011	9914-137-011	9914-137-011	9914-137-011	1
7	Spring - Extension	9534-350-001	9534-350-001	9534-350-001	9534-350-001	9534-350-001	1
6	Thermoactuator - Door Lock Relay 120v	9586-001-001	9586-001-001	9586-001-001	9586-001-001	9586-001-001	2
5	Arm - Door Lock	9001-063-001	9001-063-001	9001-063-001	9001-063-001	9001-063-001	1
4	Spacer, Plastic	9538-157-021	9538-157-021	9538-157-021	9538-157-021	9538-157-021	4
3	Bracket Slide Lock	9029-204-001	9029-204-001	9029-204-001	9029-204-001	9029-204-001	1
2	Bracket Assy, Slide - Unlock	9985-189-001	9985-189-001	9985-189-001	9985-189-001	9985-189-001	1
1	Bracket Assy, Slide Lock Actuator	9985-190-001	9985-190-001	9985-190-001	9985-190-001	9985-190-001	1
*	Rod, Door Lock Before Serial #535659	9497-225-013	9497-225-013				1
*	Rod, Door Lock After Serial #535659		9497-225-015	9497-225-015	9497-225-015	9497-225-016	1

Original Door Lock Solenoid Assembly

Key	Description	T-750	T-900	T-950	T-1200	T-1450	QTY
1	Solenoid Ass'y, Door Locking (includes 23 thru 32)	9922-011-001	9922-011-001		9922-011-001		1
2	Bracket, (Door Locking Solenoid)	9029-073-001	9029-073-001		9029-073-001		1
3	Bracket Ass'y, Solenoid Slide	9985-169-001	9985-169-001		9985-169-001		1
4	Solenoid 120V 60 hz	9536-074-001	9536-074-001		9536-074-001		1
5	Screw, Solenoid Mtg	9545-008-001	9545-008-001		9545-008-001		4
6	Stop, Door Lock Solenoid	9540-033-002	9540-036-001		9540-033-002		1
7	Screw, Shoulder	9545-061-001					1
*	Nut, Keps #6	8640-411-002	8640-411-002		8640-411-002		1
9	Thermoactuator 120 V	9586-001-001	9586-001-001		9586-001-001		2
10	Screw #6 x 5/16"	9545-031-011	9545-031-011		9545-031-011		4
11	Spacer, Plastic	9538-157-004	9538-157-004		9538-157-004		1
12	Spacer, Metal	9538-166-004	9538-166-004		9538-166-004		1
13	Screw, Cross Recessed	9545-010-001	9545-010-001		9545-010-001		1
14	Nut, Keps #8	8640-412-005	8640-412-005		8640-412-005		1
*	Nut, Sol. Brkt. to Control Panel	8640-412-005	8640-412-005		8640-412-005		3
*	Rod, Pull	9497-225-007	9497-225-007		9497-225-009		1

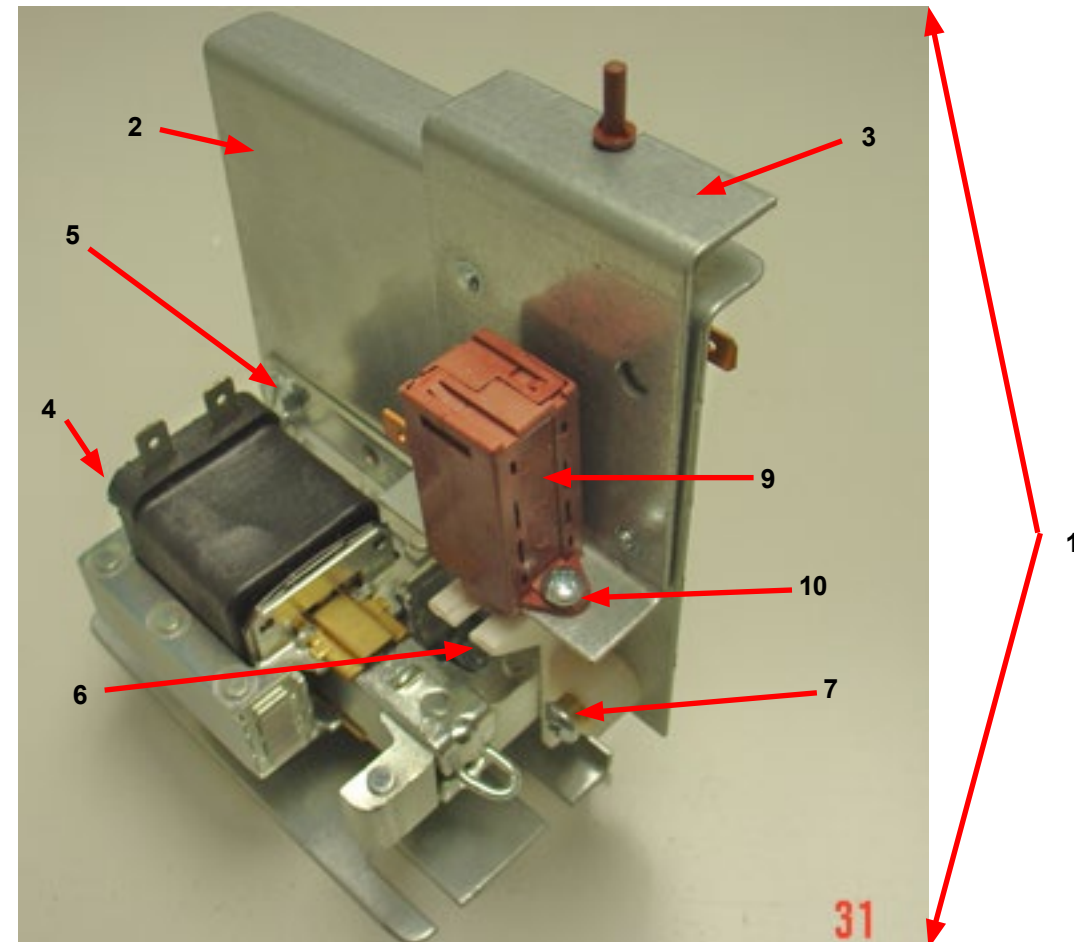

Original Door Lock Solenoid Assembly

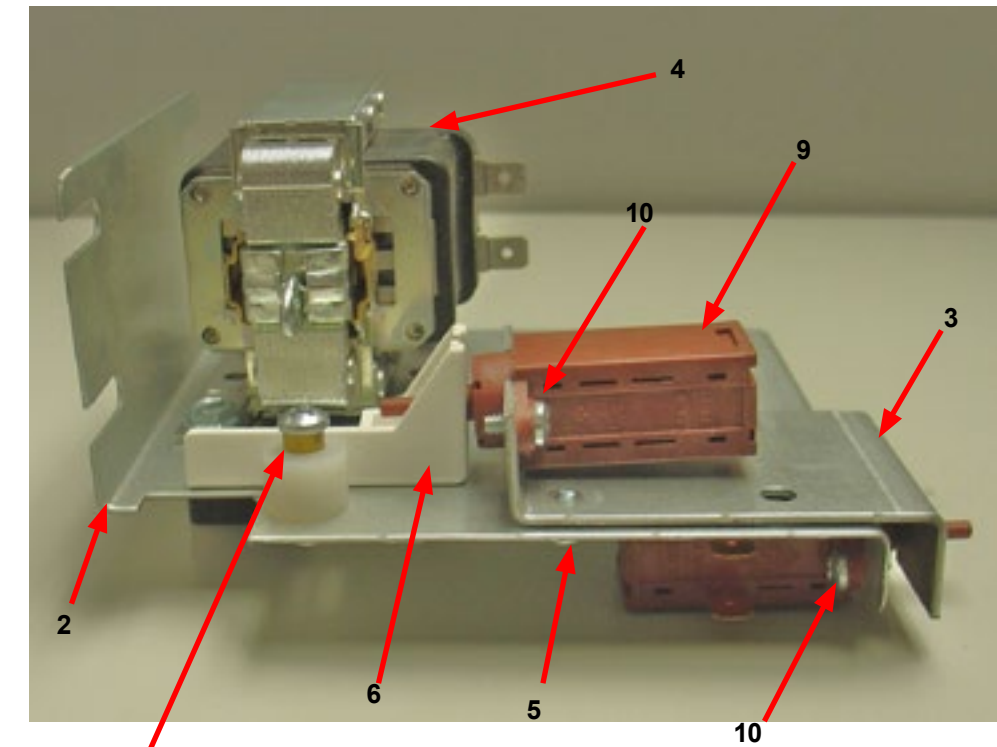

Large Door & Hinge Group (After #514975)

Key	Description	T-750	T-900	T-950	T-1200	T-1450	QTY
1	Door Hinge Assembly (mounts to tub front)	9955-031-001	9955-031-001	9955-031-001	9955-031-001	9955-031-001	1
*	Door Assembly Complete	9960-274-005	9960-274-005	9960-274-005	9960-274-005	9960-274-005	1
2	Door Ring 180 degree large hinge	9487-275-001	9487-275-001	9487-275-001	9487-275-001	9487-275-001	1
3	Door Gasket	9206-431-001	9206-431-001	9206-431-001	9206-431-001	9206-431-001	1
4	Door Glass Window	9635-020-001	9635-020-001	9635-020-001	9635-020-001	9635-020-001	1
*	Red Wire (Door Close Switch)	8220-063-028	8220-063-028	8220-063-028	8220-063-028	8220-063-028	1
	Black Wire (Door Close Switch)	8220-063-029	8220-063-029	8220-063-029	8220-063-029	8220-063-029	1
5	Switch, Door Hinge Close (Plunger)	9539-492-001	9539-492-001	9539-492-001	9539-492-001	9539-492-001	1
6	Top Door Hinge Leaf (No pin)	9845-006-001	9845-006-001	9845-006-001	9845-006-001	9845-006-001	1
7	Bottom Door Hinge Leaf	9845-007-001	9845-007-001	9845-007-001	9845-007-001	9845-007-001	1
8	Thrd Form Screw, Door Mtg 5/16" x 5/8"	9545-056-002	9545-056-002	9545-056-002	9545-056-002	9545-056-002	4
9	Screw, Loading Door Hinge Mtg (5/16" x 9/16" ss)	9545-014-013	9545-014-013	9545-014-013	9545-014-013	9545-014-013	3
10	Bracket Retainer support side panel	9045-085-001	9046-085-001	9046-085-001	9046-085-001	9046-085-001	1
*	Shim Large door	9552-043-001	9552-043-001	9552-043-001	9552-043-001	9552-043-001	1

Key	Description	T750	T-900	T950	T-1200	T1450	QTY
11	Shaft, Door Locking	9537-195-002	9537-195-002	9537-195-002	9537-195-002	9537-195-002	1
12	Cam, Locking	9095-040-002	9095-040-002	9095-040-002	9095-040-002	9095-040-002	1
13	Pin, Groove (1 1/4)	9451-181-005	9451-181-005	9451-181-005	9451-181-005	9451-181-005	1
14	Pin, Groove (3/4)	9451-181-004	9451-181-004	9451-181-004	9451-181-004	9451-181-004	1
15	Spring, Lock Cam	9534-360-002	9534-360-002	9534-360-002	9534-360-002	9534-360-002	1
16	Handle, Door	9244-080-003	9244-080-003	9244-080-003	9244-080-003	9244-080-003	1
17	Pin, Door Handle (groove)	9451-181-006	9451-181-006	9451-181-006	9451-181-006	9451-181-006	1

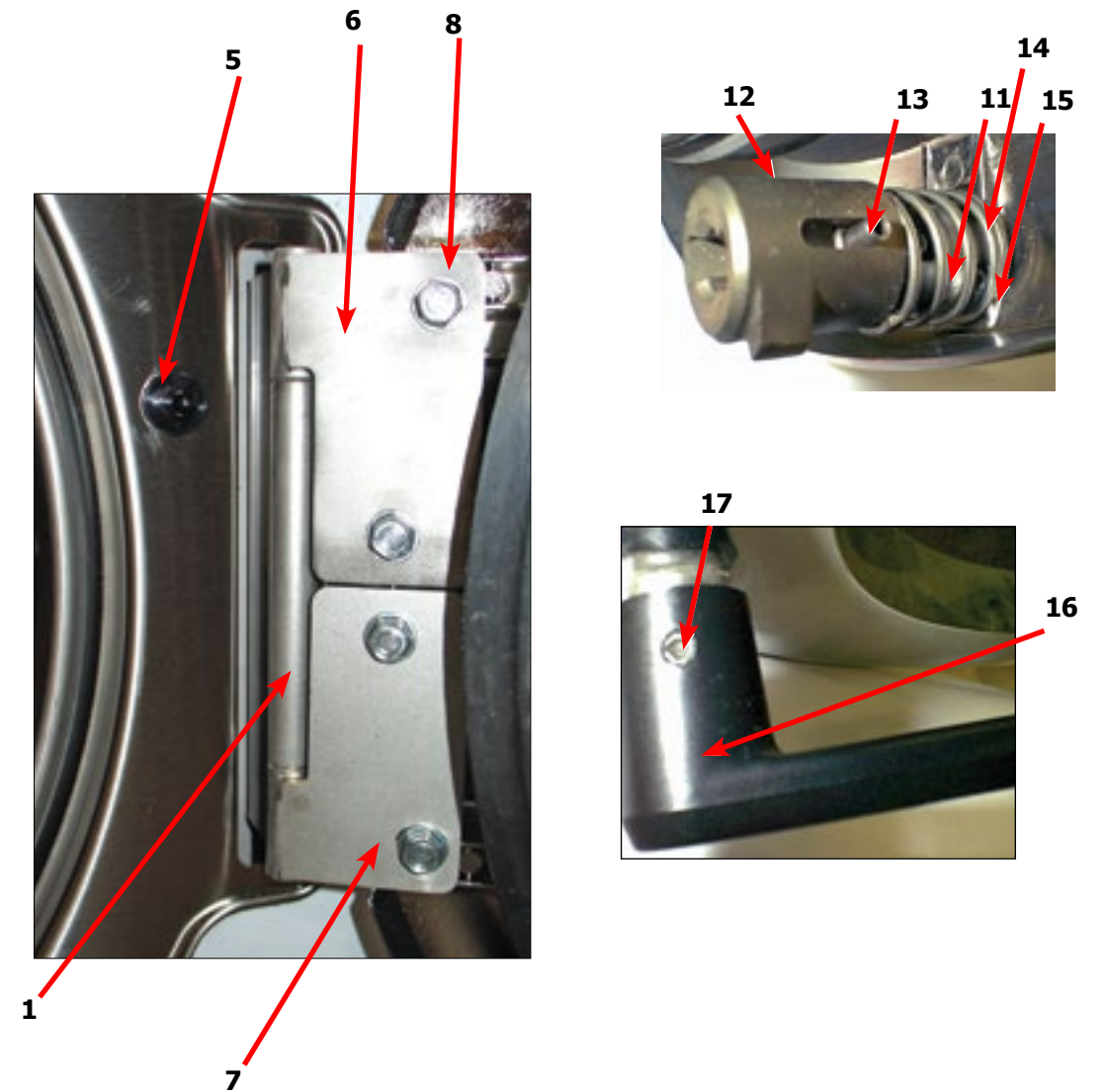
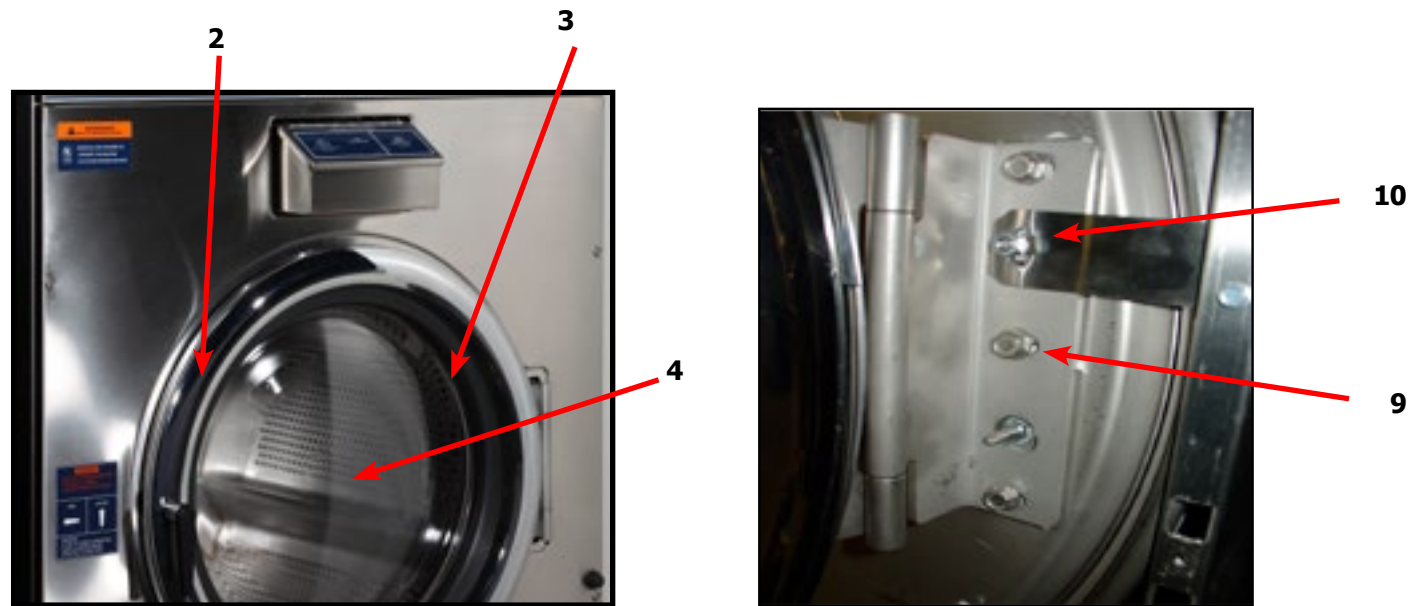

WCVD75 180-Degree Door & Hinge Group

(Before #514975)

Key	Part Number	Description.....	Qty
*	9960-274-004	Loading Door, Complete (includes #1thru #10)	1
1	9487-265-002	Loading Door Ring 180 degree.....	1
2	9206-419-001	Gasket, Loading Door.....	1
3	9635-016-001	Window, Loading Door.....	1
4	9913-134-003	Shaft Assy. Locking (includes #5 thru #8).....	1
5	9537-195-002	Shaft, Door Locking.....	1
6	9095-040-001	Cam, Locking.....	1
7	9451-181-005	Pin, Groove (1 1/4).....	1
8	9451-181-005	Pin, Groove (3/4).....	1
9	9534-360-002	Spring, Lock Cam.....	1
10	9244-080-003	Handle, Door.....	1
17	9451-181-006	Roll Pin, Door Handle (groove).....	1
11	9955-030-001	Hinge Assy, Loading Door (mounts to tub front).....	1
*	9545-014-009	Screw, Hinge Mtg.....	3
*	8641-582-009	Lockwasher.....	3
*	9552-036-001	Shim, Loading Door Hinge, Thin.....	AR
*	9552-036-002	Shim, Loading Door Hinge, Thick.....	AR
12	9845-005-003	Top, Loading Door Leaf Hinge with pin.....	1
13	9845-005-002	Bottom, Loading Door Leaf Hinge.....	1
16	9545-056-002	Screw, Loading Door Hinge Mtg.....	3
15	9950-060-002	Ring, Masking w door switch hole.....	1
*	8640-413-002	Nut.....	4
*	9059-063-002	Band Edge Protector.....	1
*	9801-089-001	Door Closure Switch Assembly.....	1
D1	9041-087-001	Switch Box.....	1
*	9053-067-003	Bushing Insulating.....	1
D3	9539-461-007	Switch, Micro.....	1
D2	9550-159-001	Switch, Shield.....	1
D4	8640-401-001	Nut Special Twin #4-40.....	1
D8	9545-020-001	Screw 4-40x5/8.....	2
D7	9008-004-001	Door Switch Actuator.....	1

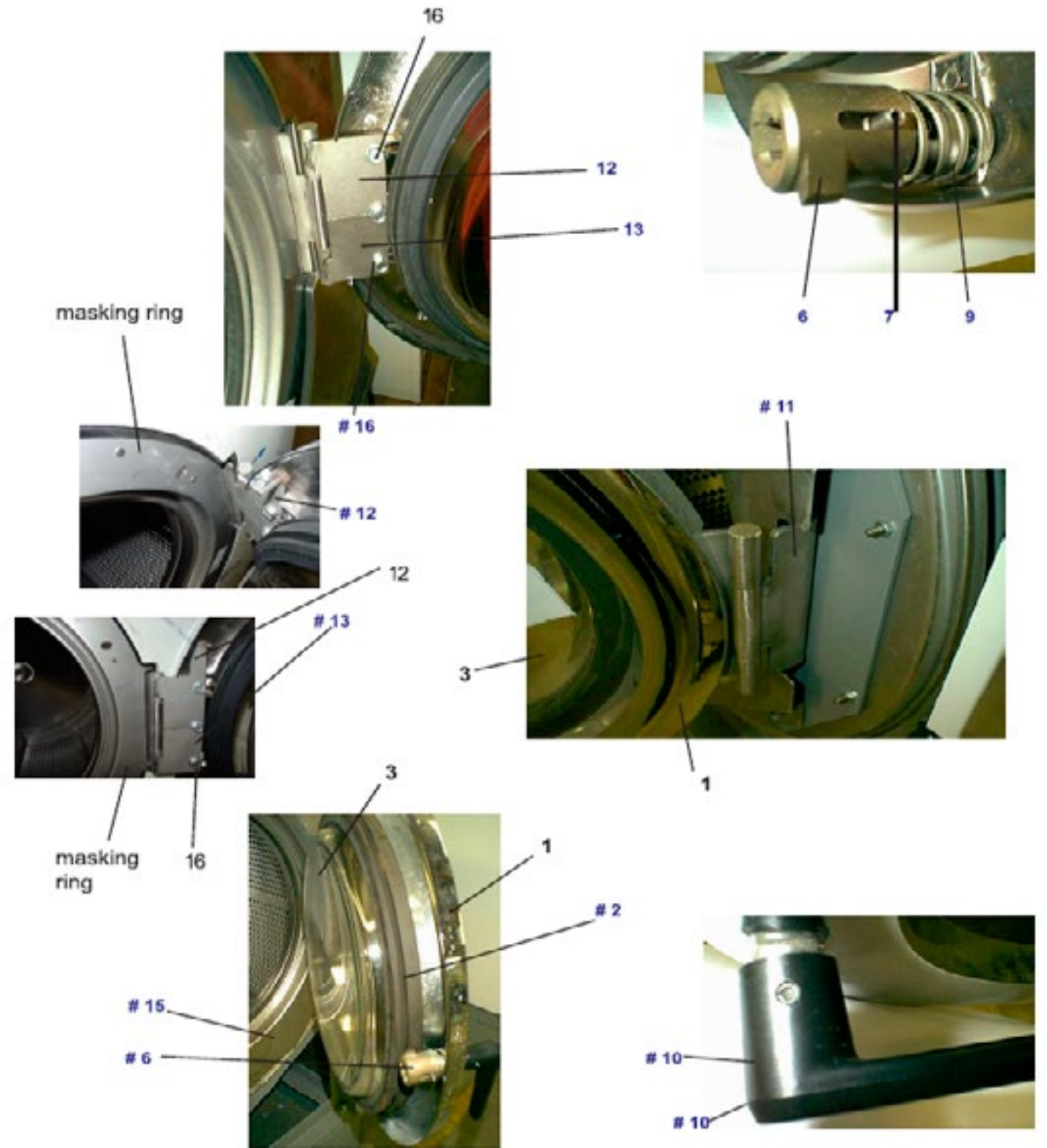
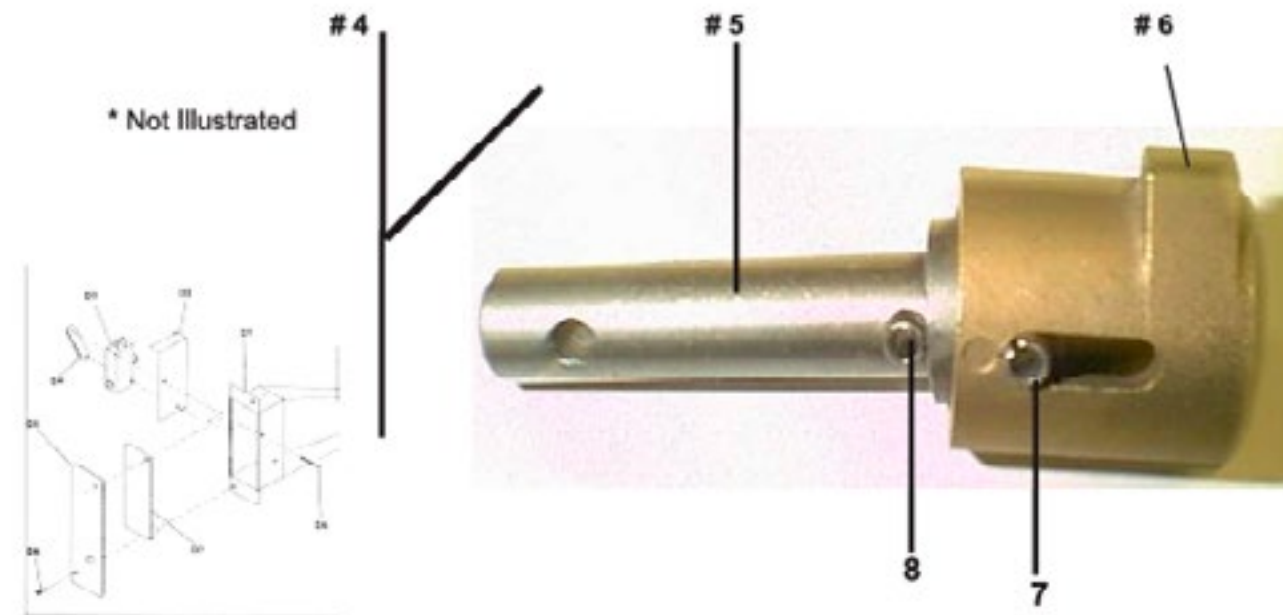

Door & Hinge Group

(Before #514975)

Key	Part Number	Description.....Qty
*	9960-274-002	Loading Door, Complete (includes #1thru #10)1
1	9487-265-001	Loading Door Ring.....1
2	9206-419-001	Gasket, Loading Door.....1
3	9635-016-001	Window, Loading Door.....1
4	9913-134-003	Shaft Assy. Locking (includes #5 thru #8).....1
*	9537-195-002	Shaft, Door Locking.....1
5	9095-040-001	Cam, Locking.....1
6	9451-181-005	Pin, Groove (1 1/4).....1
7	9451-181-005	Pin, Groove (3/4).....1
8	9534-360-002	Spring, Lock Cam.....1
9	9244-080-003	Handle, Door.....1
*	9451-181-006	Roll Pin, Door Handle (groove).....1
10	9955-029-002	Hinge Assy, Loading Door (mounts to tub front).....1
*	9545-014-009	Screw, Hinge Mtg.....3
*	8641-582-009	Lockwasher.....3
*	9552-036-001	Shim, Loading Door Hinge, Thin.....AR
12	9938-040-002	Hinge Clamp assembly w/ pin.....1
13	9545-056-003	Screw, Loading Door Hinge Mtg.....3
14	9950-060-001	Ring, Masking w door switch hole.....1
*	8640-413-002	Nut.....4
*	9059-063-002	Band Edge Protector.....1
*	9801-089-001	Door Closure Switch Assembly.....1
D1	9041-087-001	Switch Box.....1
*	9053-067-002	Bushing Insulating.....1
D3	9539-461-007	Switch, Micro.....1
D2	9550-159-001	Switch, Shield.....1
D4	8640-401-001	Nut Special Twin #4-40.....1
D8	9545-020-001	Screw 4-40x5/8.....2
D7	9008-004-001	Door Switch Actuator.....1

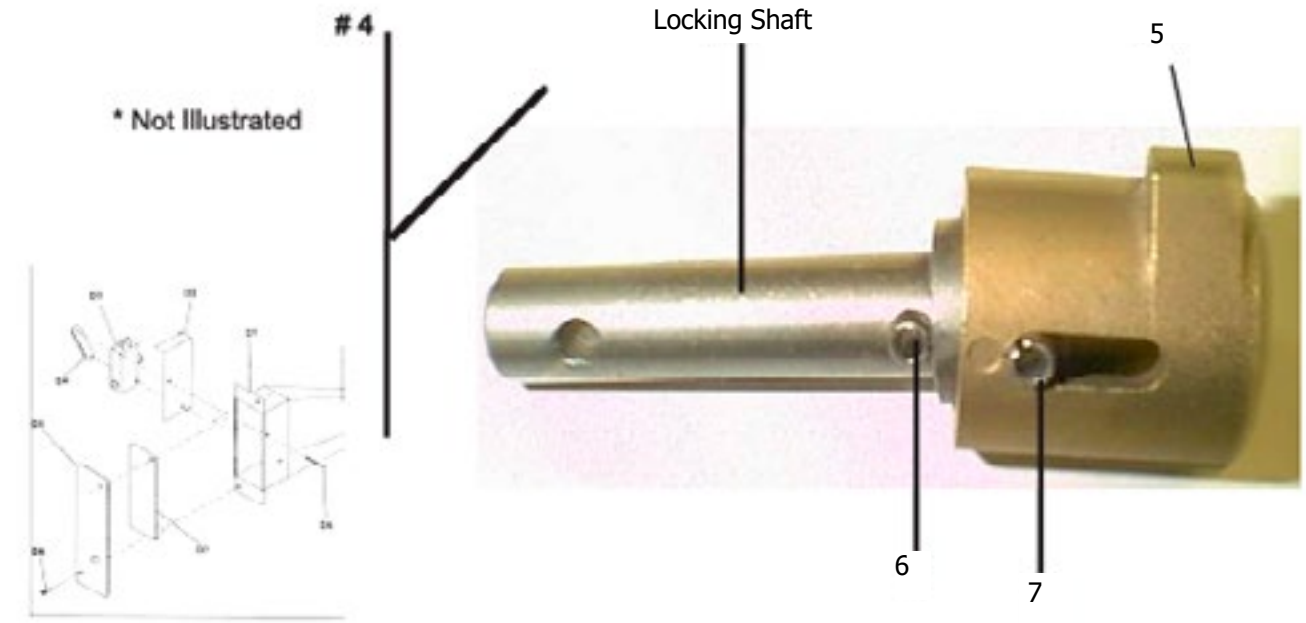
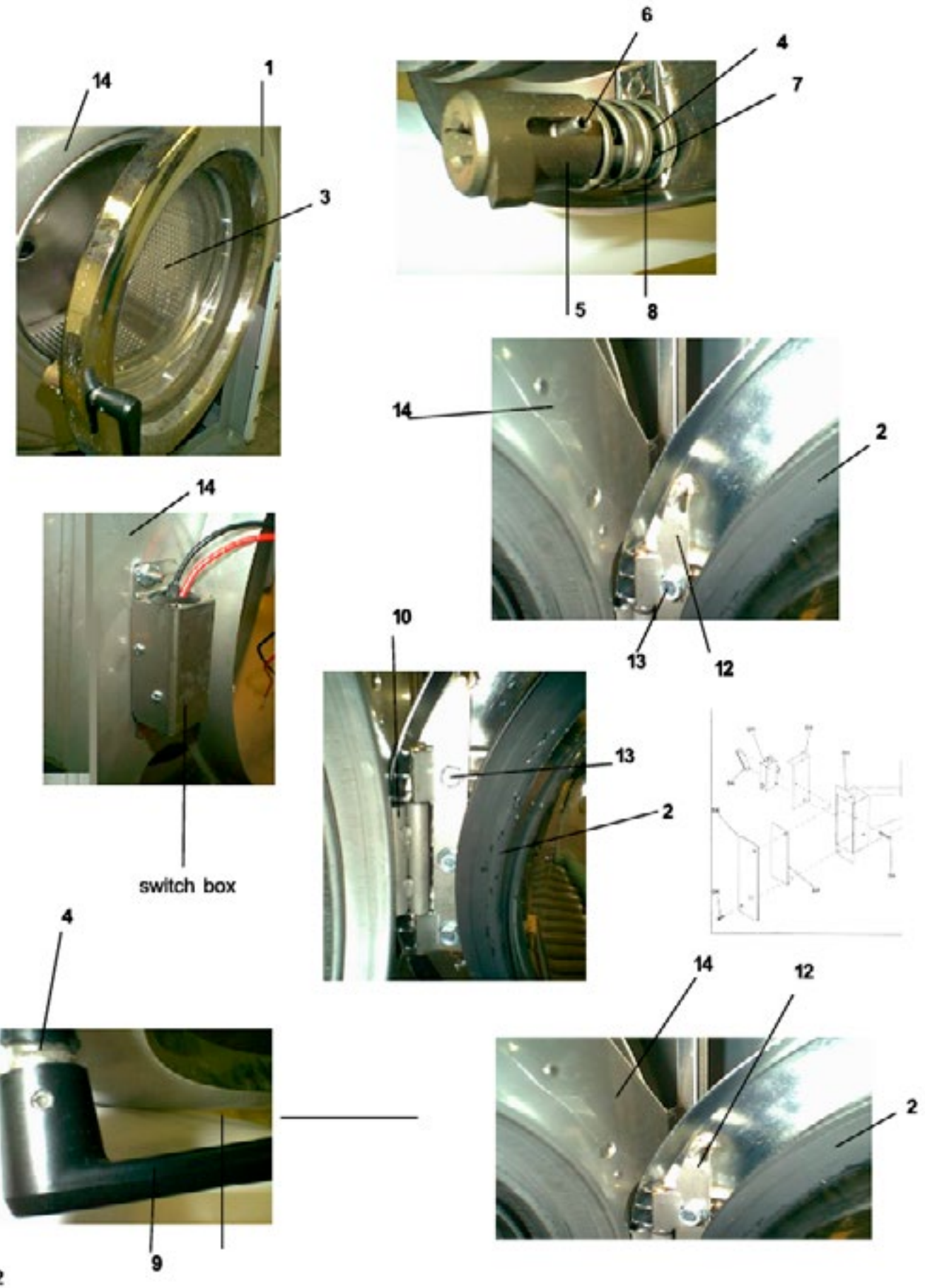

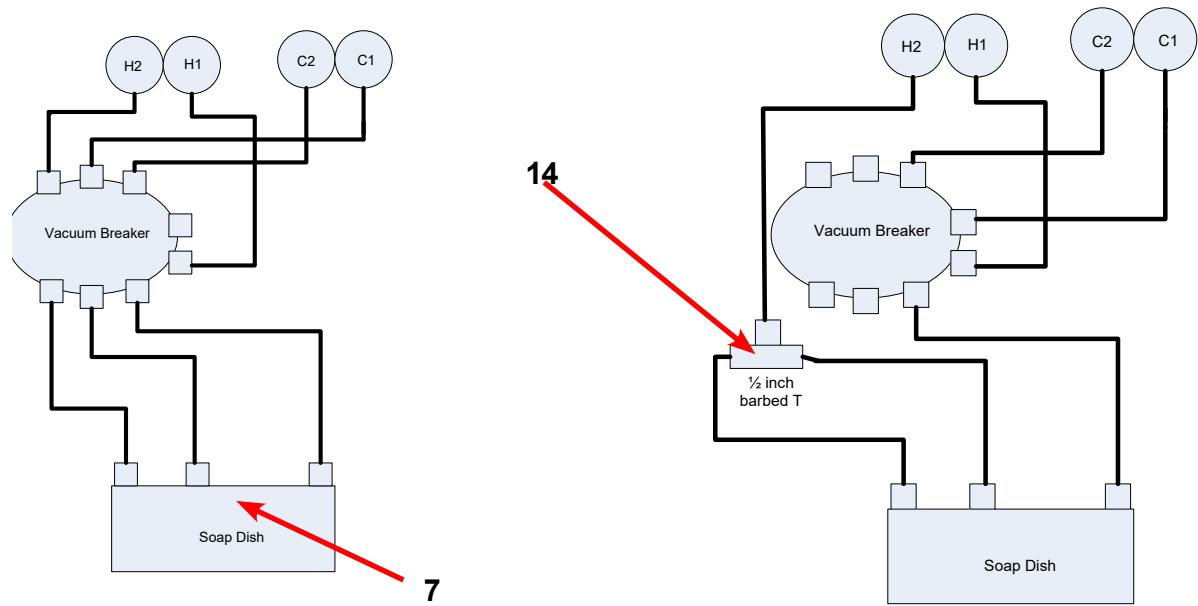
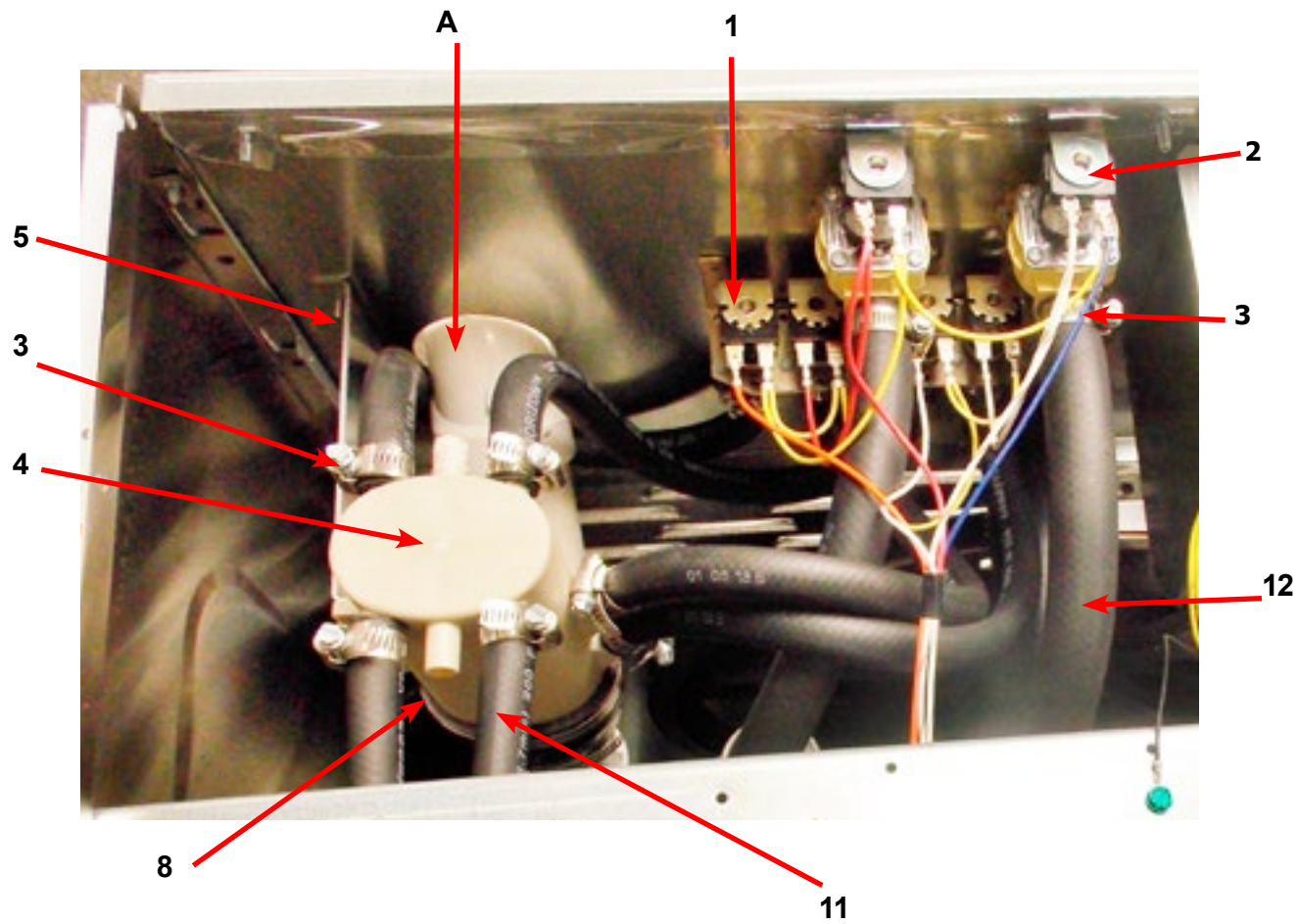

Original Front Soap Box Design

Original Front Soap Box with High Pressure Solution

Water Inlet Part # by Model

Key	Description	T 750	T-900	T-950	T-1200	T-1450	QTY
A	Injector Assembly	9883-005-001	9883-005-001	9883-005-001	9885-005-001	9885-011-001	1
*	Injector Assembly (After 7/2011)		9883-012-001				1
1	Valve, Water Inlet (dual outlet) (see Water Inlet Valve Breakdown for individual parts)	9379-183-003	9379-183-003	9379-183-003	9379-183-003	9379-183-003	2
*	Screw, Valve Mtg	9545-008-026	9545-008-026	9545-008-026	9545-008-026	9545-008-026	2
2	Valve Water Inlet (single outlet)			9379-194-001	9379-194-001	9379-194-001	2
*	Screw, Valve M4x0.7x8mm			9495-064-001	9545-064-001	9545-064-001	8
3	Clamp-Water Valves	8654-117-008	8654-117-008	8654-117-008	8654-117-008	8654-117-008	AR
*	Shield over Water Valves Plastic	9550-186-001	9550-186-001	9550-186-001	9550-186-001	9550-186-001	1
	Screw 10-32x3/4" for shield	9545-012-006	9545-012-006	9545-012-006	9545-012-006	9545-012-006	2
*	Nut #10-32	8640-413-004	8640-413-004	8640-413-004	8640-413-004	8640-413-004	2
4	Vacuum Breaker	9610-001-001	9610-001-001	9610-001-001	9610-001-001	9610-001-001	1
5	Bracket, Vacuum Breaker	9062-069-001					1
*	Screw	9545-008-026	9545-008-026	9545-008-026	9545-008-026	9545-008-026	4
6	New Front Mount Soap Box, 2 port						
7	Fitting, Cross (new soap bhox)				8615-118-001	8615-118-001	
8	Clamp, Vacuum Breaker End	8654-117-014	8654-117-014	8654-117-014	8654-117-014	8654-117-014	1
9	Hose, Vacuum Breaker to Tub Injection Tube	9242-461-001					2
10	Flow restrictor	9475-002-002	9475-002-002	9475-002-002	9475-002-002	9475-002-002	2
11	1/2 inch hose, cut to length						
12	3/4 inch hose, cut to length						
13	Flow restrictor		9475-002-002	9475-002-002	9475-002-003	9475-002-003	3
*	New Soap Box-Front Conversion	9732-290-001	9732-290-001	9732-290-001	9732-290-001	9732-290-001	1
14	Optional High Pressure "T" fitting				8615-116-001	8615-116-001	

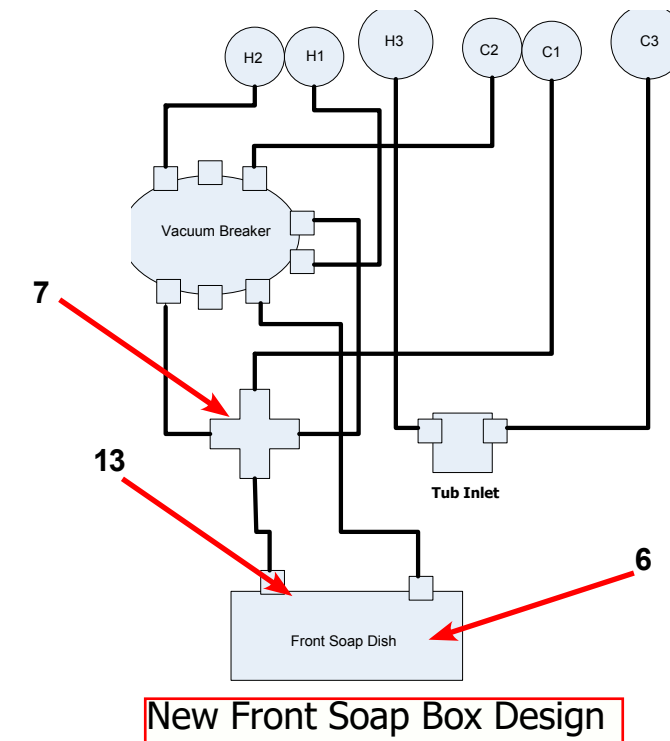

New Front Soap Box Design

Water Inlet Valve Breakdown Part # by Model

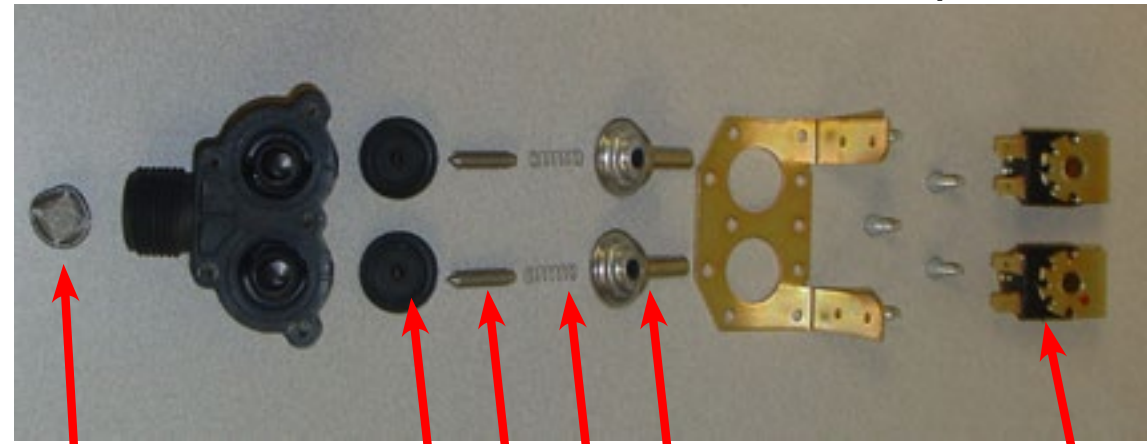

Key	Description	T-750	T-900	T-950	T-1200	T-1450	QTY
*	Valve, Water Inlet (includes 1 thru 6) - Invensys	9379-183-012	9379-183-012	9379-183-012	9379-183-012	9379-183-012	2
1	Screen, Inlet end of valve	9555-056-001	9555-056-001	9555-056-001	9555-056-001	9555-056-001	2
2	Coil Assy., 120 V Invensys	9089-017-001	9089-017-001	9089-017-001	9089-017-001	9089-017-001	2
3	Diaphragm Invensys (EPDM NSF)	9118-049-003	9118-049-003	9118-049-003	9118-049-003	9118-049-003	2
4	Guide, Solenoid Invensys	9211-021-002	9211-021-002	9211-021-002	9211-021-002	9211-021-002	2
5	Armature Invensys	9015-008-001	9015-008-001	9015-008-001	9015-008-001	9015-008-001	2
6	Spring, Armature Invensys	9534-298-001	9534-298-001	9534-298-001	9534-298-001	9534-298-001	2
*	Optional Diaphran (Viaton)	9118-049-002	9118-049-002	9118-049-002	9118-049-002	9118-049-002	2
*	Wiring Harness	9794-001-001			9794-001-001		1

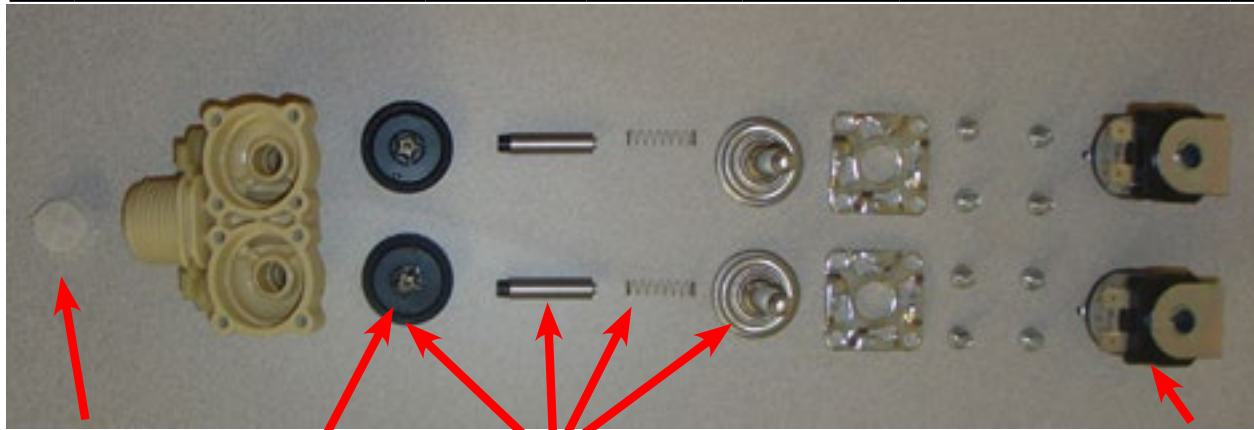

Optional Water Valve

Key	Description	T-750	T-900	T-950	T-1200	T-1450	QTY
*	Dual Coil Water Valve Mueller	9379-192-001	9379-192-001	9379-192-001	9379-192-001	9379-192-001	1
7	Valve Water Body Complete(no coil)	9379-192-002	9379-192-002	9379-192-002	9379-192-002	9379-192-002	1
8	Diaphragm Mueller	9118-054-001	9118-054-001	9118-054-001	9118-054-001	9118-054-001	2
9	Filter Mueller	9183-046-001	9183-046-001	9183-046-001	9183-046-001	9183-046-001	2
10	Coil Mueller	9089-051-001	9089-051-001	9089-051-001	9089-051-001	9089-051-001	2
11	Diaphragm Assembly Mueller Includes	9785-001-001	9785-001-001	9785-001-001	9785-001-001	9785-001-001	2

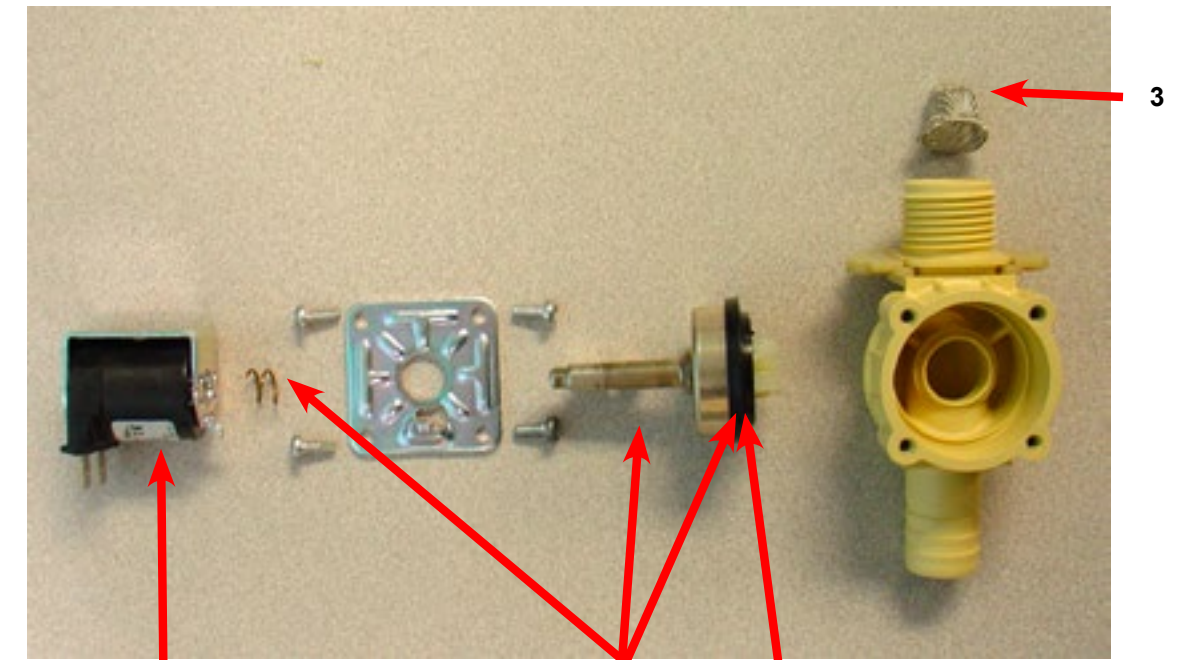

Key	Description	T-750	T-900	T-950	T-1200	T-1450	QTY
*	Single Coil Water Valve Mueller				9379-194-001	9379-194-001	1
1	Valve Water Body Complete (no coil)				9379-194-002	9379-194-002	1
2	Diaphragm Mueller				9118-055-001	9118-055-001	1
3	Filter Mueller				9183-046-001	9183-046-001	1
4	Coil Mueller				9089-051-001	9089-051-001	1

Notes

Drain Valve Group Part # by Model

Key	Description	T-750	T-900	T-950	T-1200	T-1450	QTY
1	Valve, Drain (includes #2 thru #11)	9379-202-001	9379-202-001	9379-202-001	9379-202-001	9379-202-001	1
2	Body, Valve (w/ball)	9064-070-001	9064-070-001	9064-070-001	9064-070-001	9064-070-001	1
3	Motor & Gear Train (complete)	9914-137-011	9914-137-011	9914-137-011	9914-137-011	9914-137-011	1
4	Plate, Motor Mtg	9452-538-001	9452-538-001	9452-538-001	9452-538-001	9452-538-001	1
5	Screw	8639-994-001	8639-994-001	8639-994-001	8639-994-001	8639-994-001	3
6	Spring, Drive	9534-339-001	9534-339-001	9534-339-001	9534-339-001	9534-339-001	1
7	Screw	9545-054-001	9545-054-001	9545-054-001	9545-054-001	9545-054-001	2
8	Screw	9545-054-002	9545-054-002	9545-054-002	9545-054-002	9545-054-002	1
9	Seal, V Packer	9532-134-001	9532-134-001	9532-134-001	9532-134-001	9532-134-001	2
10	Washer	8641-584-001	8641-584-001	8641-584-001	8641-584-001	8641-584-001	1
11	Pin, Main Drive	9451-196-001	9451-196-001	9451-196-001	9451-196-001	9451-196-001	1
*	Plate (spacers needed for replacement motor mtg. plate)	9538-149-001	9451-196-001	9451-196-001	9538-149-001	9451-196-001	4
13	Stator and Coil Assembly	9089-036-004	9089-036-004	9089-036-004	9089-036-004	9089-036-004	1
*	Valve Drain before Serial # 482181	9379-187-001	9379-187-001	9379-187-001	9379-187-001	9379-187-001	1
14	Hose Tub to Drain Valve	9242-459-001	9242-459-001	9242-459-001	9242-459-001	9242-459-001	1
*	Seal Kit	9732-327-001	9732-327-001	9732-327-001	9732-327-001	9732-327-001	*

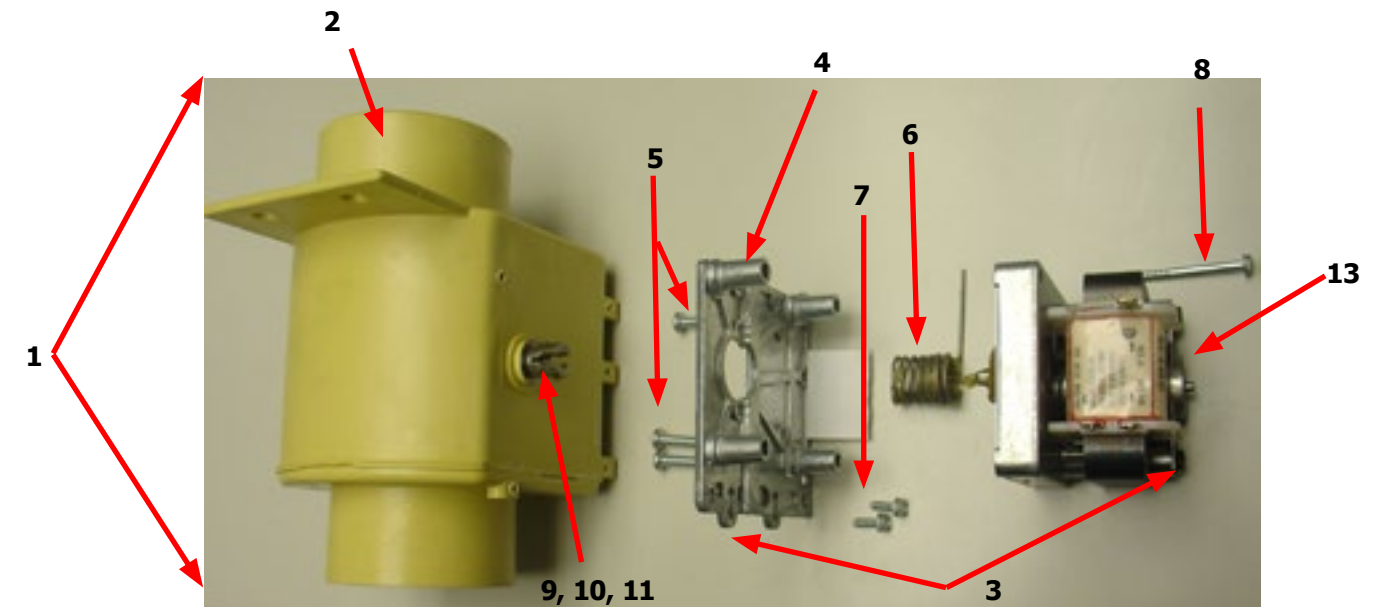

Chassis and Drain Part # by Model

Key	Description	T750	T-900	T950	T-1200	T1450	QTY
1	Base Assy,Frame	9945-112-002	9945-155-002	9945-155-002	9945-125-002	9945-133-002	1
2	Outer Tub Assy Before Serial #535659	9930-148-001	9930-147-001		9930-150-001		1
2	Outer Tub Assy After Serial #535659		9930-157-001	9930-157-001		9930-155-001	1
*	Tub & Cylinder Assy Before Serial #535659	9869-025-001	9869-023-003		9869-022-001		1
*	Tub & Cylinder Assy After Serial #535659		9869-027-003	9869-027-003		9869-026-002	1
3	Tub Front Before Serial #535659	9974-011-001	9974-011-001				1
3	Tub Front After Serial #535659		9974-011-001	9974-011-001	9974-011-001	9974-012-001	1
*	Gasket, Tub Front	9206-421-002	9206-421-002	9206-421-002	9206-421-002	9206-421-002	1
4	Ring Assy, Tub Mtg-Front Clamp	9950-055-001	9950-055-001	9950-055-001	9950-055-001	9950-061-001	1
5	Bolt, Top Front Ring 3/8"-16 x 3"	9545-029-009	9545-029-009	9545-029-009	9545-029-009	9545-029-009	1
6	Nut WCAD 3/8"-16	8640-415-001	8640-415-001	8640-415-001	8640-415-001	8640-415-001	1
7	Ring Assy.Clamp Tub Mtg. to Frame	9950-053-002	9950-053-002	9950-053-002	9950-053-002		1
8	Bolt, 1/2" -13 x 2" Ring	9545-017-013	9545-017-013	9545-017-013	9545-017-013		1
9	Nut, 1/2" -13 Ring	8640-417-005	8640-417-005	8640-417-005	8640-417-005		1
10	Bolt, 1/2" -13 x 2" Rings to Base	9545-017-013	9545-017-013	9545-017-013	9545-017-013	9545-017-013	2
11	Nut, Wizloc 1/2" x 13	8640-417-005	8640-417-005	8640-417-005	8640-417-005	8640-417-005	2
12	Washer, Flat 1/2"	8641-581-026	8641-581-026	8641-581-026	8641-581-026	8641-581-026	2
13	Hose, Tub to Drain Valve	9242-456-001	9242-459-001	9242-459-001	9242-459-001	9242-459-001	1
14	Clamp, Hose (Tub to Drain Valve)	8654-117-014	8654-117-014	8654-117-014	8654-117-014	8654-117-014	2
15	Valve, Drain	9379-187-004	9379-187-004	9379-187-004	9379-187-004	9379-187-004	1
*	Screw, Valve to Base 1/4ABx3/4	9545-030-002	9545-030-002	9545-030-002	9545-030-002	9545-030-002	2
*	Washer, Flat 1/4	8641-581-017	8641-581-017	8641-581-017	8641-581-017	8641-581-018	2
16	Hose, Drain Valve to Tube	9242-457-001	9242-457-001	9242-457-001	9242-457-001	9242-457-002	1
*	Clamp, Hose (Drain Valve to Tube)	8654-117-014	8654-117-014	8654-117-014	8654-117-014	8654-117-014	2
17	Tube Assy, Drain	9915-124-002	9915-120-004	9915-120-004	9915-126-002	9915-129-002	1
18	Clamp, Hose (Tube to Frame Bracket)	8654-117-014	8654-117-014	8654-117-014	8654-117-014	8654-117-014	1
*	Bracket, Drain Tube		9029-162-002	9029-162-002			1
*	Screw Tube (Bracket to Base 1/4Bx3/4)	9545-030-002	9545-030-002	9545-030-002	9545-030-002		4
19	Hose, Overflow Tub To Drain Tube	9242-449-003	9242-449-003	9242-449-003	9242-449-003	9242-449-005	1
*	Clamp, Hose	8654-117-018	8654-117-018	8654-117-018	8654-117-018	8654-117-018	2
20	Tube, Suds overflow	9242-463-004	9242-463-004	9242-463-004	9242-463-004	9242-463-006	1
*	Clamp, Hose	8654-117-008	8654-117-008	8654-117-008	8654-117-008	8654-117-008	2
21	Hose, Pressure switch	9242-175-007	9242-175-007	9242-175-007	9242-175-004	9242-175-004	1
	Clamp, Overflow Hose	8654-117-015	8654-117-015	8654-117-015	8654-117-015	8654-117-015	1

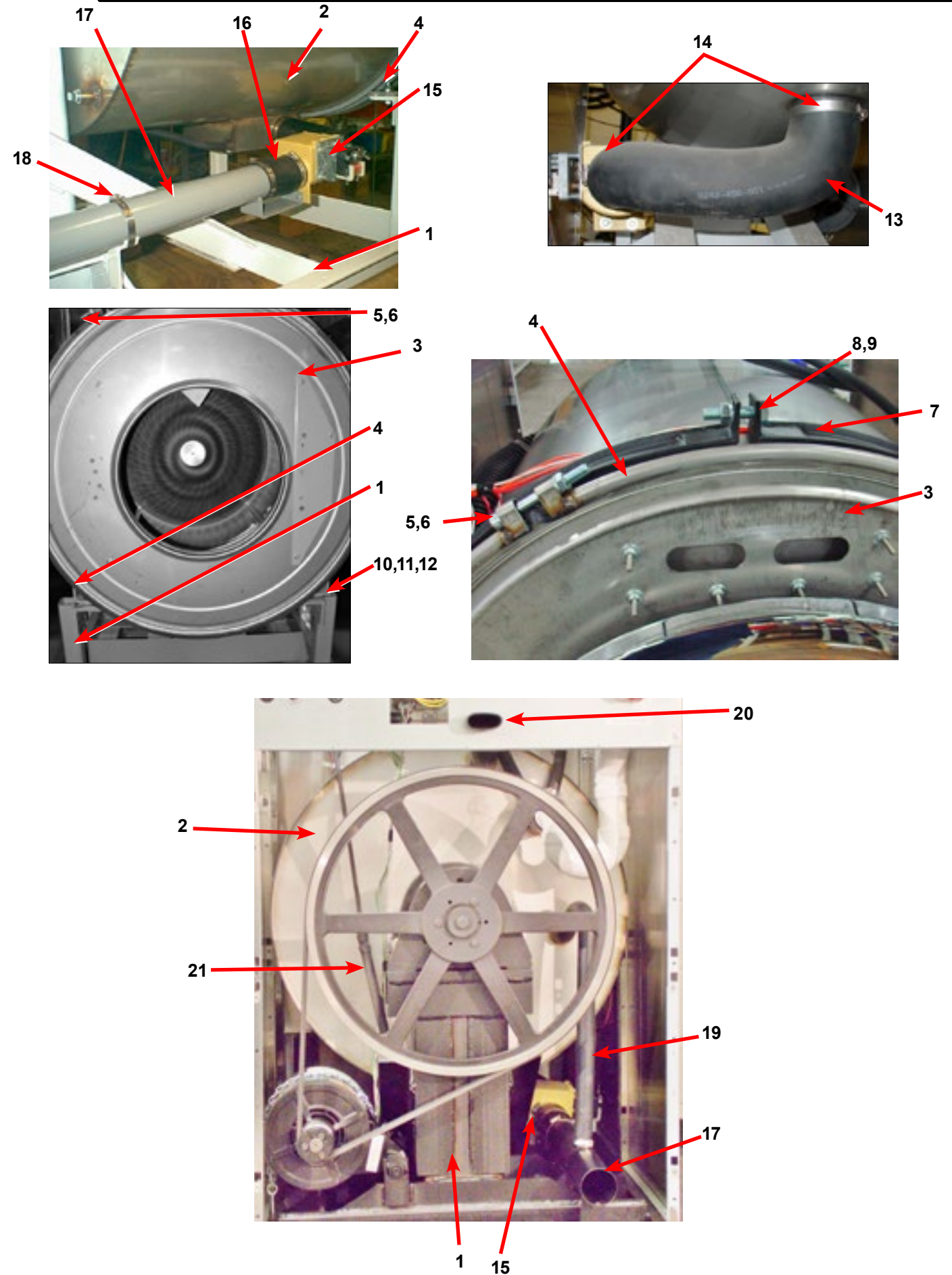

Electrical Components - Top Compartment

Key	Description	T-750	T-900	T-950	T-1200	T-1450	QTY
1	Trough Assy,Controls 208-240 volt (all parts below #2-#43 & trough)	9857-159-001	9857-154-002	9857-154-002	9857-160-002	9857-191-002	1
2	Trough only	9839-015-001	9839-015-001	9839-015-001	9839-015-001	9839-017-001	1
*	Screw, Trough Sides	9545-008-026	9545-008-026	9545-008-026	9545-008-026	9545-008-026	4
*	Lockwasher #10	8641-582-006	8641-582-006	8641-582-006	8641-582-006	8641-582-006	4
*	Angle Support Trough	9003-278-001	9003-271-001	9003-271-001			1
*	Screw, Trough Bracket	9545-008-026	9545-008-026	9545-008-026	9545-008-026	9545-008-026	4
*	Channel-Trough Mounting	9081-110-001	9081-108-001	9081-108-001	9801-110-001	9801-155-001	1
*	Screw-10Bx1/2	9545-008-026	9545-008-026	9545-008-026	9545-008-026	9545-008-026	4
*	Screw GRN. #10-32x 1/2"	9545-008-027	9545-008-027	9545-008-027	9545-008-027	9545-008-027	1
*	Lockwasher #10	8641-582-006	8641-582-006	8641-582-006	8641-582-006	8641-582-006	1
3	Transformer, Control (Secondary Voltage to 115 volts)	8711-004-001	8711-004-001	8711-004-001	8711-004-001	8711-004-001	1
*	Screw, Mtg #8Bx1/4"	9545-045-001	9545-045-001	9545-045-001	9545-045-001	9545-045-001	4
*	Lockwasher #10	8641-582-006	8641-582-006	8641-582-006	8641-582-006	8641-582-006	4
4	Strip, Terminal Marker	9558-027-001	9558-027-001	9558-027-001	9558-027-001	9558-027-001	1
5	Terminal Block Assy, POWER	9897-034-001	9897-034-001	9897-034-001	9897-034-001	9897-034-001	1
*	Screw, Mtg 8Bx3/8"	9545-045-007	9545-045-007	9545-045-007	9545-045-007	9545-045-007	2
6	Transformer, (Step Down) 120/2.3 VAC&24 VAC 50/60hz	8711-009-001	8711-009-001	8711-009-001	8711-009-001	8711-009-001	1
*	Lockwasher #6 exttooth	8641-582-005	8641-582-005	8641-582-005	8641-582-005	8641-582-005	4
*	Screw, Transformer Mtg #8Bx1/4"	9545-045-001	9545-045-001	9545-045-001	9545-045-001	9545-045-001	4
7	PCB assembly Relay Main	9473-006-001	9473-006-001	9473-006-001	9473-006-001	9473-006-001	1
*	Support-3/8" Edge Holding	9548-285-001	9548-285-001	9548-285-001	9548-285-001	9548-285-001	6
8	Optional Relay board	9473-007-001	9473-007-001	9473-007-001	9473-007-001	9473-007-001	1
9	Support-3/8" Edge Holding	9548-285-001	9548-285-001	9548-285-001	9548-285-001	9548-285-001	4
10	Switch, Pressure Before Serial #537433	9539-489-002	9539-489-002		9539-489-002		1
10	Switch, Pressure After Serial #537433	9539-490-001	9539-490-001	9539-490-001	9539-490-001	9539-490-002	1
*	Electronic Pressure Switch	9732-314-001	9732-314-001	9732-314-001	9732-314-001	9732-314-001	*
*	Wire Assy, Enable-Yellow 32"	8220-064-023	8220-064-023	8220-064-023	8220-064-023	8220-064-023	2
*	Harness, P17 Drain/Therm/Sol	9627-796-002	9627-796-002	9627-796-002	9627-796-002	9627-796-002	1
*	Harness P19/Water Valve	9627-795-004	9627-795-002	9627-795-004	9627-795-004	9627-795-004	1
*	Harness P8/P16	9627-794-001	9627-794-001	9627-794-004	9627-794-004	9627-794-001	1
*	Harness P20/P21	9627-793-001	9627-793-001	9627-793-001	9627-793-001	9627-793-001	1
*	Bushing , Wire 7/8	9053-067-002	9053-067-002	9053-067-002	9053-067-002	9053-067-002	2
*	Standoff Twistlock	9527-002-002	9527-002-002	9527-002-002	9527-002-002	9527-002-002	4
11	Dynamic Braking Resistor	9483-004-003	9483-004-003	9483-004-003	9483-004-003	9483-004-003	2
12	Screws #10-32x1/2" (Mounting)	9545-012-008	9545-012-008	9545-012-008	9545-012-008	9545-012-008	4
13	Nuts, #10-32 UNF 2B	8640-413-002	8640-413-002	8640-413-002	8640-413-002	8640-413-002	4
*	Screw #6-32x5/16" (Wire Conn)	9545-044-006	9545-044-006	9545-044-006	9545-044-006	9545-044-006	4
*	Nuts Hex #6-32	8640-411-003	8640-411-003	8640-411-003	8640-411-003	8640-411-003	4
	Screw, Mtg #10Bx1/2"	9545-008-026	9545-008-026	9545-008-026	9545-008-026	9545-008-026	2
*	Harness P5/Pressure	9627-807-001	9627-807-001	9627-807-001	9627-807-001	9627-900-001	1
*	Terminal Grounding,	8652-130-037	8652-130-037	8652-130-037	8652-130-037	8652-130-037	1
*	Screw 10-32 x 1/2 GRN	9545-008-027	9545-008-027	9545-008-027	9545-008-027	9545-008-027	1
*	Lockwasher #10	8641-582-006	8641-582-006	8641-582-006	8641-582-006	8641-582-006	1

Electrical Components - Top Compartment

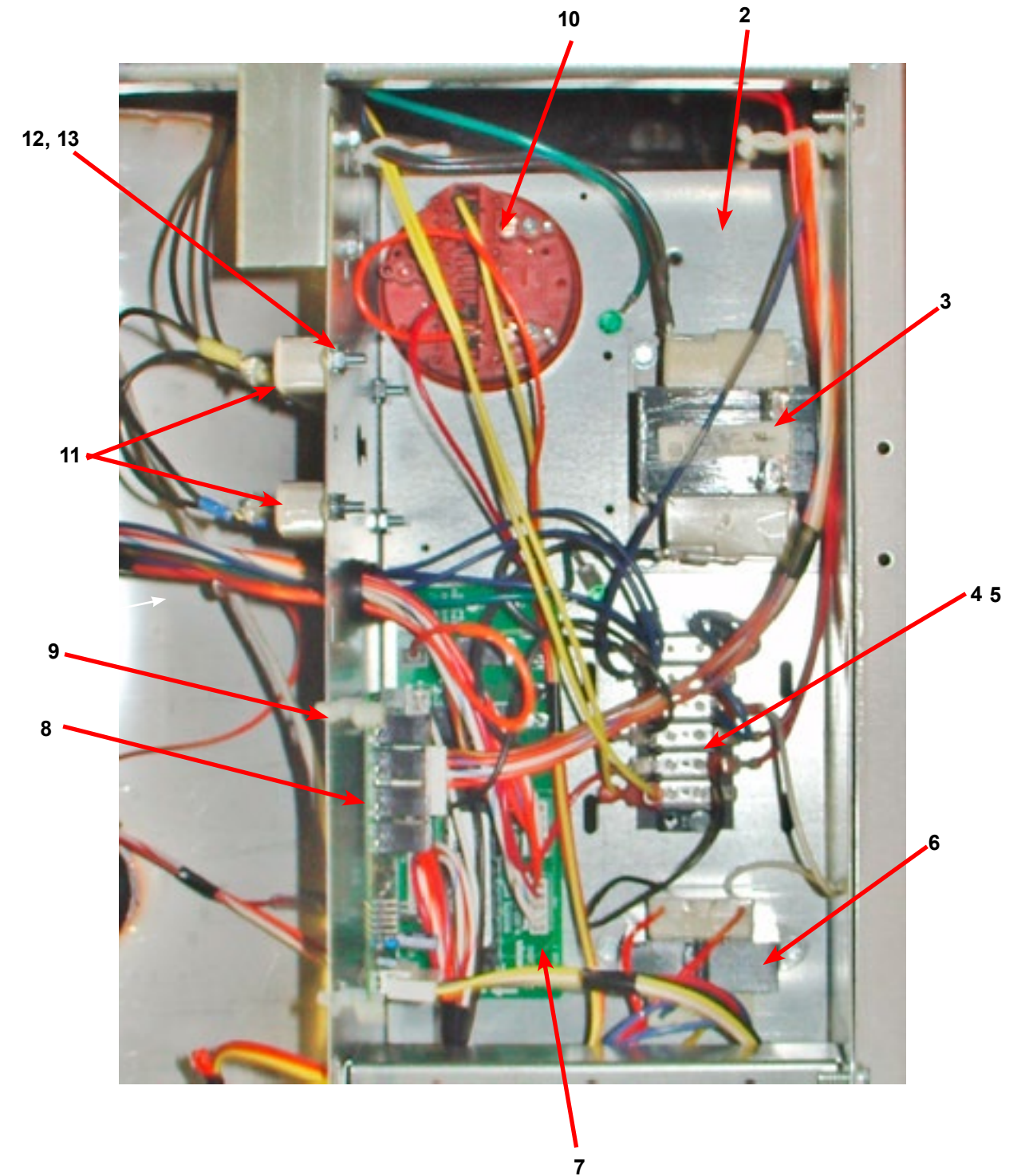

Control Panel Part # by Model

Key	Description	T-750	T-900	T-950	T-1200	T-1450	QTY
1	Panel Control Assembly(panel only) After Serial #530673	9989-480-001	9989-480-001	9989-480-001	9989-480-001	9989-530-001	1
2	Nameplate,Control Panel (one piece) Blue	9412-163-001	9412-119-001		9412-134-001		1
2	Nameplate,Control Panel (one piece) Black	9412-185-001	9412-186-001	9412-187-001	9412-189-001	9412-195-001	1
*	Screw-Hxwshrhnduct #10Bx 1/2"(Control Panel To side Panel)	9545-008-026	9545-008-026	9545-008-026	9545-008-026	9545-008-026	4
	Top Panel						
3	Plastic Shield over main PCB	9550-184-001	9550-184-001	9550-184-001	9550-184-001	9550-184-001	1
4	Nut Hexkeps #8-32	8640-412-005	8640-412-005	8640-412-005	8640-412-005	8640-412-005	3
5	Screw FillHDCR 10Bx1/2" Guide		9545-008-023	9545-008-023	9545-008-023	9545-008-023	1
6	Locator Panel		9355-001-001	9355-001-001	9355-001-001	9355-001-001	1
7	Plate -Latch, Top		9452-625-001	9452-625-001	9452-625-001	9452-625-001	2
8	Nut Hexkeps #8-32		8640-412-005	8640-412-005	8640-412-005	8640-412-005	4
9	Spacer Pushbutton (Micro)	9538-192-001	9538-192-001	9538-192-001	9538-192-001	9538-192-001	1
10	Pushbutton Control (OPL), Blue	9035-060-002	9035-060-002	9035-060-002	9035-060-002	9035-060-002	1
10	Pushbutton Control (OPL), Black	9035-062-003	9035-062-003	9035-062-003	9035-062-003	9035-062-003	1
11	Retainer Pushbutton (Micro)	9486-150-001	9486-150-001	9486-150-001	9486-150-001	9486-150-001	1
12	Nut Hexelasticstop #4-40	8640-424-002	8640-424-002	8640-424-002	8640-424-002	8640-424-002	2
13	Spacer Plastic #6x9/16	9538-157-018	9538-157-018	9538-157-018	9538-157-018	9538-157-018	5
14	PCB assembly Control /Display	9473-004-009	9473-004-009	9473-004-009	9473-004-009	9473-004-009	1
15	Nut Elasticstop #6-32	8640-411-002	8640-411-002	8640-411-002	8640-411-002	8640-411-002	4
16	Nut Hexkeps #6-32	8640-411-003	8640-411-003	8640-411-003	8640-411-003	8640-411-003	1
17	Spacer Plastic #6x9/16	9538-157-018	9538-157-018	9538-157-018	9538-157-018	9538-157-018	2
18	PCB assembly Mode lights	9473-005-001	9473-005-001	9473-005-001	9473-005-001	9473-005-001	1
19	Nut Hexkeps #6-32	8640-411-003	8640-411-003	8640-411-003	8640-411-003	8640-411-003	2
20	Harness-LED PCB, P3	9627-797-001	9627-797-001	9627-797-001	9627-797-001	9627-797-001	1
21	Spacer Plastic #6x9/16	9538-157-018	9538-157-018	9538-157-018	9538-157-018	9538-157-018	2
22	Light, LED,ADD BLEACH Assembly	9794-001-001	9794-001-001	9794-001-001	9794-001-001	9794-001-001	1
23	Nut Hexkeps #6-32	8640-411-003	8640-411-003	8640-411-003	8640-411-003	8640-411-003	2
24	Lock-Run/Program, w/Harness & Key, P2	8650-027-001	8650-027-001	8650-027-001	8650-027-001	8650-027-001	1
*	Key (N561)	6292-006-013	6292-006-013	6292-006-013	6292-006-013	6292-006-013	AR
25	Actuator Assy-Door Locking, 120V	9892-014-001	9892-014-001	9892-014-001	9892-014-001	9892-014-001	1
26	Nut Hexkeps #8-32	8640-412-005	8640-412-005	8640-412-005	8640-412-005	8640-412-005	4
27	Nut-Spring	8640-399-008	8640-399-008	8640-399-008	8640-399-008	8640-399-008	2
*	Screw FillHDCR 10Bx1/2" Guide	9545-008-023					
28	Bracket-Retainer, Front Panel		9029-191-001	9029-191-001	9029-191-001	9029-191-001	1
29	Screw FillHDCR 10Bx1/2" Guide		9545-008-023	9545-008-023	9545-008-023	9545-008-023	2
*	Harness-Optional relay, P23-P15	9627-798-001	9627-798-001	9627-798-001	9627-798-001	9627-798-001	1
*	Harness-PCB to Relay, P8-P16	9627-794-001	9627-794-001	9627-794-001	9627-794-001	9627-794-001	1
*	Harness-Door Lock, P4	9627-791-005	9627-791-005	9627-791-005	9627-791-005	9627-791-005	1
*	Harness-PCB to Enable, P20-P21	9627-793-001	9627-793-001	9627-793-001	9627-793-001	9627-793-001	1
*	Transformer-120V/24/5.3, P7	8711-009-001	8711-009-001	8711-009-001	8711-009-001	8711-009-001	1
*	Harness-Pressure Switch, P5	9627-807-001	9627-807-001	9627-807-001	9627-807-001	9627-900-001	1

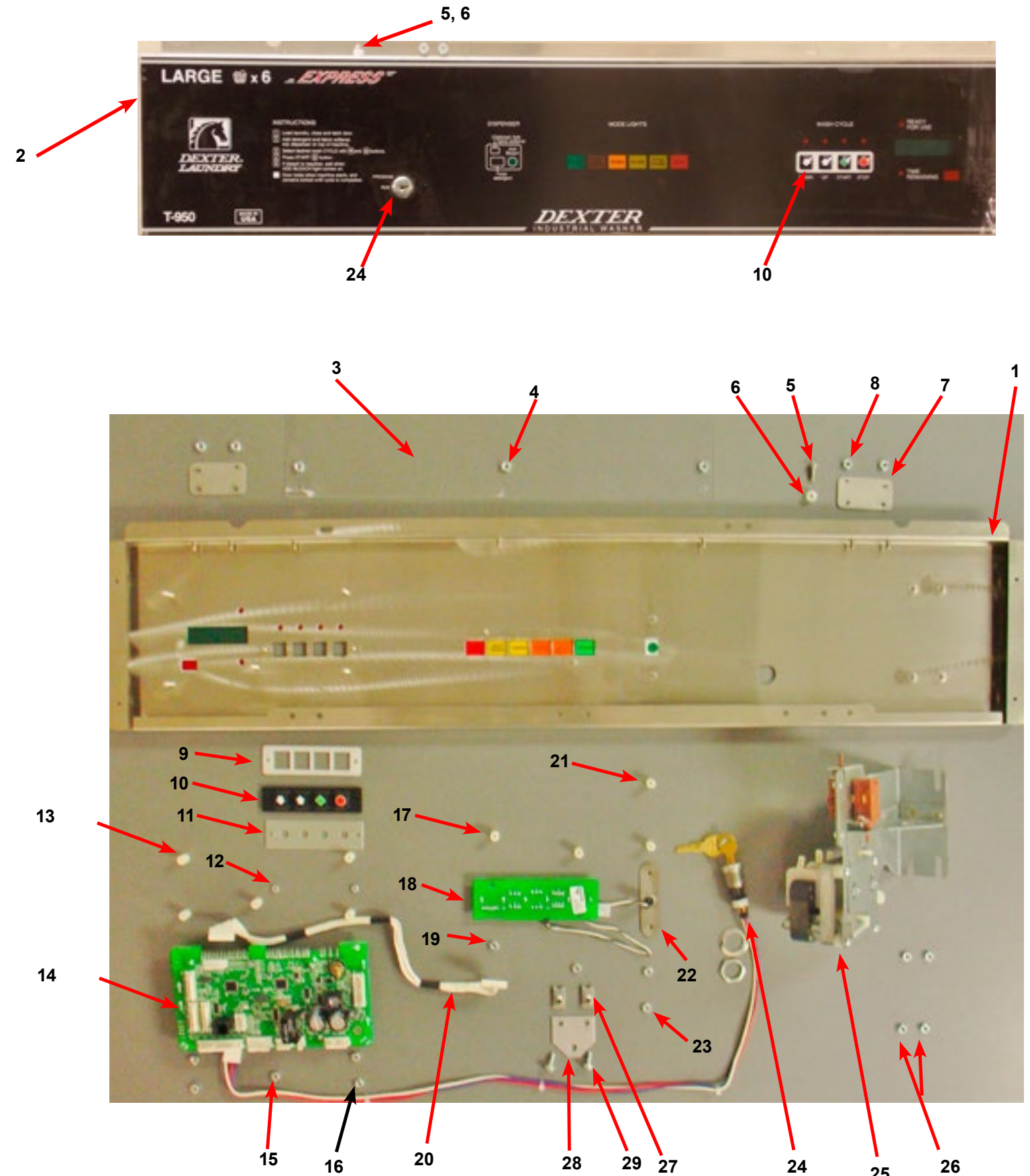

Labels and Diagrams All WCVD Models

Key	Description	T750	T-900	T950	T-1200	T1450	QTY
*	Booklet Owners	8514-160-001	8514-161-001	8514-161-001	8514-162-001	8514-206-001	1
*	Wiring Diagram, Coin	9506-366-001	9506-019-001	9506-487-001	9506-049-001	9506-489-001	1
	Wiring Schematic,	9506-365-001	9506-020-001		9506-050-001		1
*	Transient Voltage Surge Suppressor Infomational	8507-330-001	8507-330-001	8507-330-001	8507-330-001	8507-330-001	1
*	Instructions Spin Direction	8507-275-001	8507-275-001	8507-275-001	8507-275-001	8507-275-001	1
*	Label High Voltage Warning	8502-614-004	8502-614-004	8502-614-004	8502-614-004	8502-614-004	1
*	Label Fusing & Installation	8502-619-003	8502-619-003	8502-619-003	8502-619-003	8502-619-003	1
*	Label Quality	8511-001-002	8511-001-002	8511-001-002	8511-001-002	8511-001-002	1
1	Label Warning Risk of Injury (Blue)	8502-722-002	8502-722-002		8502-722-002		1
1	Label Warning Risk of Injury (Black)	8502-741-001	8502-741-001	8502-741-001	8502-741-001	8502-741-001	1
2	Label Warning Door Opening (Blue)	8502-723-001	8502-723-001		8502-723-001		1
2	Label Warning Door Opening (Black)	8502-742-001	8502-742-001	8502-742-001	8502-742-001	8502-742-001	
3	Label Dispenser (Blue)	8502-687-001	8502-687-001		8502-687-001		1
3	Label Dispenser (Black)	8502-745-001	8502-745-001	8502-745-001	8502-745-001	8502-745-001	1
	Label, Injector Assembly	8502-666-001	8502-666-001	8502-666-001	8502-666-001	8502-666-001	1

Notes



Door Label

2



Risk of Injury Label

1

Top Dispenser Label Front Soap Dish



3

Transformer, Electrical Filter -59 models

Key	Component	T-750	T-900	T-950	T-1200	T-1450	QTY
1	Circuit Breaker	5198-211-002	5198-211-002		5198-211-002		1
*	Harness, Power Terminal block	9627-865-003	9627-865-003		9627-865-003		1
*	Assembly, Control Trough	9857-159-006	9857-154-006		9857-160-006		1
*	Instructions, Transformer Connect	8507-230-003	8507-230-003		8507-230-003		1
2	Control Transformer	8711-008-002	8711-008-002		8711-008-002		1
3	Transformer, Step Down	8711-009-003	8711-009-003		8711-009-003		1
*	Bracket Terminal/Filter Mounting	9029-170-001	9029-170-001		9029-170-001		1
*	Strip, Marker-Injection	9558-028-002	9558-028-002		9558-028-002		1
4	EMI Line Filter	9183-031-003	9183-031-003		9183-031-004		1
5	EMI Filter 1 ph, 24 Amp	9183-045-001	9183-045-001		9183-045-001		1
*	Wiring Schematic	9506-304-001	9506-281-001		9506-285-001		1
*	Wiring Diagram	9506-305-001	9506-282-001		9506-286-001		1
*	Owners Booklet	8514-179-001	8514-181-001		8514-184-001		1

Section :9

Parts 50Hz

Models:

Parts in this section used only in these models. All other parts are same as standard 60 Hz pages.
Wiring Diagrams & Schematics

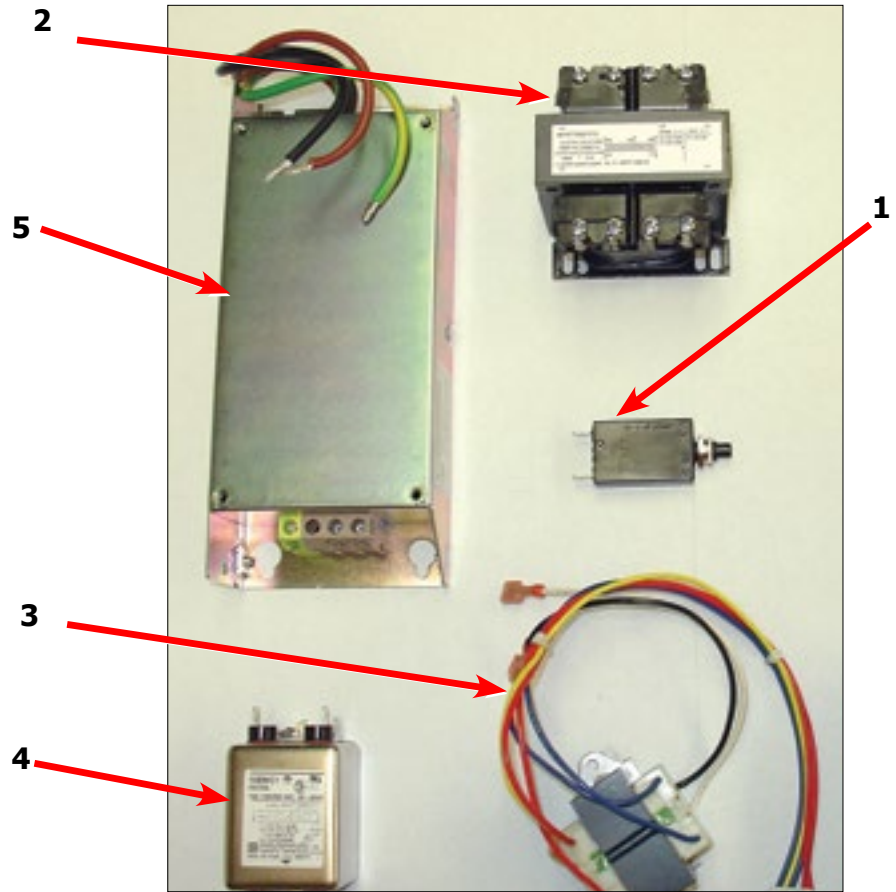

-59 models

Key	Component	T-750	T-900	T-950	T-1200	T-1450	QTY
1	Bracket, Switch-Instability	9029-182-001					1
2	Bracket, Stop-Switch	9029-183-001					1
3	Switch, Instability	9539-487-002					1
4	Wires, Black 48"	8220-127-001					2

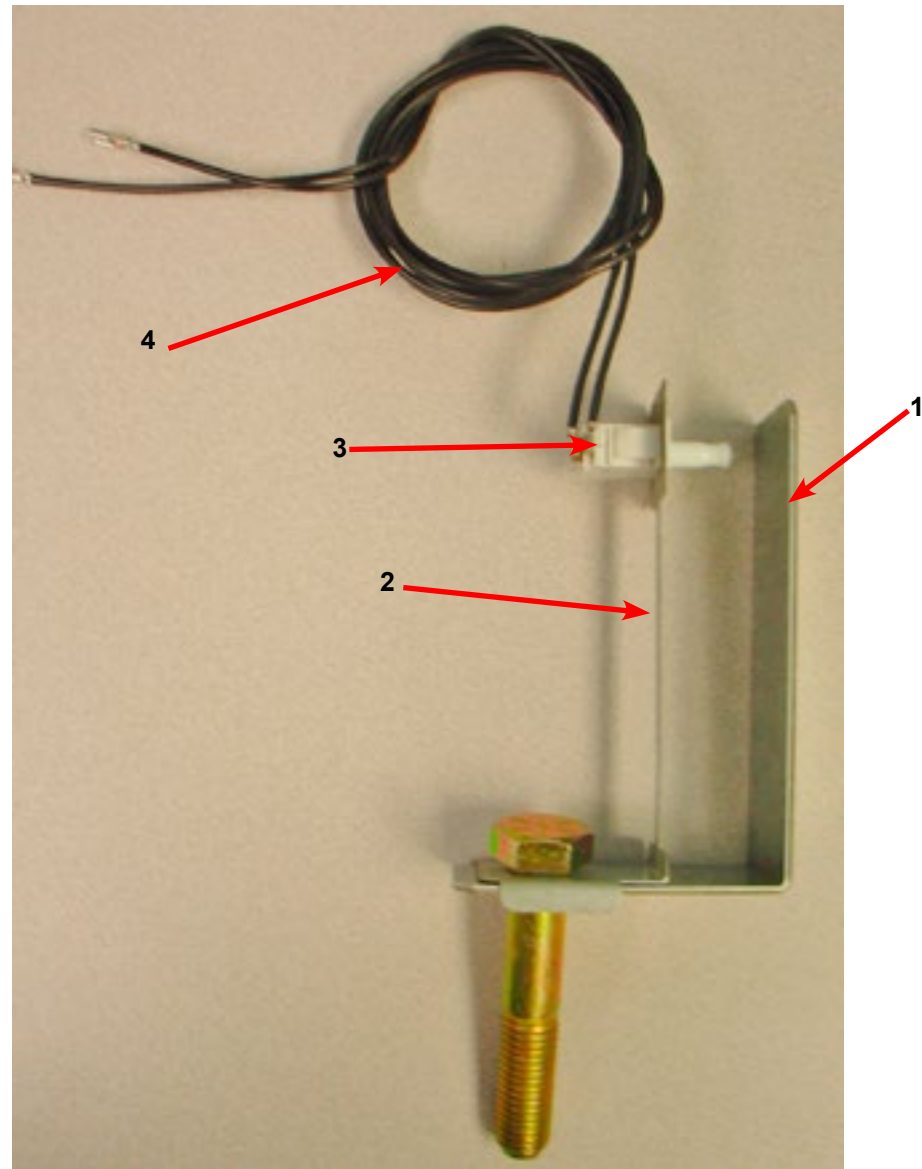

Water Valve, Drain Valve -59 models

Key	Component	T-750	T-900	T-950	T-1200	T-1450	QTY
1	Water Valve (Duel) 24V 50Hz	9379-183-013	9379-183-013		9379-183-013		2
*	Screen, Inlet end of valve	9555-056-001	9555-056-001		9555-056-001		1
*	Diaphragm Invensys (EPDM)	9118-049-001	9118-049-001		9118-049-001		2
*	(Optional) Diaphragm Invensys (Viton)	9118-049-002	9118-049-002		9118-049-002		2
*	Screw #10Bx1/2	9545-008-026	9545-008-026		9545-008-026		2
2	Water Valve Single				9379-194-003		
3	Drain Valve 3" inch	9379-202-002	9379-202-002		9379-202-002		1
*	Hoses, Washer Inlit	9990-027-014					2
*	Hoses, Washer Inlit				9990-027-014		4

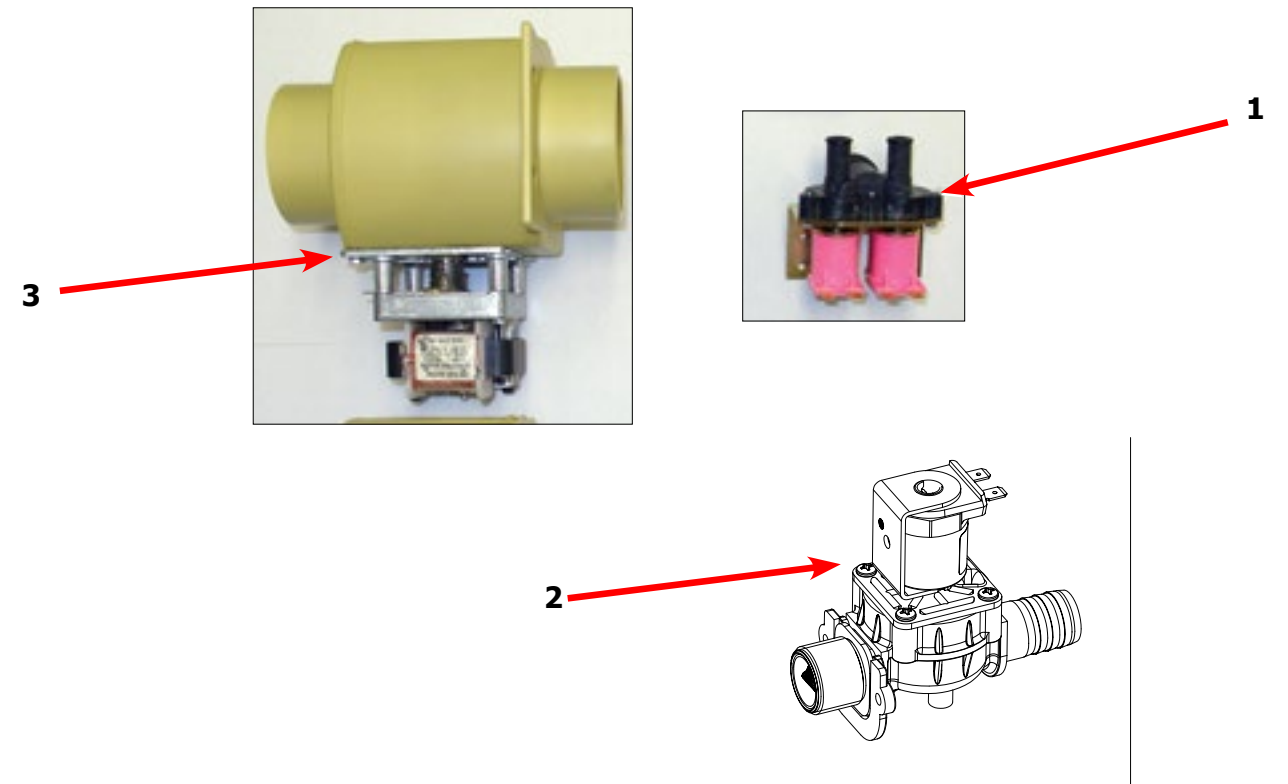

Gear Motor Door Lock Assembly 24V AC

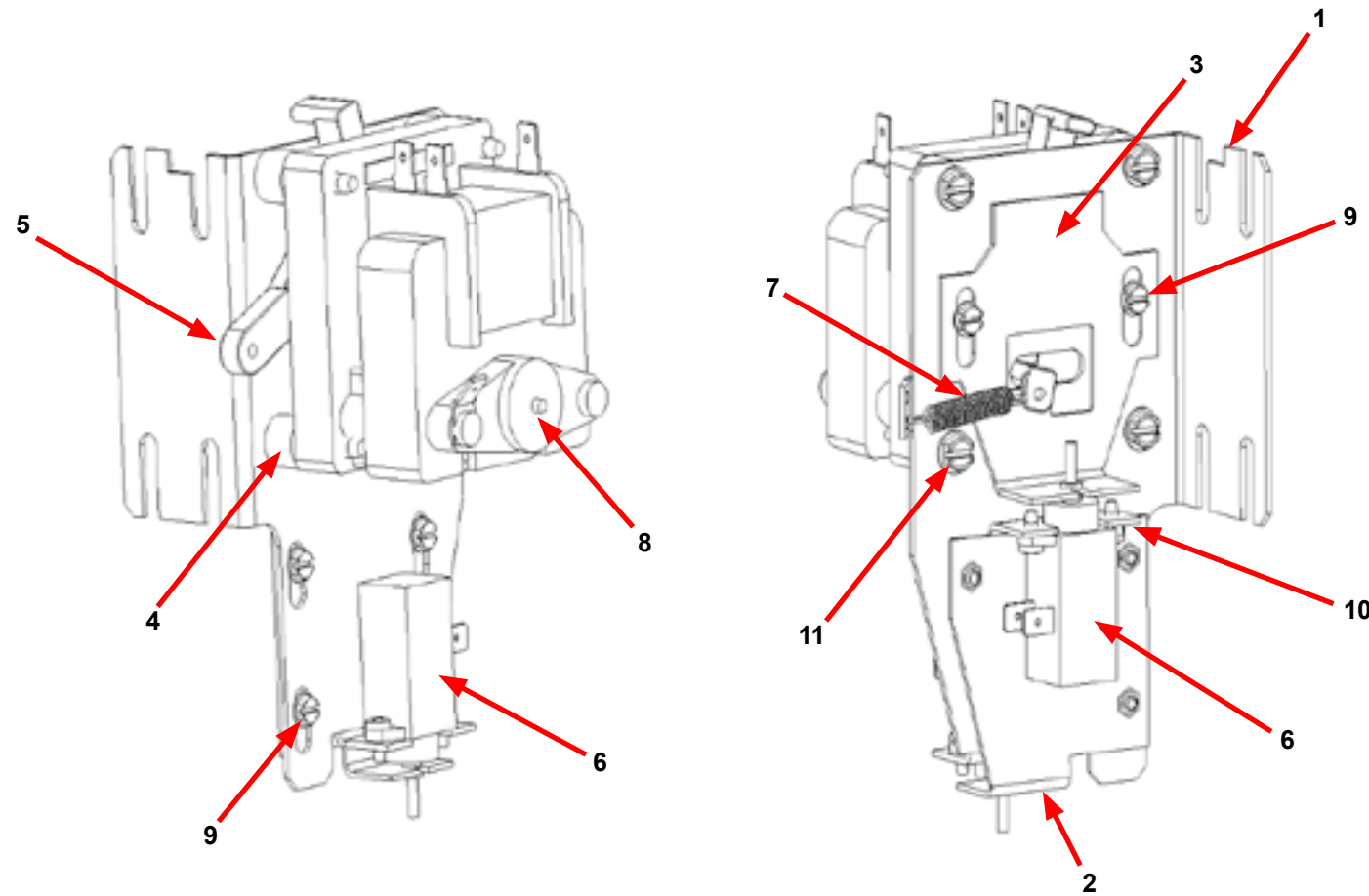

Key	Description	T-750	T-900	T-950	T-1200	T-1450	QTY
*	Actuator Assembly (Includes 1-10, Rod NOT included)	9892-015-002	9892-015-002		9892-015-002		1
11	Screw hxwshdsl, 10-24 - 1.25f, ctd	9545-046-007	9545-046-007		9545-046-007		4
10	Cross Recessed PAn Hd Tapping screw	9545-031-011	9545-031-011		9545-031-011		4
9	Screw -Hxwshrdslsems, 6-32 x 3/16	9545-044-003	9545-044-003		9545-044-003		6
8	Motor & Gear Assembly 24VAC	9914-137-014	9914-137-014		9914-137-014		1
7	Spring - Extension	9534-350-001	9534-350-001		9534-350-001		1
6	Thermoactuator - Door Lock Relay 24VAC	9586-001-003	9586-001-003		9586-001-003		2
5	Arm - Door Lock	9001-063-001	9001-063-001		9001-063-001		1
4	Spacer, Plastic	9538-157-021	9538-157-021		9538-157-021		4
3	Bracket Slide Lock	9029-204-001	9029-204-001		9029-204-001		1
2	Bracket Assy, Slide - Unlock	9985-189-001	9985-189-001		9985-189-001		1
1	Bracket Assy, Slide Lock Actuator	9985-190-001	9985-190-001		9985-190-001		1
*	Rod, Door Lock Before Serial #535659	9497-225-013	9497-225-013				1
*	Rod, Door Lock After Serial #535659		9497-225-015		9497-225-015		1
*	Spacer, Gear Motor	9538-187-001	9538-187-001		9538-187-001		1

Original Door Lock Solenoid Assembly

Key	Description	T-750	T-900	T-950	T-1200	T-1450	QTY
1	Solenoid Ass'y, Door Locking (includes 23 thru 32)	9922-011-001	9922-011-001		9922-011-001		1
2	Bracket, (Door Locking Solenoid)	9029-073-001	9029-073-001		9029-073-001		1
3	Bracket Ass'y, Solenoid Slide	9985-169-001	9985-169-001		9985-169-001		1
4	Solenoid 24V 50 Hz	9536-082-001	9536-082-001		9536-082-001		1
5	Screw, Solenoid Mtg	9545-008-001	9545-008-001		9545-008-001		4
6	Stop, Door Lock Solenoid	9540-033-002	9540-036-001		9540-033-002		1
7	Screw, Shoulder	9545-061-001					1
*	Nut, Keps #6	8640-411-002	8640-411-002		8640-411-002		1
9	Thermoactuator 24V 50Hz	9586-001-003	9586-001-003		9586-001-003		2
10	Screw #6 x 5/16"	9545-031-011	9545-031-011		9545-031-011		4
11	Spacer, Plastic	9538-157-004	9538-157-004		9538-157-004		1
12	Spacer, Metal	9538-166-004	9538-166-004		9538-166-004		1
13	Screw, Cross Recessed	9545-010-001	9545-010-001		9545-010-001		1
14	Nut, Keps #8	8640-412-005	8640-412-005		8640-412-005		1
*	Nut, Sol. Brkt. to Control Panel	8640-412-005	8640-412-005		8640-412-005		3
*	Rod, Pull	9497-225-007	9497-225-007		9497-225-009		1

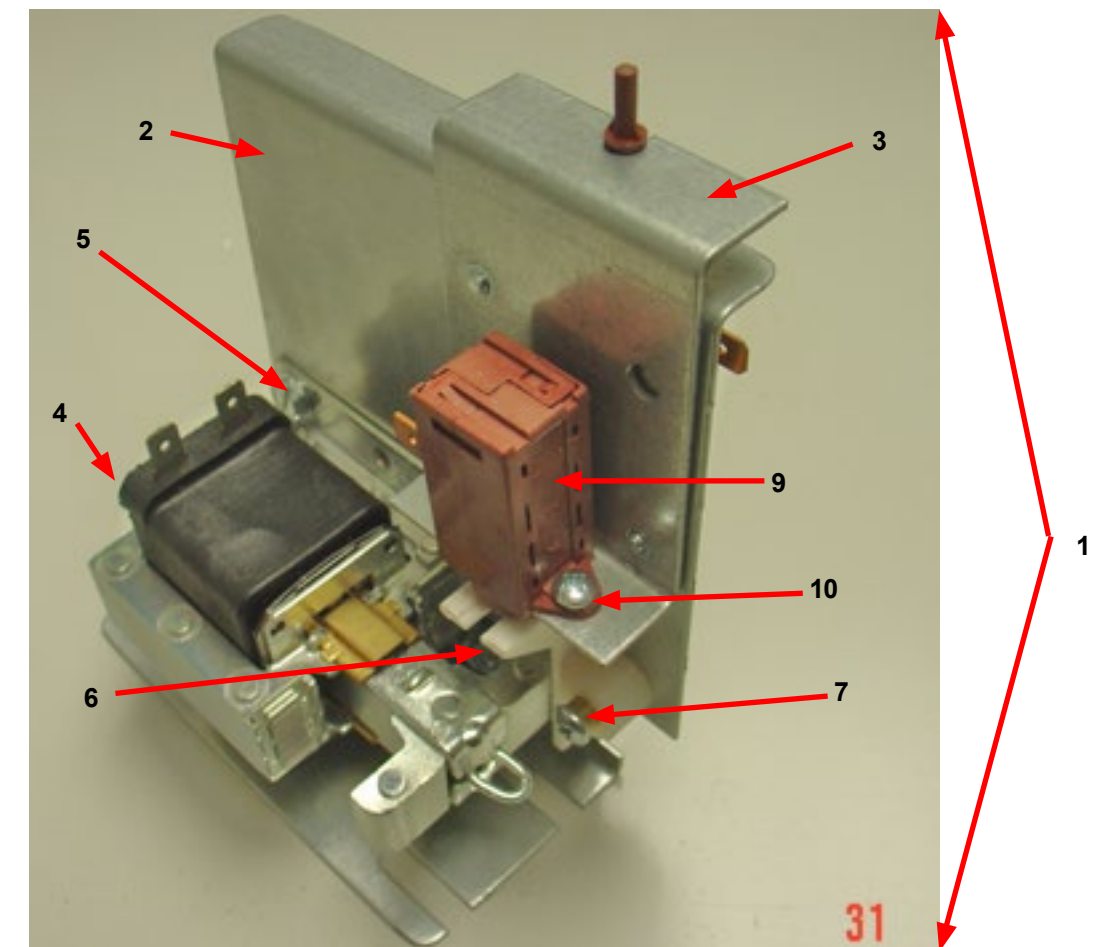

Original Door Lock Solenoid Assembly

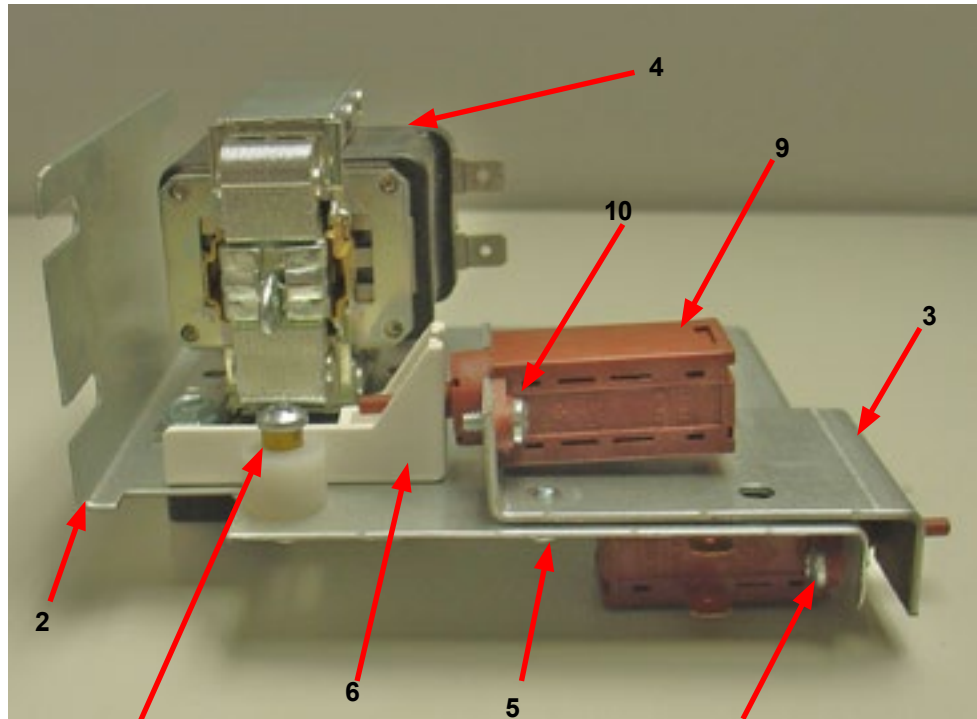

11, 12, 13

WCVD50HC_-59SZ 230V/50/1 Voltage Schematic

