



DEXTER[®]
LAUNDRY

**PLEASE USE THE TABS LOCATED ON THE
RIGHT AND LEFT SIDES OF THE DOCUMENT
TO ADVANCE TO EACH SECTION.**

A-Series Accessories

*WCAD45KC-12SZ 208-240 volts 60hz. Single Phase or Three Phase
(Parts differences for the regular door T-650 will be found on pages 104-105)

WCAD50KC_-12USSZ 208-240 volts 60hz. Single Phase or Three Phase
WCAD60KC_-12USSX 208-240 volts 60hz. Single Phase or Three Phase
WCAD60KC_-12USSZ 208-240 volts 60hz. Single Phase or Three Phase
WCAD80KC_-12USSX 208-240-volts 60hz. Single Phase or Three Phase
WCAD90KC_-12USSZ 208-240 volts 60 hz. Single Phase or Three Phase

Key	Description	T-750	T-900	T-950	T-1200	T-1450	
*	Hose, Water Supply 3/8" I.D. x 48"						2
*	Hose, Water Supply 5/8" I.D. x 48"	9990-027-013	9990-027-013	9990-027-013			2
	Hose, Water Supply 5/8" I.D. x 48"				9990-027-013	9990-027-013	4
*	Washer, Inlet Hose (furnished)	8641-242-000	8641-242-000	8641-242-000	8641-242-000	8641-242-000	2
*	Strainer, Inlet Hose (furnished)	9565-003-001	9565-003-001	9565-003-001	9565-003-001	9565-003-001	2
*	Bevel Washer for 5/8" bolt used in installations using angle iron bases		8641-586-002		8641-586-002		
*	Bevel Washer for 3/4" bolt used in installations using angle iron bases	8641-586-003	8641-586-003	8641-586-003	8641-586-003	8641-586-003	4
*	Sealing compound	8538-151-001	8538-151-001	8538-151-001	8538-151-001	8538-151-001	1
*	TORX#20	8545-051-002	8545-051-002	8545-051-002	8545-051-002	8545-051-003	1
*	Special Tool For Removing Coin Acceptor Mounting Screws. (T-10 Torx)	8545-051-003	8545-051-003	8545-051-003	8545-051-003	8545-051-003	1
*	Flow Restrictors (in dispenser)	9475-002-002	9475-002-002	9475-002-002	9475-002-003	9475-002-002	2
*	Battery (used on Control PCB)	8612-001-001	8612-001-001	8612-001-001	8612-001-001	8612-001-001	1
*	Special Tool for adjusting spacing between outer tub front and cylinder front	8545-056-001	8545-056-001	8545-056-001	8545-056-001	8545-056-001	1
*	VFD Filter options (1 phase) 120v						1
*	VFD Filter options (3 phase)	9732-255-001	9732-255-001	9732-255-001	9732-256-001	9732-255-001	1
*	VFD Filter options (1 phase)	9732-230-001	9732-230-001	9732-230-001	9732-251-001	9732-230-001	1
*	Puller for pushing cylinder out of bearings must be purchased from local sources.						1
*	Clamps to hold tub front to outer tub when installing tub front	Vise Grip #11R	Vise Grip #11R	Vise Grip #11R	Vise Grip #11R	Vise Grip #11R	1
*	Coin Bearing & Seal Kit	9732-219-007	9732-219-007	9732-219-007	9732-219-007		1
*	Coin Op CD with OS2 Platform for A Series Washers Only		9504-015-001		9504-015-001		
	Key Service Lock (6324)	6292-006-007	6292-006-007	6292-006-007	6292-006-007	6292-006-007	1
*	Mode Light Support	9635-022-001	9635-022-001	9635-022-001	9635-022-001	9635-022-001	1
*	MS300 Display	9150-058-001	9150-058-001	9150-058-001	9150-058-001	9150-058-001	*
*	A to C Series Kits	9732-306-007	9732-306-008	9732-306-009	9732-306-010	9732-306-011	*

Kits, Assemblies, & Common Parts

Coin Acceptor Components	Part Number
Optical Coin Acceptor	9021-092-002
Optical Coin Switch Replacement	9801-099-001
Electronic Coin Acceptor (T-1450 only)	9021-077-001
Mechanical Coin Acceptor	9021-001-010
Coin Drop Screws	9545-053-002
Retainer, Coin Acceptor	9486-149-001
Loading Door & Door Lock Components	Part Number
Door Glass Gasket (Large Door)	9206-431-001
Door Glass Gasket (Standard Door)	9206-419-001
Door Handle Only (Large)	9244-091-001
Door Handle Only (Small)	9244-080-003
Door Close Switch	9539-492-001
Door Lock Gear Motor Assembly	9922-015-001
Kit - Door Latching Assy. & Cam (replaces original Door Latching Assembly)	9732-347-001
Kit - Door Cam Replacement	9732-346-002
Kit - Locking Pawl Replacement	9732-346-001
Kit - Door Gasket Expander Kit (Small)	9732-139-001
Kit - Door Gasket Expander Kit (Large)	9732-139-002
Electrical Components	Part Number
Transformer, Main	8711-004-001
Transformer, Control	8711-009-001
Main Control Board	9473-009-005
Kit-Replacement, Pressure Sensor (Only)	9732-315-001
VFD & Breaking Resistors Components	Part Number
Breaking Resistor 200 Ohms	9483-004-002
Breaking Resistor 160 Ohms	9483-004-003
Delta E Drive Display	9150-044-001
MS 300 VFD Display	9150-058-001
Data Cable (56")	9806-015-003
Drain & Water Valve Components	Part Number
Kit - 3" Drain Valve Seal Replacement	9732-327-001
Drain Valve 3"	9379-202-001
Water Valve (Dual)	9379-183-012
Water Valve (Single Mueller)	9379-194-001
Diaphragm (Dual)	9118-049-003
Diaphragm (Single Mueller)	9118-055-001
Cabinet Components	Part Number
Front Panel Screw	9545-008-014
Front Panel Finisher Washer	8641-585-001
Front Panel Spring Nut	8640-399-008
Top Soap Box Screw (Regular Chassis Only)	9545-008-012
Top Soap Box Spring Nut (Regular Chassis Only)	8640-399-007
5/16 Hex Screw, Common	9545-008-026
Top Lock Key #6324	9306-025-001
Cylinder Plug (1.5" Plastic)	9456-041-007



Section 8:

Parts Data
WCAD Vended
Large Chassis

Wiring Harness Part # by Model

Key	Description	T750	T-900	T950	T-1200	T1450	QTY
*	Wiring Harness (Add Bleach Lite assy included)	9794-001-001	9794-001-001	9794-001-001	9794-001-001	9794-001-001	1
*	Wiring Harness, Door Lock	9627-791-005	9627-791-004	9627-791-004	9627-791-005	9627-791-005	1
*	Wiring Harness,CoinDrop Mech	9627-792-001	9627-792-001	9627-895-001	9627-792-001	9627-792-001	1
*	Wiring Harness, Drain,Thermo,DoorSol	9627-796-002	9627-796-002	9627-796-002	9627-796-002	9627-796-002	1
*	Data Cable	9806-015-001	9806-015-001	9806-015-001	9806-015-003	9806-015-003	1
*	Wiring Harness P20/P21	9627-793-001	9627-793-001	9627-793-001	9627-793-001	9627-793-001	1
*	Wiring Harness P8/P16	9627-794-001	9627-794-001	9627-794-001	9627-794-001	9627-794-001	1
*	Wiring Harness WaterValve/P19	9627-795-004	9627-795-004	9627-795-004	9627-795-004	9627-795-004	1
*	Wiring Harness LED PCB	9627-797-001	9627-797-001	9627-797-001	9627-797-001	9627-797-001	1
*	Wiring Harness P5/pressure	9627-803-001	9627-803-001	9627-803-001	9627-803-001	9627-899-001	1
*	Wiring Assembly Yel. 32"		8220-064-023	8220-064-023			2
*	Wiring Assembly Yel. 64"				8220-064-040	8220-064-040	2
*	Wiring Assembly Red 23" #8	8220-063-028					1
*	Wiring Assembly Red 41"				8220-062-032	8220-062-032	2
*	Wiring Assembly Vio. 24"				8220-118-001	8220-118-001	2
*	Wiring Assembly Wht/Brn 8"				8220-108-007	8220-108-007	1
*	Wiring Assembly Jumper Yel	8220-123-001	8220-123-001	8220-123-001	8220-128-001	8220-128-001	1
*	Wire Red Yellow 8"				8220-108-008	8220-108-008	1
*	Wire Yellow Jumper (water valve)				8220-119-002	8220-119-002	1
*	80lb Washer Dispenser Label				8502-687-001	8502-687-001	1
*	Wiring Assembly Red 28" #24	8220-062-025	8220-062-025	8220-062-025			2
*	Wiring Assembly Blk. 17"		8220-062-028	8220-062-028	8220-062-028	8220-062-028	1
*	Wiring Assembly Red 17"		8220-062-027	8220-062-027	8220-062-027	8220-062-027	1
*	Wiring Assembly Jumper BLK.	8220-117-002	8220-117-002	8220-117-002	8220-117-003	8220-117-003	2
*	Wiring Assembly Red 7" #36	9631-381-018	9631-381-018	9631-381-018	9631-381-018	9631-381-018	1
*	Wiring Assembly Blu/Wht	8220-090-009	8220-090-009	8220-090-009	8220-090-009	8220-090-009	1
*	Wiring Assembly Blk/Blu	8220-001-231	8220-001-231	8220-001-231	8220-001-231	8220-001-231	1
*	Wire Assembly Green 7"						1
*	Wire Assembly BLK. 23" #8	8220-063-029					
*	Harness Power Terminal Block	9627-747-003	9627-747-002	9627-747-002	9627-747-002	9627-747-002	1
*	Wire Red Yellow 8"				8220-108-008	8220-108-008	1
*	Wire Yellow Jumper (water valve)				8220-119-002	8220-119-002	1

Cabinet and Front Panel Group Part # by Model Large Door Before Serial # 535659

Key	Description	T-750	T-900	T-950	T-1200	T-1450	
1	Panel, Side (Left or Right) - stainless	9454-812-001					2
1	Panel, Side (Left or Right) - stainless		9454-813-001		9732-359-003		4
*	Strap Assembly (side panel)	9966-013-001	9966-012-001		9966-012-002		4
*	Shim (side panel)	9552-041-001	9552-039-001		9552-042-001		2
*	Screw, (Side Panel to Base)	9545-018-013					6
*	Screw, (Side Panel to Base)		9545-018-013		9545-018-013		8
*	Nut, Hex 1/4-20 UNC (for strap assembly to base)	8640-414-006					6
*	Nut, Hex 1/4-20 UNC (for strap to base)		8640-414-006		8640-414-006		8
2	Bracket, Side Panel under front panel	9046-085-001	9046-085-001		9046-085-001		1
*	Screw #10Bx1/2 side panel brkt	9545-008-026					1
*	Nut 1/4-20 UNC side panel brkt	8640-414-006					1
*	Nut, Hex		8640-413-002		8640-413-002		2
*	Screw		9545-008-024		9545-008-024		2
3	Panel Assy, Front	9454-810-001	9454-810-001		9989-618-002		1
*	Stop Button Mounting Plate	9452-725-001	9452-725-001		9452-725-001		1
*	Band, Edge Protector	9578-072-002					1
4	Bumper Loading Door	9051-055-001	9051-055-001		9051-055-001		1
*	Nut, 1/4 x 20 for bumper	8640-414-006	8643-414-006		8643-414-006		1
*	Screw, Hex- To Control Panel	9545-008-024	9545-008-024		9545-008-024		2
*	Nut, Spring- To Control Panel 10/32	8640-442-001	8640-442-001		8640-442-001		2
5	Screw, Flat Head- Front to Sides	9545-008-014	9545-008-014		9545-008-014		2
5	Screw, Flat Head- Front to Sides						4
6	Washer, Finish	8641-585-001	8641-585-001		8641-585-001		2
6	Washer, Finish						4
*	Nut, Spring-To Front Panel	8640-442-001	8640-442-001		8640-442-001		2
7	Label, Door Opening (Blue)	8502-723-001	8502-723-001		8502-723-001		1
7	Label, Door Opening (Black)	8502-742-001	8502-742-001		8502-742-001		1
8	Panel, Control (Mounts Name-plate)	9989-500-001	9989-500-001		9989-500-001		1
*	Screw, Control Panel to Sides	9545-008-026	9545-008-026		9545-008-026		4
9	Nameplate Decal, Control Blue	9412-162-001	9412-141-001		9412-142-001		1
9	Nameplate Decal, Control Black		9412-165-001				
10	Panel Top	9454-743-001	9454-736-001				1
11A	Panel Top Front				9454-761-001		1
11B	Panel Top Rear				9454-762-001		1
12	Lock, Top (w/Key)	8650-012-003	8650-012-003		8650-012-003		2
13	Door, Lower Service	9960-286-004	9960-286-004		9960-286-004		1
14	Handle (bumper guard)	9244-086-003	9244-086-003		9244-086-003		1
*	Rivet Blind 3/16" Alum		9491-009-003		9491-009-003		4
*	Screw		9545-045-010		9545-045-010		4
15	Screw Mtg., Flat Head 10Bx1 3/4	9545-008-014	9545-008-014		9545-008-014		2
16	Washer, Finish	8641-585-001	8641-585-001		8641-585-001		2
*	Nut, Spring	8640-442-001	8640-442-001		8640-442-001		2

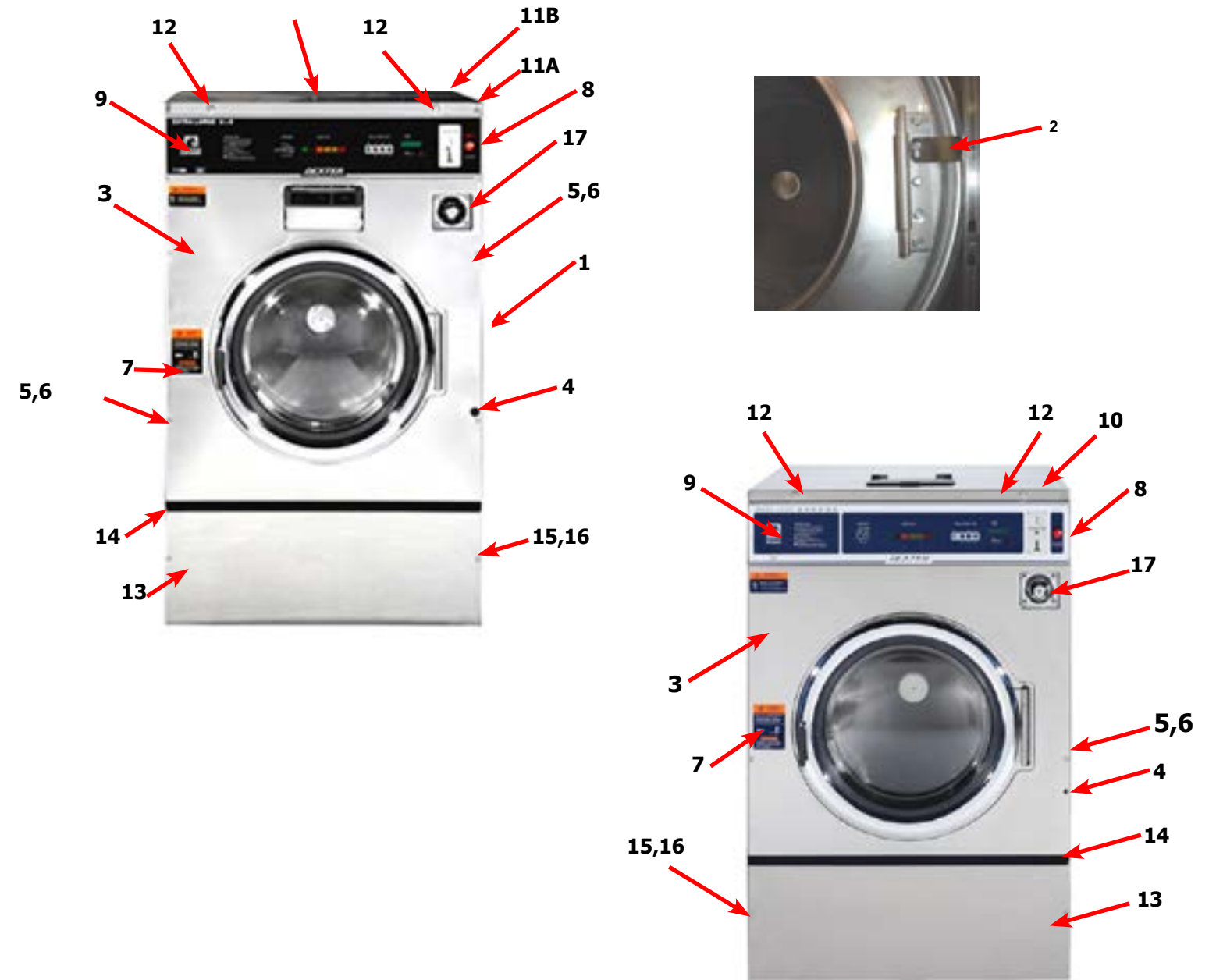

Key	Description	T-750	T-900	T950	T-1200	T1450	QTY
17	Coin Box assy, Large Blue	9807-099-002	9807-099-002		9807-099-002		1
17	Coin Box assy, Large Blue				9807-099-004		
*	Key, Top- # 6324	6292-006-007	6292-006-007		6292-006-007		1
*	Cam, Lock-Top	9095-038-001	9095-038-001		9095-038-001		1
*	Nut, 9/32 - 28 Hex	8640-426-001	8640-426-001		8640-426-001		1
*	Washer Flat 5/16	8641-581-008	8641-581-008		8641-581-008		1
*	Coin Vault, S.S.	9942-037-001	9942-037-001		9942-037-001		1
*	Coin Vault, Black	9942-037-005	9942-037-005		9942-037-005		1
*	Screw, 10B x 1/2	9545-008-026	9545-008-026		9545-008-026		4
*	Chute, Coin	9119-031-001	9119-031-001		9119-028-001		1
*	Screw, Coin Schute	9545-008-001	9545-008-001		9545-008-001		2

Cabinet and Front Panel Group Part # by Model

Large Door After Serial # 535659

Key	Description	T-750	T-900	T950	T-1200	T1450	QTY
1	Panel, Side (Left or Right) - stainless	9454-812-001					2
1	Panel, Side (Left or Right) - stainless		9732-359-002	9732-359-002	9732-359-003	9732-359-004	4
*	Strap Assembly (side panel)	9966-013-001	9966-012-001	9966-012-001	9966-012-002	9966-012-002	2
*	Shim (side panel)	9552-041-001	9552-039-001	9552-039-001	9552-042-001	9552-044-001	
2	Screw, (Side Panel to Base)						6
2	Screw, (Side Panel to Base)		9545-018-013	9545-018-013	9545-018-013	9545-018-013	8
2	Nut, Hex 1/4-20 UNC (for strap assembly)	8640-414-006					6
2	Nut, Hex 1/4-20 UNC		8640-414-006	8640-414-006	8640-414-006	8640-414-006	8
3	Bracket, Side Panel under front panel	9046-085-001	9046-085-001	9046-085-001	9046-085-001	9046-086-001	1
*	Screw #10Bx1/2 side panel brkt	9545-008-026					1
*	Nut 1/4-20 UNC side panel brkt	8640-414-006					1
•	Nut, Hex		8640-413-002	8640-413-002	8640-413-002	8640-414-006	2
*	Screw		9545-008-024	9545-008-024	9545-008-024	9545-008-026	2
4	Panel Assy, Front	9454-810-001	9989-617-002	9989-617-002	9989-618-002	9989-618-002	1
*	Stop Button Mounting Plate	9452-725-001	9452-725-001	9452-725-001	9452-725-001	9452-725-001	1
5	Band, Edge Protector	9578-072-002	9578-092-002	9578-092-002	9578-092-002	9578-092-002	1
*	Bumper Loading Door	9051-055-001	9051-055-001	9051-055-001	9051-055-001	9051-055-001	1
*	Nut, 1/4 x 20 for bumper	8640-414-006	8640-414-006	8640-414-006	8640-414-006	8640-414-006	1
*	Screw, Hex- To Control Panel	9545-008-024	9545-008-024	9545-008-024	9545-008-024	9545-008-024	2
*	Nut, Spring- To Control Panel 10/32	8640-442-001	8640-442-001	8640-442-001	8640-442-001	8640-442-001	2
6	Screw, Flat Head- Front to Sides	9545-008-014	9545-008-014	9545-008-014	9545-008-014	9545-008-014	2
6	Screw, Flat Head- Front to Sides						4
6	Washer, Finish	8641-585-001	8641-585-001	8641-585-001	8641-585-001	8641-585-001	2
6	Washer, Finish						4
*	Nut, Spring-To Front Panel	8640-442-001	8640-442-001	8640-442-001	8640-442-001	8640-442-001	2
7	Label, Door Opening (Blue)	8502-723-001	8502-723-001	8502-723-001	8502-723-001	8502-723-001	1
7	Label, Door Opening (Black)	8502-742-001	8502-742-001	8502-742-001	8502-742-001	8502-742-001	1
8	Panel, Control (Mounts Nameplate)	9989-525-001	9989-525-001	9989-525-001	9989-525-001	9989-529-001	1
*	Screw, Control Panel to Sides	9545-008-026	9545-008-026	9545-008-026	9545-008-026	9545-008-026	4
9	Nameplate Decal, Control Blue	9412-162-001	9412-198-001	9412-191-001	9412-142-001	9412-193-001	1
	Nameplate Decal, Control Black		9412-199-001	9412-192-001	9412-173-001	9412-194-001	
10	Panel Top	9454-743-001	9454-736-002	9454-736-002			1
11A	Panel Top Front				9454-761-001	9454-850-001	1
11B	Panel Top Rear				9454-762-001	9454-851-001	1
12	Lock, Top (w/Key)	8650-012-003	8650-012-003	8650-012-003	8650-012-003	8650-012-003	2
13	Door, Lower Service, Includes Handle	9108-118-001	9960-286-004	9960-286-004	9960-286-004	9960-286-005	1
14	Handle (bumper guard)	9244-086-003	9244-086-003	9244-086-003	9244-086-003	9244-086-004	1
*	Rivet Blind 3/16" Alum	9491-009-003	9491-009-003	9491-009-003	9491-009-003	9491-009-003	4
*	Screw	9545-045-010	9545-045-010	9545-045-010	9545-045-010	9545-045-010	4
15	Screw Mtg., Flat Head 10Bx1 3/4	9545-008-014	9545-008-014	9545-008-014	9545-008-014	9545-008-014	2
16	Washer, Finish	8641-585-001	8641-585-001	8641-585-001	8641-585-001	8641-585-001	2
*	Nut, Spring	8640-442-001	8640-442-001	8640-442-001	8640-442-001	8640-442-001	2

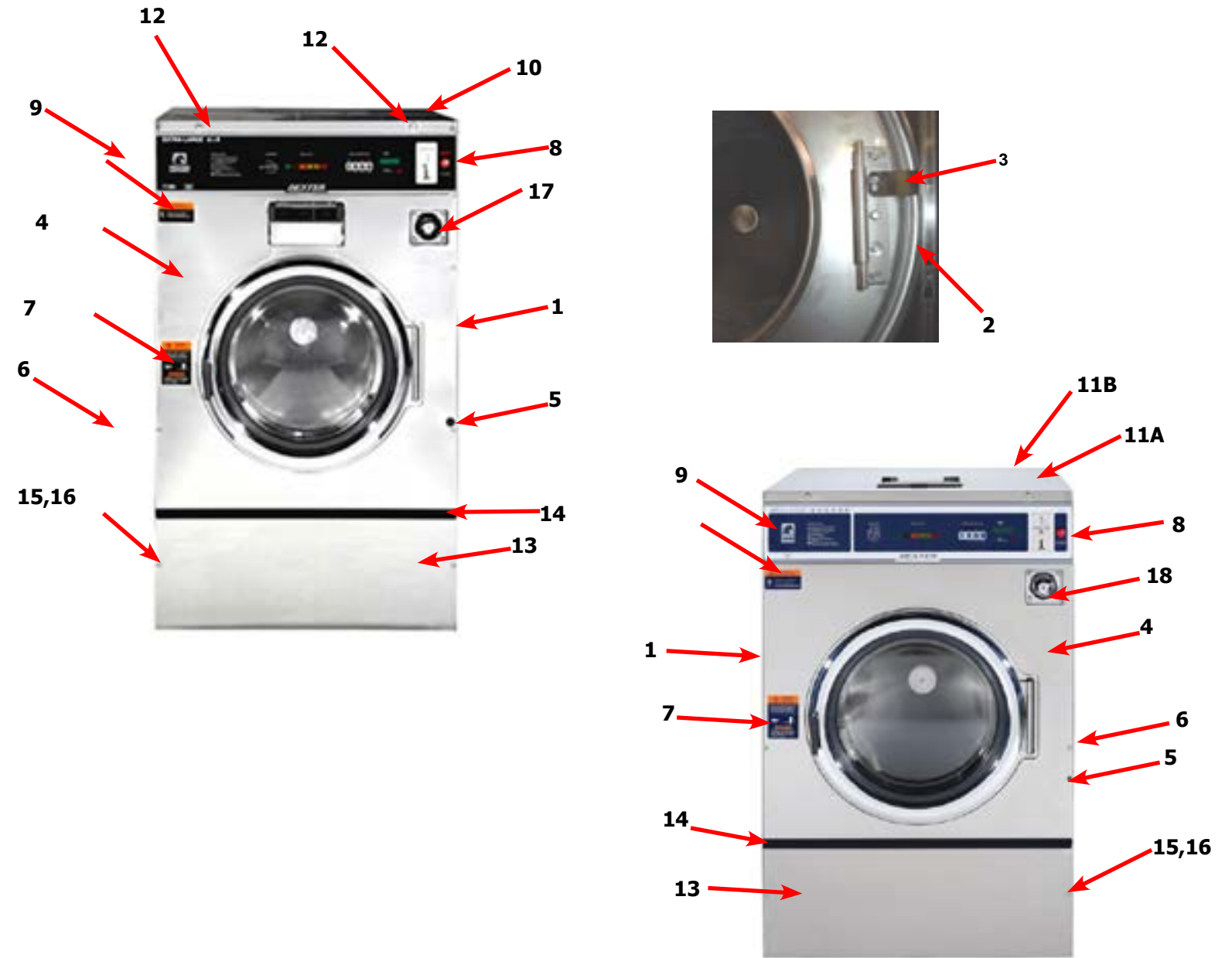

Key	Description	T-750	T-900	T950	T-1200	T1450	QTY
17	Coin Box assy, Large Blue	9807-099-002	9807-099-002	9807-099-002	9807-099-002	9807-099-002	1
17	Coin Box assy, Large Black	9807-099-004	9807-099-004	9807-099-004	9807-099-004	9807-099-004	1
*	Key, Top- # 6324	6292-006-007	6292-006-007	6292-006-007	6292-006-007	6292-006-007	1
*	Lock	8650-012-003	8650-012-003	8650-012-003	8650-012-003	8650-012-003	2
*	Cam, Lock-Top	9095-038-001	9095-038-001	9095-038-001	9095-038-001	9095-038-001	1
*	Nut, 9/32 - 28 Hex	8640-426-001	8640-426-001	8640-426-001	8640-426-001	8640-426-001	1
*	Washer Flat 5/16	8641-581-008	8641-581-008	8641-581-008	8641-581-008	8641-581-008	1
18	Coin Vault, S.S.	9942-037-001	9942-037-001	9942-037-001	9942-037-001	9942-037-001	1
18	Coin Vault, Black	9942-037-005	9942-037-005	9942-037-005	9942-037-005	9942-037-005	1
*	Screw, 10B x 1/2	9545-008-026	9545-008-026	9545-008-026	9545-008-026	9545-008-026	4
*	Chute, Coin	9119-031-001	9119-031-001	9119-028-001	9119-028-001	9119-028-001	1
*	Screw, Coin Schute	9545-008-001	9545-008-001	9545-008-001	9545-008-001	9545-008-001	2

Cabinet and Front Panel Group Part # by Model Front Soap Dish

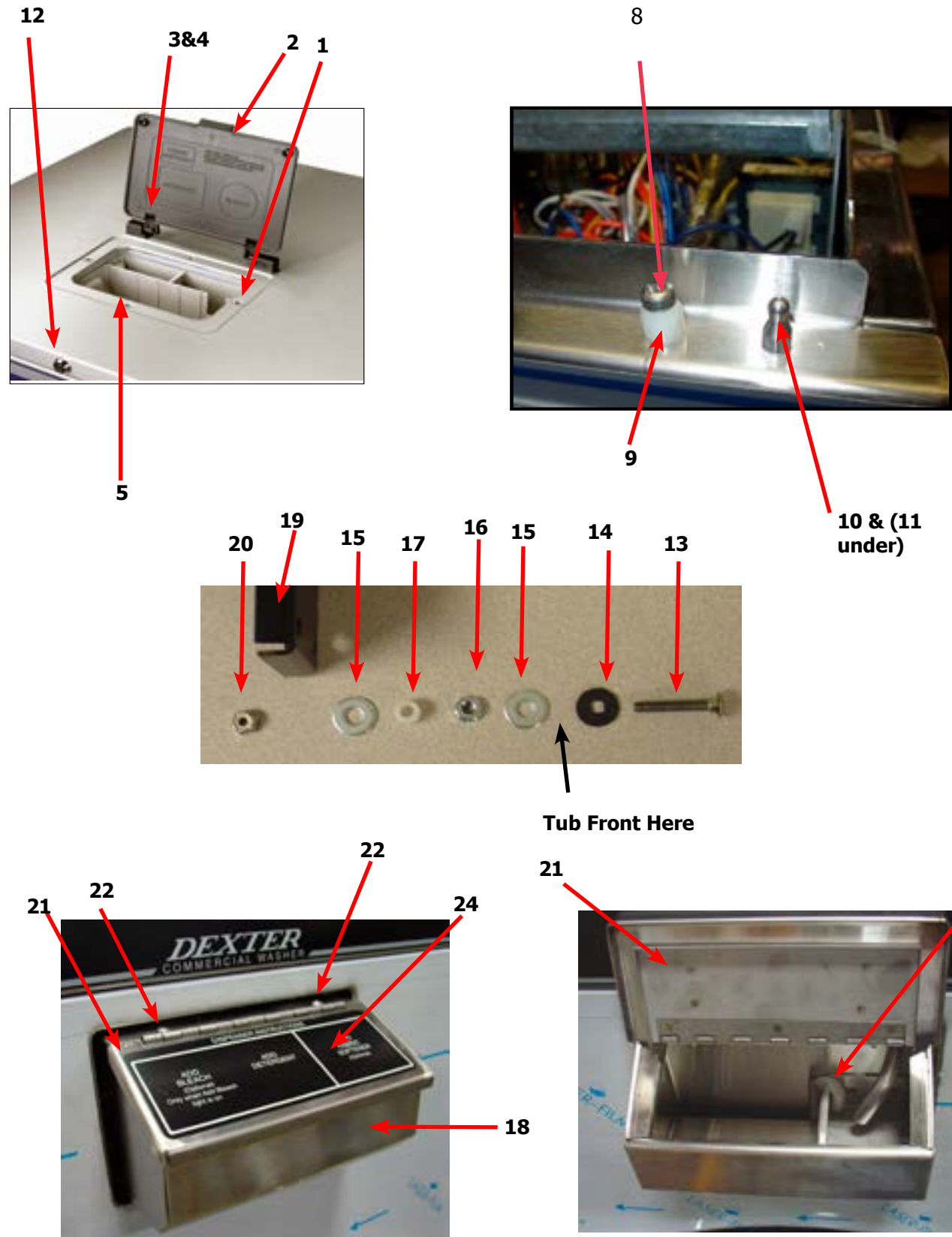

Top Mount Detergent Dispenser

Key	Description	T-750	T-900	T-950	T-1200	T-1450	QTY
1	Dispenser Soap	9122-005-004	9122-005-004				1
*	Nut, Spring ss	8640-399-007	8640-399-007				4
*	Flow restrictors	9475-002-002	9475-002-002				
*	Flow restrictors Optional (Smaller)	9475-002-003	9475-002-003				
2	Door, Dispenser	9108-095-005	9108-095-005				1
3	Pin, Plain	9451-191-001	9451-191-001				2
4	Post, Door Mounting	9467-025-001	9467-025-001				2
5	Screw, SS Dispenser	9545-045-002	9545-045-002				4
*	Washer Flat 5/16	8641-581-008	8641-581-008	8641-581-008	8641-581-008	8641-581-008	1
8	Screw, Locator	9545-008-023	9545-008-023	9545-008-023	9545-008-023	9545-008-023	1
9	Plastic Sleeve, Locator	9355-001-001	9355-001-001	9355-001-001	9355-001-001	9355-001-001	1
10	Locator Post	9467-024-001	9467-024-001	9467-024-001	9467-024-001	9467-024-001	2
11	Nut, Locator Post	8640-411-003	8640-411-003	8640-411-003	8640-411-003	8640-411-003	2
*	Catch, Top Panel	9086-017-001	9086-017-001	9086-017-001	9086-017-001	9086-017-001	2
12	Lock, Top (w/Key)	8650-012-003	8650-012-003	8650-012-003			1
12	Lock, Top (w/Key)				8650-012-003	8650-012-003	2
*	Gasket Dispensor	9206-416-001	9206-416-001				
*	Hose, Dispensor to tub	9242-450-001	9242-450-001				1
*	Clamp	8654-117-008	8654-117-008				2

Front Mount Detergent Dispenser

Key	Description	T-750	T-900	T-950	T-1200	T-1450	QTY
13	Bolt, #10-32 x 1 1/4"SS		9545-012-026	9545-012-026	9545-012-026	9545-012-026	6
14	Special Washer, Rubber		8641-222-000	8641-222-000	8641-222-000	8641-222-000	6
*	Tub Front		9974-011-002				1
15	Washer-Flat, 1/4		8641-581-018	8641-581-018	8641-581-018	8641-581-018	12
16	Nut, #10-32UNF		8640-413-002	8640-413-002	8640-413-002	8640-413-002	6
17	Spacer Plastic #10x1/2		9538-157-019	9538-157-019	9538-157-019	9538-157-019	6
18	Soap Dispenser (no lid)		9807-087-001	9807-087-001	9807-087-001	9807-087-001	1
*	Det. Dispenser Mtg Gasket to Tub frnt		9206-425-001	9206-425-001	9206-425-001	9206-425-001	1
19	Bracket Soap box mounting		9029-122-002	9029-122-002	9029-122-002	9029-122-002	1
20	Nut Hex Elasticstop #10-32 SS mtg dispenser		8640-413-006	8640-413-006	8640-413-006	8640-413-006	6
21	Lid Assembly dispenser		9987-104-001	9987-104-001	9987-104-001	9987-104-001	1
22	Lid screws #10-32x1/2 SS		9545-012-017	9545-012-017	9545-012-017	9545-012-017	2
23	Softner siphon tube (plastic)		9574-252-002	9574-252-002	9574-252-002	9574-252-002	1
*	Flow restrictors		9475-002-003	9475-002-003	9475-002-003	9475-002-003	AR
24	Washer Dispenser Label Blue		8502-687-001	8502-687-001	8502-687-001	8502-687-001	1
24	Washer Dispenser Label Black		8502-745-001	8502-745-001	8502-745-001	8502-745-001	1

Rear View Access Part # by Model

Key	Description	T-750	T-900	T-950	T-1200	T-1450	QTY
1	Drive Motor, 3 Phase	9376-298-001	9376-308-001	9376-298-001	9376-298-001	9376-326-001	1
1	Drive Motor After serial #553489	9376-329-001		9376-329-001	9376-329-001		1
2	Rod, Motor Mtg	9497-222-004	9497-222-004	9497-222-004	9497-222-004	9497-222-004	1
3	Collar, Shaft (w/set screws) (old)	9076-052-002	9076-052-002		9076-052-002	9076-052-002	2
*	Motor Bushing (plastic)	9053-074-001	9053-074-001	9053-074-001	9053-074-001	9053-074-001	1
4	New motor bushing support	9053-082-001	9053-082-001	9053-082-001	9053-082-001	9053-082-001	2
5	Clamp for motor bushing	8654-117-019	8654-117-019	8654-117-019	8654-117-019	8654-117-019	2
6	Pulley, Motor	9453-179-001	9453-175-002	9453-175-002	9453-175-002	9453-175-002	1
*	Split TaperBushing (motor pulley)	9053-077-001	9053-077-001	9053-077-001	9053-077-001	9053-077-001	1
*	Screw taper bushing 1/4-20x1	9545-018-024	9545-018-024	9545-018-024	9545-018-024	9545-018-024	3
7	Bolt, Eye (1/4"-20x1/2")	9545-055-001	9545-055-001	9545-055-001	9545-055-001	9545-055-001	1
*	Nut, 1/4 Elastic Stop	8640-414-003	8640-414-003	8640-414-003	8640-414-003	8640-414-003	1
*	Link (open end)	9341-046-001	9341-046-001	9341-046-001	9341-046-001	9341-046-001	1
8	Chain (Spring Tension)	9099-012-003	9099-012-003	9099-012-003	9099-012-004	9099-012-004	1
9	Spring, Belt Tension	9534-151-000	9534-151-000	9534-151-000	9534-151-000	9534-151-000	1
10	Pulley, Driven	9453-173-002	9453-176-005	9453-176-005	9453-176-005	9453-176-005	1
*	Tolerance Ring	9487-234-004					1
*	Screw, 5/8"-11 x 2"	9545-060-004					1
*	Washer-Flat, 5/8"	8641-582-032					1
*	Washer-Flat, 5/8"	8641-582-018					1
11	Bolt, 3/8"-16 x 2"		9545-029-011	9545-029-011	9545-029-011	9545-029-011	3
12	Washer, 3/8"		8641-582-003	8641-582-003	8641-582-003	8641-582-003	3
*	Bushing Taperlock (Pulley)		9053-078-002	9053-078-002	9053-078-002	9053-078-002	1
13	Washer-Flat .675x2-1/2x1/4	8641-581-043	8641-581-043	8641-581-043	8641-581-043		1
14	Lockwasher-Exttooth, 5/8	8641-582-018	8641-582-018	8641-582-018	8641-582-018		1
15	Bolt, 5/8-11x1 1/2	9545-060-001	9545-060-001	9545-060-001	9545-060-001		1
13	Washer-Flat, .781x2-1/2x1/4					8641-581-044	1
14	Lockwasher-Exttooth, 3/4					8641-582-020	1
15	Bolt, 3/4-10-1 1/2					9545-057-004	1
16	Drive Belt		9040-079-002	9040-079-002	9040-079-003	9040-079-006	1
16	Drive Belt	9040-076-008					2
17	Hose, Overflow to drain	9242-449-003	9242-449-003	9242-449-003	9242-449-003	9242-449-005	1
18	Clamp, Hose overflow to drain	8654-117-018	8654-117-018	8654-117-018	8654-117-018	8654-117-018	2
19	Hose, Overflow Vent Top	9242-463-004	9242-463-004	9242-463-004	9242-463-004	9242-463-004	
*	Clamp, Hose Vent	8654-117-008	8654-117-008	8654-117-008	8654-117-008	8654-117-008	1
*	Vacuum Breaker ALL	9610-001-001	9610-001-001	9610-001-001	9610-001-001	9610-001-001	1
*	Clamp, Hose to Vacuum Breaker	8654-117-014	8654-117-014	8654-117-014	8654-117-014	8654-117-014	1
20	Hose, Vacuum Breaker to tub	9242-458-003	9242-458-003	9242-458-003	9242-458-003	9242-458-003	1
*	Vacuum Breaker Bracket	9029-069-001	9029-069-001	9029-069-001	9029-069-001	9029-069-001	1
21	Inlet Cap		0935-135-001	0935-135-001			2
22	Hose, Pressure Switch	9242-175-007	9242-175-007	9242-175-007	9242-175-004	9242-175-004	1
*	Clamp, Overflow Hose	8654-117-015	8654-117-015	8654-117-015	8654-117-015	8654-117-015	1
23	VFD Delta "S" drive 208-240 volt	9732-345-009	9732-345-004		9732-345-005		1
23	"S" Drive After serial #553489	9375-014-023			9375-014-025		
23	VFD Delta "E" drive 208-240 volt			9375-028-002		9375-029-002	
23	"E" Drive After serial #553489			9375-028-006			
24	Braking resistors (160 ohm)	9483-004-003	9483-004-003		9483-004-003		2
*	Bracket assembly (drive mount)	9029-157-001	9029-157-001	9029-212-001	9029-150-001	9029-216-001	1
25	Channel, Rear, Before Serial #	9081-148-001	9081-148-001		9081-140-001		1
25	Channel, Rear, After Serial #		9081-152-001	9081-152-002		9081-153-001	1

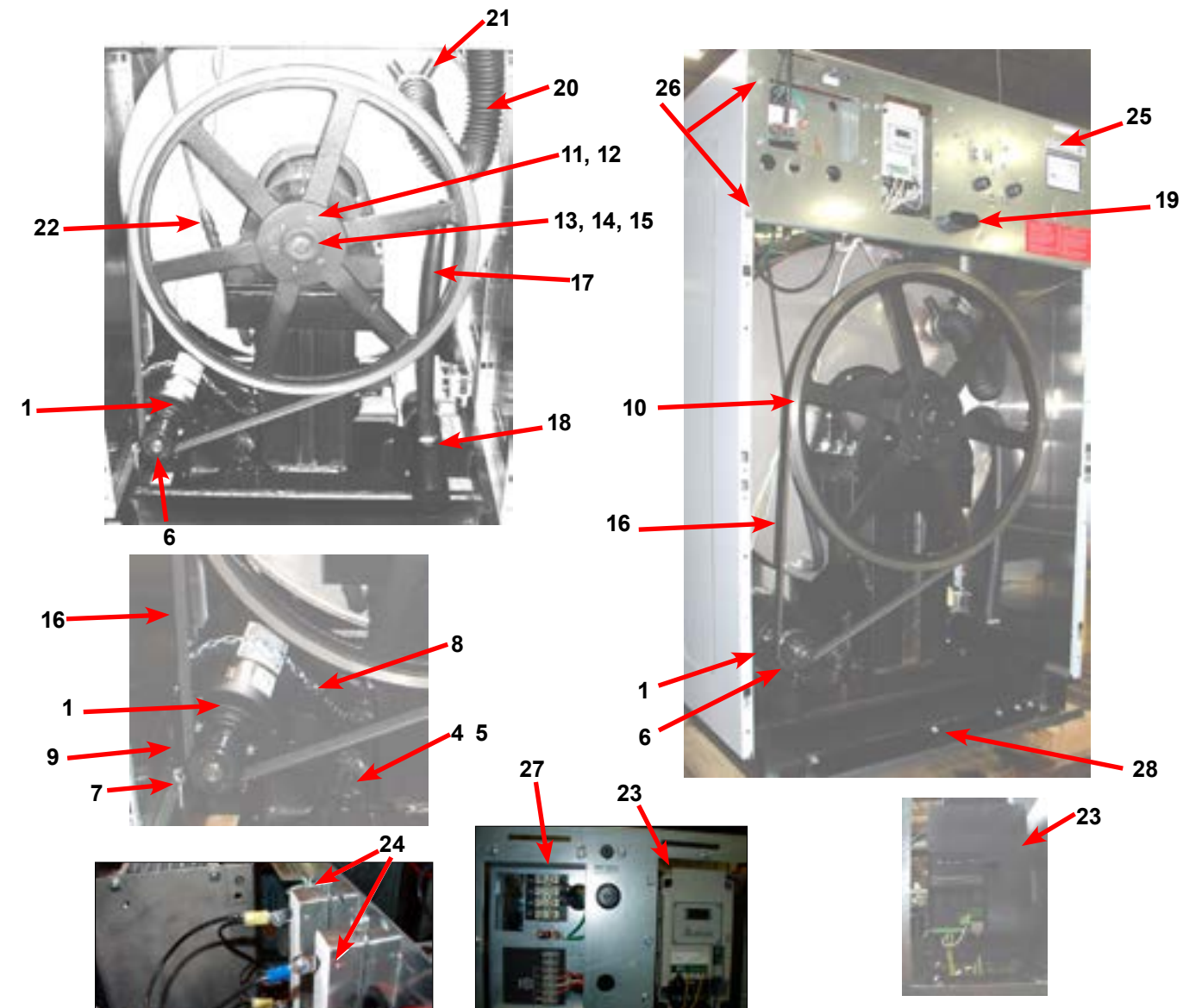

Key	Description	T-750	T-900	T-950	T-1200	T-1450	QTY
26	Screw #10Bx1/2	9545-008-026	9545-008-026	9545-008-026	9545-008-026	9545-008-026	4
*	Nut, Spring	8640-399-007	8640-399-007	8640-399-007	8640-399-007	8640-399-007	4
*	Cover, Terminal Block		9074-267-001	9074-267-001	9074-267-001	9074-267-001	1
*	Screw #10Bx1/2	9545-008-026	9545-008-026	9545-008-026	9545-008-026	9545-008-026	1
-*	Cover, VFD, Before Serial #935659	9074-278-001	9074-278-001	9074-278-001	9074-278-001	9074-278-001	1
*	Cover, VFD, After Serial #935659		9074-342-001	9074-342-001	9074-299-001	9074-299-001	1
*	Screw #10Bx1/2	9545-008-026	9545-008-026	9545-008-026	9545-008-026	9545-008-026	1
27	Terminal Block, Channel Mount		9897-033-002	9897-033-002	9897-033-002	9897-033-002	1
*	Panel Assy., Back Before Serial #535659	9989-455-001	9989-455-001		9989-491-001		1
*	Panel Assy., Back After Serial #535659		9989-526-001	9989-526-001			1
*	Panel Assy., Back, Upper					9454-873-001	
*	Panel Assy., Back, Lower					9454-872-001	
*	Screw Panel Mtg.#10Bx1/2"	9545-008-026			9545-008-026	9545-008-026	10
*	Screw Panel Mtg.#10Bx1/2"		9545-008-026	9545-008-026			9
*	Screw Panel Mtg.#10Bx1/2"						13
*	Nut, Spring	8640-399-007	8640-399-007	8640-399-007	8640-399-007	8640-399-007	AR
28	Screw, To Base-1/4" x 3/4"	9545-030-002	9545-030-002	9545-030-002	9545-030-002	9545-030-002	3

Cylinder, Seals & Bearings Part # by Model

Key	Description	T-750	T-900	T-950	T-1200	T-1450	QTY
*	Bearings and Seal Kit	9732-219-007	9732-219-007	9732-219-007	9732-219-007	9732-219-009	1
*	Housing, Bearing- Assembly (items #2-#6)	9803-187-001	9803-187-001	9803-187-001	9803-187-001	9803-209-001	1
2	Housing, Bearing	9241-181-004	9241-181-004	9241-181-004	9241-181-004	9241-195-003	1
3	Bearing, Front (LARGE)	9036-159-006	9036-159-006	9036-159-006	9036-159-006	9036-162-002	1
4	Bearing, Rear (SMALL)	9036-159-005	9036-159-005	9036-159-005	9036-159-005	9036-162-001	1
5	Spacer, Bearing	9538-170-001	9538-170-001	9538-170-001	9538-170-001	9538-185-001	1
6	Ring, Bearing Retainer	9487-238-004	9487-238-004	9487-238-004	9487-238-004	9487-238-004	1
8	Seal, Small V85A	9532-140-007	9532-140-007	9532-140-007	9532-140-007		1
8	Seal, Small V95A					9532-140-012	
9	Seal, Large V140A	9532-140-008	9532-140-008	9532-140-008	9532-140-008	9532-140-008	1
10	Ring, Seal Mounting	9950-052-001	9950-052-001	9950-052-001	9950-052-001	9950-062-001	1
11	Tub Back Mating Ring	9950-052-001	9950-054-004	9950-054-004	9950-054-004	9487-261-005	1
11G	Mating Ring Guard Shield	9487-266-001		9487-266-001		9487-276-001	1
12	Bolt, Tub End of Bearing Housing (7/16-14x1), Bolt from inside Tub	9545-059-004	9545-059-004	9545-059-004	9545-059-004	9545-059-004	6
13	Washer, Flat	8641-581-034	8641-581-034	8641-581-034	8641-581-034	8641-581-034	6
14	Screw-Hex Cap, 3/4"-10 x 3" (Bearing Housing to Frame)	9545-057-002	9545-057-002	9545-057-002	9545-057-002		6
14	Screw-Hex Cap, 7/8"-10 x 3" (Bearing Housing to Frame)					9545-066-001	6
15	Washers Spherical 3/4 (Male half) (Bearing Housing to Frame)	8641-588-001		8641-588-001	8641-588-001		6
15	Washers Spherical 7/8 (Male half) (Bearing Housing to Frame)					8641-588-003	
16	Washers Spherical 3/4 (Female half) (Bearing Housing to Frame)	8641-588-002		8641-588-002	8641-588-002		6
16	Washers Spherical 7/8 (Female half) (Bearing Housing to Frame)					8641-588-004	6
15	Washer, Flat		8641-581-033				6
16	Lock Washer-External Tooth, 3/4" (Bearing Housing to Frame)		8641-582-020				6
17	Nut 3/4"-10 (Bearing Housing to Frame)	8640-418-003	8640-418-003	8640-418-003	8640-418-003		6
17	Nut 7/8"-9 (Bearing Housing to Frame)					8640-437-001	6
18	Pulley, Driven	9453-173-002	9453-176-005	9453-176-005	9453-176-005	9453-176-005	1
*	Tolerance Ring	9487-234-004					1
*	Screw, 5/8"-11 x 2"	9545-060-004					1
*	Washer-Flat, 5/8"	8641-582-032					1
*	Washer-Flat, 5/8"	8641-582-018					1
19	Bolt, 3/8"-16 x 2"		9545-029-011	9545-029-011	9545-029-011	9545-029-011	3
20	Washer, 3/8"		8641-582-003	8641-582-003	8641-582-003	8641-582-003	3
21	Bushing Taperlock (Driven & Large)		9053-078-002	9053-078-002	9053-078-002	9053-078-002	1
22	Washer-Flat .675x2-1/2x1/4	8641-581-043	8641-581-043	8641-581-043	8641-581-043		1
23	Lockwasher-Exttooth, 5/8	8641-582-018	8641-582-018	8641-582-018	8641-582-018		1
24	Bolt, 5/8-11x1 1/2	9545-060-001	9545-060-001	9545-060-001	9545-060-001		1
22	Washer-Flat, .781x2-1/2x1/4					8641-581-044	1
23	Lockwasher-Exttooth, 3/4					8641-582-020	1
24	Bolt, 3/4-10-1 1/2					9545-057-004	1
25	Tub & Cylinder Assy Before Serial #535659	9869-025-002	9869-023-002		9869-022-002		1
25	Tub & Cylinder Assy After Serial #535659		9869-027-002	9869-027-002		9869-026-001	1
*	Cylinder Assy	9848-136-002	9848-136-001	9848-136-001	9848-137-001	9848-141-001	1

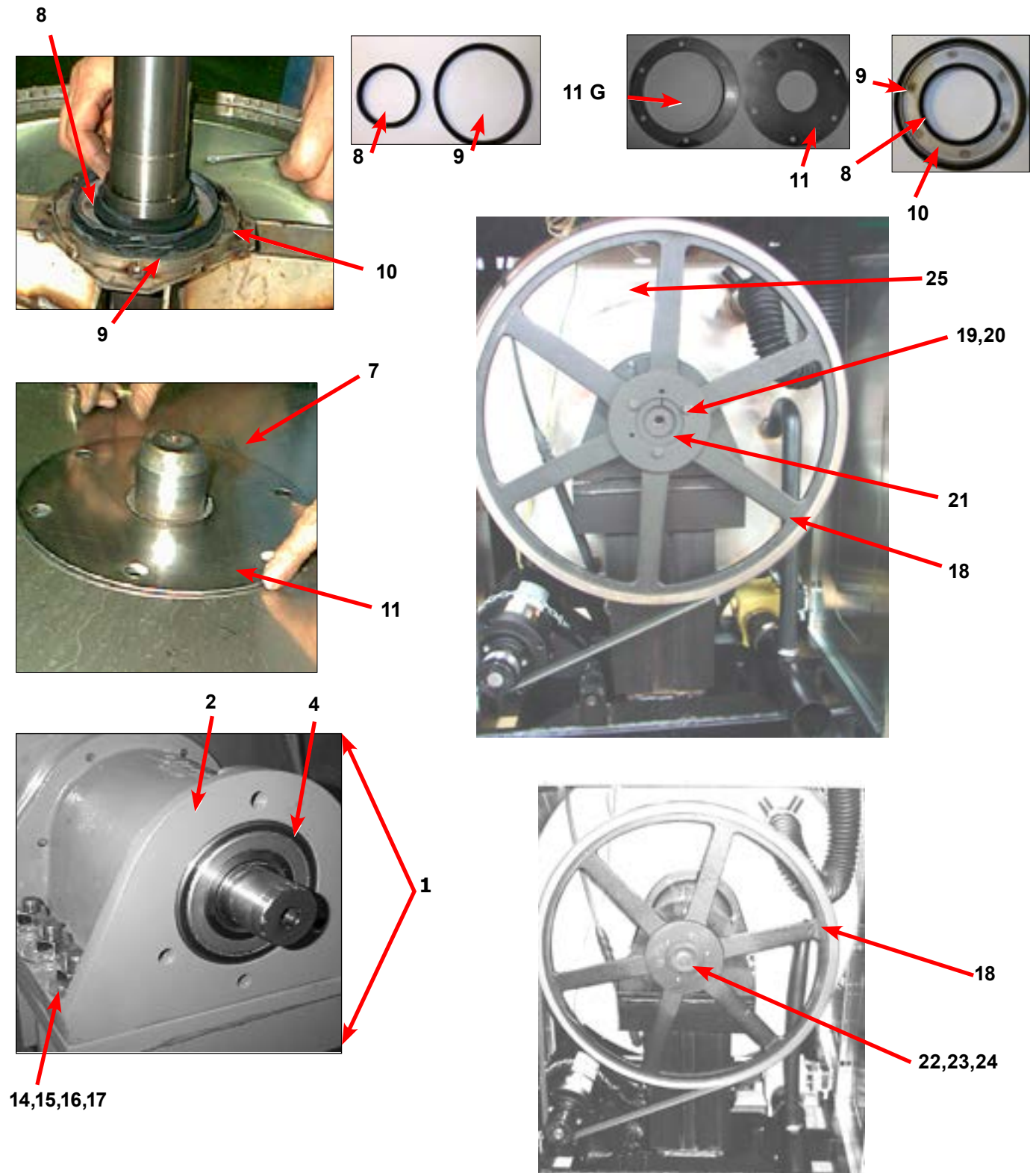

Key	Description	T750	T-900	T950	T-1200	T1450	QTY
*	Tub Front Before Serial #535659	9974-011-002	9178-148-001		9974-011-002		1
*	Tub Front After Serial #535659		9974-011-002	9974-011-002		9178-056-001	1
*	Gasket, Tub Front		9206-421-002	9206-421-002	9206-421-002	9206-421-003	1
*	Ring Assy, Tub Mtg-Front Clamp	9950-055-001	9950-055-001	9950-055-001	9950-055-001	9950-061-001	1
*	Bolt, Top Front Ring 3/8"-16 x 3"	9545-029-009	9545-029-009	9545-029-009	9545-029-009	9545-029-009	1
*	Nut WCAD 3/8"-16	8640-415-001	8640-415-001	8640-415-001	8640-415-001	8640-415-001	1

Door Latching Assembly (All Models)

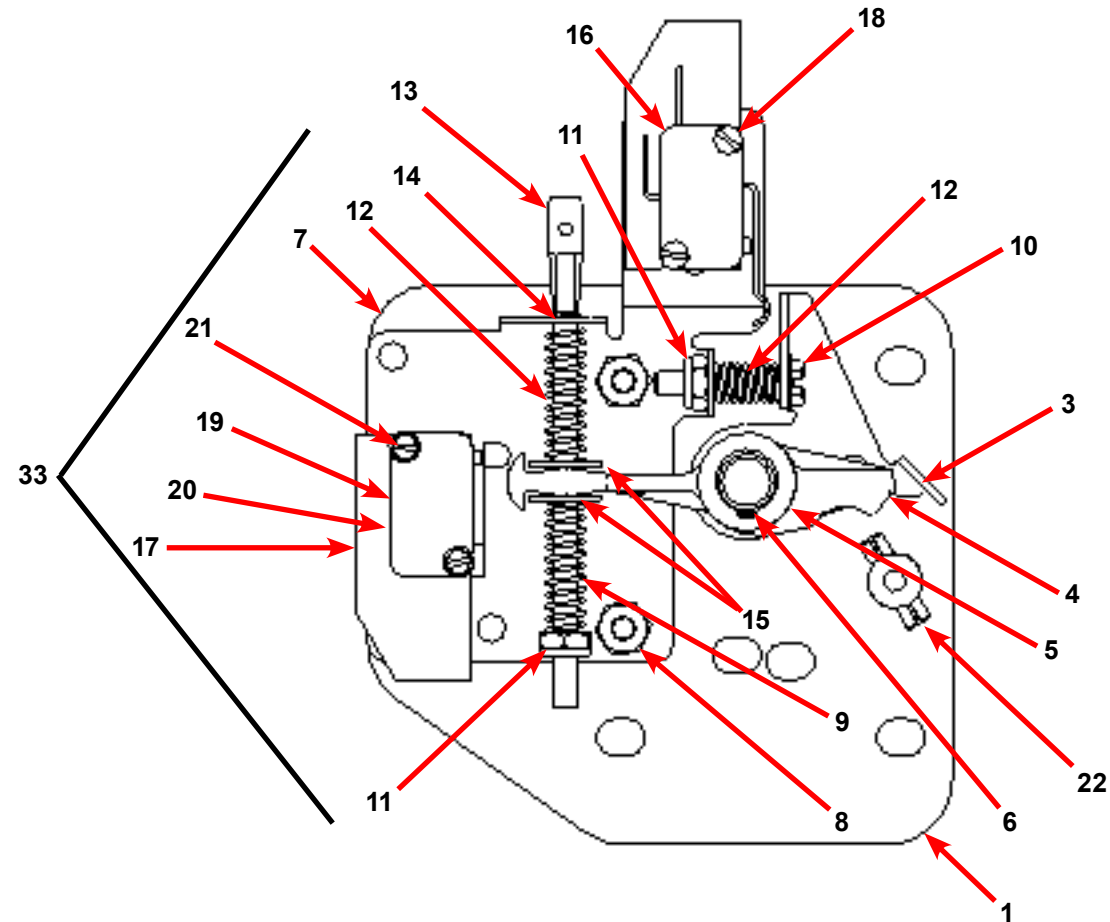

Key	Description	All Models	QTY
33	Latching Assy, Complete (includes #1 thru #22)	9885-024-001	1
1	Plate Assy, Door Lock	9982-346-001	1
2	Washer, Flat (SS or Brass)	8641-581-030	1
3	Actuator, Latching Switch	9008-005-001	1
4	Pawl, Locking	9732-346-002	1
5	Washer, Spring	8641-569-003	1
6	Ring, Retaining	9487-200-004	1
7	Bracket Switch	9029-163-001	1
8	Nut, Hex 10-32 UNF	8640-413-002	2
9	Spring, Actuating	9534-364-002	1
10	Screw, Hx. 10-32 x 1"	9545-012-020	1
11	Nut, Elastic Stop 10-32	8640-413-004	2
12	Spring, Return	9534-364-001	2
13	Pin, Guide	9451-193-001	1

Key	Description	All Models	QTY
14	Ring, Retaining	9487-200-005	1
15	Washer	8641-581-031	1
16	Switch, Latching Sensing	9539-461-008	1
17	Shield, Switch	9550-169-003	3
18	Screw 4-40 x 5/8"	9545-020-001	2
18	Nut, Twin 4-40	8640-401-001	1
19	Switch, Locking Sensing	9539-461-007	2
20	Actuator, Switch Locking	9008-006-003	1
21	Screw 4-40 x 1 1/8"	9545-020-003	2
21	Nut, Twin 4-40	8640-401-001	1
22	Spacer Sensor	9538-182-001	1
23	Pin, Dowel	9451-181-004	1
*	Shim, Door Lock, Thin	9552-037-001	AR
*	Screw, Lock mtg 1/4"-20 x 3/4"	9545-018-014	3
*	Lockwasher 1/4" Ext tooth	8641-582-007	3
*	Door Stud Pin, 3/16" x 3/4"	9451-181-004	1

Gear Motor Door Lock Assembly

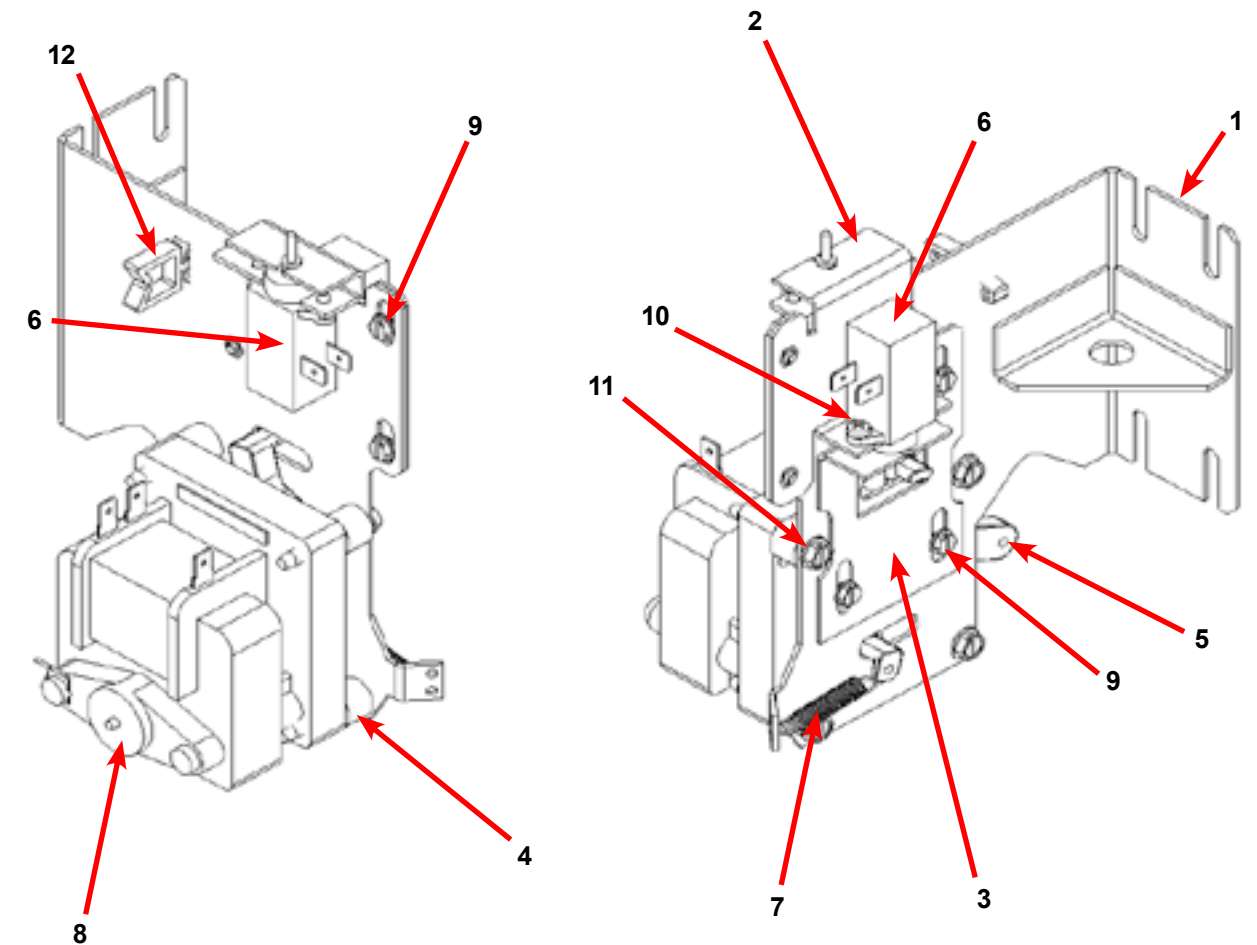

Key	Description	T-750	T-900	T-950	T-1200	T-1450	QTY
*	Actuator Assembly (Includes 1-10, Rod NOT included)	9892-015-001	9892-015-001	9892-015-001	9892-015-001	9892-015-001	1
11	Screw-hxwshdsl, 10-24-1.25f, ctd	9545-046-007	9545-046-007	9545-046-007	9545-046-007	9545-046-007	4
10	Cross Recessed PAn Hd Tapping screw	9545-031-011	9545-031-011	9545-031-011	9545-031-011	9545-031-011	4
9	Screw -Hxwshrhdslsems, 6-32 x 3/16	9545-044-003	9545-044-003	9545-044-003	9545-044-003	9545-044-003	6
8	Motor & Gear Assembly 120v	9914-137-011	9914-137-011	9914-137-011	9914-137-011	9914-137-011	1
7	Spring - Extension	9534-350-001	9534-350-001	9534-350-001	9534-350-001	9534-350-001	1
6	Thermoactuator - Door Lock Relay 120v	9586-001-001	9586-001-001	9586-001-001	9586-001-001	9586-001-001	2
5	Arm - Door Lock	9001-063-001	9001-063-001	9001-063-001	9001-063-001	9001-063-001	1
4	Spacer, Plastic	9538-157-021	9538-157-021	9538-157-021	9538-157-021	9538-157-021	4
3	Bracket Slide Lock	9029-204-001	9029-204-001	9029-204-001	9029-204-001	9029-204-001	1
2	Bracket Assy, Slide - Unlock	9985-189-001	9985-189-001	9985-189-001	9985-189-001	9985-189-001	1
1	Bracket Assy, Slide Lock Actuator	9985-190-001	9985-190-001	9985-190-001	9985-190-001	9985-190-001	1
*	Rod, Door Lock Before Serial #535659	9497-225-013	9497-225-013				1
*	Rod, Door Lock After Serial #535659		9497-225-015	9497-225-015	9497-225-015	9497-225-016	1
*	Spacer, Gear Motor	9538-187-001	9538-187-001	9538-187-001	9538-187-001	9538-187-001	1

Original Door Lock Solenoid Assembly

Key	Description	T-750	T-900	T-950	T-1200	T-1450	QTY
1	Solenoid Ass'y, Door Locking (includes 23 thru 32)	9922-011-001	9922-011-001		9922-011-001		1
2	Bracket, (Door Locking Solenoid)	9029-073-001	9029-073-001		9029-073-001		1
3	Bracket Ass'y, Solenoid Slide	9985-169-001	9985-169-001		9985-169-001		1
4	Solenoid 120V 60 hz	9536-074-001	9536-074-001		9536-074-001		1
5	Screw, Solenoid Mtg	9545-008-001	9545-008-001		9545-008-001		4
6	Stop, Door Lock Solenoid	9540-033-002	9540-036-001		9540-033-002		1
7	Screw, Shoulder	9545-061-001					1
*	Nut, Keps #6	8640-411-002	8640-411-002		8640-411-002		1
9	Thermoactuator 120 V	9586-001-001	9586-001-001		9586-001-001		2
10	Screw #6 x 5/16"	9545-031-011	9545-031-011		9545-031-011		4
11	Spacer, Plastic	9538-157-004	9538-157-004		9538-157-004		1
12	Spacer, Metal	9538-166-004	9538-166-004		9538-166-004		1
13	Screw, Cross Recessed	9545-010-001	9545-010-001		9545-010-001		1
14	Nut, Keps #8	8640-412-005	8640-412-005		8640-412-005		1
*	Nut, Sol. Brkt. to Control Panel	8640-412-005	8640-412-005		8640-412-005		3
*	Rod, Pull	9497-225-007	9497-225-007		9497-225-009		1

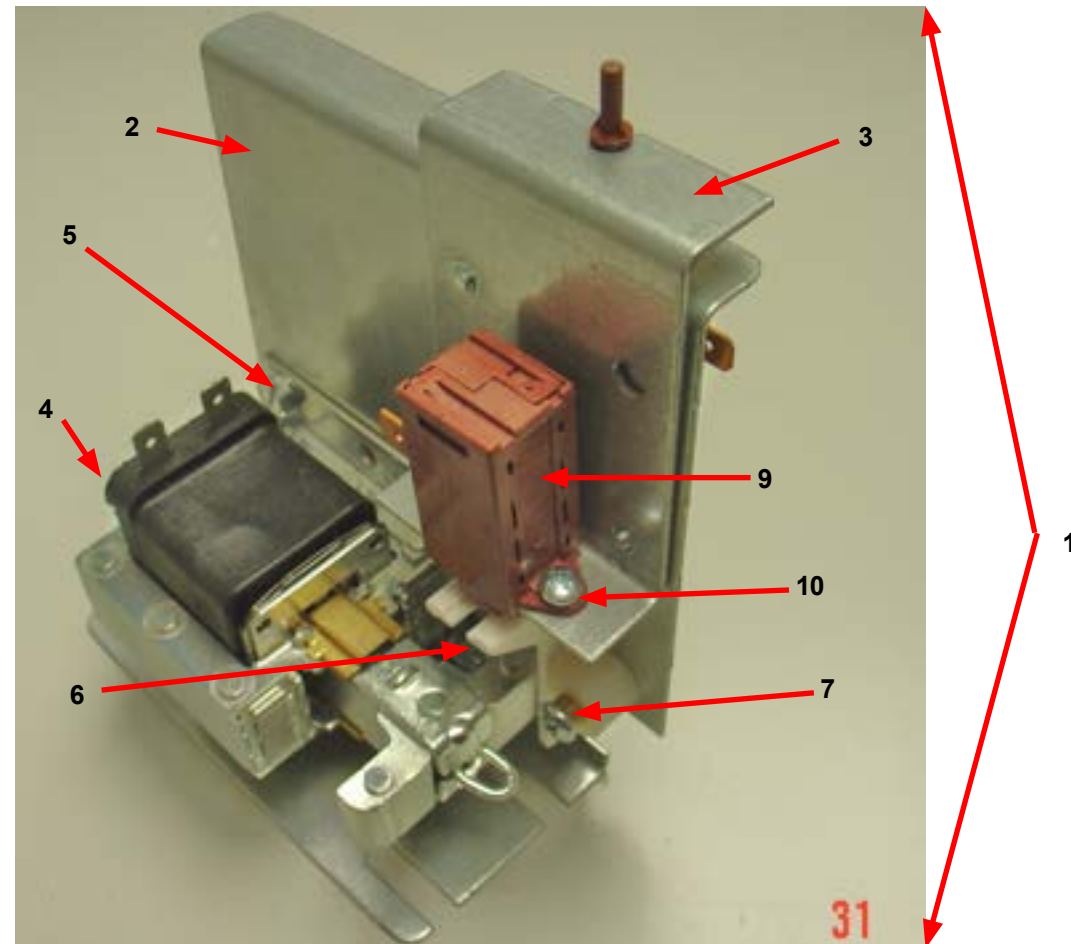

Original Door Lock Solenoid Assembly

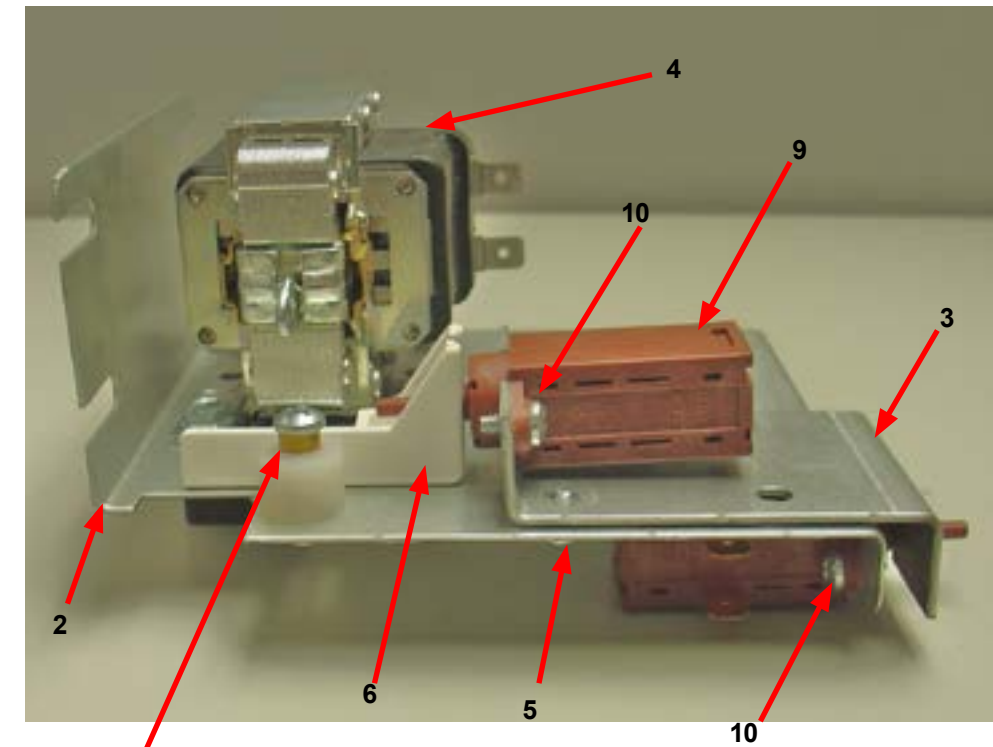

Large Door & Hinge Group (After #514975)

Key	Description	T-750	T-900	T-950	T-1200	T-1450	QTY
1	Door Hinge Assembly (mounts to tub front)	9955-031-001	9955-031-001	9955-031-001	9955-031-001	9955-031-001	1
*	Door Assembly Complete	9960-274-005	9960-274-005	9960-274-005	9960-274-005	9960-274-005	1
2	Door Ring 180 degree large hinge	9487-275-001	9487-275-001	9487-275-001	9487-275-001	9487-275-001	1
3	Door Gasket	9206-431-001	9206-431-001	9206-431-001	9206-431-001	9206-431-001	1
4	Door Glass Window	9635-020-001	9635-020-001	9635-020-001	9635-020-001	9635-020-001	1
*	Red Wire (Door Close Switch)	8220-063-028	8220-063-028	8220-063-028	8220-063-028	8220-063-028	1
	Black Wire (Door Close Switch)	8220-063-029	8220-063-029	8220-063-029	8220-063-029	8220-063-029	1
5	Switch, Door Hinge Close (Plunger)	9539-492-001	9539-492-001	9539-492-001	9539-492-001	9539-492-001	1
6	Top Door Hinge Leaf (No pin)	9845-006-001	9845-006-001	9845-006-001	9845-006-001	9845-006-001	1
7	Bottom Door Hinge Leaf	9845-007-001	9845-007-001	9845-007-001	9845-007-001	9845-007-001	1
8	Thrd Form Screw, Door Mtg 5/16" x 5/8"	9545-056-002	9545-056-002	9545-056-002	9545-056-002	9545-056-002	4
9	Screw, Loading Door Hinge Mtg (5/16" x 9/16" ss)	9545-014-013	9545-014-013	9545-014-013	9545-014-013	9545-014-013	3
10	Bracket Retainer support side panel	9046-085-001	9046-085-001	9046-085-001	9046-085-001	9046-085-001	1
*	Shim Large door	9552-043-001	9552-043-001	9552-043-001	9552-043-001	9552-043-001	1

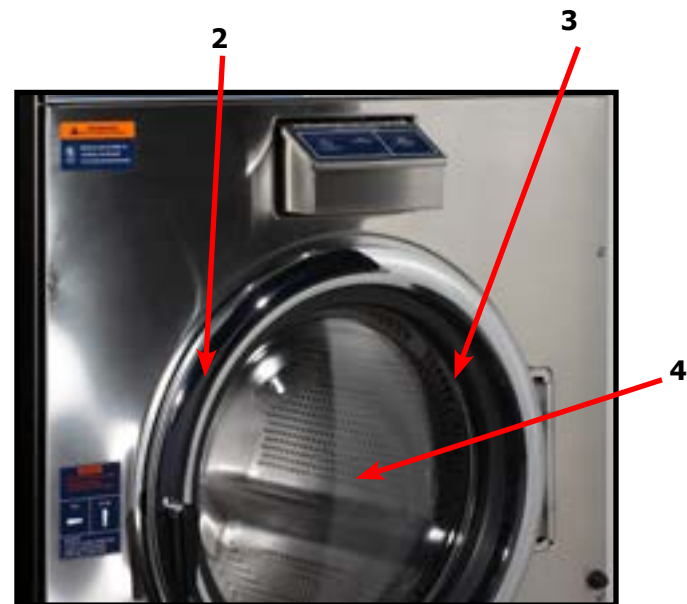

Key	Description	T750	T-900	T950	T-1200	T1450	QTY
11	Shaft, Door Locking	9537-195-002	9537-195-002	9537-195-002	9537-195-002	9537-195-002	1
12	Cam, Locking	9095-040-002	9095-040-002	9095-040-002	9095-040-002	9095-040-002	1
13	Pin, Groove (1 1/4)	9451-181-005	9451-181-005	9451-181-005	9451-181-005	9451-181-005	1
14	Pin, Groove (3/4)	9451-181-004	9451-181-004	9451-181-004	9451-181-004	9451-181-004	1
15	Spring, Lock Cam	9534-360-002	9534-360-002	9534-360-002	9534-360-002	9534-360-002	1
16	Handle, Door	9244-080-003	9244-080-003	9244-080-003	9244-080-003	9244-080-003	1
17	Pin, Door Handle (groove)	9451-181-006	9451-181-006	9451-181-006	9451-181-006	9451-181-006	1

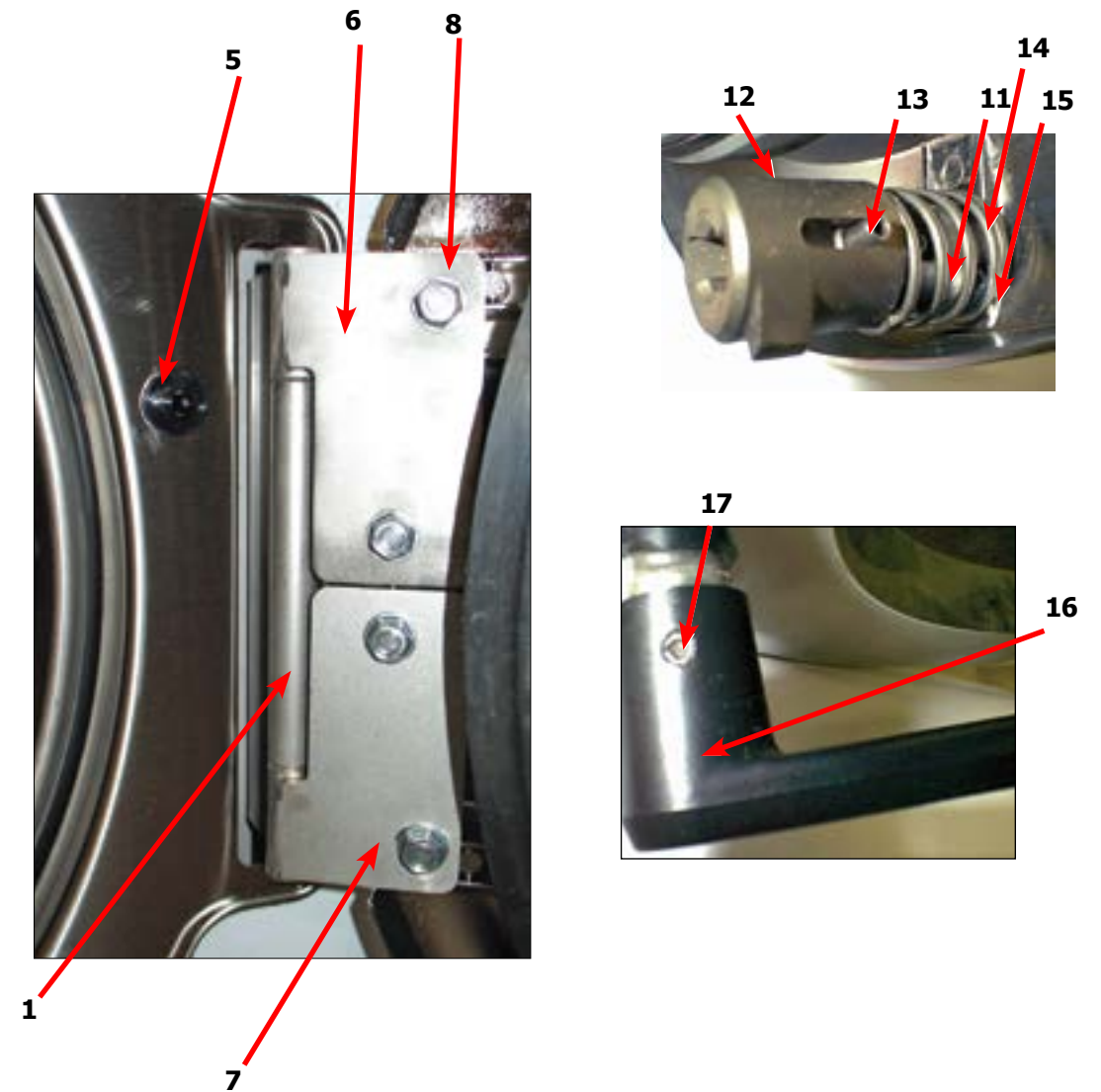

WCAD75 180-Degree Door & Hinge Group

(Before #514975)

Key	Part Number	Description.....	Qty
*	9960-274-004	Loading Door, Complete (includes #1thru #10)	1
1	9487-265-002	Loading Door Ring 180 degree.....	1
2	9206-419-001	Gasket, Loading Door.....	1
3	9635-016-001	Window, Loading Door.....	1
4	9913-134-003	Shaft Assy. Locking (includes #5 thru #8).....	1
5	9537-195-002	Shaft, Door Locking.....	1
6	9095-040-001	Cam, Locking.....	1
7	9451-181-005	Pin, Groove (1 1/4).....	1
8	9451-181-005	Pin, Groove (3/4).....	1
9	9534-360-002	Spring, Lock Cam.....	1
10	9244-080-003	Handle, Door.....	1
17	9451-181-006	Roll Pin, Door Handle (groove).....	1
11	9955-030-001	Hinge Assy, Loading Door (mounts to tub front).....	1
*	9545-014-009	Screw, Hinge Mtg.....	3
*	8641-582-009	Lockwasher.....	3
*	9552-036-001	Shim, Loading Door Hinge, Thin.....	AR
*	9552-036-002	Shim, Loading Door Hinge, Thick.....	AR
12	9845-005-003	Top, Loading Door Leaf Hinge with pin.....	1
13	9845-005-002	Bottom, Loading Door Leaf Hinge.....	1
16	9545-056-002	Screw, Loading Door Hinge Mtg.....	3
15	9950-060-002	Ring, Masking w door switch hole.....	1
*	8640-413-002	Nut.....	4
*	9059-063-002	Band Edge Protector.....	1
*	9801-089-001	Door Closure Switch Assembly.....	1
D1	9041-087-001	Switch Box.....	1
*	9053-067-003	Bushing Insulating.....	1
D3	9539-461-007	Switch, Micro.....	1
D2	9550-159-001	Switch, Shield.....	1
D4	8640-401-001	Nut Special Twin #4-40.....	1
D8	9545-020-001	Screw 4-40x5/8.....	2
D7	9008-004-001	Door Switch Actuator.....	1

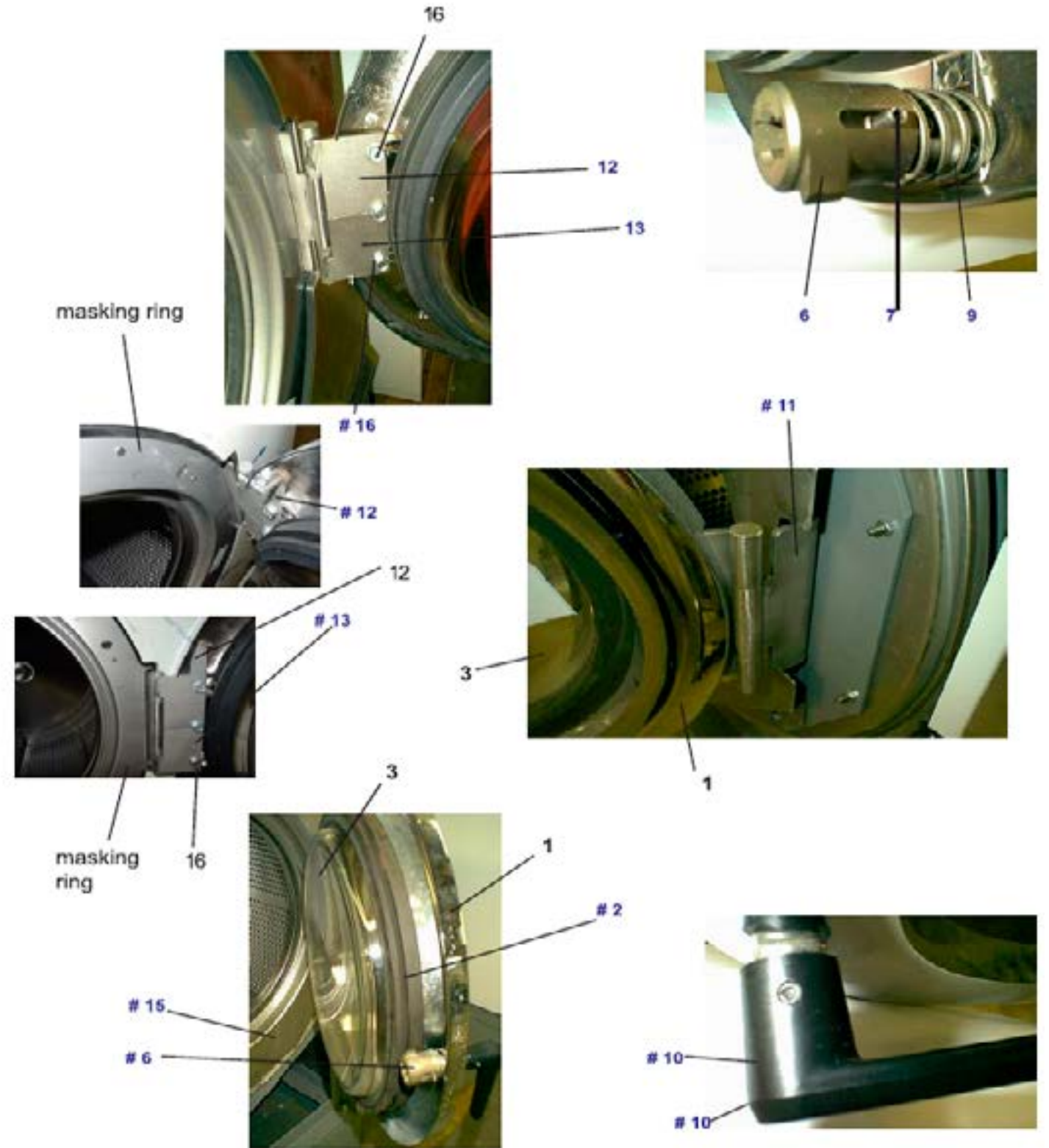
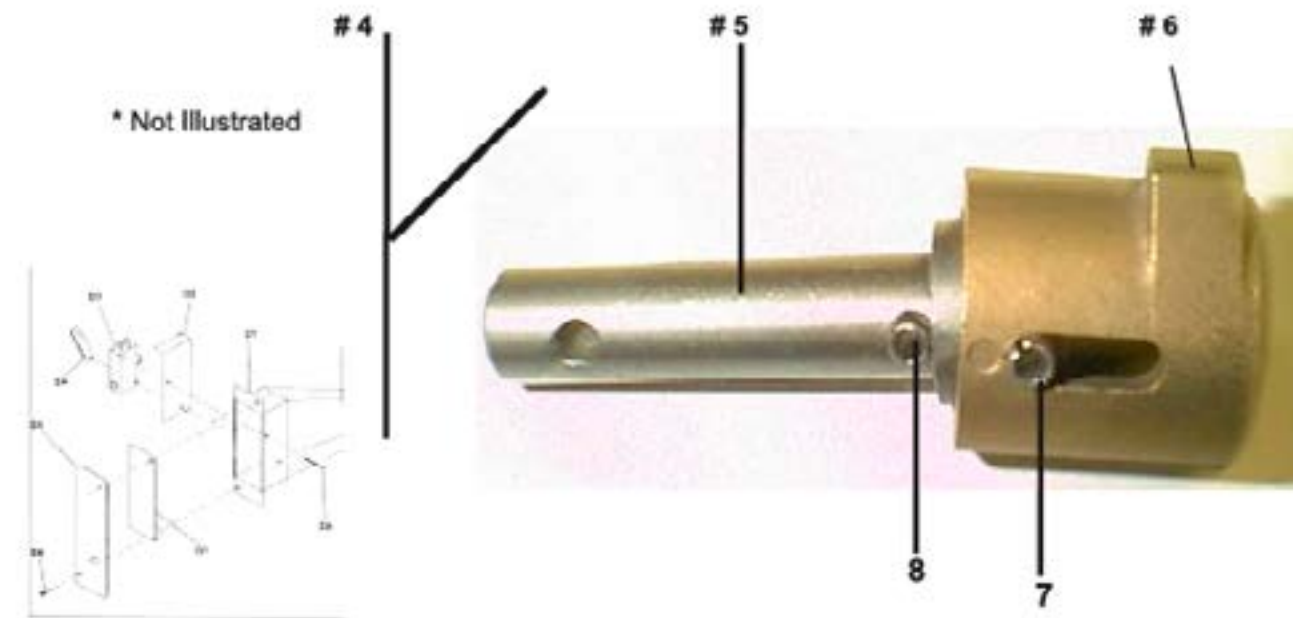

Door & Hinge Group

(Before #514975)

Key	Part Number	Description.....	Qty
*	9960-274-002	Loading Door, Complete (includes #1thru #10)	1
1	9487-265-001	Loading Door Ring.....	1
2	9206-419-001	Gasket, Loading Door.....	1
3	9635-016-001	Window, Loading Door.....	1
4	9913-134-003	Shaft Assy. Locking (includes #5 thru #8).....	1
*	9537-195-002	Shaft, Door Locking.....	1
5	9095-040-001	Cam, Locking.....	1
6	9451-181-005	Pin, Groove (1 1/4).....	1
7	9451-181-005	Pin, Groove (3/4).....	1
8	9534-360-002	Spring, Lock Cam.....	1
9	9244-080-003	Handle, Door.....	1
*	9451-181-006	Roll Pin, Door Handle (groove).....	1
10	9955-029-002	Hinge Assy, Loading Door (mounts to tub front).....	1
*	9545-014-009	Screw, Hinge Mtg.....	3
*	8641-582-009	Lockwasher.....	3
*	9552-036-001	Shim, Loading Door Hinge, Thin.....	AR
12	9938-040-002	Hinge Clamp assembly w/ pin.....	1
13	9545-056-003	Screw, Loading Door Hinge Mtg.....	3
14	9950-060-001	Ring, Masking w door switch hole.....	1
*	8640-413-002	Nut.....	4
*	9059-063-002	Band Edge Protector.....	1
*	9801-089-001	Door Closure Switch Assembly.....	1
D1	9041-087-001	Switch Box.....	1
*	9053-067-002	Bushing Insulating.....	1
D3	9539-461-007	Switch, Micro.....	1
D2	9550-159-001	Switch, Shield.....	1
D4	8640-401-001	Nut Special Twin #4-40.....	1
D8	9545-020-001	Screw 4-40x5/8.....	2
D7	9008-004-001	Door Switch Actuator.....	1

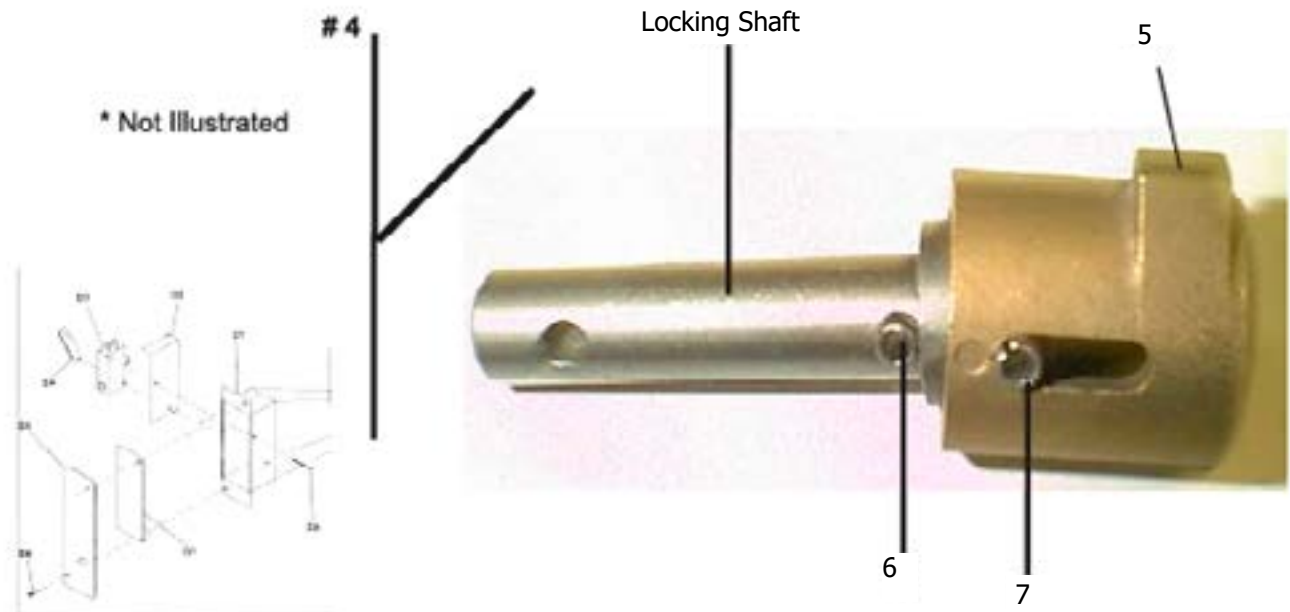
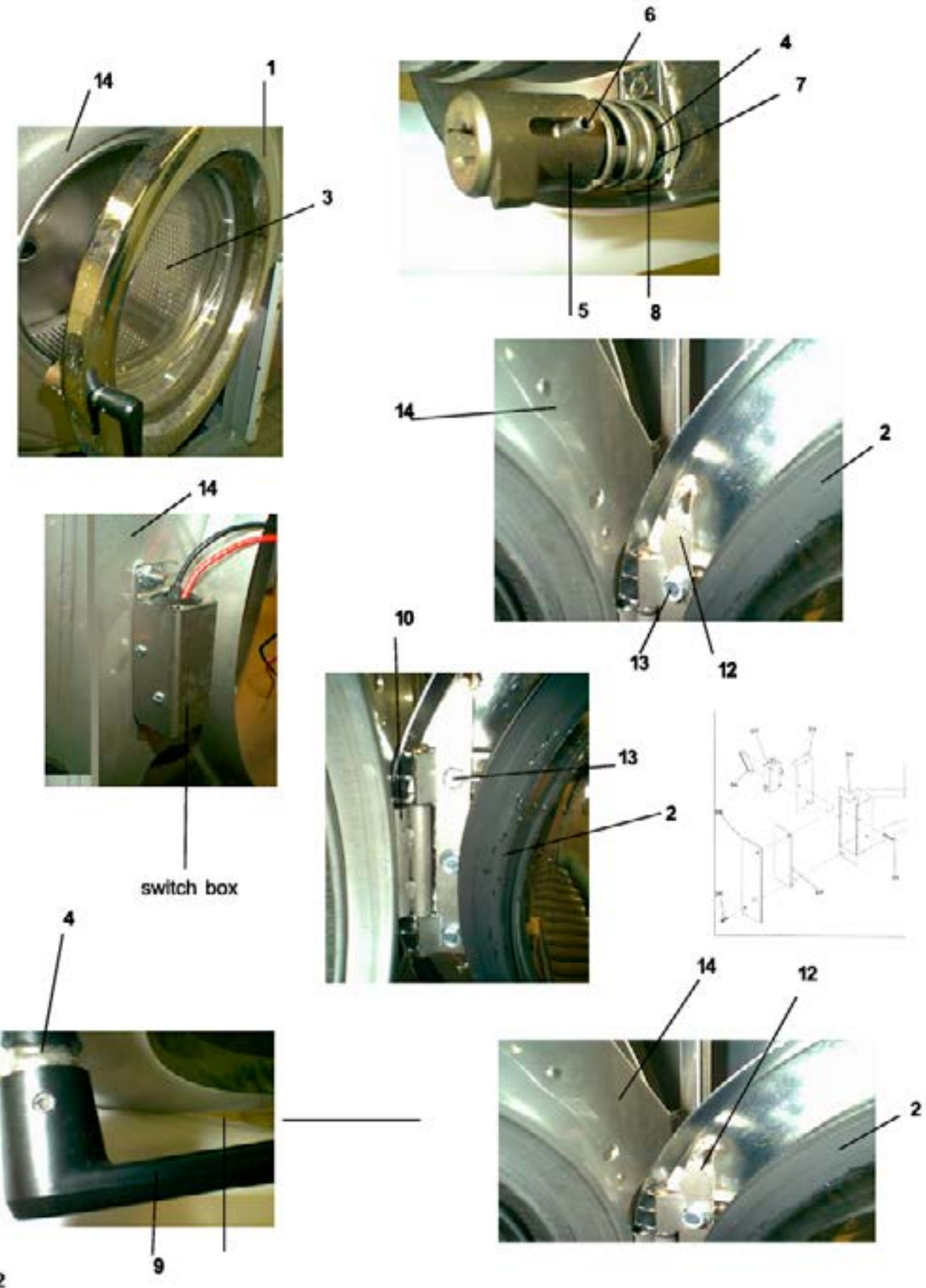

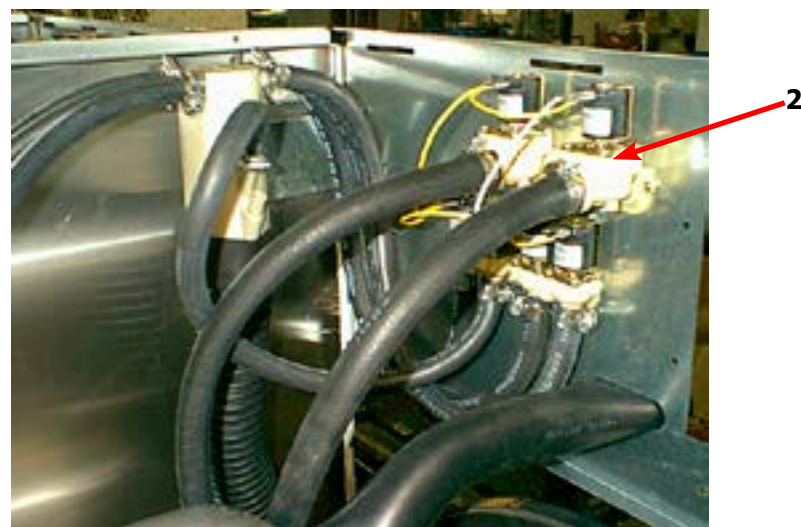
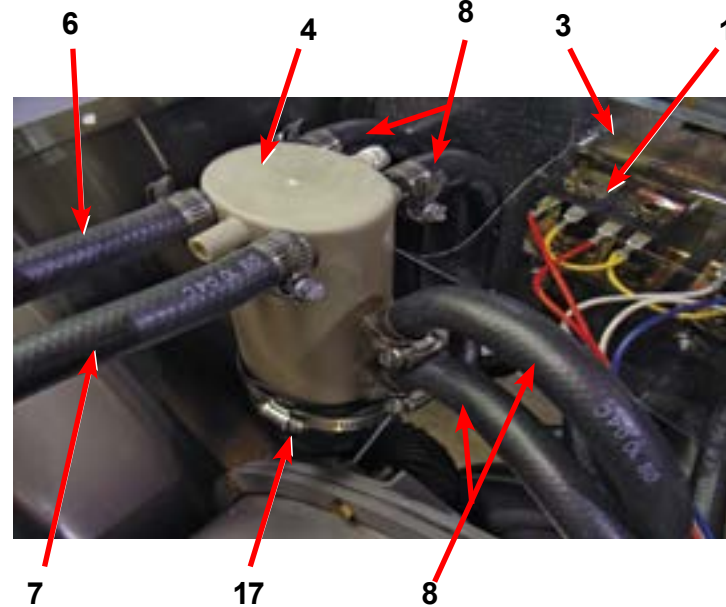
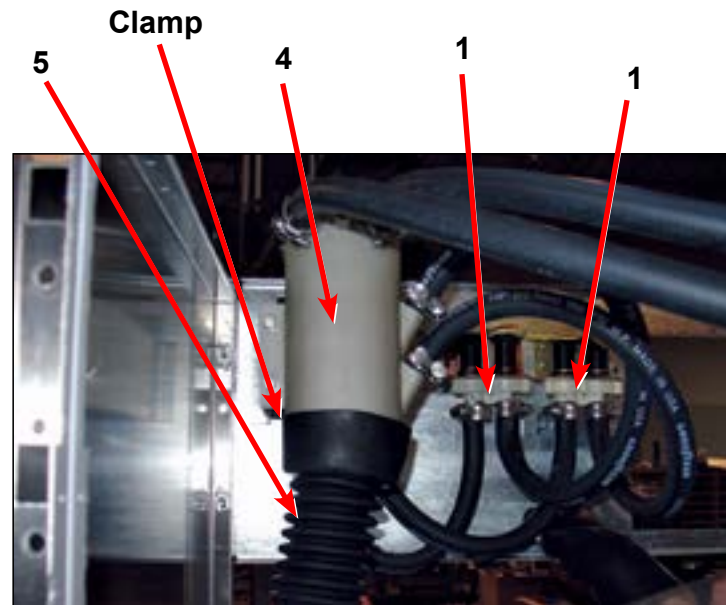

Water Inlet Part # by Model

Key	Description	T 750	T-900	T-950	T-1200	T-1450	QTY
1	Valve, Water Inlet (dual outlet) (see Water Inlet Valve Break-down for individual parts)	9379-183-012	9379-183-012	9379-183-012	9379-183-012	9379-183-012	2
2	Valve Water Inlet (single outlet)			9379-194-001	9379-194-001	9379-194-001	2
*	Screw, Valve Mtg	9545-008-026	9545-008-026	9545-008-026	9545-008-026	9545-008-026	4
*	Screw, Valve M4x0.7x8mm			9495-064-001	9545-064-001	9545-064-001	8
3	Guard Water Valve Terminal		9208-049-001	9208-049-001	9208-049-001	9208-049-001	1
4	Vacuum Breaker	9610-001-001	9610-001-001	9610-001-001	9610-001-001	9610-001-001	1
*	Vacuum Breaker Cap (Red)		0935-135-002	0935-135-002	0935-135-002	0935-135-002	*
*	Bracket, Vacuum Breaker	9029-069-001	9029-069-001	9029-069-001	9029-069-001	9029-069-002	1
*	Screw	9545-008-026	9545-008-026	9545-008-026	9545-008-026	9545-008-026	4
*	Shield over Water Valves Plastic	9550-186-001	9550-186-001	9550-186-001	9550-186-001	9550-186-001	1
	Screw 10-32x3/4" for shield	9545-012-006	9545-012-006	9545-012-006	9545-012-006	9545-012-006	2
*	Nut #10-32	8640-413-004	8640-413-004	8640-413-004	8640-413-004	8640-413-004	2
5	Hose, Vacuum Breaker to Tub	9242-458-003	9242-458-003	9242-458-003	9242-458-003	9242-458-003	1
*	Clamp, Tub End;Vac Brkr	8654-117-014	8654-117-014	8654-117-014	8654-117-014	8654-117-014	1
6	Hose, Vac. Brkr. to Disp.	9242-453-009	9242-453-018	9242-453-018			1
7	Hose, Vac. Brkr. to Disp.	9242-453-006	9242-453-019	9242-453-019			1
9	Hose, Hot Valve to Tub		9242-453-020	9242-453-020	9242-466-002	9242-466-002	1
11	Hose, Cold Valve to Tub		9242-453-020	9242-453-020	9242-466-002	9242-466-002	1
12	Hose, Vac. Brkr. dispenser				9242-453-022	9242-453-023	3
13	Hose, (valve to vac. Brkr)	9242-453-020			9242-453-009	9242-453-009	4
*	Clamp, Hose-Spring (overflow from drain to tub back)	8654-117-018	8654-117-018	8654-117-018	8654-117-018	8654-117-018	2
	Hose, (valve to Tub Inlet)			9242-466-002	9242-466-002	9242-466-002	2
*	Clamp, Hose-Worm		8654-117-015	8654-117-015	8654-117-015	8654-117-015	1
*	Flow restrictor	9475-002-002	9475-002-002	9475-002-002	9475-002-002	9475-002-002	2
*	Flow restrictor		9475-002-002	9475-002-002	9475-002-003	9475-002-003	3
*	Circuit Breaker (optional)	5198-211-004	5198-211-004	5198-211-004			1
14	Fuseholder	9200-001-002	9200-001-002	9200-001-002	9200-001-002	9200-001-002	1
15	Fuse 1.5 amp	8636-018-001	8636-018-001	8636-018-001			1
15	Fuse 2.5 amp				8636-018-004	8636-018-004	1
17	Clamp, Vacuum Breaker End	8654-117-014	8654-117-014	8654-117-014	8654-117-014	8654-117-014	1
	Vacuum Breaker Cap		0935-135-002				2
	Hose Assembly Inlet	9990-027-013	9990-027-013				2

14 & 15



Water Inlet Valve Breakdown Part # by Model

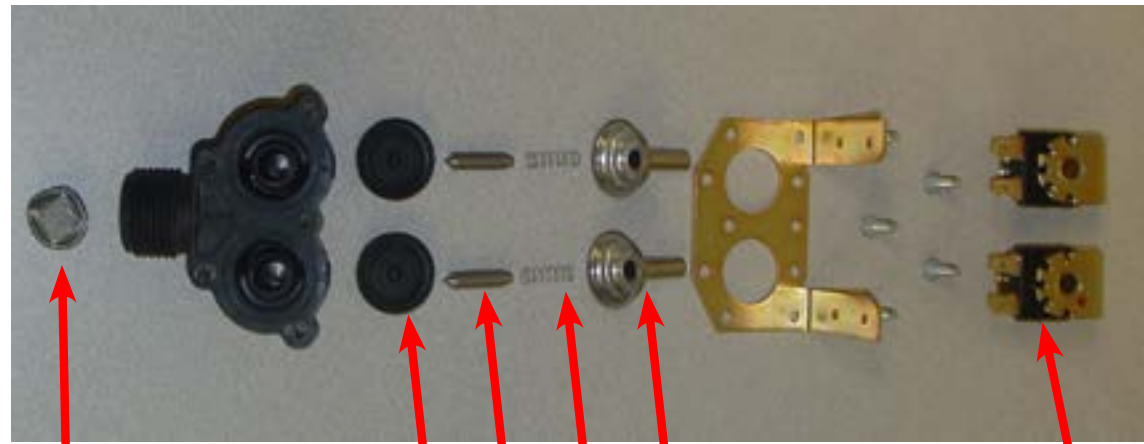

Key	Description	T-750	T-900	T-950	T-1200	T-1450	QTY
*	Valve, Water Inlet (includes 1 thru 6) - Invensys	9379-183-012	9379-183-012	9379-183-012	9379-183-012	9379-183-012	2
1	Screen, Inlet end of valve	9555-056-001	9555-056-001	9555-056-001	9555-056-001	9555-056-001	2
2	Coil Assy, 120 V Invensys	9089-017-001	9089-017-001	9089-017-001	9089-017-001	9089-017-001	2
3	Diaphragm Invensys (EPDM NSF)	9118-049-003	9118-049-003	9118-049-003	9118-049-003	9118-049-003	2
4	Guide, Solenoid Invensys	9211-021-002	9211-021-002	9211-021-002	9211-021-002	9211-021-002	2
5	Armature Invensys	9015-008-001	9015-008-001	9015-008-001	9015-008-001	9015-008-001	2
6	Spring, Armature Invensys	9534-298-001	9534-298-001	9534-298-001	9534-298-001	9534-298-001	2
*	Optional Diaphran (Viaton)	9118-049-002	9118-049-002	9118-049-002	9118-049-002	9118-049-002	2
*	Wiring Harness	9794-001-001			9794-001-001		1

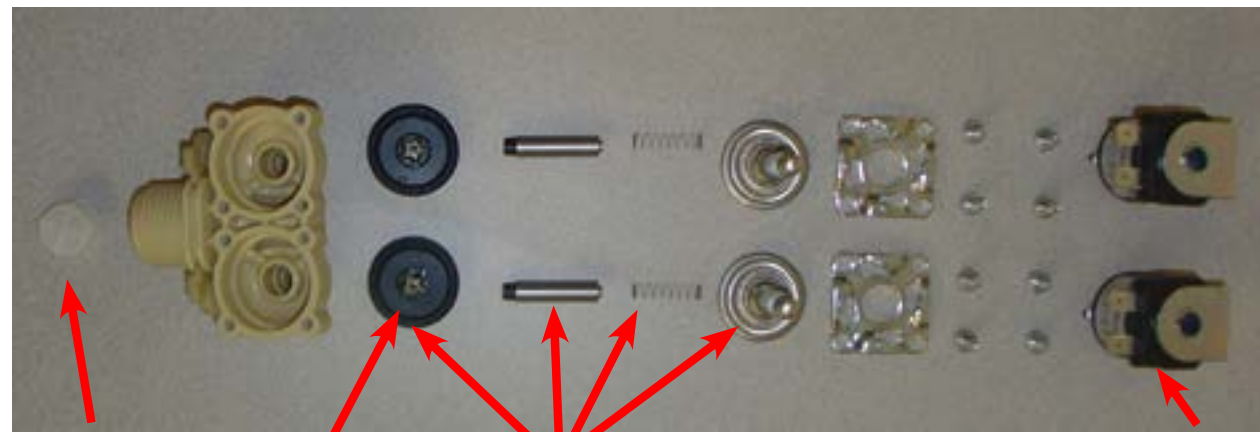

Optional Water Valve

Key	Description	T-750	T-900	T-950	T-1200	T-1450	QTY
*	Dual Coil Water Valve Mueller	9379-192-001	9379-192-001	9379-192-001	9379-192-001	9379-192-001	1
7	Valve Water Body Complete(no coil)	9379-192-002	9379-192-002	9379-192-002	9379-192-002	9379-192-002	1
8	Diaphragm Mueller	9118-054-001	9118-054-001	9118-054-001	9118-054-001	9118-054-001	2
9	Filter Mueller	9183-046-001	9183-046-001	9183-046-001	9183-046-001	9183-046-001	2
10	Coil Mueller	9089-051-001	9089-051-001	9089-051-001	9089-051-001	9089-051-001	2
11	Diaphragm Assembly Mueller Includes	9785-001-001	9785-001-001	9785-001-001	9785-001-001	9785-001-001	2

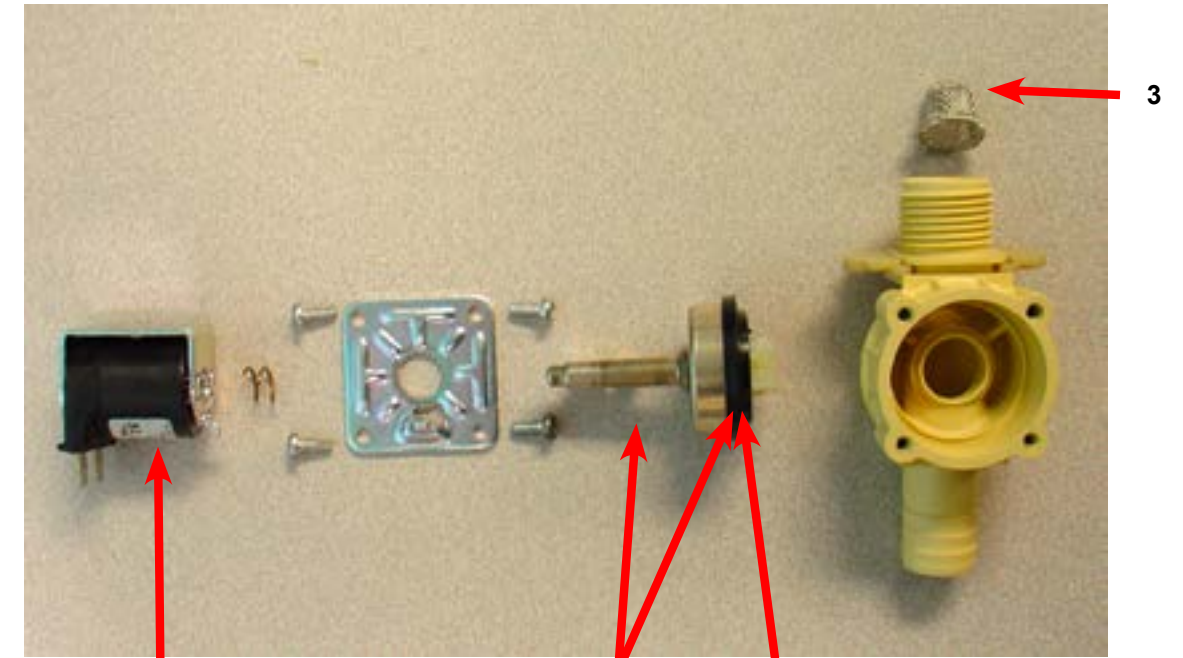

Key	Description	T-750	T-900	T-950	T-1200	T-1450	QTY
*	Single Coil Water Valve Mueller				9379-194-001	9379-194-001	1
1	Valve Water Body Complete (no coil)				9379-194-002	9379-194-002	1
2	Diaphragm Mueller				9118-055-001	9118-055-001	1
3	Filter Mueller				9183-046-001	9183-046-001	1
4	Coil Mueller				9089-051-001	9089-051-001	1
5	Diaphragm Assembly Mueller				9785-002-001	9785-002-001	1

Notes

Drain Valve Group Part # by Model

Key	Description	T-750	T-900	T-950	T-1200	T-1450	QTY
1	Valve, Drain (includes #2 thru #11)	9379-202-001	9379-202-001	9379-202-001	9379-202-001	9379-202-001	1
2	Body, Valve (w/ball)	9064-070-001	9064-070-001	9064-070-001	9064-070-001	9064-070-001	1
3	Motor & Gear Train (complete)	9914-137-011	9914-137-011	9914-137-011	9914-137-011	9914-137-011	1
4	Plate, Motor Mtg	9452-538-001	9452-538-001	9452-538-001	9452-538-001	9452-538-001	1
5	Screw	8639-994-001	8639-994-001	8639-994-001	8639-994-001	8639-994-001	3
6	Spring, Drive	9534-339-001	9534-339-001	9534-339-001	9534-339-001	9534-339-001	1
7	Screw	9545-054-001	9545-054-001	9545-054-001	9545-054-001	9545-054-001	2
8	Screw	9545-054-002	9545-054-002	9545-054-002	9545-054-002	9545-054-002	1
9	Seal, V Packer	9532-134-001	9532-134-001	9532-134-001	9532-134-001	9532-134-001	2
10	Washer	8641-584-001	8641-584-001	8641-584-001	8641-584-001	8641-584-001	1
11	Pin, Main Drive	9451-196-001	9451-196-001	9451-196-001	9451-196-001	9451-196-001	1
*	Plate (spacers needed for replacement motor mtg. plate)	9538-149-001	9451-196-001	9451-196-001	9538-149-001	9451-196-001	4
13	Stator and Coil Assembly	9089-036-004	9089-036-004	9089-036-004	9089-036-004	9089-036-004	1
*	Valve Drain before Serial # 482181	9379-187-001	9379-187-001	9379-187-001	9379-187-001	9379-187-001	1
14	Hose Tub to Drain Valve	9242-459-001	9242-459-001	9242-459-001	9242-459-001	9242-459-001	1
*	Replacement Seal Kit	9732-327-001	9732-327-001	9732-327-001	9732-327-001	9732-327-001	*

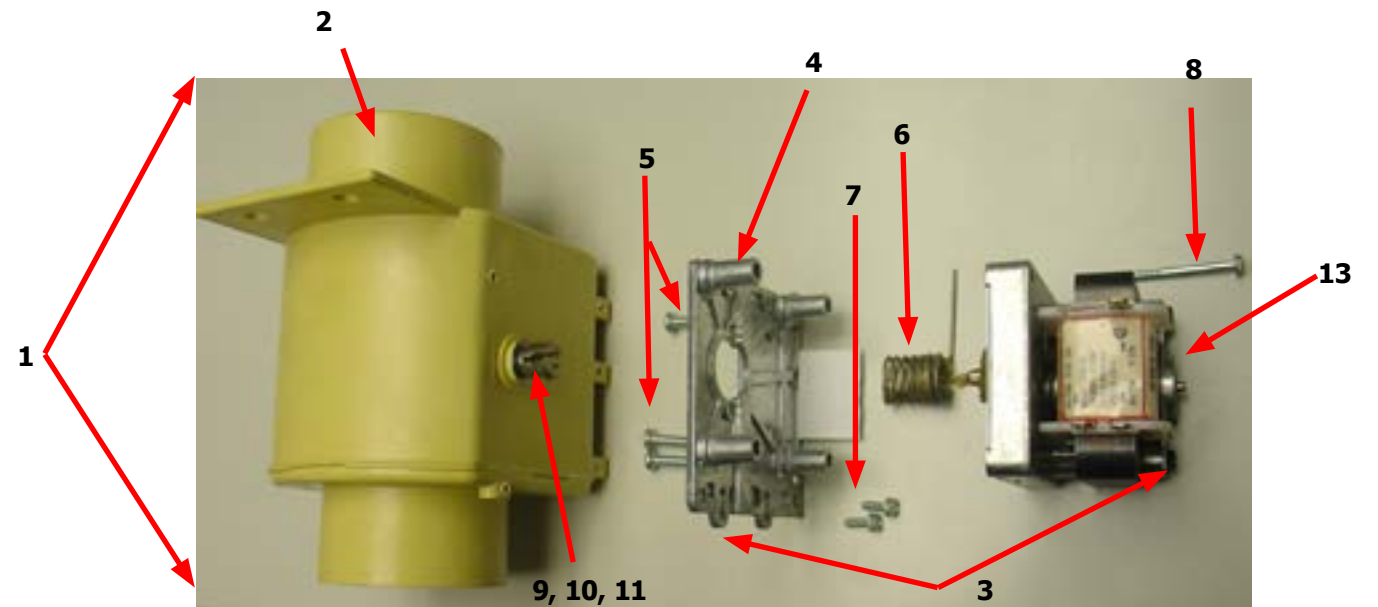

Chassis and Drain Part # by Model

Key	Description	T750	T-900	T950	T-1200	T1450	QTY
1	Base Assy,Frame	9945-112-002	9945-128-002	9945-128-002	9945-125-002	9945-133-002	1
2	Outer Tub Assy Before Serial #535659	9930-148-001	9930-147-001		9930-149-001		1
2	Outer Tub Assy After Serial #535659		9930-156-001	9930-156-001		9930-155-001	1
*	Tub & Cylinder Assy Before Serial #535659	9869-025-002	9869-023-001		9869-022-002		1
*	Tub & Cylinder Assy After Serial #535659		9869-027-001	9869-027-001		9869-026-001	1
3	Tub Front Before Serial #535659	9974-011-001	9178-148-001	9178-148-001			1
3	Tub Front After Serial #535659		9974-011-002	9974-011-002	9974-011-002	9178-056-001	1
*	Gasket, Tub Front	9206-421-002	9206-421-002	9206-421-002	9206-421-002	9206-421-003	1
4	Ring Assy, Tub Mtg-Front Clamp	9950-055-001	9950-055-001	9950-055-001	9950-055-001	9950-061-001	1
5	Bolt, Top Front Ring 3/8"-16 x 3"	9545-029-009	9545-029-009	9545-029-009	9545-029-009	9545-029-009	1
6	Nut WCAD 3/8"-16	8640-415-001	8640-415-001	8640-415-001	8640-415-001	8640-415-001	1
7	Ring Assy,Clamp Tub Mtg. to Frame	9950-053-002	9950-053-002	9950-053-002	9950-053-002		1
8	Bolt, 1/2" -13 x 2" Ring	9545-017-013	9545-017-013	9545-017-013	9545-017-013		1
9	Bolt, 1/2" -13 x 2" Ring	8640-417-005	8640-417-005	8640-417-005	8640-417-005		1
10	Bolt, 1/2" -13 x 2" Rings to Base	9545-017-013	9545-017-013	9545-017-013	9545-017-013	9545-017-013	2
11	Nut, Wizloc 1/2" x 13	8640-417-005	8640-417-005	8640-417-005	8640-417-005	8640-417-005	2
12	Washer, Flat 1/2"	8641-581-026	8641-581-026	8641-581-026	8641-581-026	8641-581-026	2
13	Hose, Tub to Drain Valve	9242-456-001	9242-456-001	9242-456-001	9242-456-001	9242-459-001	1
14	Clamp, Hose (Tub to Drain Valve)	8654-117-014	8654-117-014	8654-117-014	8654-117-014	8654-117-014	2
15	Valve, Drain	9379-187-004	9379-187-004	9379-187-004	9379-187-004	9379-187-004	1
*	Screw, Valve to Base 1/4ABx3/4	9545-030-002	9545-030-002	9545-030-002	9545-030-002	9545-030-002	2
*	Washer, Flat 1/4	8641-581-017	8641-581-017	8641-581-017	8641-581-017	8641-581-017	2
16	Hose, Drain Valve to Tube	9242-457-001	9242-457-001	9242-457-001	9242-457-001	9242-457-001	1
*	Clamp, Hose (Drain Valve to Tube)	8654-117-014	8654-117-014	8654-117-014	8654-117-014	8654-117-014	2
17	Tube Assy, Drain	9915-124-002	9915-124-002	9915-124-002	9915-128-002	9915-129-002	1
18	Clamp, Hose (Tube to Frame Bracket)	8654-117-014	8654-117-014	8654-117-014	8654-117-014	8654-117-014	1
*	Bracket, Drain Tube	9029-067-002					1
*	Screw Tube (Bracket to Base 1/4Bx3/4)	9545-030-002	9545-030-002	9545-030-002	9545-030-002		4
19	Hose, Overflow Tub To Drain Tube	9942-449-003	9942-449-003	9942-449-003	9942-449-003	9942-449-005	1
*	Clamp, Hose	8654-117-018	8654-117-018	8654-117-018	8654-117-018	8654-117-018	1
*	Tube, Suds overflow	9242-463-004	9242-463-004	9242-463-004	9242-463-004	9242-463-006	1
*	Clamp, Hose	8654-117-008	8654-117-008	8654-117-008	8654-117-008	8654-117-008	2
20	Hose, Pressure switch	9242-175-007	9242-175-007	9242-175-007	9242-175-004	9242-175-004	1
	Clamp, Hose	8654-117-015	8654-117-015	8654-117-015	8654-117-015	8654-117-015	1

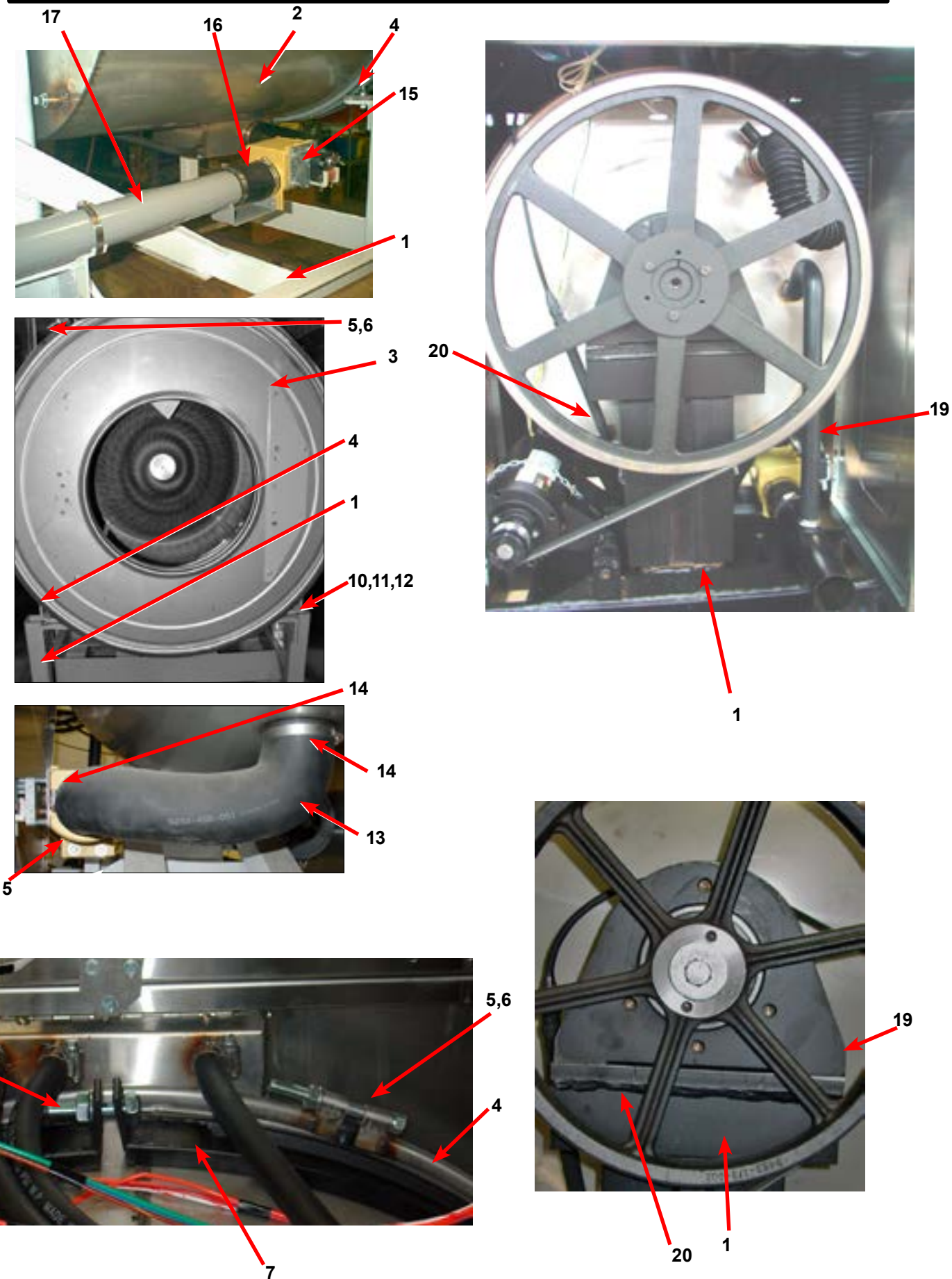

Electrical Components - Top Compartment

Key	Description	T-750	T-900	T-950	T-1200	T-1450	QTY
1	Trough Assy,Controls 208-240 volt (all parts below #2-#43)	9857-159-002	9857-154-001		9857-160-001	9857-191-001	1
*	Trough only	9839-015-001	9839-015-001		9839-015-001	9839-017-001	1
*	Screw, Trough Sides	9545-008-026	9545-008-026	9545-008-026	9545-008-026	9545-008-026	4
*	Lockwasher Exttooth #10	8641-582-006	8641-582-006	8641-582-006	8641-582-006	8641-582-006	4
2	Angle Support Trough	9003-278-001	9003-271-001				1
3	Screw, Trough Bracket	9545-008-026	9545-008-026	9545-008-026	9545-008-026	9545-008-026	3
4	Transformer, Control (Secondary Voltage to 115 volts)	8711-004-001	8711-004-001	8711-004-001	8711-004-001	8711-004-001	1
*	Screw, Mtg #8Bx1/4"	9545-045-001	9545-045-001	9545-045-001	9545-045-001	9545-045-001	4
*	Lockwasher #10	8641-582-006	8641-582-006	8641-582-006	8641-582-006	8641-582-006	4
*	Screw GRN. #10-32x 1/2"	9545-008-027	9545-008-027	9545-008-027	9545-008-027	9545-008-027	1
*	Lockwasher #10	8641-582-006	8641-582-006	8641-582-006	8641-582-006	8641-582-006	1
*	Lug, Grounding	8652-130-037	8652-130-037	8652-130-037	8652-130-037	8652-130-037	1
5	PCB assembly Relay Main	9473-006-001	9473-006-001	9473-006-001	9473-006-001	9473-006-001	1
*	Spacer Plastic #8x3/8"	9538-157-011	9538-157-011	9538-157-011	9538-157-011	9538-157-011	6
*	Nuts Hexkeps #6-32	8640-411-003	8640-411-003	8640-411-003	8640-411-003	8640-411-003	6
6	Harness, P17 Drain/Therm/Sol	9627-796-002	9627-796-002	9627-796-002	9627-796-002	9627-796-002	1
7	Harness P19/Water Valve	9627-795-004	9627-795-002	9627-795-004	9627-795-004	9627-795-004	1
8	Harness P8/P16	9627-794-001	9627-794-001	9627-794-004	9627-794-004	9627-794-001	1
9	Harness P20/P21	9627-793-001	9627-793-001	9627-793-001	9627-793-001	9627-793-001	1
*	Bushing , Wire 7/8	9053-067-002	9053-067-002	9053-067-002	9053-067-002	9053-067-002	2
*	Standoff Twistlock	9527-002-002	9527-002-002	9527-002-002	9527-002-002	9527-002-002	3
10	Dynamic Braking Resistor	9483-004-003	9483-004-003		9483-004-003	9483-004-003	2
11	Screws #10-32x1/2" (pnhdcr)	9545-012-008	9545-012-008	9545-012-008	9545-012-008	9545-012-008	4
12	Nuts, #10-32 UNF 2B	8640-413-002	8640-413-002	8640-413-002	8640-413-002	8640-413-002	4
*	Screw #6-32x5/16"	9545-044-006	9545-044-006	9545-044-006	9545-044-006	9545-044-006	4
*	Nuts Hex #6-32	8640-411-003	8640-411-003	8640-411-003	8640-411-003	8640-411-003	4
11	Terminal Block Assy, POWER	9897-034-001	9897-034-001	9897-034-001	9897-034-001	9897-034-001	1
*	Screw, Mtg 8Bx3/8"	9545-045-007	9545-045-007	9545-045-007	9545-045-007	9545-045-007	2
12	Strip, Terminal Marker	9558-027-001	9558-027-001	9558-027-001	9558-027-001	9558-027-001	1
13	Switch, Pressure Before Serial #538202	9539-457-002	9539-457-002	9539-457-002	9539-457-002		1
13	Switch, Pressure After Serial #538202	9539-457-004	9539-457-004	9539-457-004	9539-457-004	9539-457-004	1
*	Screw, Mtg #10Bx1/2"	9545-008-026	9545-008-026	9545-008-026	9545-008-026	9545-008-026	2
*	Electronic Pressure Swtich Kit	9732-314-001	9732-314-001	9732-314-001	9732-314-001	9732-314-001	*
14	Harness P5/Pressure		9627-803-001	9627-803-001	9627-803-001	9627-899-001	1
15	Transformer, (Step Down) 120/2.3 VAC&24 VAC 50/60hz	8711-009-001	8711-009-001	8711-009-001	8711-009-001	8711-009-001	1
*	Screw, Transformer Mtg #8Bx1/4"	9545-045-001	9545-045-001	9545-045-001	9545-045-001	9545-045-001	4
*	Lockwasher #6 exttooth	8641-582-005	8641-582-005	8641-582-005	8641-582-005	8641-582-005	4
16	Fuseholder	9200-001-002	9200-001-002	9200-001-002	9200-001-002	9200-001-002	1
16	Fuse 1.5 amp	8636-018-001	8636-018-001	8636-018-001			1
16	Fuse 2.5 amp				8636-018-004	8636-018-004	1
17	Label Fuse 1.5 amp Rear	8502-716-001	8502-716-001	8502-716-001			1
17	Label Fuse 2.5 amp Rear				8502-716-002	8502-716-002	1
*	Bracket Terminal Mounting,		9029-076-001	9029-076-001			1
	Screw #10Bx1/2"	9545-008-026	9545-008-026	9545-008-026	9545-008-026	9545-008-026	4

Electrical Components - Top Compartment

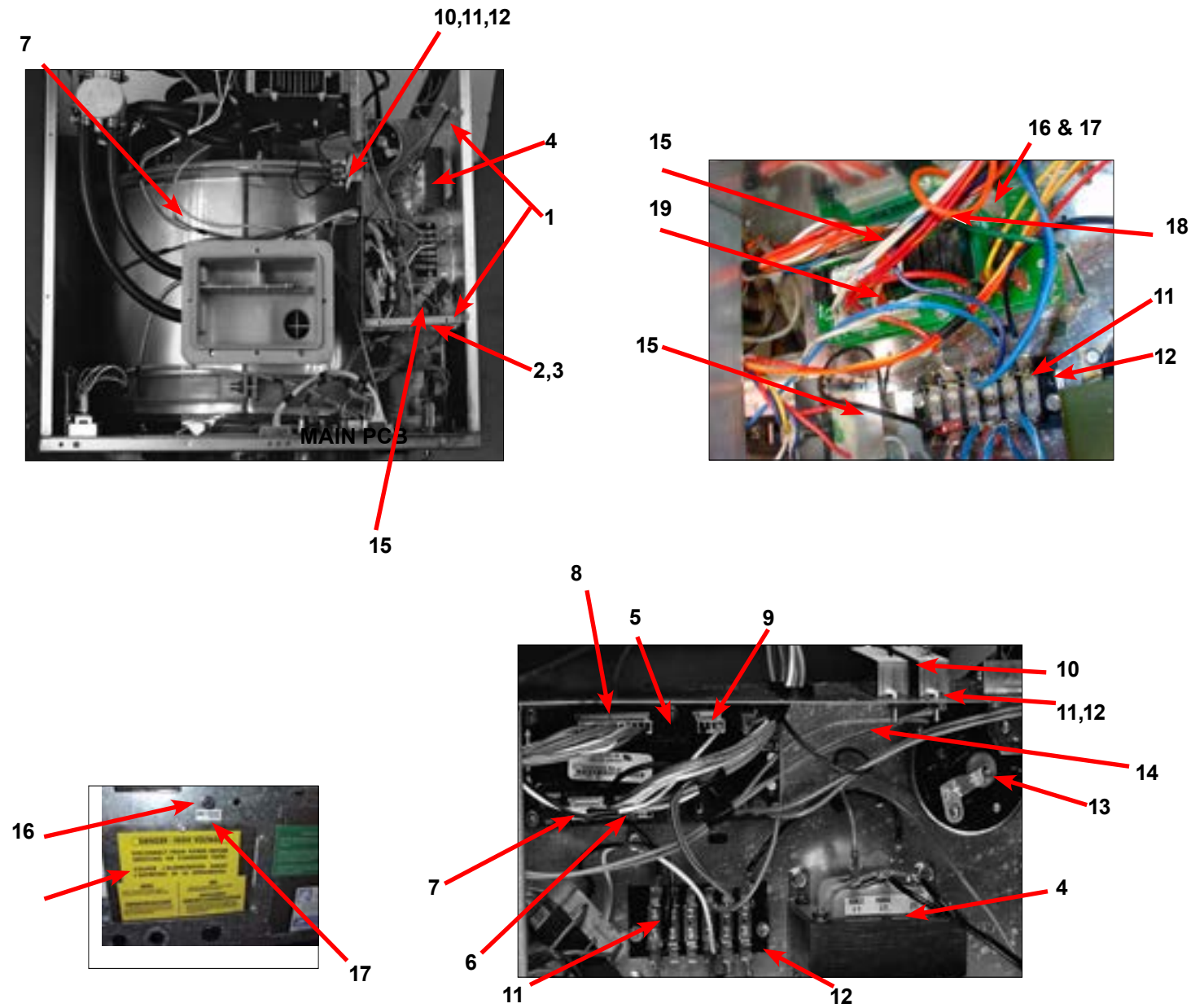

Key	Description	T-750	T-900	T-950	T-1200	T-1450	QTY
*	Terminal Lug, Solderless	8652-134-001	8652-134-001	8652-134-001	8652-134-001	8652-134-001	1
*	Terminal Block, Power	9897-033-001	9897-035-001	9897-035-001	9897-033-002	9897-035-001	1
*	Strip, Terminal Marker Power	9558-025-001	9558-025-001	9558-025-001	9558-025-001	9558-025-001	
*	Wiring Harness Power Terminal	9627-747-003	9627-747-002	9627-747-002	9627-747-002		1
18	Cover Electrical	9074-267-001	9074-267-001	9074-267-001	9074-267-007	9074-267-001	1
19	Label, Warning	8502-614-001	8502-614-001	8502-614-001	8502-614-001	8502-614-001	1
20	Label, Warning	8502-639-001	8502-639-001	8502-639-001	8502-639-001	8502-639-001	1
*	Screw 8B x 1/2	9545-008-026	9545-008-026	9545-008-026	9545-008-026	9545-008-026	2
*	Fuseholder	9200-001-002	9200-001-002	9200-001-002	9200-001-002	9200-001-002	1
*	Fuse 1.5 amp	8636-018-001	8636-018-001	8636-018-001			1
*	Fuse 2.5 amp				8636-018-004	8636-018-004	1

Control Panel Part # by Model

Key	Description	T-750	T-900	T-950	T-1200	T-1450	QTY
1	Panel Control Assembly(panel only) Before Serial #530673	9989-500-001	9989-500-001		9989-500-001		1
1	Panel Control Assembly(panel only) After Serial #530673	9989-525-001	9989-525-001	9989-525-001	9989-525-001	9989-529-001	1
1a	Retainer, Coin Acceptor	9486-149-001	9486-149-001	9486-149-001	9486-149-001	9486-149-001	2
1b	Screw, Torx T-10 4Bx5/8ss	9545-053-002	9545-053-002	9545-053-002	9545-053-002	9545-053-002	4
*	Screw, Hxwshrhdunct #10Bx 1/2"	9545-008-026	9545-008-026	9545-008-026	9545-008-026	9545-008-026	4
2	Post Locator Top	9467-024-001	9467-024-001	9467-024-001	9467-024-001	9467-024-001	2
*	Nut Hexkeps #6-32	8640-411-003	8640-411-003	8640-411-003	8640-411-003	8640-412-005	2
3	Locator Panel	9355-001-001	9355-001-001	9355-001-001	9355-001-001	9355-001-001	2
*	Screw FillHDCR 10Bx1/2" Guide	9545-008-025	9545-008-025	9545-008-025	9545-008-025	9545-008-023	2
*	Spacer Pushbutton (Micro)	9538-178-001	9538-178-001	9538-178-001	9538-178-001	9538-178-001	1
*	Retainer Pushbutton (Micro)	9486-150-001	9486-150-001	9486-150-001	9486-150-001	9486-150-001	1
*	Nut Hexelasticstop #4-40	8640-424-002	8640-424-002	8640-424-002	8640-424-002	8640-424-002	2
10	Pushbutton Control (coin), Blue	9035-062-001	9035-062-001	9035-062-001	9035-062-001	9035-062-001	1
10	Pushbutton Control (coin), Black	9035-062-002	9035-062-002	9035-062-002	9035-062-002	9035-062-002	1
7	PCB assembly Control /Display STOP	9473-009-005	9473-009-005	9473-009-005	9473-009-005	9473-009-005	1
11	Spacer Plastic #6x9/16	9538-157-018	9538-157-018	9538-157-018	9538-157-018	9538-157-018	5
11	Nut Elasticstop #6-32	8640-411-002	8640-411-002	8640-411-002	8640-411-002	8640-411-002	5
12	Harness LEDPCB	9627-797-001	9627-797-001	9627-797-001	9627-797-001	9627-797-001	1
8	Harness Doorlock, Switches	9627-791-004	9627-791-005	9627-791-005	9627-791-005	9627-791-006	1
16	PCB assembly Mode lights	9473-005-001	9473-005-001	9473-005-001	9473-005-001	9473-005-001	1
*	Spacer Plastic #6x9/16	9538-157-018	9538-157-018	9538-157-018	9538-157-018	9538-157-018	2
*	Nut Hexkeps #6-32	8640-411-003	8640-411-003	8640-411-003	8640-411-003	8640-411-003	2
19	Light, LED,ADD BLEACH Assembly	9794-001-001	9794-001-001	9794-001-001	9794-001-001	9794-001-001	1
*	Spacer Plastic #6x9/16	9538-157-018	9538-157-018	9538-157-018	9538-157-018	9538-157-018	2
*	Nut Hexeps #6-32	8640-411-003	8640-411-003	8640-411-003	8640-411-003	8640-411-003	2
9	Nameplate,Control Panel (one piece) Blue Before Serial #535659	9412-162-001	9412-141-001		9412-142-001		1
	Nameplate,Control Panel (one piece) Black Before Serial #535659		9412-165-001		9412-173-001		1
	Nameplate,Control Panel (one piece) Blue After Serial #535659	9412-162-001	9412-198-001	9412-191-001		9412-193-001	1
	Nameplate,Control Panel (one piece) Black After Serial #535659	9412-172-001	9412-199-001	9412-192-001		9412-194-001	1
22	Switch Assembly Emergency Stop (includes wire harness)	9732-223-001	9732-223-001	9732-223-001	9732-223-001	9732-223-001	1
*	Spacer Plastic #8x5/16 E-Stop	9538-157-020	9538-157-020	9538-157-020	9538-157-020	9538-157-020	2
*	Nut HexKep #8-32 E-Stop	8640-412-005	8640-412-005	8640-412-005	8640-412-005	8640-412-005	2
26	Battery	8612-001-001	8612-001-001	8612-001-001	8612-001-001	8612-001-001	1
*	Plastic Shield over main PCB	9550-184-001	9550-184-001	9550-184-001	9550-184-001	9550-184-001	1
27	Plate to mount e-stop button	9452-725-001	9452-725-001	9452-725-001	9452-725-001	9452-725-001	1
*	Bracket Retainer, Front Panel	9029-191-001	9029-191-001	9029-191-001	9021-191-001		1
*	Bracket Retainer, Front Panel					9029-191-001	2
*	Screw-#10Bx1/2	9545-008-026	9545-008-026	9545-008-026	9545-008-026		3
*	Screw-#10Bx1/2					9545-008-026	6

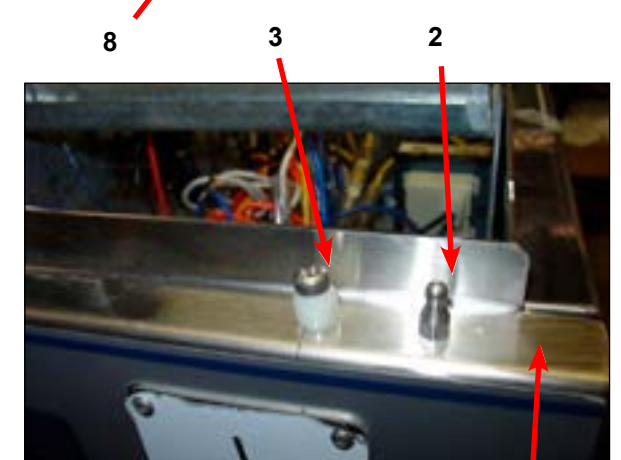
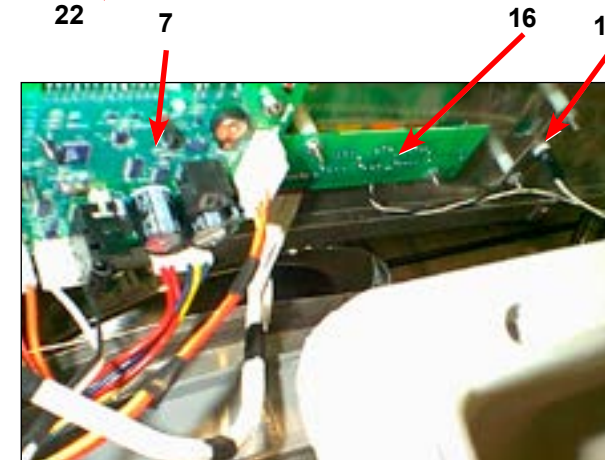
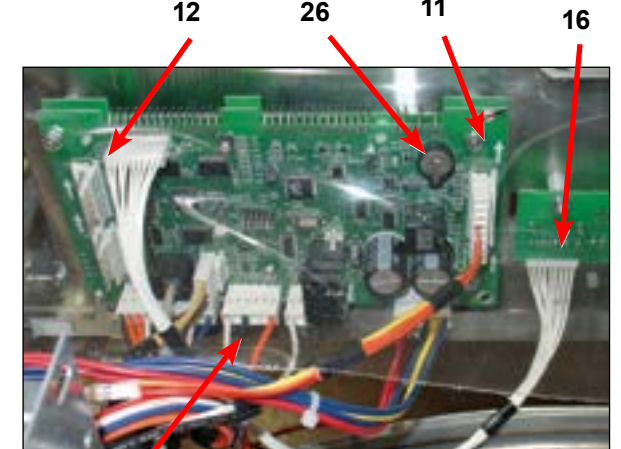
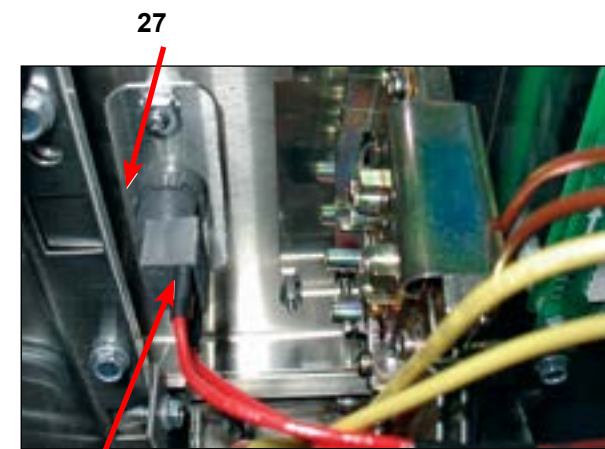
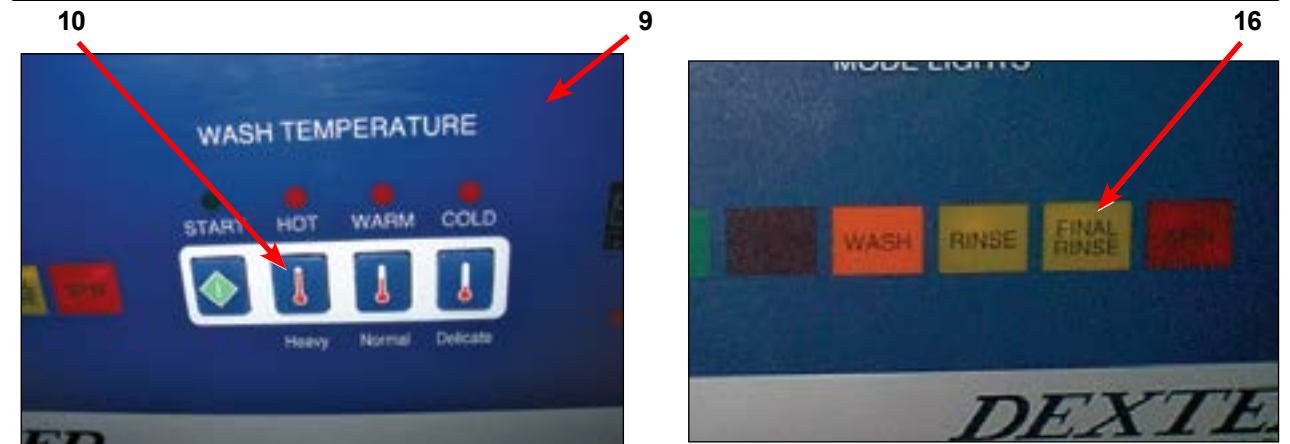

Labels and Diagrams All WCAD Models

Key	Description	T750	T-900	T950	T-1200	T1450	QTY
*	Booklet Owners	8514-157-001	8514-099-001	8514-183-001	8514-159-001		1
*	Wiring Diagram, Coin	9506-358-001	9506-127-001		9506-129-001	9506-488-001	1
*	Wiring Diagram Easy Card (120 V)						1
*	Wiring Diagram (Easy Card)		9506-113-001	9506-486-001	9506-115-001		1
*	Transient Voltage Surge Suppressor Infomational		8507-330-001		8507-330-001	8507-330-001	1
*	Instructions Spin Direction		8507-275-001		8507-275-001	8507-275-001	1
*	Wiring Schematic, Coin (120 V)						1
*	Wiring Schematic, Easy Card (120 V)						1
*	Wiring Schematic, Coin	9506-357-001	9506-126-001	9506-486-001	9506-128-001	9506-488-001	1
*	Wiring Schematic, Easy Card		9506-112-001		9506-114-001		1
*	Label High Voltage Warning	8502-614-004	8502-614-004	8502-614-004	8502-614-004	8502-614-004	1
*	Label Fusing & Installation	8502-619-003	8502-619-003	8502-619-003	8502-619-003	8502-619-008	1
*	Label Quality	8511-001-002	8511-001-002	8511-001-002	8511-001-002	8511-001-002	1
1	Label Warning Risk of Injury (Blue)	8502-722-002	8502-722-002	8502-722-002	8502-722-002	8502-722-002	1
1	Label Warning Risk of Injury (Black)	8502-741-001	8502-741-001	8502-741-001	8502-741-001	8502-741-001	
2	Label Warning Door Opening (Blue)	8502-723-001	8502-723-001	8502-723-001	8502-723-001	8502-723-001	1
2	Label Warning Door Opening (Black)	8502-742-001	8502-742-001	8502-742-001	8502-742-001	8502-742-001	
3	Label Dispenser (Blue)		8502-687-001	8502-687-001	8502-687-001	8502-687-001	1
3	Label Dispenser (Black)		8502-745-001	8502-745-001	8502-745-001	8502-745-001	1



Door Label

2



Risk of Injury Label

1

Top Dispenser Label T-1200



3

Section 9:

Coin Handling

Parts:

Wiring Diagrams
& Schematics &
maintenance Procedures

Coin Handling Group Part # Micro Switch

Key	Description	T-750	T-900	T-950	T-1200	T-1450	QTY
1	Vault, Assy Grey	9942-037-001	9942-037-001	9942-037-001	9942-037-001		1
1	Vault, Assy. Black	9942-037-005	9942-037-005	9942-037-005	9942-037-005		1
*	Screw, 10Bx 1/2" Vault Mtg	9545-008-026	9545-008-026	9545-008-026	9545-008-026		2
*	Screw, 10AB x 1/2" Vault Mtg	9545-008-031	9545-008-031	9545-008-031	9545-008-031		2
2	Coin Chute Assy.	9119-031-001	9119-031-001	9119-031-001	9119-028-001	9119-028-001	1
*	Screw, Coin Vault Chute Mtg	9545-008-001	9545-008-001	9545-008-001	9545-008-001	9545-008-001	1
3	Coin Acceptor chute without penny rejector for mechanical drop (standard)	9119-025-002	9119-025-002	9119-025-002	9119-025-002		1
*	Screw, Acceptor Mtg	9545-020-004	9545-020-004	9545-020-004	9545-020-004	9545-020-004	4
*	Nut	8640-424-002	8640-424-002	8640-424-002	8640-424-002	8640-424-002	4
4	Switch, Coin (fits single coin mechanical drop)	9732-126-001	9732-126-001	9732-126-001	9732-126-001		1
5	Coin Acceptor chute with penny rejector for mechanical drop (optional)	9119-025-001	9119-025-001	9119-025-001	9119-025-001		
6	Button Coin Return Retainer	9486-133-001	9486-133-001	9486-133-001	9486-133-001		1
7	Coin Acceptor Mechanical Complete	9021-001-010	9021-001-010	9021-001-010	9021-001-010		1
8	Soloid, Coin Blocking (V-Series)						1
*	Screw, Highth Bar/Chute 3mm	9545-039-002	9545-039-002	9545-039-002	9545-039-002		2
9	Vertical Chute Mounting Screw	9545-025-020	9545-025-020	9545-025-020	9545-025-020		2
*	Harness, Coin Switch V& A Series	9627-792-001	9627-792-001	9627-792-001	9627-792-001		1

NOTE: COIN BOX AND HARDWARE KIT AND COIN BOX LOCK NOT INCLUDED WITH MACHINE.

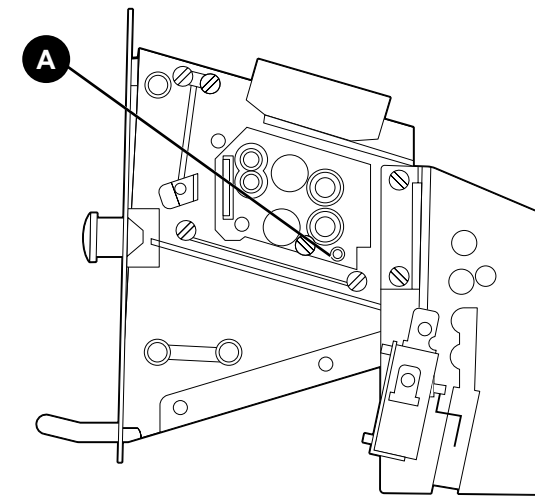
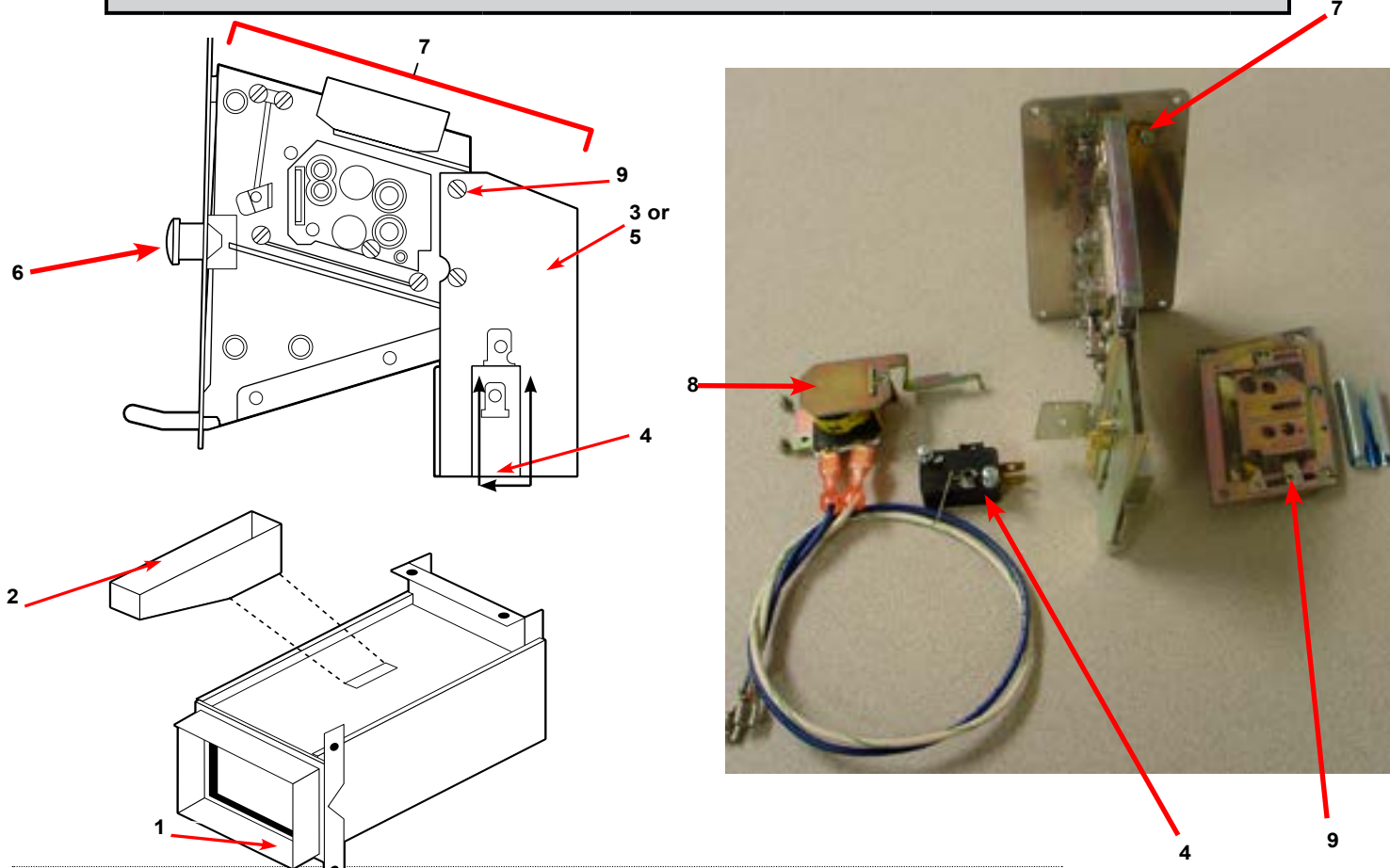

Left View Coin Drop Acceptor

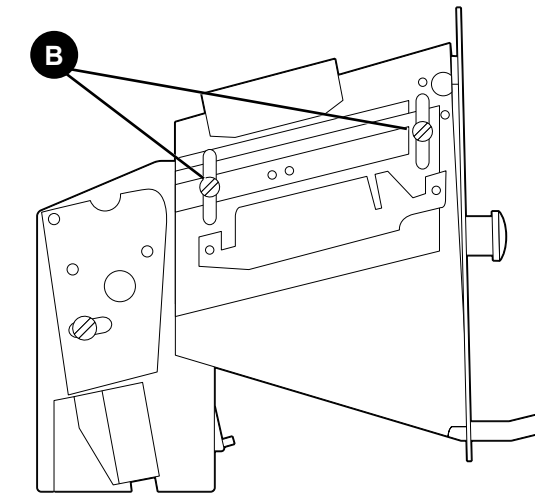

Right View Coin Drop Acceptor

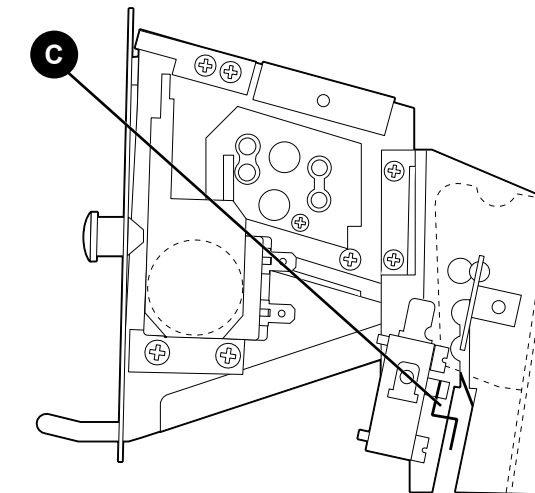

Mechanical Acceptor

Standard Coin Drop Acceptor

The drop style coin acceptor contains a coin switch that is actuated by each good coin that is accepted.

Removal

The coin acceptor is removed by loosening the two Torx T-10 machine screws on the right side and by removing completely the two Torx T-10 machine screws on the left side (#T-10 Torx driver, Dexter Pt. No. 8545-051-003). There are locking nuts on the back side that will have to be held. Needle-nose pliers work well for this. Sliding the acceptor to the left will remove it from the slots in the front panel. This gives access to the coin switch and acceptor for adjustments.

Coin Thickness Adjustment (see diagram)

On the right side of the acceptor there is a coin thickness adjusting screw "A" with a locking nut. To allow for different thickness coins the screw can be turned in to accept thicker coins and turned out to reject thicker coins. Start with a quarter of a turn on this screw and be sure to retighten the lock nut after adjustment.

Coin Height Adjustment (see diagram)

On the left side of the acceptor is a coin height adjusting bar "B". This bar is adjusted by loosening the two mounting screws and moving both ends of the bar up or down equal amounts. The bar should be raised as high as possible while still accepting the correct coins. If it is raised up too high, the good coins will be rejected.

Coin Switch Adjustment (see diagram)

The normally open coin switch "C" should click (close) soon after the coin hits the operator wire. However, there must be enough travel to allow the switch to reset (open) once the coin has passed. Adjustment should be made by bending the wire very close to its attachment point.

Optical Coin Acceptor

Starting after serial# 515483

Key-	Description	T-750	T-900	T-950	T-1200	T-1450	
1	Optical Coin Acceptor	9021-092-002	9021-092-002	9021-092-002	9021-092-002	9021-092-002	1
2	Replacement Optical Sensor	9801-099-001	9801-099-001	9801-099-001	9801-099-001	9801-099-001	1
*	Screw, Highth Bar, 3mm	9545-039-002	9545-039-002	9545-039-002	9545-039-002	9545-039-002	2

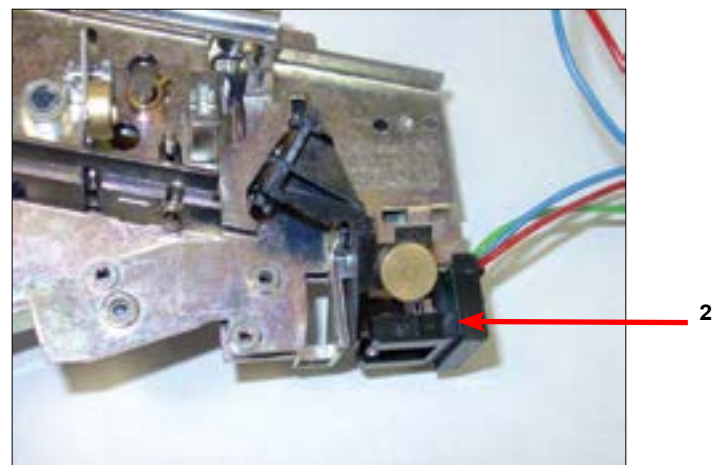
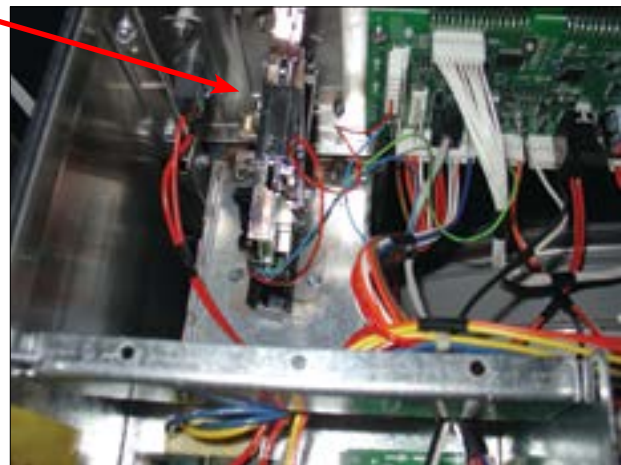
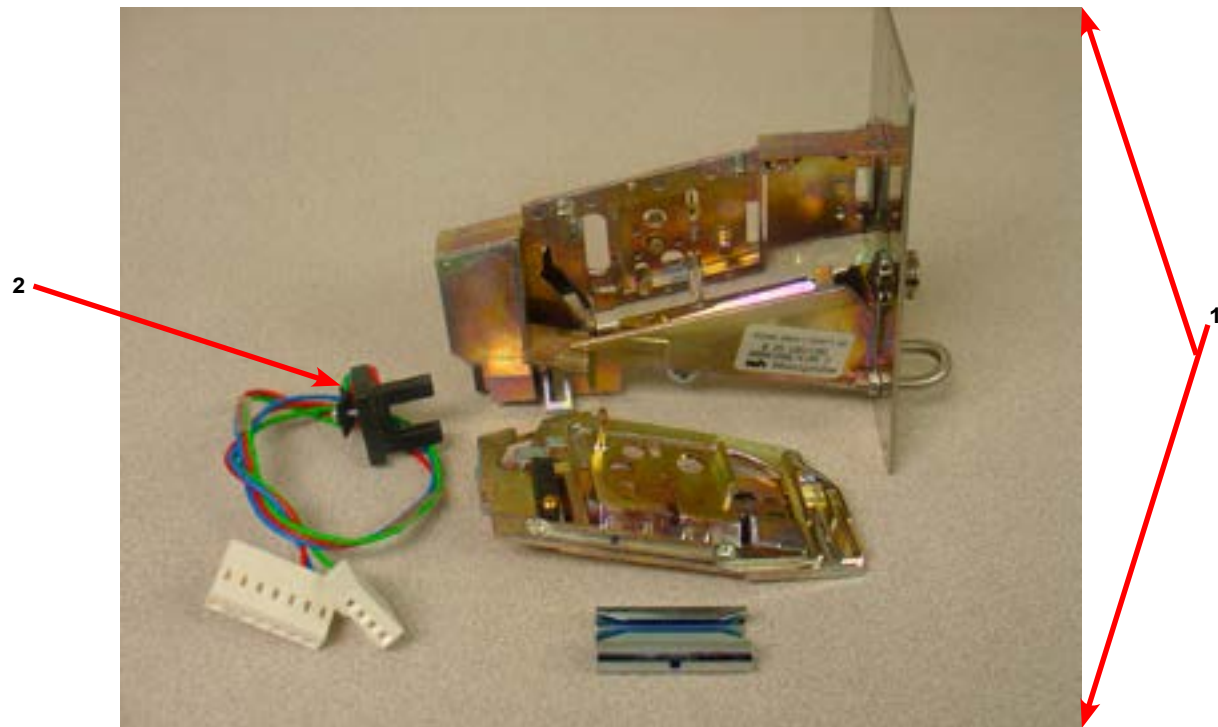

Imonex Optical Coin Acceptor

Starting after serial# 515483

Key-	Description	T-750	T-900	T-950	T-1200	T-1450	
1	Optical Coin Acceptor					9021-034-001	1

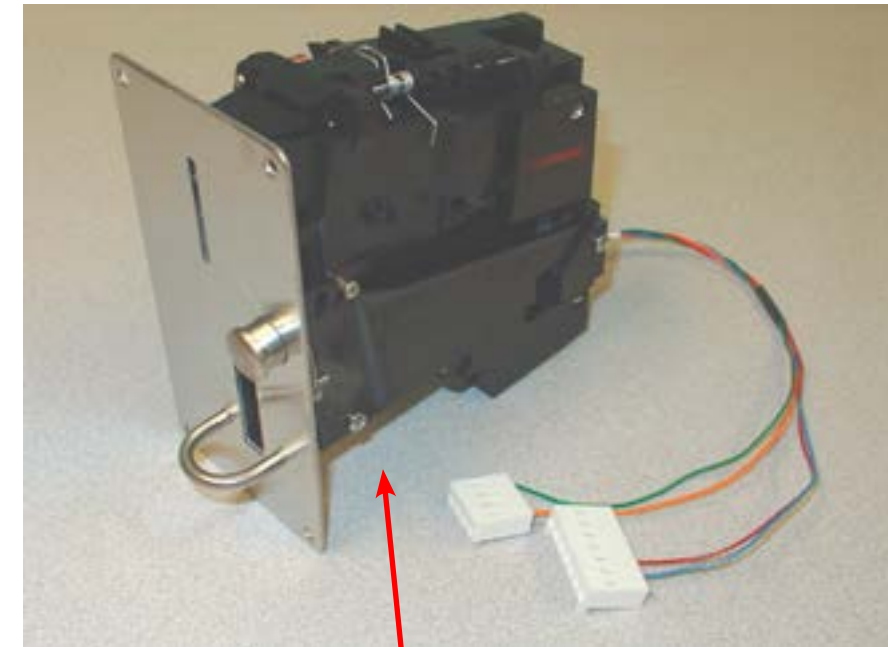

Electronic Acceptor Coin Drop

Setting the electronic coin acceptor switches

Some washer models come equipped with an electronic coin acceptor. Follow the instructions below for setting the switches for the desired country and currencies.

1. The electronic coin acceptor has switch settings depending on the coins and country. See the table below for available values of the left and right coin inputs for the available countries.

WARNING: turn power off before and leave power off when changing the switches of the electronic coin acceptor.

2. Turn power back on and test coins to ensure proper operation.

Acceptor P/N	Country	Left Coin	Right Coin	SWs 1-8	SWs 9-16
9021-028-001	Canada	25¢		↓↑↑↑↑↑↓	↓↑↑↑↑↑↓
	Canada		\$1	↑↑↓↑↑↑↓	↓↑↑↑↑↑↓
	Canada		\$2	↑↑↑↑↓↑↓	↓↑↑↑↑↑↓
				↓↑↑↑↑↑↓	↑↓↑↑↑↑↓
				↑↑↓↑↑↑↓	↑↓↑↑↑↑↓
				↓↑↑↑↑↑↓	↑↑↓↑↑↑↓
				↑↑↓↑↑↑↓	↑↑↓↑↑↑↓
				↓↑↑↑↑↑↓	↑↑↑↓↑↑↓
			Greenwald 118-1 Token	↑↑↑↑↑↑↓	↑↑↑↑↓↑↓
			Greenwald 118-5 Token	↑↑↑↑↑↑↓	↑↑↑↑↓↑↓
		U.S.A.	25¢	↓↑↑↑↑↑↓	↑↑↑↑↑↑↓
		U.S.A.		\$1	↑↑↓↑↑↑↓
9021-011-001	Australia	10¢		↓↑↑↑↑↑↓	↑↓↑↑↑↑↓
	Australia	20¢		↑↑↓↑↑↑↓	↑↓↑↑↑↑↓
	Australia		\$1	↑↑↑↑↓↑↓	↑↑↓↑↑↑↓
	Australia		\$2	↑↑↑↑↑↑↓	↓↑↓↑↑↑↓
	New Zealand	10¢		↓↑↑↑↑↑↓	↑↓↑↑↑↑↓
	New Zealand	20¢		↑↑↓↑↑↑↓	↑↓↑↑↑↑↓
	New Zealand		\$1	↑↑↑↑↓↑↓	↑↑↑↓↑↑↓
	New Zealand		\$2	↑↑↑↑↑↑↓	↓↑↓↑↑↑↓
	Hong Kong	\$5		↓↑↑↑↑↑↓	↑↑↑↑↓↑↓
	Hong Kong		\$10	↑↑↑↑↓↑↓	↑↑↑↓↑↑↓
			Greenwald 118-1 Token	↑↑↑↑↑↑↓	↑↑↑↑↓↑↓
			Greenwald 118-5 Token	↑↑↑↑↑↑↓	↑↑↑↑↓↑↓

NOTE: Coins and tokens in the left coin column will result in one pulse to the left coin input.

NOTE: The \$1, 500¥, 50NT, and \$10 coins in the right coin column will result in one pulse to the right coin input, while the \$2 coins will result in two pulses to the right coin input.

Note: Acceptance of multiple coins per country and multiple tokens is allowed. Only the down/off setting for each coin and token is required to accept that coin or token.

Maintenance Instructions

Electronic Acceptor

1. Instructions to open the flap of the coin selector



Original situation



Move spring downwards to free the catch.

NOTE:

- Do not lift the spring
- Do not over bend the spring in any direction.



Open the flap of the coin selector.

2. Assembly instructions to change a spring

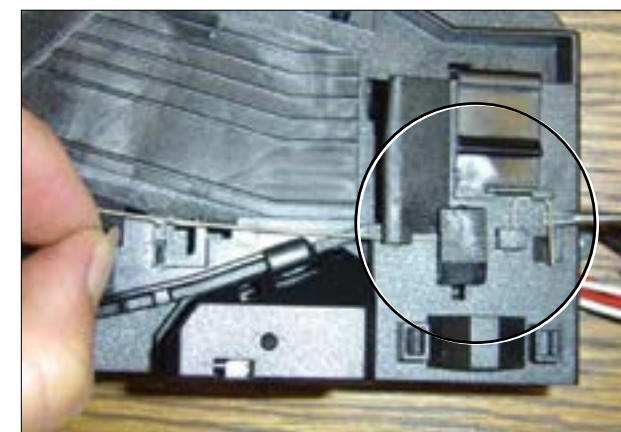

Lift the right end of the spring by means of a screw driver.



Pull the spring approximately 3 mm to the left.

Electronic Acceptor

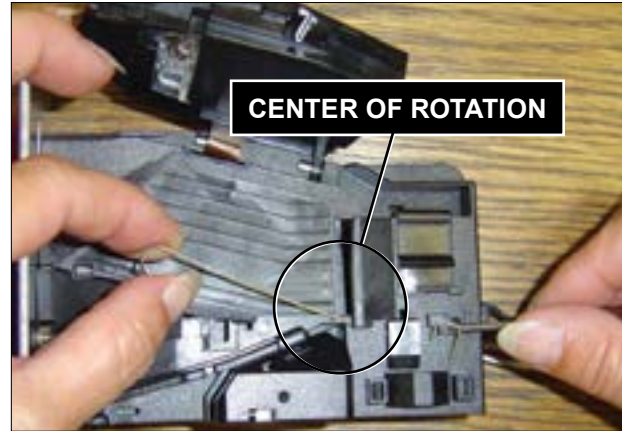

Rotate the spring clockwise for about 40 to 60 degrees until it becomes free of the protrusion.

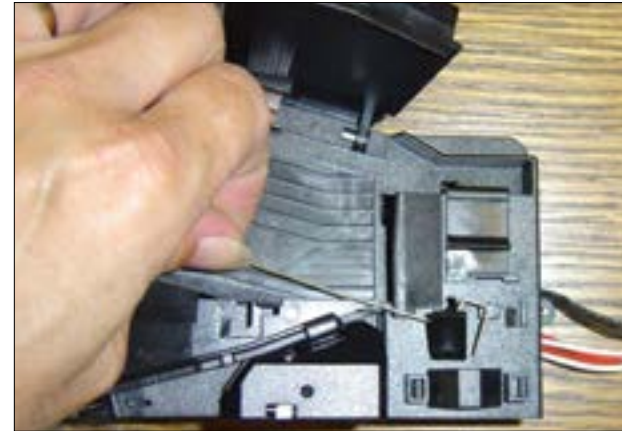

Lift off the spring with the attached plastic part.

3. Assembly of a new spring



Attach the plastic part to the new spring.



Place the plastic part in its position (slot).

Push the spring below the protrusion by means of a small screw driver.



Push the spring lateral to the right until its snaps into its proper position.

Electronic Acceptor

4. Close the coin selector



To shut the coin selector follow pictures 1 to 3 in reverse order.

5. Cleaning the electronic coin selector

The EMP 500 v4 is an extraordinarily robust coin selector and operates relatively maintenance free. However, it should be cleaned at regular intervals (minimum once a year) especially if it is operating in an environment with high levels of dust, smoke or nicotine. The cleaning intervals are of course dependent on the level of air borne contaminants.



Clean the coin path with a soft brush and wipe the exposed surfaces. Use an alcohol moistened cloth. If you find solid residues stuck to the coin rail (pa-



tina) remove it with an alcohol moistened cloth.



Optical sensors may be cleaned with a soft brush or very carefully with an air spray duster.



Location of the optical sensor within coin outlet.

50Lb. Express Coin Micro Switch Schematic 208-240V

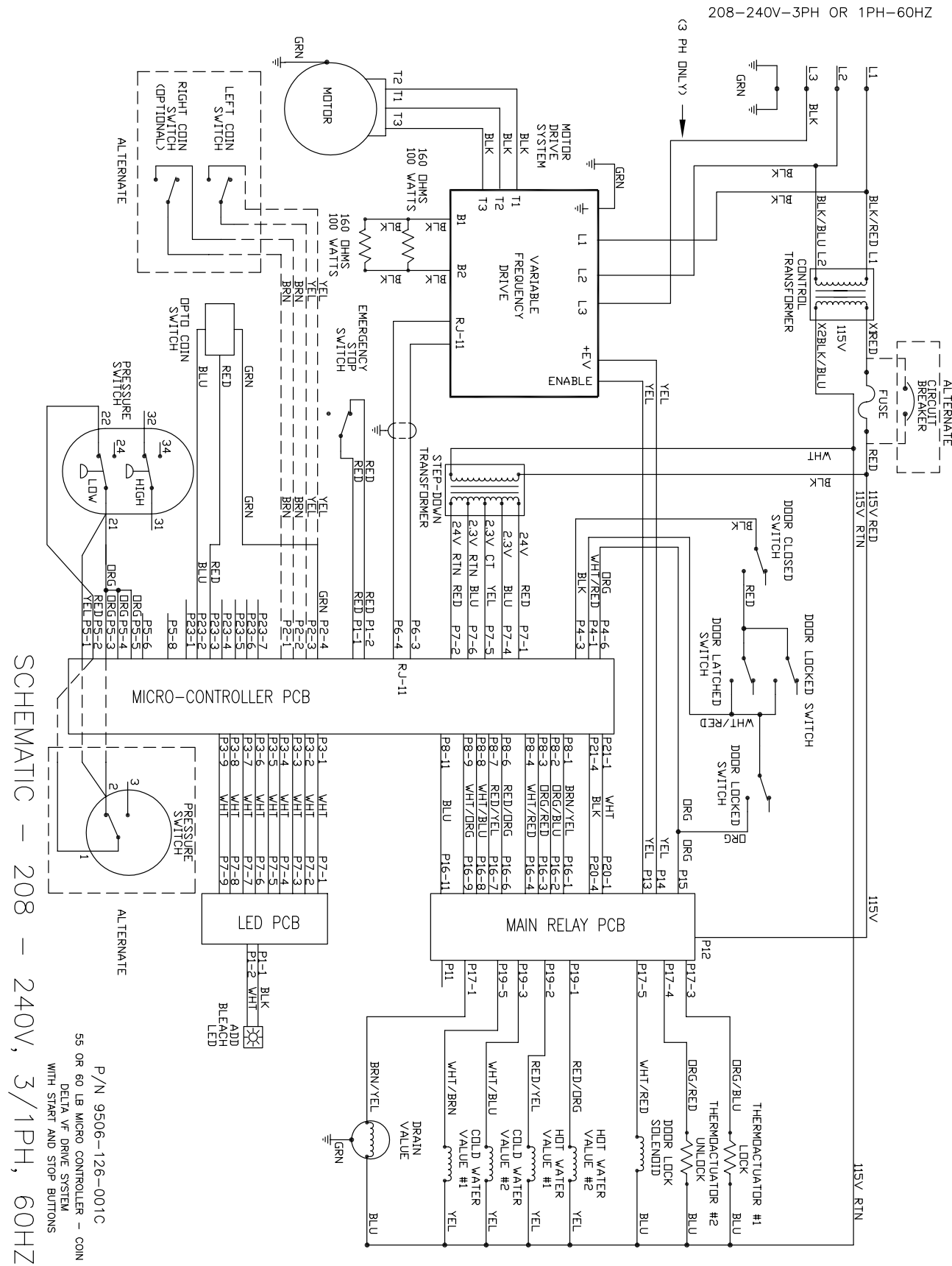

SCHEMATIC - 208 - 240V, 3/1PH, 60HZ

P/N 9506-126-001C
55 OR 60 LB MICRO CONTROLLER - COIN
DELTA VF DRIVE SYSTEM
WITH START AND STOP BUTTONS

50Lb. Express Coin Micro Switch Diagram 208-240V

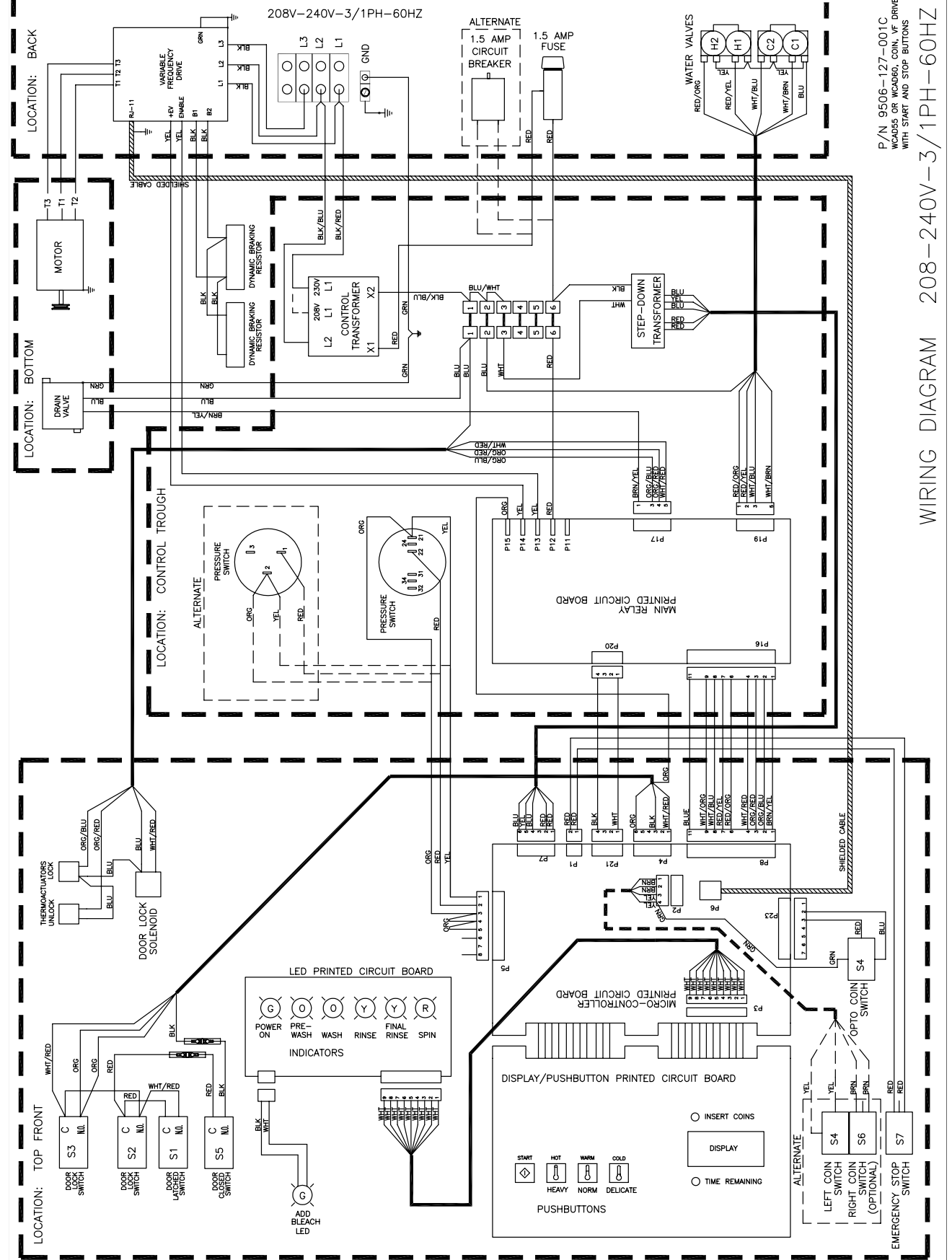

WIRING DIAGRAM - 208 - 240V, 3/1PH, 60HZ

50Lb. Express Electronic Acceptor Schematic 208-240V

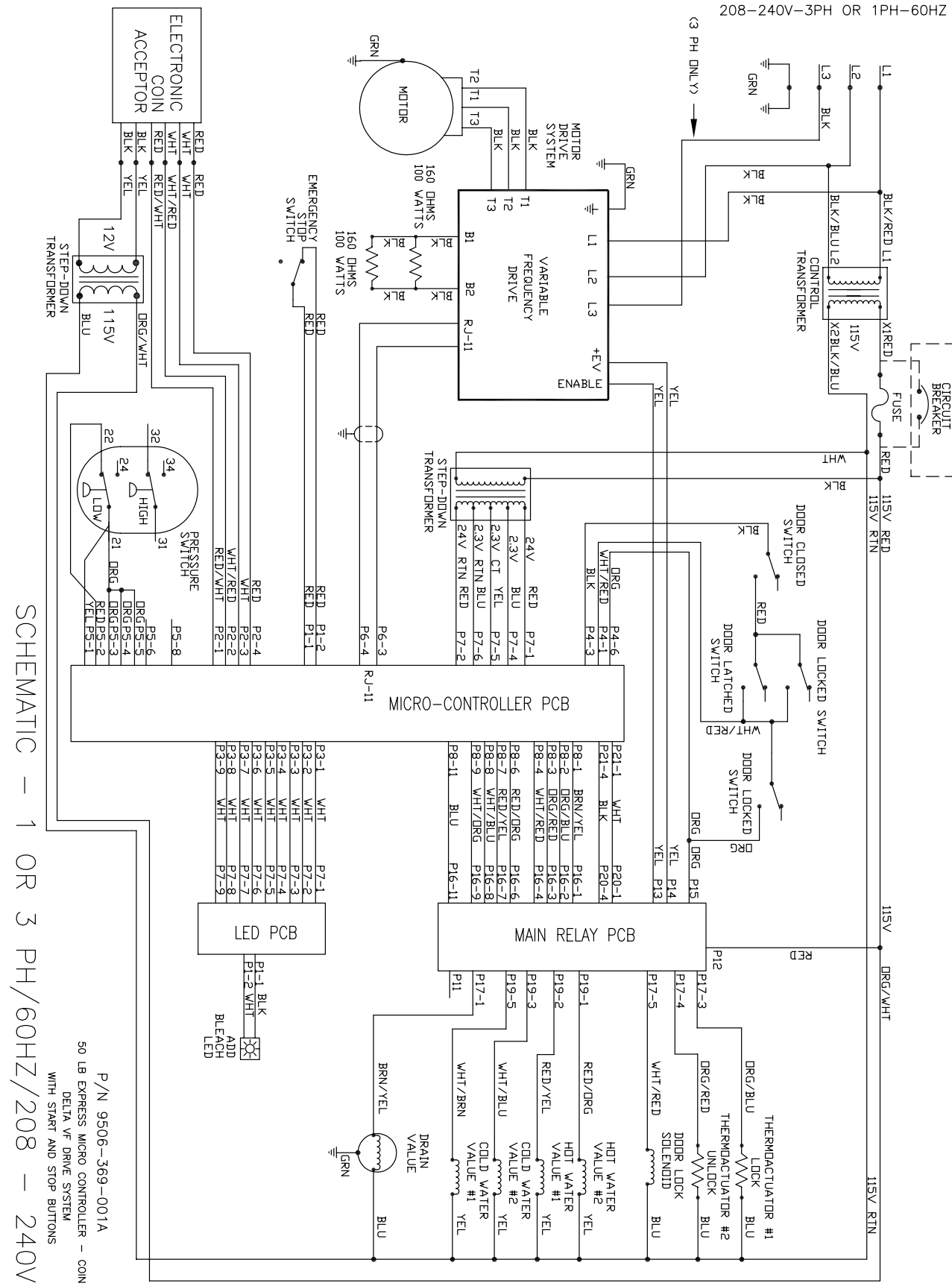

50Lb. Express Electronic Acceptor Diagram 208-240V

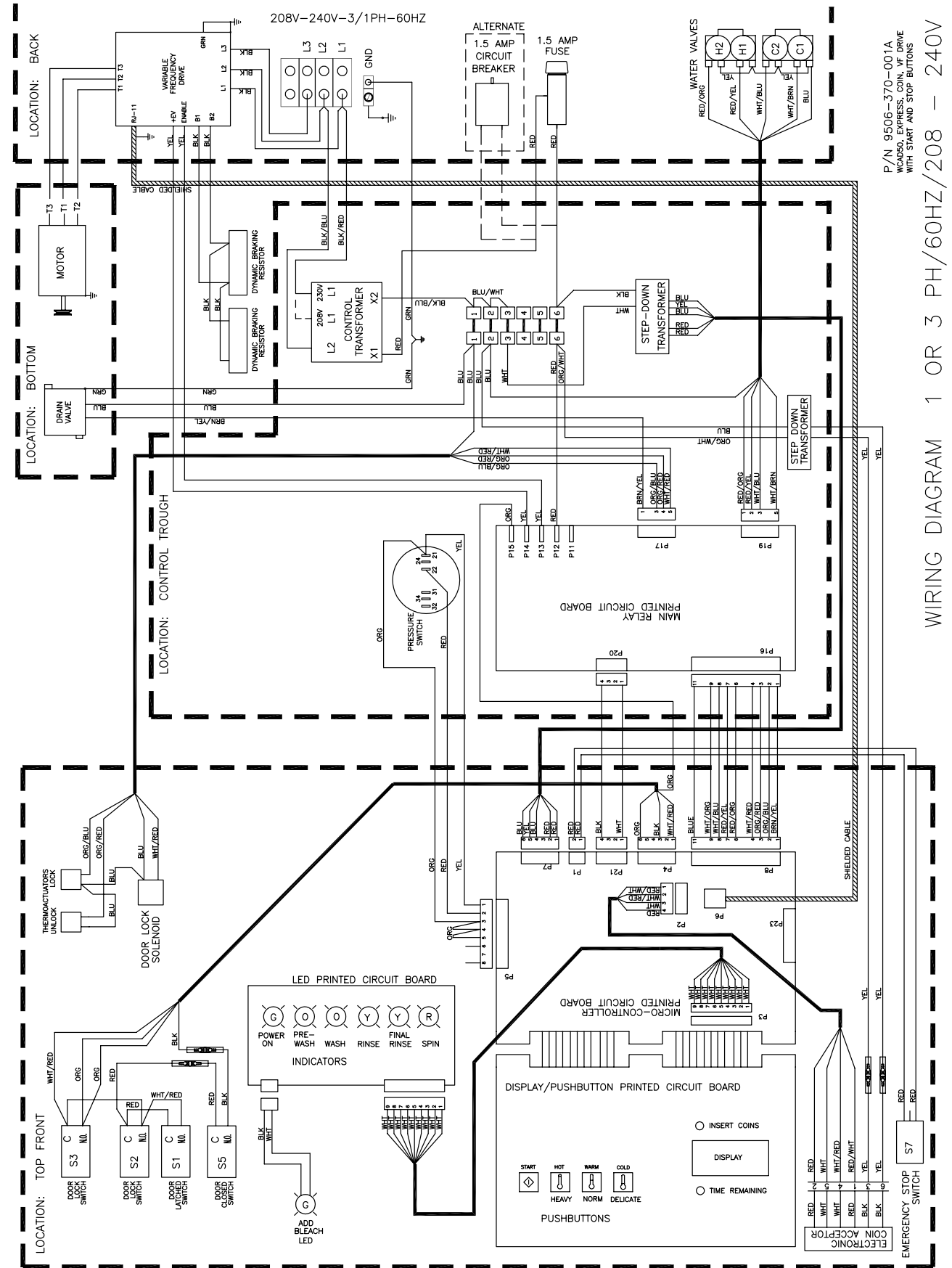

60Lb. Non-Express Coin Micro Switch Schematic

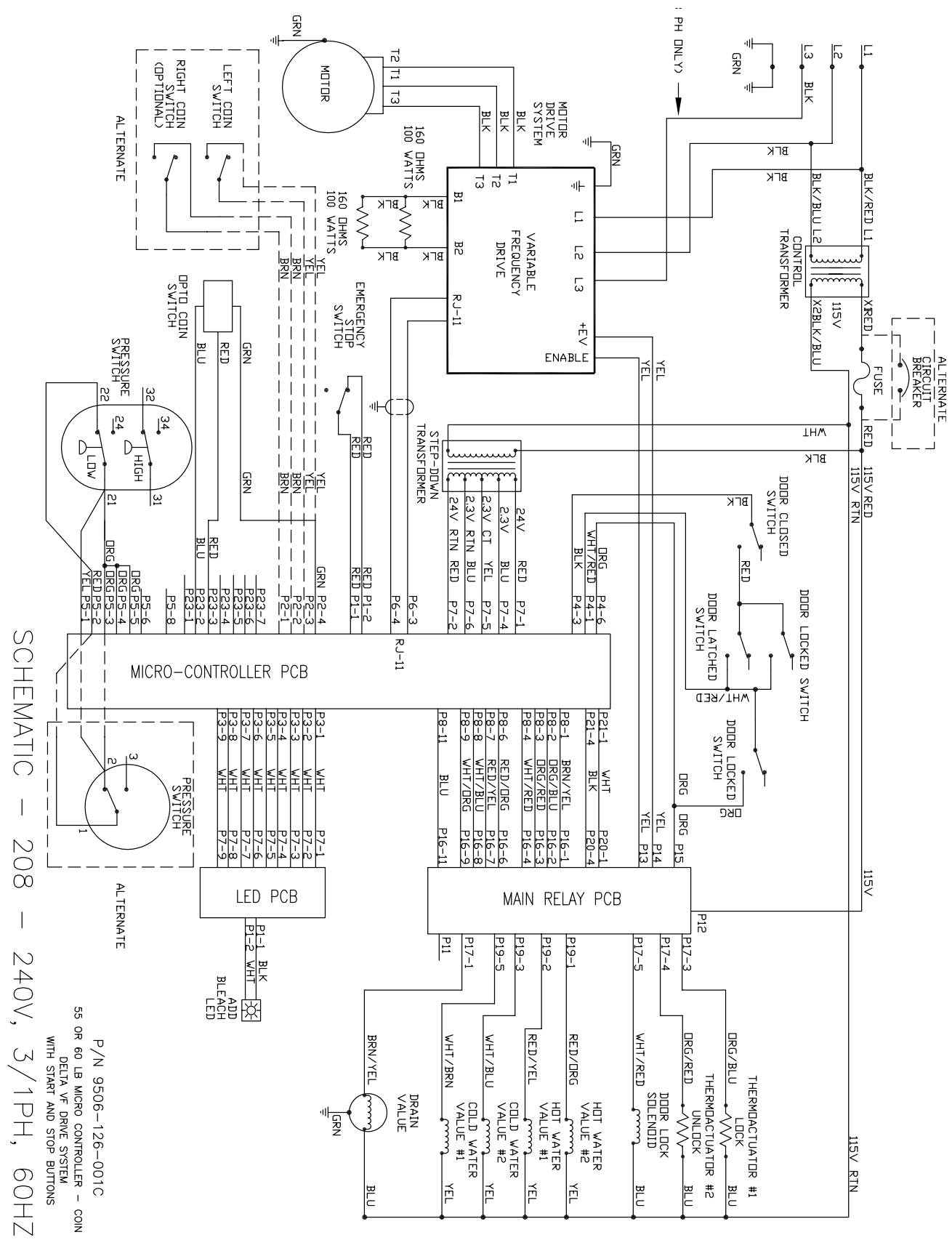

60Lb. Non-Express Coin Micro Switch Diagram

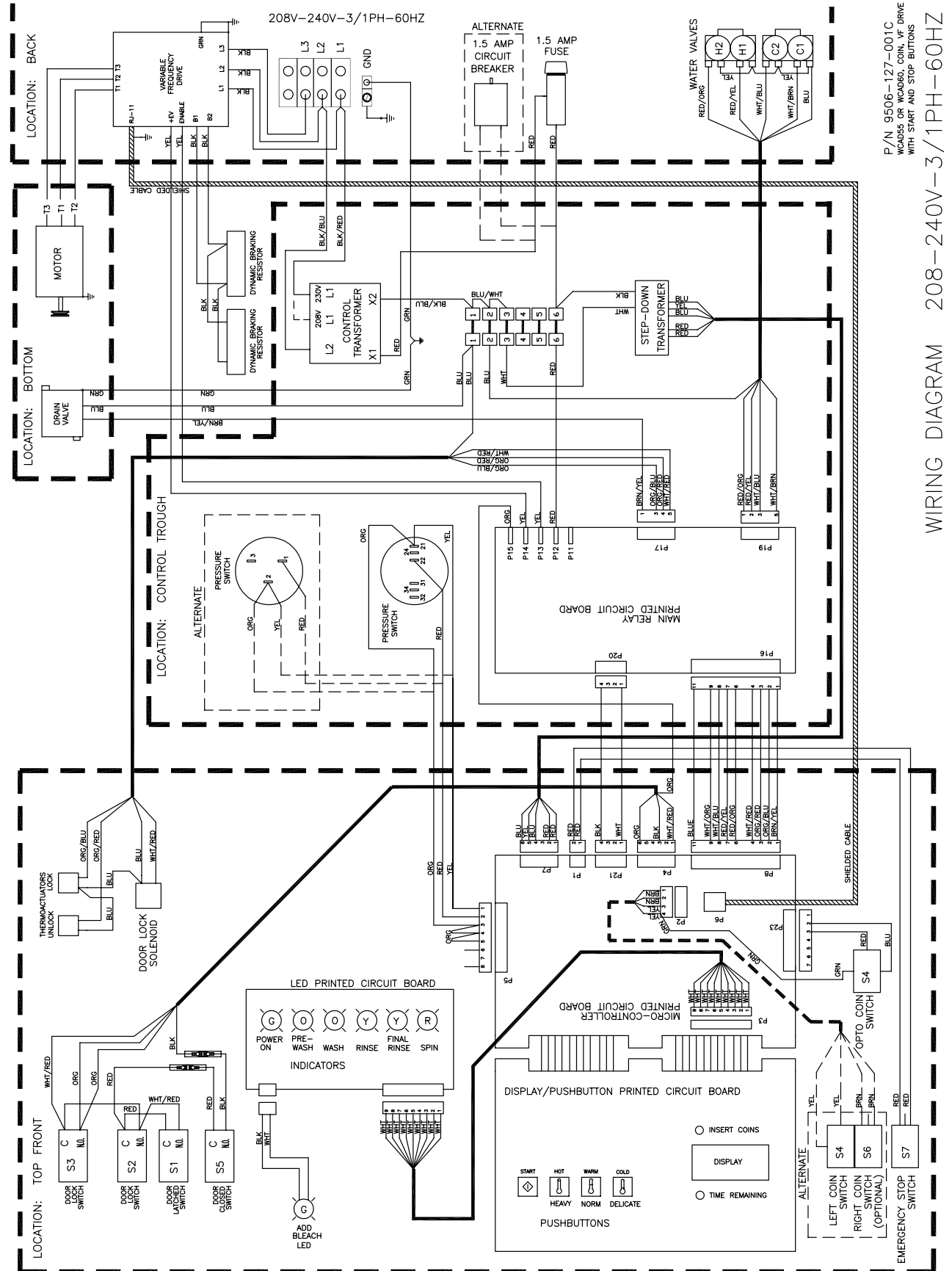

60Lb. Non- Express Electronic Acceptor Schematic 208-240V

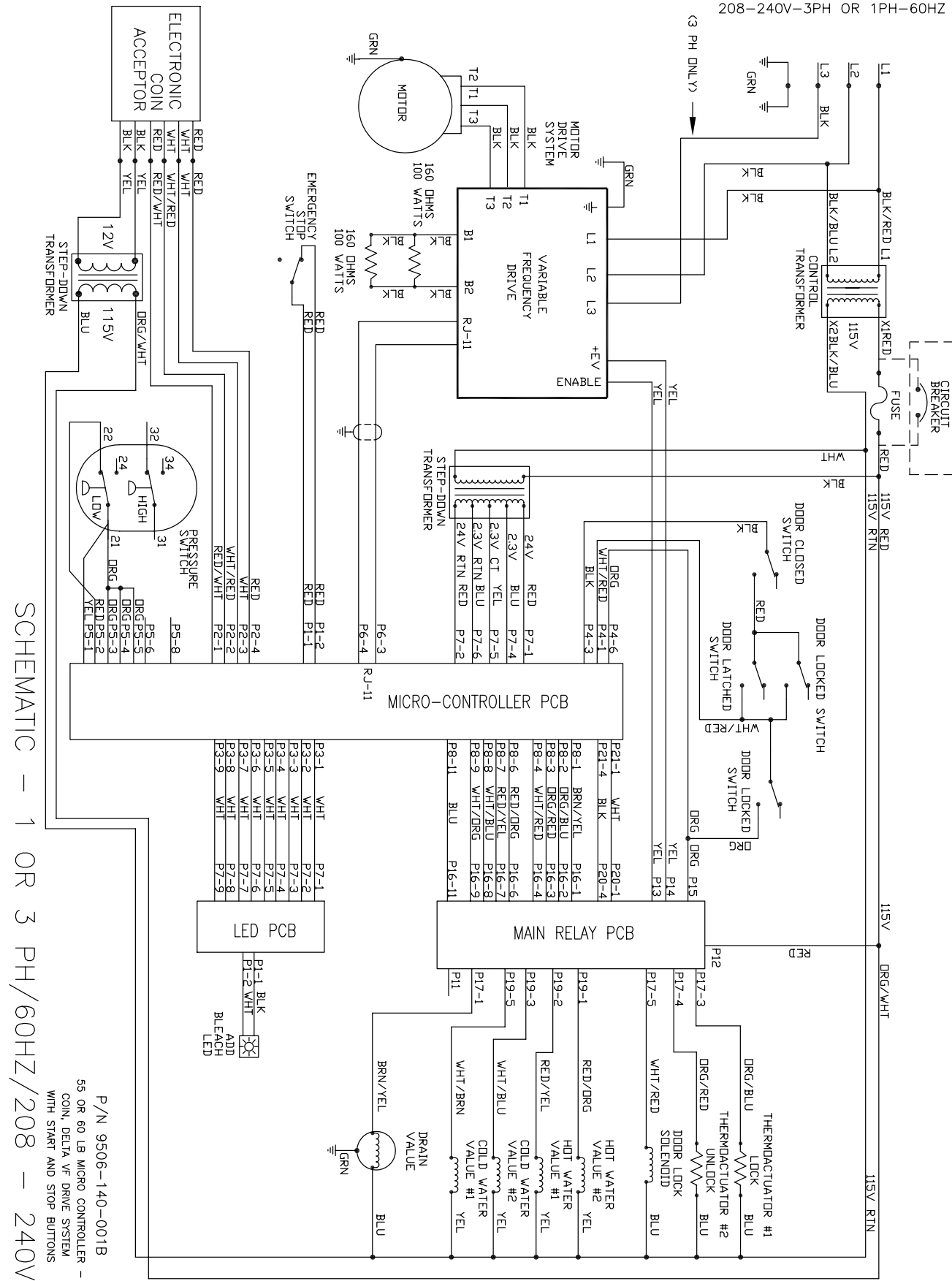

60Lb. Non- Express Electronic Acceptor Diagram 208-240V

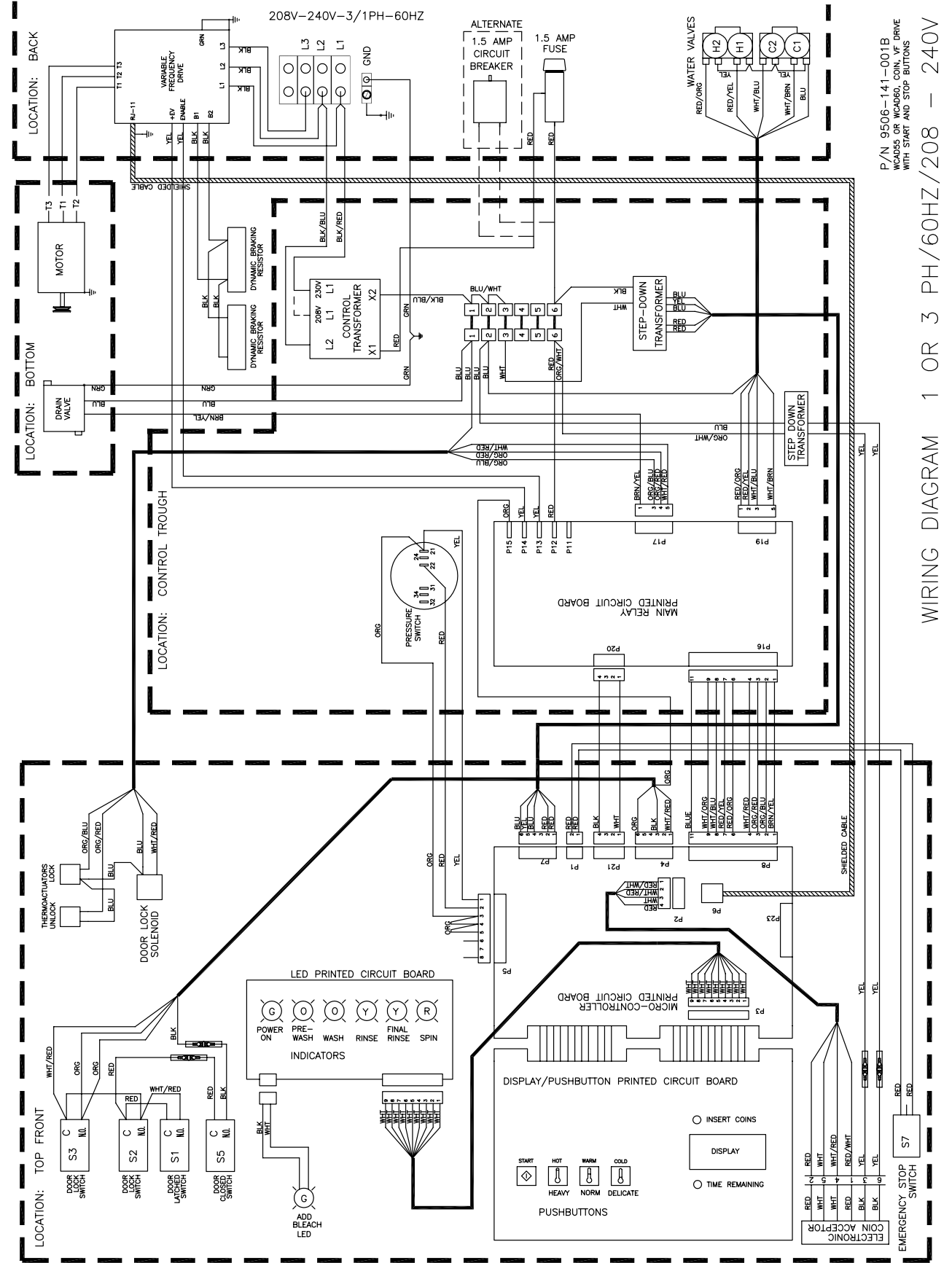

US coin 60lb Express Coin Micro Switch WCAD60KCB-USSZ Schematic

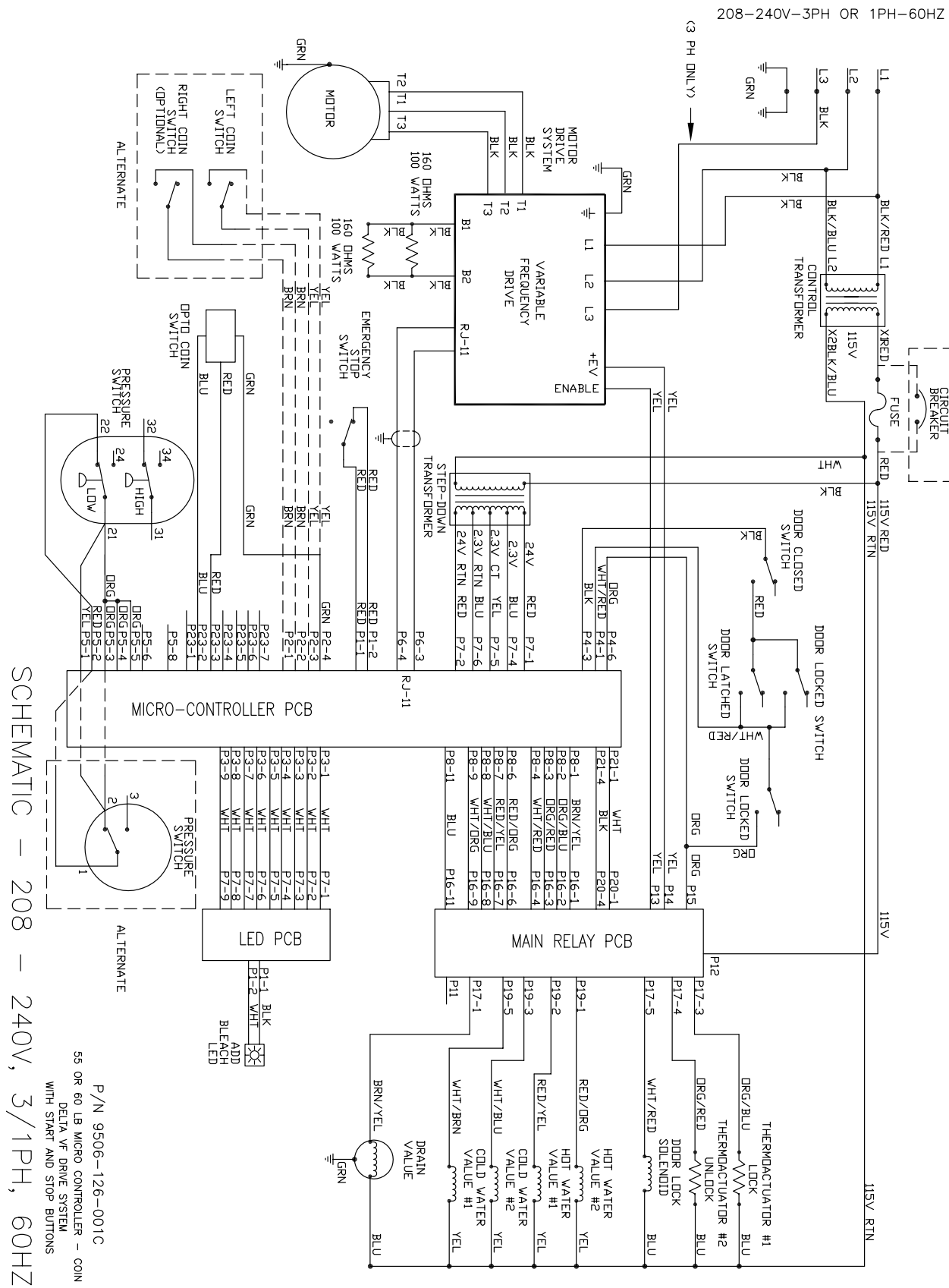

US coin 60lb Express Coin Micro Switch WCAD60KCB-USSZ Diagram

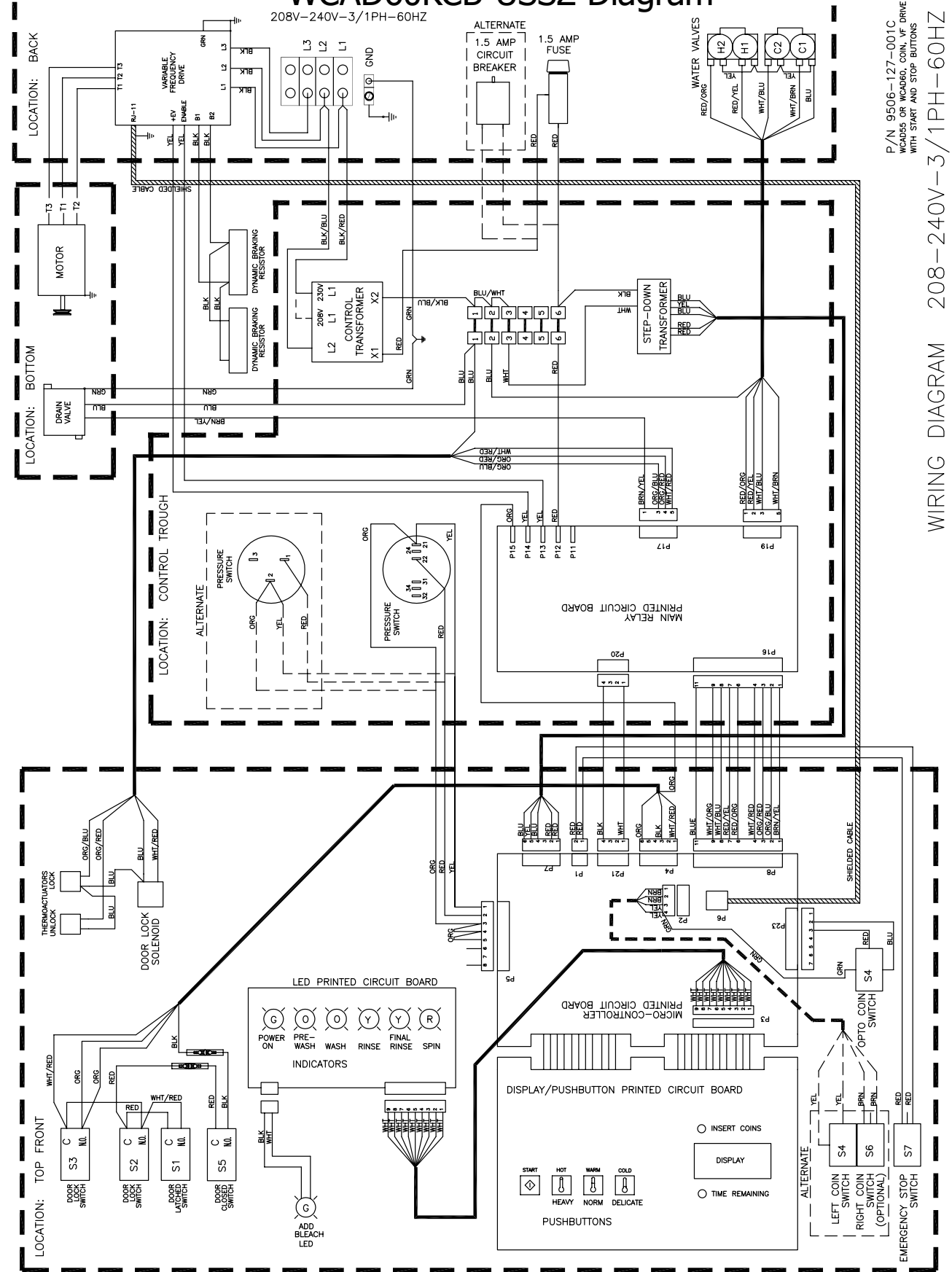

60Lb. Express U.S. Optical Acceptor Schematic 208-240V

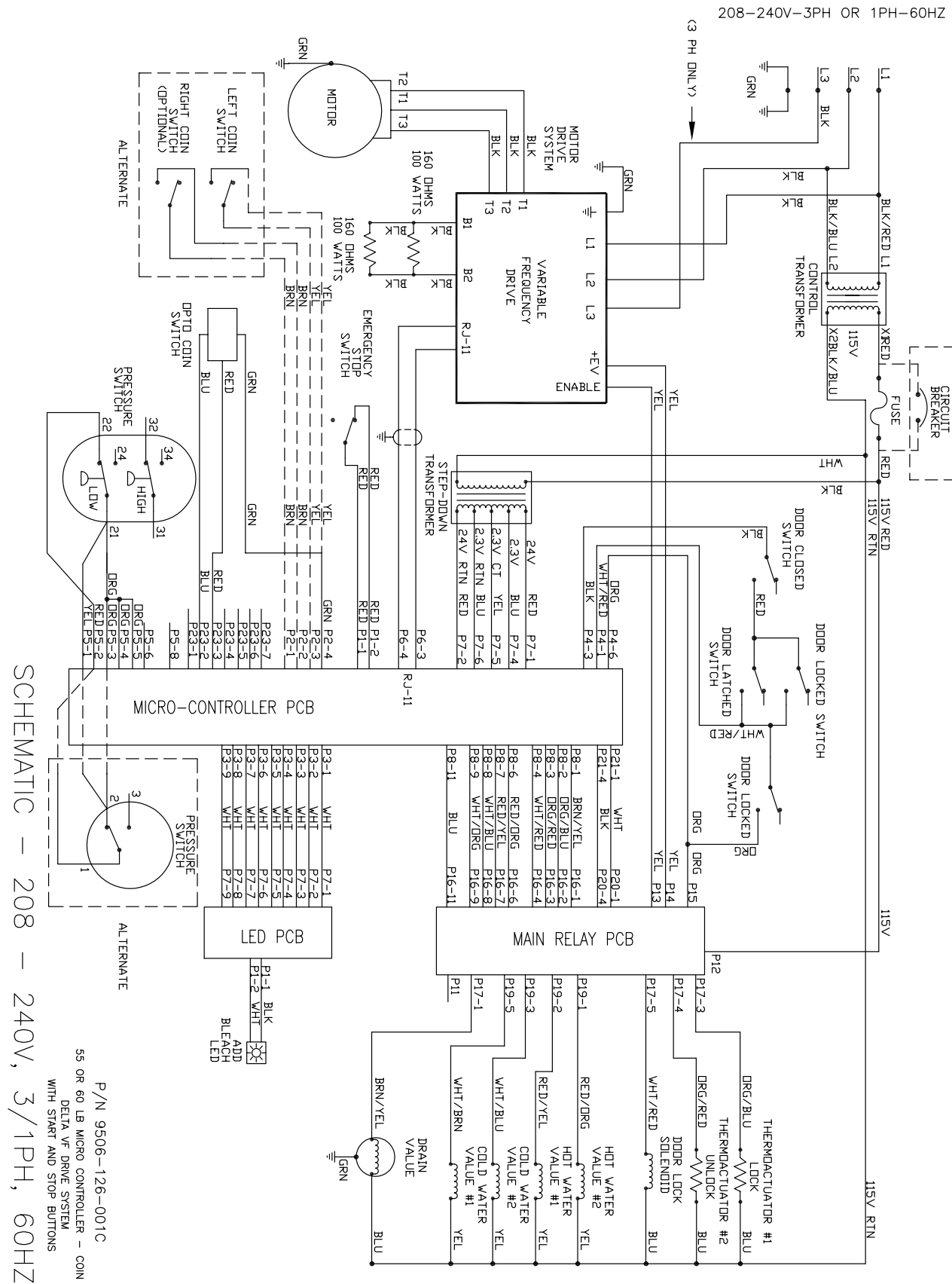

SCHEMATIC - 208 - 240V, 3/1PH, 60HZ

P/N 9506-126-001C
55 OR 60 LB MICRO CONTROLLER - CON
DELTA VF DRIVE SYSTEM
WITH START AND STOP BUTTONS

60Lb. Express U.S. Optical Acceptor Diagram 208-240V

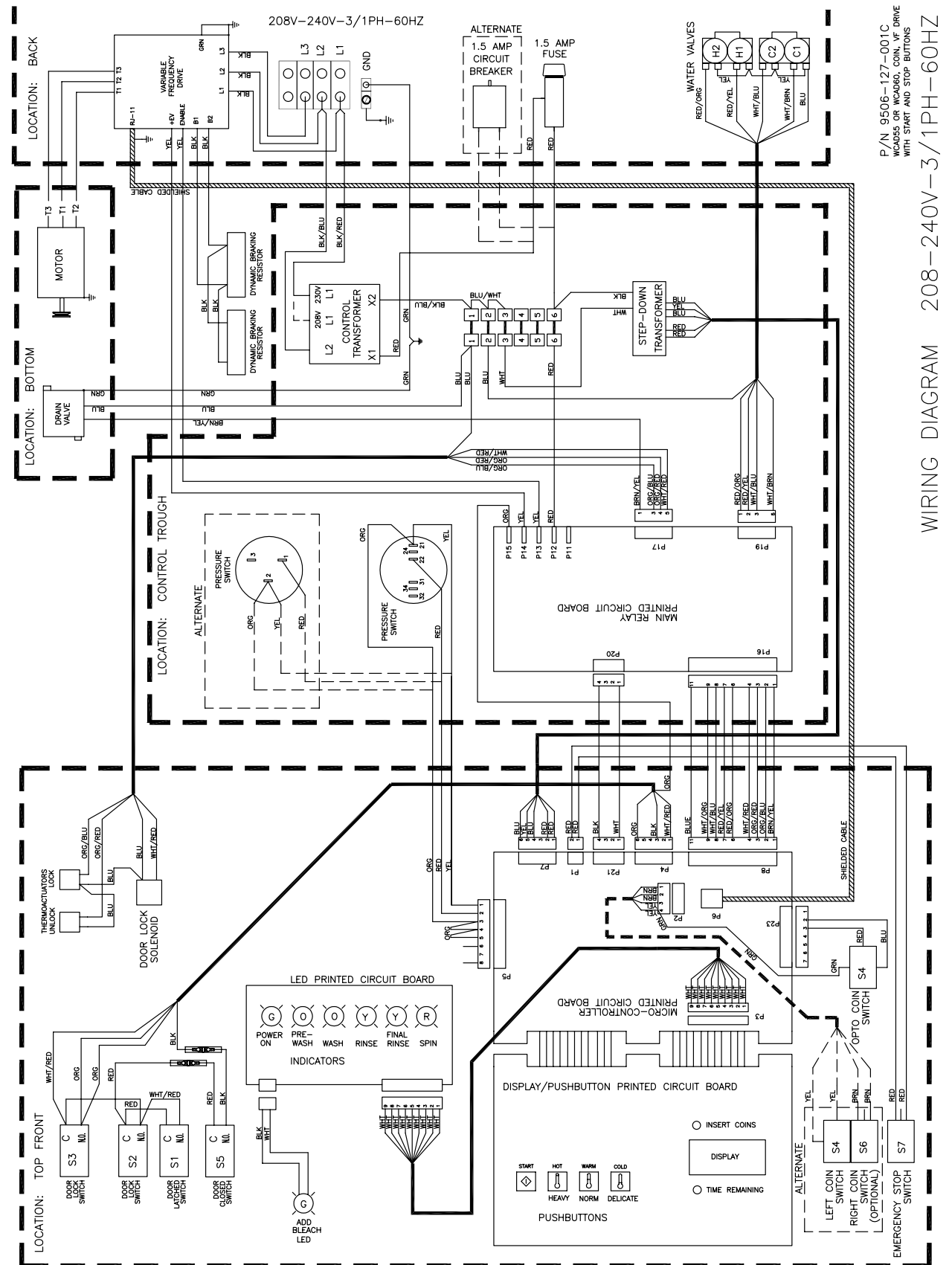

P/N 9506-127-001C
WASDS OR WOODRD, CON, VF DRIVE
WITH START AND STOP BUTTONS

WIRING DIAGRAM 208-240V-3/1PH-60HZ

Coin Micro Switch 80Lb. Non- Express Schematic

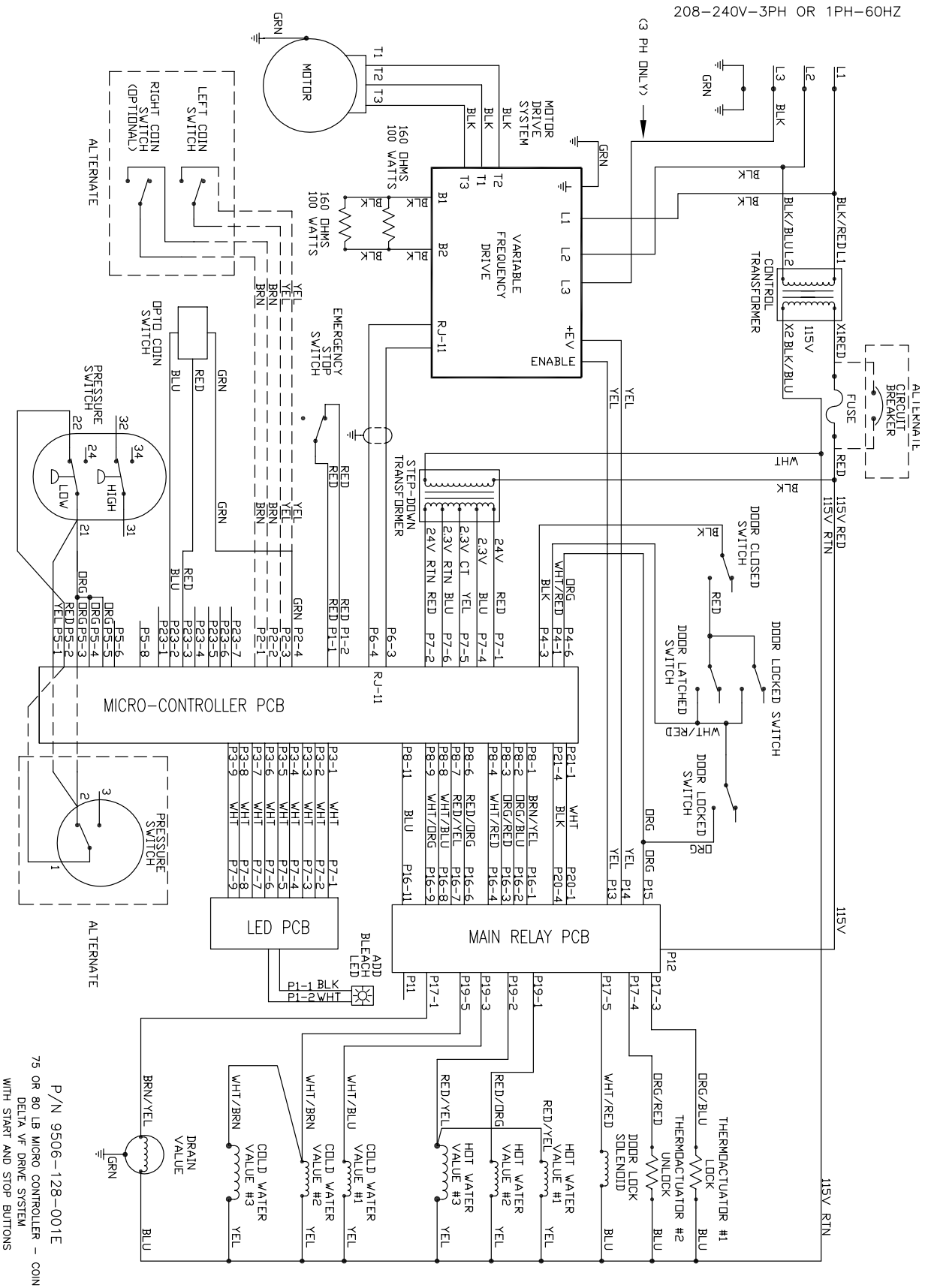

SCHEMATIC - 208 - 240V, 3/1PH, 60HZ

Coin Micro Switch 80Lb. Non- Express Diagram

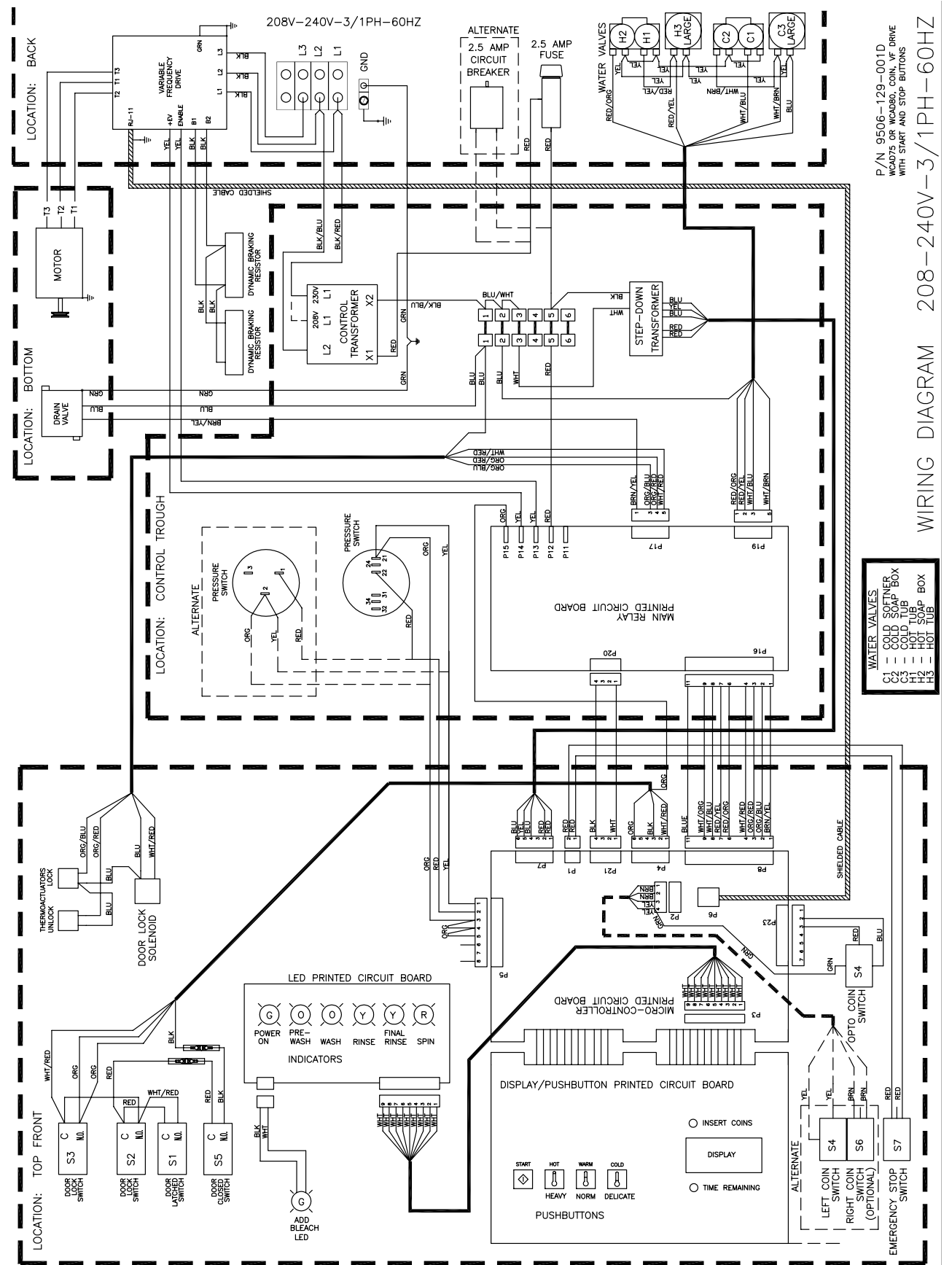

WIRING DIAGRAM 208-240V-3/1PH-60HZ

US coin 80lb WCAD80KCB-US Schematic

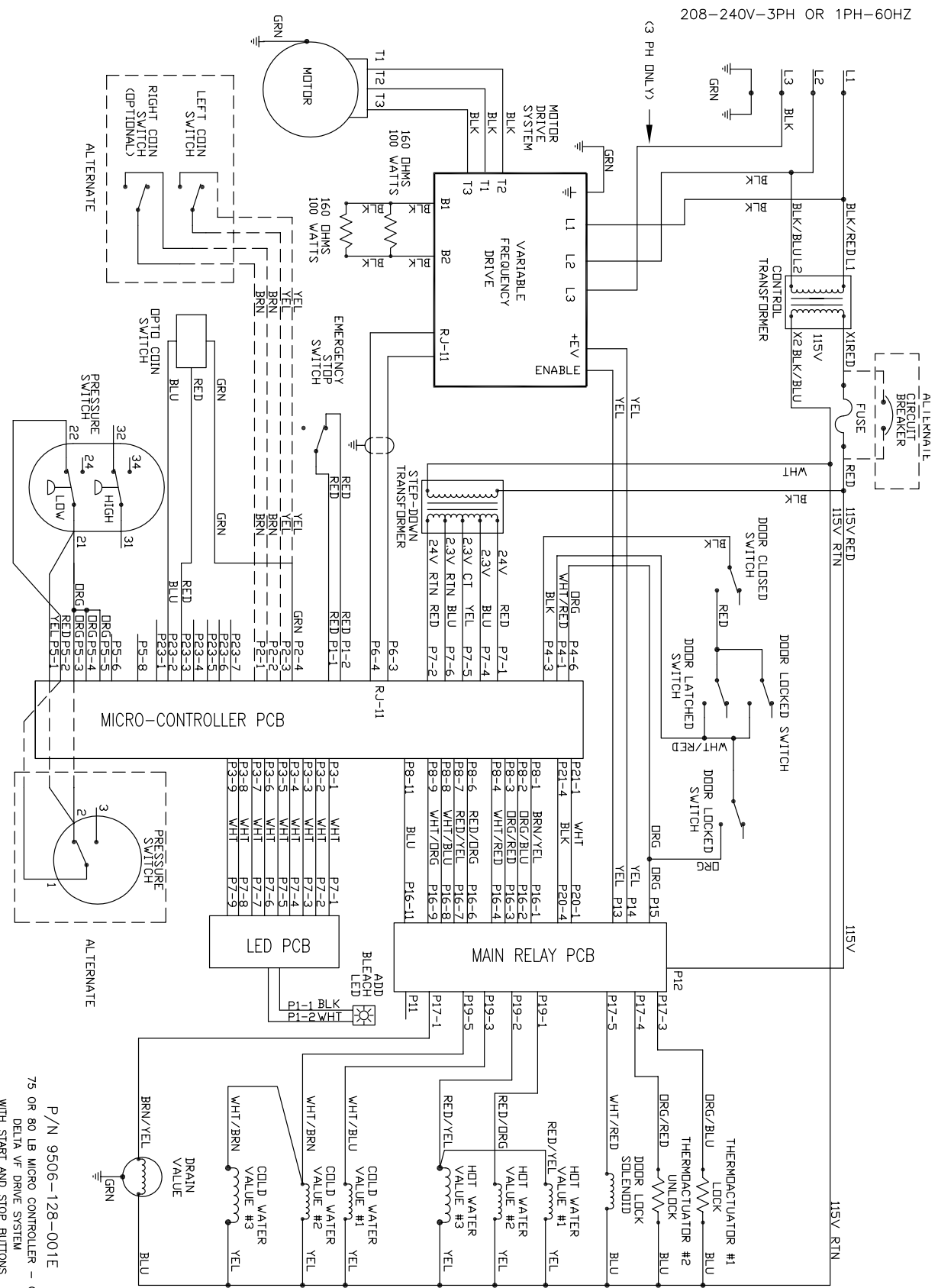

US coin 80lb WCAD80KCB-US Diagram

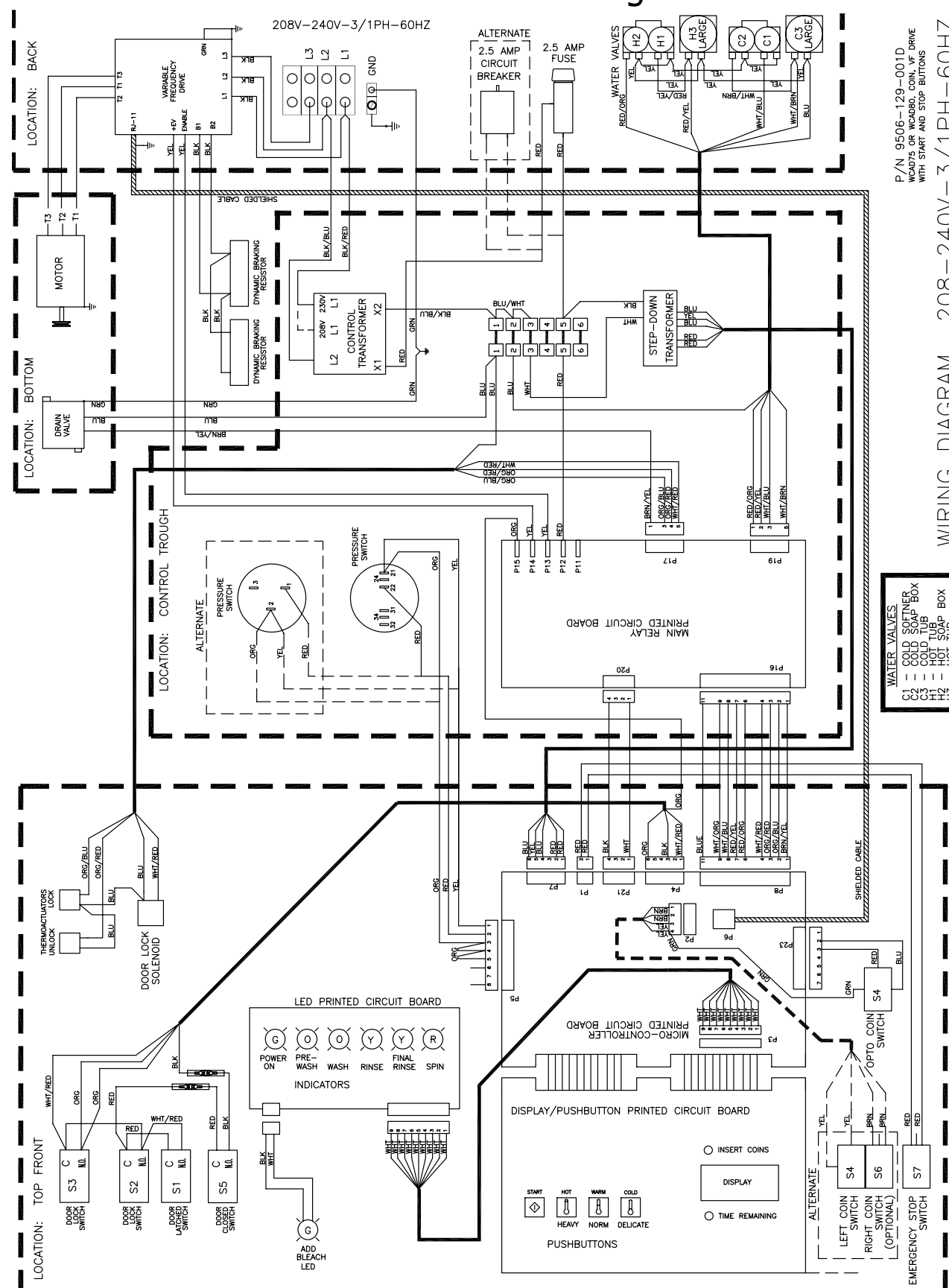

80Lb. Non- Express Electronic Acceptor Schematic 208-240V

208-240V-3PH OR 1PH-60HZ

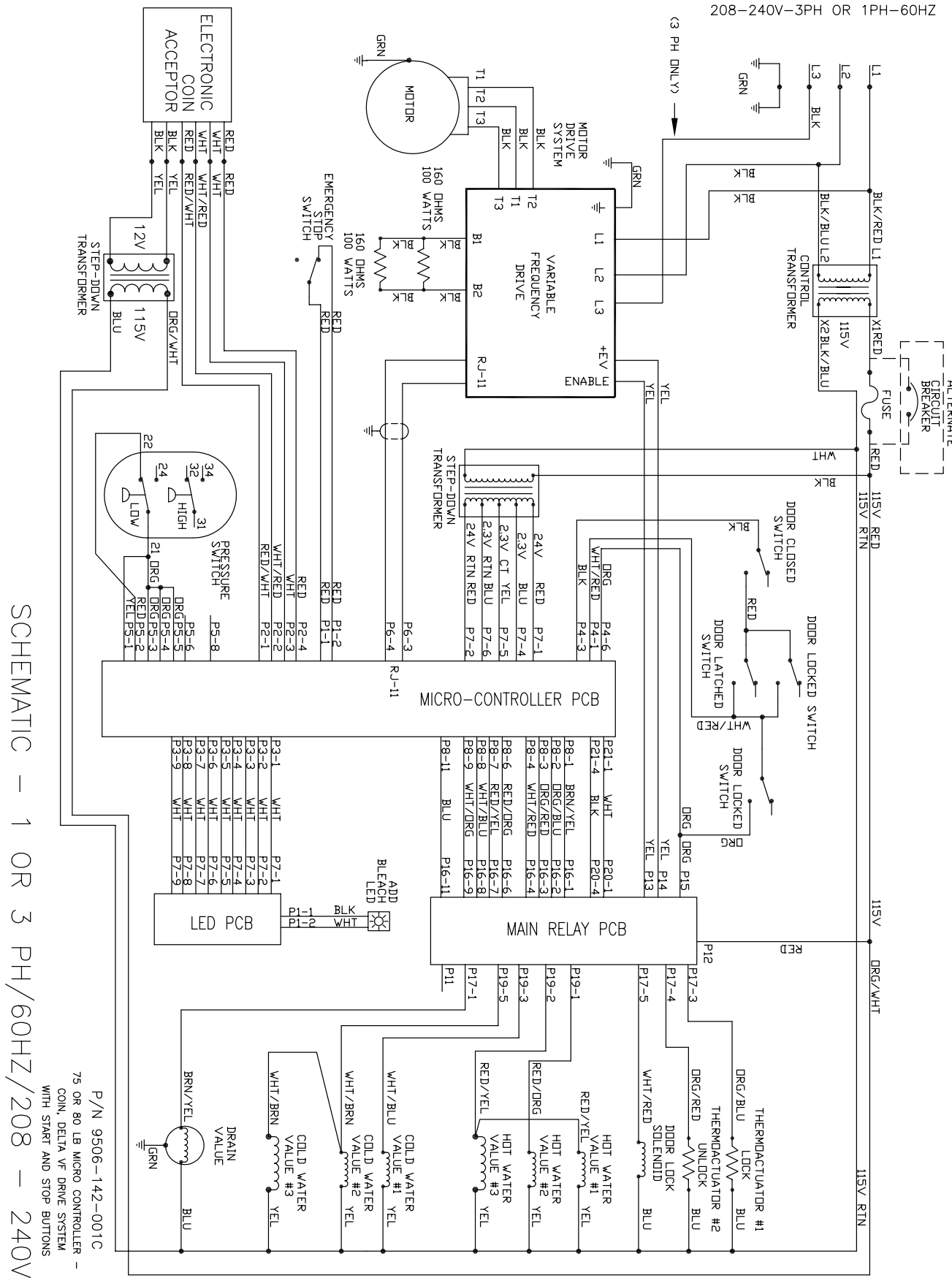

SCHEMATIC - 1 OR 3 PH/60HZ/208 - 240V

80Lb. Non- Express Electronic Acceptor Diagram 208-240V

208V-240V-3/1PH-60HZ

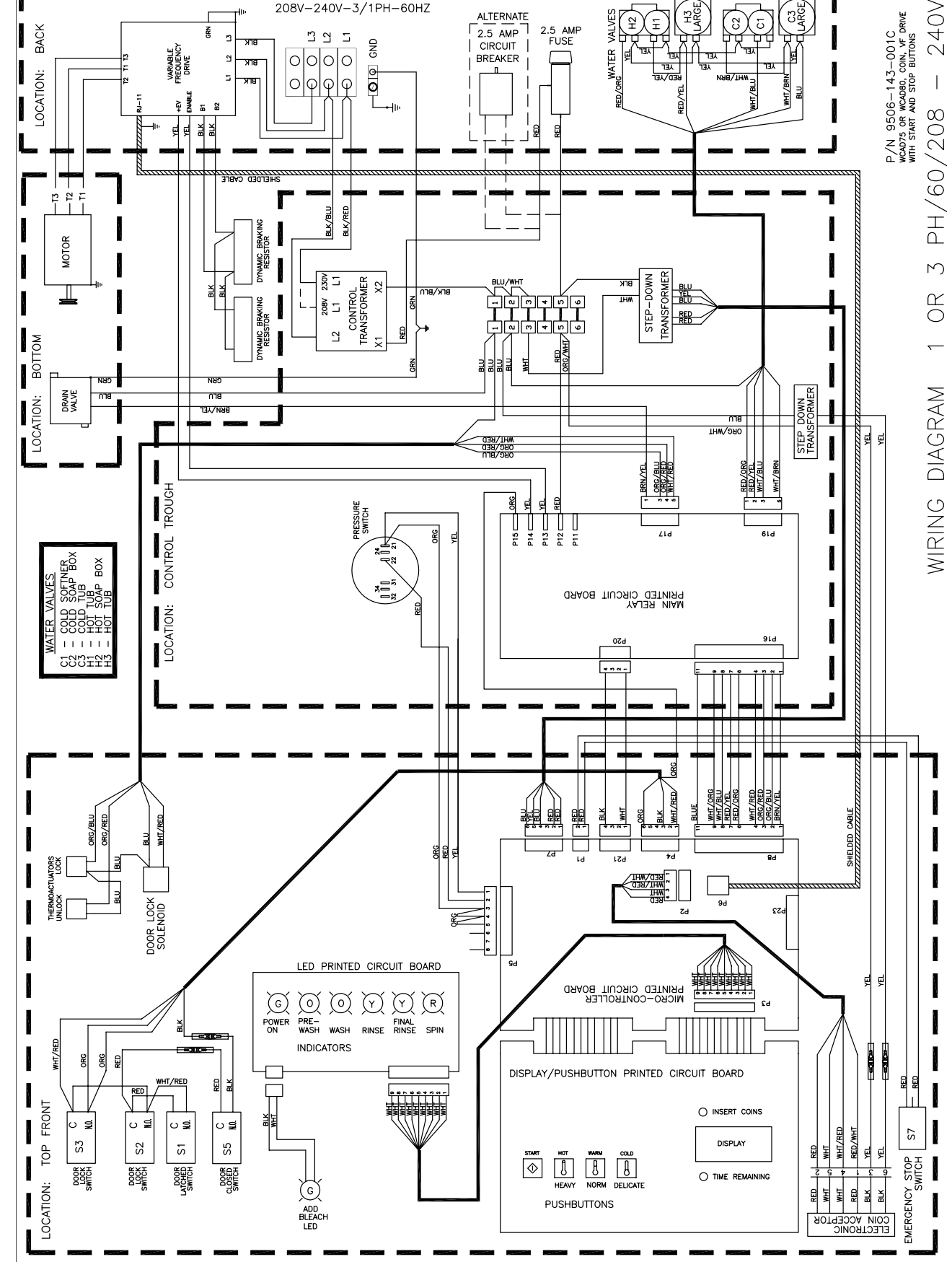

P/N 9506-143-001C
W/75 OR 80 LB MICRO CONTROLLER
WITH START AND STOP BUTTONS

WIRING DIAGRAM 1 OR 3 PH/60/208 - 240V

Integrated Easy Card Control Panel Part # by Model

Key	Description	T-750	T-900	T-950	T-1200	T-1450	QTY
1	Panel Assembly (panel only)	9989-504-001	9989-504-001		9989-504-001	NA	1
*	Screw, Hxwshrhnduct #10Bx 1/2"	9545-008-026	9545-008-026		9545-008-026		4
2	Front Panel	9454-810-002	9454-810-002		9454-810-002		1
*	Post Locator Top	9467-024-001					2
*	Nut Hexkeps #6-32	8640-411-003	8640-411-003		8640-411-003		2
*	Locator Panel	9355-001-001	9355-001-001		9355-001-001		2
*	Screw FillHDCR 10Bx1/2"	9545-008-023	9545-008-023		9545-008-023		2
*	Spacer Pushbutton (Micro)	9538-178-001	9538-178-001		9538-178-001		1
*	Retainer Pushbutton (Micro)	9486-150-001	9486-150-001		9486-150-001		1
*	Nut Hexelasticstop #6-32	8640-411-003	8640-411-003		8640-411-003		2
5	Pushbutton Control (coin)	9035-060-003	9035-060-003		9035-060-003		1
6	PCB assembly Control /Display STOP	9473-009-002	9473-009-002		9473-009-002		1
*	Spacer Plastic #6x9/16	9538-157-018	9538-157-018		9538-157-018		5
*	Nut Elasticstop #6-32	8640-411-002	8640-411-002		8640-411-002		5
*	Harness LEDPCB	9627-797-001	9627-797-001		9627-797-001		1
4	Harness Doorlock	9627-791-003	9627-791-003		9627-791-003		1
7	PCB assembly Mode lights	9473-005-001	9473-005-001		9473-005-001		1
*	Spacer Plastic #6x9/16	9538-157-018	9538-157-018		9538-157-018		2
*	Nut Hexkeps #6-32	8640-411-003	8640-411-003		8640-411-003		2
8	Light, LED,ADD BLEACH Assembly	9794-001-001	9794-001-001		9794-001-001		1
*	Spacer Plastic #6x9/16	9538-157-018	9538-157-018		9538-157-018		2
*	Nut Hexeps #6-32	8640-411-003	8640-411-003		8640-411-003		2
9	Nameplate,Control Panel (one piece)	9412-144-001	9412-158-001		9412-146-001		1
10	Switch Assembly Emergency Stop	9732-223-001	9732-223-001		9732-223-001		1
11	Solenoid Ass'y, Door Locking (see Door Lock Group for parts breakdown)	9922-011-001	9922-011-001		9922-011-001		1
16	Hex Nuts (mounting solenoid assy. to control panel)	8640-412-005	8640-412-005		8640-412-005		3
12	Battery	8612-001-001	8612-001-001		8612-001-001		1
13	Harness V-reader ALL MODELS	9627-827-001	9627-827-001		9627-827-001		1
14	Card Reader Assembly Complete	9797-007-003	9797-007-003		9797-007-003		1
15	Cable Assembly 4 twisted pair 12' shld/unshld reader to rear of machine	9806-013-002	9806-013-002		9806-013-002		1
*	Mounting plate for card reader	9982-337-001	9982-337-001		9982-337-001		1

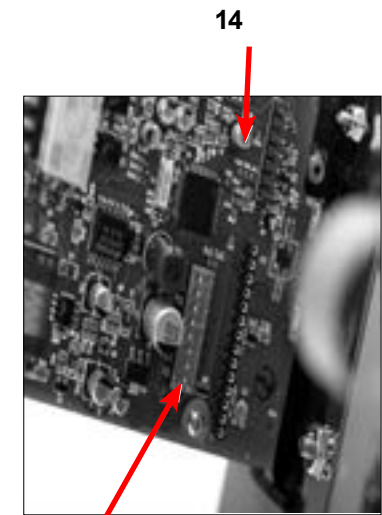
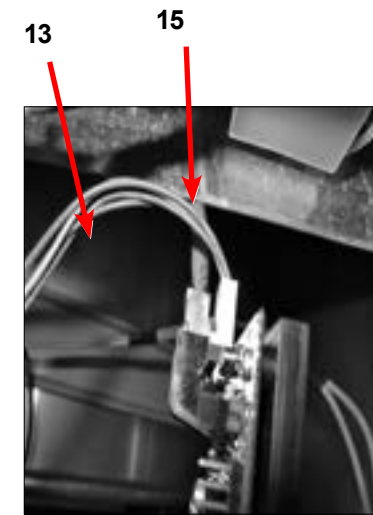

Reader Wire Harness Connection

Address Switch

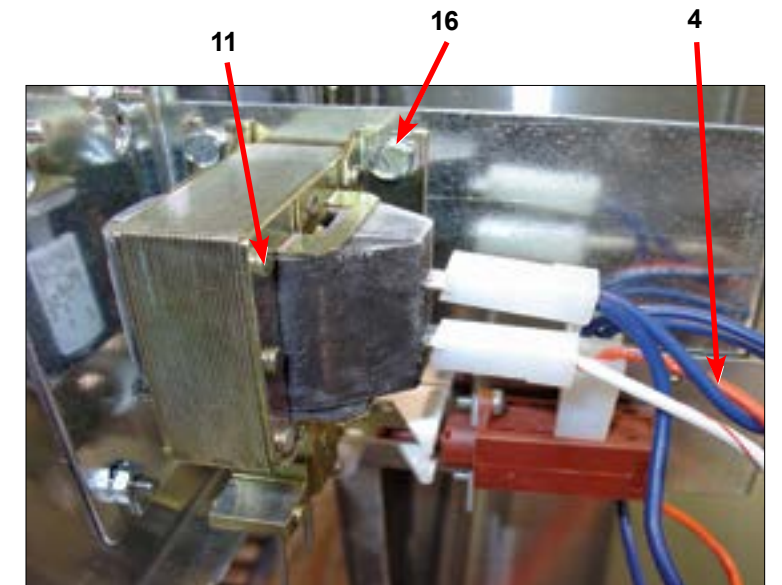
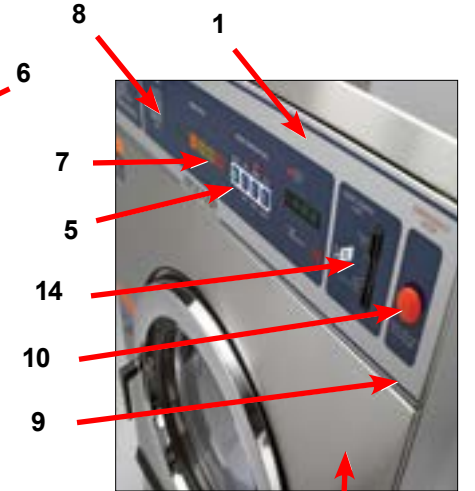
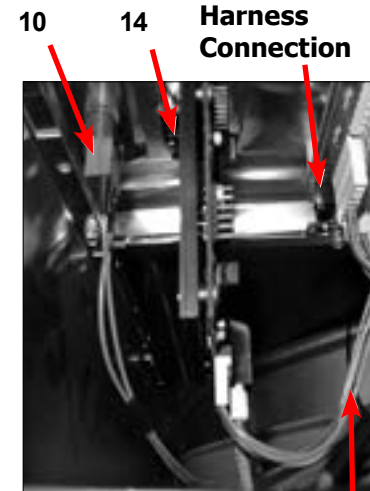

Converted Easy Card 50Lb. Express 208-240 Volt Wiring Schematic

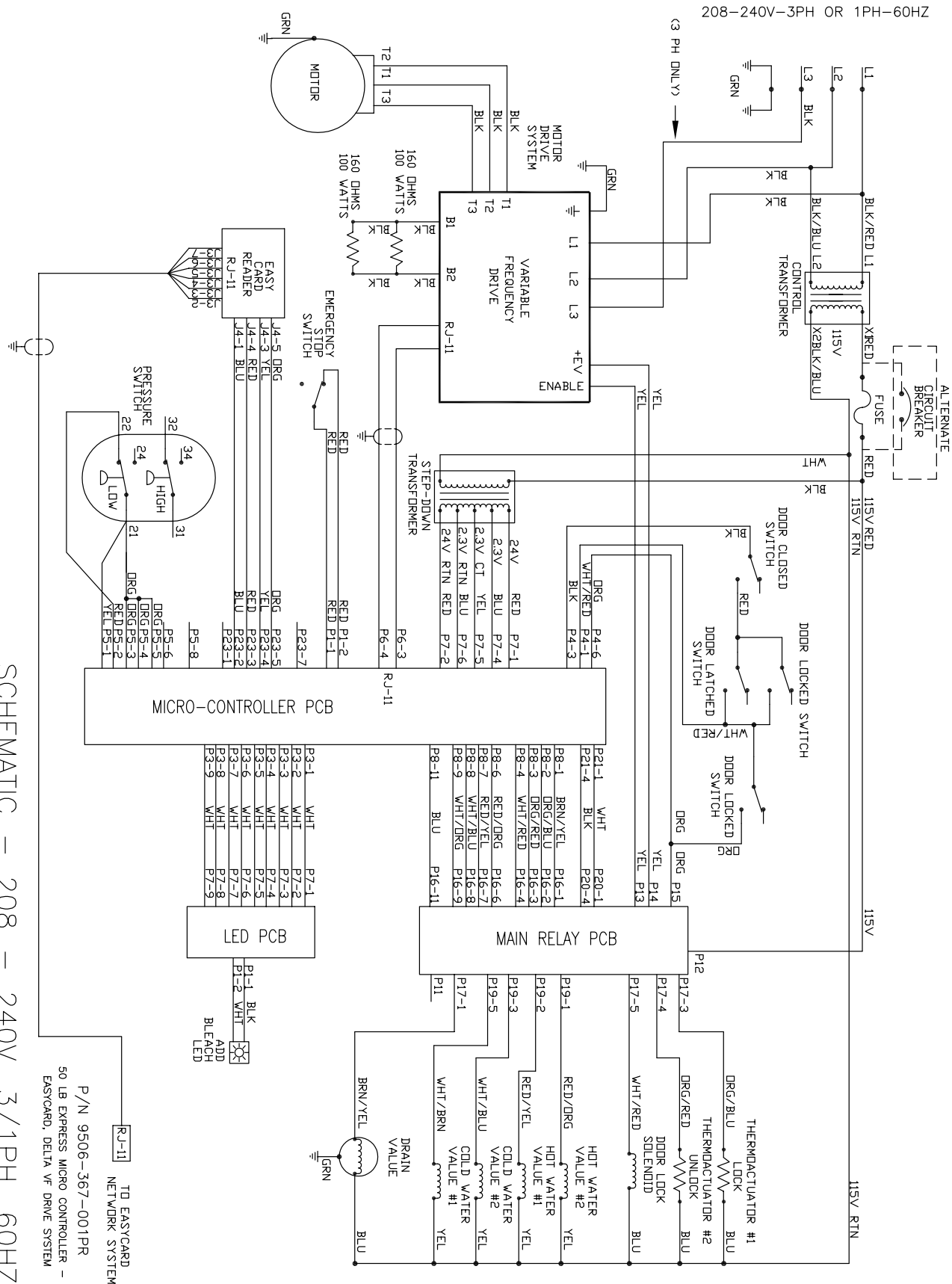

SCHEMATIC - 208 - 240V, 3/1PH, 60HZ

Converted Easy Card 50Lb. Express 208-240 Volt Wiring Diagram

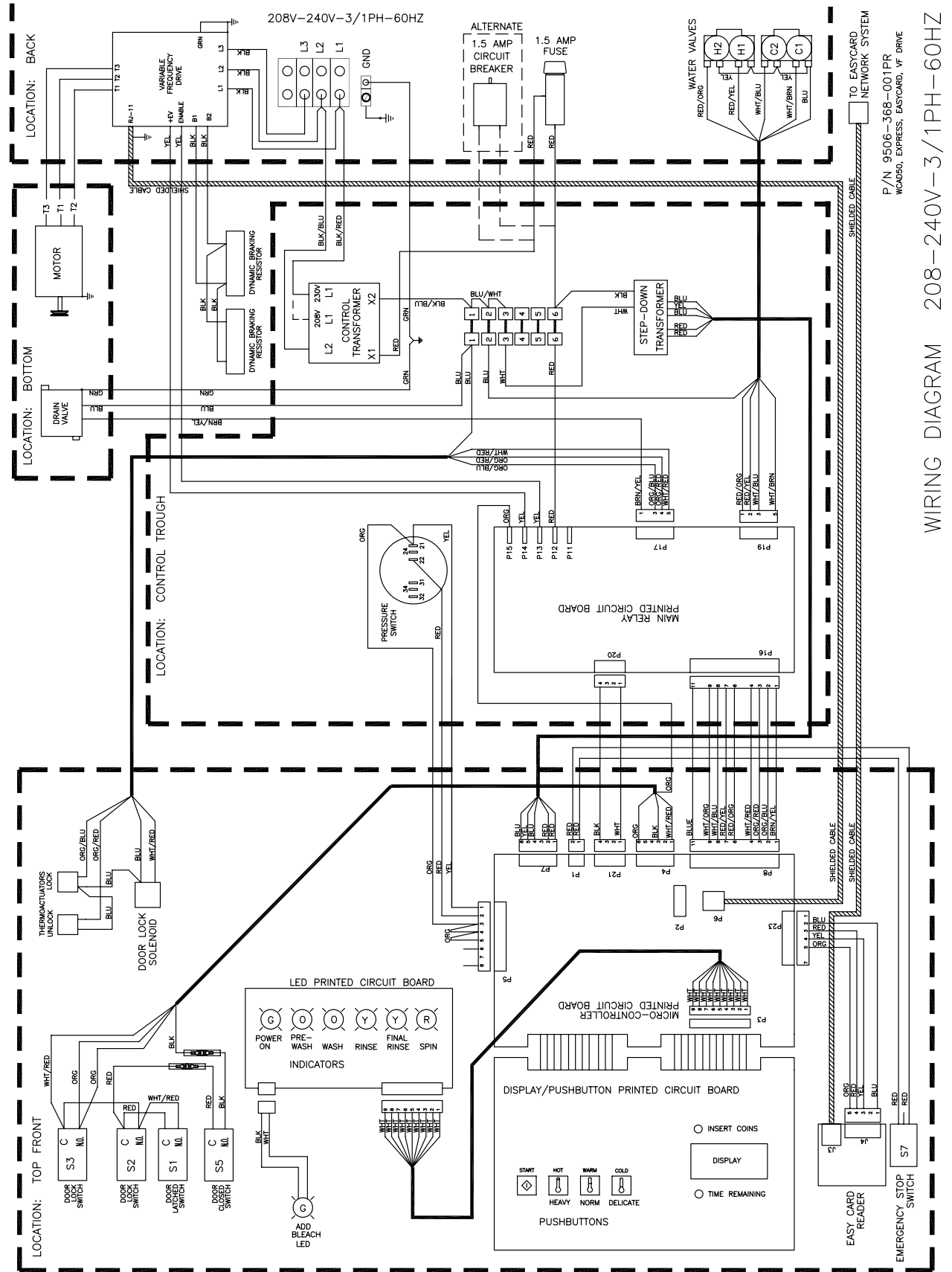

WIRING DIAGRAM 208-240V-3/1PH-60HZ
P/N 9506-368-001 PR
W4060, EXPRESS, EASYCARD, VF DRIVE

Converted Easy Card 60Lb. Non-Express 208-240 Volt Wiring Schematic

208-240V-3PH OR 1PH-60HZ

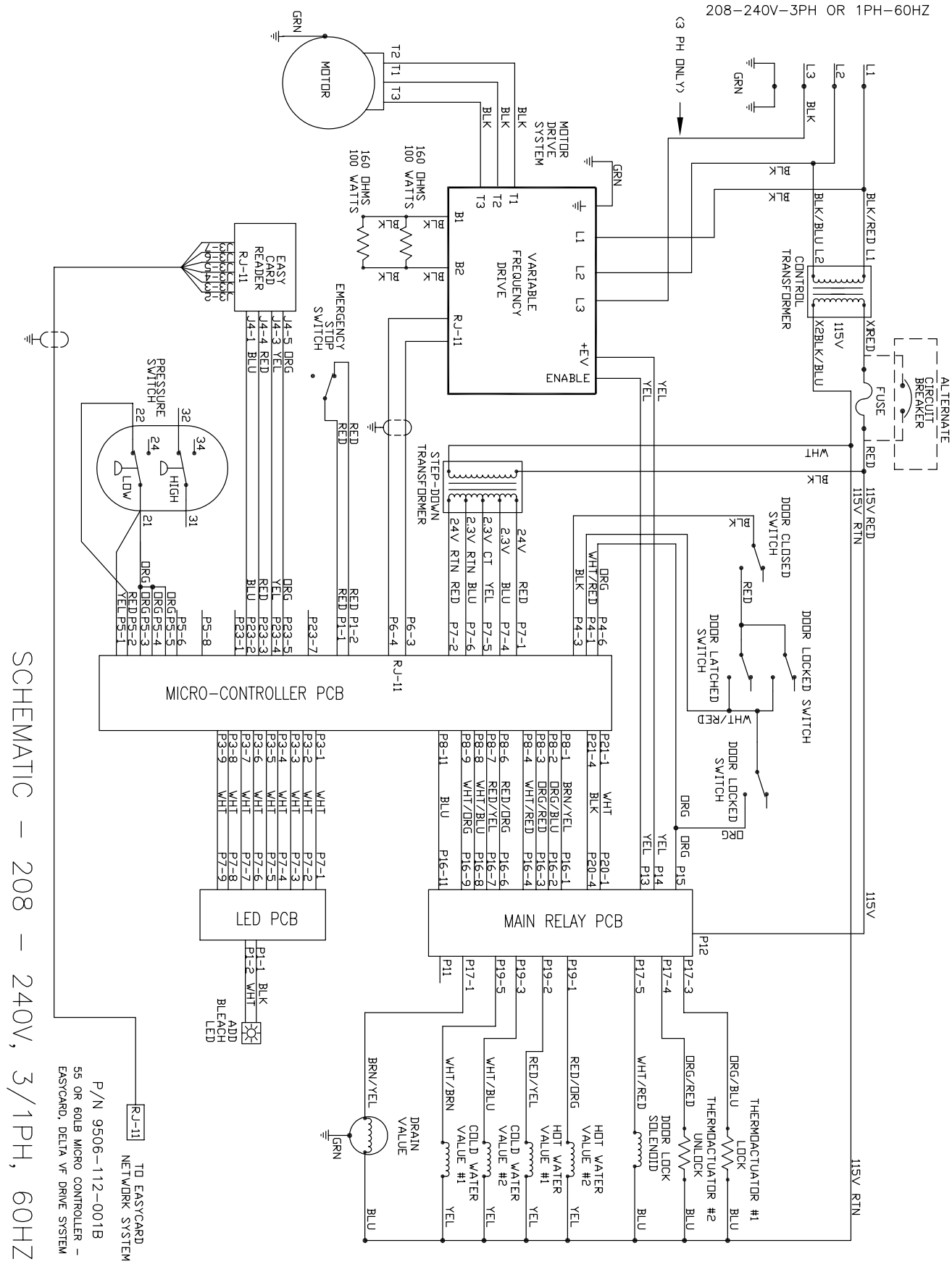

SCHEMATIC - 208 - 240V, 3/1PH, 60HZ

P/N 9506-112-001B
55 OR 60LB MICRO CONTROLLER -
EASycARD, DELTA VF DRIVE SYSTEM

Converted Easy Card 60Lb. Non-Express 208-240 Volt Wiring Diagram

208V-240V-3/1PH-60HZ

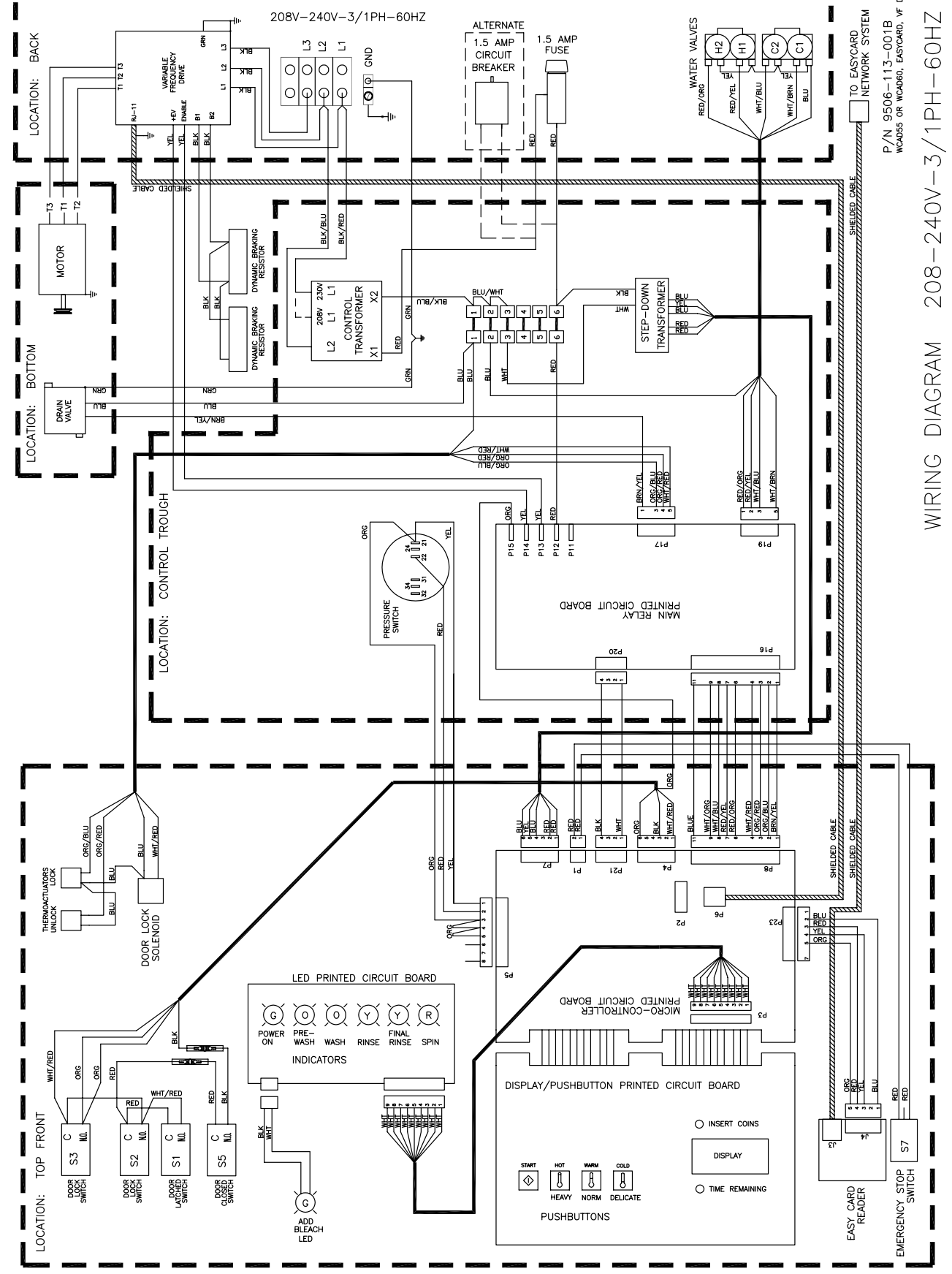

P/N 9506-113-001B
W4D55 OR W4D60, EASycARD, VF DRIVE

WIRING DIAGRAM 208-240V-3/1PH-60HZ

Transformer, Electrical Filter and Coin Handling -59 models

Key	Component	T-750	T-900	T-950	T-1200	T-1450	QTY
1	Circuit Breaker	5198-211-002	5198-211-002		5198-211-002		1
*	Wire Assembly Black / Red	8220-001-232	8220-001-232		8220-061-003		1
*	Wire Assembly Black / Blue	8220-001-233	8220-001-233		8220-061-004		1
*	Wire Assembly Red	8220-001-282	8220-001-282		8220-001-282		1
*	Wire Assembly Black / Blue	8220-065-007	8220-065-007		8220-065-007		1
*	Wire Assembly Red	8220-065-011	8220-065-011		8220-065-011		1
*	Instructions, Transformer Connect	8507-230-003	8507-230-003		8507-230-003		1
*	Owners Booklet	8514-116-001	8514-116-001		8514-120-001		1
*	Nut #8-32	8640-412-005	8640-412-005		8640-412-005		13
*	Nut #10-32	8640-413-002	8640-413-002		8640-413-002		28
*	Lockwasher - Extooth #6	8641-582-005	8641-582-005		8641-582-005		2
2	Controls Transformer	8711-008-002	8711-008-002		8711-008-002		1
3	Transformer	8711-009-003	8711-009-003		8711-009-003		1
4	Coin Acceptor - Electronic	9021-011-001	9021-011-001		9021-011-001		1
5	Harness - Electronic Coin Acceptor	9627-845-001	9627-845-001		9627-845-001		1
*	Bracket Terminal/Filter Mounting	9029-188-001	9029-188-001		9029-170-001		1
*	Standoff, Twistloc				9527-002-002		6
*	Rear Channel 18lb OPL	9081-132-002	9081-132-002				1
6	EMI Line Filter	9183-030-003	9183-030-003				1
7	EMI Filter 1 ph, 20 Amp	9183-040-001	9183-040-001		9183-040-001		1

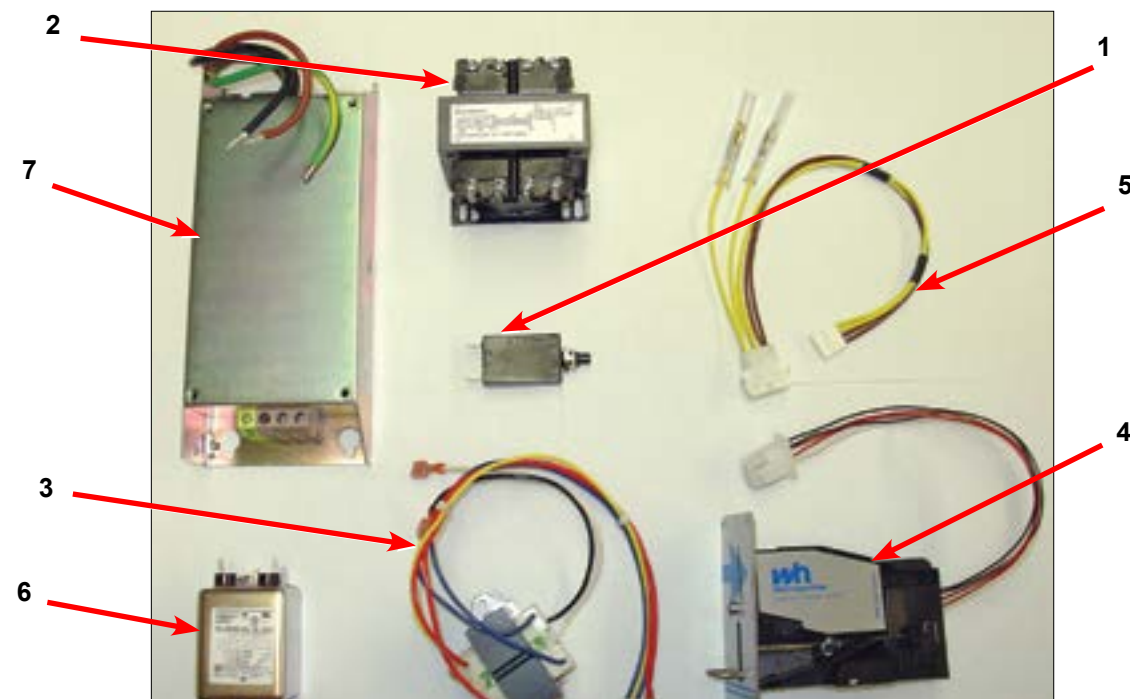

Water Valve, Drain Valve and Door Locking -59 models

Key	Component	T-750	T-900	T-950	T-1200	T-1450	QTY
1	Water Valve	9379-183-013	9379-183-013		9379-183-013		2
3	Drain Valve 3" inch	9379-202-002	9379-202-002		9379-202-002		1
*	Filter Mounting Plate	9452-758-001	9452-758-001		9452-747-001		1
*	Wiring Label , Schematic	9506-263-001	9506-265-001		9506-271-001		1
*	Wiring Label , Diagram	9506-264-001	9506-266-001		9506-272-001		1
5	Solenoid, Door Lock	9536-082-001	9536-082-001		9536-082-001		1
*	Screw #10B - 32 X 1/2	9545-008-026	9545-008-026				52
*	Screw #10-32 TT X1/2	9545-008-027	9545-008-027		9545-008-027		3
*	Screw #8-32 X3/8	9545-010-006	9545-010-006		9545-010-006		2
*	Screw Hex 8B X1/4	9545-045-001	9545-045-001		9545-045-001		4
*	Terminal Strip Marker	9558-029-004	9558-029-004				1
6	Thermoactuator, 24V	9586-001-003	9586-001-003		9586-001-003		2
*	Wiring Harness, Power Terminal Block	9627-865-001	9627-865-001		9627-865-002		1
*	Controls Assembly - Trough,	9857-150-005	9857-150-005		9857-151-009		1
*	Door Lock Solenoid Assembly	9922-011-005	9922-011-005		9922-011-005		1
*	Filter Mounting Plate Assembly	9982-359-001	9982-359-001		9982-349-001		1
*	Nut #6-32						4
*	EMI Filter 1 ph, 20 Amp	9183-040-001	9183-040-001		9183-040-001		1
*	Filter Mounting Plate Assembly	9982-359-001	9982-359-001		9982-349-001		1
*	Nut #6-32						4

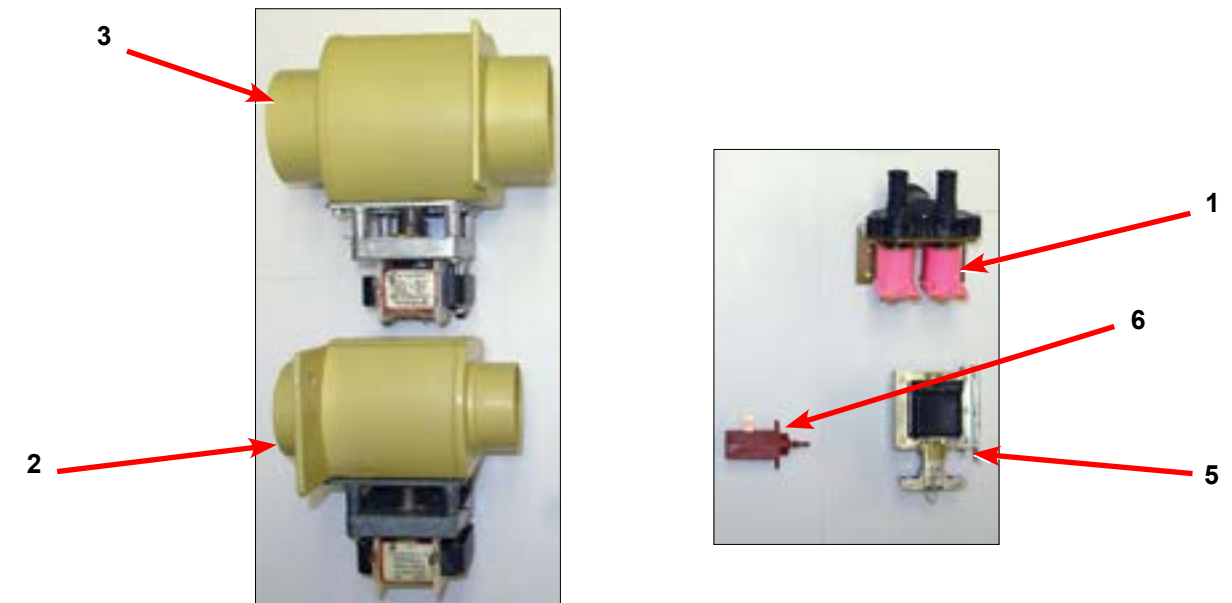

WCAD50KCB -21CNSZ 230/50/1 Voltage Schematic

230V-1PH-50HZ

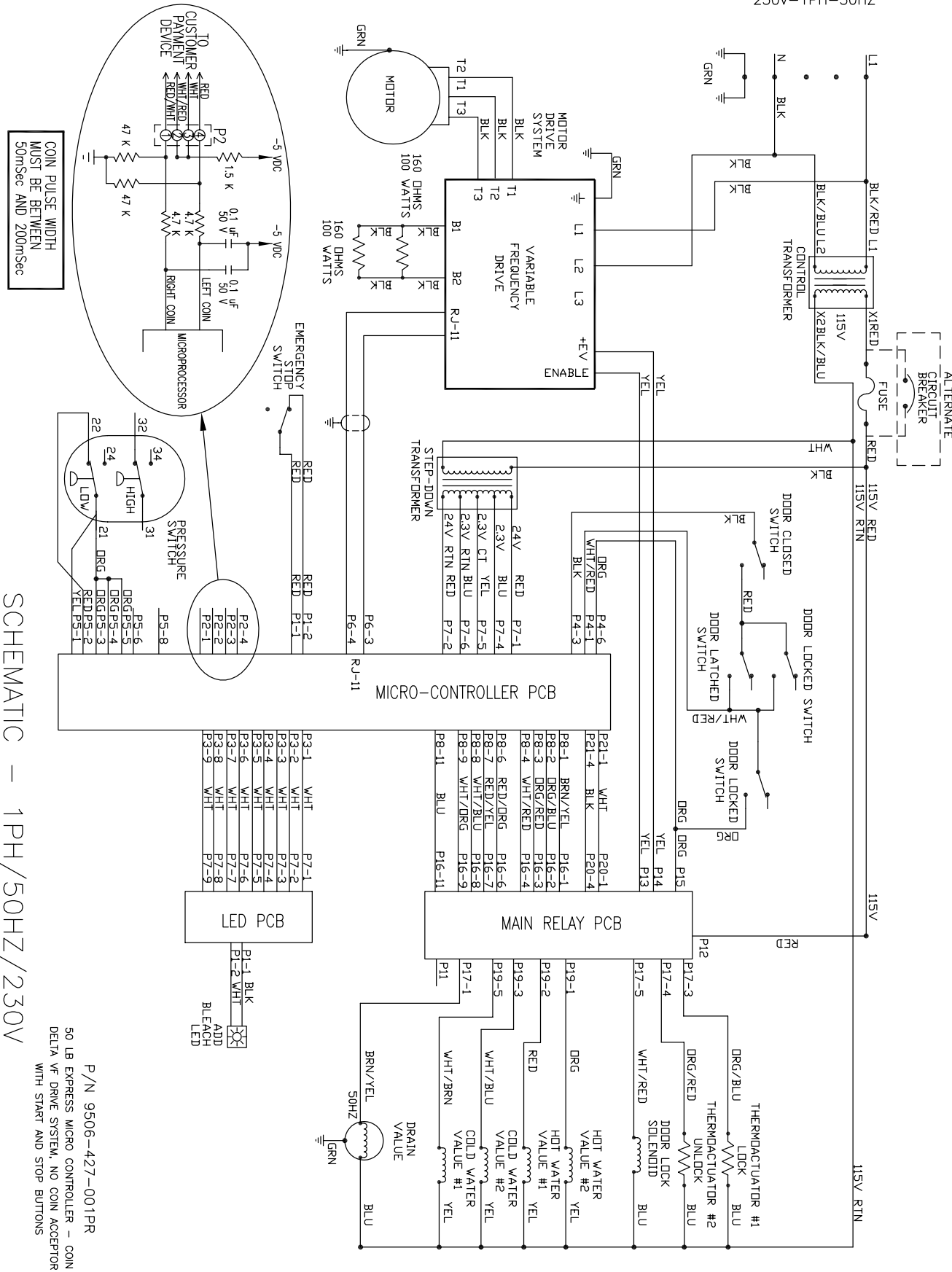

SCHEMATIC - 1PH/50HZ/230V

P/N 9506-427-001PR
50 LB EXPRESS MICRO CONTROLLER - COIN DELTA VF DRIVE SYSTEM, NO COIN ACCEPTOR WITH START AND STOP BUTTONS

WCAD50KCB -21CNSZ 230/50/1 Voltage Diagram

230V-1PH-50HZ

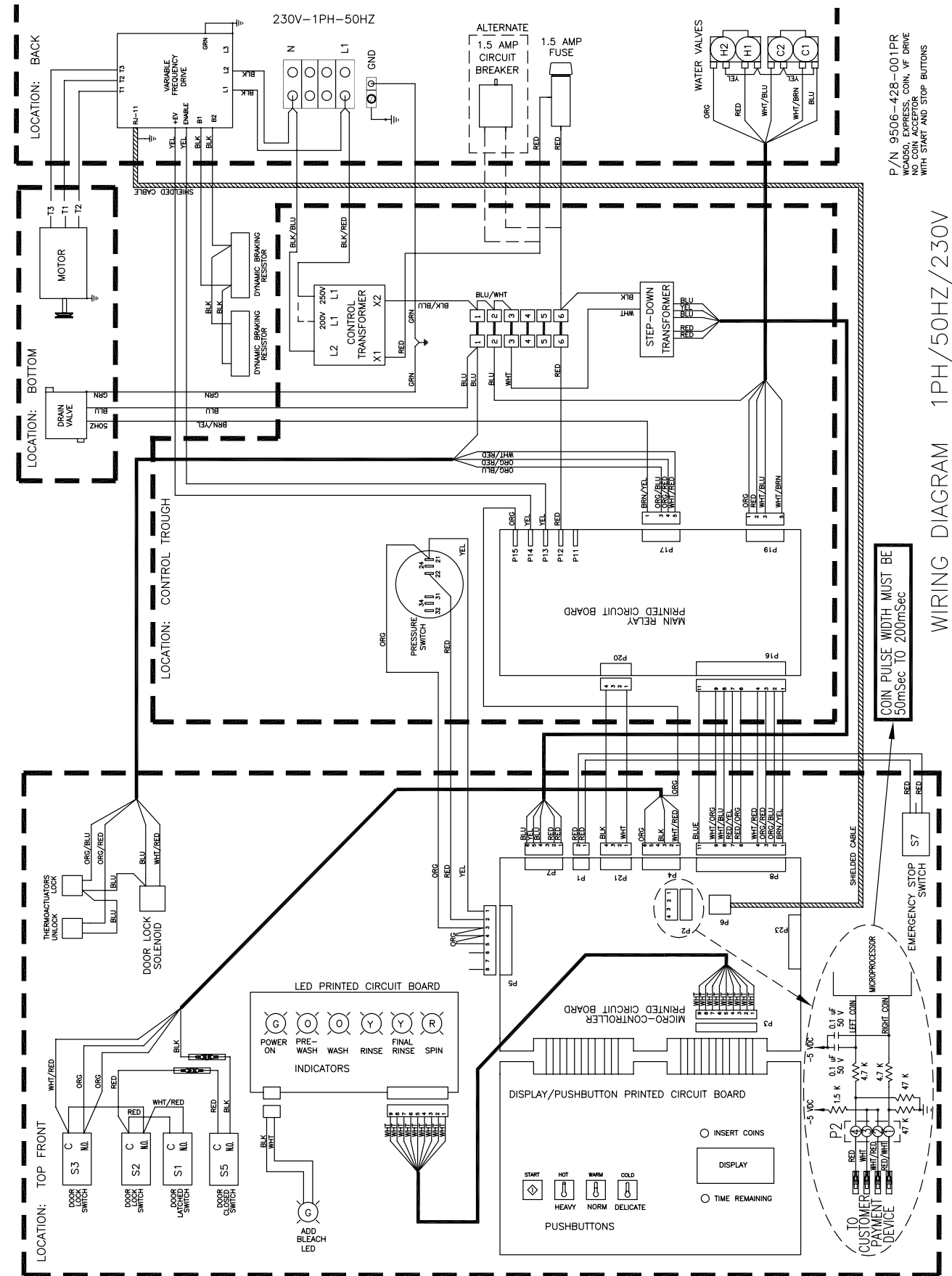

WIRING DIAGRAM 1PH/50HZ/230V

COIN PULSE WIDTH MUST BE 50mSec TO 200mSec

WCAD50KCB -59CNSZ 230/50/1 Voltage Schematic

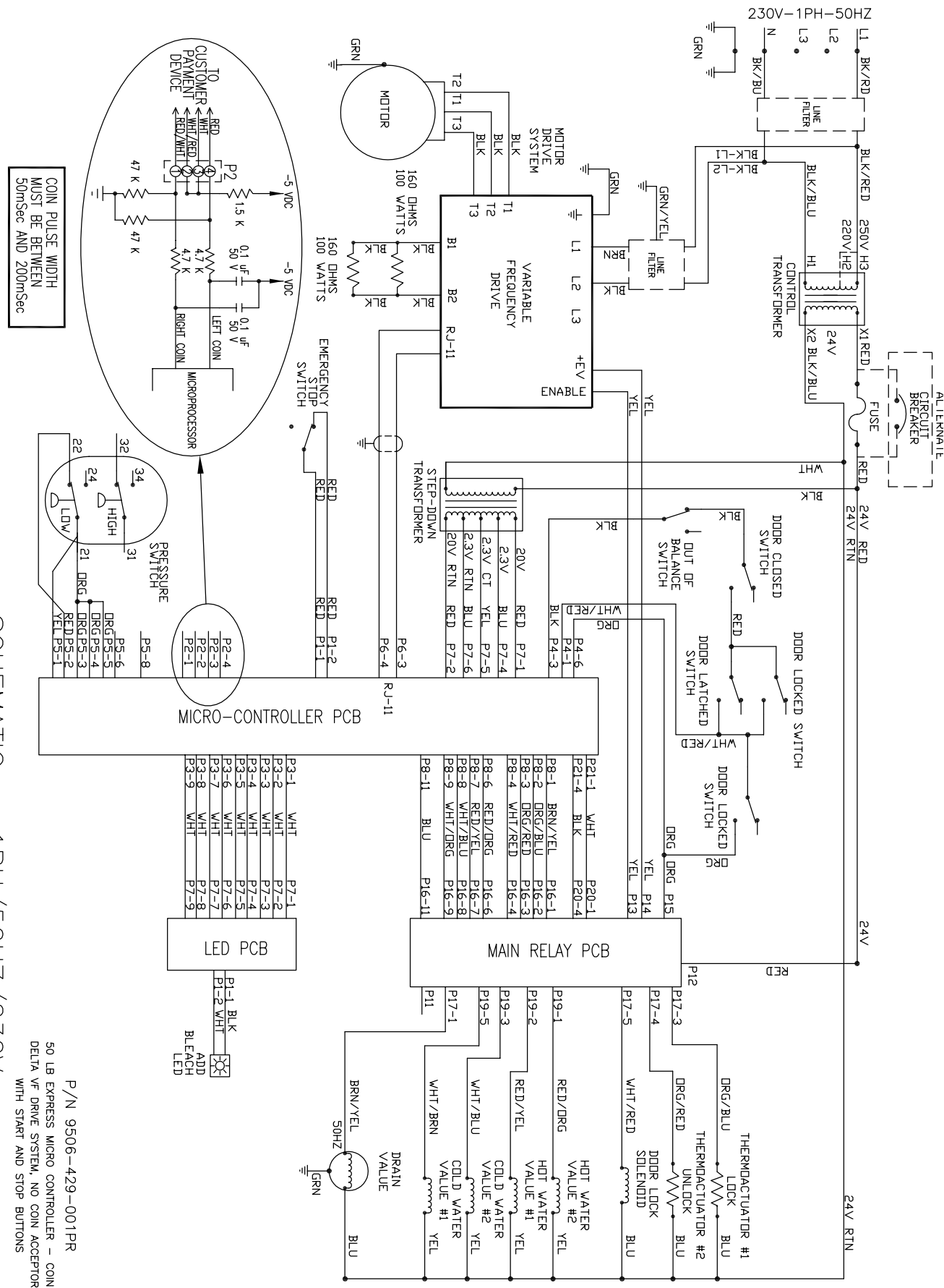

WCAD50KCB -59CNSZ 230/50/1 Voltage Diagram

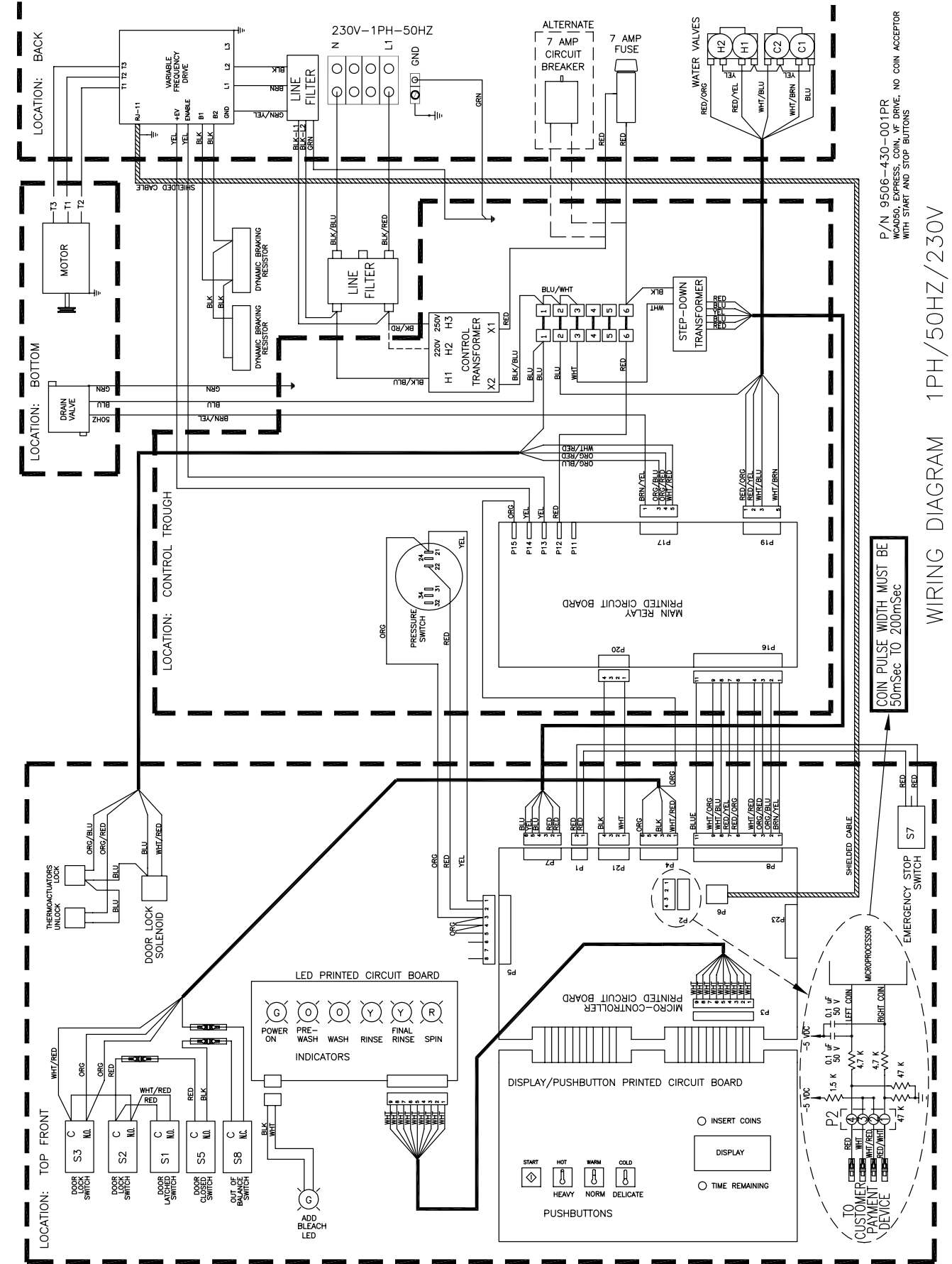

WCAD60KCB -21CN 230/50/1 Voltage Schematic

230V-1PH-50HZ

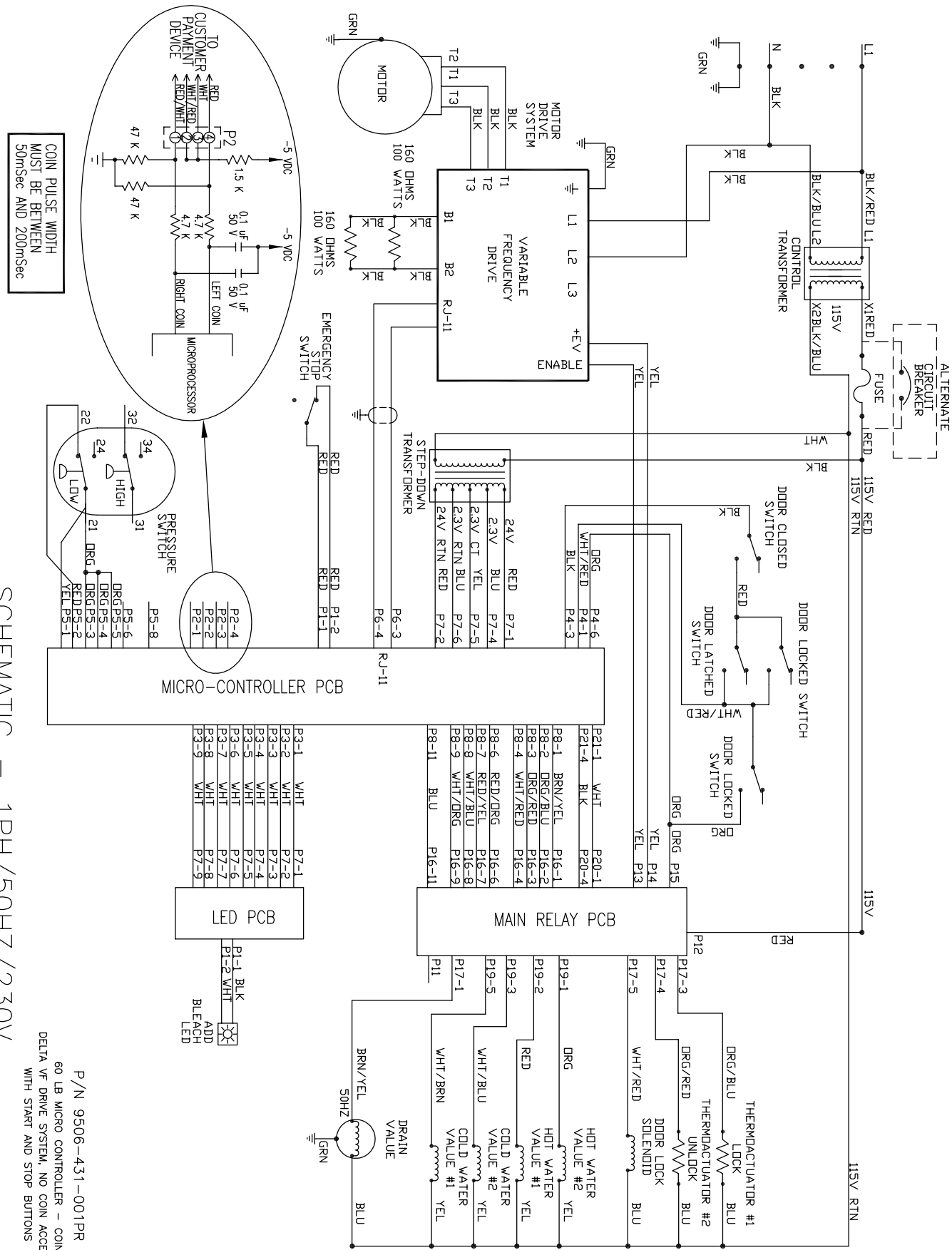

SCHEMATIC - 1PH/50HZ/230V

P/N 9506-431-001PR
60 LB MICRO CONTROLLER - COIN
DELTA V.F. DRIVE SYSTEM, NO COIN ACCEPTOR
WITH START AND STOP BUTTONS

WCAD60KCB -21CN 230/50/1 Voltage Diagram

230V-1PH-50HZ

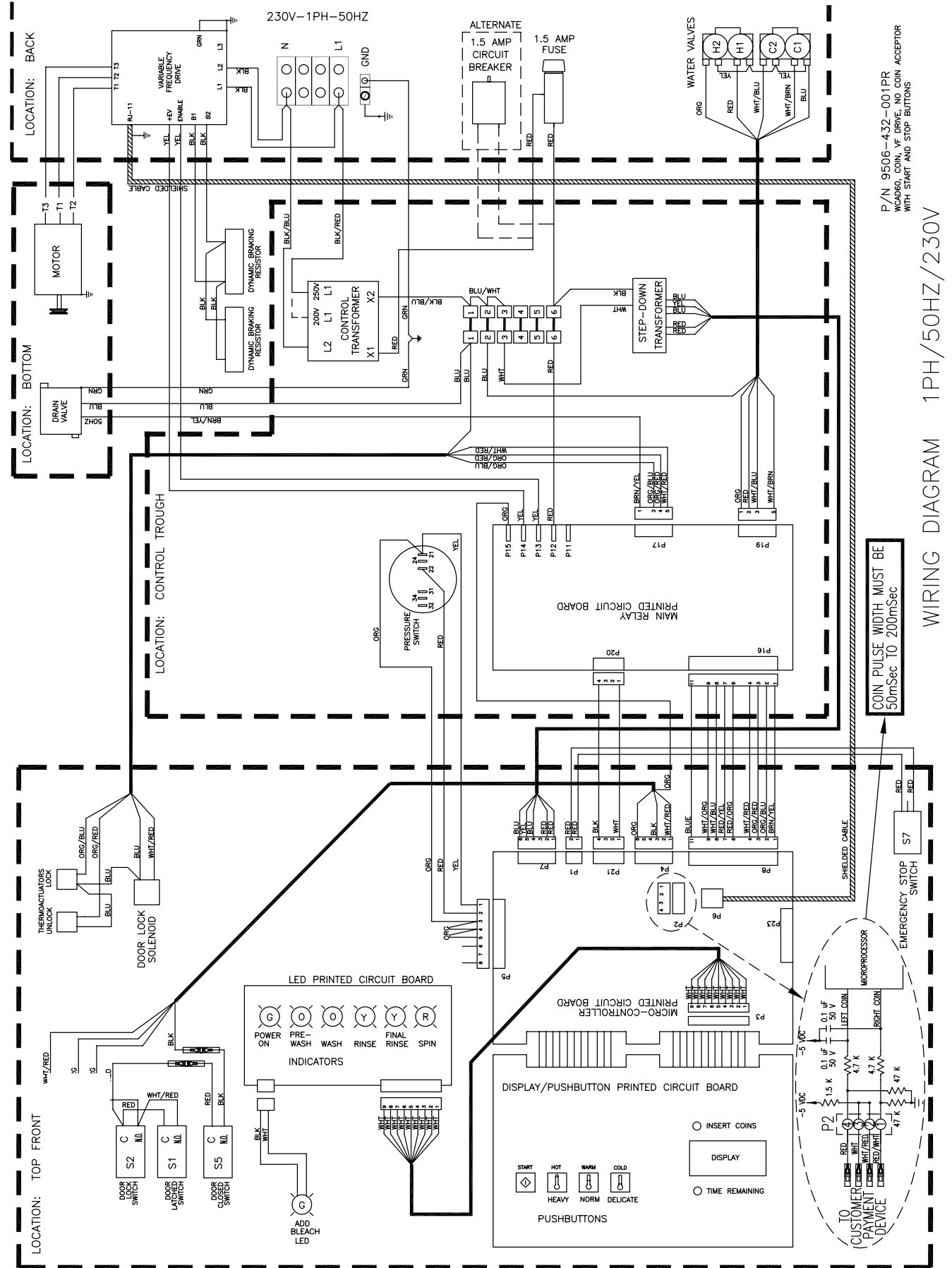

P/N 9506-432-001PR
WCAD60, COIN, V.F. DRIVE, NO COIN ACCEPTOR
WITH START AND STOP BUTTONS

WIRING DIAGRAM 1PH/50HZ/230V

COIN PULSE WIDTH MUST BE 50mSec TO 200mSec

WCAD60KCB -59CN 230/50/1 Voltage Schematic

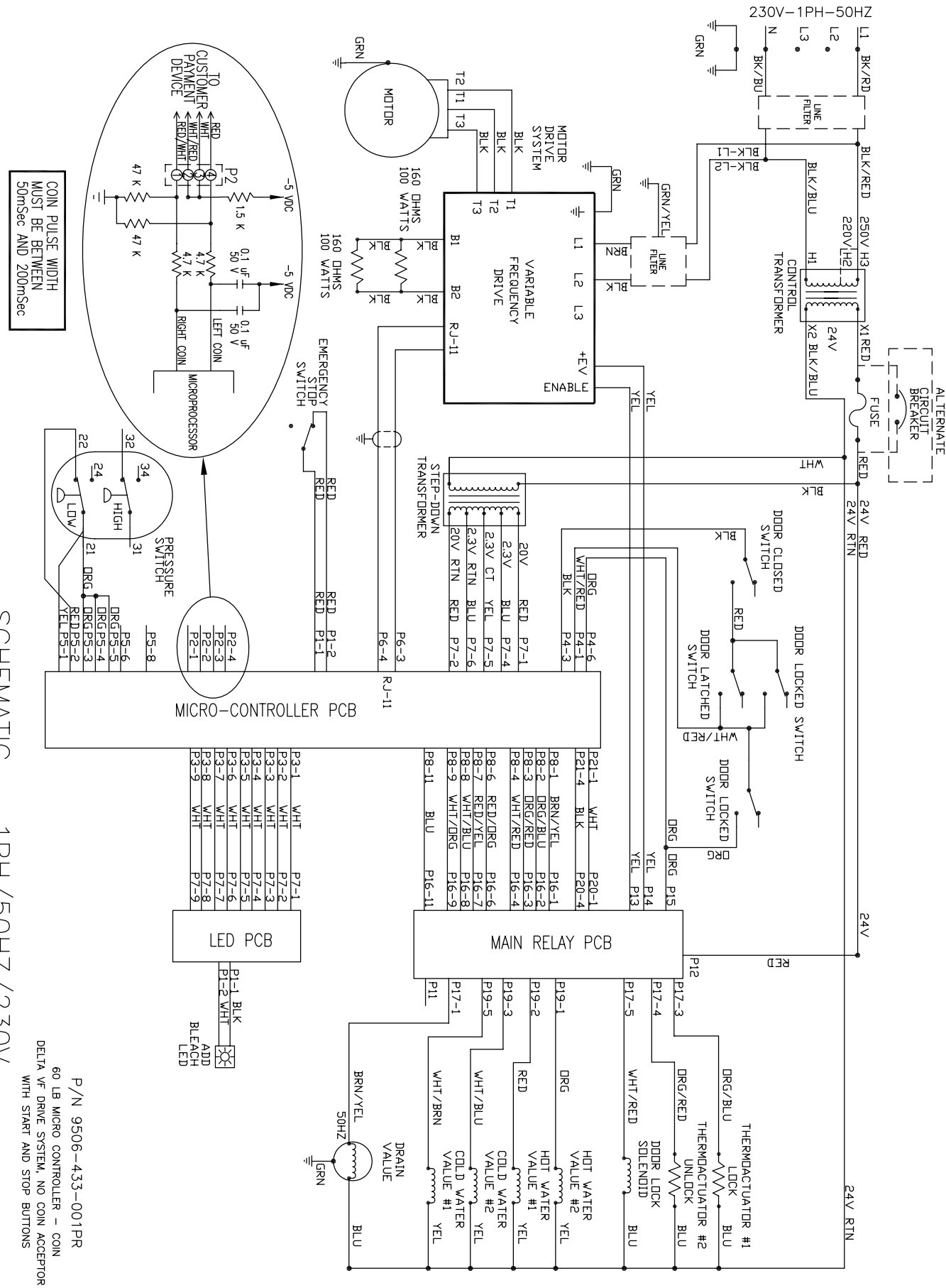

WCAD60KCB -59CN 230/50/1 Voltage Diagram

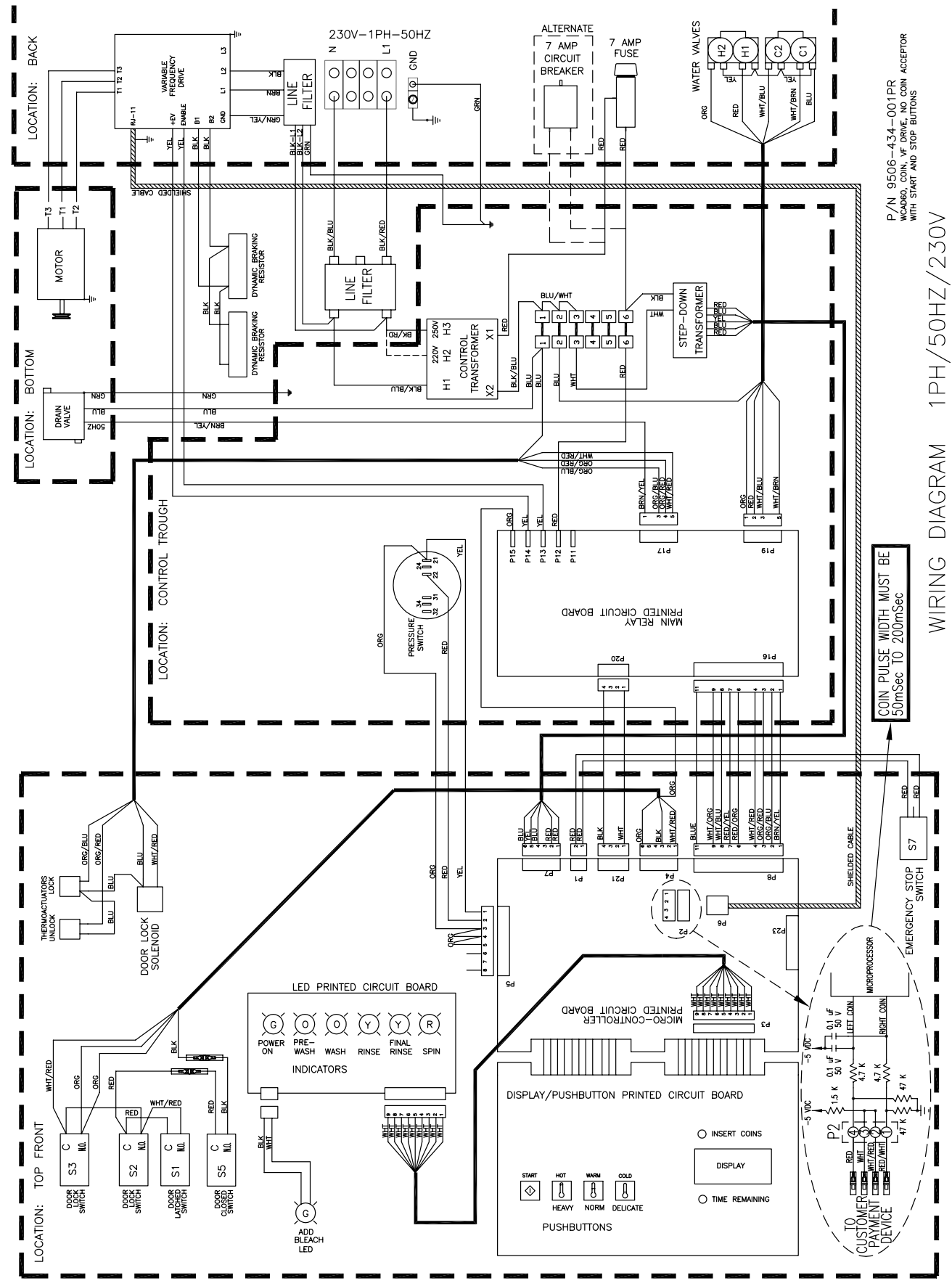

WCAD60KCB -21CNSX 230/50/1 Voltage Schematic

230V-1PH-50HZ

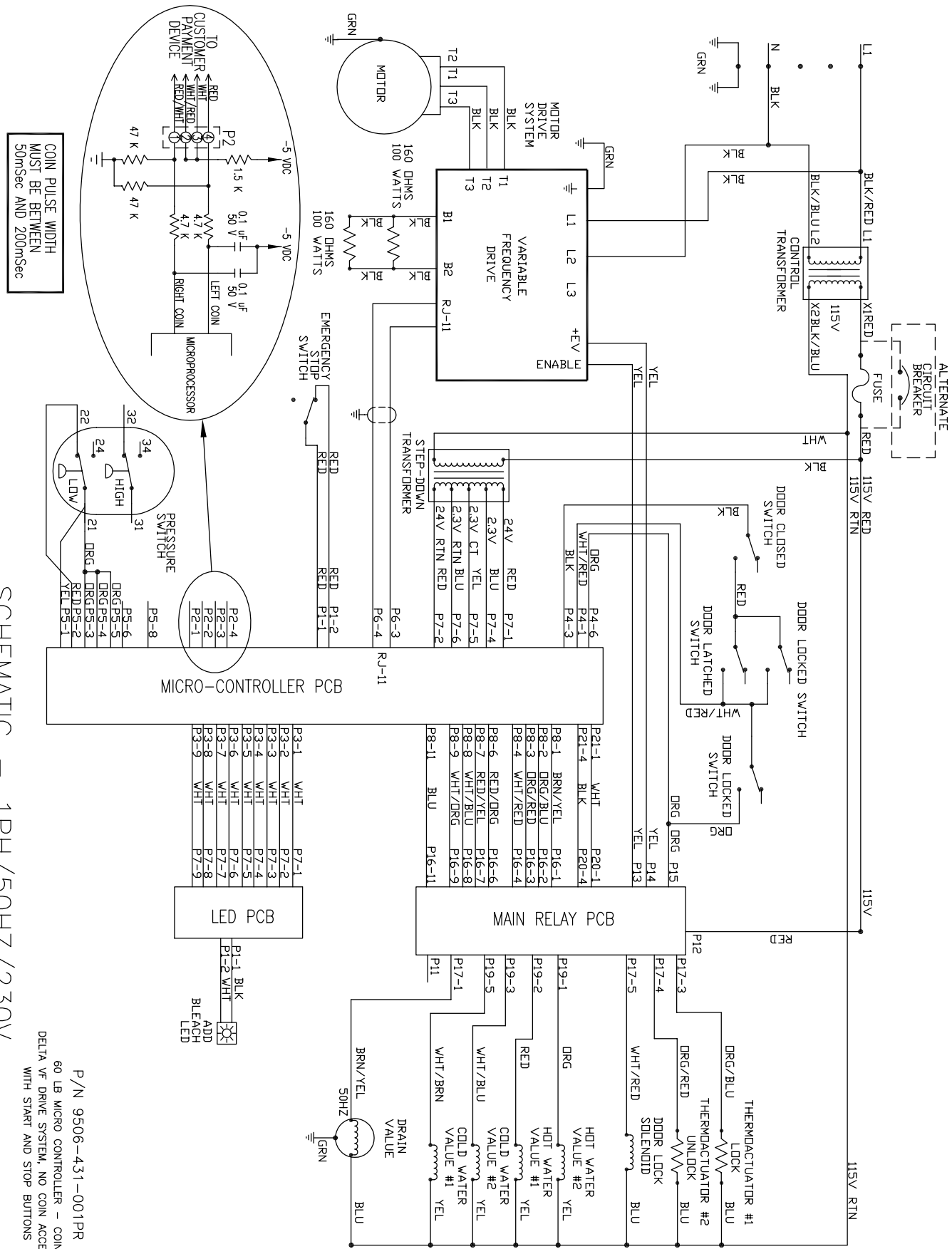

WCAD60KCB -21CNSX 230/50/1 Voltage Diagram

230V-1PH-50HZ

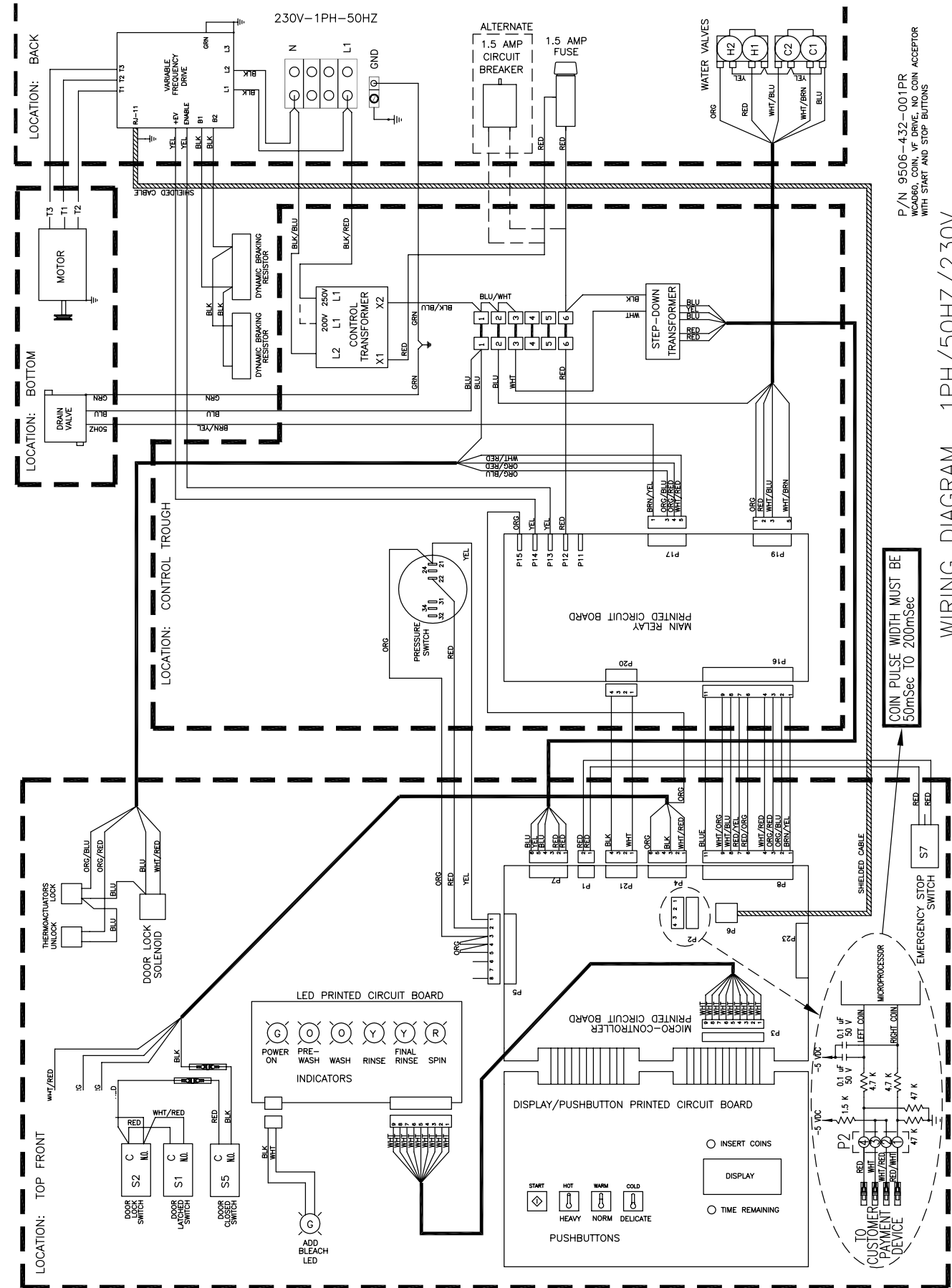

WCAD60KCB -59CNSX 230/50/1 Voltage Schematic

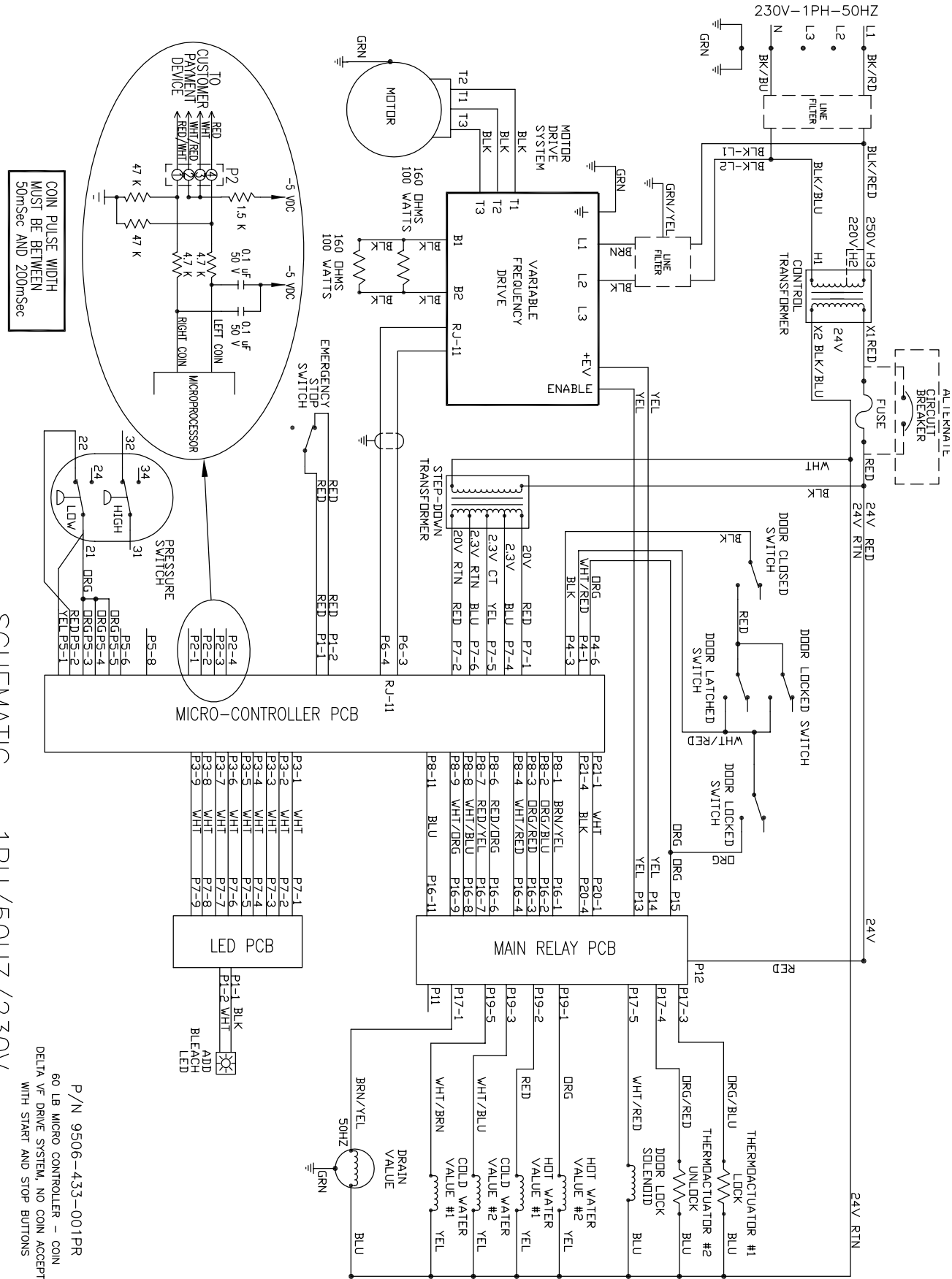

P/N 9506-433-001PR
60 LB MICRO CONTROLLER - CON
DELTA VFD DRIVE SYSTEM, NO COIN ACCEPTOR
WITH START AND STOP BUTTONS

WCAD60KCB -59CNSX 230/50/1 Voltage Diagram

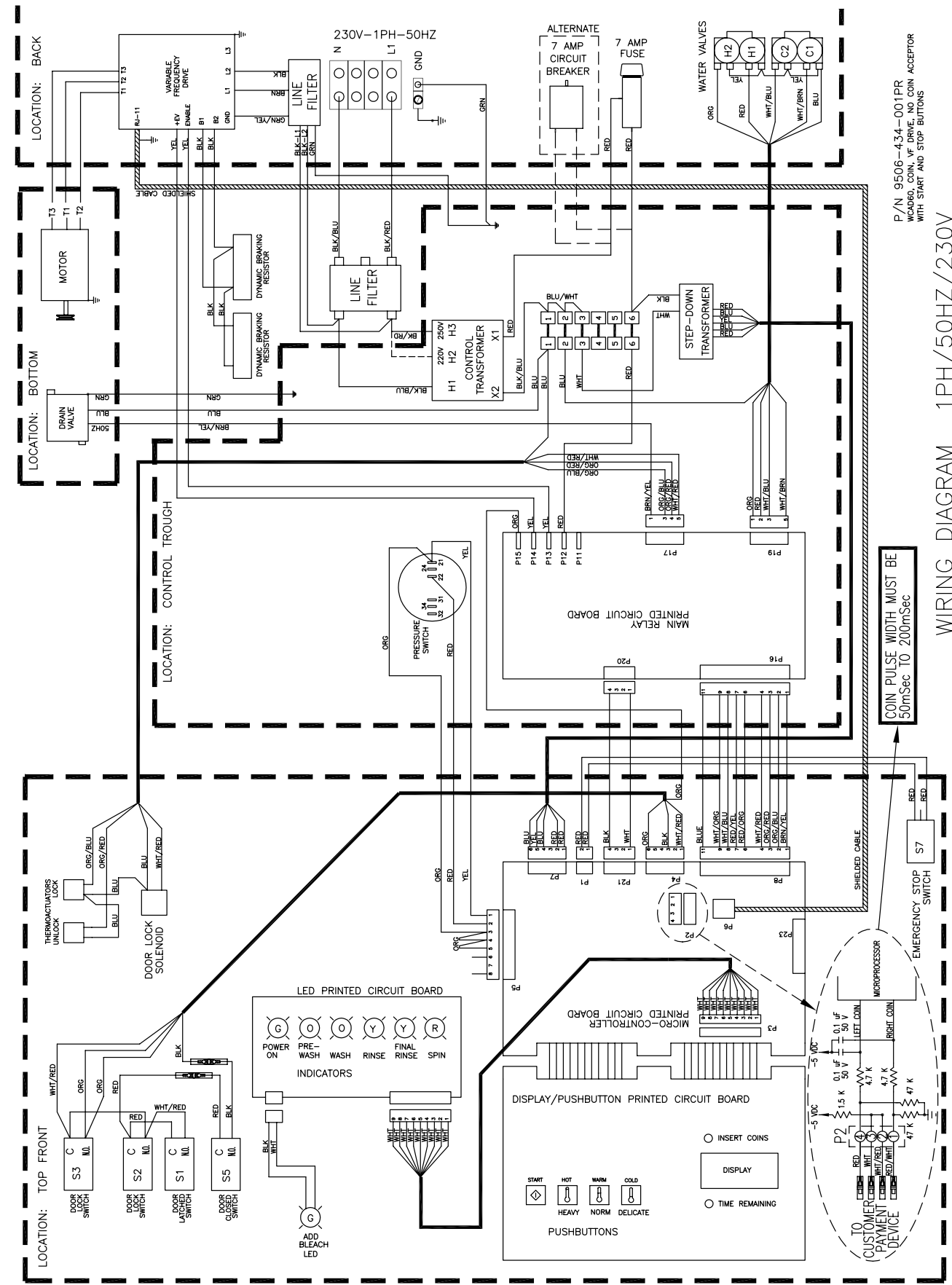

WCAD80KCB -21CN 230/50/1 Voltage Schematic

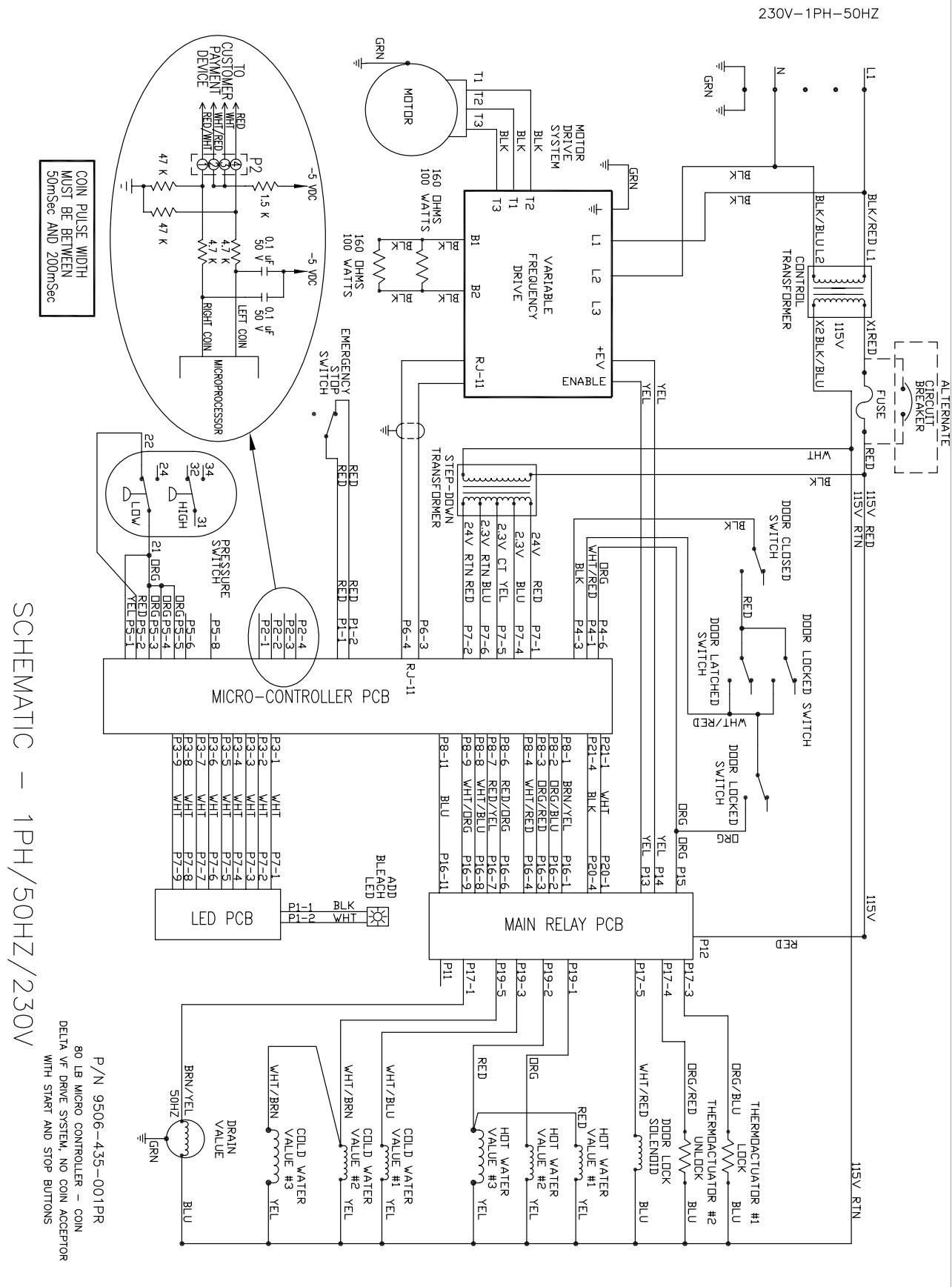

SCHEMATIC - 1PH/50HZ/230V

WCAD80KCB -21CN 230/50/1 Voltage Diagram

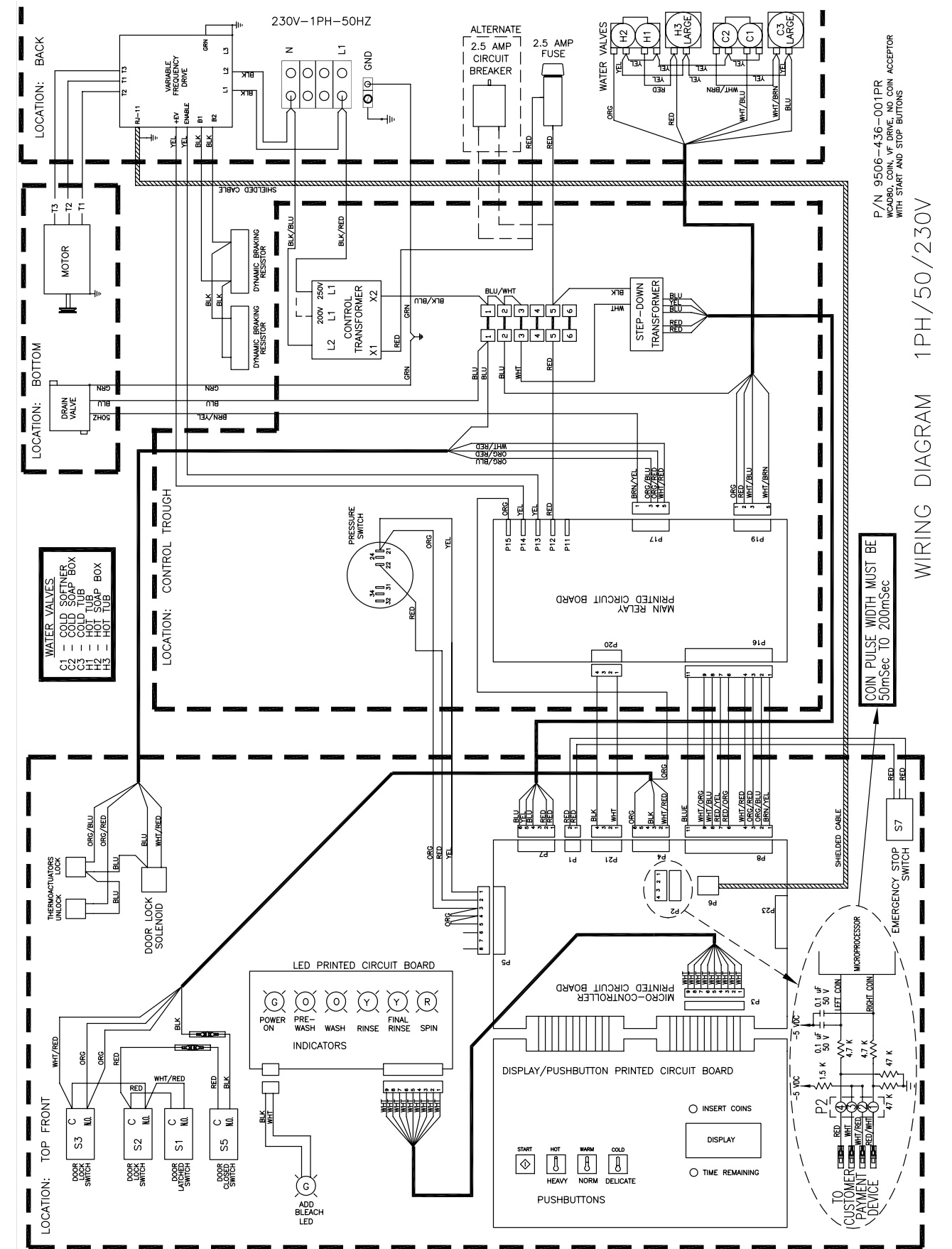

WIRING DIAGRAM 1PH/50/230V

WCAD80KCB -59CN 230/50/1 Voltage Schematic

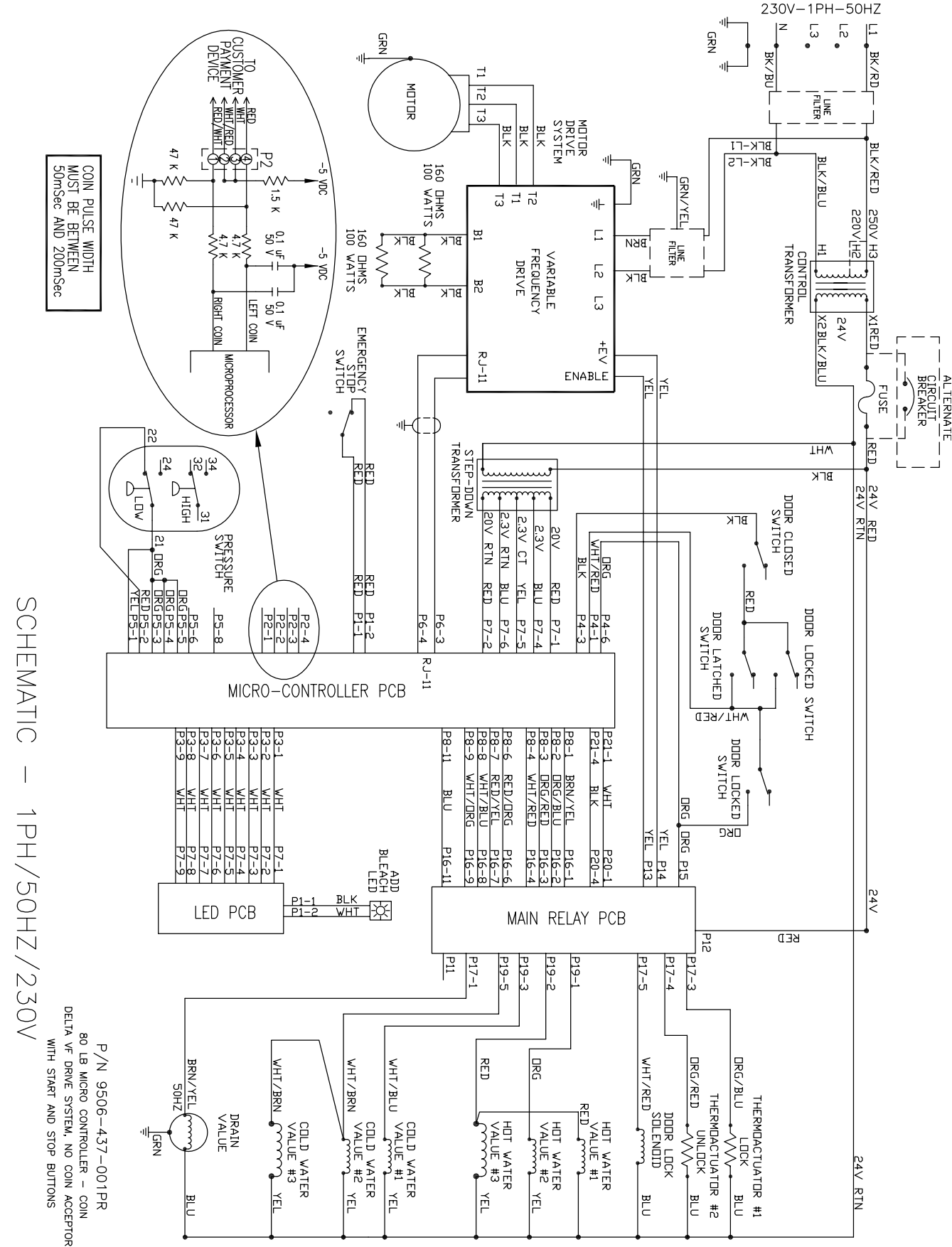

SCHEMATIC - 1PH/50HZ/230V

P/N 9506-437-001PR
80 LB MICRO CONTROLLER - COIN
DELTA VF DRIVE SYSTEM, NO COIN ACCEPTOR
WITH START AND STOP BUTTONS

WCAD80KCB -59CN 230/50/1 Voltage Diagram

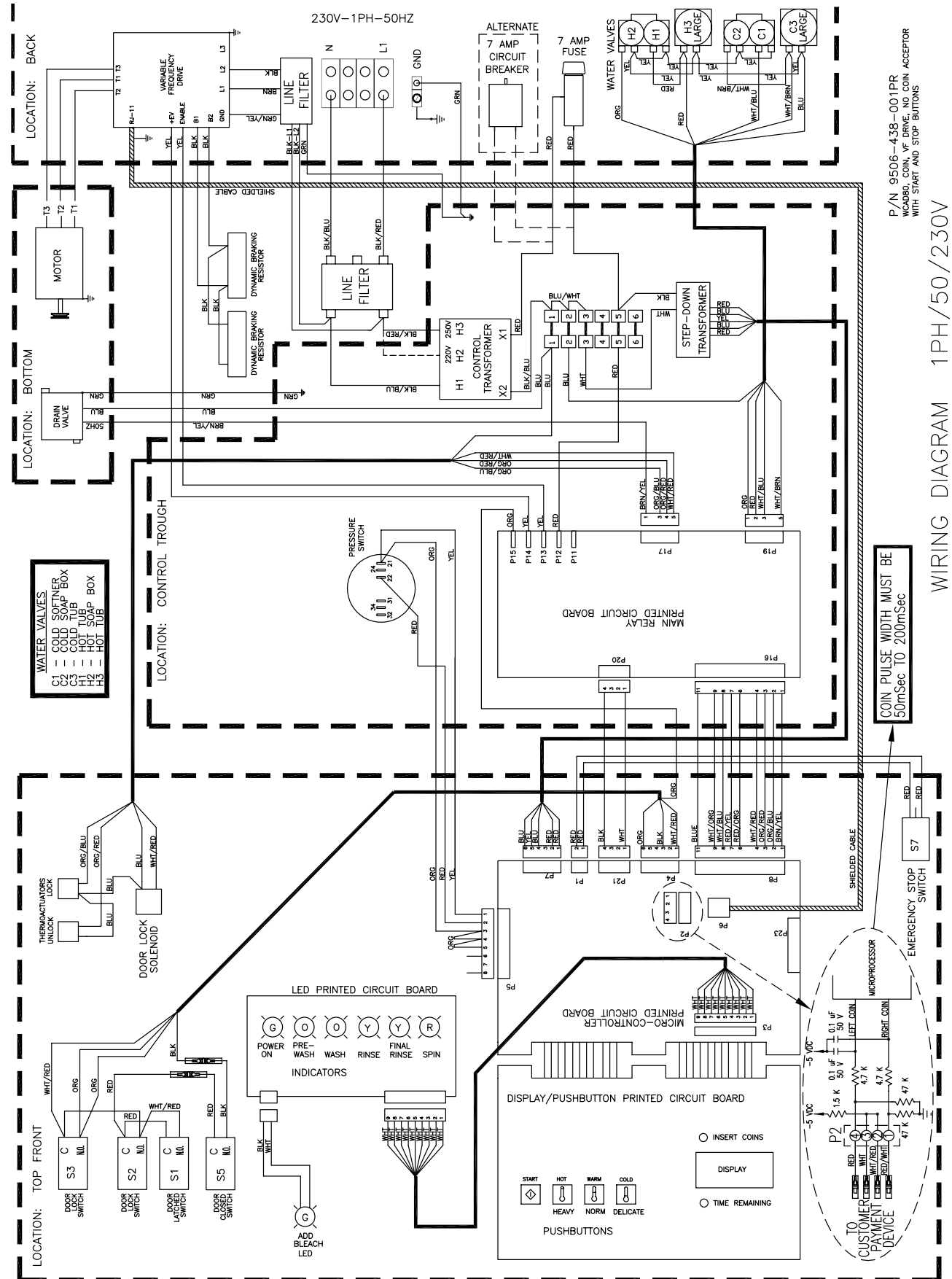

WIRING DIAGRAM 1PH/50/230V

P/N 9506-438-001PR
WCAD80, COIN, VF DRIVE, NO COIN ACCEPTOR
WITH START AND STOP BUTTONS

COIN PULSE WIDTH MUST BE
50mSec TO 200mSec