

REV	DESCRIPTION	APP
PR	RELEASE FOR PRODUCTION: 9945-159-001	SC
ECN 004994	10/06/20	

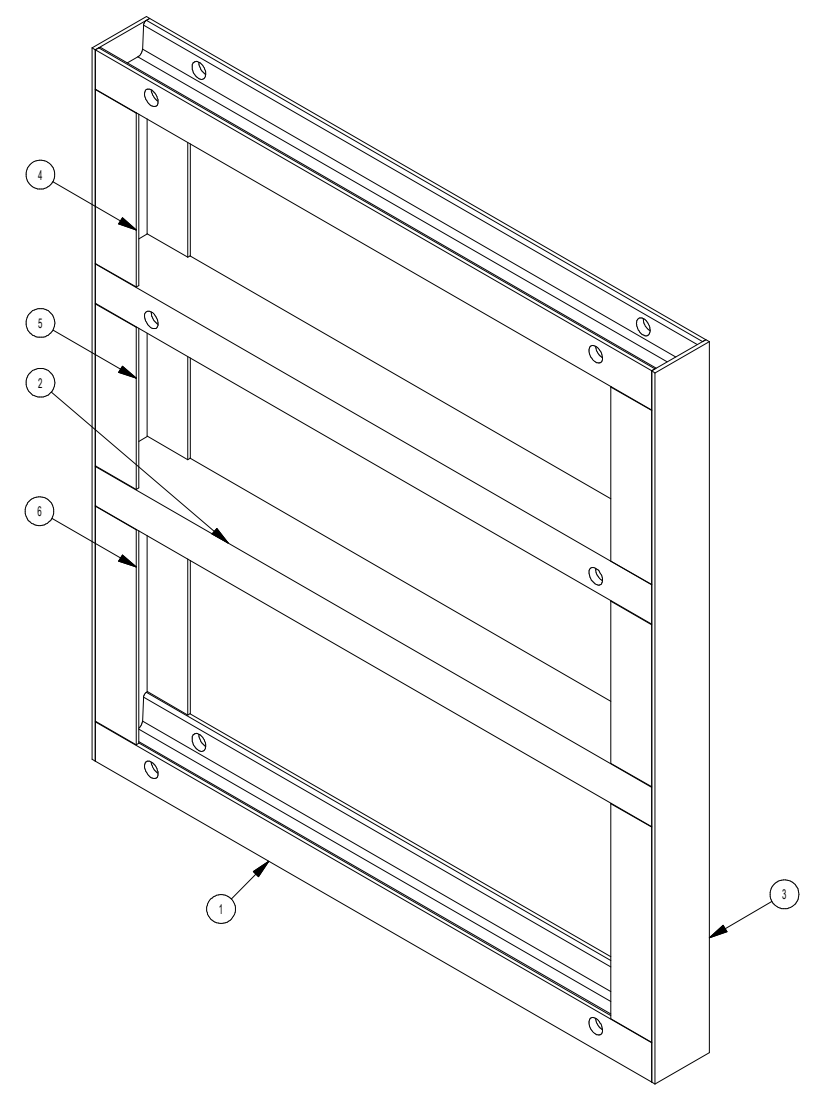
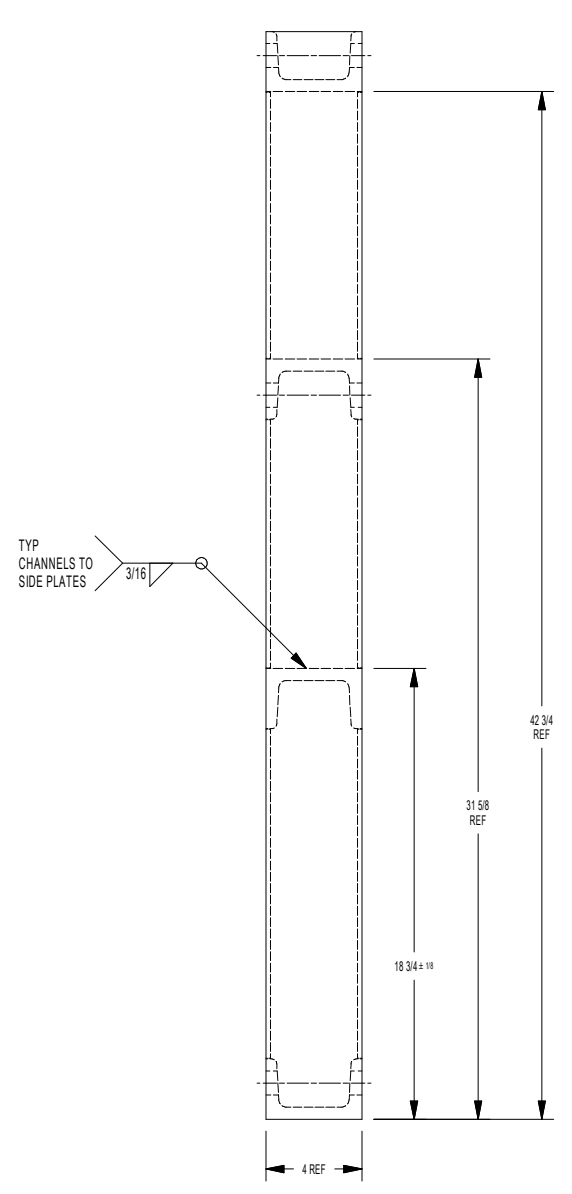
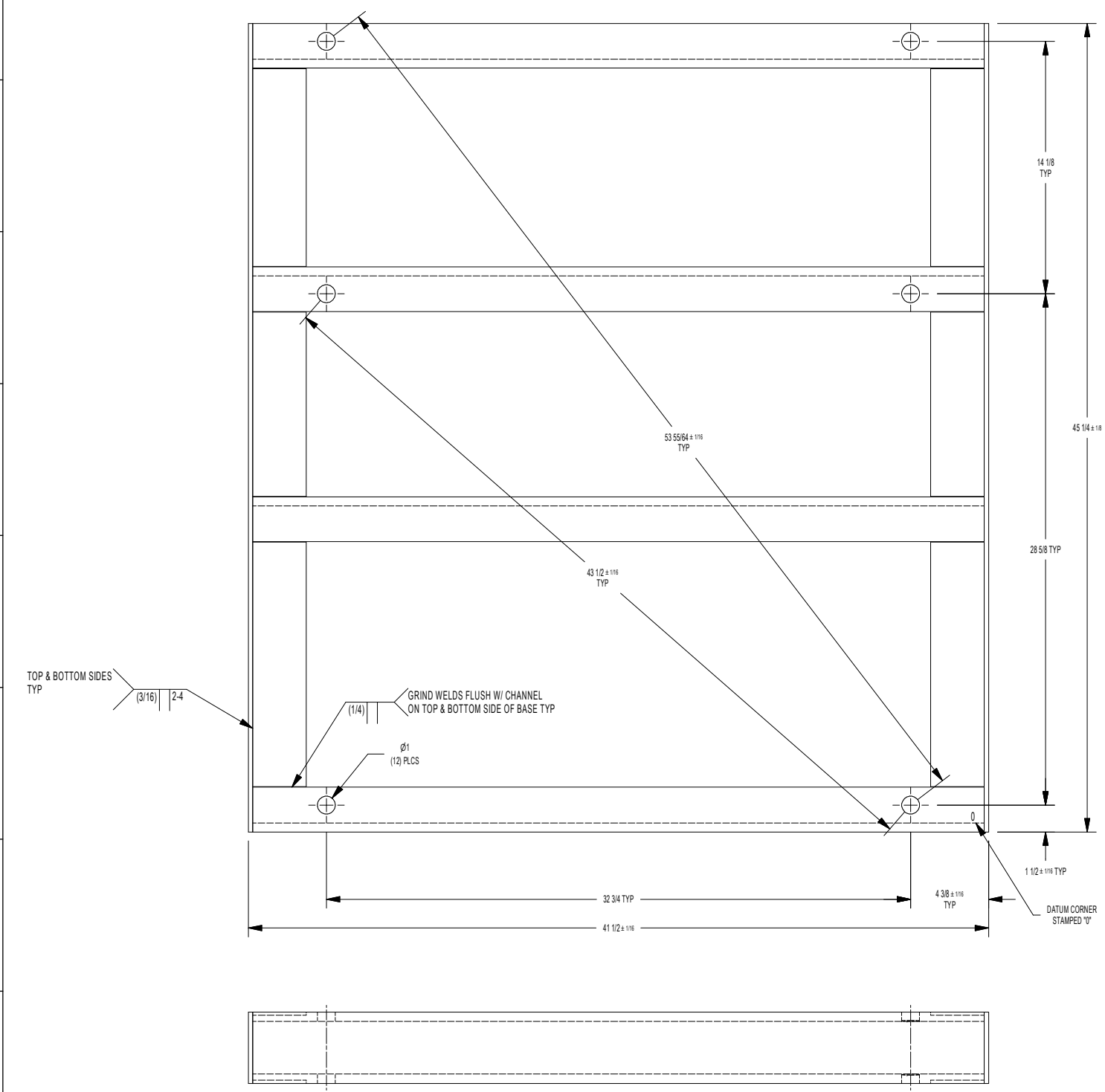

QTY	PART NUMBER	ITEM	DESCRIPTION
4	PLATE4	6	3/16 X 3 X 13 11/16 HR STEEL
4	PLATE3	5	3/16 X 3 X 10 5/16 HR STEEL
4	PLATE2	4	3/16 X 3 X 11 1/16 HR STEEL
2	PLATE1	3	1/4 X 4 X 45 1/4 HR STEEL
1	CHANNEL 2	2	MC4 X 13.8#FT STEEL CHANNEL X 41" LG - NO HOLES
3	CHANNEL 1	1	MC4 X 13.8#FT STEEL CHANNEL X 41" LG - W/ HOLES

NOTES:  
 1. PART TO BE FLAT WITHIN 1/8"  
 2. FILLER PLATES TO BE FLUSH TO 1/16" RECESSED FROM SURFACE OF CHANNELS.  
 3. APPLY (1) COAT FLAT BLACK PAINT.

STANDARD RAW STOCK COMMERCIAL TOLERANCES APPLY UNLESS EXCEPTED.

FRACIONS ± 1/64  
 DECIMALS ± .005  
 ANGULAR ± 7'  
 REFERENCE (XXX)

SCALE 1/4" = 1"

DATE: 04/2020

DWG NO: 9945-159

REV: PR

1 OF 1

9945-159-001 BASE ASSY - 1 PLACE, 4" (T-1800)

DEXTER LAUNDRY INC.  
 FAIRFIELD, IOWA