



DEXTER[®]
LAUNDRY

THIS PAGE IS INTENTIONALLY LEFT BLANK

Kits, Assemblies, & Common Parts

Description	Part Number
SWD Makeup Air Kit	9732-332-001
Cleanout Duct Assembly 8"	9973-034-001
Temperature Probe	9501-006-001
Controls Blue	9857-199-002
Controls Black	9857-199-004
Coin Drop	9021-094-001
Optical Switch	9801-099-001
Coin Drop Screws	9545-053-002
Ignition Control Box	9857-182-001
Electrode Assembly	9875-002-003
Hi-Limit Thermostat	9576-203-002
Overtemp Thermostat	9576-207-006
Fuseholder	9200-001-002
Fuse	8636-018-001
Relay	5192-299-002
Transformer	8711-007-002
Lint Screen without Front	9805-037-001
Airflow Switch	9539-461-009
Door Switch	9539-487-001
Motor Belt	9040-076-012
Tumbler Belt	9040-073-013
Tension Arm Complete Assembly	9861-022-001
Spider/Trunnion	9568-018-001
Door Handle	9244-092-001

Dryer Cabinet Group

	Description	T-20 SWD	QTY
1	Panel Assy., Front- Upper (SS)	9989-591-001	1
*	Insulation Front Panel, half moon (top)	9277-064-001	1
*	Insulation Front Panel, half moon (bottom)	9277-064-002	1
2	Screw, FLHDCR, 10B x 1 3/4	9545-008-014	4
3	Washer, Finish, #10	8641-585-001	4
*	Nut, Spring	8640-399-001	4
*	Hinge ,Backup Plate	9982-392-001	1
*	Screw, Countersink, 10-32X 1/2	9545-012-003	2
4	Strap, Hinge (SS/Black)	9544-074-002	2
*	Screw, Hinge to Panel	9545-012-028	4
*	Door Assy., Loading Complete-Chrome/BLK/SS	9960-315-002	1
5	Door Assy., Loading-Chrome(ring only)	9960-314-003	1
6	Plate Assy., Hinge (SS)	9982-393-001	1
*	Screw, Hinge to Door	9545-012-015	4
*	Nut, Hinge to Door	8640-413-002	4
*	Cover, Hinge Plate	9074-377-002	1
*	Screw, Phillips-10B x 3/8	9545-008-010	2
7	Glass, Door	9212-002-005	1
8	Gasket, Glass Black	9206-413-003	1
*	Support, Door Glass	9548-117-000	1
*	Tool Install Dryer Door Gasket	8545-064-001	1
9	Gasket, Outer Rim Black	9206-420-006	1
10	Handle, Loading Door	9244-092-001	1
*	Screw, Handle 1/4-20 x 3/8	9545-018-017	2
11	Stud, Door Catch, 7/8	9531-033-002	1
12	Nut, Hex	8640-413-001	1
13	Nut, Acorn	8640-413-003	1
14	Catch, Loading Door	9086-015-002	1
15	Pop Rivet for mtg. catch	8638-190-009	2
16	Screw, Door to Hinge Strap (Special Black Type)	9545-052-001	1
17	Washer, Fiber	8641-436-003	1
18	Acceptor, Coin	9021-094-001	1
*	Retainer, Coin Acceptor	9486-145-001	2
19	Screw, 4Bx5/8ss, T10	9545-053-002	4
*	Switch, Optical	9801-099-001	1
*	Cabinet Touch Up Paint (White)	9472-001-013	1

Cabinet Group

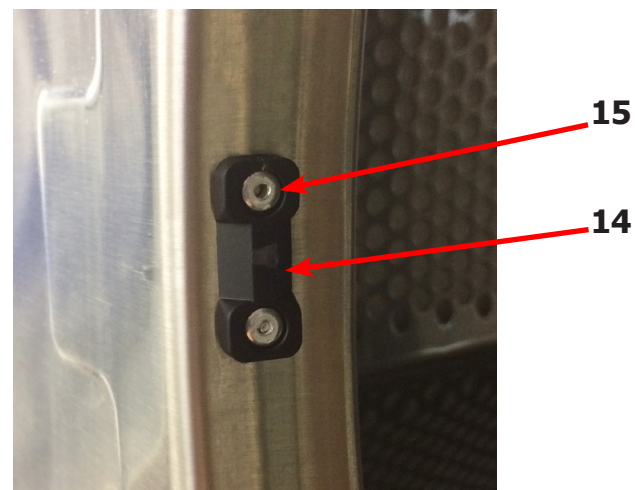
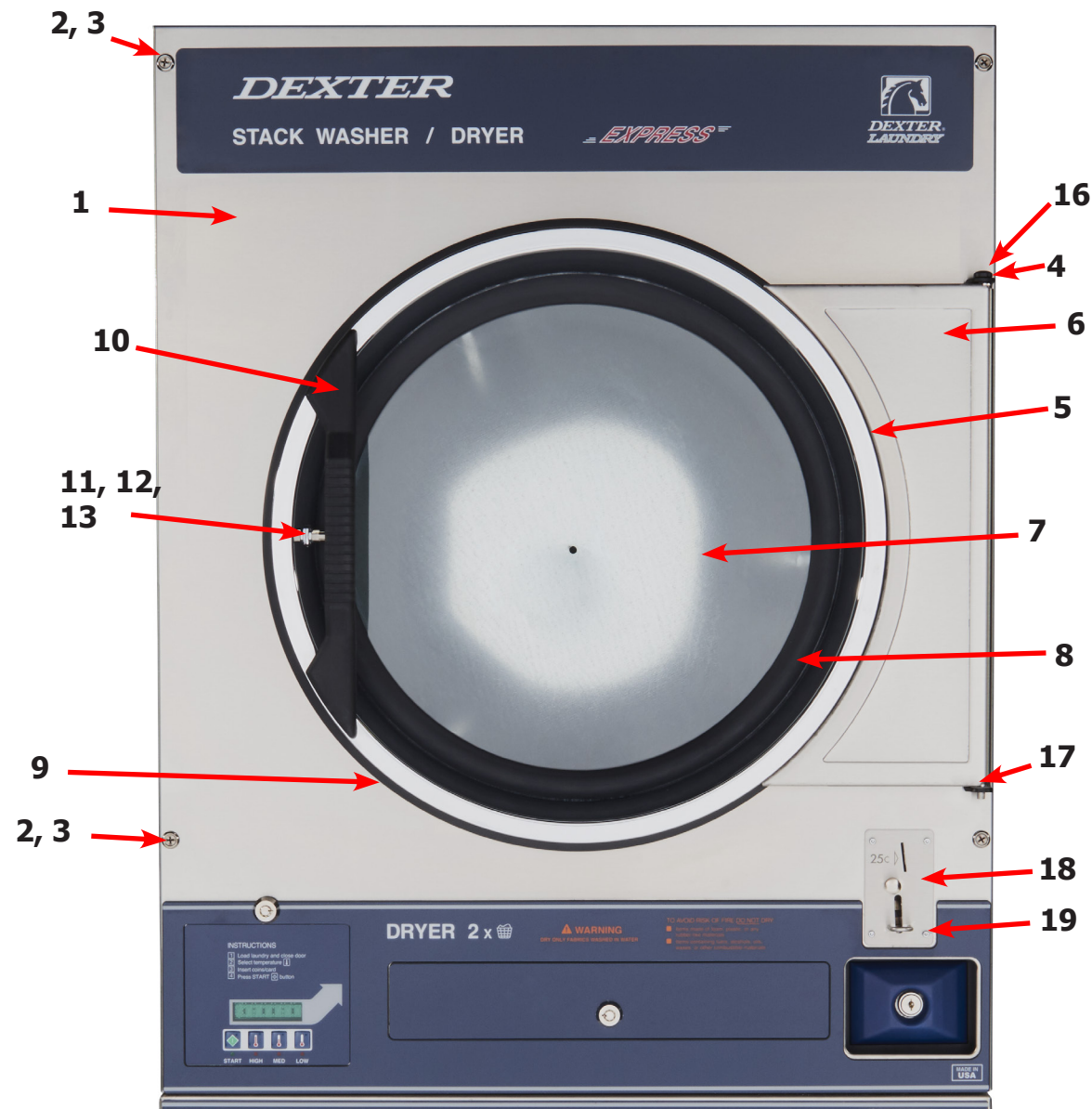

Dryer Cabinet Group

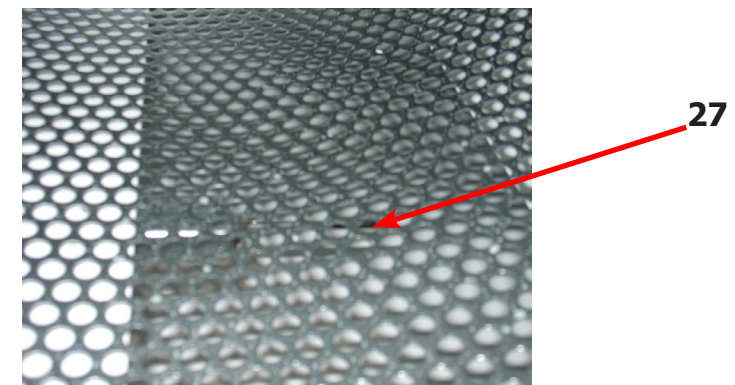
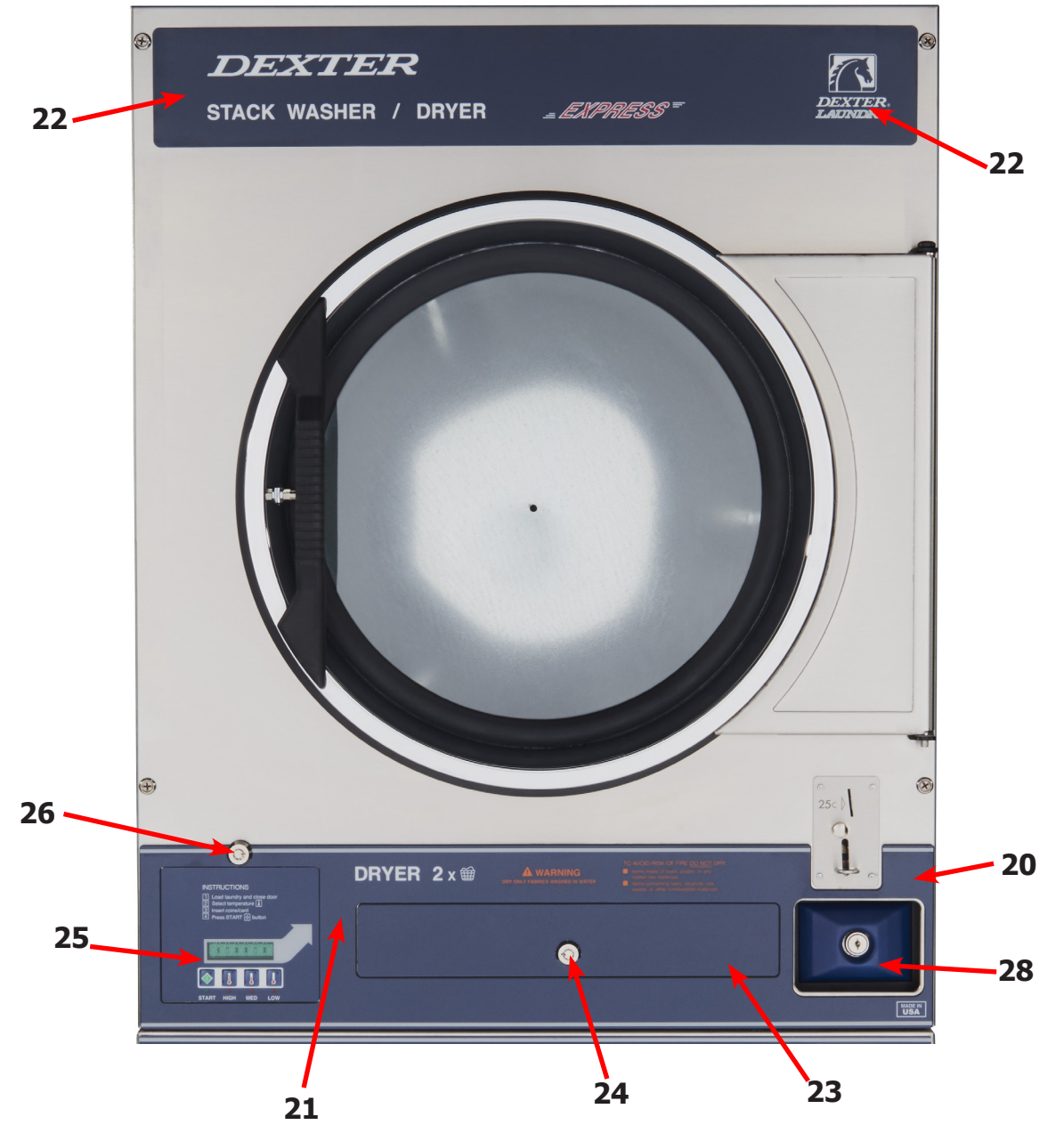

Cabinet Group Continued

Key	Description	T-30 SWD	QTY
20	Escutcheon, SWD, Dryer Coin	9994-038-001	1
21	Trim, Overlay Blue	9435-051-002	1
21	Trim, Overlay Black	9435-051-001	1
*	Screw, #4-40 x 3/16	9545-020-009	13
22	Nameplate Stack Dryer Express Blue	9412-240-002	1
22	Nameplate Stack Dryer Express Black	9412-240-001	1
*	Lint Drawer Assembly Blue	9866-008-001	1
*	Lint Drawer Assembly Black	9866-008-003	1
*	Drawer, Front	9974-016-002	1
*	Washer, Flat, #10	8641-581-006	2
*	Washer, Curved-Spring	8641-569-004	2
*	Nut, 10-32	8640-413-007	2
23	Overlay Trim, Lint Drwr-Blue	9435-053-002	1
23	Overlay Trim, Lint Drwr-Black	9435-053-001	1
*	Felt Seal (back of lint screen assembly)	9532-142-001	1
*	Lint Screen Assembly ONLY (no front)	9805-037-001	1
*	Replaceable Lint Screen Only	9555-057-011	1
24	Lock and Key, Lint Drawer	8650-012-004	1
*	Key 6101 only	6292-006-010	1
*	Cam, Lock	9095-043-001	1
*	Lint Screen Strap Hold Down Screws 10Bx 1/4	9545-008-001	12
25	Controls Assy, 24VAC, Blue	9857-199-002	1
25	Controls Assy, 24VAC, Black	9857-199-004	1
*	Harness, Electronic Control	9627-913-004	1
26	Lock and Key, Control	8650-012-003	1
*	Cam, Lock	9095-041-001	1
*	Washer-flat,shim	8641-581-010	2
*	Washer-flat	8641-581-041	1
*	Key only 6324	6292-006-007	1
27	Sensor Temp Control	9501-006-001	1
*	Harness, Main	9627-913-004	1
*	Wire Nut Connector Grey	8640-276-002	2
*	Cover, Cabinet (Top)	9074-374-001	1
*	Insulation Cabinet Cover	9277-041-028	1
*	Insulation-side Panel	9277-041-027	2
*	Stack Dryer Trunnion Puller	9732-243-002	1
*	Vault, Coin Box	9942-028-005	1
*	Screws, Mounting-Coin Vault	9545-008-024	2
28	Coin Box Assy, Small Blue	9807-099-001	1
28	Coin Box Assy, Small Black	9807-099-003	1
*	Nut, Elastic Stop	8640-413-004	*

Dryer Back Panels and Guards

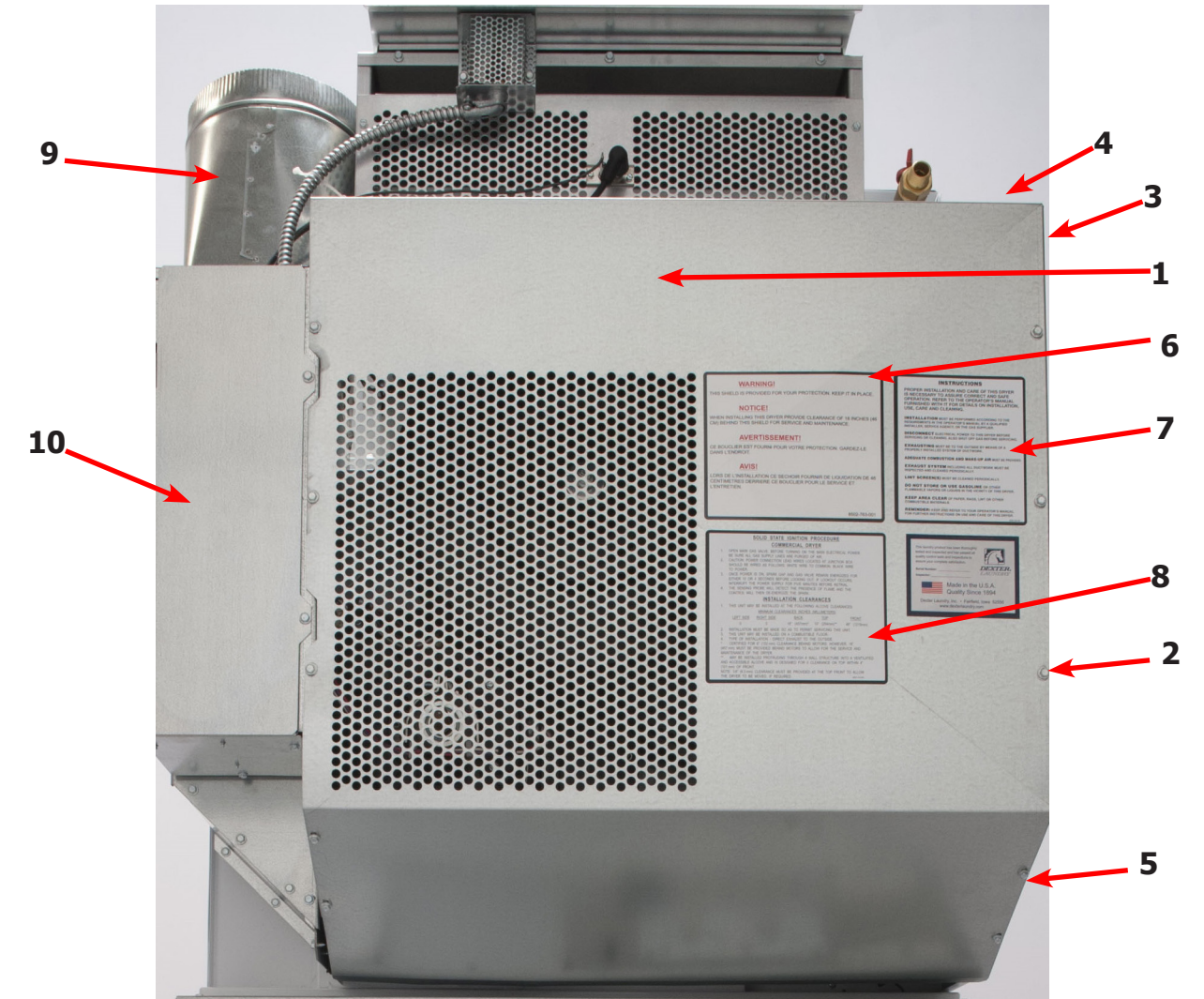

Key	Description	Part Number	Qty
1	Guard, Drive	9208-133-001	1
2	Screw, 10AB x 3/8	9545-008-024	20
3	Panel, Side Guard (Before 8/1/2019)	9208-131-001	1
4	Guard-Small, upper (Before 8/1/2019)	9208-134-001	1
5	Guard-side,lower (Before 8/1/2019)	9208-132-001	1
5	Guard-Side (After 8/1/2019)	9208-153-001	1
6	Warning, Label	8502-763-001	1
7	Label, Instructions	8502-645-001	1
8	Lighting and Clearance, Label	8527-112-001	1
9	Duct, Transition	9109-127-001	1
10	Door, Cover-Control Box	9108-141-001	1
*	Cabinet, Cover	9074-374-001	1
*	Insulation	9277-041-028	1
*	Wiring Diagram & Schematic	9506-808-001	1
*	6" Slide Open Clean Out Duct (Optional)	9973-035-001	1

Air Flow Switch Assembly

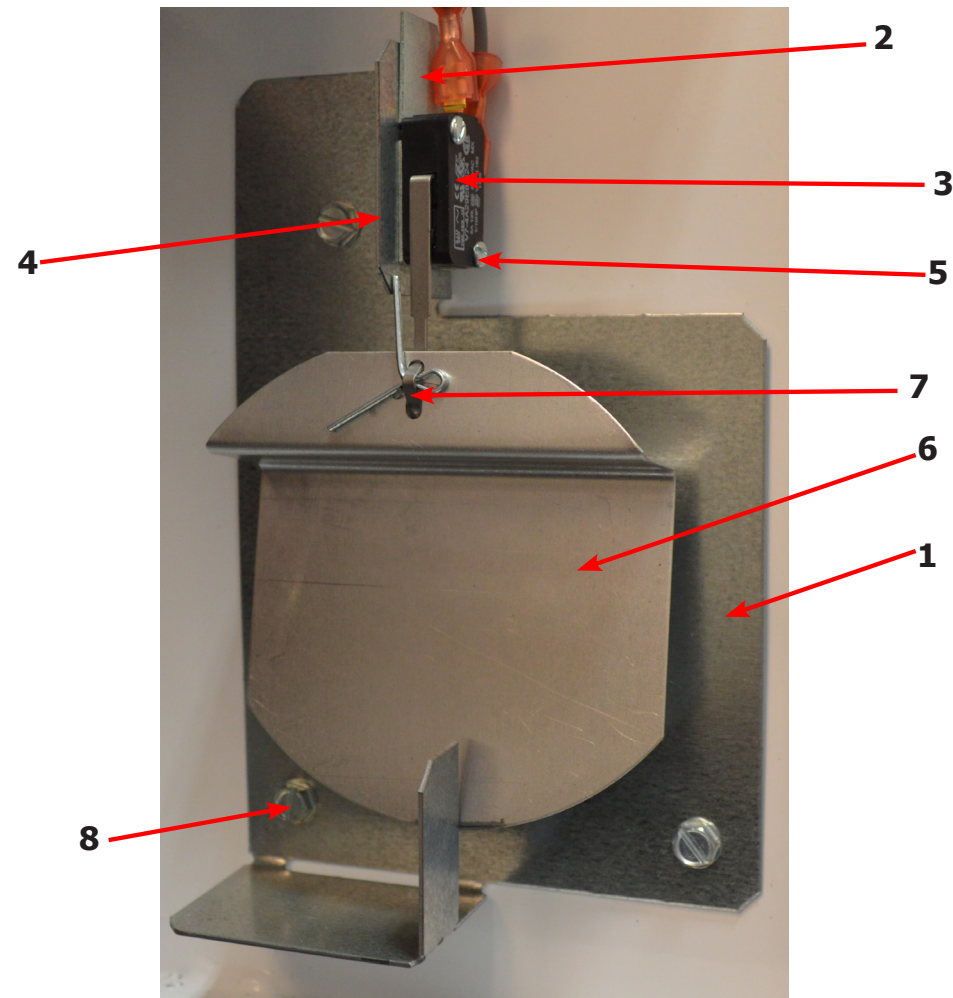

Key	Description	T-20 SWD	QTY
*	Air Flow switch Assy	9801-095-001	2
1	Bracket-Airflow switch	9029-174-001	2
2	Shield-Switch	9550-169-003	2
3	Switch-Micro	9539-461-009	2
4	Nut-Twin, 4-40	8640-401-001	2
5	Screw-.625, 4-40	9545-020-001	2
6	Actuator-Air Flow Switch	9008-007-001	2
7	Pin-Cotter, .09375x.75	9451-169-002	2
8	Screw, 10AB x 1/4	9545-008-001	3
*	Wireasy-brn,#13,34"	8220-063-032	1
*	Wireasy-org,#14,24"	8220-095-040	1
*	Wireasy-vio,54"	8220-103-001	1

Dryer Burner Housing Group

Key	Description	T-20 SWD	QTY
*	Housing Assembly, Burner (All sheet metal parts not listed)	9803-228-003	1
1	Panel, Back Burner Housing	9454-990-001	1
2	Screw, 10B X 1/4"	9545-008-001	4
3	Angle, Burner Support	9003-220-001	1
*	Screw, 10B x 3/8"	9545-008-006	2
4	Burner, Main	9048-023-001	2
*	Screw 10AB x 3/8"	9545-008-006	2
5	Electrode-ignition	9875-002-003	1
6	Screw, Electrode Mtg 8B x 1/4"	9545-045-001	2
7	Valve, Gas Shut Off (Optional)	9379-196-001	1
8	Pipe Nipple, 1/2 x 4 1/2, BLK	8655-073-008	1
9	Elbow, 1/2 x 90, BLK	8615-104-037	1
10	Pipe Nipple, 1/2 x 3 1/2, BLK	8655-073-047	1
11	Control Assy, Gas	9857-192-001	1
*	Wireasy-yel,47/8"	8220-001-466	1
12	Manifold, Assy	9381-012-001	1
*	Orifice, Burner-Natural #40	9425-069-030	2
*	Orifice, Burner-LP #54	9425-069-031	2
13	Bracket, Manifold	9029-175-001	2
14	Pipe Plug in end of Burner Manifold	8615-104-038	1
*	Screw, 10AB x 3/8"	9545-008-006	2
15	Bracket, High Limit Thermostat	9029-192-001	1
16	Thermostat, Hi-Limit	9576-203-002	1
*	Spacer, Hi-Limit	9538-142-001	2
*	Screw 8B x 3/4"	9545-045-007	2
17	Cover, Hi-Limit Stat	9074-329-001	1
*	Screw, 10AB x 3/8"	9545-008-006	2
18	Thermostat, Safety Shutoff	9576-207-006	1
19	Screw, 10AB x 3/8"	9545-008-006	2
*	Control, Ignition Fenwall (3 trybox)	9857-182-001	1
*	Kit, LP Conversion 20Lb Stack Kit	9732-102-046	1

Bearing Housing Group

Key	Description	T-20 SWD	QTY
	Bearing Housing Complete Assy (Includes bearings & Spacer)	9803-160-003	1
1	Housing, Bearing	9241-161-002	1
*	Spacer, Bearing	9538-139-002	1
2	Bearing, Ball, Front & Rear	9036-130-001	2
3	Screw-Wizlock, 3/8-24x3/4	9545-049-002	4
4	Nut, 5/16-18	8640-400-002	4
5	Screw, 3/8-24x1	9545-049-001	2
6	Nut, 3/8-24	8640-415-002	2

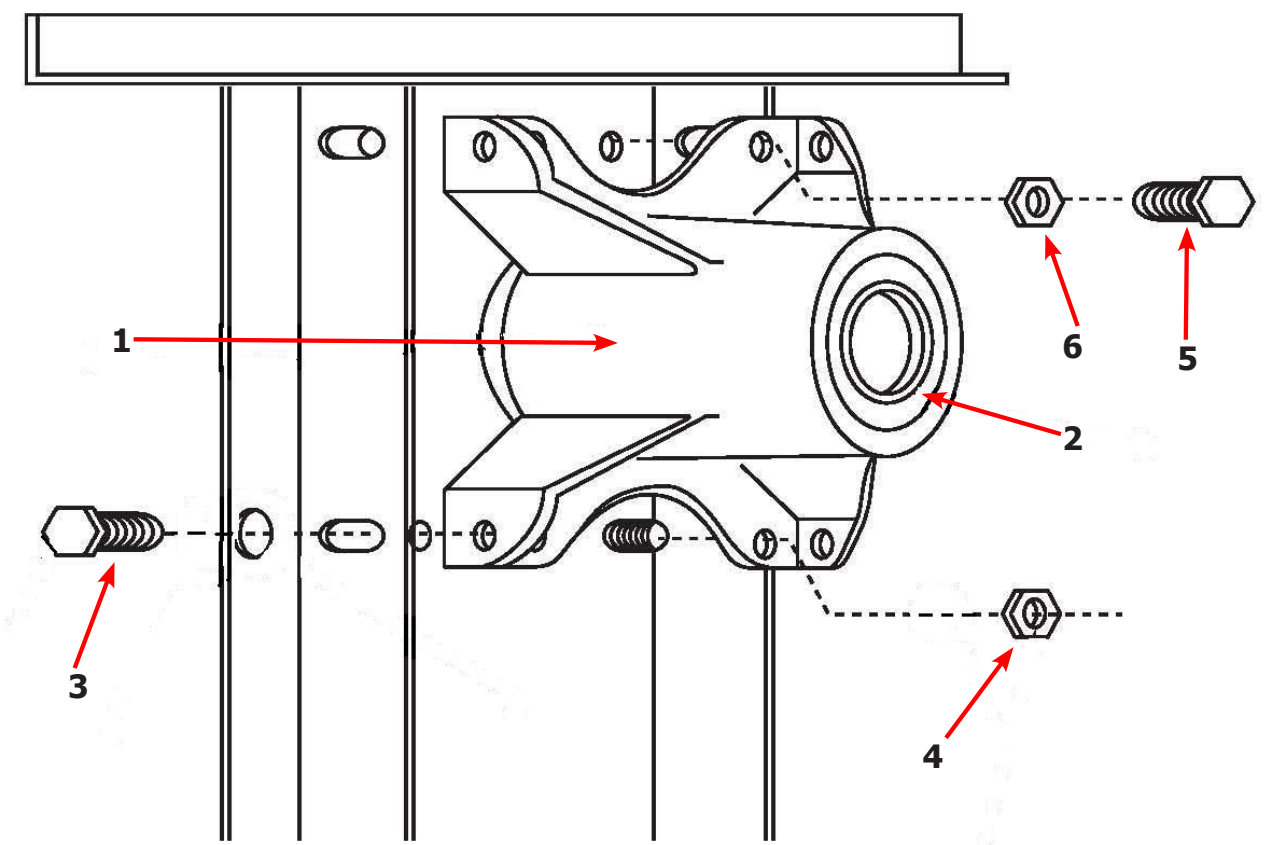
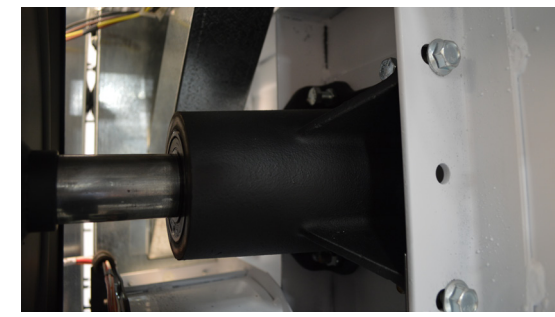
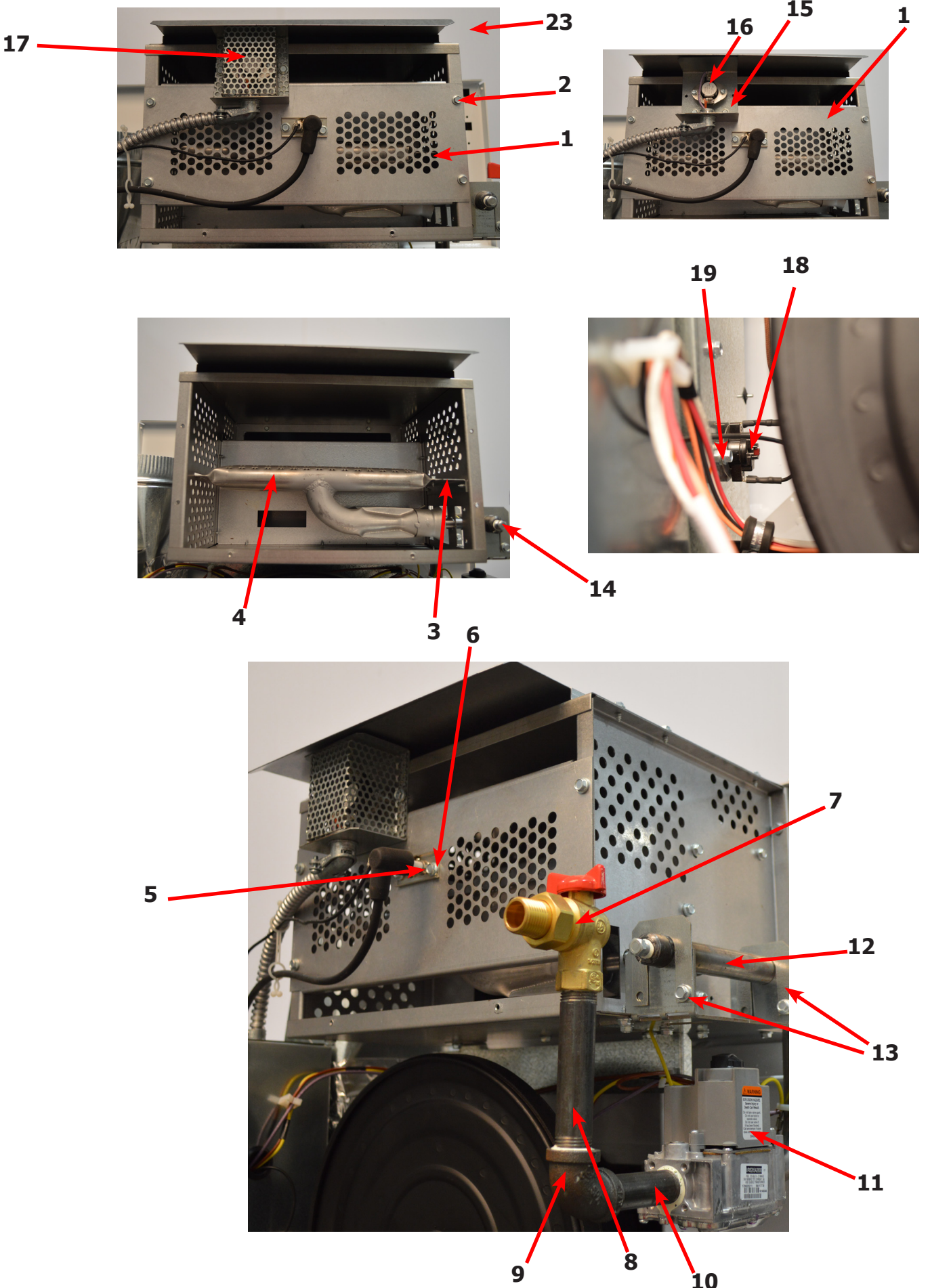

Tumbler Group

Key	Description	T-20 SWD	QTY
*	Tumbler Assy Complete W/Spider (GALV)	9848-156-001	1
1	Tumbler Assy (Galvanized)	9848-155-001	1
*	Tumbler Assy Complete W/Spider (SS & Galv front)	9848-156-002	1
1	Tumbler Assy (Stainless Galvanized front)	9848-155-002	1
2	Rod, Tumbler	9497-019-004	3
3	Washer, Special	8641-554-001	3
4	Shim	9552-013-003	AR
5	Spider Assy	9568-018-001	1
6	Nut, Wiz Lock	8640-415-004	3
7	Spacer-Shaft	9538-164-001	1
8	Tolerance Ring	9487-234-005	1
9	Pulley, Driven	9908-052-002	1
10	Washer -Flat 1/2	8641-581-026	1
11	LockWasher - IntTooth, 1"	8641-582-016	1
12	Screw, 1/2-13x1 1/4	9545-017-009	1
*	Belt, Drive	9040-073-013	2

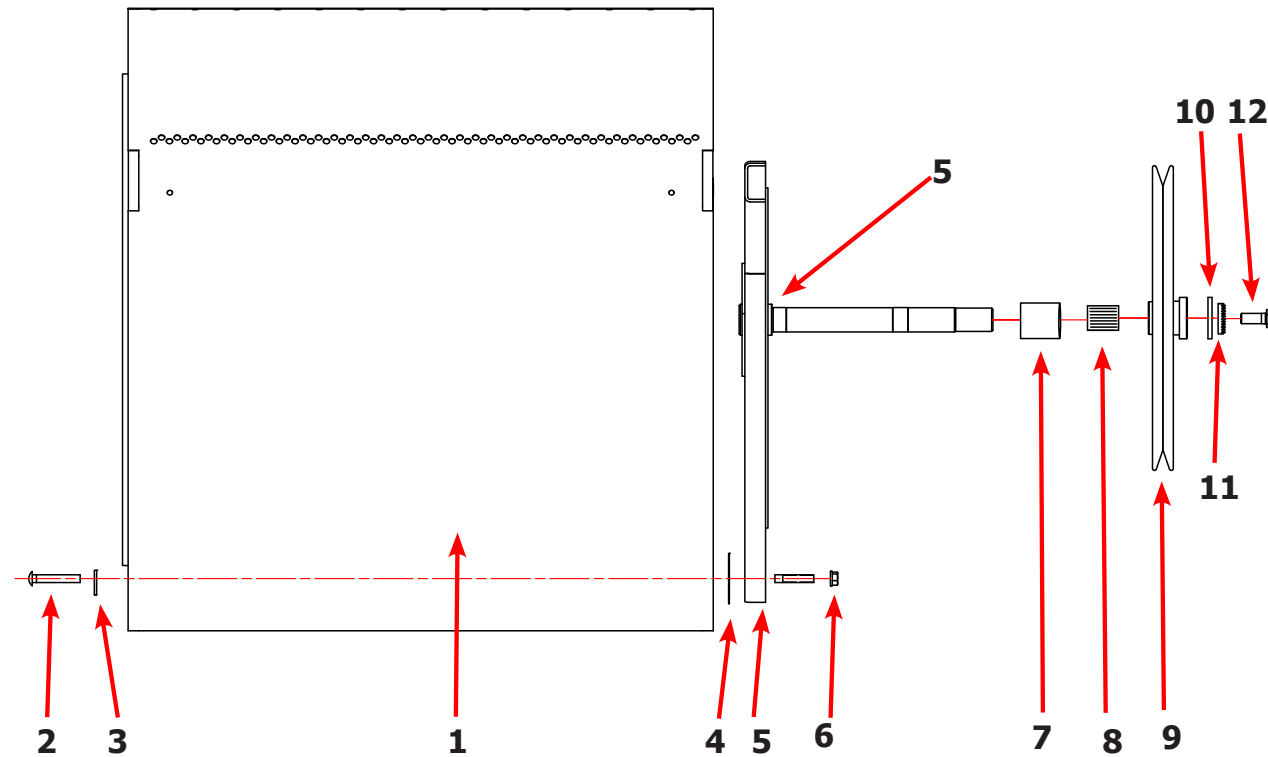

	Description	T-20 SWD	QTY
*	Switch Assy, Air Flow	9801-095-001	1
1	Switch, Air Flow	9539-461-009	1
2	Bracket, Switch- Air Flow	9029-174-001	1
3	Actuator, Switch	9008-007-001	1
4	Pin, Cotter	9451-169-002	1
5	Screw 4-40 x 5/8"	9545-020-001	2
*	Nut, Special Twin .#4-40	8640-401-001	1
*	Shield, Switch	9550-169-003	1
*	Screw 10 Bx 1/4"	9545-008-001	3
6	Motor, Drive	9376-332-001	1
*	Tumble Capacitor	5191-108-005	1
*	Start Capacitor	5191-109-005	1
*	Pulley-motor,60hz	9453-185-001	1
*	Screw-set,5/16-18x1/2	9545-028-013	1
7	Plate, Motor Mtg	9982-390-002	1
*	Bolt 3/8" - 16 x 3/4"	9545-029-008	1
*	Lockwash Spring 3/8	8641-582-003	1
8	Screw, Motor to Plate Screw-hxflgwhzlk,5/16-18x5/8	9545-014-004	4
*	Nut-hextwinwhzlk,5/16-18	8640-400-003	4
9	Nut 1/4x20 Motor Plate to Cabinet	8640-414-007	7
10	Clamp-cable,3/4	8654-125-004	2
*	Screw-hxhdsltdmach,12abx1/2	9545-048-001	2
11	SupportAssy, Intermed. Pulley	9991-053-002	1
12	Bolt, Rd Hd 3/8-16 x 1 1/4	9545-029-010	3
13	Bolt, 3/8-16 x 1 1/2	9545-029-012	1
12	Nut Flange Wizioc 3/8" - 16	8640-415-004	3
*	Washer, Flat	8641-581-035	1
14	Arm Assy-Tension, Complete	9861-022-001	1
*	Washer, Flat	8641-581-035	1

Rear View Photos

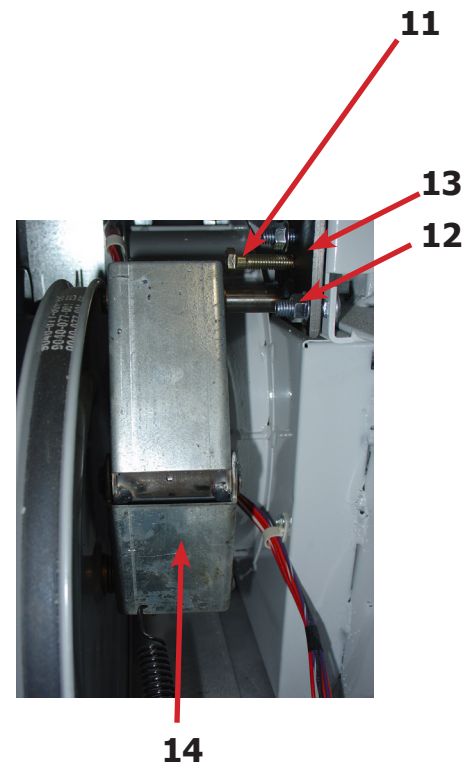
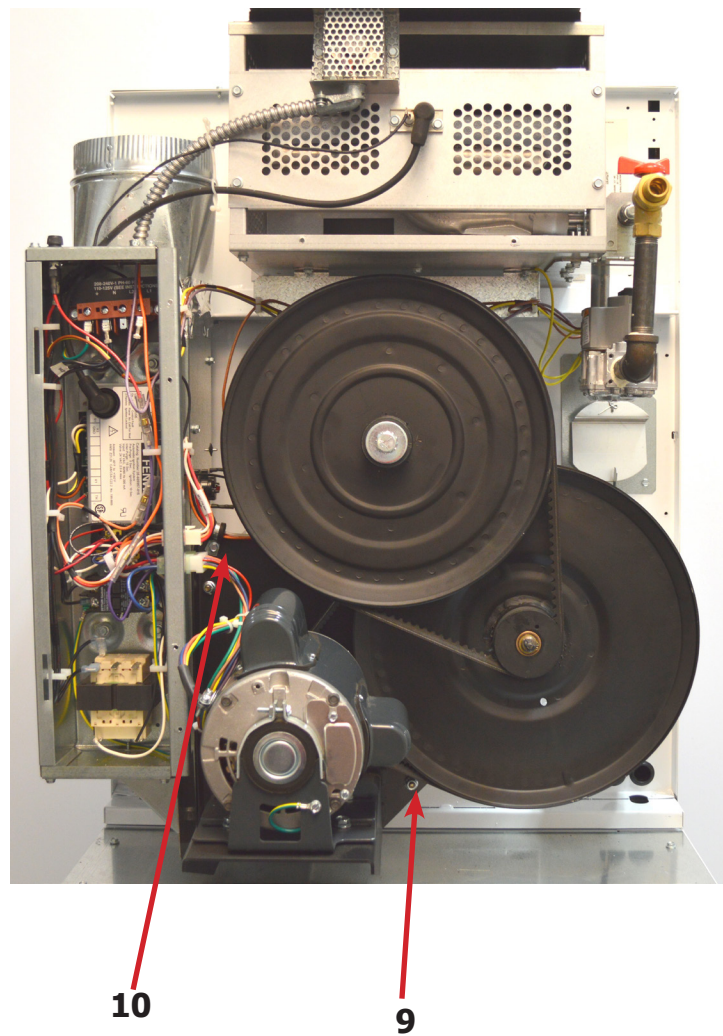
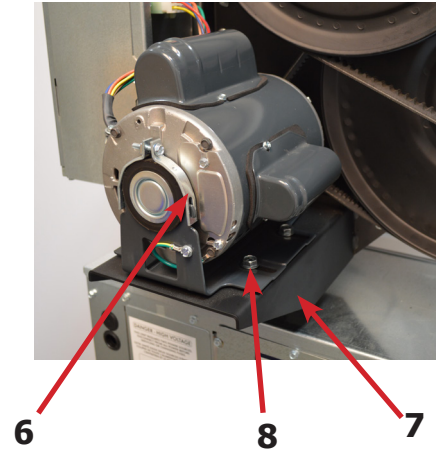
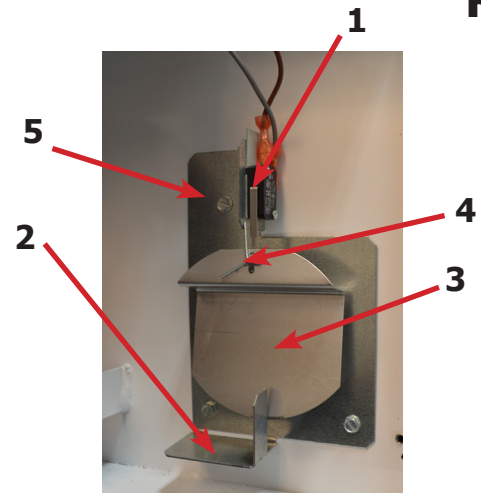

	Description	T-20 SWD	QTY
14	Arm Assy-Tension, Complete	9861-022-001	1
*	Washer, Flat	8641-581-035	1
15	Ring-Retaining	9487-200-003	1
16	Pulley Assy, Intermediate with bronze flange bearing	9908-053-003	1
*	Bearing - Bronze Flange	9036-145-002	1
*	Spacer-Shaft (See Tumbler Group for Expanded View)	9538-164-001	1
*	Tolerance Ring	9487-234-005	1
17	Pulley, Driven	9908-052-002	1
18	Washer -Flat	8641-581-026	1
18	LockWasher - IntTooth, 1/2"	8641-582-016	1
18	Screw, 1/2-13x1 1/4	9545-017-009	1
19	Belt, Drive- Motor	9040-076-012	1
20	Belt, Drive- Tumbler	9040-073-013	1
21	Spring, Tension	9534-319-002	1
22	Chain, Tension	9099-012-011	1
23	Hook, Tension	9248-022-002	1
*	Damper Inside Duct Exhaust	9125-009-001	1
24	Pin, Damper Hinge	9451-146-007	1
*	Box-duct.lower	9041-113-001	1
*	Nut, Spring	8520-141-000	2
*	Screw #10B x 1/2	9545-008-026	3
*	Cover Duct Upper	9074-372-001	1
*	Base Duct	9047-121-001	1
*	Screw 10ABx 3/8"	9545-008-024	40
26	Impeller, W/Set Screws	9278-045-001	1
27	Pulley, Motor	9453-185-001	1
28	Bracket for Wire Harness Under Burner Housing	9029-305-001	1

Rear View Photos

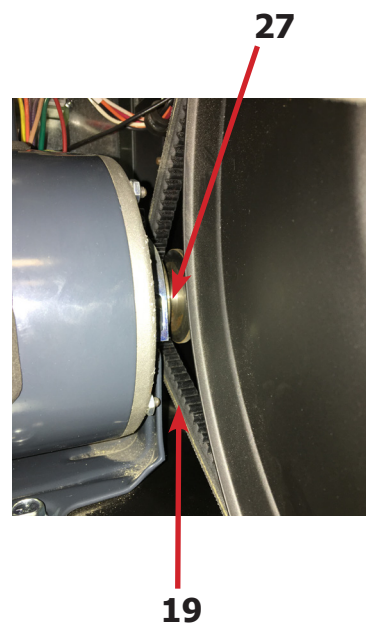
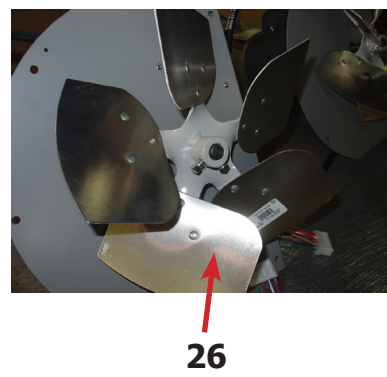
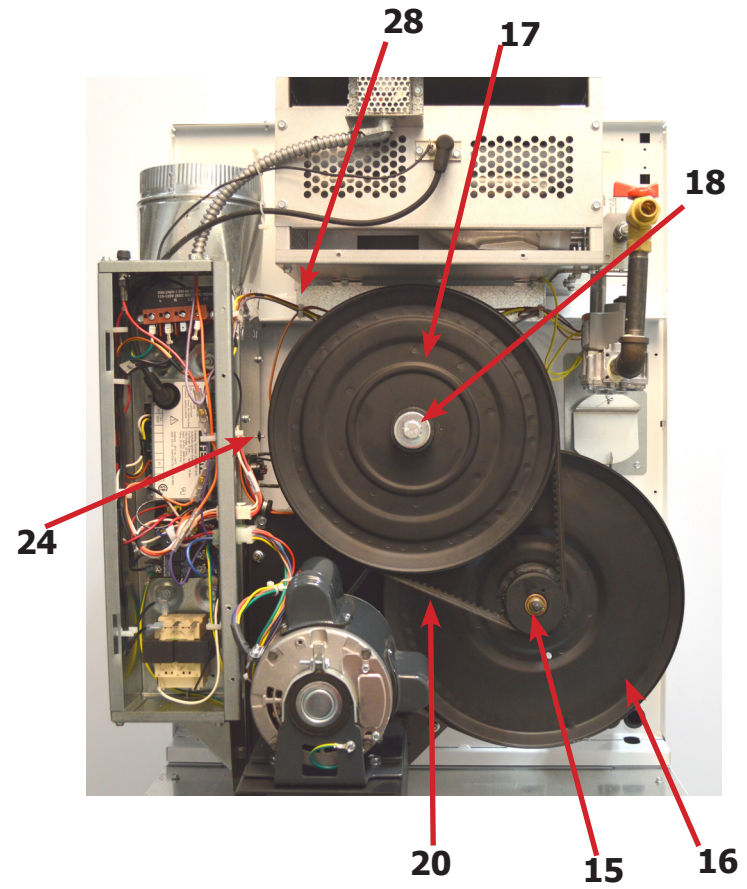
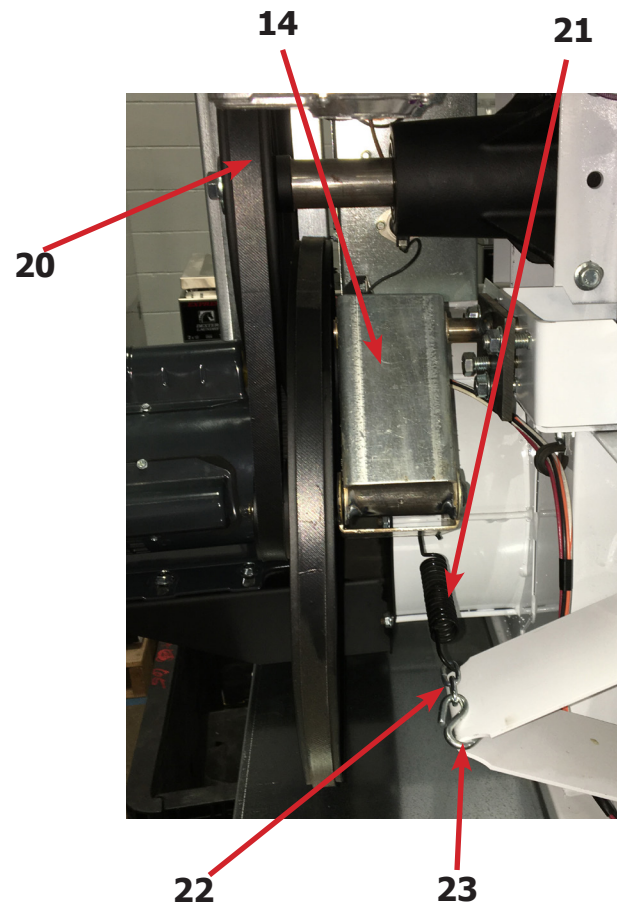

Control Assembly Group

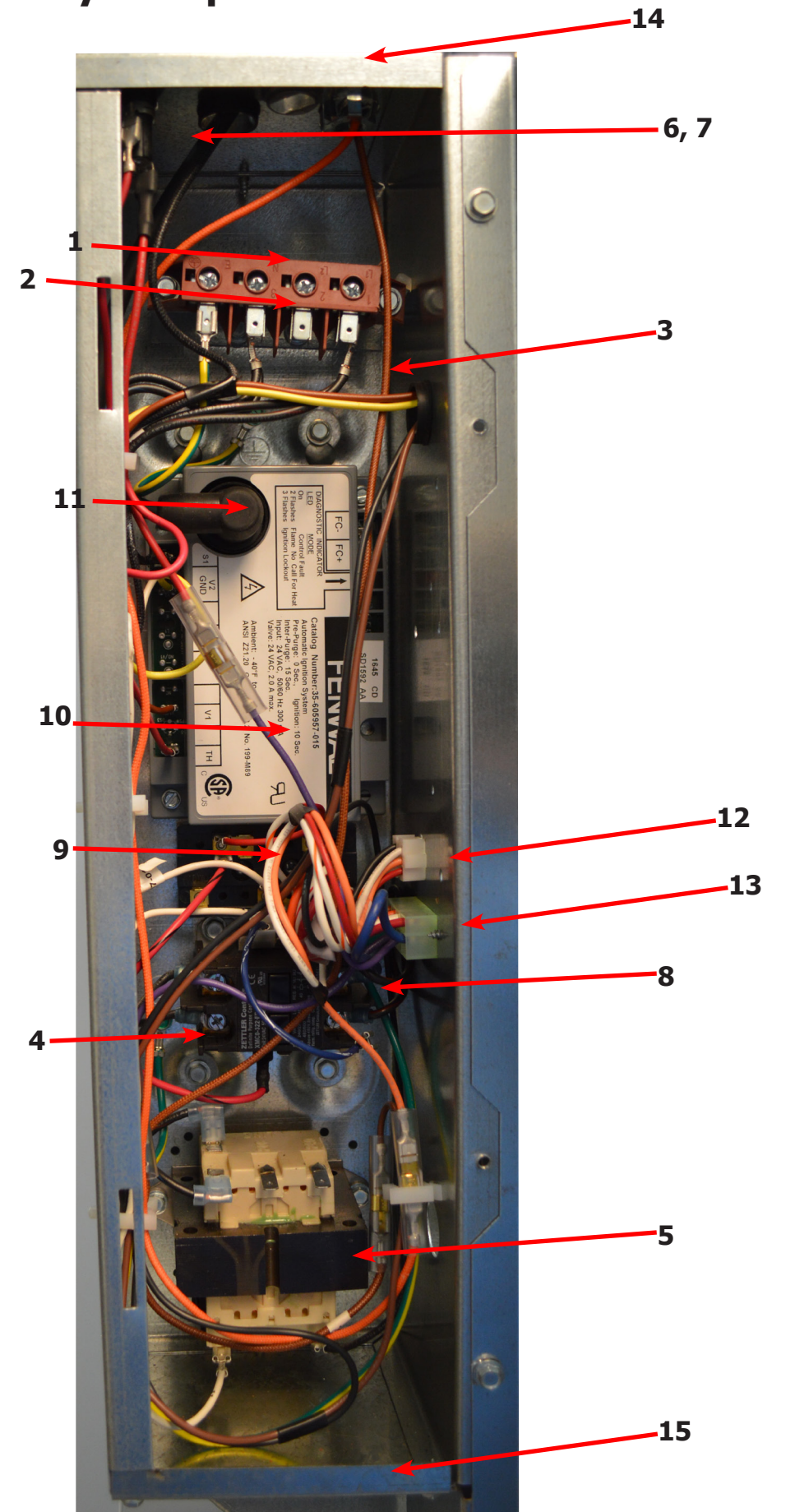

Control Assembly Group

Key	Description	T-20 SWD	QTY
*	Control, Rear	9857-229-001	1
*	Bracket, Terminal Block Power	9029-202-001	1
1	Strip, Terminal Marker	9558-029-003	1
2	Terminal-Block, Power, 4 Pole	9897-035-001	1
*	Screw, 10AB x 3/8"	9545-008-024	6
3	Harness Assembly-Power Main Fork, Upper	9627-859-007	1
4	Wire Assembly-Ground, GRN/YEL, 7"	8220-137-002	1
*	Lock Washer, Ext tooth #10	8641-582-006	1
*	Screw, 10-32 x 1/2"	9545-008-027	1
5	Transformer, 208/240/60Hz. 24/120VA	8711-007-002	1
*	Screw, 10AB x 3/8"	9545-008-024	2
6	Fuse Holder Assembly	9200-001-002	1
7	Fuse, 1.5Amp/250V-Fast Acting	8636-018-001	1
8	Relay, Motor, 30Amp 24VAC	5192-299-002	1
*	Screw, Phillips, 8AB x 1/2"	9545-045-012	2
9	Terminal Block, Power	9897-026-001	1
*	Screw, Phillips, 8AB x 1/2"	9545-045-012	2
*	Harness-Assembly, Low Voltage, Upper	9627-867-011	1
10	Ignition Module	9857-182-001	1
*	Screw, 10AB x 3/4"	9545-008-018	2
11	Wire Assembly, High Voltage	9631-403-009	1
*	Door-Control Box	9108-141-001	1
*	Screw, 10AB x 3/8"	9545-008-024	3
12	Harness, Main (Internal Box)	9627-863-003	1
*	Harness Main Extension (External Box)	9627-913-004	1
13	Harness Motor	9627-864-007	1
14	Control Box Panel Upper	9454-943-001	1
15	Control Box Panel Lower	9454-944-001	1
*	Control Box Wrapper	9636-216-001	1
*	Wire Red/Black 8"	8220-062-047	1
*	Wire White #11, 14"	8220-062-038	1
*	Wire-Blue/White 5.5"	8220-062-026	1
*	Wire Black/Red #9 9"	8220-146-001	1

Door Switch Group

Key	Description	T-20 SWD	QTY
1	Door Switches	9539-487-001	2
2	Bracket-Mounting lint tray switch	9029-297-001	1
3	Conduit-Wire	6068-049-001	1
*	Grommet Wire 1/2 i.d.	9029-089-001	1

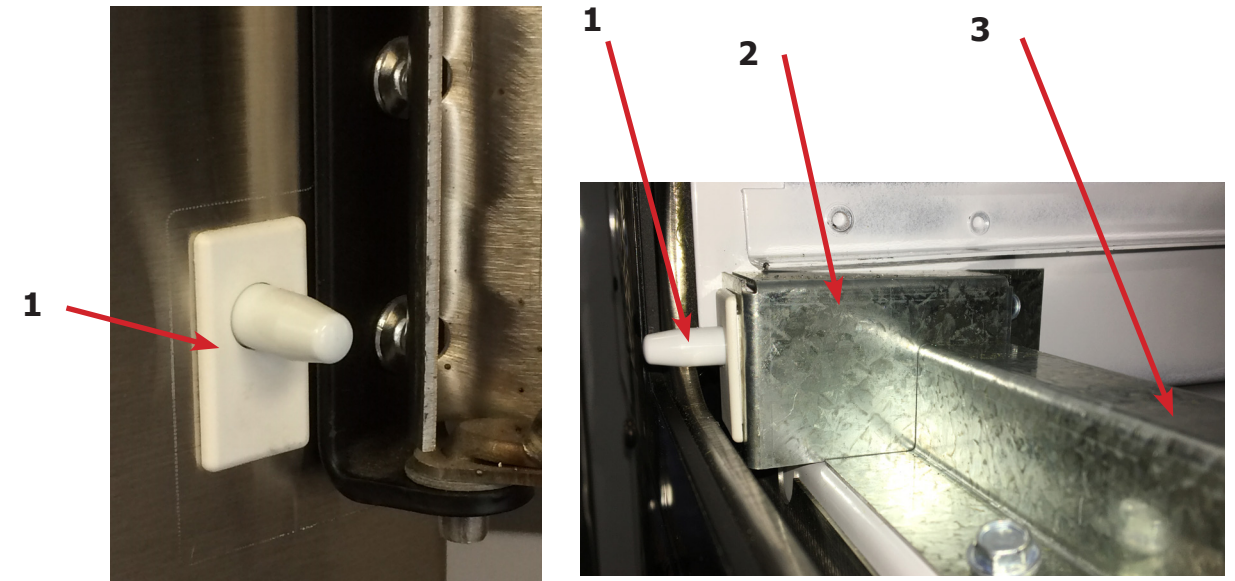

Hinge Plate Cover

Key	Description	T-20 SWD	QTY
1	Cover-Hinge, Black	9074-377-002	1
2	Screw-TRHDCR, 10B x 3/8, Black	9545-008-010	2

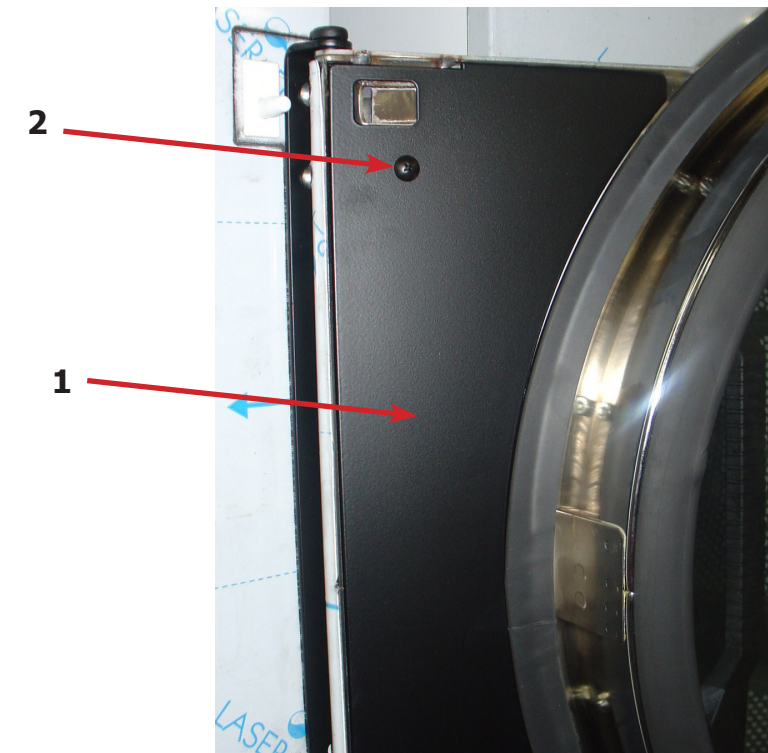

Wiring Schematic 60 Hz

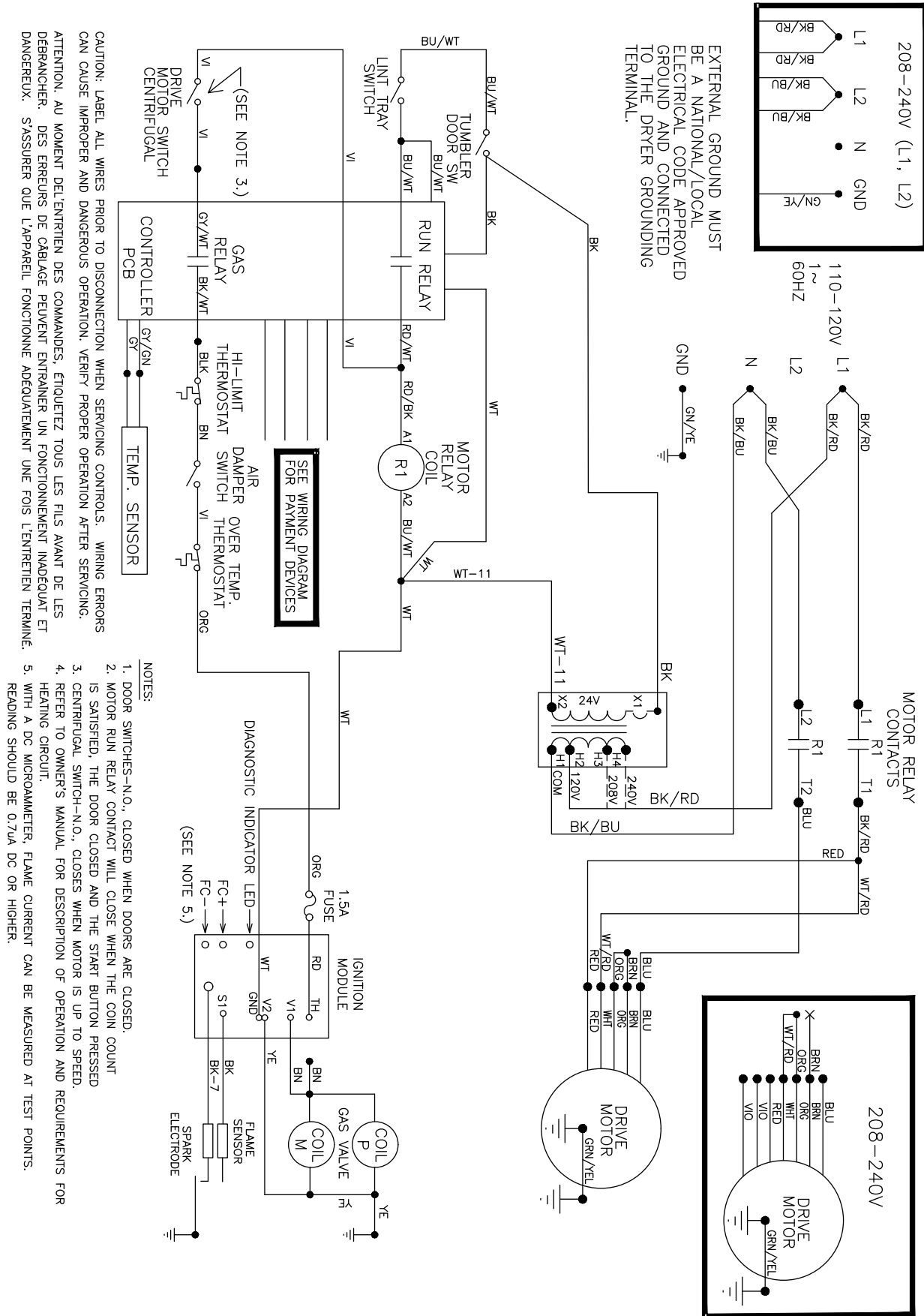

9506-808-001PR

SCHEMATIC

DCS020N_15_C_X- - - - - X

Coin Handling Group

Key	Description	Part Number	Qty
	Coin Acceptor, Optical, SWD, US Quarter	9021-094-001	1
*	Harness-Extention ,Control to Acceptor, Optical Dryer	9627-916-003	1
*	Retainer, Coin Acceptor	9486-145-001	1
*	Screw, Torx	9545-053-002	4
1	Switch Assembly, Optical Sensor, SWD	9801-099-003	1
*	Screw-Height Bar, 3mm	9545-039-002	2
	Below not included		
*	Harness, Acceptor Mechanical (Control to Acceptor)	9627-783-003	1
*	Coin Vault	9942-028-005	1
*	Screw, 10AB X 3/8	9545-008-024	2
*	Bracket-mounting,coinvault	9029-293-001	1

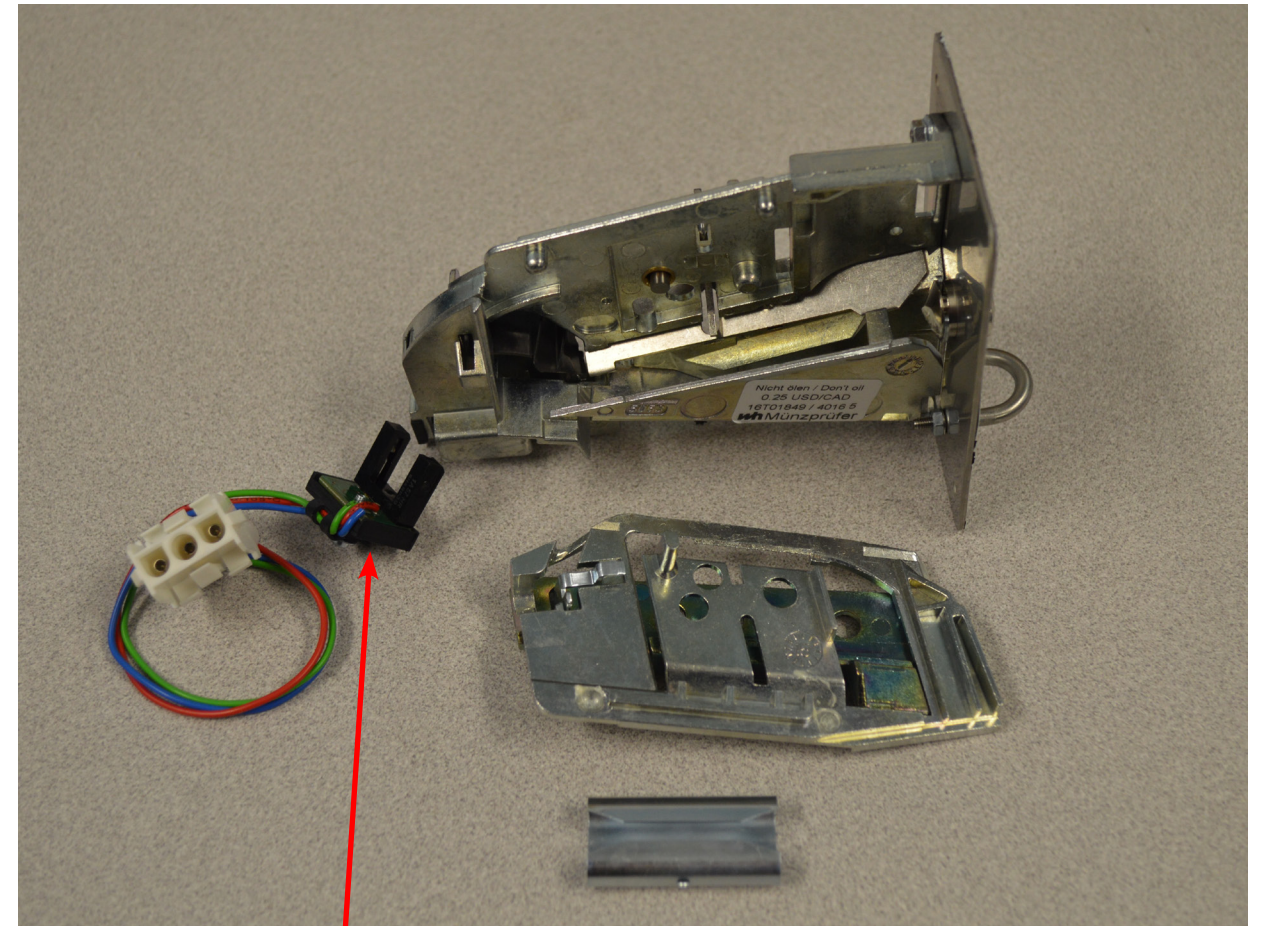

1

-39 T-20 SWD 50 Hz Parts

Key	Description	Part Number	Qty
*	Strip, Terminal Marker -39 Models	9558-029-004	1
1	Transformer	8711-007-002	1
*	Instructions, Transformer Connect	8507-230-003	1
2	Ignition Control -39 Models	9857-182-001	1
*	Harness-Ignition Control,	9627-867-011	1
3	Wire Assembly High Voltage	9631-403-009	1
4	Motor	9376-332-001	1
5	Pulley, Motor Drive	9453-185-002	1
6	Harness Motor Extension	9627-864-007	1
*	Wiring Label Schematic/Diagram -39 models	9506-819-001	1
*	Owner's Manual	8514-280-001	1
*	Lint Drawer Assembly -39 Models	9866-008-002	1

Section 6: 50 Hz Gas Dryer

Dryer Models

Parts in this section used only in these models. All other parts are same as standard 60 Hz pages.

Rear View Photos

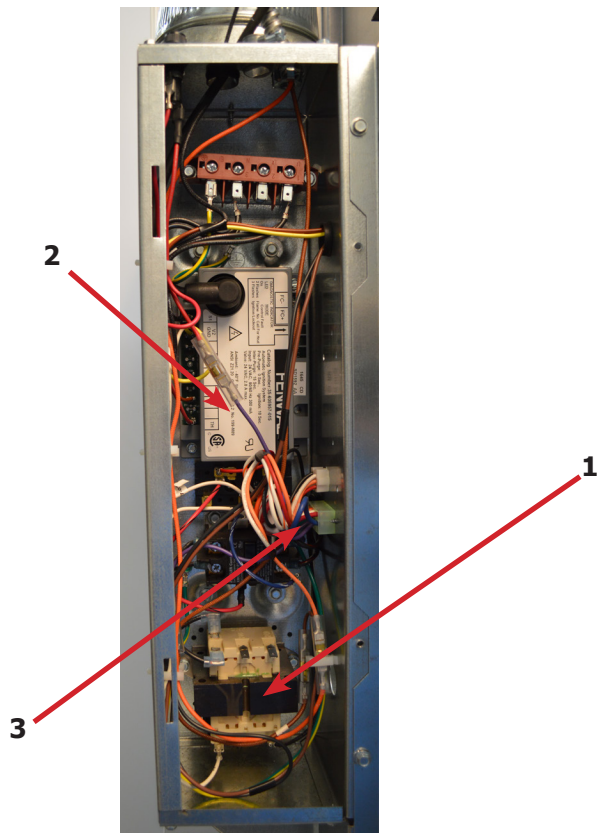
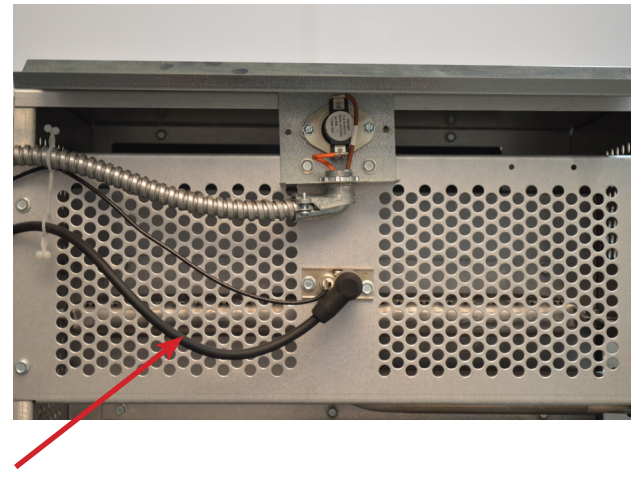
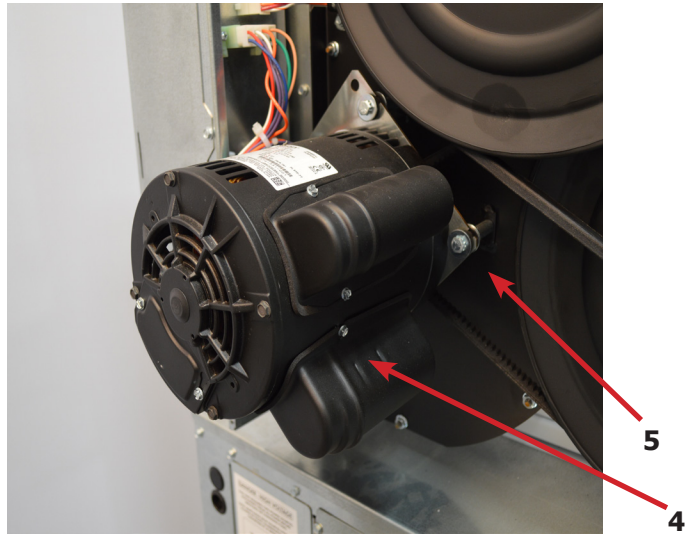

T-20 SWD -39 Gas Control Parts

Key	Description	Part Number	Qty
1	Kit-Honeywell VR86 Valve Flange	9732-162-001	1
*	Orifice, Main Burner #43	9425-069-025	2
2	Gas Control Valve	9857-132-004	1

