



DEXTER[®]
LAUNDRY

**USE THE BLUE TABS LOCATED ON THE
RIGHT AND LEFT SIDES OF THE FOLLOWING
DOCUMENT TO ADVANCE TO EACH SECTION.**

Kits, Assemblies, & Common Parts

Coin Acceptor Components	Part Number
Optical Coin Acceptor	9021-092-002
Optical Sensor Replacement	9801-099-001
Coin Drop Screws	9545-053-002
Retainer, Coin Acceptor	9486-149-001
Loading Door Components	Part Number
Door Handle	9244-093-001
Door Close Switch	9539-487-001
Electrical Components	Part Number
Relay, Motor Run (24VAC)	5192-299-002
Transformer, Ignition/Control (24VAC)	8711-013-001
Controls 24VAC (Blue)	9857-198-002
Controls 24VAC (Black)	9857-198-004
Heating Circuit Components	Part Number
Ignition Control Module	9857-182-001
Ignition Electrode Assembly	9875-002-003
Thermostat, Hi-Limit	9576-203-002
Thermostat, Overtemp	9576-207-008
Fuseholder	9200-001-002
Fuse 1.5 amp	8636-018-001
Airflow Switch	9539-461-009
Cabinet Components	Part Number
Liner, Baffle RH	9354-013-002
Liner, Baffle LH	9354-014-002
Cleanout Duct Assembly 8"	9973-034-001



Section 6:

Parts Data

DC50X2-15

24V Control

Cabinet Group

Key	Part Number	Description	Quantity
*	9960-285-008	Door Assy., Loading Complete-Wht	2
*	9960-285-011	Door Assy., Loading Complete-SS	2
*	9960-285-007	Door Assy., Loading Complete-Chrome/BLK/SS	2
1	9960-284-002	Door Assy., Loading-SS(ring only)	2
1	9960-284-004	Door Assy., Loading-Chrome(ring only)	2
2	9982-353-002	Plate Assy., Hinge (Wht) No Pin	2
2	9982-353-001	Plate Assy., Hinge (SS) No Pin	2
*	9545-012-015	Screw, Hinge to Door	8
*	8640-413-002	Nut, Hinge to Door	8
3	9212-002-004	Glass, Door	2
4	9206-413-002	Gasket, Glass Black	2
*	9548-117-000	Support, Door Glass	2
*	8545-064-001	Tool Install Dryer Door Gasket	1
5	9206-420-005	Gasket, Outer Rim Black	2
6	9244-082-001	Handle, Loading Door	2
*	9545-018-017	Screw, Handle 1/4-20 x 3/8	4
*	9531-033-003	Stud, Door Catch	2
*	8640-413-001	Nut, Hex	2
*	8640-413-003	Nut, Acorn	2
*	9086-015-002	Catch, Loading Door	2
*	8638-190-009	Pop Rivet for mtg. catch	4
*	8641-582-006	Lockwasher	4
*	8640-399-001	Spring Nut (Before Serial D1.21180.036)	8
*	8650-442-001	Expansion Nut (After Serial D1.21180.036)	8
7	9989-521-003	Panel Assy., Front- Lower (Wht)	1
7	9989-521-001	Panel Assy., Front- Lower (SS)	1
8	9989-517-003	Panel Assy., Front- Upper (Wht)	1
8	9989-517-001	Panel Assy., Front- Upper (SS)	1
*	9277-054-001	Insulation Front Panel, half moon (top)	2
*	9277-054-002	Insulation Front Panel, half moon (bottom)	2
9	9545-008-014	Screw, FLHDCR, 10B x 1	14
*	8641-585-001	Lockwasher	6
*	8640-399-001	Nut, Spring (Before Serial)	8
*	8640-442-001	Nut, Expansion (After Serial)	8
10	9544-069-002	Strap, Hinge (Wht)	2
10	9544-069-005	Strap, Hinge (SS/Black)	2
*	9545-012-028	Screw, Hinge to Panel	8
11	9545-052-001	Screw, Door to Hinge Strap (Special Black Type)	2
12	8641-436-003	Washer, Fiber	2
13	9021-041-001	Acceptor, Coin	1
*	9486-149-001	Retainer, Coin Acceptor	2
14	9545-053-002	Screw	4
*	9801-099-001	Switch, Optical	1
*	9472-001-013	Cabinet Touch Up Paint (White)	1

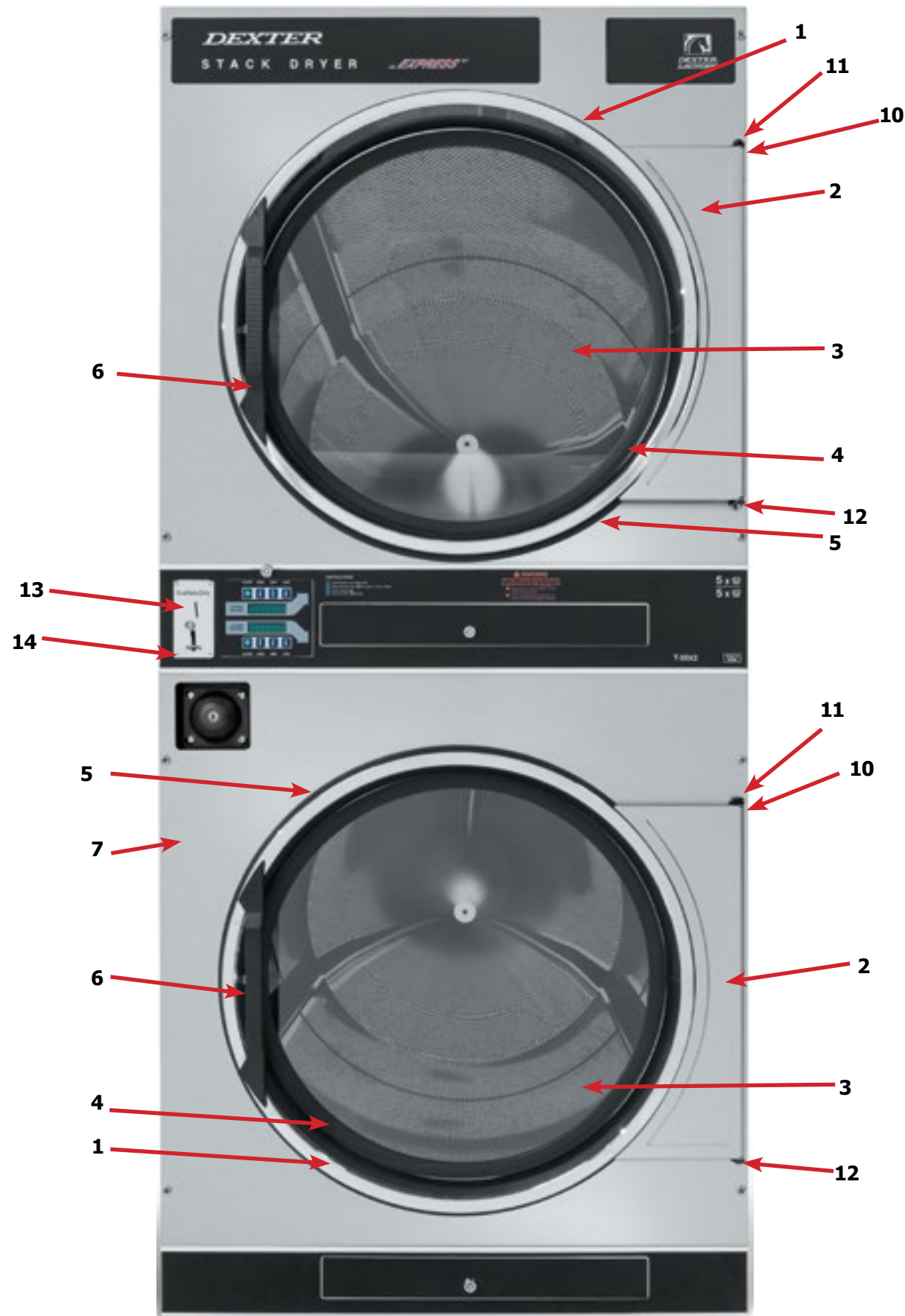

Cabinet Group Continued

Key	Part Number	Description	Quantity
15	9994-049-001	Escutcheon, Upper	1
16	9435-064-002	Trim, Overlay-Upper Blue (After serial D1.19207.001)	1
16	9435-064-001	Trim, Overlay-Upper Black (After serial D1.19207.001)	1
16	9435-039-002	Trim, Overlay-Upper Blue (Before Serial D1.19207.001).....	1
16	9435-039-001	Trim, Overlay-Upper Black (Before Serial D1.19207.001)	1
17	9994-051-001	Escutcheon, Lower	1
18	9435-066-002	Trim, Overlay-Lower Blue.....	1
18	9435-066-001	Trim, Overlay-Lower Black	1
*	9545-020-009	Screw	20
19	9412-167-002	Nameplate Stack Dryer Express Blue.....	1
19	9412-167-001	Nameplate Stack Dryer Express Black	1
20	9866-005-001	Lint Drawer Assembly Blue	2
20	9866-005-004	Lint Drawer Assembly Black.....	2
21	9435-024-001	Overlay Trim, Lint Drwr-Blue	1
21	9435-032-001	Overlay Trim, Lint Drwr-Black.....	1
*	9532-143-001	Felt Seal (back of lint screen assembly)	2
*	9805-039-001	Lint Screen Assembly ONLY (no front)	2
*	9555-057-008	Replaceable Lint Screen Only.....	2
22	8650-012-004	Lock and Key, Lint Drawer	2
*	6292-006-010	Key 6101 only	2
*	9095-043-001	Cam, Lock.....	2
*	9545-008-001	Lint Screen Strap Hold Down Screws 10Bx 1/4	32
23	9857-198-002	Controls Assy, Blue	1
23	9857-198-004	Controls Assy, Black.....	1
*	9627-859-003	Harness, Electronic Control	1
24	8650-012-003	Lock and Key, Control	1
*	9095-041-001	Cam, Lock	1
*	6292-006-007	Key only 6324.....	1
*	9627-855-003	Harness, Heat Sensor	1
*	8640-276-002	Wire Nut Connector Grey.....	4
25	9501-004-003	Sensor Temp Control	2
26	9501-008-001	Bracket for Heat Sensor Mounting (Under Basket) w/ sensor..	2
*	9545-045-005	Screw, Round Head (Mounts sensor; phillips head).....	2
*	9209-037-002	Gromm.et, 3/16 ID	2
*	8544-006-001	Leg, Leveling 1/2"	4
*	8545-061-002	Leveling Leg Wrench	1
*	9074-320-001	Cover, Cabinet (Top)	1
*	9277-041-017	Insulation Cabinet Cover	1
*	9732-276-001	Kit for Dryers without Neutral and using 208-240 volt	1
*	9732-102-013	LP Kit for 50Lb Stk Dryers.....	1
*	9732-243-001	Stack Dryer Trunion Puller.....	1
*	9544-041-002	Strap - Bead Tie	1
27	9942-038-005	Vault, Coin Box	1
*	9545-008-024	Screws, Mounting-Coin Vault	2
28	9897-099-002	Coin Box Assy, Large Blue	1
28	9807-099-004	Coin Box Assy, Large Black	1
*	8640-413-004	Nut, Elastic Stop.....	

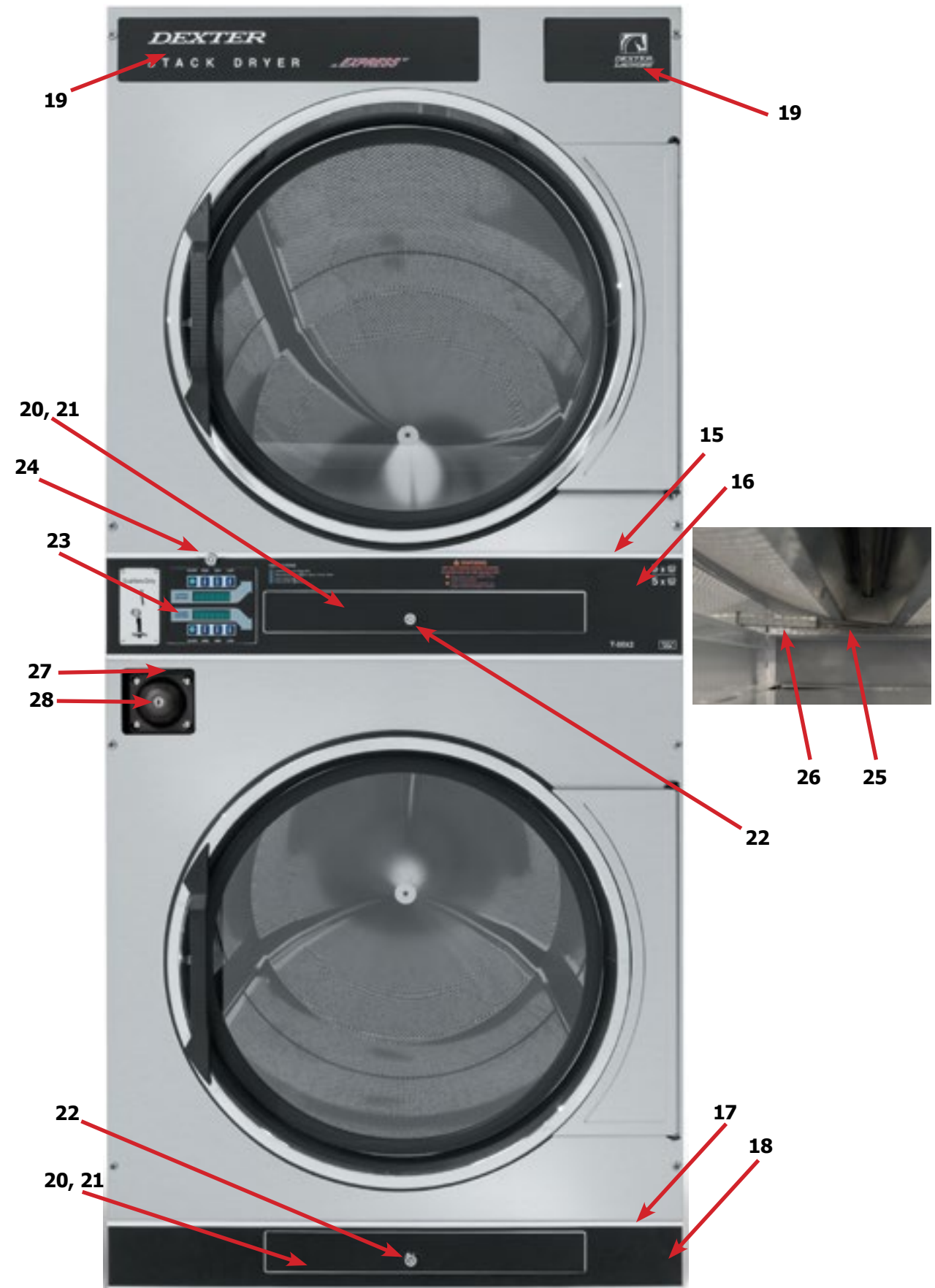

Control Parts Group

Key	Part Number	Description	Quantity
*	9857-198-002	Controls Assy, Electronic Mounted With Membrane Switch, BLU...	1
*	9857-198-004	Controls Assy, Electronic Mounted With Membrane Switch, BLK...	1
1	9826-008-001	Trough Assembly	1
2	9035-062-002	Button-Push, Control, Black	2
2	9035-062-001	Button-Push, Control, Blue	2
3	9538-166-011	Spacer-Metal, 4mm	4
4	9486-158-001	Retainer-Push Button	2
5	8640-424-002	Nut-Hex, Elastic stop, #4-40	4
6	8652-130-038	Terminal-Grounding clip	1
7	9534-365-001	Spring-Flat, Control	1
8	9545-008-001	Screw-Hex, #10B x 1/4	2
9	9545-044-010	Screw-Hex, #10B x 1/4	10
9	8641-582-005	Washer-External tooth, #6	10
10	9435-038-001	Overlay-Control, Coin, Black	1
10	9435-038-002	Overlay-Control, Coin, Blue	1
11	9021-041-001	Acceptor-Coin, Optical	1
*	9486-149-001	Retainer, Coin Acceptor	1
12	9545-053-002	Screw	4
*	9801-099-001	Optical Sensor, Replacement.....	1

Note: Jumpers required if using 1.5 Control on Older Machines (P9 Connection)

*	8220-155-001	Wire Assy, Jumper, 30Lb Stack Coin	1
*	8220-155-002	Wire Assy, Jumper, 50Lb Stack Coin	1

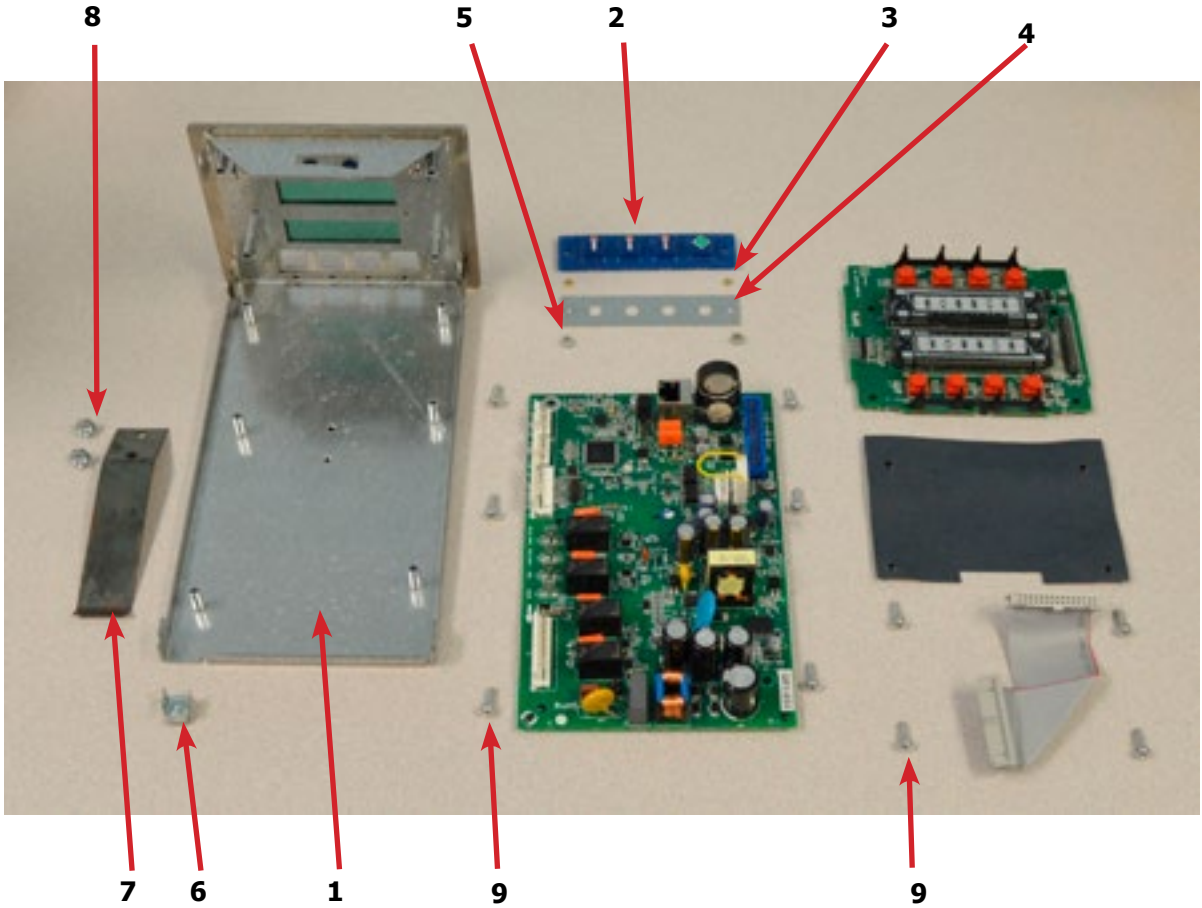

Door Switch Group

Part Number	Description	Quantity
9539-487-001	Door Switches	2

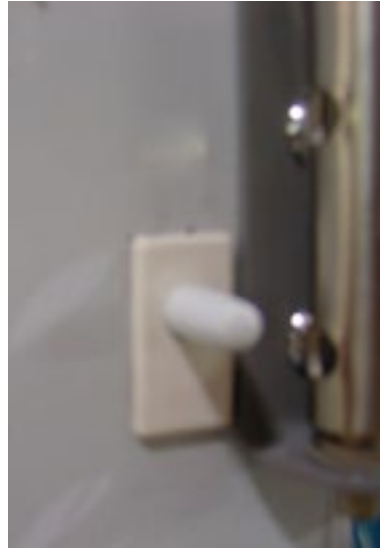

Hinge Plate Cover

1	9074-340-002	Cover-Hinge, Black	2
2	8636-008-010	Screw-TRHDCR, 10B x 3/8, Black.....	4

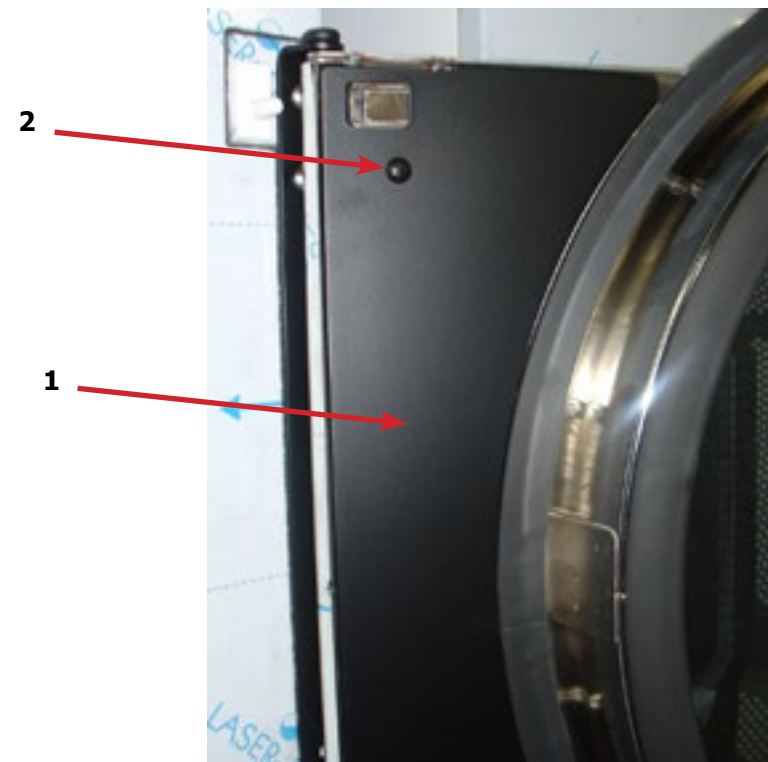

Bearing Housing Group

Key	Part Number	Description	Quantity
1	9241-189-002	Housing, Bearing	2
2	9036-159-003	Bearing, Ball Rear.....	2
*	9538-183-001	Spacer, Bearing	2
*	9036-159-001	Bearing, Ball Front.....	2
5	9545-017-017	Bolt, 1/2 x 3/4.....	8
7	8640-417-002	Nut, 1/2	8
*	9803-201-001	Bearing Housing Complete Ass'y (includes bearings,spacer)	2
4	9545-017-018	Screw 1/2 x 1 1/2	4

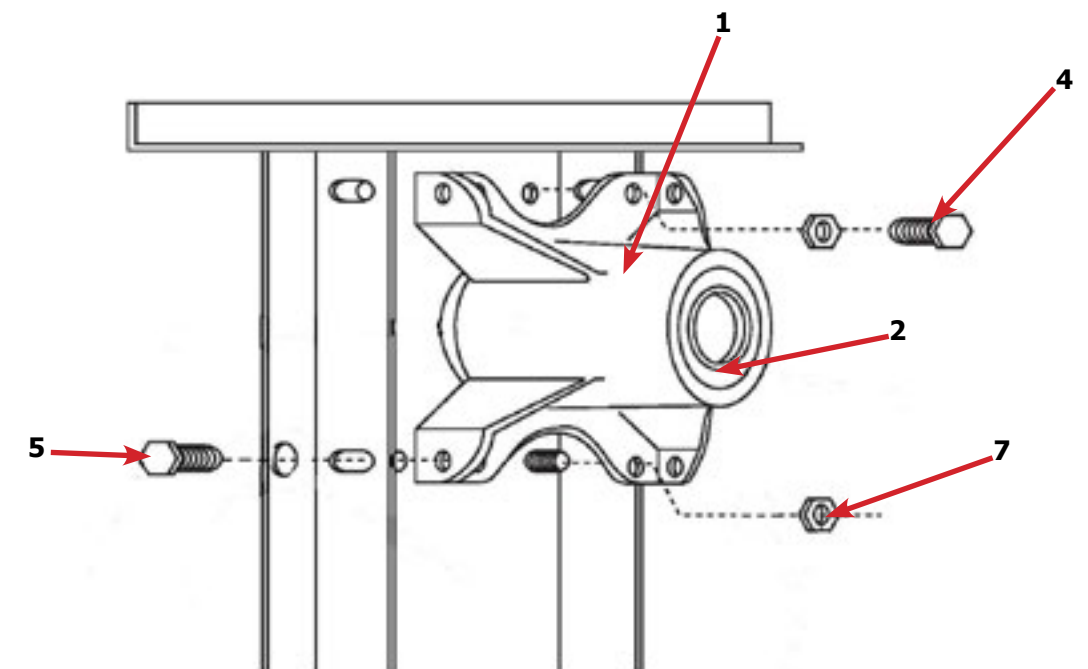

Burner Housing Group

Key	Part Number	Description	Quantity
*	9803-207-001	Housing Assembly, Burner	2
1a	9454-992-001	Panel, Back Burner Housing.....	2
1	9452-729-001	Service Plate baffle Recirculation Chamber Clean Out	2
*	9545-008-006	Screws	8
2	9545-008-001	Screw	16
18	9003-220-001	Angle, Burner Support	2
*	9545-008-006	Screw	4
17	9048-020-002	Burner, Main	4
*	9545-008-006	Screw 10AB x 3/8"	4
4	9545-008-001	Screw 10B x1/4"	8
5	9875-002-003	Electrode Assy, Ignition	2
19	9545-045-001	Screw, Electrode Mtg 8B x 1/4".....	4
7	9379-186-001	Valve, Gas Shut Off (Optional)	1
8	9857-134-001	Control Assy, Gas HoneyWell (before SN# D1.19217.001)	2
8	9857-192-001	Control Assy, Gas White Rogers (After SN# D1.19217.001) ..	2
9	9381-012-001	Manifold, Assy	2
*	9425-069-021	Orifice, Burner-Natural #27	4
*	9425-069-022	Orifice, Burner-LP #44.....	4
10	9029-175-001	Bracket, Manifold.....	2
22	8615-104-038	Pipe Plug in end of Burner Manifold	2
*	9545-008-006	Screw	4
12	9576-203-002	Thermostat, Hi-Limit	2
*	9538-142-001	Spacer, Hi-Limit	4
*	9545-045-007	Screw 8B x 3/4".....	4
13	9074-329-001	Cover, Hi-Limit Stat Ignitor	2
*	9545-008-006	Screw	6
*	9576-207-008	Thermostat, Safety Shutoff	2
*	9545-008-006	Screw	4
15	9825-062-001	Cover, Safety Stat	2
*	9545-008-024	Screw	6
16	9857-116-003	Control, Ignition Fenwall (3 trybox)	2
*	9732-102-013	Kit, LP Conversion 50Lb Stack Kit (HoneyWell).....	2
*	9732-102-045	Kit, LP Conversion 50Lb Stack Kit (White Rogers).....	2
*	9838-018-003	Welded One Piece Gas Pipe Assembly.....	1
*	9732-360-003	Gas Pipe Assembly Replacement Kit.....	1
*	9838-023-003	Gas Pipe Assembly (After Serial D1.23003.011).....	1
*	8615-120-001	Fitting - 1/2 NPT Union Adapter	1
*	9452-730-001	Burner tube service plate (Old Style Burner)	2

Burner Housing Group Photos

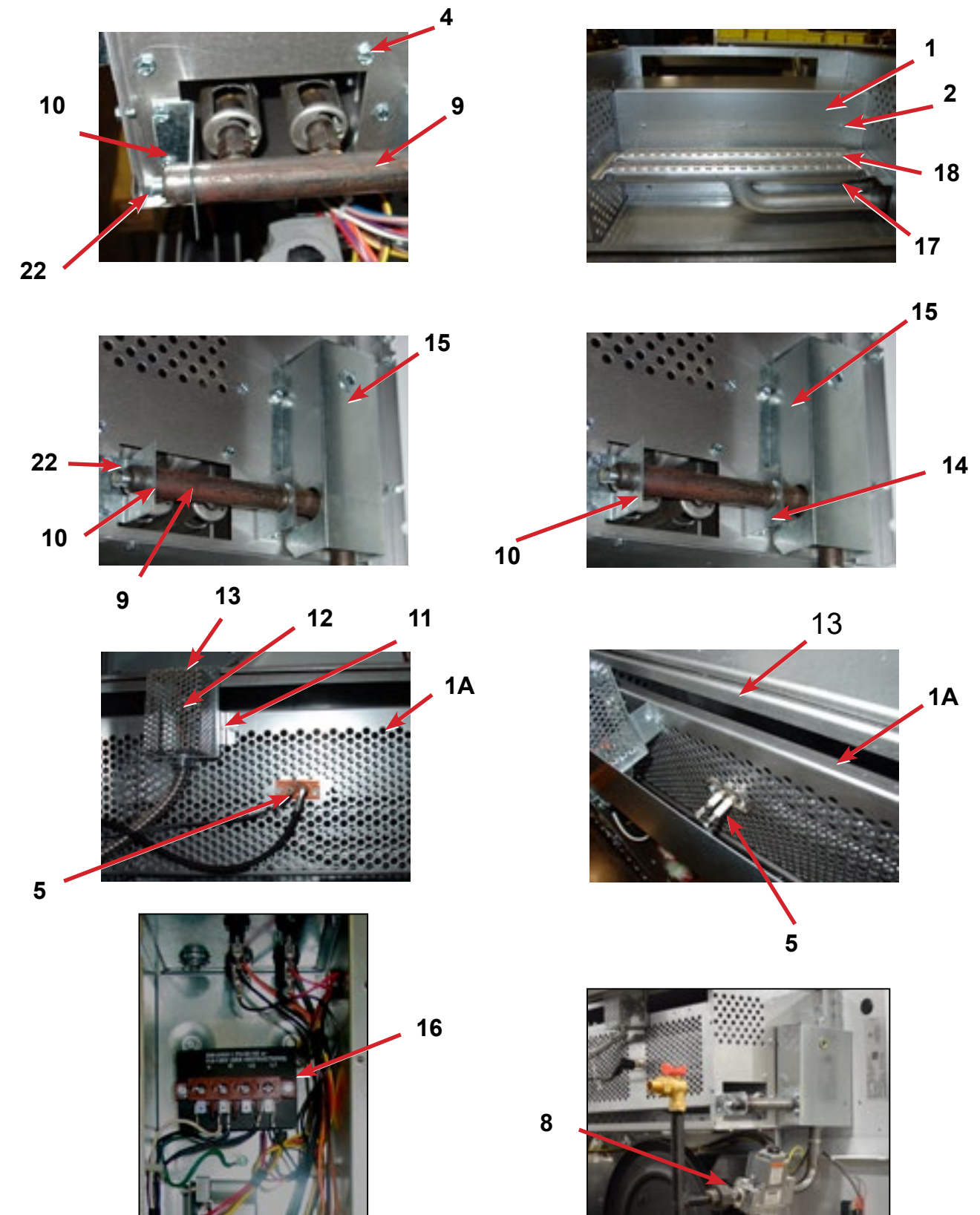

Rear View

Key	Part Number	Description	Quantity
*	9627-861-001	Wire Harness Overtemperature Switch/Air Switch.....	2
*	9801-098-001	Switch Assy, Air Flow	2
1	9539-461-009	Switch, Air Flow	2
2	9029-200-001	Bracket, Switch- Air Flow	2
3	9008-007-001	Actuator, Switch.....	2
4	9451-169-002	Pin, Cotter	2
5	9545-020-001	Screw 4-40 x 5/8"	4
*	8640-401-001	Nut, Special Twin #4-40	2
*	9550-169-003	Shield, Switch	2
6	9376-322-001	Motor, Drive	2
*	9732-205-027	Motor Kit.....	1
*	5191-108-002	Run Capacitor.....	1
*	5191-109-002	Start Capacitor.....	1
7	9452-770-001	Plate, Motor Mounting	1
*	9545-029-008	Bolt 3/8" - 16 x 3/4".....	8
*	8641-582-003	Lockwash Spring 3/8	8
8	9545-018-019	Screw, Motor Plate to Back Assy. 1/4-20x 2 1/2.....	8
*	8641-582-007	Lockwasher 1/4.....	8
9	9538-163-006	Spacr.....	8
*	8641-581-017	Flat Washer 1/4 x 7/8.....	24
*	9209-086-002	Rubber Grommet.....	8
*	9538-166-006	Grommet Spacers.....	8
*	9545-028-013	Screw, Set.....	4
10	9962-018-002	Back Assy, Blower Hsg.....	2
11	9991-053-001	Support Assy, Intermed. Pulley	2
12	9545-029-010	Bolt, Rd Hd 3/8-16 x 1 1/4	6
12	8640-415-004	Nut Flange Wizlock 3/8" - 16.....	6
12	8641-581-035	Washer, Flat	6
13	9545-029-003	Bolt, 3/8-16 x 1 1/2	2
14	9861-022-001	Arm Assy-Tension, Complete	2
*	9487-200-003	Ring-Retaining	6
15	9908-048-003	Pulley Assy, Intermediate with bronze flange bearing	2
*	9036-145-002	Bronze Flange Bearing	4
16	9908-047-002	Pulley Driven Tumbler	2
17	9040-076-009	Belt, Drive Motor.....	2
18	9040-073-011	Belt, Driven Intermediate to Tumbler	2
19	9534-151-000	Spring, Tension	2
20	9099-012-005	Chain, Tension	2
21	9248-022-002	Hook, Tension	2
*	9451-146-001	Pin, Damper Hinge	2
*	9074-334-001	Cover Duct Upper	1
22	9973-032-001	Heat Recirculation Assembly Duct	2
*	9453-169-013	Motor Pulley - Driver	1
*	9545-028-013	Set Screws	2
*	9278-043-001	Impeller	2
23	8641-581-026	Washer, Flat 1/2" for Tumbler Pulley.....	2
24	9545-017-009	Bolt, 1/2"-13 x 1 1/4.....	2
25	8641-582-016	Washer, Star 1/2" for Tumbler Pulley	2
*	9545-008-001	Screw 10 Bx 1/4"	6
*	9545-014-004	Bolt, 5/16-18 x 5/8"	8
*	8640-400-003	Nut, 5/16-18	8
*	9538-184-001	Spacer, Shaft	2
*	9487-234-005	Ring Tolerance.....	2
*	9125-007-001	Damper Inside Duct Exhaust	2
*	9125-007-002	Damper Inside Duct Exhaust	1
*	8520-141-000	Nut, Spring	4
*	9074-335-001	Cover Duct Lower	1
*	9545-008-024	Screw 10ABx 3/8"	72
*	9029-173-001	Bracket for Wire Harness Under Burner Housing	2

Rear View Photos

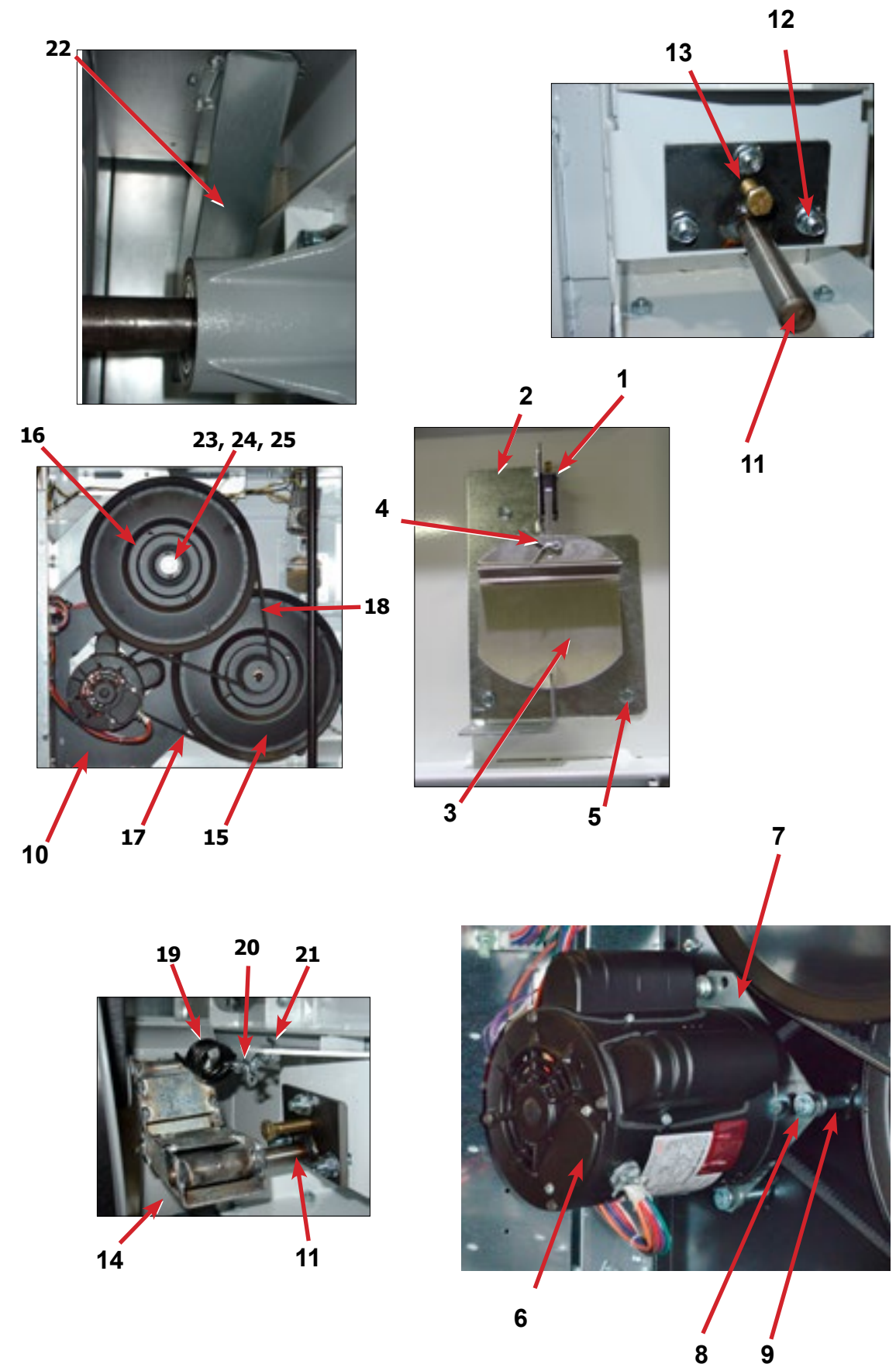

Control Assembly Group

Key	Part Number	Description	Quantity
*	9857-189-008	Control Assmby Complete (all below included)	1
*	9074-317-001	Control Box Cover	1
1	8653-068-003	Connector Conduit 3/8" STR	1
2	9558-031-001	Strip Terminal Marker (Behind Input Power) to above #3	1
3	9897-035-001	Terminal Block Assembly Main Power Inlet	1
*	9545-008-024	Screws 10AB x 3/8"	4
*	9627-859-003	Wire Harness - Power Main	1
4	8220-001-478	Wire Assembly Green 7"	1
5	9545-008-027	Screw # 10-32 x 12 Green	1
*	8641-582-006	Lockwasher Ext Tooth #10	1
6	9897-026-002	Terminal Block Main Power Middle	1
7	9897-026-001	Terminal Block	2
*	9545-045-012	Screw #8 ABx1 2 for terminal block	6
8	8711-013-001	Transformer Control	1
*	9545-008-024	Screws 10AB x 3/8"	4
9	9857-182-001	Ignition Control	2
*	9545-008-018	Screws 10AB x 3/4"	4
10	9631-403-009	Wire Assembly High Voltage Upper	1
11	9627-867-005	Wire Harness Ignition Control Upper	1
12	9631-403-008	Wire Assembly High Voltage Lower	1
13	9627-867-006	Wire Harness Ignition Control Lower	1
*	9053-067-002	Bushing Wire 7/8"	4
14	9200-001-002	Fuseholder Assembly	3
*	8636-018-001	Fuse 1.5 Amp	2
*	8636-018-004	Fuee 2.5 Amp	1
15	5192-299-002	Relay Power	2
*	9545-045-012	Screws Power #8 AB x 1/2"	4
*	8220-062-036	Wire Assembly Red/Black 14"	1
*	8220-062-037	Wire Assembly Red/White 14"	1
16	9627-864-006	Wire Harness Motor Extension	2
17	9527-007-001	Stand Off - Wire Saddle / Arrowhead	5
18	9627-953-001	Wire Harness Main Extension Access Under Burner Housing	4

Control Protection Fuse 2.5 Amp **14** Ignition Upper Pocket Protection Fuse 1.5 Amp **14**



Not Shown:
24VAC Ignition
Lower Pocket
Protection Fuse

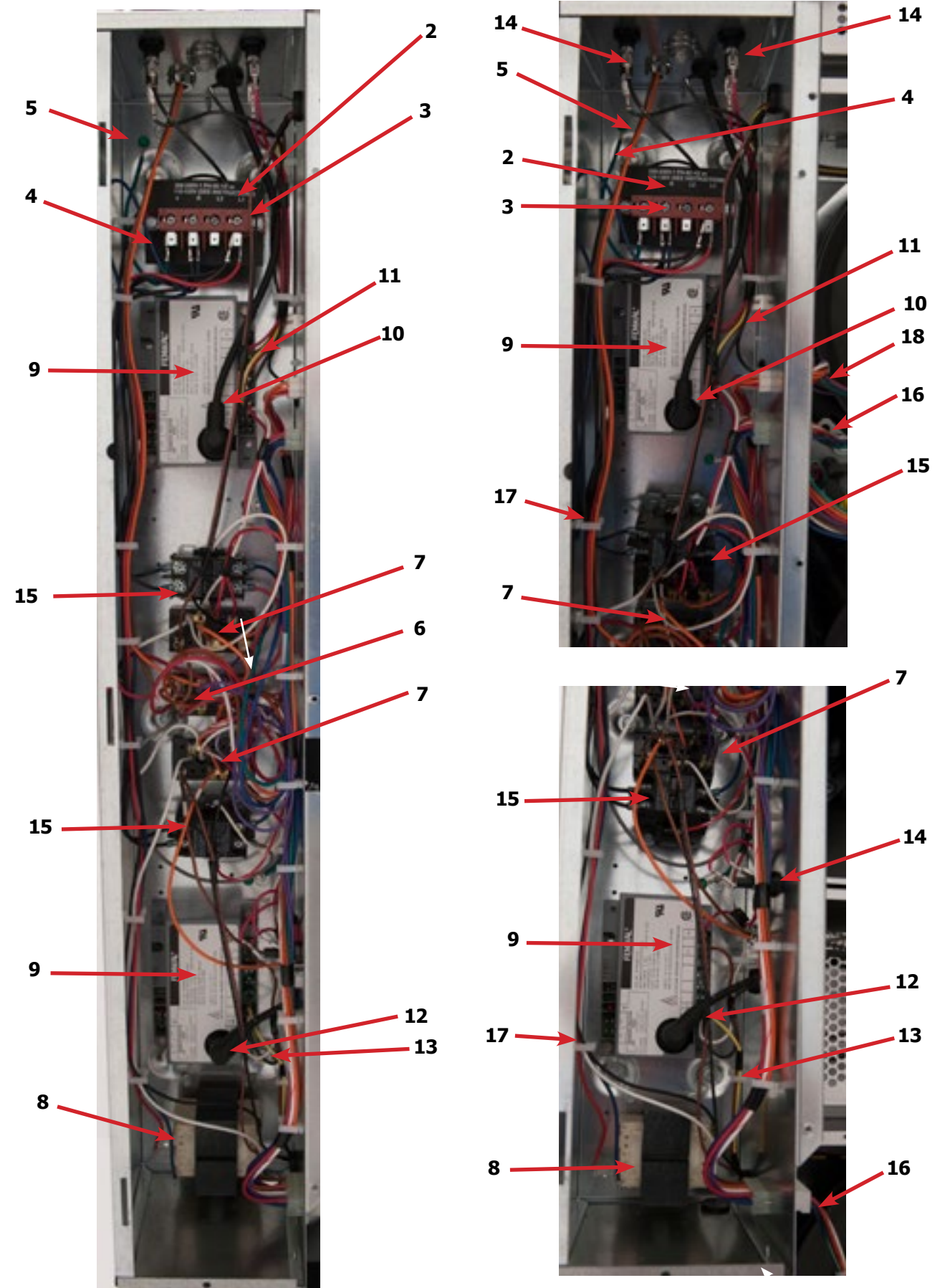

Wiring Schematic for DC50x2

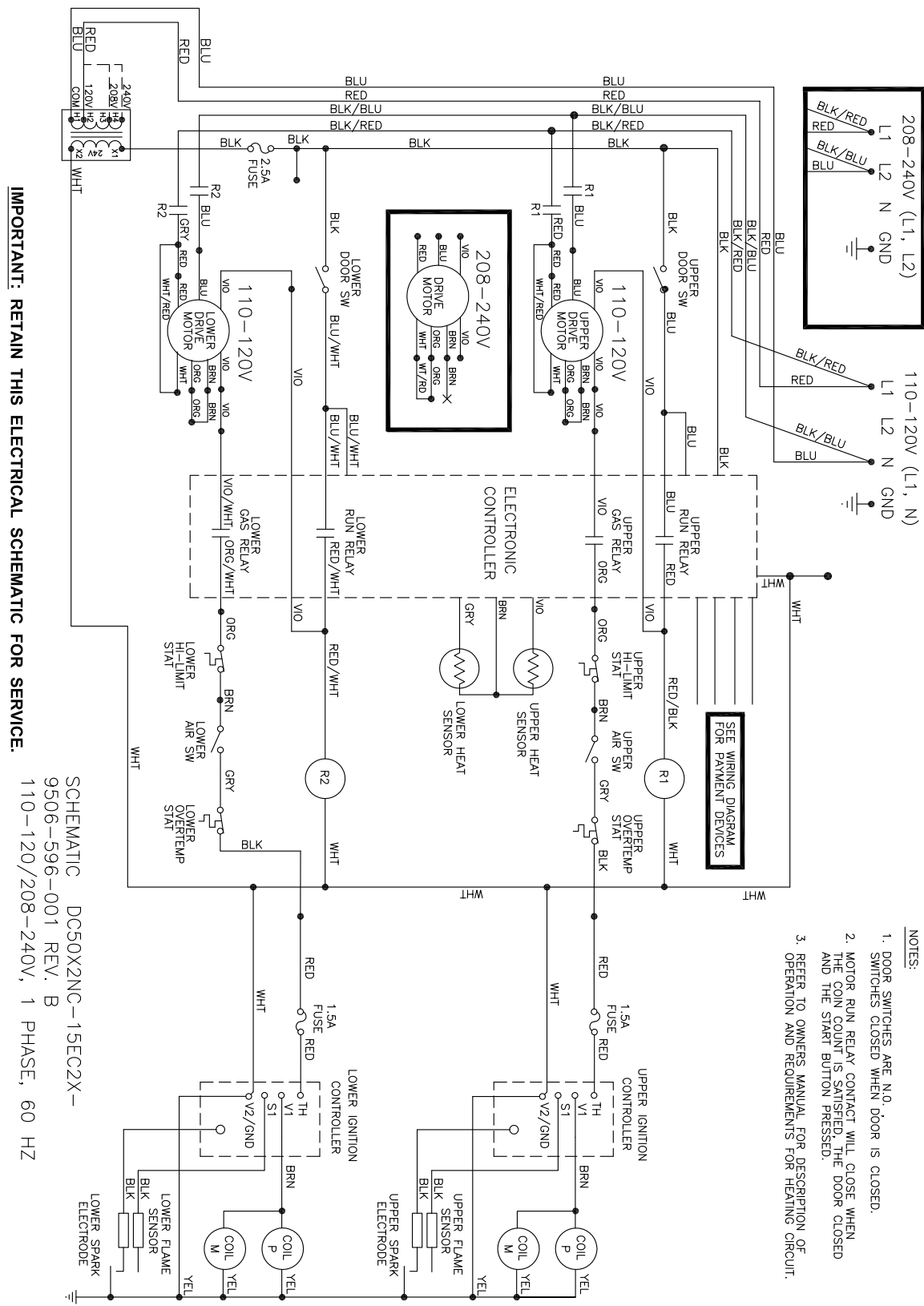

SCHEMATIC DC50X2NC-15EC2X-
9506-596-001 REV. B
110-120/208-240V, 1 PHASE, 60 HZ

Wiring Diagram for DC50x2

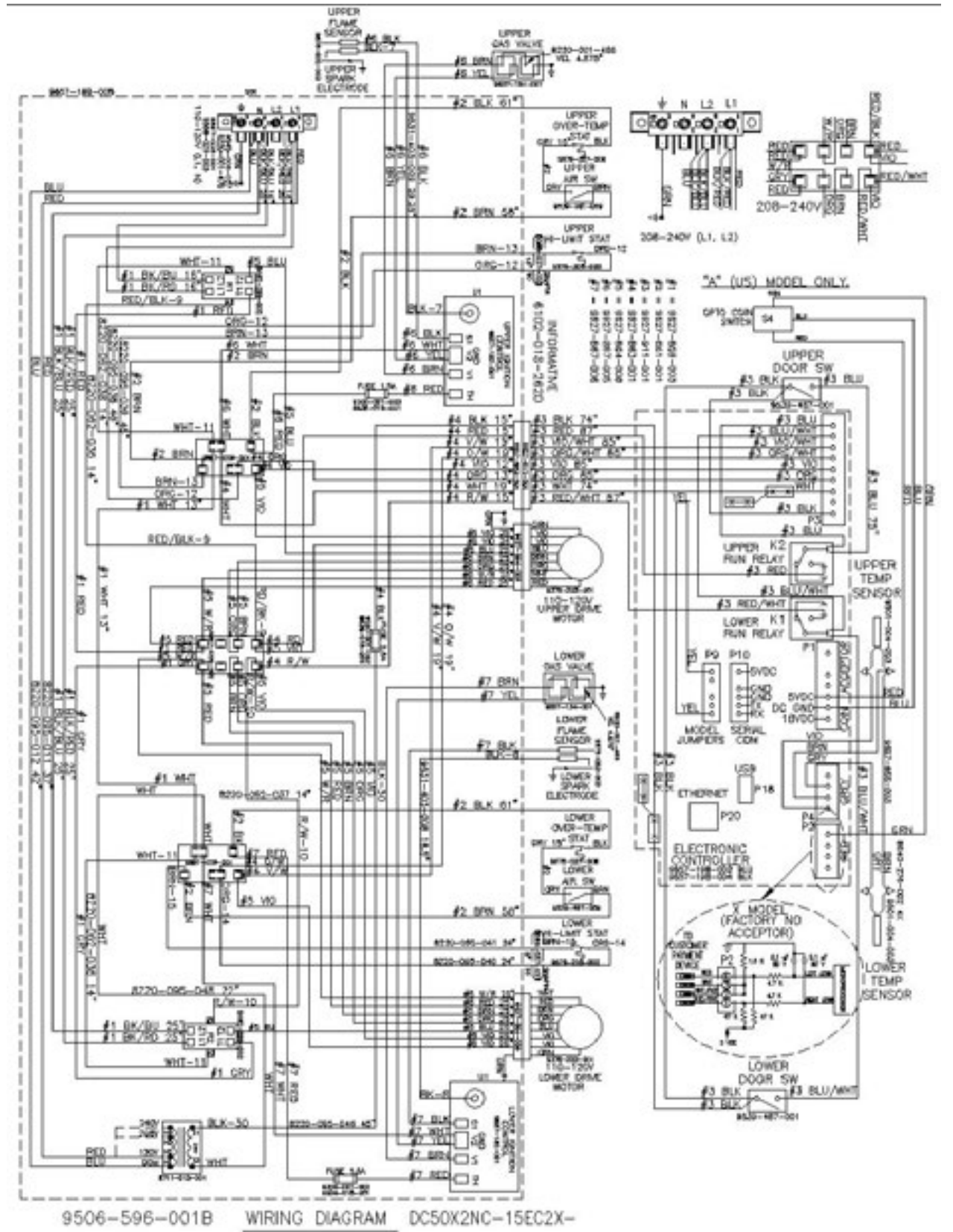

**Instructions - Convert a Dual Voltage Stack Dryer from 120V to 208-240V
(No Neutral Required)**

1. Remove incoming power from the dryer. Use a known working voltmeter to check power.
2. Remove the cover of the control box assembly from the dryer using a 5/16" wrench.
3. Move the black/blue wire AND the blue wire from the N position of the main power terminal block to the L2 position of the main power terminal block in the upper control box assembly. See figure below.
4. Move the white/red wire of the upper motor harness to an upper inner left terminal in the middle terminal block in the lower control box assembly. See figure below.
5. Move the orange wire of the upper motor harness to an upper inner left terminal in the middle terminal block in the lower control box assembly. See figure below.
6. Move the white/red wire of the lower motor harness to a lower inner left terminal in the middle terminal block in the lower control box assembly. See figure below.
7. Move the orange wire of the lower motor harness to a lower inner left terminal in the middle terminal block in the lower control box assembly. See figure below.

Conversion instructions continued on next page.

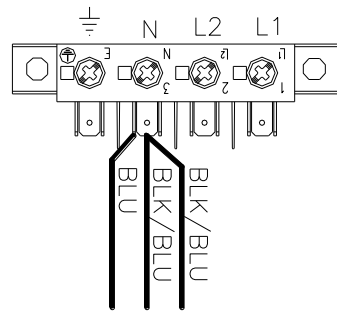

110-120V (L1, N)

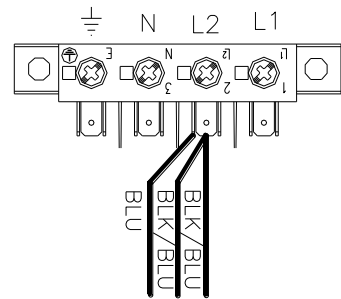

208-240V (L1, L2)

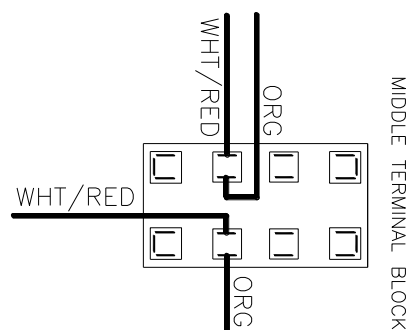
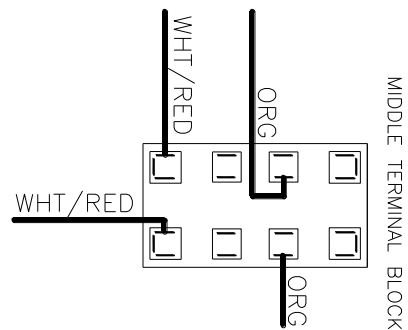

8. Move the red wire from the 120V tap on the transformer found in the bottom of control box to the required voltage tap based on actual supply voltage measurement. See figure below.

CONTROL TRANSFORMER CONNECTIONS
AS VIEWED FROM SIDE OF TRANSFORMER

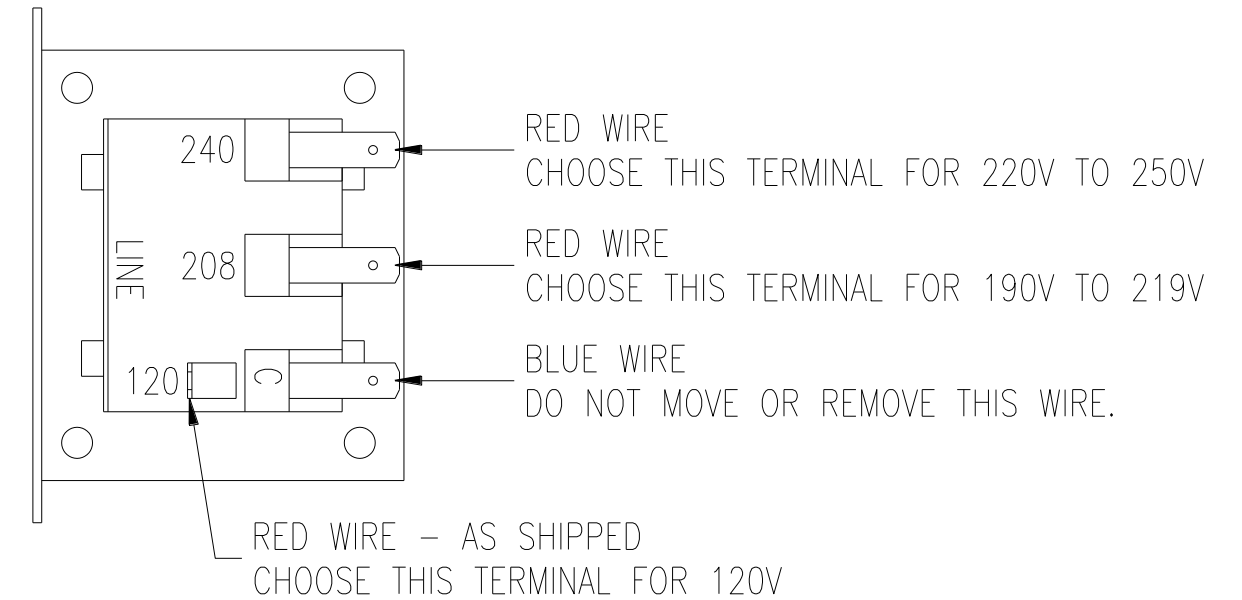

9. Reconnect power to the dryer and test to ensure proper operation; one line voltage to L1, one line voltage to L2 and the earth ground to E.
10. Reinstall the cover of the control box assembly on the dryer using a 5/16" wrench.

Notes

Lined area for notes.

Section 10:

50 hZ
Models

Notes

50 Hz Specifications

Dry Weight Capacity:	22.7kg @ 2 each - 45.4kg total
Basket Depth:	83.8 cm
Basket Diameter:	82.6 cm
Basket Volume:	447.4 liters
Door Opening:	65.1 cm
Overall Height (with legs):	201.3 cm
Cabinet Width:	87.6 cm
Overall Depth:	139 cm
Door Height (floor to bottom of door):	116.8 cm
Cylinder Rotation Direction:	CCW
Speed:	45rpm
Natural Gas Supply (water column):	5" - 10" wc
Natural Gas at Burner Manifold:	3.5" wc
LP Supply:	11.5" - 14" wc
LP Burner:	11" wc
Gas Inlet Line Size:	12.7 mm
Motor Size:	.56 kw

Electrical

Voltage:	220-240v/ 50hz/ 1 phase
Running Amps:	12.0
Amp Circuit Protection:	20
Wire Size:	3.5 mm
Electrical Service:	2 wire + ground

Weights

Shipping:	418.2 kg
Net Weight:	395.1 kg

Clearance behind machine for service minimums:	45.7 cm
--	---------

50HZ Wiring Schematic Dryer Idle - No Coins Added

Top Dryer Used For This Example

230 VAC 50 HZ is supplied to the Main Power Terminal Block and passes through a In-line Noise Filter and comes out on BLK/RED and BLK/BLU wire. 230 VAC now passes to a Multitap Control Step Down Transformer and also passes to the Motor Control Relay (R1&R2). When there is power to the dryer the Computer Board will be powered and the display lighted from the 24 VAC secondary side of Control Step Down Transformer. 24 VAC from here is also on one side of the door switch on a black wire. Closing the loading door allows 24 VAC to pass on to the Computer Board on two blue wires. One blue wire makes 24 VAC available to one side of the Motor Run Relay on Computer Board. The other blue wire provides a 24 VAC signal to the Computer Board telling it that the door is closed and door light on the computer board should be illuminated.

Coins Added - Motor Starting and Running

Top Dryer Used For This Example

As each coin is added the Coin Switch closes and completes a circuit to the Computer Board. The Computer Board counts these signals and registers them against time. The time will display once the Start Button for Upper or Lower is pushed. When the Start Button is pushed again the Computer Board Motor Run Relay closes on the computer. With this Relay closed, 24 VAC is supplied to the Motor Control Relay (R1) on the red wire and also a violet wire going down to motor. The motor LED on the computer board should be illuminated anytime the computer calls for the motor to operate. With (R1) engaged and 230 VAC at motor the Motor Start Switch in motor is drawn in to the start position. In this position the incoming power 230 VAC is supplied directly to the main run winding and through the Start Capacitor to the Auxiliary Winding (start winding). As the Motor comes up to speed, the centrifical switch inside motor opens the circuit to the Start Winding and closes the circuit to allow 24 VAC to pass to the Gas Relay on the Computer Board on the other violet wire. The heat circuit in the dryer can not operate if the motor is not running. The gas LED on the computer board will be illuminated when Computer Board calls for the heat after Motor Centrifical Switch has closed.

Heat Circuit

Top Dryer Used For This Example

With the Drive Motor running and 24 VAC provided to the Computer Board Gas Relay, it will close if Computer Board senses programmed temperature is needed. The violet wire changes to an orange wire out of the Computer Board Gas Relay. When this relay closes it provides 24 VAC to the High Limit Thermostat. The High Limit Thermostat is normally closed. (It will open, turning off the heat circuit, if the dryer can't move enough air from problems such as an exhaust restriction or other problems.) 24 VAC now goes through to the normally open Air Switch (Sail Switch) on the brown wire. This switch is closed only if the dryer is running and has the correct air flow. With the dryer running and the Air Switch closed, 24 VAC is supplied to the normally closed upper manual reset Overtemp Thermostat on the gray wire and changes to the black wire out of switch and then changes to red wire and goes to the 1.5 amp in-line fuse that protects the Upper Ignition Controller (GREY BOX). With 24 VAC now supplied to the Upper Ignition Controller (GREY BOX) it will then send high voltage to the Spark Ignition Electrode via the High Voltage Lead Wire (this lead looks like an automotive spark plug wire). The Ignition Control Module (GREY BOX) simultaneously sends 24VAC to the Gas Valve Coil which open the Gas Valve and allows gas to pass through to the main burner. When ignition occurs the high voltage sparking stops and if Ignition Control Module (GREY BOX) gets a flame sense signal it will allow gas valve coil to remain energized and continue burner operation. If ignition does not occur, the Ignition Control Module (GREY BOX) will spark for 10 seconds before locking out.

Manual Reset Safety Shutoff Over-Temperature Thermostat

Top Dryer Used For This Example

This thermostat is manually reset by pushing in the red button. The Over Temperature Thermostat is a safety backup for the entire Heat Circuit and located in the recirculation chamber area on the side of the burner housing. If the dryer over heats this Over Temperature Thermostat it opens the line to turn off the heat but leaves the Computer Board lighted and the drive motor powered and turning so the basket will cool down.

Cool Down

Top Dryer Used For This Example

At the preprogrammed time (2 minutes factory setting--adjustable) the Computer Board will open the Gas Relay Contact. This allows the Drive Motor to continue to run but without heat. The gas light on the computer board should not be illuminated anytime the computer is in cool down. This Cool Down period allows the clothing (zippers, snaps, etc.) time to cool down to a temperature that is easily handled by customers.

End of Cycle

Top Dryer Used For This Example

At the end of the cool down, the Computer Board opens the Upper Run Relay, which removes power from the Motor Control Relay (R1) and also removes power to the Drive Motor. The motor light on the computer board should no longer be illuminated. The Drive Motor and tumbler stops and the Computer Board display now flashes until the dryer loading door is opened. Once the dryer loading door is opened to remove the clothing the display goes back to vend price.

DC50X2 -49 50 Hz Parts

Key	Part Number	Description	Quantity
*	9558-029-005	Strip, Terminal Marker	1
*	5192-299-002	Motor Relay, 30Amp, 24VAC.....	1
1	8711-008-002	Transformer	1
*	8507-230-003	Instructions, Transformer Connect	1
2	9857-182-001	Ignition Control.....	2
*	9627-867-001	Harness-Ignition Control, Upper	1
*	9627-867-002	Harness-Ignition Control, Lower	1
*	9631-403-008	Wire Assembly High Voltage Upper	1
3	9631-403-009	Wire Assembly High Voltage Lower	1
4	9376-325-001	Motor.....	2
*	9453-169-014	Pulley, Motor Drive.....	1
*	9627-864-005	Harness Motor Extension.....	2
*	9506-598-001	Wiring Label Schematic/Diagram.....	1
*	8514-233-002	Owner's Manual	1
*	9866-005-006	Lint Drawer Assembly Upper/Lower.....	2
*	9435-024-002	Overlay, Lint drawer, Blue.....	2

DC50X2 -59 50 Hz Parts

Key	Part Number	Description	Quantity
*	9558-029-004	Strip, Terminal Marker	1
*	9558-033-001	Strip, Terminal Marker (After Serial).....	1
*	5192-299-002	Motor Relay, 30Amp, 24VAC.....	1
1	8711-008-002	Transformer	1
1	8711-004-004	Tranformer (After Serial)	1
*	8507-427-001	Instructions, Transformer Connect	1
*	8507-516-001	Instructions, Transformer Connect (After Serial).....	1
2	9857-140-001	Ignition Control Fenwal	2
*	9627-867-001	Harness-Ignition Control, Upper	1
*	9627-867-002	Harness-Ignition Control, Lower	1
*	9631-403-008	Wire Assembly High Voltage Upper	1
3	9631-403-009	Wire Assembly High Voltage Lower	1
4	9376-325-001	Motor.....	2
*	9453-169-014	Pulley, Motor Drive.....	1
*	9627-864-005	Harness Motor Extension.....	2
*	9506-648-001	Wiring Label Schematic/Diagram.....	1
*	9506-965-001	Wiring Label Schematic/Diagram (After Serial)	1
*	8514-233-002	Owner's Manual	1
*	8514-310-001	Owner's Manual (After Serial)	1
*	9866-004-009	Lint Drawer Assembly Upper/Lower.....	2
*	9435-024-002	Overlay, Lint drawer, Blue.....	2
*	9183-030-002	Filter Line, EMI.....	1

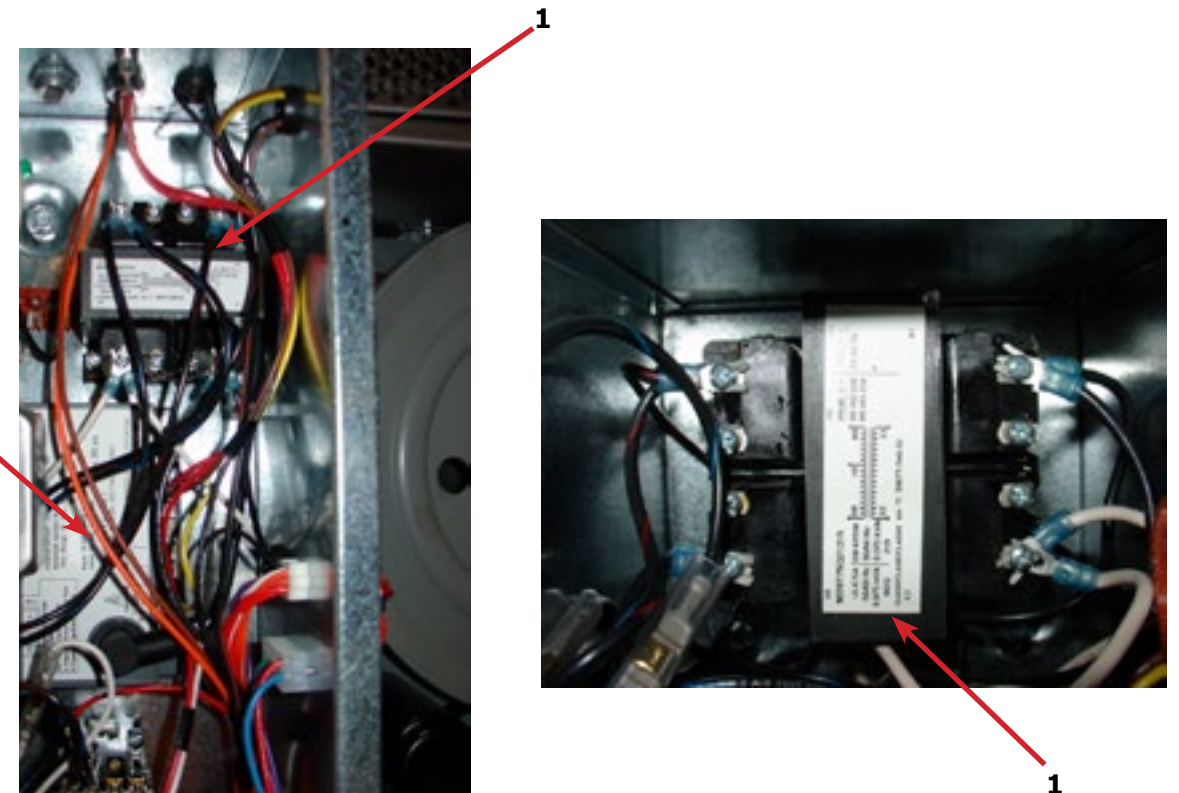
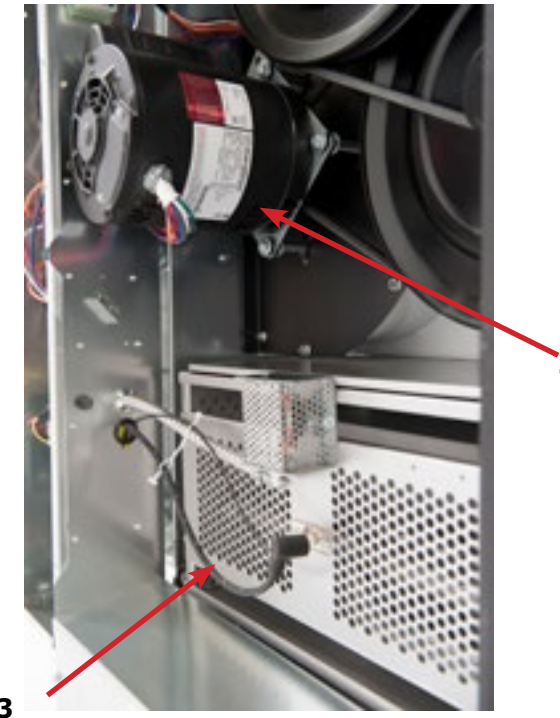

-24VAC Control Parts Group

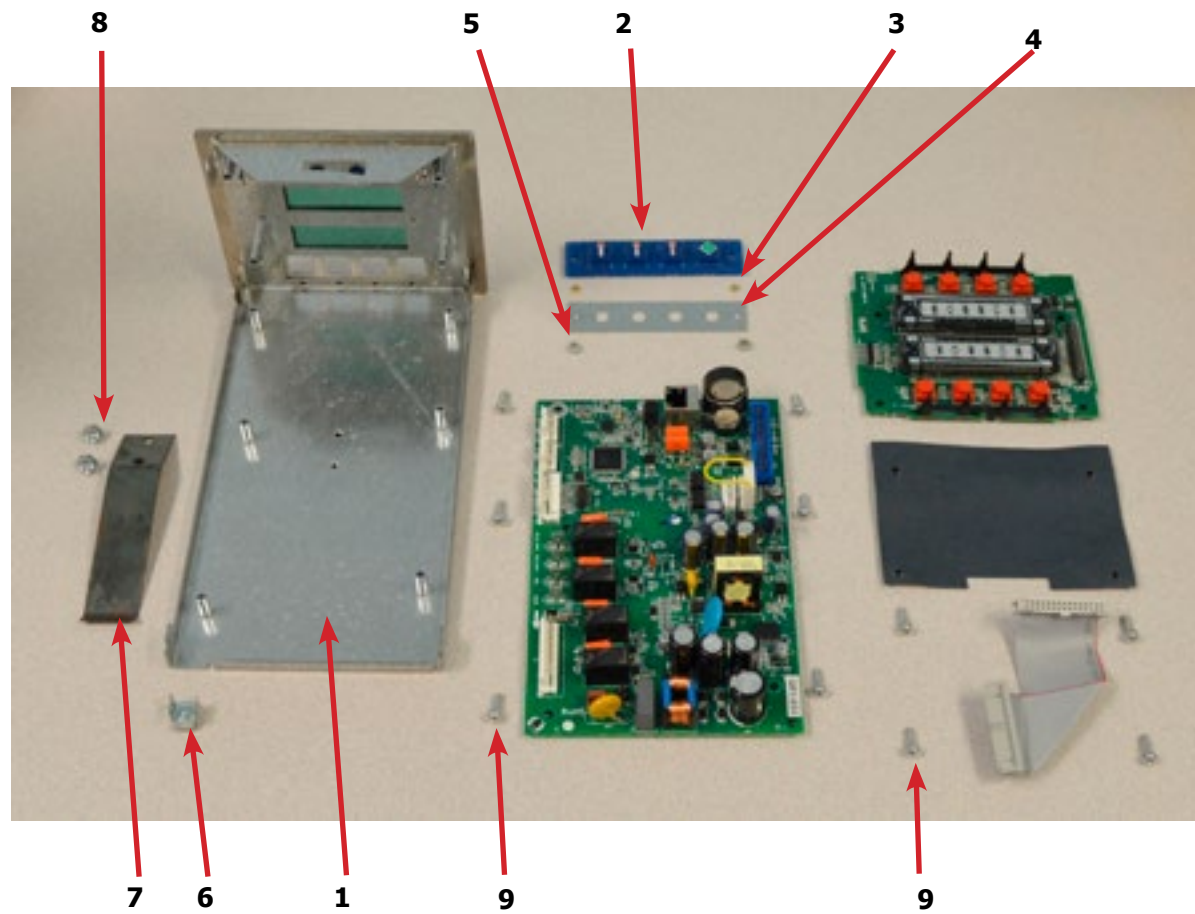

Key	Part Number	Description	Quantity
*	9857-198-002	Controls Assy, Electronic Mounted With Membrane Switch, BLU...	1
*	9857-198-004	Controls Assy, Electronic Mounted With Membrane Switch, BLK...	1
1	9826-008-001	Trough Assembly	1
2	9032-062-002	Button-Push, Control, Blue	2
2	9032-062-001	Button-Push, Control, Black.....	2
3	9538-166-011	Spacer-Metal, 4mm	4
4	9486-158-001	Retainer-Push Button	2
5	8640-424-002	Nut-Hex, Elastic stop, #4-40	4
6	8652-130-038	Terminal-Grounding clip	1
7	9534-365-001	Spring-Flat, Control	1
8	9545-008-001	Screw-Hex, #10B x 1/4	2
9	9545-044-010	Screw-Hex, #10B x 1/4	10
9	8641-582-005	Washer-External tooth, #6	10
10	9435-038-001	Overlay-Control, Coin, Black	1
10	9435-038-002	Overlay-Control, Coin, Blue	1

Note: Jumpers required if using 1.5 Control on Older Machines (P9 Connection)

*	8220-155-001	Wire Assy, Jumper, 30Lb Stack Coin	1
*	8220-155-002	Wire Assy, Jumper, 30Lb Stack Coin	1

