



DEXTER[®]
LAUNDRY

**USE THE BLUE TABS LOCATED ON THE
RIGHT AND LEFT SIDES OF THE FOLLOWING
DOCUMENT TO ADVANCE TO EACH SECTION.**

Kits, Assemblies, & Common Parts

Description	T-30	T-50	T-80
Kit - T80 Bottom exhaust			9732-348-001
Kit - 9873-008-001 w/ bearings & tolerance ring	9732-329-001	9732-329-001	9732-329-001
LP to Natural Conversion Kit for White Rodgers	9732-102-018	9732-102-017	9732-102-023
Kit, Optional Replacement for Round Switch 9539-492-001	9732-351-001	9732-351-001	9732-351-001
Temperature Probe	9501-004-002	9501-004-002	9501-004-002
Kit-30/50/80 OPL, PCB-Controler	9732-249-001	9732-249-001	9732-249-001
Ignition Control Box	9857-182-001	9857-182-001	9857-182-001
Electrode Assembly, Ignition	9875-002-003	9875-002-003	9875-002-003
Thermostat, Hi-Limit	9576-203-002	9576-203-002	9576-203-002
Thermostat, Overtemp	9576-207-006	9576-207-006	9576-207-006
Fuse, .600MA/250V	8636-024-001	8636-024-001	8636-024-001
Motor Run Relay	5192-299-002	5192-299-002	5192-299-002
Transformer, Control	8711-007-002	8711-007-002	8711-007-002
Screen Assy, Lint	9822-026-002	9822-026-001	9822-031-002
Air Flow Switch	9801-095-001	9801-098-001	9801-098-001
Switch-Door (Round)	9539-492-001	9539-492-001	9539-492-001
Switch-Door (Square)	9539-501-001	9539-501-001	9539-501-001
Motor Drive Belt	9040-076-003	9040-076-006	9040-076-011
Tumbler Drive Belt	9040-073-009	9040-073-011	9040-073-012
Tension Arm Complete	9861-022-001	9861-022-002	9861-024-004
Spider/Trunnion	9568-015-001	9568-013-001	9873-008-001
Door Handle	9244-082-001	9244-082-001	9244-082-001
Run Capacitor		5191-108-001	5191-108-001
Start Capacitor		5191-109-001	5191-109-001
Cleanout Duct Assembly 8"	9973-034-001	9973-034-001	3373-034-001



Section 5: Dryer Parts Data

DN0030NC-10
DN0050NC-10
DN0080NC-10

Dryer Cabinet Group

Key	Description	T-30	T-50	T80	QTY
1	Loading Door Complete SS/Brushed SS/Blk	9960-306-001	9960-305-001	9960-305-001	1
1	Loading Door Complete Wht/Brushed SS/Blk	9960-306-003	9960-305-003	9960-305-003	1
2	Door Assy, Loading (Ring only) Brushed SS	9960-255-008	9960-284-002	9960-284-002	1
2	Door Assy, Loading (Ring only) Black (after serial D1.22290.005)	9960-319-007	9960-320-004	9960-320-004	1
3	Plate Assy, Hinge (SS)	9982-374-001	9982-368-001	9982-368-001	1
3	Plate Assy, Hinge (Wht)	9982-374-003	9982-368-003	9982-368-003	1
*	Cover-Hinge Back, Black	9074-341-002	9074-340-002	9074-340-002	1
*	Screw-10Bx3/8, Black	9545-008-010	9545-008-010	9545-008-010	2
*	Screw Hinge to Door	9545-012-015	9545-012-015	9545-012-015	4
*	Nut, Hinge to Door	8640-413-002	8640-413-002	8640-413-002	4
4	Glass, Door	9212-002-003	9212-002-004	9212-002-004	1
5	Gasket, Door Glass (Black)	9206-413-001	9206-413-002	9206-413-002	1
*	Support Door Glass	9548-117-000	9548-117-000	9548-117-000	2
6	Gasket, Door Outer Rim (Black)	9206-420-003	9206-420-005	9206-420-005	1
7	Handle, Loading Door	9244-082-001	9244-082-001	9244-082-001	1
*	Screw, Handle	9545-018-017	9545-018-017	9545-018-017	2
8	Stud Door Catch	9531-033-002	9531-033-002	9531-033-002	1
9	Nut-Hex, #10-32	8640-413-001	8640-413-001	8640-413-001	1
10	Nut, Acorn	8640-413-003	8640-413-003	8640-413-003	1
*	Catch, Loading Door	9086-015-002	9086-015-002	9086-015-002	2
*	Rivit	8638-190-009	8638-190-009	8638-190-009	4
11	Strap, Hinge (Black)	9966-018-002	9966-014-002	9966-014-002	1
*	Plate Assy-Backup, Hinge	9982-386-001	9982-356-001	9452-790-001	2
*	Plate Assy-Backup, Hinge			9982-369-001	1
*	Reinforcement-Front panel			9817-003-001	1
12	Screw-Phillips, 10-32x1/2 Chrome	9545-012-003		9545-012-003	8
*	Screw-Phillips-Counter sink, 10-32x1/2 Chrome	NA		9545-012-028	4
13	Screw-Special, Hinge to Door	9545-052-001	9545-052-001	9545-052-001	1
*	Nut-Allen, 1/4-20	8640-439-001	8640-439-001	8640-439-001	1
14	Washer-Fiber/Plastic	8641-436-003	8641-436-003	8641-436-003	1
15	Front Panel Assy (SS) Round Switch	9454-918-001	9454-866-001	9454-868-001	1
15	Front Panel Assy (SS) Square Switch	9444-002-001	9444-004-001	9444-006-001	1
15	Front Panel Assy (Wht) Round Switch	9454-918-003	9454-866-003	9454-868-003	1
15	Front Panel Assy (Wht) Square Switch	9444-002-003	9444-004-003	9444-006-003	1
16	Screw-Phillips, 10Bx1 3/4	9545-008-014	9545-008-014	9545-008-014	4
17	Washer-Finish	8641-585-001	8641-585-001	8641-585-001	4
*	Nut-Spring (Before Serial)	8640-399-001	8640-399-001	8640-399-001	4
*	Nut, Expansion (After Serial D1.21187.042)	8640-442-001			4
*	Nut, Expansion (After Serial D1.21162.038)		8640-442-001		4
*	Nut, Expansion (After D1.21177.005)			8640-442-001	4
*	Insulation-Front Panel, Top Half	9277-063-001	9277-057-001	9277-058-001	1
*	Insulation-Front Panel, Bottom Half	9277-063-002	9277-057-001	9278-058-002	1
18	Label-Warning	8502-753-001	8502-753-001	8502-753-001	1
19	Plug-Front Panel	9456-050-001	9456-050-001	9456-050-001	1
*	Switch-Door (Round)	9539-492-001	9539-492-001	9539-492-001	1
*	Switch-Door (Square)	9539-501-001	9539-501-001	9539-501-001	1

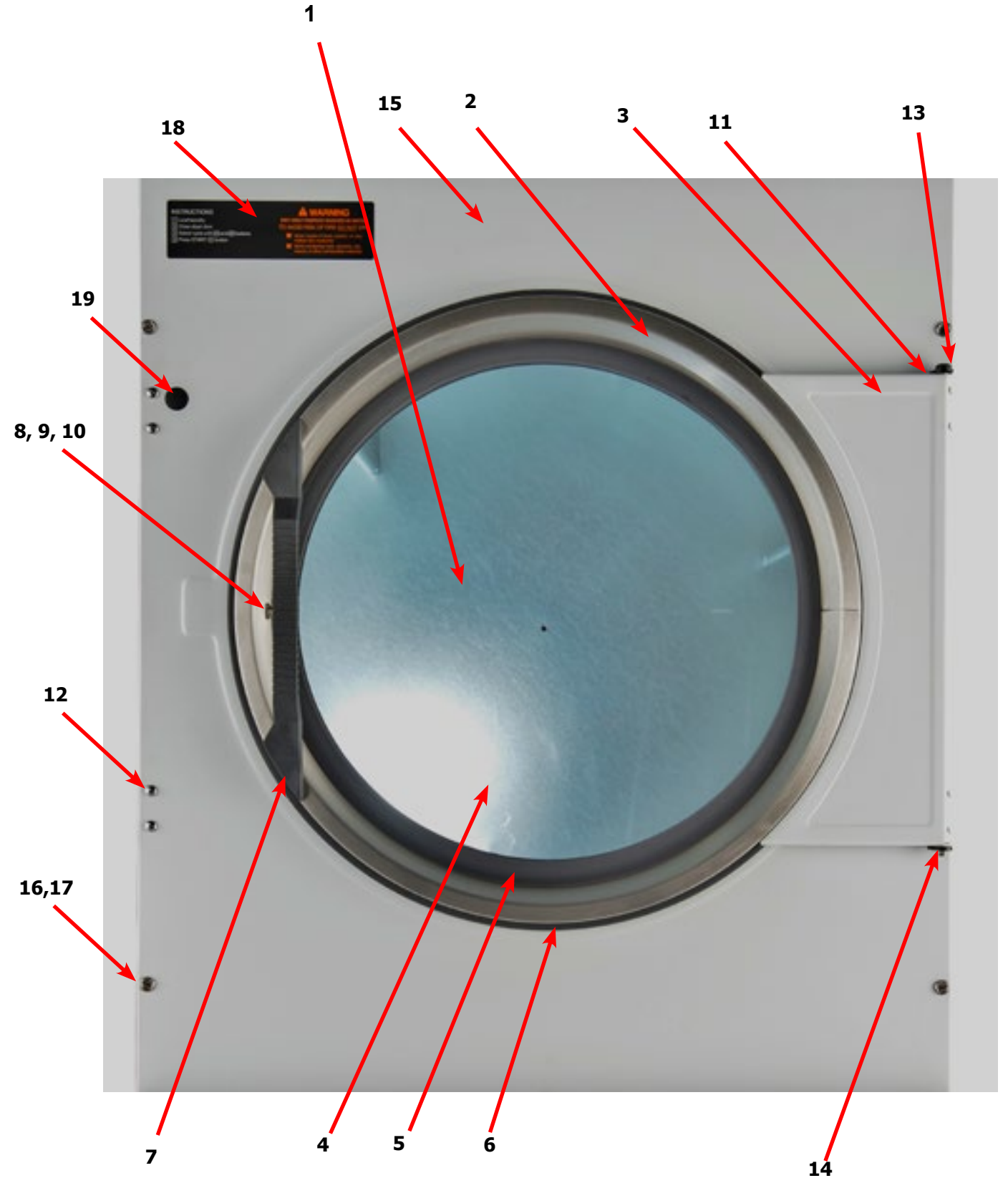

Key	Description	T-30	T-50	T80	QTY
*	Wire-Assy, Blk	8220-063-026	8220-063-026	8220-063-026	1
*	Wire-Assy-Blu	8220-063-009	8220-063-009	8220-063-009	1
*	Cover-Door Switch			9074-351-001	1
*	Nut-#10-32unf, 2B			8641-413-002	2
*	Cabinet Touch Up Paint (White)	9472-001-013	9472-001-013	9472-001-013	1

Dryer Cabinet Group Continued

Key	Description	T-30	T-50	T80	QTY
1	Nameplate - Dexter Dryer Black	9412-196-001	9412-196-001	9412-196-001	1
2	Door Assy-Upper, OPL (SS)	9960-288-001	9960-290-001	9960-292-001	1
2	Door Assy-Upper, OPL (Wht)	9960-288-003	9960-290-003	9960-292-003	1
*	Bracket-Hinge	9029-224-001	9029-224-001	9029-224-001	2
*	Rivit- 3/16, Hinge to Door	9491-009-001	9491-009-001	9491-009-001	2
*	Rivit- 3/16, Hinge to Cabinet	9491-009-001	9491-009-001	9491-009-001	AR
3	Trim-Upper Service Door, Black	9578-098-002	9578-094-002	9578-096-002	1
4	Screw-Phillips, 10Bx3/8, Black	9545-008-010	9545-008-010	9545-008-010	4
5	Screw-Phillips, 10Bx1 3/4	9545-008-014	9545-008-014	9545-008-014	2
6	Washer-Finish	8641-585-001	8641-585-001	8641-585-001	2
*	Nut-Spring	8640-399-001	8640-399-001	8640-399-001	2
7	Membrane Switch	9801-104-001	9801-104-001	9801-104-001	1
8	Kit-30/50/80 OPL, PCB-Controller	9732-249-001	9732-249-001	9732-249-001	1
*	Spacer-#6 x 1/2	9538-157-016	9538-157-015	9538-157-015	4
9	Nut- #6-32	8640-411-003	8640-411-003	8640-411-003	4
10	Wire Assy-GRN, 24"	8220-137-001	8220-137-001	8220-137-001	1
11	Fuse, .600MA/250V	8636-024-001	8636-024-001	8636-024-001	1
12	Support-Upper Service Door	9548-288-001	9548-288-001	9548-288-001	1
13	Clamp-Tube	9079-121-002	9079-121-002	9079-121-002	2
14	Nut, #6-32	8640-411-003	8640-411-003	8640-411-003	2
15	Clamp-Cable, 1/2"	8654-125-006	8654-125-006	8654-125-006	1
16	Nut, #6-32	8640-411-003	8640-411-003	8640-411-003	1
17	Insulation	9277-041-016	9277-041-016	9277-041-016	1
*	Harness-Control	9627-770-001	9627-770-001	9627-770-001	1
*	Harness-Temp Probe	9627-679-002	9627-679-002	9627-679-002	1

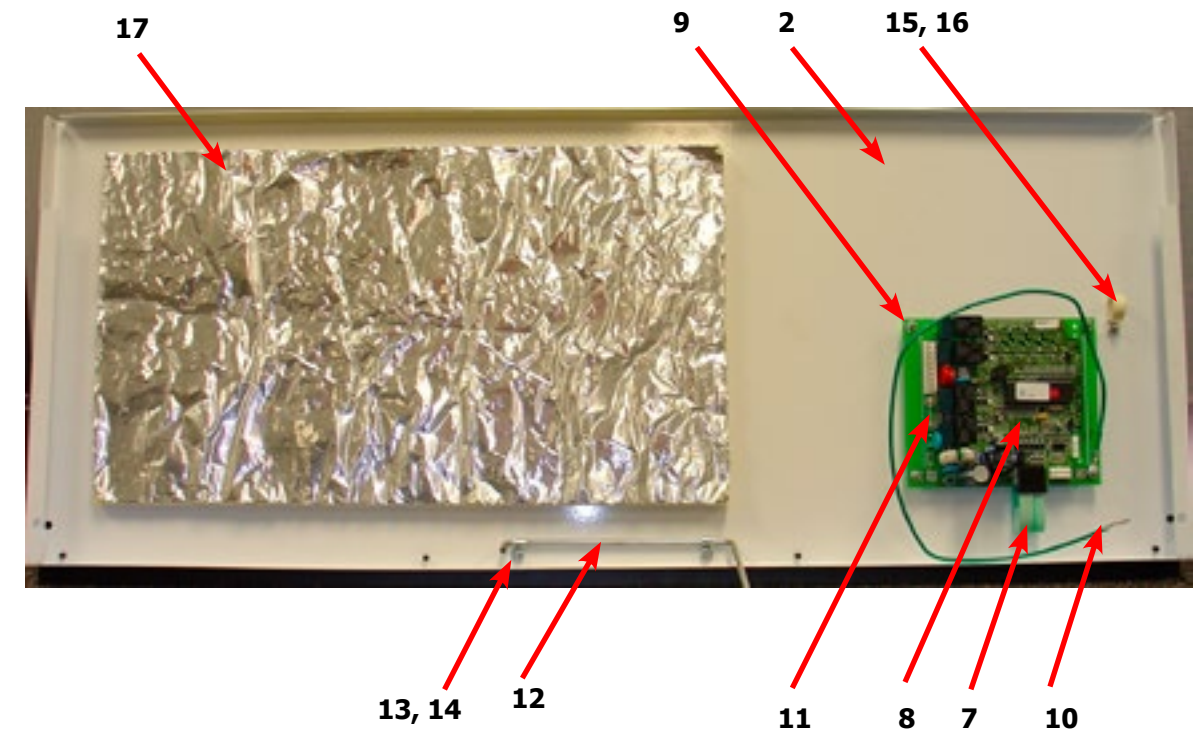
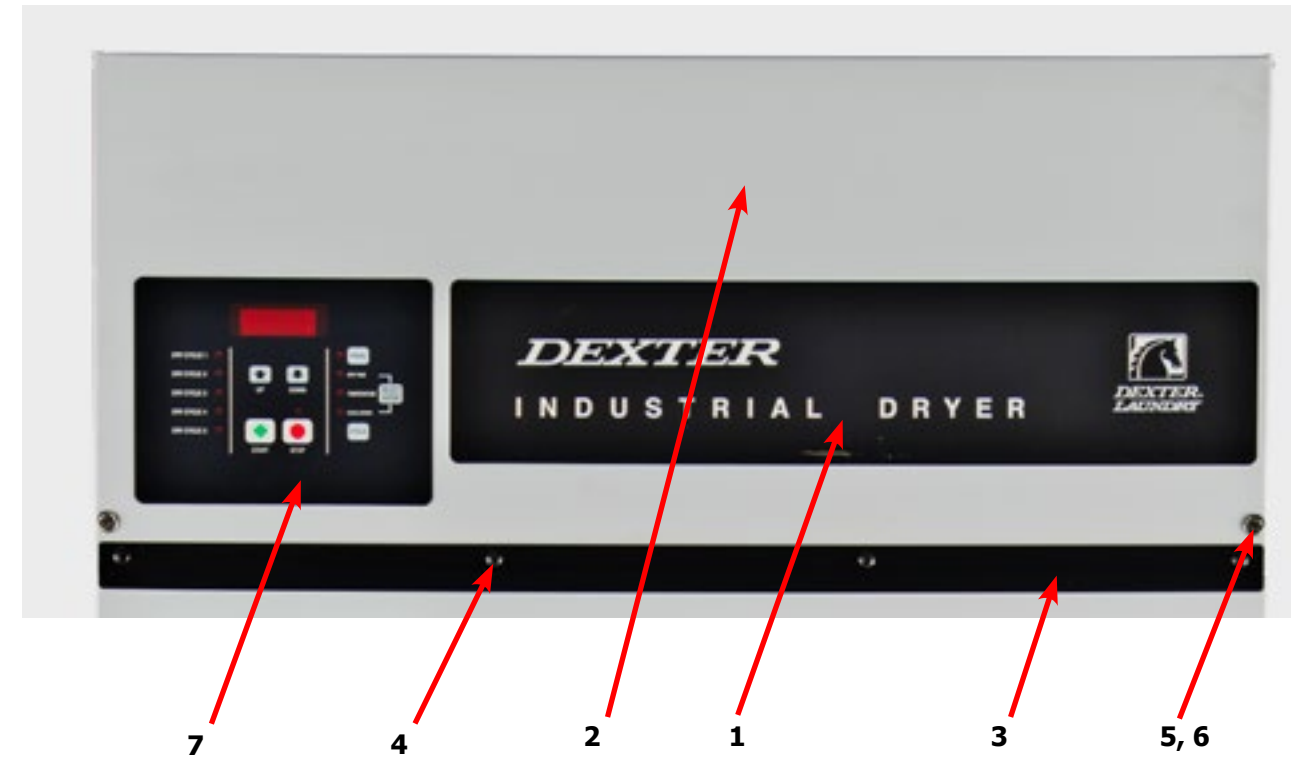

Dryer Cabinet Group Continued

Key	Description	T-30	T-50	T80	QTY
1	Door-Lower Service, OPL, SS	9108-131-001	9108-123-001	9108-127-001	1
1	Door-Lower Service, OPL, Wht	9108-131-003	9108-123-003	9108-127-003	1
2	Handle-Door, Lower Service, Black	9244-089-002	9244-087-002	9244-088-002	1
3	Screw-Phillips, 10Bx3/8, Black	9545-008-010	9545-008-010	9545-008-010	5
4	Handle-Door, Lower Service OPL	9244-084-002	9244-084-002	9244-084-002	1
5	Trim-Lower Kick, Black	9578-099-002	9578-095-002	9578-097-002	1
6	Screw-Phillips, 10Bx3/8, Black	9545-008-010	9545-008-010	9545-008-010	4
7	Screen Assy, Lint	9822-026-002	9822-026-001	9822-031-002	1
8	Switch-Door (Round)	9539-492-001	9539-492-001	9539-492-001	1
*	Switch-Door (Square)	9539-501-001	9539-501-001	9539-501-001	1
*	Kit, Optional Replacement for Round Switch 9539-492-001	9732-351-001	9732-351-001	9732-351-001	1
9	Hinge-Door, Lower	9243-081-001	9243-082-001	9243-082-001	1
10	Screw-5/16, 10ABx3/8	9545-008-024	9545-008-024	9545-008-024	5
11	Bracket-Door Switch	9029-226-001	9029-226-001	9029-226-001	1
*	Rivit, 1/8 Low Profile	9491-009-004	9491-009-004	9491-009-004	2
12	Bracket-Chain	9029-233-001	9029-233-001	9029-233-001	2
*	Rivit, 1/8 Low Profile	9491-009-004	9491-009-004	9491-009-004	8
13	Hook, "S" Type	9248-022-002	9248-022-002	9248-022-002	4
14	Chain-Lower Service Door	9099-012-006	9099-012-006	9099-012-006	2
*	Leg, Leveling 1/2"	8544-006-001	8544-006-001	8544-006-001	4
*	Leveling Leg Wrench	8545-061-002	8545-061-002	8545-061-002	1

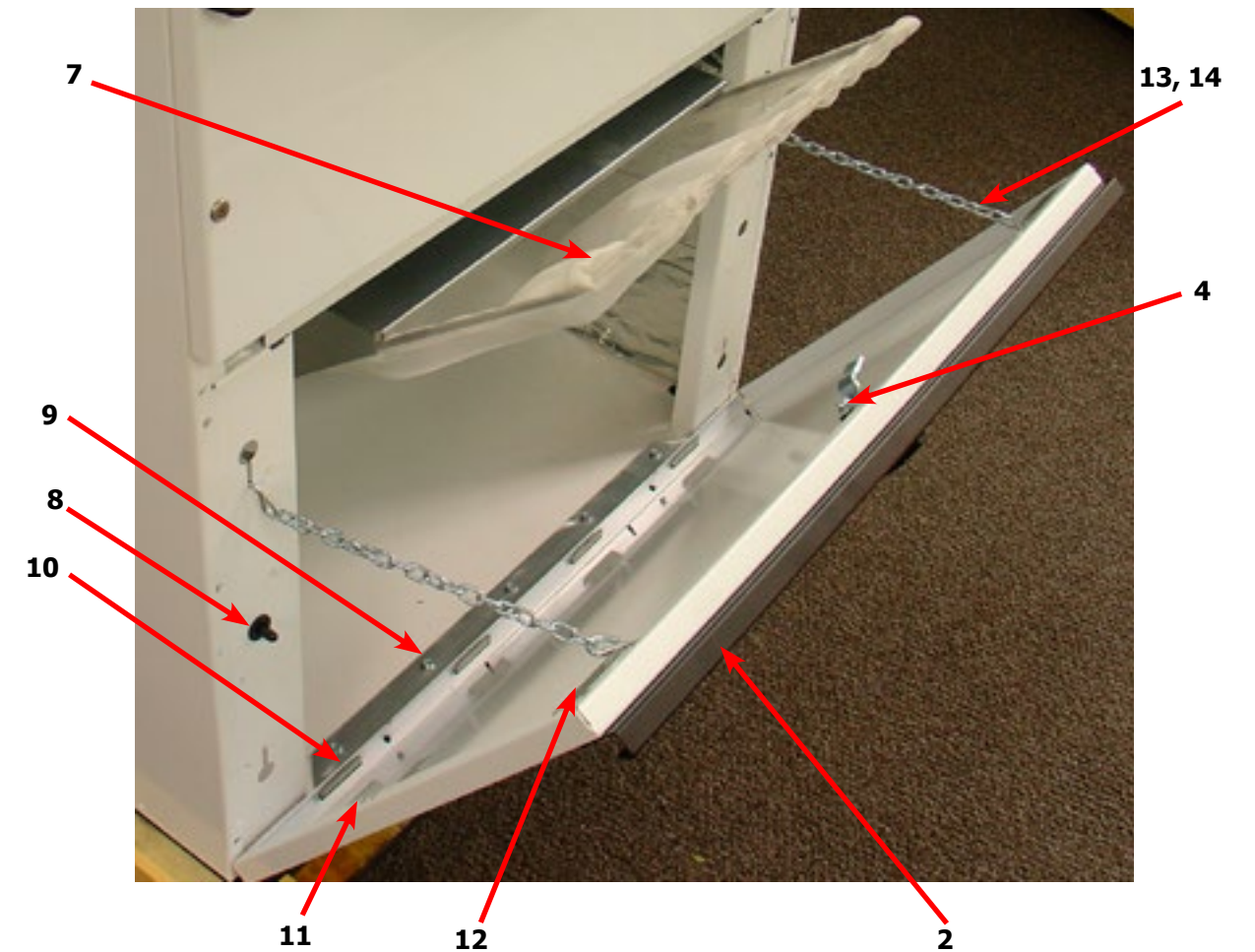
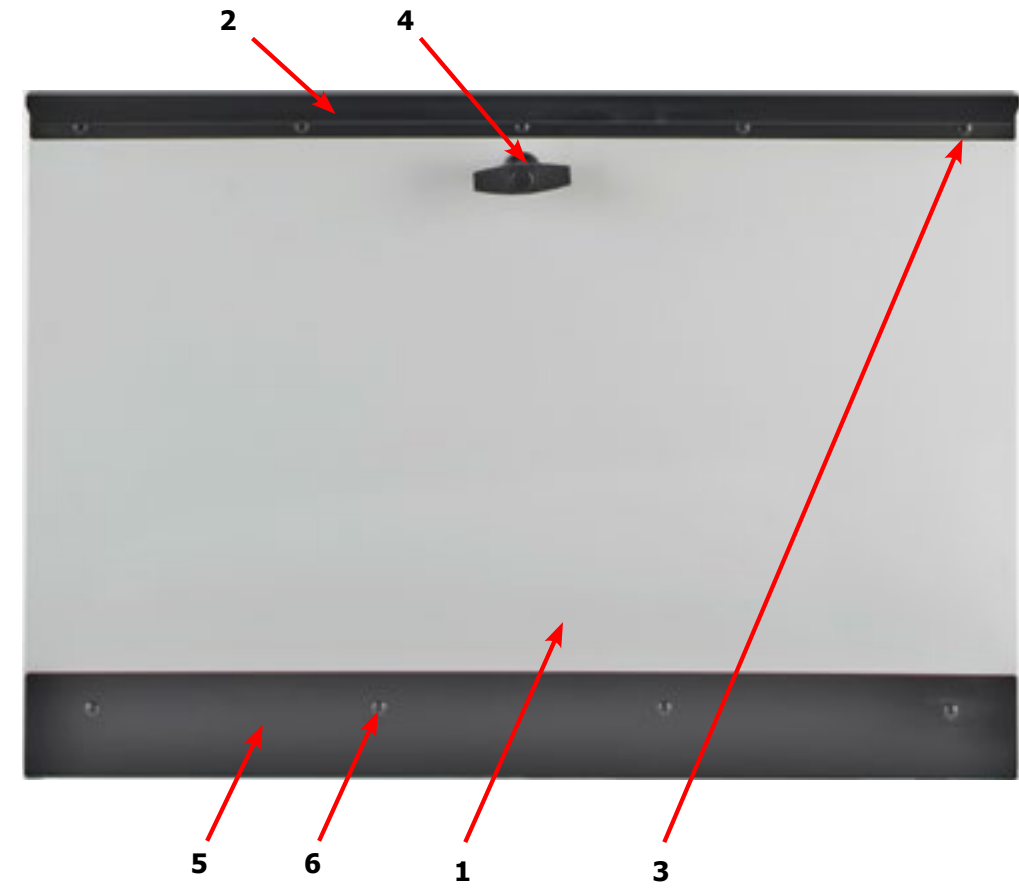

Dryer Cabinet Group Continued

Key	Description	T-30	T-50	T80	QTY
1	Insulation, Upper service Door	9277-041-006	9277-041-016	9277-041-016	1
2	Insulation, RH Burnner	9277-041-019	9277-041-023	9277-041-023	1
3	Insulation Tumbler Area, above Baffle	9277-041-020	9277-041-023		2
3	Insulation Tumbler Area, above Baffle		9277-041-023	9277-041-021	
4	Insulation Tumbler Area, below baffle	9277-041-020	9277-051-003		2
4	Insulation Tumbler Area, below baffle		9277-051-003	9277-041-004	2
4	Insulation Tumbler Area, below baffle			9277-041-004	6
5	Insulation Lint Compartment	9277-041-021	9277-041-024	9277-041-025	2
*	Screen Assy, Lint	9822-026-002	9822-026-001	9822-031-002	1
6	Switch-Door (Round)	9539-492-001	9539-492-001	9539-492-001	1
*	Switch-Door (Square)	9539-501-001	9539-501-001	9539-501-001	1
7	Hinge-Door, Lower	9243-081-001	9243-082-001	9243-082-001	1
8	Screw-5/16, 10ABx3/8	9545-008-024	9545-008-024	9545-008-024	AR
9	Lint Hood-Back	9240-038-001	9240-041-001	9240-044-001	1
10	Nut Wizlock, 8-32	8640-412-004	8640-412-004	8640-412-004	6
11	Lint hood, LH	9240-040-001	9240-043-001	9240-046-001	1
12	Lint hood, RH	9240-040-002	9240-043-002	9240-046-002	1
13	Lint hood, Top	9240-039-001	9240-042-001	9240-045-001	1
14	Screw, 5/16- 10ABx3/8	9545-008-024	9545-008-024	9545-008-024	14
15	Impeller, w/set screws	9278-043-001	9278-038-004	9278-037-003	1
16	Harness -Temp Probe	9627-679-002	9627-679-002	9627-679-002	1
17	Wire Nut, #71B	8640-276-005	8640-276-005	8640-276-005	2
18	Bracket, Temp Probe	9029-197-001	NA	NA	1
19	Screw-5/16, 10ABx3/8	9545-008-024	NA	NA	1
20	Temp Probe	9501-004-002	9501-004-002	9501-004-002	1
21	Screw-Phillips, 8Bx1/4	9545-045-005	9545-045-005	9545-045-005	1

30lb Temp Probe

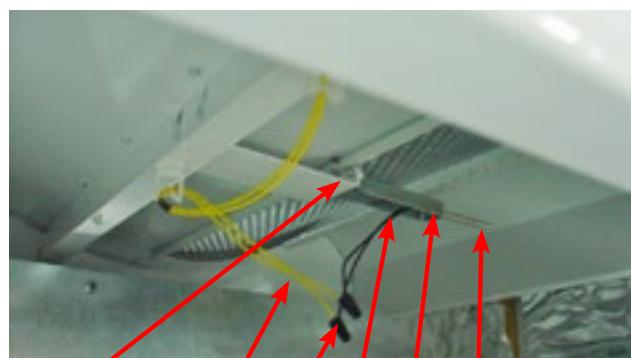

19 16 17 18 21 20

50Lb & 80Lb Temp Probe

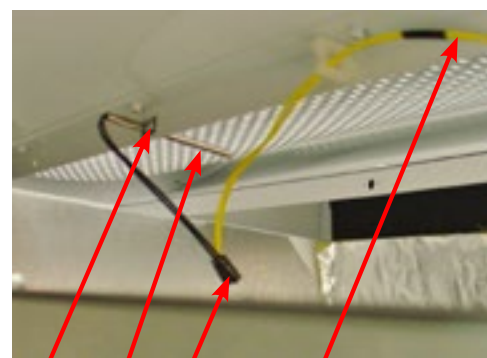

21 20 17 16

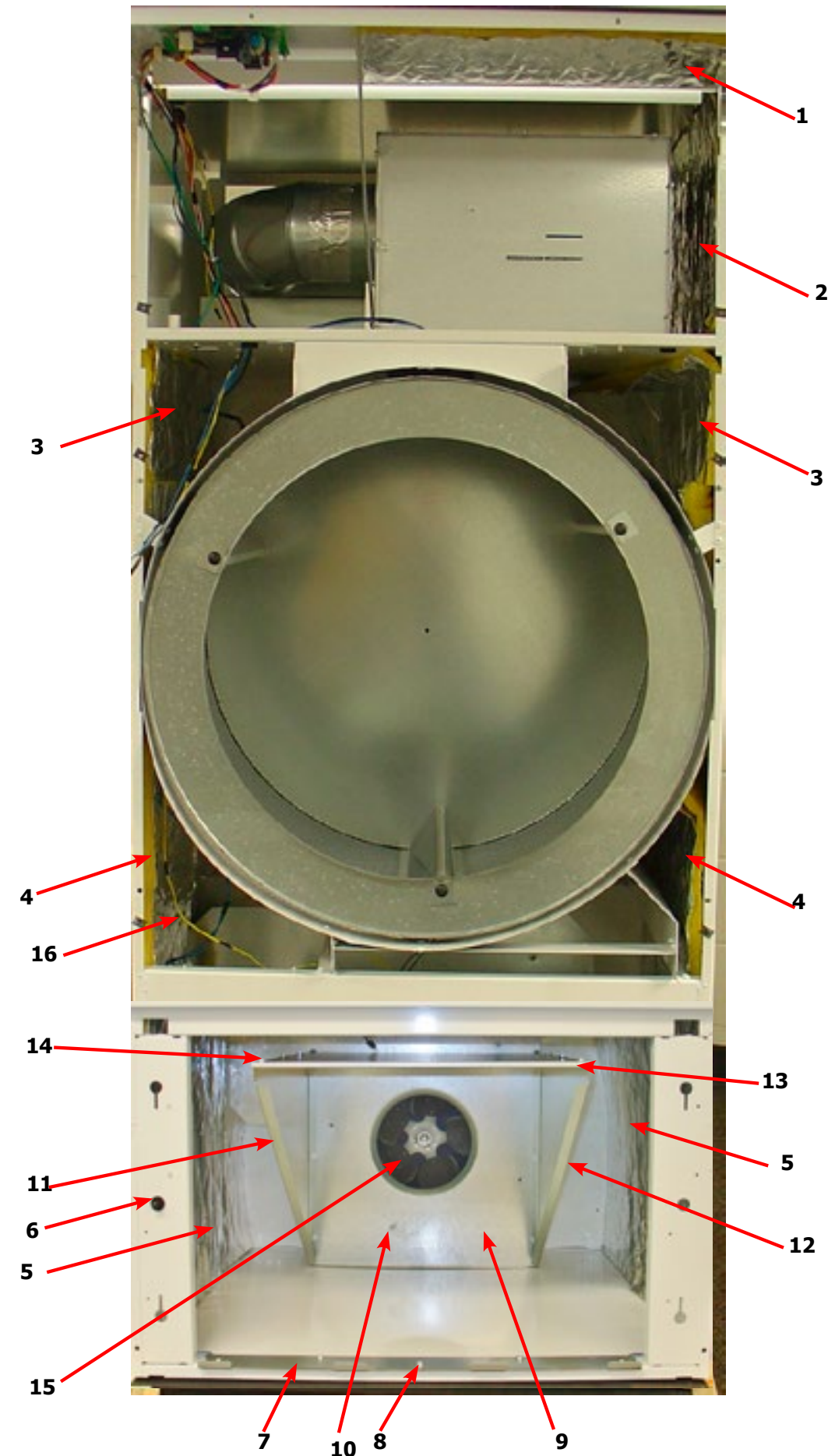

Dryer Modular Cabinet Group 30lb. (After Serial D1.23164.026)

Key	Description	T30	QTY
1	Cabinet Base Assembly	9945-166-001	1
*	Lower Back Panel Assembly	9989-730-002	1
2	Lower Cabinet RH Side Panel	9444-109-003	1
3	Lower Cabinet LH Side Panel	9444-109-004	1
4	Lower Cabinet Front Channel	9081-224-001	1
*	Upper Back Panel Assembly	9989-731-002	1
5	RH Middle Side Panel Assembly	9444-111-003	1
6	LH Middle Side Panel Assembly	9444-111-004	1
7	Cabinet Top	9577-070-001	1
8	RH Baffle	9049-131-001	1
9	LH Baffle	9049-132-001	1
*	Baffle Angled Bracket	9029-371-001	2
10	RH Upper Side Panel	9444-113-003	1
11	LH Upper Side Panel	9444-113-004	1
12	Upper Cross Brace	9046-107-001	1
*	10abx3/8 Screw	9545-008-024	25
*	3/16 Blind Rivet	9491-009-001	171
*	Wht 3/16 Blind Rivet	9491-009-005	48

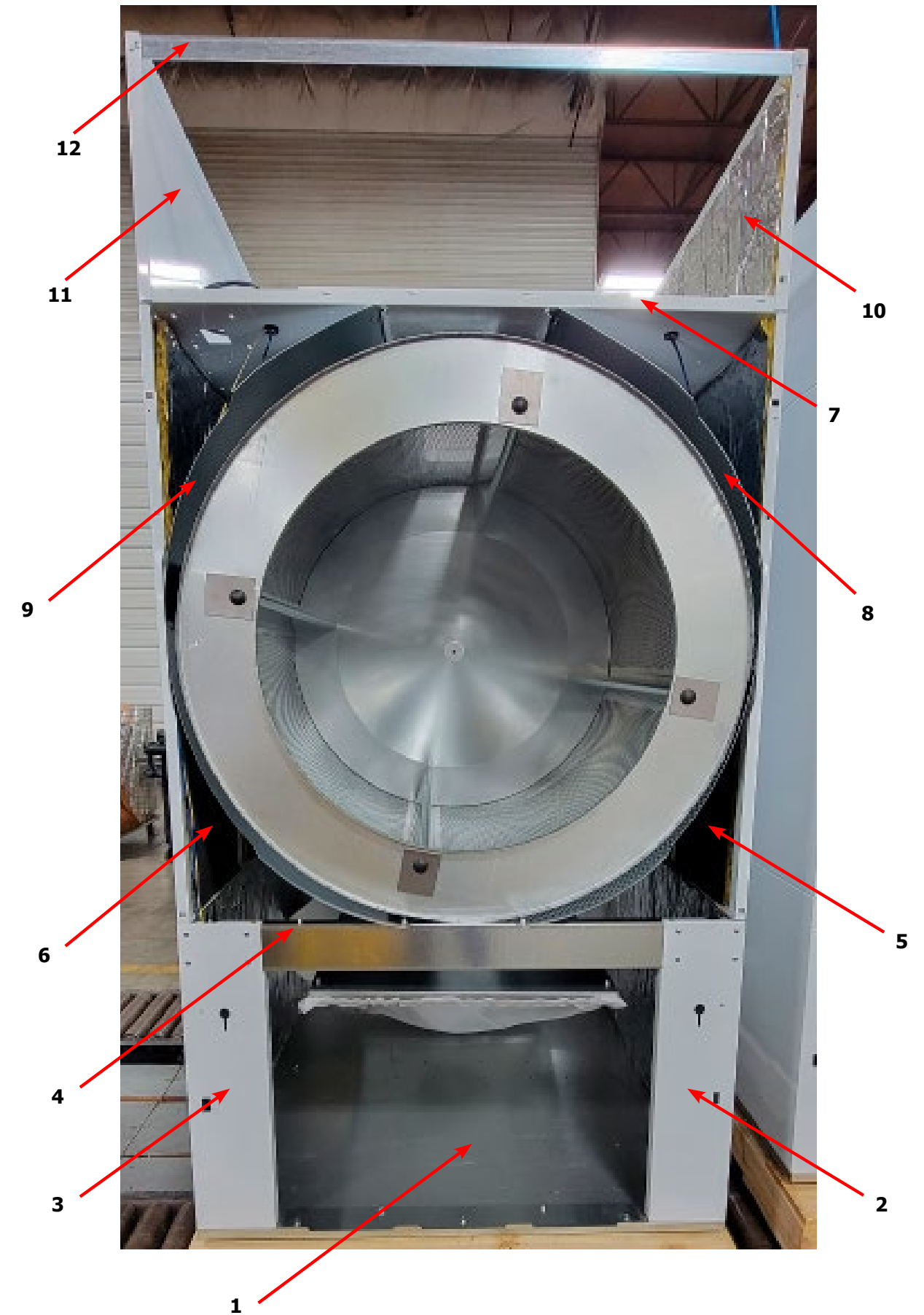

Dryer Modular Cabinet Group 50lb. (After Serial D1.23145.014)

Key	Description	T50	QTY
1	Cabinet Base Assembly	9945-165-001	1
*	Lower Back Panel Assembly	9989-726-002	1
2	Lower Cabinet RH Side Panel	9444-104-003	1
3	Lower Cabinet LH Side Panel	9444-104-004	1
4	Lower Cabinet Front Channel	9081-222-001	1
*	Upper Back Panel Assembly	9989-727-002	1
5	RH Middle Side Panel Assembly	9989-728-003	1
6	LH Middle Side Panel Assembly	9989-728-004	1
7	Cabinet Top Assembly	9961-164-001	1
8	RH Baffle	9049-130-001	1
9	LH Baffle	9049-130-002	1
*	Baffle Stiffener Angle	9003-386-001	2
10	RH Upper Side Panel	9444-108-003	1
11	LH Upper Side Panel	9444-108-004	1
12	Upper Cross Brace	9046-105-001	1
*	10abx3/8 Screw	9545-008-024	21
*	Large Head Pop Rivet	8638-190-028	4
*	3/16 Blind Rivet	9491-009-001	122
*	Wht 3/16 Blind Rivet	9491-009-005	54

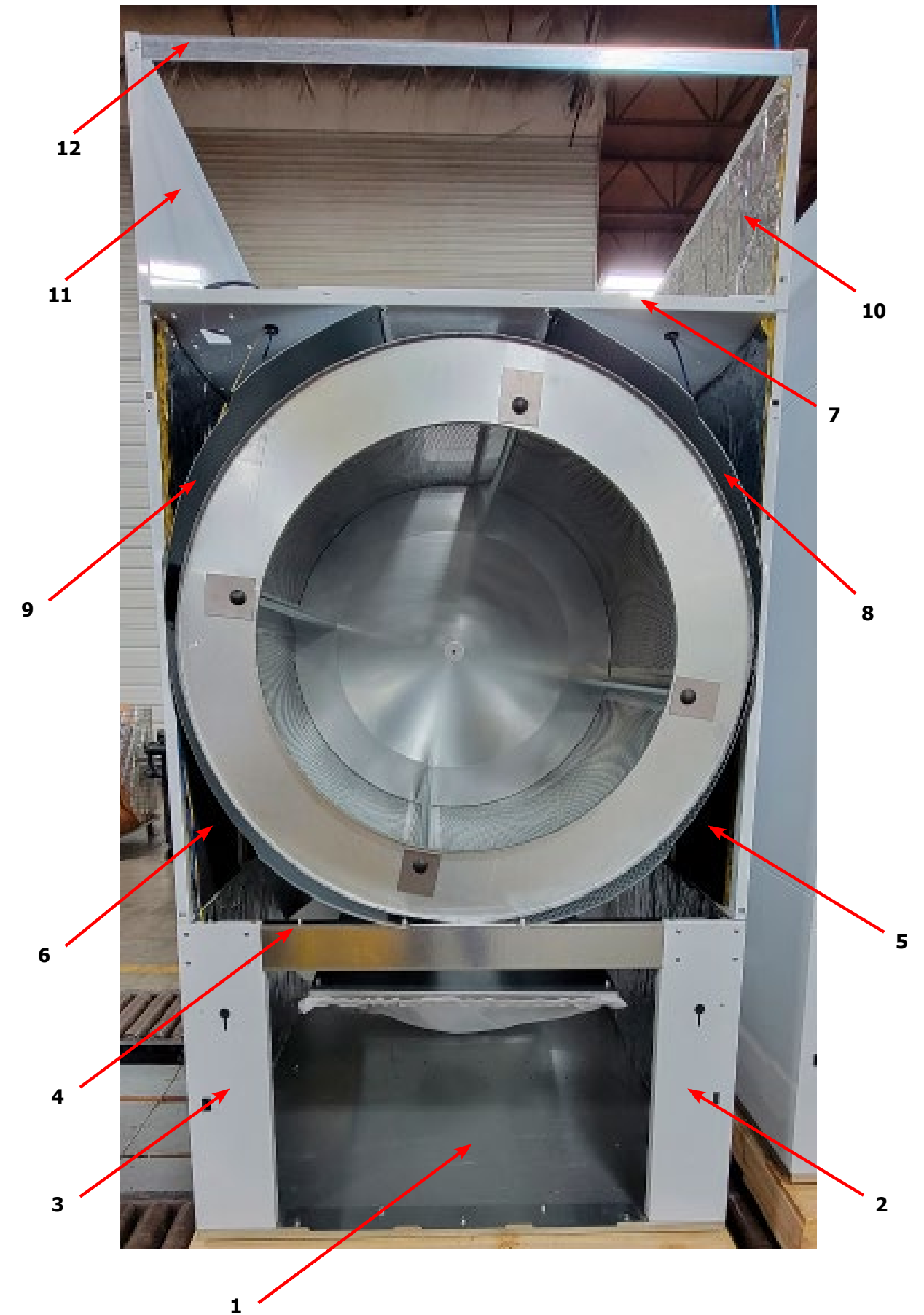

Dryer Modular Cabinet Group (After Serial D1.23090.024)

Key	Description	T80	QTY
1	Cabinet Base Assembly	9945-162-001	1
*	Lower Back Panel Assembly	9989-716-002	1
2	Lower Cabinet RH Side Panel	9444-091-003	1
3	Lower Cabinet LH Side Panel	9444-091-004	1
4	Lower Cabinet Front Channel	9081-217-001	1
*	Upper Back Panel Assembly	9989-717-002	1
5	RH Middle Side Panel Assembly	9989-718-003	1
6	LH Middle Side Panel Assembly	9989-718-004	1
7	Cabinet Top Assembly	9961-163-002	1
8	RH Baffle	9049-129-001	1
9	LH Baffle	9049-129-002	1
*	Baffle Stiffener Angle	9003-384-001	2
10	RH Upper Side Panel	9444-095-003	1
11	LH Upper Side Panel	9444-095-004	1
12	Upper Cross Brace	9046-104-001	1
*	Heavy Hex Nut 7/16-14	8640-416-001	6
*	Spring Lockwasher 7/16	8641-582-013	6
*	10abx3/8 Screw	9545-008-024	28
*	Large Head Pop Rivet	8638-190-028	4
*	3/16 Blind Rivet	9491-009-001	111
*	Wht 3/16 Blind Rivet	9491-009-005	54
*	Hex kep Nut 1/4-20unc, 2b	8640-414-006	10
*	LH Rear Side Angle	9003-326-002	1
*	RH Rear Side Angle	9003-327-002	1

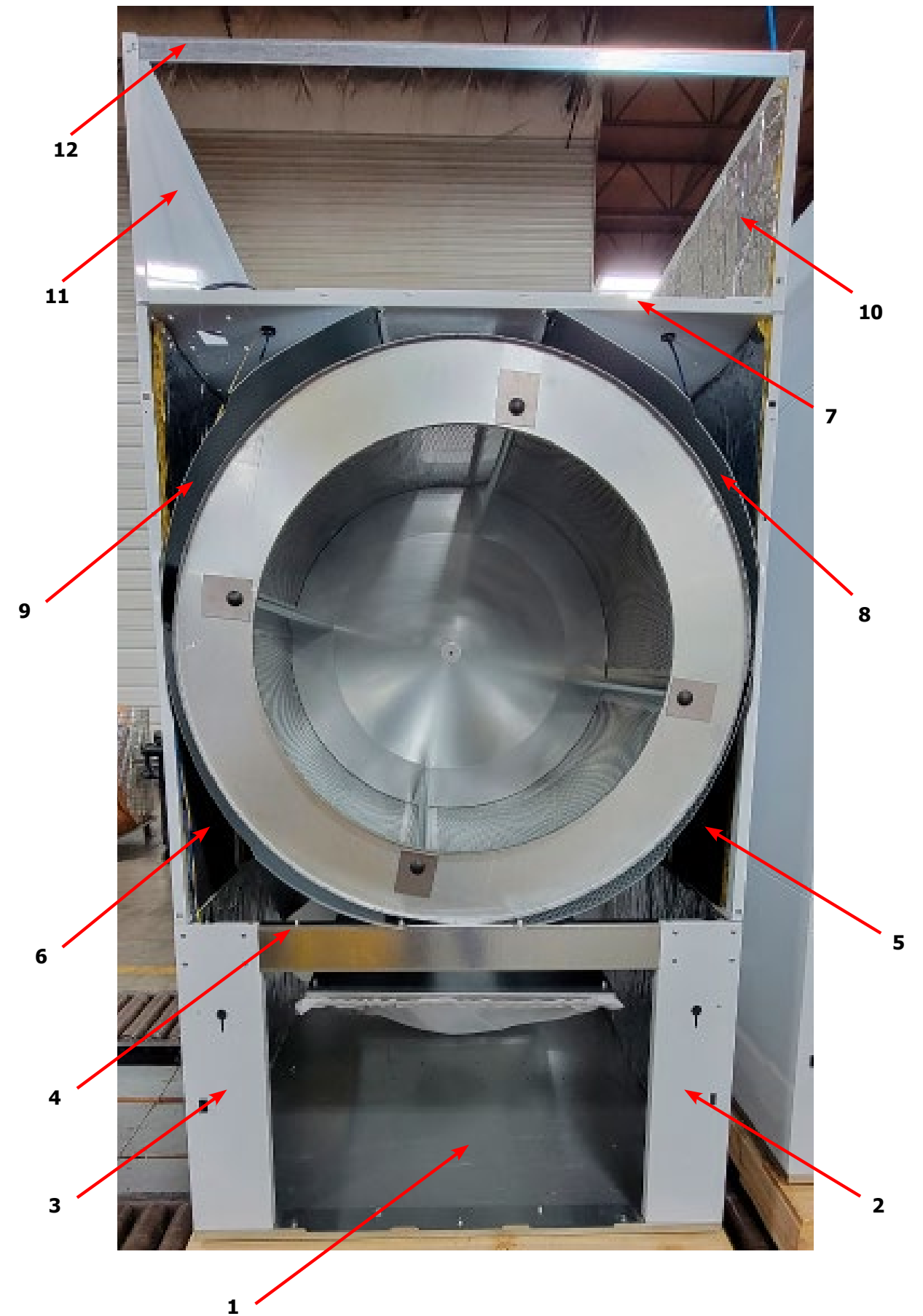

Dryer Rear View 30Lb

Key	Description	T-30	QTY
1	Motor	9376-311-003	1
2	Pulley	9453-157-001	1
*	Set screw	9545-028-013	1
3	Plate, Motor mounting	9982-370-002	1
*	Gasket, Motor Plate	9206-428-001	1
4	Nut-3/8-16, Plate to cabinet	8640-415-004	4
*	Impeller w/set screw	9278-043-001	1
5	Screw, 5/16-18x5/8	9545-014-004	4
6	Nut, 3/8-16	8640-415-004	4
7	Support Arm, Intermediate pulley	9991-053-001	1
8	Bolt- 3/8-16x1 1/4	9545-029-010	3
9	Nut, Wizlock, 3/8x16	8640-415-004	3
*	Cap Screw, 3/8-16x1 1/2	9545-029-003	1
*	Snap Ring	9487-200-003	1
*	Washer-Flat, 3/8x1	8641-581-035	1
10	Idler Arm Assembly	9861-022-001	1
11	Washer-Flat, 3/8x1	8641-581-035	2
12	Pulley, Idler w/Bearings	9908-039-004	1
13	Bearing, Bronze	9036-145-002	2
14	Snap Ring	9487-200-003	1
15	Hook "S" type	9248-022-002	3
16	Chain, Spring tension	9099-012-002	1
17	Spring, tension	9534-319-002	1
18	Chain, Limit	9099-012-007	1
19	Belt Drive	9040-076-003	1
*	Tolerance Ring	9487-234-005	1
20	Pulley, Driven	9908-049-002	1
21	Washer-Flat, 1/2	8641-581-021	1
22	Washer-Lock, Ext. tooth, 1/2	8641-582-016	1
23	Bolt-3/4, 1/2-13x1 1/4	9545-017-009	1
24	Belt, Driven	9040-073-009	1

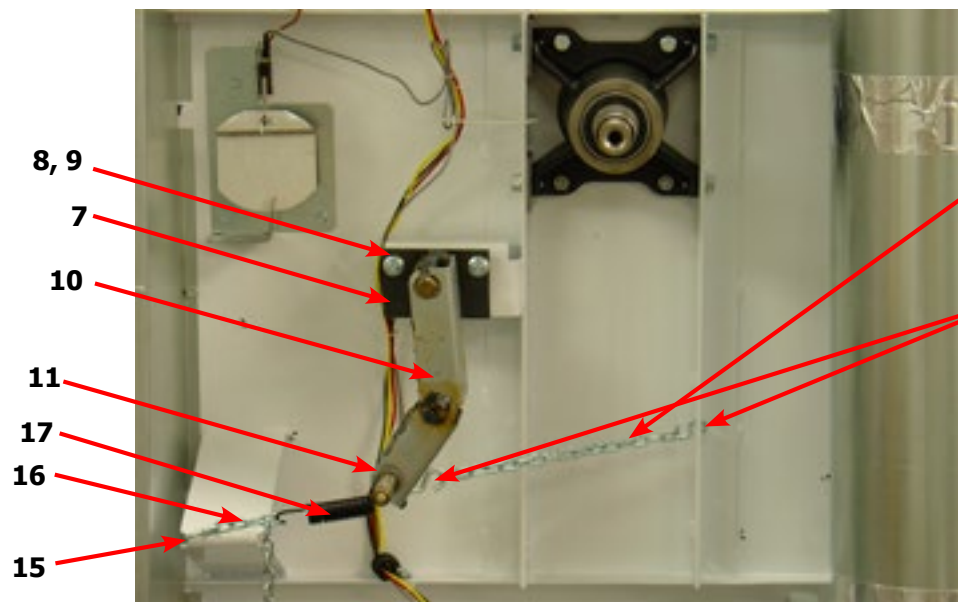

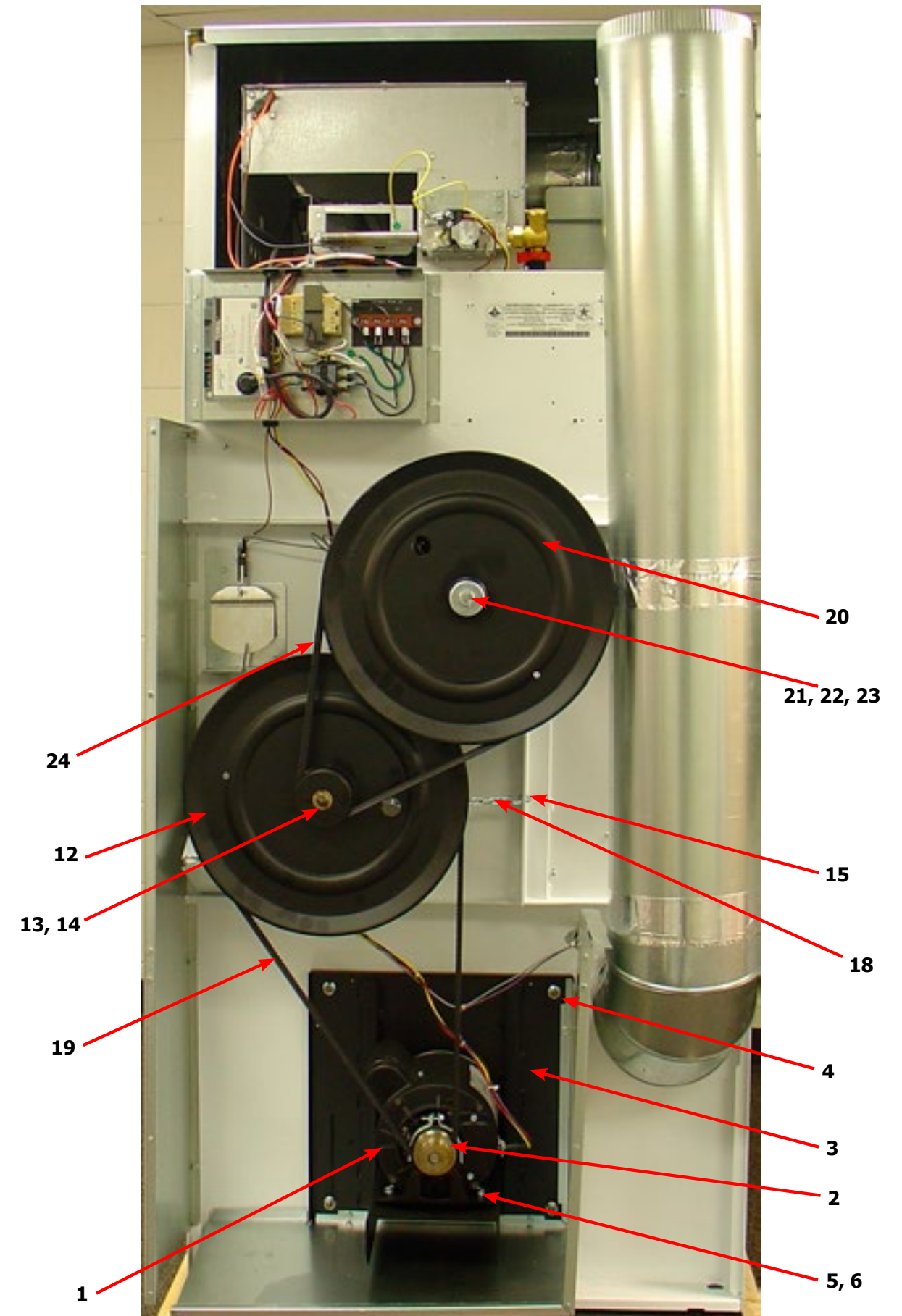

**Scroll down for
50lb and 80lb
Parts Breakdown**

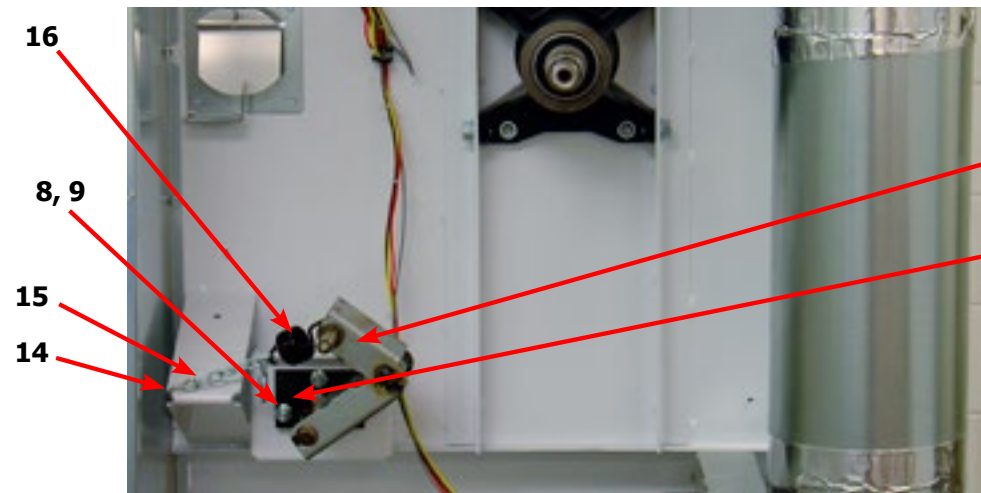
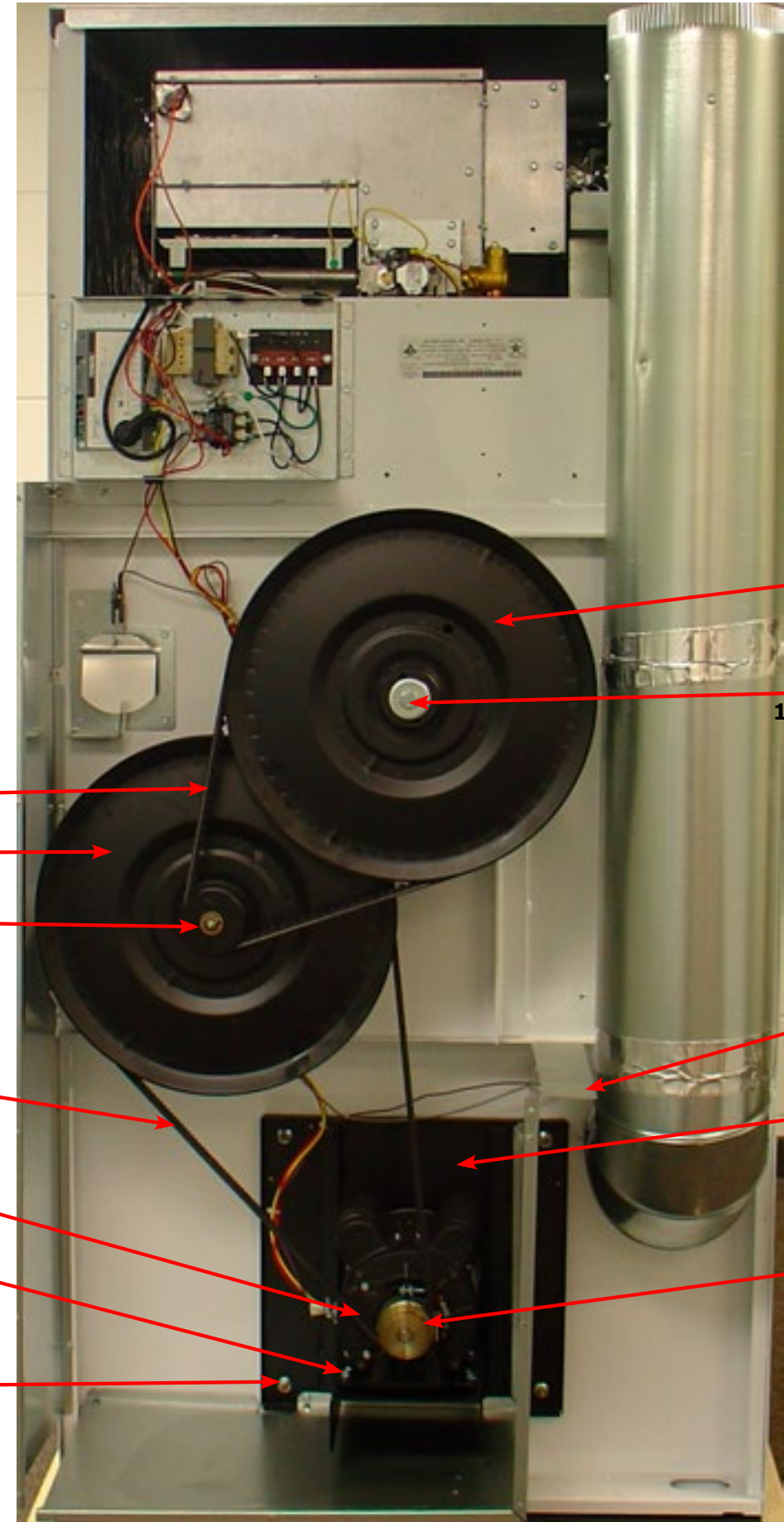

Key	Description	T-50	QTY
1	Motor	9376-317-003	1
*	Run Capacitor, Motor	5191-108-001	1
*	Start Capacitor, Motor	5191-109-001	1
2	Pulley	9453-169-013	1
*	Set screw	9545-028-013	1
3	Plate, Motor mounting	9982-370-002	1
*	Gasket, Motor Plate	9206-428-002	1
4	Nut-3/8-16, Plate to cabinet	8640-415-004	4
*	Impeller w/set screw	9278-038-004	1
5	Screw, 5/16-18x5/8	9545-014-004	4
6	Nut, 3/8-16	8640-415-004	4
7	Support Arm, Intermediate pulley	9991-053-002	1
8	Bolt- 3/8-16x1 1/4	9545-029-010	3
9	Nut, Wizlock, 3/8x16	8640-415-004	3
*	Cap Screw, 3/8-16x1 1/2	9545-029-012	1
*	Snap Ring	9487-200-003	1
*	Washer-Flat, 3/8x1	8641-581-035	1
10	Idler Arm Assembly	9861-022-002	1
*	Snap Ring (Support Arm keeper)	9487-200-003	1
*	Snap Ring	9487-200-003	1
*	Washer-Flat, 3/8x1	8641-581-035	1
11	Pulley, Idler w/Bearings	9908-048-003	1
12	Bearing, Bronze	9036-145-002	2
13	Snap Ring	9487-200-003	1
14	Hook "S" type	9248-022-002	3
15	Chain, Spring tension	9099-012-002	1
16	Spring, tension	9534-369-001	1
17	Belt Drive	9040-076-006	1
*	Tolerance Ring	9487-234-005	1
18	Pulley, Driven	9908-047-002	1
19	Washer-Flat, 1/2	8641-581-026	1
20	Washer-Lock, Ext. tooth, 1/2	8641-582-016	1
21	Bolt-3/4, 1/2-13x1/14	9545-017-009	1
22	Belt, Driven	9040-073-011	1
23	Thermostat-Overtemp, Reset	9576-207-006	1

Dryer Rear View 50 Lb



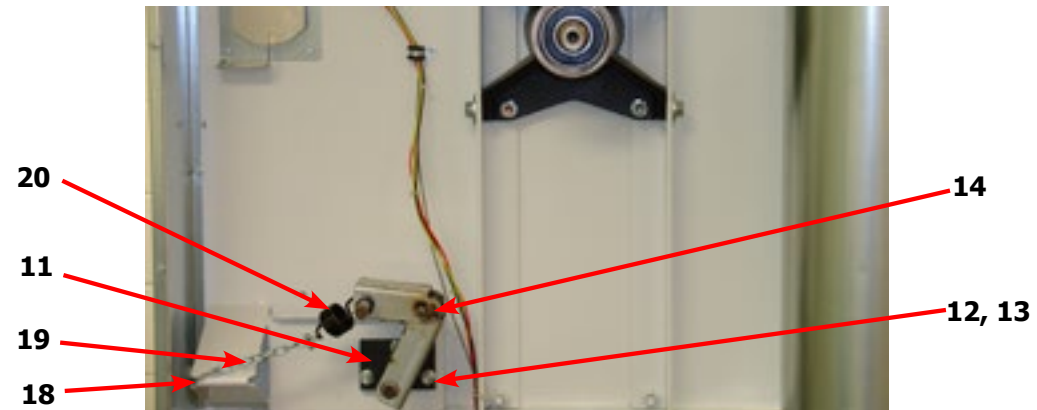

**Scroll down for
80lb Parts
Breakdown**

Key	Description	T-80	QTY
1	Motor	9376-317-003	1
*	Run Capacitor, Motor	5191-108-001	1
*	Start Capacitor, Motor	5191-109-001	1
2	Pulley	9453-157-001	1
*	Set screw	9545-028-013	1
3	Plate, Motor mounting	9982-372-002	1
*	Gasket, Motor Plate	9206-428-001	1
4	Nut-3/8-16, Plate to cabinet	8640-415-004	4
*	Impeller w/set screw	9278-037-003	1
5	Screw, 5/16-18x5/8	9545-014-004	4
6	Nut, 35/16-18	8640-400-003	4
*	Tolerance Ring	9487-234-001	1
7	Pulley, Driven	9908-043-002	1
8	Washer-Flat, 1/2	8641-581-026	1
9	Washer-Lock, Ext. tooth, 1/2	8641-582-016	1
10	Bolt-3/4, 1/2-13x1/4	9545-017-009	1
11	Support Arm, Intermediate pulley	9991-053-002	1
12	Bolt- 3/8-16x1 1/4	9545-029-010	3
13	Nut, Wizlock, 3/8x16	8640-415-004	3
*	Cap Screw, 3/8-16x1 1/2	9545-029-012	1
*	Snap Ring	9487-200-003	1
*	Washer-Flat, 3/8x1	8641-581-035	1
14	Idler Arm Assembly	9861-024-004	1
*	Snap Ring	9487-200-006	
*	Washer-Flat, 3/8x1	8641-581-039	1
15	Pulley, Idler w/Bearings	9908-042-006	1
*	Snapping, Inside-Bearing	9487-238-005	1
*	Bearing, Ball	9036-159-007	2
*	Spacer, Bearing	9538-173-002	1
16	Washer-Flat	8641-581-039	1
17	Nut, 5/8-11	8640-425-002	1
18	Hook "S" type	9248-022-002	3
19	Chain, Spring tension	9099-012-002	1
20	Spring, tension	9534-369-001	1
21	Belt Drive	9040-076-011	1
22	Belt, Driven	9040-073-012	1
23	Thermostat-Overtemp, Reset	9576-207-006	1

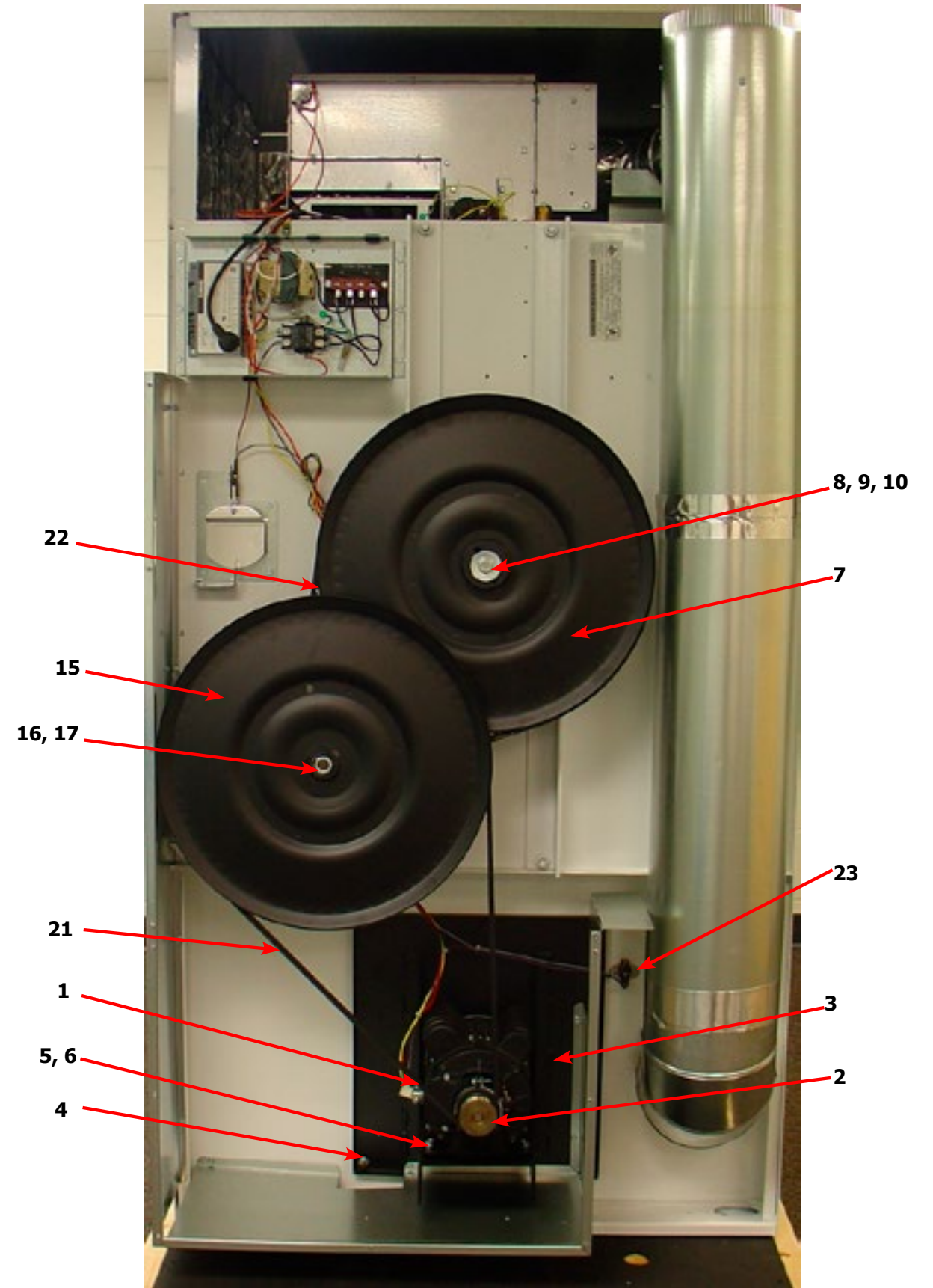

Dryer Rear View 80 Lb



Dryer Rear View-Guard & Exhaust

Key	Description	T-30	T-50	T80	QTY
1	Cover Cabinet	9074-347-001	9074-348-001	9074-349-001	1
*	Screw-5/16, 10ABx3/8	9545-008-024	9545-008-024	9545-008-024	AR
2	Cover-Control Box	9074-346-001	9074-346-001	9074-346-001	1
3	Screw-5/16, 10ABx3/8	9545-008-024	9545-008-024	9545-008-024	AR
4	Guard, RH	9208-093-001	9208-097-001	9208-101-001	1
*	Screw-5/16, 10ABx3/8	9545-008-024	9545-008-024	9545-008-024	AR
5	Guard Base & LH	9208-094-001	9208-098-001	9208-102-001	1
*	Screw-5/16, 10ABx3/8	9545-008-024	9545-008-024	9545-008-024	AR
6	Guard-Lower	9208-095-001	9208-099-001	9208-103-001	1
7	Screw-5/16, 10ABx3/8	9545-008-024	9545-008-024	9545-008-024	AR
8	Guard-upper	9208-096-001	9208-100-001	9208-104-001	1
*	Screw-5/16, 10ABx3/8	9545-008-024	9545-008-024	9545-008-024	AR
9	Elbow-90 degree, 8"	9142-039-001	9142-039-001	9142-039-001	1
10	Pipe-Duct, 8"	9109-121-001	9109-121-001	9109-121-002	1
11	Tee-Duct, Recirculation, 8"-6"	9810-018-001	9810-018-001	9810-019-001	1
12	Damper	9125-002-001	9125-002-001	9125-008-001	1
*	Pin-Damper, Hinge	9451-146-002	9451-146-002	9451-146-002	1
*	Nut-Spring	8520-141-000	8520-141-000	8520-141-000	2
13	Bracket-Recirculation Duct, Small	9029-228-001	9029-228-001	9029-228-001	1
14	Pipe-Duct, 6"	9109-122-001	9109-122-002	9109-122-003	1
15	Bracket-Duct, Recirculation Large	9029-246-001	9029-247-001	9029-247-001	1
16	Elbow-90 degree, 6"	9142-039-002	9142-039-002	9142-039-002	1
*	Booklet-Owners	8514-208-001	8514-208-001	8514-208-001	1
17	Diagram & Schematics	9506-474-001	9506-474-001	9506-474-001	1
18	Label-Warning & Notice	8502-600-001	8502-600-001	8502-600-001	1
19	Label-Instructions	8502-645-001	8502-645-001	8502-645-001	1
20	Decal-Lighting & Clearance	8527-151-001	8527-151-001	8527-151-001	1
21	Label-High Voltage	8502-614-004	8502-614-004	8502-614-004	1
*	8" Slide Open Clean Out Duct	9973-034-001	9973-034-001	9973-034-001	1

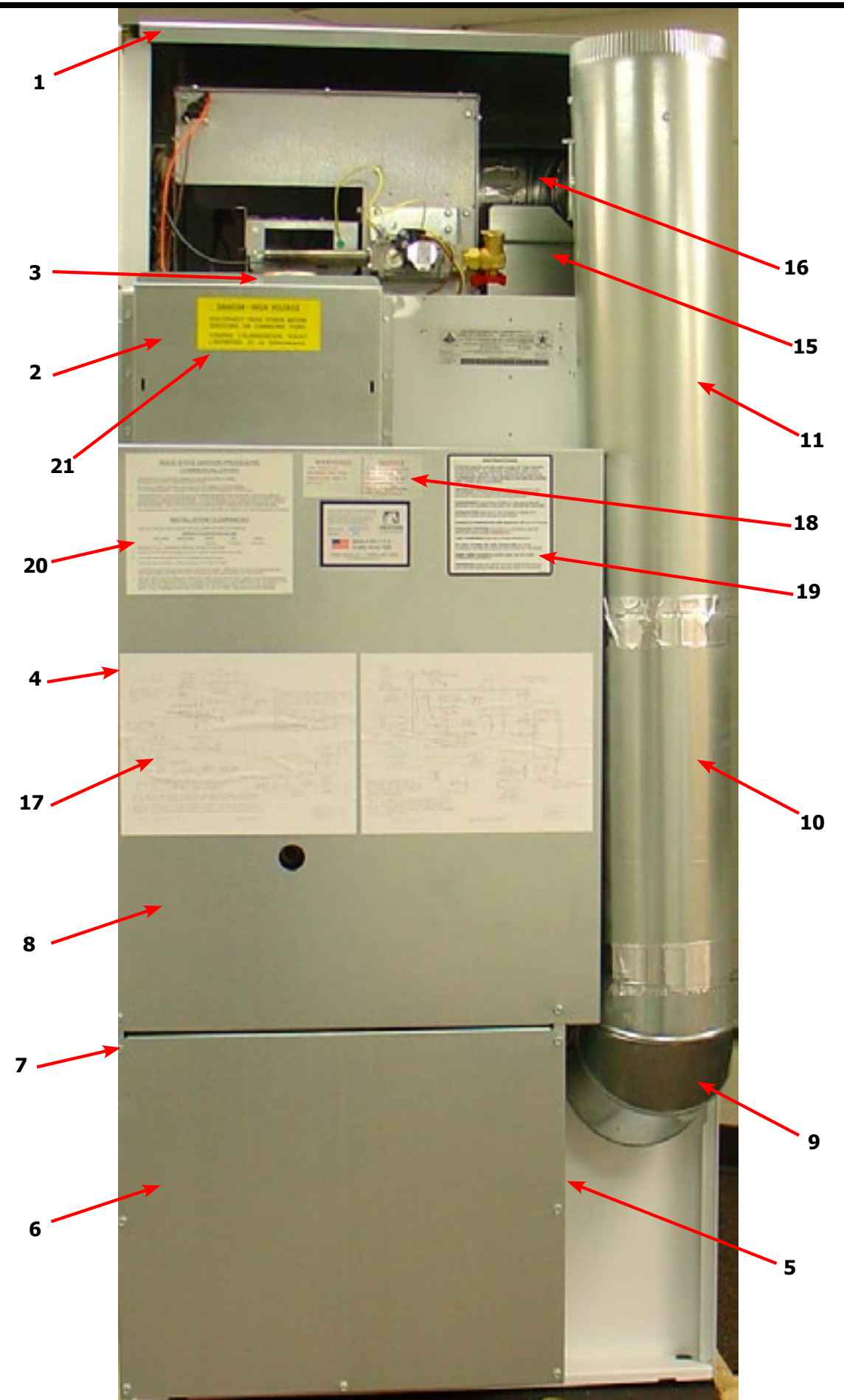
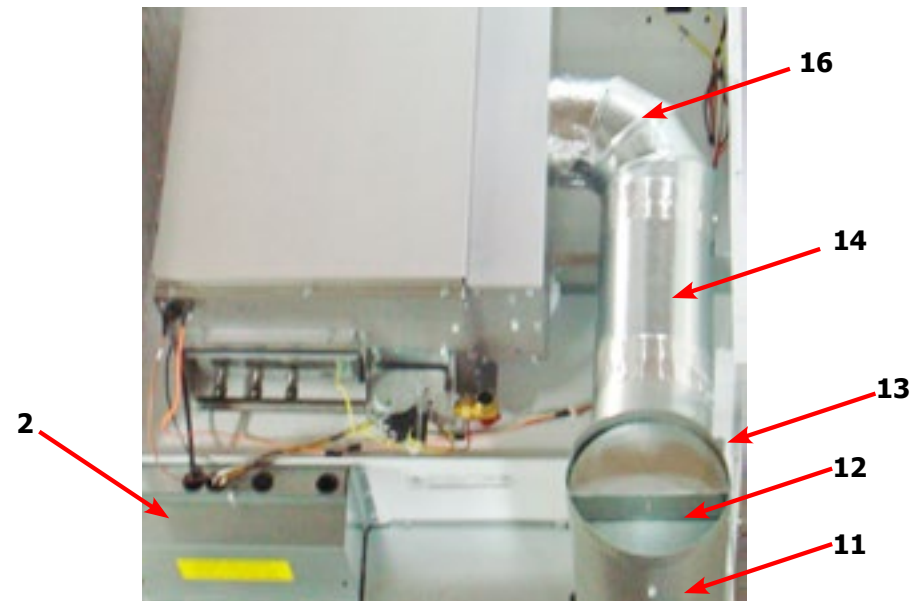

Dryer Rear View-Bearing Housing 30Lb

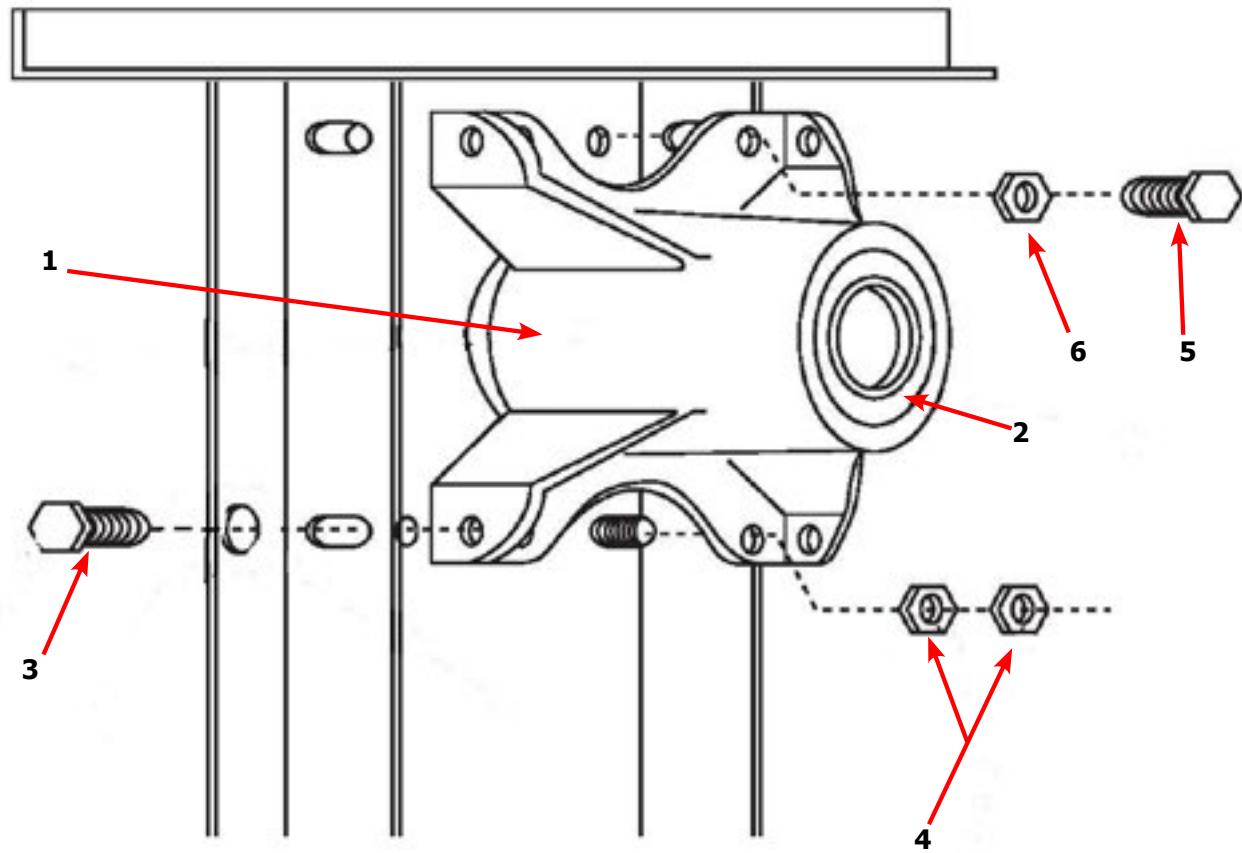

Key	Description	T-30	QTY
*	Bearing Housing Complete Assy (Includes bearings & Spacer)	9803-160-003	1
1	Housing, Bearing	9241-161-002	1
*	Bearing, Ball, Front	9036-130-001	1
*	Spacer, Bearing	9538-139-002	1
2	Bearing, Ball, Rear	9036-130-001	1
3	Screw-Wizlock, 3/8-24x3/4	9545-049-002	4
4	Nut, 5/16-18	8640-400-002	4
5	Screw, 3/8-24x1	9545-049-001	2
6	Nut, 3/8-24	8640-415-002	2
*	Shim, Tumbler	9538-139-002	AR

↓ Scroll down for
50lb and 80lb
Parts Breakdown

Dryer Tumbler Group 30Lb

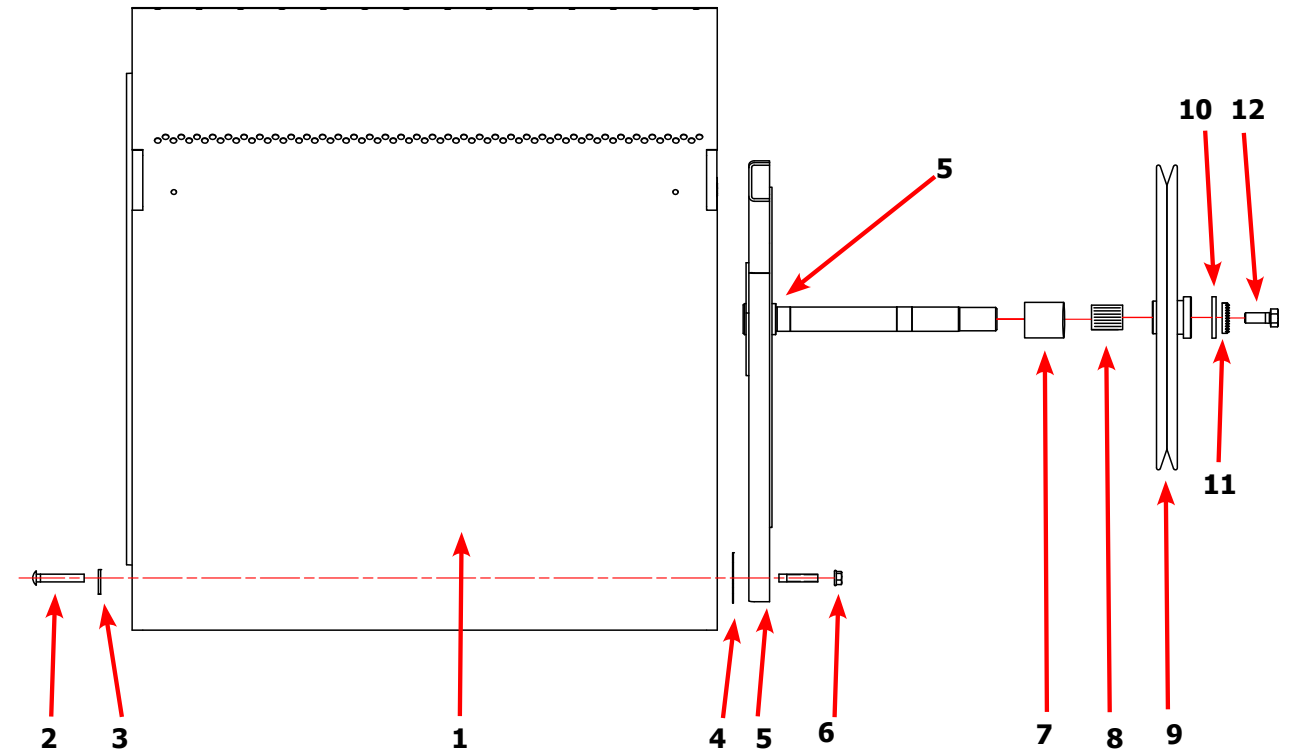

Key	Description	T-30	QTY
*	Tumbler Assy Complete W/Spider (GALV)	9848-147-001	1
1	Tumbler Assy (Galvanized)	9848-146-001	1
1	Tumbler Assy Complete W/Spider (SS & Galv front)	9848-147-002	1
1	Tumbler Assy (Stainless Galvanized front)	9848-146-002	1
2	Rod, Tumbler	9497-019-003	3
3	Washer, Special	8641-554-001	3
4	Shim	9552-013-003	AR
5	Spider Assy	9568-015-001	1
6	Nut, Wiz Lock	8640-415-004	3
7	Spacer-Shaft	9538-164-002	1
8	Tolerance Ring	9487-234-005	1
9	Pulley, Driven	9908-049-002	1
10	Washer -Flat	8641-581-026	1
11	LockWasher - IntTooth, 1"	8641-582-016	1
12	Screw, 1/2-13x1 1/4	9545-017-009	1

↓ Scroll down for
50lb and 80lb
Parts Breakdown

Dryer Rear View-Bearing Housing 50Lb

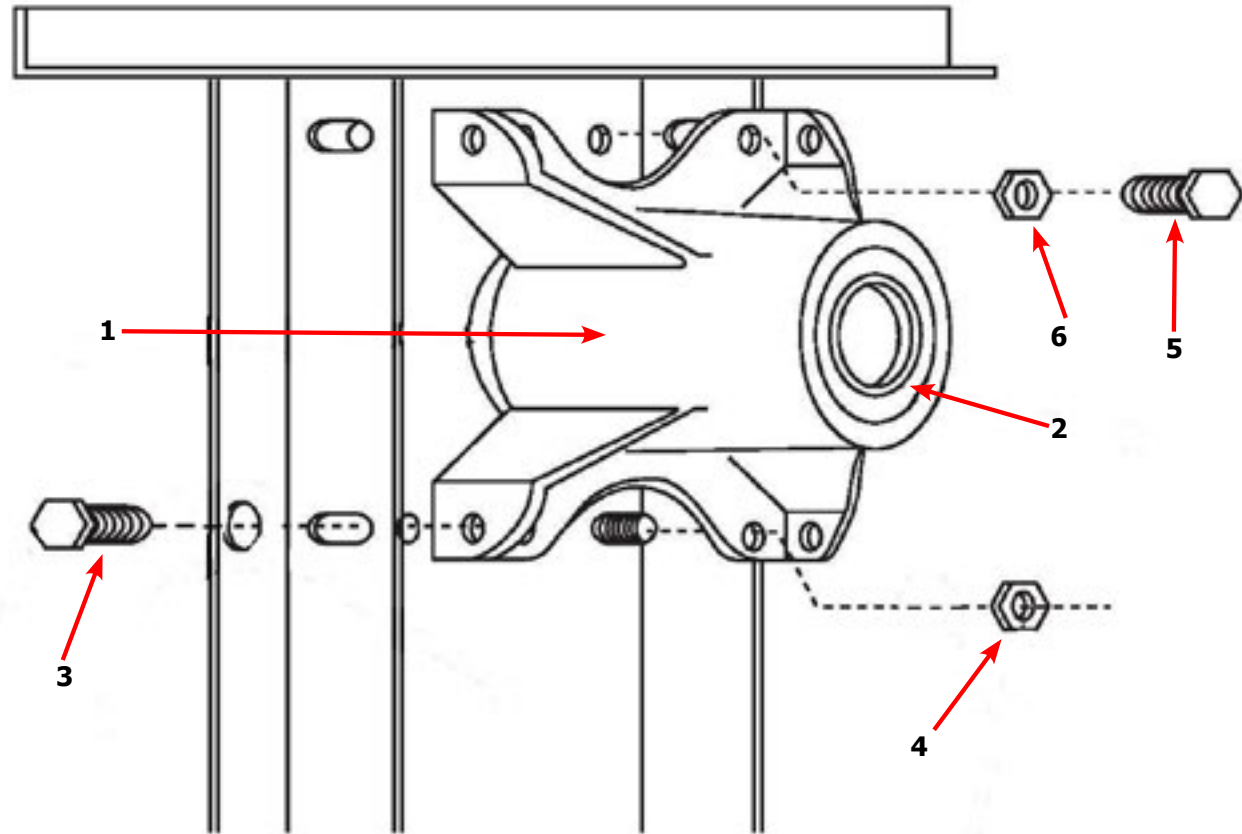

Key	Description	T-50	QTY
	Bearing Housing Complete Assy (Includes bearings & Spacer)	9803-201-001	1
1	Housing, Bearing	9241-189-002	1
*	Bearing, Ball, Front	9036-159-001	1
*	Spacer, Bearing	9538-183-001	1
2	Bearing, Ball, Rear	9036-159-003	1
3	Screw-Wizlock, 1/2-13x3/4	9545-017-017	4
4	Nut, 1/2-13	8640-417-002	2
5	Screw, 1/2-13x1 1/2	9545-017-018	2
6	Nut, 1/2-13	8640-417-002	2

↓ **Scroll down for
80lb Parts
Breakdown**

Dryer Tumbler Group 50Lb

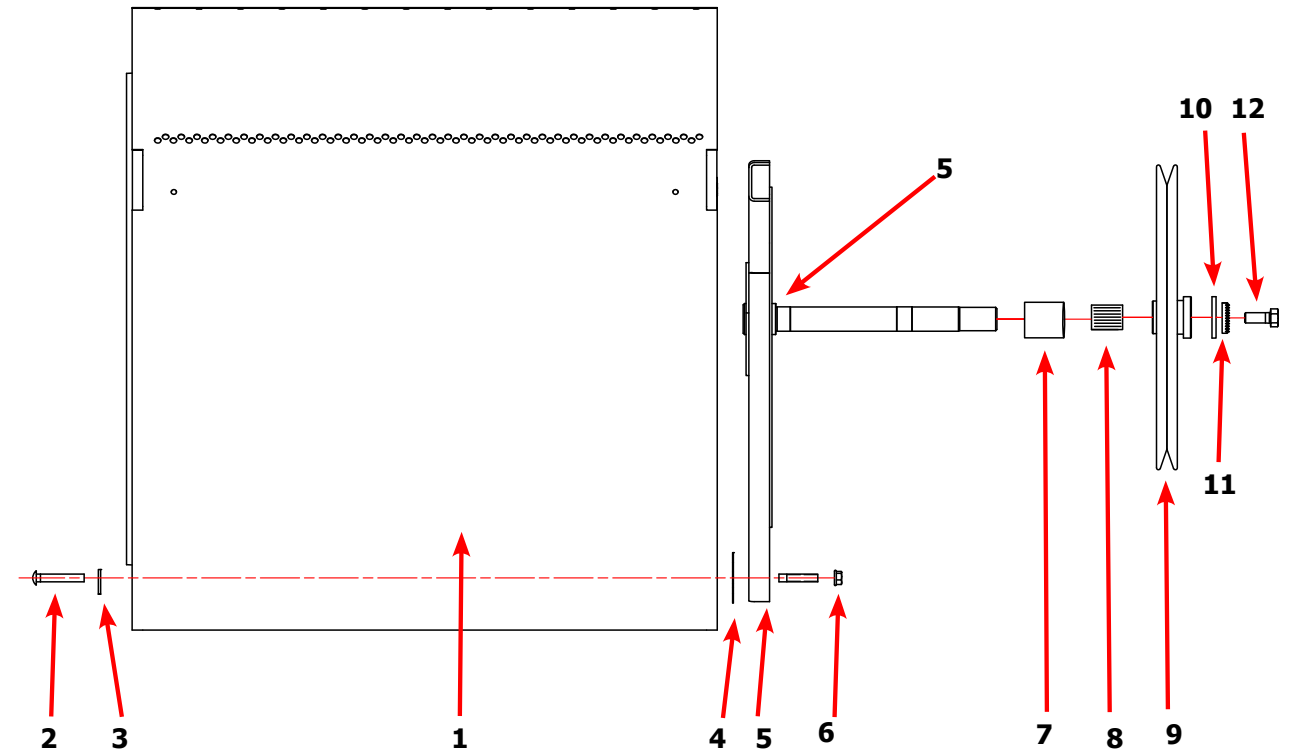

Key	Description	T-50	QTY
*	Tumbler Assy Complete W/Spider (GALV)	9848-149-001	1
1	Tumbler Assy (Galvanized)	9848-148-001	1
*	New Tumbler Assy, Taller Baffles (Anti-Roping) W/Spider	9848-158-001	1
*	New Tumbler Assy, Taller Baffles (Anit-Roping)	9848-157-001	1
*	Tumbler Assy Complete W/Spider (SS & Galv front)	9848-149-002	1
1	Tumbler Assy (Stainless Galvanized front)	9848-148-002	1
2	Rod, Tumbler	9497-226-002	3
3	Washer, Special	8641-590-002	3
4	Shim	9552-013-000	AR
5	Spider Assy	9568-013-001	1
6	Nut, Wiz Lock	8640-417-005	3
7	Spacer-Shaft	9538-184-001	1
8	Tolerance Ring	9487-234-005	1
9	Pulley, Driven	9908-047-002	1
10	Washer -Flat	8641-581-026	1
11	LockWasher - IntTooth, 1"	8641-582-016	1
12	Screw, 1/2-13x1 1/4	9545-017-009	1

↓ **Scroll down for
80lb Parts
Breakdown**

Dryer Rear View-Bearing Housing 80Lb

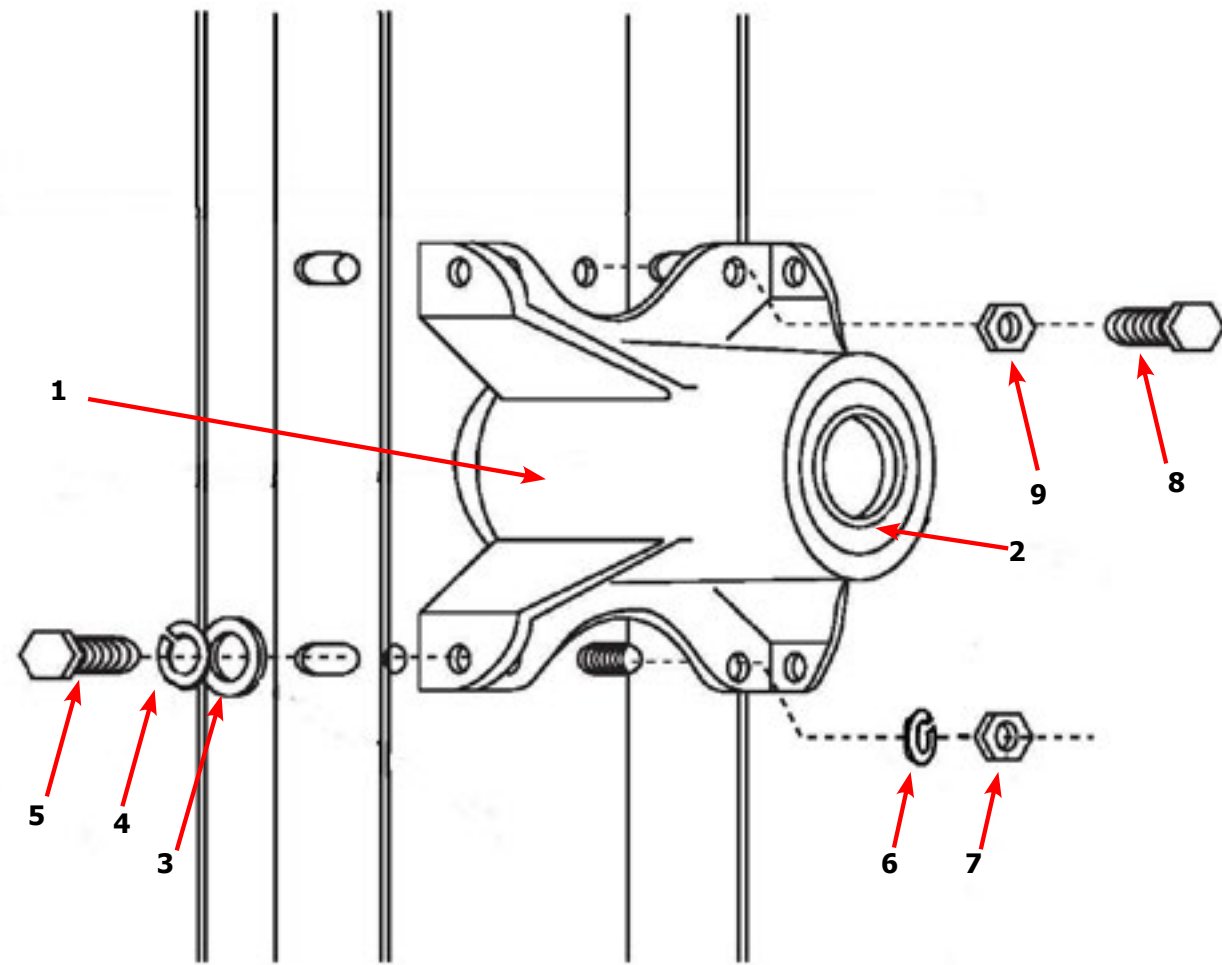

Key	Description	T80	QTY
	Bearing Housing Complete Assy (Includes bearings & Spacer)	9803-189-001	
1	Housing, Bearing	9241-183-003	
*	Bearing, Ball, Front	9036-159-001	
*	Spacer, Bearing		
2	Bearing, Ball, Rear	9036-159-002	
3	Washer, Flat 1/2	8641-581-026	
4	Lock Washer Spring, 1/2	8641-582-004	
5	Screw, 1/2-13x1	9545-017-004	
6	Lock Washer Spring, 1/2	8641-582-004	
7	Nut, 7/16-14	8640-416-001	
8	Screw, 7/16-14x1 1/2	9545-059-003	
9	Nut, 7/16-14	8641-416-001	

Dryer Tumbler Group 80Lb

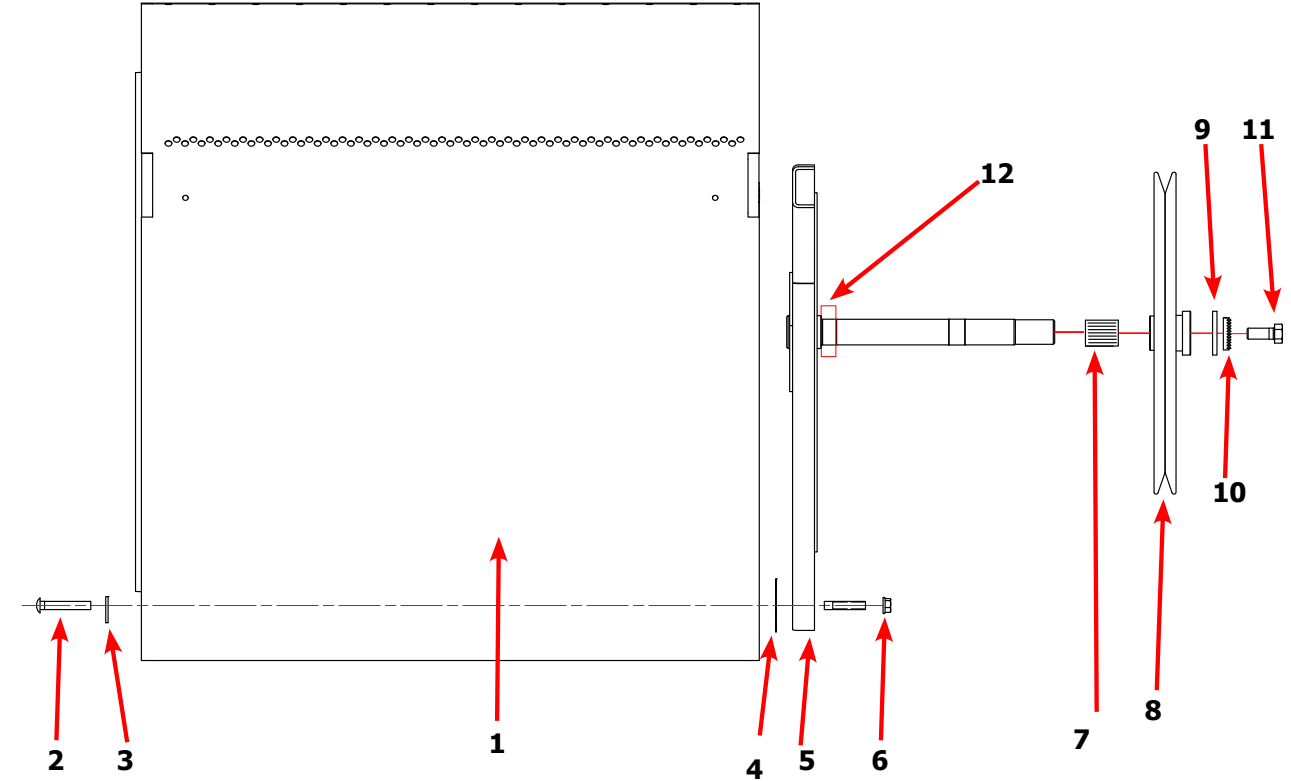

Key	Description	T80	QTY
*	Tumbler Assy Complete W/Spider (GALV)	9848-151-001	1
1	Tumbler Assy (Galvanized)	9848-150-001	1
1	Tumbler Assy Complete W/Spider (SS & Galv front)	9848-151-002	1
1	Tumbler Assy (Stainless Galvanized front)	9848-150-002	1
2	Rod, Tumbler	9497-266-001	4
3	Washer, Special	8641-590-001	4
4	Shim	9552-013-000	AR
5	Spider Assy w/Front Bearing	9873-008-001	1
6	Nut, Wiz Lock	8640-417-005	4
7	Tolerance Ring	9487-234-001	1
8	Pulley, Driven	9908-043-002	1
9	Washer -Flat	8641-581-026	1
10	LockWasher - IntTooth, 1"	8641-582-016	1
11	Screw, 1/2-13x1 1/4	9545-017-009	1
12	Bearing, Front	9036-159-002	1

Dryer Burner Housing Group 30Lb

Key	Description	Part Number	Qty
*	Housing Assembly, Burner	9803-210-001	1
1	Panel-Burner Housing, Side Left	9454-845-001	1
2	Baffle-Burner Housing, Center	9049-091-001	1
3	Panel-Burner Housing, Top	9454-871-001	1
4	Panel-Burner Housing, Front	9454-847-001	1
5	Panel-Burner Housing, Back	9454-848-001	1
6	Baffle-Burner Housing, Recirculation	9049-092-001	1
7	Baffle-Burner Housing, Front	9049-093-001	1
8	Duct Adaptor, 6"x3" long	9109-120-001	1
9	Burner, Main	9048-021-001	2
10	Bracket-Support, Electrode	9029-214-001	1
11	Bracket-Support, Gas Valve	9029-227-001	1
12	Electrode-Ignition	9875-002-003	1
13	Control Assy, Gas Valve, White Rodgers 36J	9857-192-001	1
14	Manifold Assy	9381-009-007	1
15	Valve-Gas Shutoff, (Optional)	9379-196-001	1
16	Thermostat-HI-Limit	9576-203-002	
17	Screw, 10ABx3/8	9545-008-024	24
18	Screw, 10ABx1/4	9545-008-001	17
19	Orifice-Natural, .125	9425-069-023	2
*	Orifice-LP, #48	9425-069-003	2
*	Kit, LP Conversion, White Rodgers	9732-102-018	1
20	Bracket-Support, Burner	9029-225-001	1
21	Panel-Burner Housing, Side Right	9454-861-001	1
22	Screw, 10-32TTx1/2 Green	9545-008-027	3
23	Screw, 8-32x3/8	9545-010-014	4

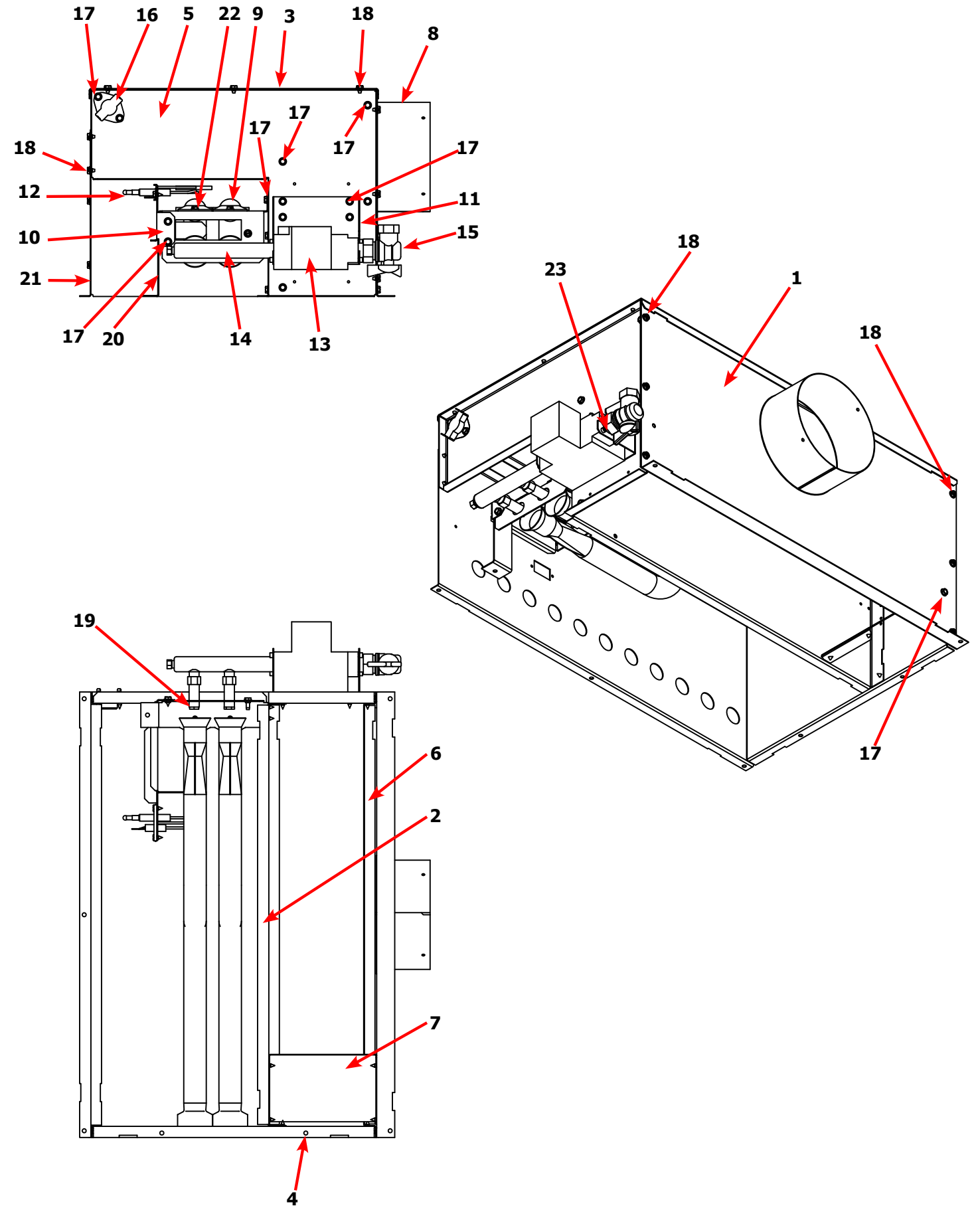



**Scroll down for
50lb and 80lb
Parts Breakdown**

Dryer Burner Housing Group 50Lb

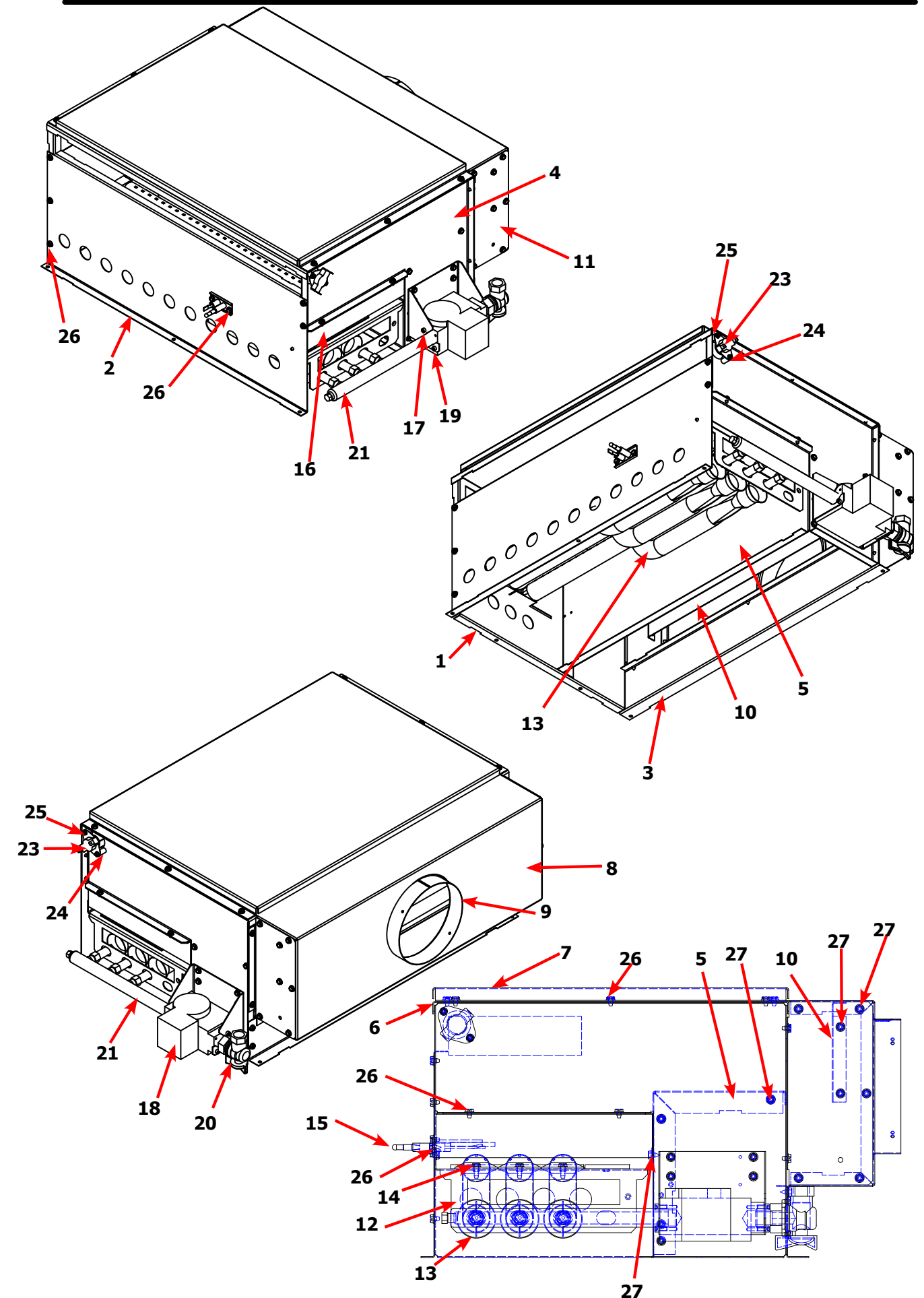
Key	Description	Part Number	Qty
	Housing Assembly, Burner	9803-211-001	1
1	Panel-Burner Housing, Front	9454-863-001	1
2	Panel-Burner Housing, Side Right	9454-861-001	1
3	Panel-Burner Housing, Side Left	9454-862-001	1
4	Panel-Burner Housing, Back	9454-864-001	1
5	Baffle-Burner Housing, Center	9049-098-001	1
6	Panel-Burner Housing, Top	9454-849-001	1
7	Panel-Burner Housing, Top	9074-343-001	1
8	Baffle-Burner Housing, Extention	9049-100-001	1
9	Duct Adaptor, 6"x1.25" long	9109-120-003	1
10	Baffle-Burner Housing, Recirculation	9049-099-001	1
11	Side-Extention Baffle, Burner Housing	9551-049-001	2
12	Bracket-Support, Burner	9029-213-001	1
13	Burner, Main	9048-021-001	3
14	Screw, 10T-32x1/2	9545-008-008	3
15	Electrode-Ignition	9875-002-003	1
16	Cover-Burner, Intet	9074-344-001	1
17	Bracket-Support, Gas Valve	9029-227-001	1
18	Control Assy, Gas Valve, White Rodgers 36J	9857-192-001	1
19	Screw, #8-32x3/8	9545-010-014	4
20	Valve-Gas Shutoff, (Optional)	9379-196-001	1
21	Manifold Assy	9381-010-003	1
*	Orfice-Natural, #30	9425-069-002	3
*	Orfice-LP, #48	9425-069-003	3
*	Kit, LP Conversion, White Rodgers	9732-102-017	1
23	Thermostat-HI-Limit	9576-203-002	1
24	Spacer-1/4x5/8 long	9538-166-009	2
25	Screw-8Bx1	9545-045-013	2
26	Screw, 10Bx1/4	9545-008-001	22
27	Screw, 10ABx3/8	9545-008-024	31





**Scroll down for
80lb Parts
Breakdown**

Dryer Burner Housing Group 80Lb

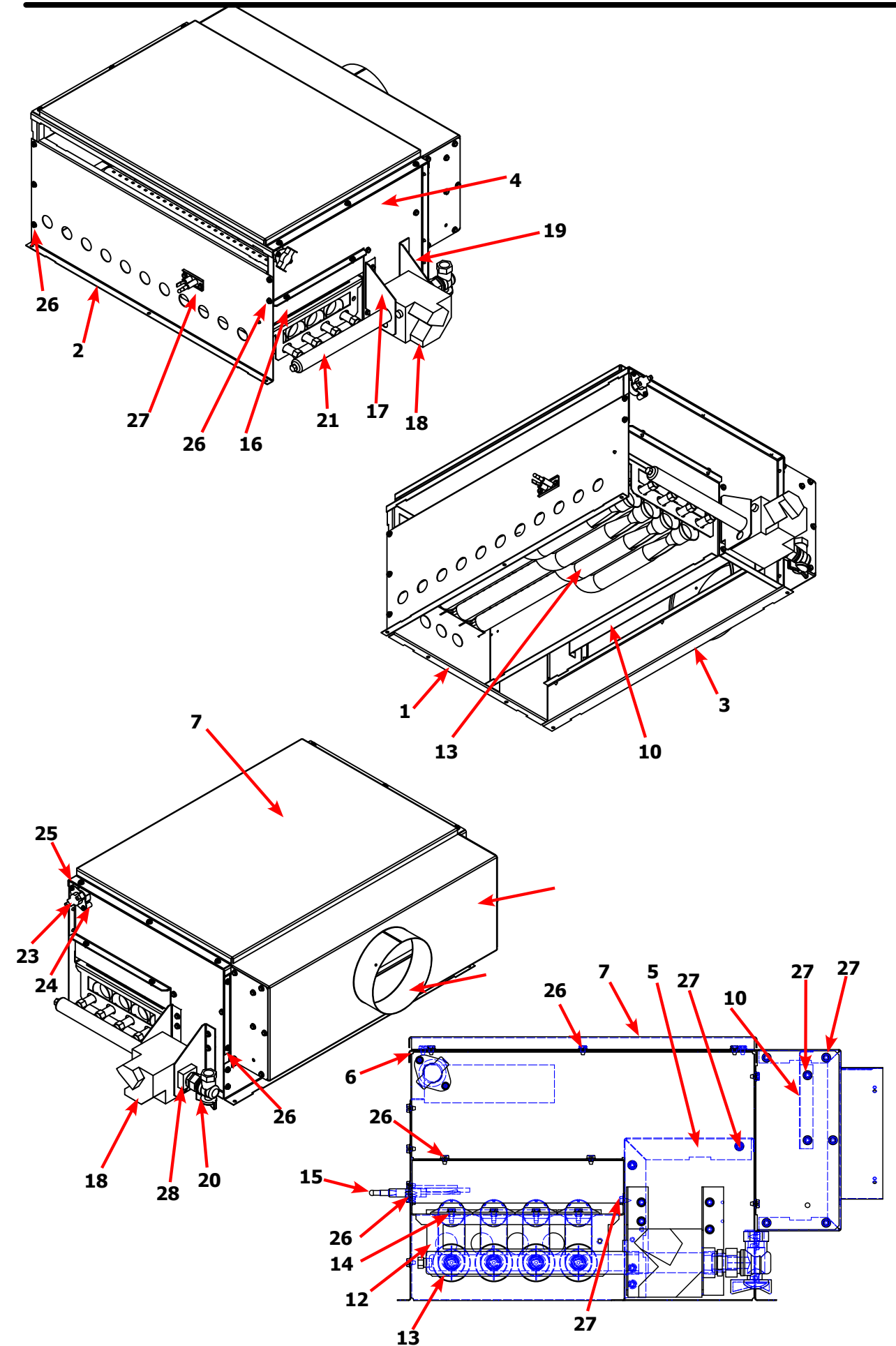
Key	Description	Part Number	Qty
	Housing Assembly, Burner	9803-212-001	1
1	Panel-Burner Housing, Front	9454-863-001	1
2	Panel-Burner Housing, Side Right	9454-861-001	1
3	Panel-Burner Housing, Side Left	9454-862-001	1
4	Panel-Burner Housing, Back	9454-864-001	1
5	Baffle-Burner Housing, Center	9049-098-001	1
6	Panel-Burner Housing, Top	9454-849-001	1
7	Panel-Burner Housing, Top	9074-343-001	1
8	Baffle-Burner Housing, Extention	9049-100-001	1
9	Duct Adaptor, 6"x1.25" long	9109-120-002	1
10	Baffle-Burner Housing, Recirculation	9049-099-001	1
11	Side-Extention Baffle, Burner Housing	9551-049-001	2
12	Bracket-Support, Burner	9029-213-001	1
13	Burner, Main	9048-021-001	4
14	Screw, 10T-32x1/2	9545-008-008	4
15	Electrode-Ignition	9875-002-003	1
16	Cover-Burner, Intet	9074-344-001	1
17	Bracket-Support, Gas Valve	9029-234-001	1
18	Control Assy, Gas Valve, White Rodgers 36J	9857-193-001	1
19	Bracket-support, Gas Valve Left hand	9029-235-001	4
20	Valve-Gas Shutoff, (Optional)	9379-196-001	1
21	Manifold Assy	9381-014-001	1
22	Orifice-Natural, #29	9425-069-021	4
*	Orifice-LP, #46	9425-069-022	4
*	Kit, LP Conversion, White Rodgers	9732-102-023	1
23	Thermostat-HI-Limit	9576-203-002	1
24	Spacer-1/4x5/8 long	9538-166-009	2
25	Screw-8Bx1	9545-045-013	2
26	Screw, 10Bx1/4	9545-008-001	22
27	Screw, 10ABx3/8	9545-008-024	31
28	Bushing-Reducer, 3/4x1/2	8615-104-009	1

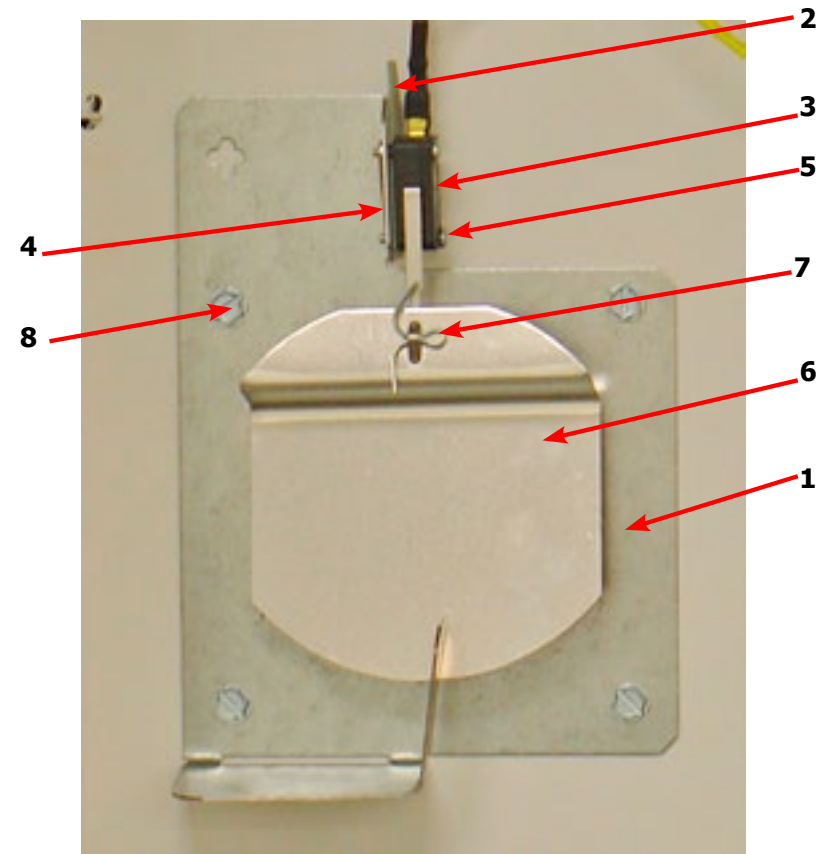



Key	Description	T-30	T-50	T80	QTY
*	Air Flow switch Assy	9801-095-001	9801-098-001	9801-098-001	1
1	Bracket-Airflow switch	9029-174-001	9029-200-001	9029-200-001	1
2	Shield-Switch	9550-169-003	9550-169-003	9550-169-003	1
3	Switch-Micro	9539-461-009	9539-461-009	9539-461-009	1
4	Nut-Twin, 4-40	8640-401-001	8640-401-001	8640-401-001	1
5	Screw-.625, 4-40	9545-020-001	9545-020-001	9545-020-001	2
6	Actuator-Air Flow Switch	9008-007-001	9008-007-001	9008-007-001	1
7	Pin-Cotter, .09375x.75	9451-169-002	9451-169-002	9451-169-002	1
8	Screw, 10Bx1/4	9545-008-001			4
8	Screw, 10Bx1/4		9545-008-001	9545-008-001	5

Electrical Box / Ignition Control

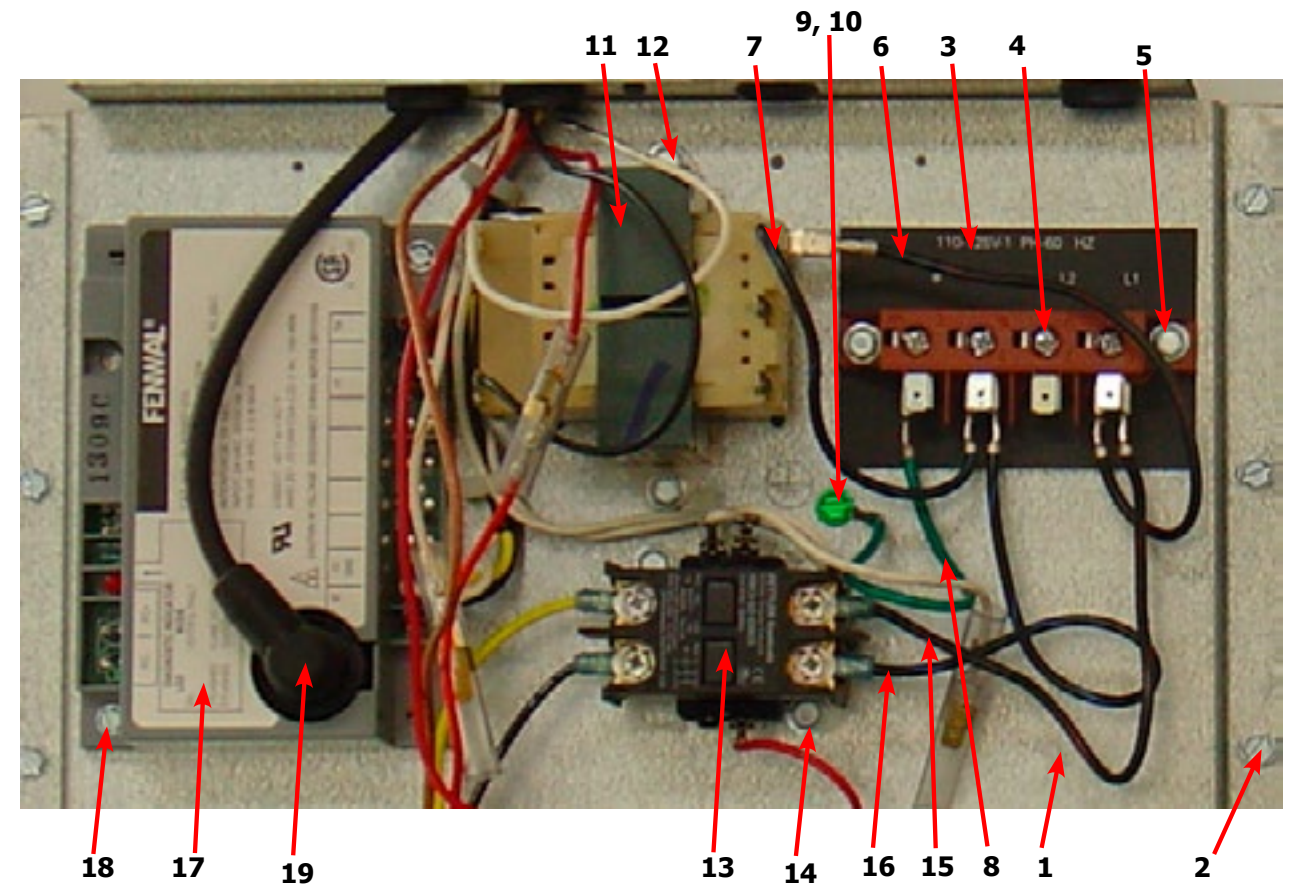

Key	Description	T-30	T-50	T80	QTY
1	Wrapper-Control Box	9636-200-001	9636-200-001	9636-200-001	1
2	Screw, 5/16-10AB-3/8	9545-008-001	9545-008-001	9545-008-001	6
*	Cover-Control Box	9074-346-001	9074-346-001	9074-346-001	1
*	Screw, 5/16-10AB-3/8	9545-008-024	9545-008-024	9545-008-024	1
3	Strip-Marker, Terminal	9558-029-005	9558-029-005	9558-029-005	1
4	Terminal Block Assy-Power, 4Pole	9897-035-001	9897-035-001	9897-035-001	1
5	Screw, 5/16-10AB-3/8	9545-008-024	9545-008-024	9545-008-024	2
6	Wire assy-Blk/Red, 6 1/2"	8220-001-230	8220-001-230	8220-001-230	1
7	Wire assy-Blk/Blu, 6 1/2"	8220-001-231	8220-001-231	8220-001-231	1
8	Wire Assy, GRN, 7"	8220-001-478	8220-001-478	8220-001-478	1
9	Screw- 10-32TTx1/2 GRN	9545-008-027	9545-008-027	9545-008-027	1
10	Lockwasher, External tooth	8641-582-006	8641-582-006	8641-582-006	1
11	Transformer, w/Circuit braker	8711-007-002	8711-007-002	8711-007-002	1
12	Screw, 5/16-10AB-3/8	9545-008-024	9545-008-024	9545-008-024	2
13	Relay-Motor, 30Amp, 24VAC	5192-299-002	5192-299-002	5192-299-002	1
14	Screw, 5/16-10AB-3/8	9545-008-024	9545-008-024	9545-008-024	2
15	Wire assy-Blk/Red, 9"	8220-146-001	8220-146-001	8220-146-001	1
16	Wire assy-Blk/Blu, 9"	8220-146-002	8220-146-002	8220-146-002	1
17	Control Assy, Ignition (Module)	9857-182-001	9857-182-001	9857-182-001	1
18	Screw-8Bx3/4"	9545-045-007	9545-045-007	9545-045-007	2
*	Harness, Ignition Module	9627-867-003	9627-867-003	9627-867-003	1
19	Wire Assy- High Voltage Lead	9631-403-009	9631-403-009	9631-403-009	1

DN0030, 50EC_-74EB, 240V/3 Phase/60HZ 24KW

Key	Description	T-30	T-50	T80	QTY
	Power-Block, 3 Pole	9897-037-001	9897-037-001		1
	Power-Block, 1 Pole	9897-038-001	9897-038-001		1
	Terminal-Lug, Solderless	8652-134-002	8652-134-002		1
	Scrraw-10-32TT x1/2 GRN	9545-008-027	9545-008-027		1
	Wire Assy-BLK #13 8"	8220-057-016	8220-057-016		3
	Wire Assy-BLK/RED, 12"	8220-151-001	8220-151-001		1
	Wire Assy-BLK/BLU, #12, 12"	8220-151-002	8220-151-002		1
	Wire Assy-BLK, #35, 9"	8220-078-008	8220-078-008		2
	Wire Assy, WHT, 8"	8220-057-019	8220-057-019		1
	Wire Assy-BLK/RED, #9, 9"	8220-146-001	8220-146-001		1
	Wire Assy-BLK/BLU, #21, 9"	8220-146-002	8220-146-002		1
	Transformer 120/24VAC	8711-007-002	8711-007-002		1
	Relay, R1-Motor Run	5192-299-002	5192-299-002		1
	Relay, R2-Heat relay	5192-285-004	5192-285-004		1
	Varistor-Coil Suppressor	9733-003-001	9733-003-001		1
	Relay, Elements	5192-296-001	5192-296-001		1
	Wire Assy-BLK, #33, 8"	8220-057-015	8220-057-015		6
	Curcit Breaker, 3-Pole, 35AMP	5198-213-001	5198-213-001		2
	Wire Assy-BLK, #34, 36"	8220-061-008	8220-061-008		1
	Wire Assy-BLK, #34, 48"	8220-061-010	8220-061-010		1
	Heating Elements, 12KW, 208V	9870-096-006	9870-096-006		2
	Jumper-Formed	9295-004-001	9295-004-001		2
	Jumper-Formed	9295-005-001	9295-005-001		4

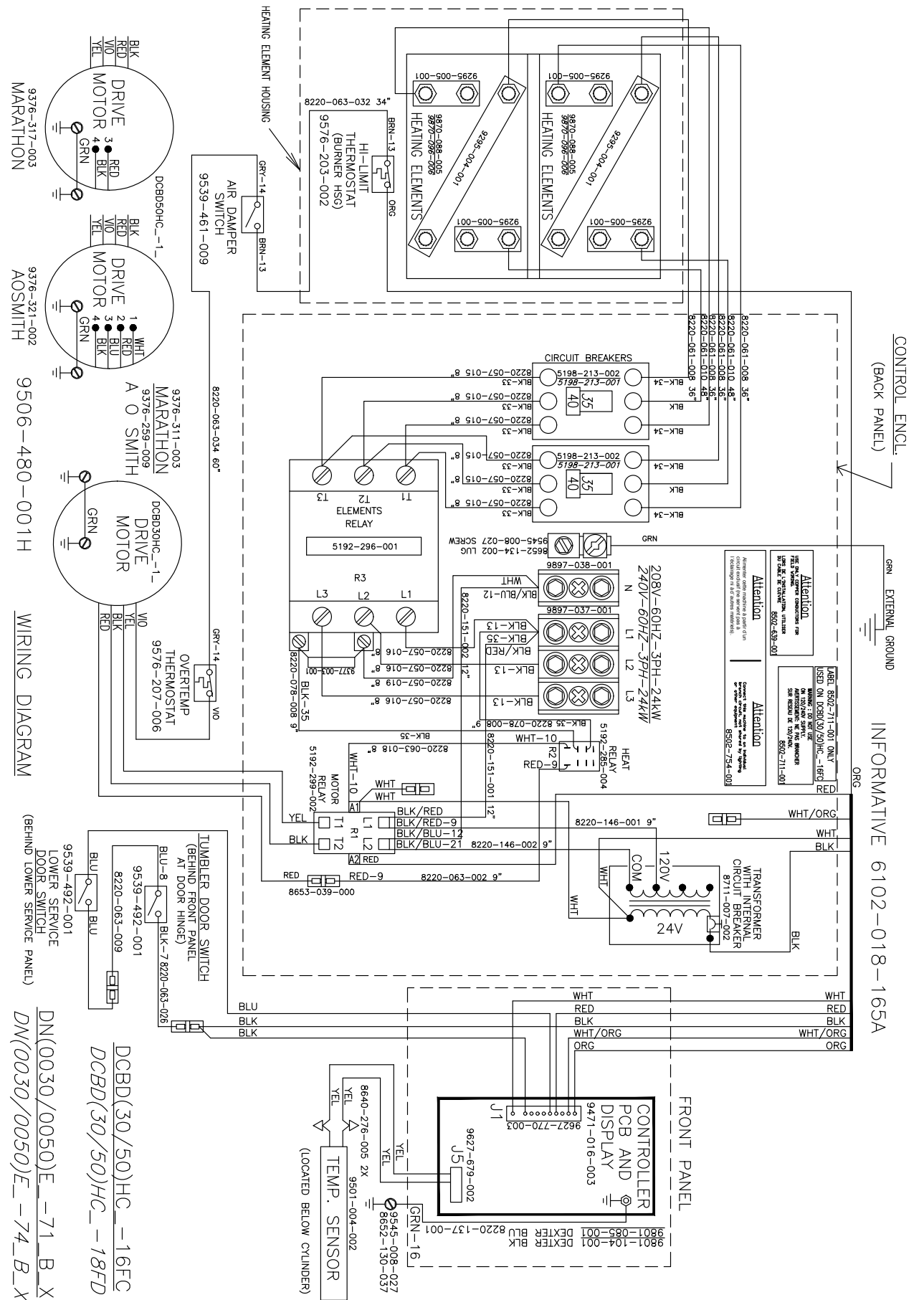

DN0080EC_-73EB, 208V/3 Phase/60HZ 34.6KW

Key	Description	T-30	T-50	T80	QTY
	Power-Block, 3 Pole			9897-037-001	1
	Power-Block, 1 Pole			9897-038-001	1
	Terminal marker			? 9558-032-001	1
	Terminal-Lug, Solderless			8652-134-002	1
	Scrwew-10-32TT x1/2 GRN			9545-008-027	1
	Wire Assy-BLK 9"			8220-078-008	1
	Wire Assy-BLU #2, 11"			8220-064-061	1
	Wire Assy-BLK 8"			8220-057-017	3
	Wire Assy-WHT 8"			8220-057-019	
	Transformer 250/24VAC			8711-008-002	1
	Wire Assy-BLK/RED, 12"			8220-151-001	1
	Wire Assy-BLK/BLU, #12, 12"			8220-151-002	1
	Wire Assy-BLK/RED, 9"			8220-146-001	1
	Wire Assy-BLK/BLU, 9"			8220-146-002	1
	Relay, R1-Motor Run			5192-299-002	1
	Wire Assy-WHT, 10"			8220-063-018	1
	Relay, R2-Heat relay			5192-285-004	1
	Wire Assy-BLK, 9"			8220-078-008	1
	Varistor-Coil Suppressor			9733-003-001	1
	Relay, Elements			5192-294-001	1
	Wire Assy-BLK, #33, 8"			8220-057-015	6
	Curcit Breaker, 3-Pole, 25AMP			5198-213-005	2
	Wire Assy-BLK, #34, 36"			8220-061-008	6
	Wire Assy-BLK, #34, 48"			8220-061-010	2
	Heating Elements, 17.3KW, 208V			9870-088-006	2
	Jumper-Formed			9295-005-001	4
	Jumper-Formed			9295-004-001	2

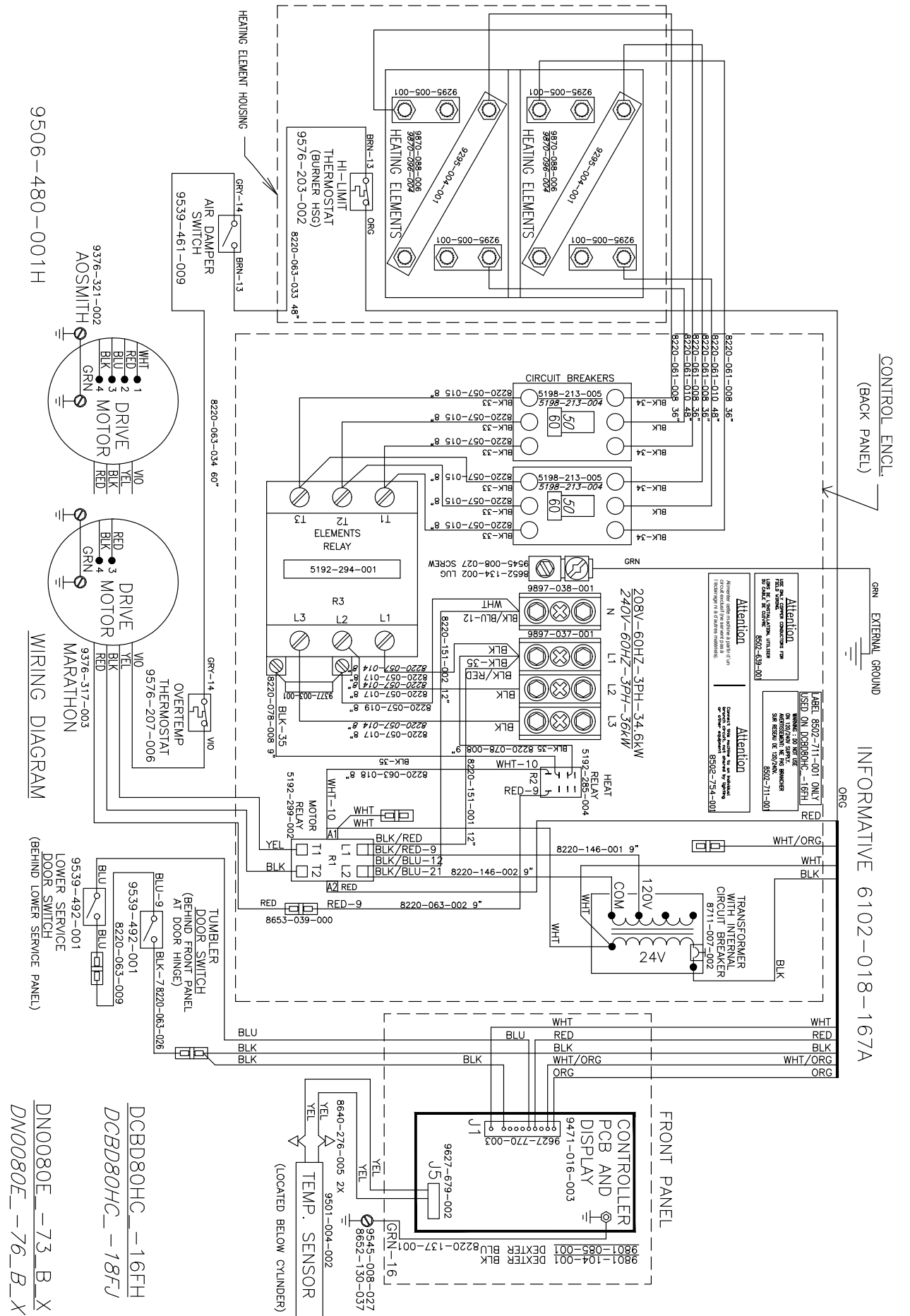

DN0030.50.80NC_-39 230VAC 1 PH 50Hz

Key	Description	T-30	T-50	T80	QTY
	Motor	9376-311-004	9376-317-004	9376-317-004	1
	Pulley	9453-169-009	9435-169-014	9453-169-009	1
	Strip Terminal Marker	9558-029-004	9558-029-004	9558-029-004	1
	Wiring Label-Schematic/Diagram	9506-496-001	9506-496-001	9506-496-001	1
	Switch Assembly-Air flow	9801-095-002			
	Bracket-Airflow switch	9029-174-002			
	Switch Micro	9539-461-009			
	Orifice Main Burner, #32	9425-069-009			2
	Orifice Main Burner, #32		9425-069-009		3
	Orifice Main Burner, #30			9425-069-002	4
	LP Kit	9732-102-019	9732-102-021	9732-102-022	1
	Overlay-Trim Lower door	9435-016-004	9435-016-005	9435-016-005	1

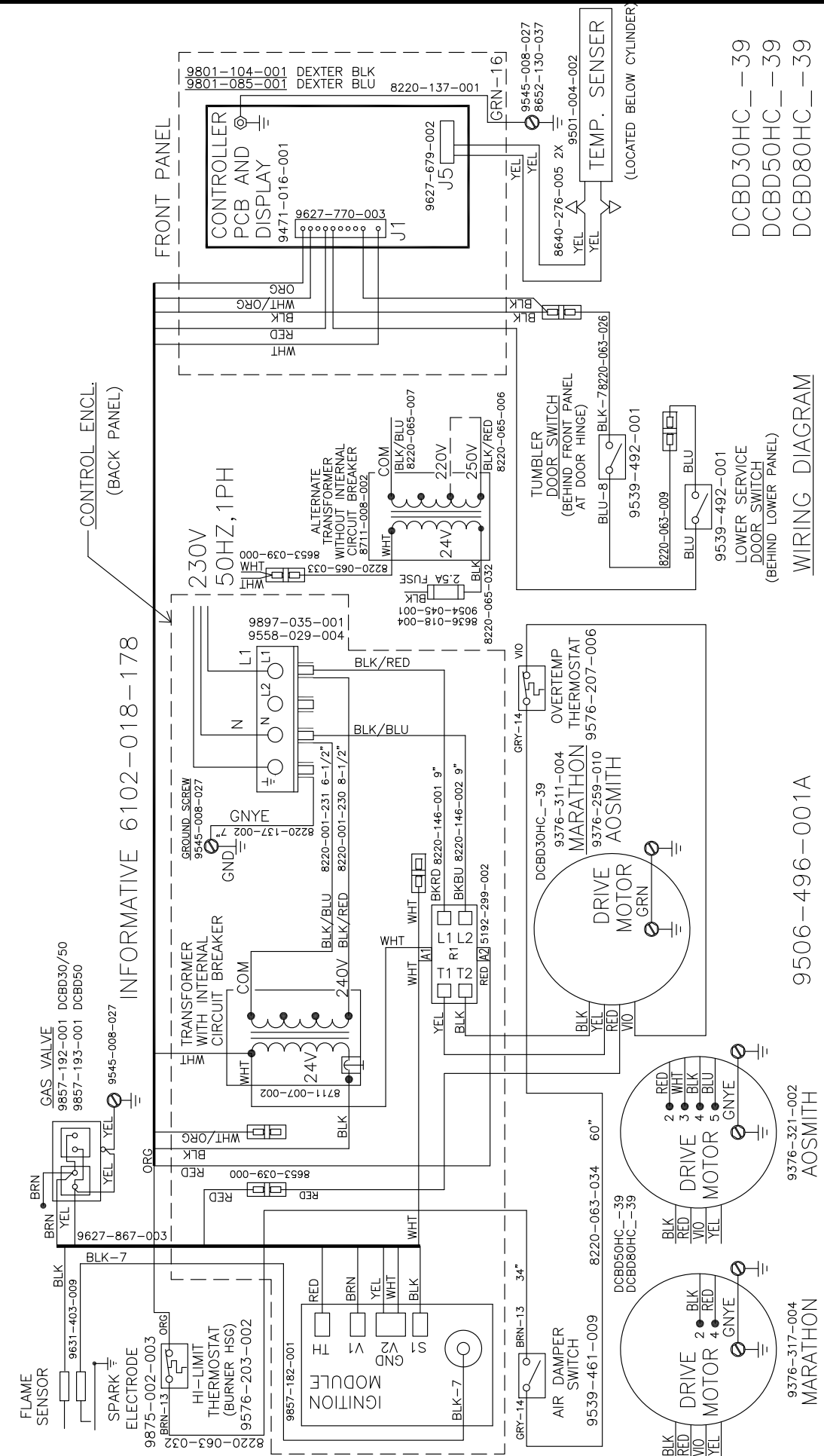

DCBD30HC_-39
DCBD50HC_-39
DCBD80HC_-39

9539-492-001
LOWER SERVICE DOOR SWITCH (BEHIND LOWER PANEL)

9506-496-001A

9376-321-002
AOSMITH

9376-317-004
MARATHON

Parts for 50hz Dryer -59

Key	Description	T-30	T-50	T80	QTY
*	Motor	9376-311-004	9376-317-004	9376-317-004	1
*	Pulley	9453-169-009	9435-169-014	9453-169-009	1
*	Strip Terminal Marker	9558-029-004	9558-029-004	9558-029-004	1
*	Filter, EMI Line	9183-030-001	9183-030-001	9183-030-001	1
*	Transformer, Control (Before Serial)	8711-008-002	8711-008-002	8711-008-002	1
*	Transformer (After Serial)	8711-004-004	8711-004-004	8711-004-004	1
*	Holder, Fuse	9054-045-001	9045-045-001	9045-045-001	1
*	Fuse 2.5 Amp	8636-018-004	8636-018-004	8636-018-004	1
*	Motor, Marathon 50Hz	9376-311-004	9376-317-004	9376-317-004	1
*	Pulley, Motor	9453-169-009	9453-169-014	9453-169-009	1
*	Wiring Label-Schematic/Diagram (Before serial)	9506-483-001	9506-483-001	9506-483-001	1
*	Wiring Label (After Serial #)	9506-958-001	9506-958-001	9506-958-001	1
*	Orifice Main Burner, #30 Natural	9425-069-009	9425-069-009	9425-069-002	4
*	LP Kit	TBR	TBR	TBR	1
*	Gas Valve Assembly	9857-132-004	9857-132-004	9857-132-004	1
*	Kit-Honeywell VR86 Flange Kit 3/4	9732-162-002	9732-162-002	9732-162-002	2
*	Adaptor Assembly Gas Valve	9791-001-001	9791-001-001	9791-001-001	1
*	Manual, Operators (Before Serial #)	8514-213-001	8514-213-001	8514-213-001	1
*	Manual, Operators (After Serial #)	8514-311-001	8514-311-001	8514-311-001	1
*	Hot Surface Warning Label	8502-748-017	8502-748-017	8502-748-017	1
*	Do Not Enter Warning Label	8502-748-001	8502-748-001	8502-748-001	1
*	Explosive Material Warning Label	8502-748-006	8502-748-006	8502-748-006	1
*	Flammable Material Warning Label	8502-748-007	8502-748-007	8502-748-007	1
*	Do Not Operate w/ Guards Removed Label	8502-748-003	8502-748-003	8502-748-003	3
*	Frame/Chassis Ground Label	8502-748-014	8502-748-014	8502-748-014	1
*	Do Not Operate w/ Guards Removed Label	8502-748-004	8502-748-004	8502-748-004	1
*	Electrical Shock Warning Label	8502-748-005	8502-748-005	8502-748-005	1
*	Lockout Warning Label	8502-748-008	8502-748-008	8502-748-008	1
*	Read Operators Manal Label	8502-748-009	8502-748-009	8502-748-009	2
*	PE Mark (Ext. Protective Ground) Label	8502-748-015	8502-748-015	8502-748-015	1

