



DEXTER[®]
LAUNDRY

**USE THE BLUE TABS LOCATED ON THE
RIGHT AND LEFT SIDES OF THE FOLLOWING
DOCUMENT TO ADVANCE TO EACH SECTION.**

C-Series OPL Accessories

WN0650XA-12EV	208-240 volts	60hz	Single Phase or Three Phase
WN0750XA-12EV	208-240 volts	60hz.	Single Phase or Three Phase
WN0950XA-12EV	208-240 volts	60hz	Single Phase or Three Phase
WN1450XA-12EV	208-240 volts	60 hz	Single Phase or Three Phase

Key	Description	T650	T750	T950	T1450	QTY
*	Hose, Water Supply 3/8" I.D. x 48"	9990-027-011				2
*	Hose, Water Supply 5/8" I.D. x 48"		9990-027-013	9990-027-013		2
	Hose, Water Supply 5/8" I.D. x 48"				9990-027-013	4
*	Washer, Inlet Hose (furnished)	8641-242-000	8641-242-000	8641-242-000	8641-242-000	2
*	Strainer, Inlet Hose (furnished)	9565-003-001	9565-003-001	9565-003-001	9565-003-001	2
*	Bevel Washer for 5/8" bolt used in installations using angle iron bases					
*	Bevel Washer for 3/4" bolt used in installations using angle iron bases		8641-586-003	8641-586-003	8641-586-003	4
*	Sealing compound RTV-45	8538-151-002	8538-151-002	8538-151-002	8538-151-002	1
*	Flow Restrictors (in dispenser)	9475-002-002	9475-002-002	9475-002-003	9475-002-003	2
*	Battery (used on Control PCB)	8612-001-001	8612-001-001	8612-001-001	8612-001-001	1
*	VFD Filter options (1 phase) 120v					1
*	VFD Filter options (3 phase)					1
*	VFD Filter options (1 phase)					1
*	Puller for pushing cylinder out of bearings must be purchased from local sources.					1
*	Clamps to hold tub front to outer tub when installing tub front	Vise Grip #11R	Vise Grip #11R	Vise Grip #11R	Vise Grip #11R	1
*	OPL Bearing & Seal Kit	9732-219-007	9732-219-007	9732-219-007		1
*	OPL Op CD with OS2 Platform for V Series Washer Controls	9504-016-001	9504-016-001	9504-016-001	9504-016-001	1
	Palm Pilot Zire 31	9150-035-001	9150-035-001	9150-035-001	9150-035-001	1
	Key Service Lock (6324)	6292-006-007	6292-006-007	6292-006-007	6292-006-007	1
	Key, Program (N561)	6292-006-013	6292-006-013	6292-006-013	6292-006-013	1
	USB Thumb Drive W/Ooperator Booklets all sizes	9150-045-002	9150-045-002	9150-045-002	9150-045-002	
*	Mode Light Support	9635-022-001	9635-022-001	9635-022-001	9635-022-001	1

Kits, Assemblies, & Common Parts

Loading Door & Door Lock Components	Part Number
Door Glass Gasket (Large Door)	9206-431-001
Door Glass Gasket (Standard Door)	9206-419-001
Door Handle Only (Large)	9244-091-001
Door Close Switch	9539-492-001
Door Lock Gear Motor Assembly	9922-015-001
Kit - Door Latching Assy. & Cam (replaces original Door Latching Assembly)	9732-347-001
Kit - Door Cam Replacement	9732-346-002
Kit - Locking Pawl Replacement	9732-346-001
Kit - Door Gasket Expander Kit (Small)	9732-139-001
Kit - Door Gasket Expander Kit (Large)	9732-139-002
Electrical Components	Part Number
Transformer, Main	8711-004-001
Transformer, Control	8711-009-004
Main Control Board	9473-010-001
Kit-Replacement, Pressure Sensor (Only)	9732-315-001
VFD & Breaking Resistors Components	Part Number
Breaking Resistor 200 Ohms	9483-004-002
Breaking Resistor 160 Ohms	9483-004-003
Delta E Drive Display	9150-044-001
MS 300 VFD Display	9150-058-001
Data Cable (56")	9806-015-003
Drain & Water Valve Components	Part Number
Kit - 3" Drain Valve Seal Replacement	9732-327-001
Drain Valve 3"	9379-202-001
Water Valve (Dual)	9379-183-012
Water Valve (Single Mueller)	9379-194-001
Diaphragm (Dual)	9118-049-003
Diaphragm (Single Mueller)	9118-055-001
Cabinet Components	Part Number
Front Panel Screw	9545-008-014
Front Panel Finisher Washer	8641-585-001
Front Panel Spring Nut	8640-399-008
Top Soap Box Screw (Regular Chassis Only)	9545-008-012
Top Soap Box Spring Nut (Regular Chassis Only)	8640-399-007
5/16 Hex Screw, Common	9545-008-026
Top Lock Key #6324	9306-025-001
Cylinder Plug (1.5" Plastic)	9456-041-007



Section 8: Parts Data

WN0650XA-12EV	208-240 volts	60hz	Single Phase or Three Phase
WN0750XA-12EV	208-240 volts	60hz.	Single Phase or Three Phase
WN0950XA-12EV	208-240 volts	60hz	Single Phase or Three Phase
WN1450XA-12EV	208-240 volts	60 hz	Single Phase or Three Phase

Wiring Harness Part # by Model

Key	Description	T650	T750	T950	T1450	QTY
*	Wiring Harness (Add Bleach Lite assy included)	9794-001-001	9794-001-001	9794-001-001	9794-001-001	1
*	Wiring Harness, Door Lock	9627-791-005	9627-791-005	9627-791-005	9627-791-005	1
*						
*	Wiring Harness, Drain,Thermo,DoorSol	9627-796-002	9627-796-002	9627-796-002	9627-796-002	1
*	Data Cable	9806-015-001	9806-015-001	9806-015-001	9806-015-003	1
*	Wiring Harness P20/P21	9627-793-001	9627-793-001	9627-793-001	9627-793-001	1
*	Wiring Harness P8/P16	9627-794-001	9627-794-001	9627-794-001	9627-794-001	1
*	Wiring Harness WaterValve/P19	9627-795-004	9627-795-004	9627-795-004	9627-795-004	1
*	Wiring Harness LED PCB	9627-797-001	9627-797-001	9627-797-001	9627-797-001	1
*	Wiring Harness P5/pressure	9627-806-001	9627-807-001	9627-807-001	9627-900-001	1
	Wiring Harness, P23/P15	9627-798-001	9627-798-001	9627-798-001	9627-798-001	
	Wiring Harness, P10	9627-799-001	9627-799-001	9627-799-002	9627-799-002	
*	Wiring Assembly Yel. 32"			8220-064-023		2
*	Wiring Assembly Yel. 64"				8220-064-040	2
*	Wiring Assembly Red 23" #8	8220-063-028	8220-063-028			1
*	Wiring Assembly Red 41"				8220-062-032	2
*	Wiring Assembly Vio. 24"				8220-118-001	2
*	Wiring Assembly Wht/Brn 8"				8220-108-007	1
*	Wiring Assembly Jumper Yel	8220-123-001	8220-123-001	8220-128-001	8220-128-001	1
*	Wire Red Yellow 8"				8220-108-008	1
*	Wire Yellow Jumper (water valve)				8220-119-002	1
*	80lb Washer Dispenser Label				8502-687-001	1
*	Wiring Assembly Red 28" #24	8220-062-025	8220-062-025	8220-062-025		2
*	Wiring Assembly Blk. 17"			8220-062-028	8220-062-028	1
*	Wiring Assembly Red 17"			8220-062-027	8220-062-027	1
*	Wiring Assembly Jumper BLK.	8220-117-002	8220-117-002	8220-117-002	8220-117-003	2
*	Wiring Assembly Red 7" #36	9631-381-018	9631-381-018	9631-381-018	9631-381-018	1
*	Wiring Assembly Blu/Wht	8220-090-009	8220-090-009	8220-090-009	8220-090-009	1
*	Wiring Assembly Blk/Blu	8220-001-231	8220-001-231	8220-001-231	8220-001-231	1
*	Wire Assembly Green 7"					1
*	Wire Assembly BLK. 23" #8	8220-063-029	8220-063-029			
*	Harness Power Terminal Block	9627-747-003	9627-747-003	9627-747-002	9627-747-002	1

Cabinet and Front Panel Group Part # by Model Large Door

Key	Description	T650	T750	T950	T1450	QTY
1	Panel, Side (Left or Right) - stainless		9454-812-001			2
1	Panel, Side (Left or Right) - stainless	9454-914-001		9454-839-001	9454-836-001	2
*	Bolt-1/4-20x1/2 (side panel Front to Rear)			9545-018-013	9545-018-013	8
	Nut 1/4-20UNC (side panel)			8640-414-006	8640-414-006	8
	Strap Assy (Side to base)	9966-012-001	9966-013-001			2
	Strap Assy (Side to base)			9966-012-001	9966-012-001	4
*	Shim (side panel)	9552-038-001	9552-041-001	9552-039-001	9552-044-001	2
*	Nut, Hex 1/4-20 UNC (for strap assembly)	8640-414-006	8640-414-006			6
*	Nut, Hex 1/4-20 UNC			8640-414-006	8640-414-006	8
2	Bracket, Side Panel under front panel	9046-094-001	9046-085-001	9046-085-001	9046-086-001	1
*	Screw #10Bx1/2 side panel brkt	9545-008-026	9545-008-026	9545-008-026	9545-008-026	1
*	Nut 1/4-20 UNC side panel brkt	8640-414-003	8640-414-006	8640-414-006	8640-414-006	1
•	Nut, Hex			8640-413-002	8640-414-006	2
*	Screw			9545-008-024	9545-008-026	2
3	Panel Assy, Front	9454-913-002	9454-810-002	9989-617-003	9989-619-003	1
4	Band, Edge Protector	9578-092-005	9578-092-005	9578-092-005	9578-092-005	1
*	Bumper Loading Door	9051-055-001	9051-055-001	9051-055-001	9051-055-001	1
*	Nut, 1/4 x 20 for bumper	8640-414-006	8640-414-006	8640-414-006	8640-414-006	1
*	Screw, Hex- To Control Panel	9545-008-014	9545-008-014	9545-008-024	9545-008-024	2
*	Nut, Spring- To Control Panel 10/32	8640-442-001	8640-442-001	8640-442-001	8640-442-001	2
5	Screw, Flat Head- Front to Sides	9545-008-014	9545-008-014	9545-008-014	9545-008-014	2
6	Washer, Finish	8641-585-001	8641-585-001	8641-585-001	8641-585-001	2
*	Nut, Spring-To Front Panel	8640-442-001	8640-442-001	8640-442-001	8640-442-001	2
7	Label, Door Opening (Black)	8502-757-001	8502-757-001	8502-757-001	8502-757-001	1
8	Panel, Control (Mounts Nameplate)	9989-479-001	9989-480-001	9989-480-001	9989-530-001	1
*	Screw, Control Panel to Sides	9545-008-026	9545-008-026	9545-008-026	9545-008-026	4
9	Nameplate Decal, Control Black	9412-236-001	9412-223-001	9412-225-001	9412-230-001	
10	Panel Top	9454-912-001	9454-743-001	9454-736-001		1
11A	Panel Top Front				9454-850-001	1
11B	Panel Top Rear				9454-851-001	1
12	Lock, Top (w/Key)	8650-012-003				1
12	Lock, Top (w/Key)		8650-012-003	8650-012-003	8650-012-003	2
*	Lock Spacer	9538-189-001	9538-189-001	9538-189-001	9538-189-001	*
13	Door, Lower Service, Includes Handle	9960-286-002	9960-286-004	9960-286-004	9960-286-005	1
14	Handle (bumper guard)	9244-086-002	9244-086-003	9244-086-003	9244-086-004	1
*	Rivet Blind 3/16" Alum	9491-009-003	9491-009-003	9491-009-003	9491-009-003	4
*	Screw	9545-045-010	9545-045-010	9545-045-010	9545-045-010	4

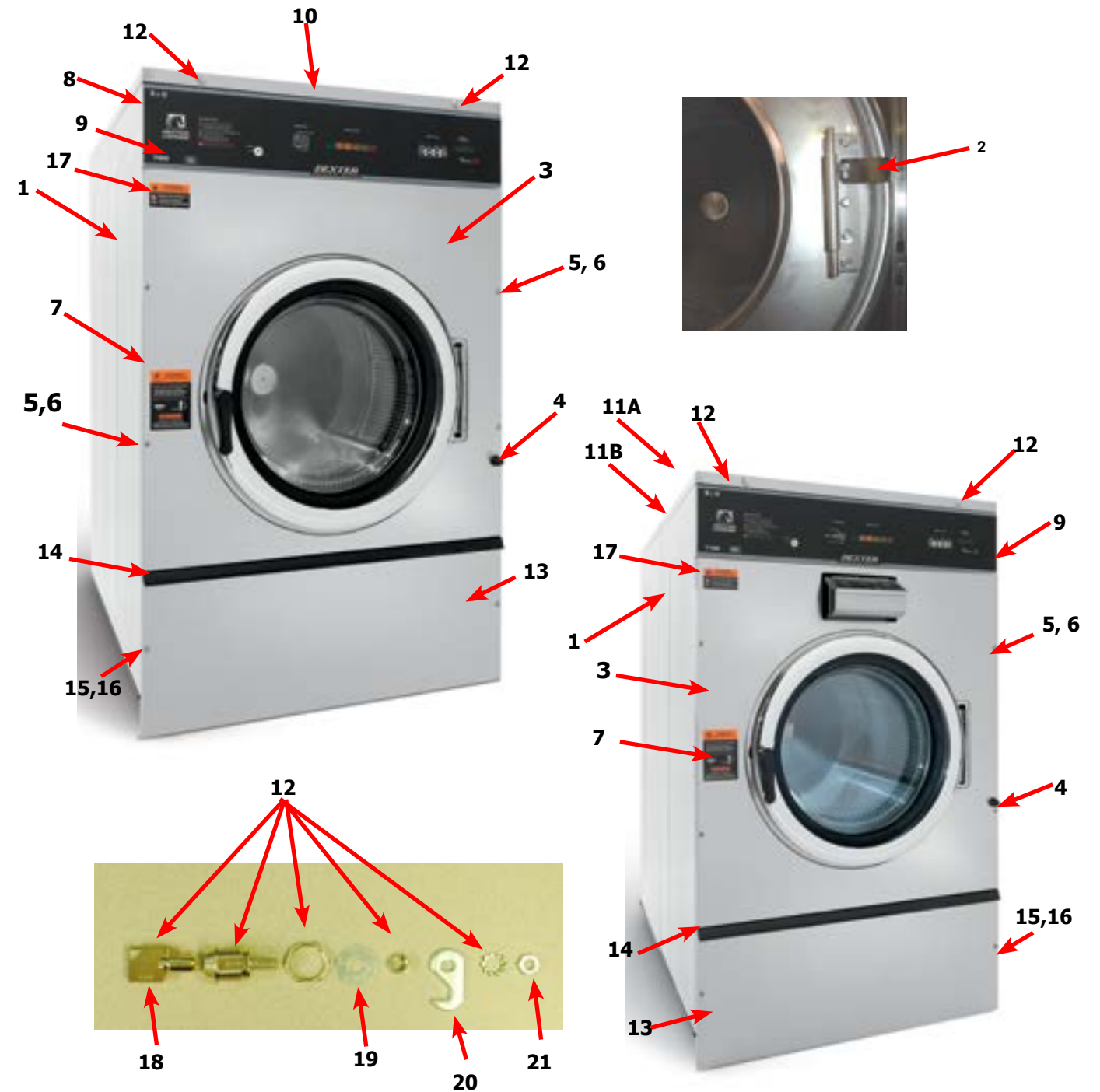

Key	Description	T650	T750	T950	T1450	QTY
15	Screw Mtg., Flat Head 10Bx1 3/4	9545-008-014	9545-008-014	9545-008-014	9545-008-014	2
16	Washer, Finish	8641-585-001	8641-585-001	8641-585-001	8641-585-001	2
*	Nut, Spring	8640-399-008	8640-399-008	8640-399-008	8640-399-008	2
17	Label-Risk of injury (Black)	8507-759-001	8507-759-001	8507-759-001	8507-759-001	1
18	Key, Top- # 6324	6292-006-007	6292-006-007	6292-006-007	6292-006-007	
19	Washer Flat 5/16	8641-581-008	8641-581-008	8641-581-008	8641-581-008	2
20	Cam, Lock-Top	9095-049-001	9095-049-001	9095-049-001	9095-049-001	2
21	Nut, 9/32 - 28 Hex	8640-426-001	8640-426-001	8640-426-001	8640-426-001	2

Cabinet and Front Panel Group Part # by Model Front Soap Dish

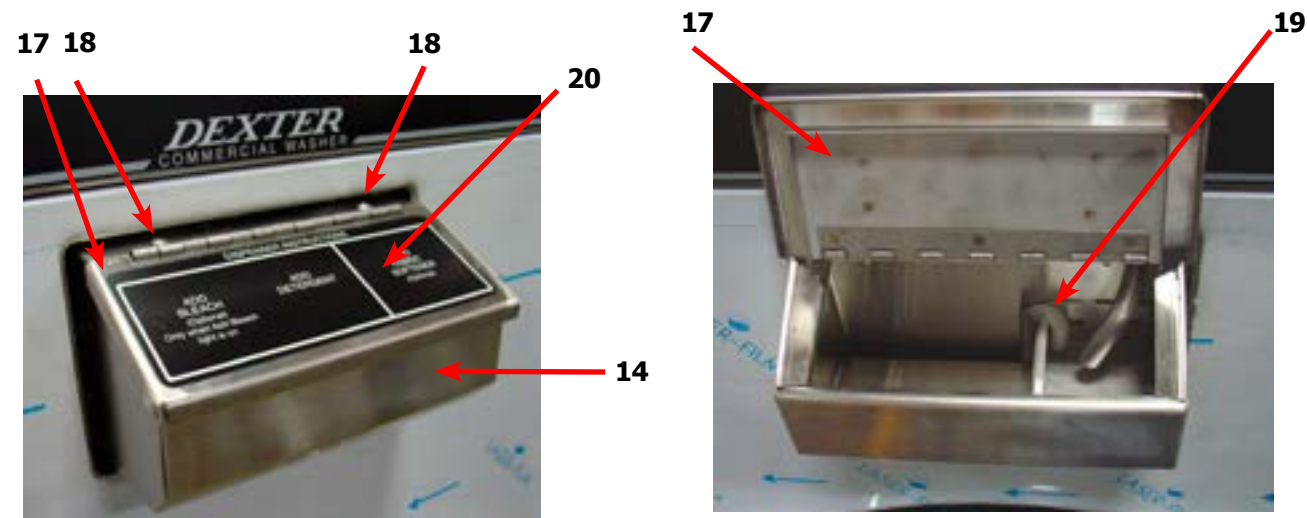
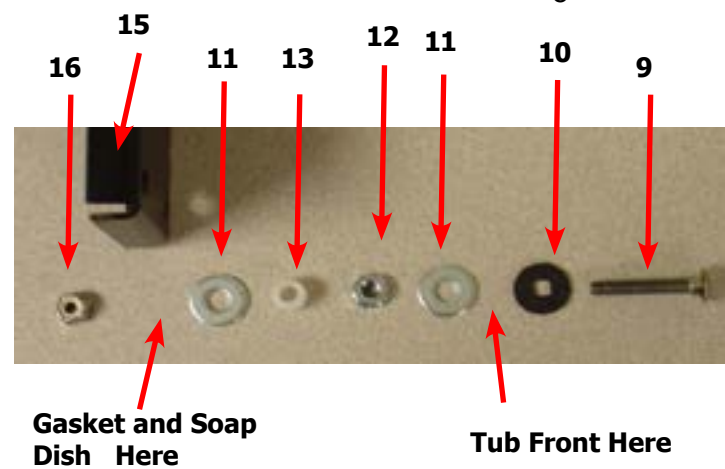
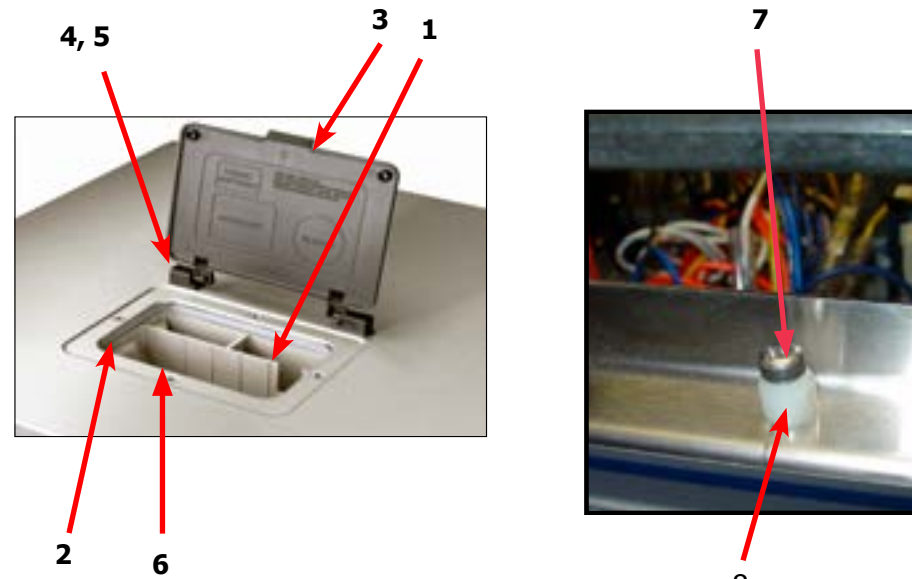

Top Mount Detergent Dispenser

Key	Description	T650	T750	T950	T1450	QTY
1	Dispenser Soap	9122-005-004	9122-005-004	9122-005-004		1
2	Gasket Despinsor	9206-416-001	9206-416-001	9206-416-001		1
*	Hose, Despinsor to tub	9242-450-003	9242-450-001	9242-450-001		1
*	Clamp	8654-117-008	8654-117-008	8654-117-008		2
*	Nut, Spring ss	8640-399-007	8640-399-007	8640-399-007		4
*	Flow restrictors	9475-002-002	9475-002-002	9475-002-002		2
*	Flow restrictors Optional (Smaller)	9475-002-003	9475-002-003	9475-002-003		2
3	Door, Dispenser	9108-095-005	9108-095-005	9108-095-005		1
4	Pin, Plain	9451-191-001	9451-191-001	9451-191-001		2
*	Post, Door Mounting	9467-025-001	9467-025-001	9467-025-001		2
6	Screw- 8B x 1/2	9545-045-002	9545-045-002	9545-045-002		4
	Screw, SS Dispenser, 10B x 1	9545-008-012	9545-008-012	9545-008-012		4
*	Washer Flat 5/16	8641-581-008	8641-581-008	8641-581-008	8641-581-008	1
7	Screw, Locator	9545-008-023	9545-008-023	9545-008-023	9545-008-023	1
8	Plastic Sleeve, Locator	9355-001-001	9355-001-001	9355-001-001	9355-001-001	1
*	Catch, Top Panel	9086-017-001	9086-017-001	9086-017-001	9086-017-001	2
	Lock, Top (w/Key)	8650-012-003				1
*	Lock, Top (w/Key)		8650-012-003	8650-012-003	8650-012-003	2

Front Mount Detergent Dispenser

Key	Description	T650	T750	T950	T1450	QTY
9	Bolt, #10-32 x 1 1/4"SS				9545-012-026	6
10	Special Washer, Rubber				8641-222-000	6
*	Tub Front					1
11	Washer-Flat, 1/4				8641-581-018	12
12	Nut, #10-32UNF				8640-413-002	6
13	Spacer Plastic #10x1/2				9538-157-019	6
14	Soap Dispenser (no lid)				9807-087-001	1
*	Det. Dispenser Mtg Gasket to Tub frnt				9206-425-001	1
15	Bracket Soap box mounting				9029-122-002	1
16	Nut Hex Elasticstop #10-32 SS mtg dispenser				8640-413-006	6
17	Lid Assembly dispenser				9987-104-001	1
18	Lid screws #10-32x1/2 SS				9545-012-017	2
19	Softner siphon tube (plastic)				9574-252-002	1
*	Flow restrictors				9475-002-003	AR
20	Washer Dispenser Label Black				8502-756-001	1
*	Kit-Soap Dish, Replacement (Large Door)				9732-290-001	
*	Kit to Remove Front Soap Dish				9732-353-004	1

Chemical Injection Only No Front Detergent Dispenser

Key	Description	T650	T750	T950	T1450	QTY
*	Front Panel Assy.				9989-669-007	1
*	SS Braket, Cover Plate				9029-122-003	1
*	Kit to Add Front Soap Dish				9732-353-002	1

Rear View Access Part # by Model

Key	Description	T650	T750	T950	T1450	QTY
1	Drive Motor, 3 Phase (Inverter duty)	9376-319-001	9376-329-001	9376-329-001	9376-328-001	1
2	Rod, Motor Mtg	9497-222-004	9497-222-004	9497-222-004	9497-222-004	1
*	Collar, Shaft (w/set screws) (old)	9076-052-002	9076-052-002		9076-052-002	2
*	Motor Bushing (plastic)	9053-074-002	9053-074-002	9053-074-002	9053-074-002	1
3	New motor bushing support	9053-082-001	9053-082-001	9053-082-001	9053-082-001	2
4	Clamp for motor bushing	8654-117-019	8654-117-019	8654-117-019	8654-117-019	2
5	Pulley, Motor	9453-170-003	9453-179-001	9453-175-002	9453-175-002	1
*	Set Screw 5/16 18-7/8	9545-028-015				
*	Split TaperBushing (motor pulley)		9053-077-001	9053-077-001	9053-077-001	2
*	Screw taper bushing 1/4-20x1		9545-018-024	9545-018-024	9545-018-024	3
6	Bolt, Eye (1/4"-20x1/2")	9545-055-001	9545-055-001	9545-055-001	9545-055-001	1
*	Nut, 1/4 Elastic Stop	8640-414-003	8640-414-003	8640-414-003	8640-414-003	1
*	Link (open end)		9341-046-001	9341-046-001		1
7	Chain (Spring Tension)		9099-012-003	9099-012-003		1
8	Spring, Belt Tension	9534-369-001	9534-369-001	9534-369-001	9534-369-001	1
*	Bracket Belt Tension				9029-206-002	1
*	Lock Washer, Exttooth, 5/16				8641-582-009	
9	Pulley, Driven	9453-173-002	9453-173-002	9453-176-006	9453-176-006	1
*	Tolerance Ring	9487-234-004	9487-234-004			1
*	Screw, 5/8"-11 x 2"	9545-060-004	9545-060-004			1
*	Washer-Flat, 5/8"	8641-582-032	8641-582-032			1
*	Washer-Flat, 5/8"	8641-581-018	8641-581-018			1
10	Bolt, 3/8"-16 x 2"			9545-029-011	9545-029-011	3
11	Washer, 3/8"			8641-582-003	8641-582-003	3
*	Bushing Taperlock (Driven)			9053-078-002	9053-078-002	1
12	Washer-Flat .675x2-1/2x1/4	8641-581-043	8641-581-043	8641-581-043		1
13	Lockwasher-Exttooth, 5/8	8641-582-018	8641-582-018	8641-582-018		1
14	Bolt, 5/8-11x1 1/2	9545-060-001	9545-060-001	9545-060-001		1
12	Washer-Flat, .781x2-1/2x1/4				8641-581-044	1
13	Lockwasher-Exttooth, 3/4				8641-582-020	1
14	Bolt, 3/4-10-1 1/2				9545-057-004	1
15	Drive Belt			9040-079-002	9040-079-006	1
15	Drive Belt	9040-076-005	9040-076-008			2
*	Panel Assy., Back	9989-567-001	9989-455-001	9989-526-001		1
*	Panel Assy., Back, Upper				9454-872-001	1
*	Panel Assy., Back, Lower				9454-873-001	1
*	Screw Panel Mtg.#10Bx1/2"	9545-008-026	9545-008-026			
*	Screw Panel Mtg.#10Bx1/2"			9545-008-026		
*	Screw Panel Mtg.#10Bx1/2"				9545-008-026	15
*	Nut, Spring	8640-399-008	8640-399-008	8640-399-008	8640-399-008	AR
*	Screw, To Base-1/4" x 3/4"	9545-030-002	9545-030-002	9545-030-002	9545-030-002	3

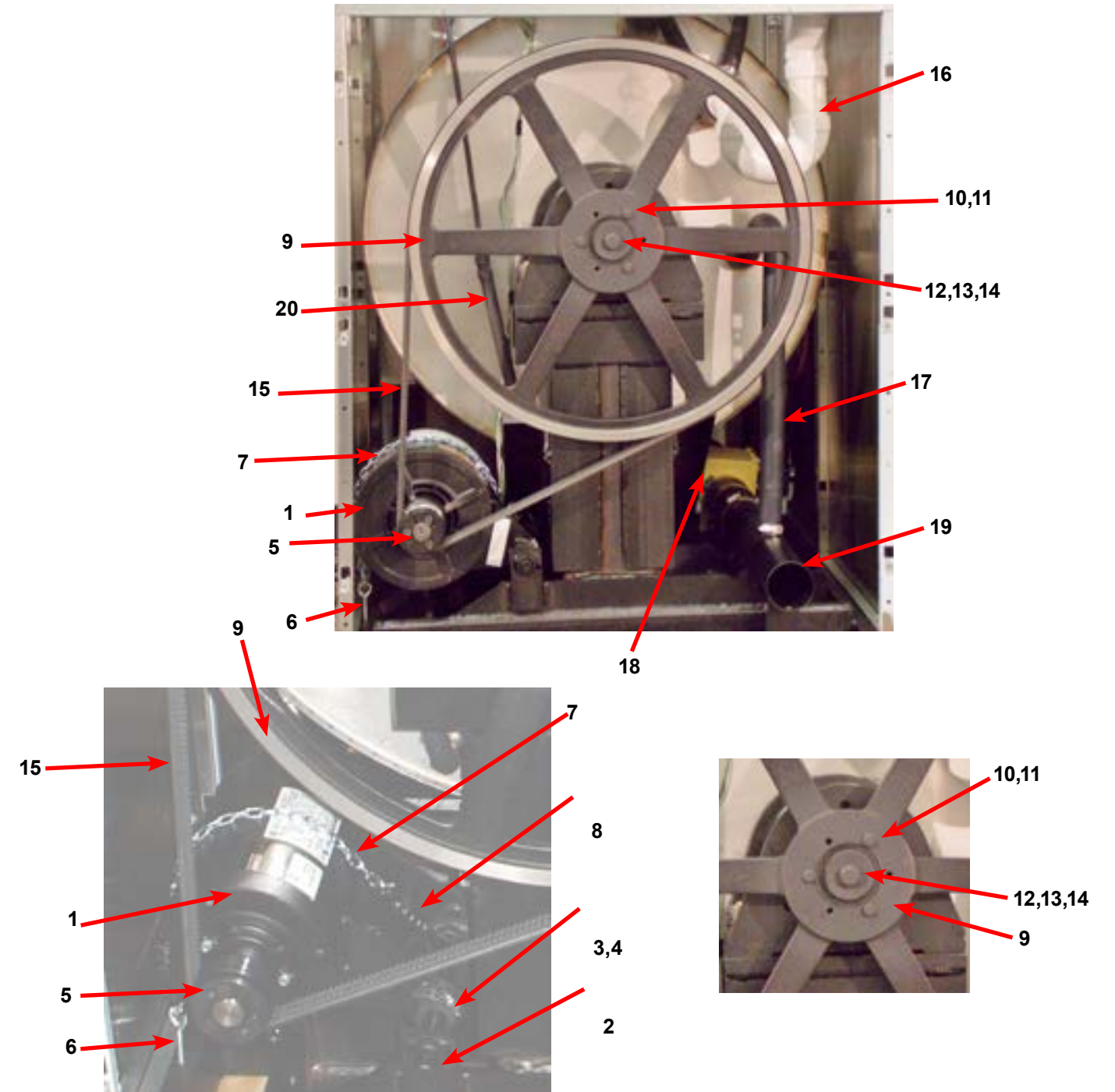

Key	Description	T650	T750	T950	T1450	QTY
16	Injection- tube assy	9883-005-001	9883-005-001	9883-012-001	9883-011-001	1
*	Inlet Cap			0935-135-001		
*	Hose, Injection Tube to Tub	9242-461-001	9242-461-001	9242-461-001	9242-461-001	1
*	Clamp, Injection Hose	8654-117-014	8654-117-014	8654-117-014	8654-117-014	2
17	Hose-Overflow	9242-449-002	9242-449-003	9242-449-003	9242-449-005	1
*	Clamp Hose Over Flow	8654-117-008	8654-117-008	8654-117-008	8654-117-008	2
18	Drain Valve	9379-202-001	9379-202-001	9379-202-001	9379-202-001	1
*	Hose, Drain Valve to Tube	9242-457-001	9242-457-001	9242-457-001	9242-457-001	1
*	Clamp	8654-117-014	8654-117-014	8654-117-014	8654-117-014	2
19	Drain Tube	9915-124-002	9915-124-002	9915-120-004	9915-129-002	1
20	Hose-Pressure Switch	9242-175-002	9242-175-007	9242-175-007	9242-175-004	1

Key	Description	T650	T750	T950	T1450	QTY
*	Channel Assembly Rear	9947-032-001	9947-027-001			
1	Channel, Rear	9081-176-001	9081-168-001	9081-169-002	9081-170-001	1
2	Screw #10Bx1/2	9545-008-026	9545-008-026	9545-008-026	9545-008-026	4
*	Nut, Spring	8640-399-007	8640-399-007	8640-399-007	8640-399-007	4
3	Plug, 7/8"	9456-041-006	9456-041-006	9456-041-006	9456-041-006	1
4	Bushing, 7/8"	9053-067-002	9053-067-002	9053-067-002	9053-067-002	1
5	Braacket-Terminal Block Assy	9029-265-001	9029-265-001	9029-265-001	9029-265-001	1
6	Screw, 10Bx1/2	9545-008-026	9545-008-026	9545-008-026	9545-008-026	4
7	Strip-Terminal marker, Power	9558-025-001	9558-025-001	9558-025-001	9558-025-001	1
8	Terminal Block-Power	9897-033-002	9897-033-002	9897-033-002	9897-033-002	1
*	Screw-6ABx3/4	9545-031-010	9545-031-010	9545-031-010	9545-031-010	2
9	Harness-Power Terminal Block	9627-747-003	9627-747-003	9627-747-003	9627-747-003	1
10	Terrminal Lug, Solderless	8652-134-001	8652-134-001	8652-134-001	8652-134-001	1
*	Lockwasher #10	8641-582-006	8641-582-006	8641-582-006	8641-582-006	1
*	Screw-10-32ttX1x1/2 GRN	9545-008-027	9545-008-027	9545-008-027	9545-008-027	2
11	Strip-Terminal Marking, Injector	9558-028-001	9558-028-001	9558-028-001	9558-028-001	1
12	Terminal Block-Injector	9897-032-002	9897-032-002	9897-032-002	9897-032-002	1
*	Screw-4Bx5/8ss	9545-053-002	9545-053-002	9545-053-002	9545-053-002	2
13	Harness-Injection	9627-799-001	9627-799-001	9627-799-001	9627-799-002	1
14	Label-Warning	8502-639-001	8502-639-001	8502-639-001	8502-639-001	1
15	Bushing-Insulated, 3/4"	9053-067-001	9053-067-001	9053-067-001	9053-067-001	1
16	Bushing-Insulated, 1"	9053-067-004	9053-067-004	9053-067-004	9053-067-004	1
*	Cover, Terminal Block	9074-267-001	9074-267-001	9074-267-001	9074-267-001	1
*	Screw #10Bx1/2	9545-008-026	9545-008-026	9545-008-026	9545-008-026	1
17	Plate-Drive mounting	9982-383-001	9982-383-001	9982-383-001	9982-384-001	1
18	Nut, #10-32UNF, 2B	8460-413-002	8460-413-002	8460-413-002	8460-413-002	4
19	VFD Delta "E" drive 208-240 volt	9375-030-014	9375-028-011	9375-028-018	9375-029-008	1
*	Key Pad-Display Delta "E" Drive (P/S) only	9150-044-001	9150-044-001	9150-044-001	9150-044-001	1
*	VFD Cooling Fan	9189-013-001	9189-013-001	9189-013-001	9189-014-001	1
20	Nut, #10-32UNF, 2B	8460-413-002	8460-413-002	8460-413-002	8460-413-002	4
*	Cable, Data	9806-015-001	9806-015-001	9806-015-001	9806-015-003	1
*	Clamp, Cable	8654-125-005	8654-125-005	8654-125-005	8654-125-005	1
*	VFD MS300 V4	9375-035-015	9375-036-018	9375-036-026	9375-037-005	1
*	VFD Cooling Fan	9189-016-001	9189-016-001	9189-016-001	9189-017-001	1
*	Data Cable MS300 V4	9806-026-001	9806-026-001	9806-026-001	9806-026-002	1
21	Plate-Water Valves, Mounting	9452-813-001	9452-813-001	9452-814-001	9452-814-001	1
22	Nut, #10-32UNF, 2B	8460-413-002	8460-413-002	8460-413-002	8460-413-002	4
23	Valve-Water, Duel Coil	9379-183-012	9379-183-012	9379-183-012	9379-183-012	2
24	Screw #10Bx1/2	9545-008-026	9545-008-026	9545-008-026	9545-008-026	4
25	Water-Valve, Single Coil			9379-194-001	9379-194-001	2
26	Screw-Phillips, 4mx0.7x8mm			9545-064-001	9545-064-001	4
27	Shield, Water Valves	9550-194-001	9550-194-001	9550-195-001	9550-195-001	1
28	Clip-Push	9083-121-001	9083-121-001			3
28	Clip-Push			9083-121-001	9083-121-001	4
29	Cap-Injector Assy	0935-127-001	0935-127-001	0935-127-001	0935-127-001	1
30	Clamp	8654-117-014	8654-117-014	8654-117-014	8654-117-014	1
31	Hose-Suds Overflow	9242-463-004	9242-463-004	9242-463-004	9242-463-006	1
32	Resistors (160 Ohm)	9483-004-003	9483-004-003	9483-004-003	9483-004-003	2
33	Screws #10-32x1/2" (Mounting)	9545-012-008	9545-012-008	9545-012-008	9545-012-008	4
34	Jumper Wires	8220-117-002	8220-117-002	8220-117-002	8220-117-002	2

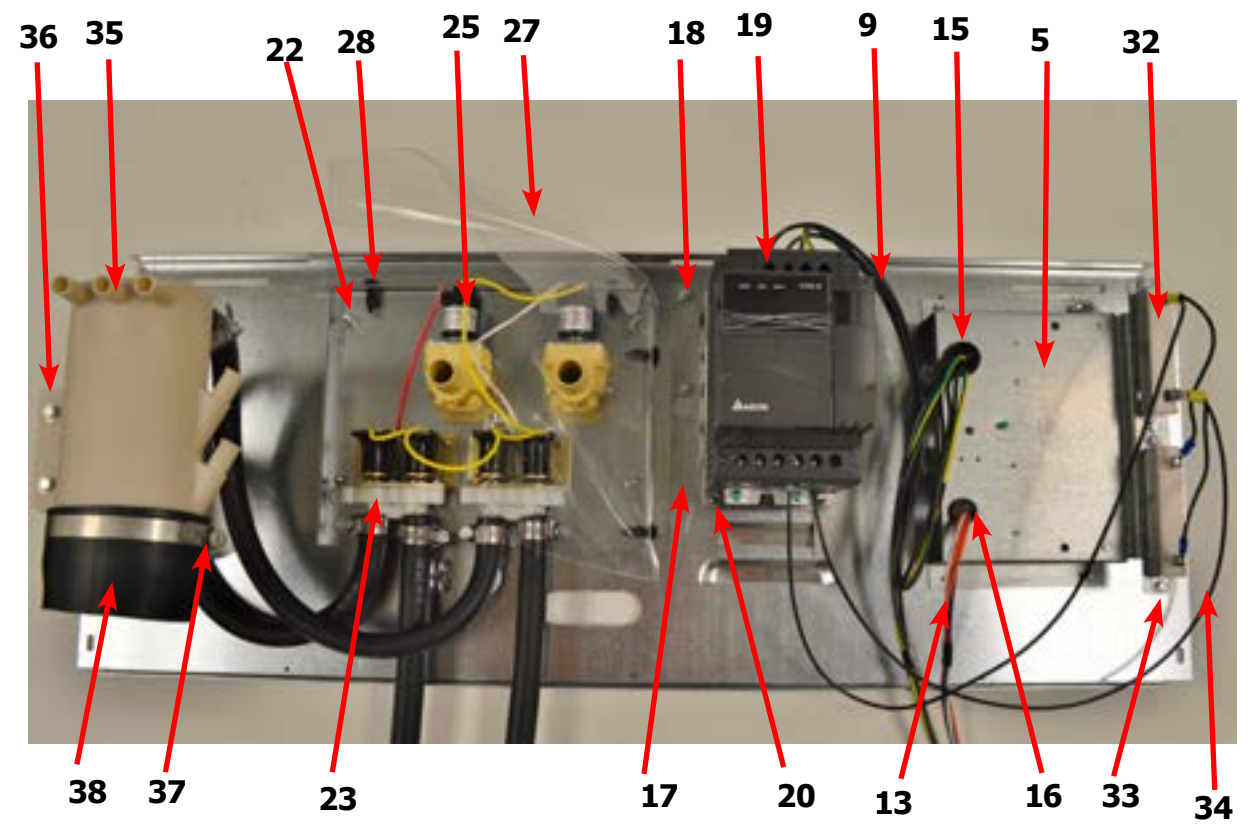
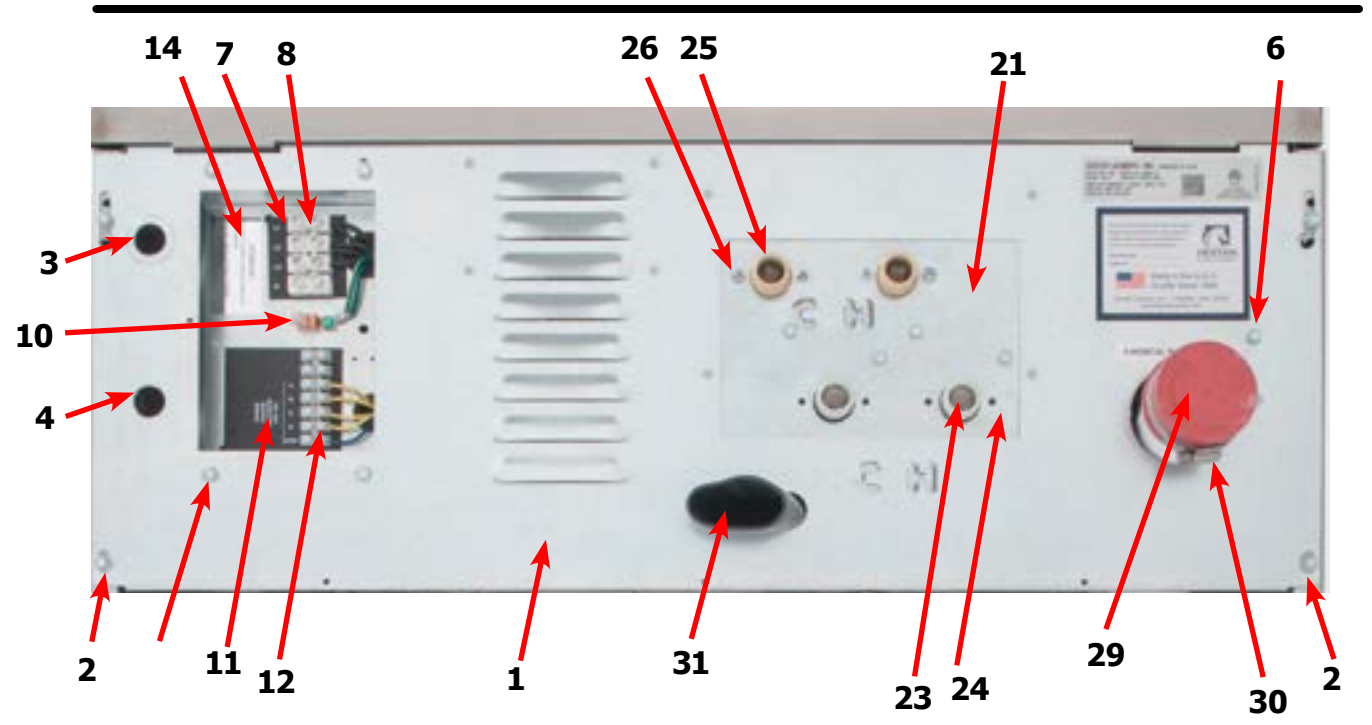

Key	Description	T650	T750	T950	T1450	QTY
35	Vacuum Breaker	9610-001-001	9610-001-001	9610-001-001	9610-001-001	1
*	Bracket-Vacuum Breaker	9029-077-001	9029-077-001	9029-077-001	9029-266-001	1
*	Vacuum Breaker Cap (Red)	0935-135-002	0935-135-002	0935-135-002	0935-135-002	*
36	Screw, 10Bx1/2	9545-008-026	9545-008-026	9545-008-026	9545-008-026	4
37	Clamp, Vacuum Breaker End	8654-117-014	8654-117-014	8654-117-014	8654-117-014	1
38	Hose, Vacuum Breaker to Tub Injection Tube	9242-461-001	9242-461-001	9242-461-001	9242-461-001	1

Cylinder, Seals & Bearings Part # by Model

Key	Description	T650	T750	T950	T1450	QTY
*	Bearings and Seal Kit	9732-219-007	9732-219-007	9732-219-007	9732-219-009	1
1	Housing, Bearing- Assembly (items #2-#6)	9803-187-001	9803-187-001	9803-187-001	9803-209-001	1
2	Housing, Bearing	9241-181-004	9241-181-004	9241-181-004	9241-195-003	1
3	Bearing, Front (LARGE)	9036-159-006	9036-159-006	9036-159-006	9036-162-002	1
4	Bearing, Rear (SMALL)	9036-159-005	9036-159-005	9036-159-005	9036-162-001	1
5	Spacer, Bearing	9538-170-001	9538-170-001	9538-170-001	9538-185-001	1
6	Ring, Bearing Retainer	9487-238-004	9487-238-004	9487-238-004	9487-238-004	1
7	Tub Assembly	9930-168-001	9930-148-001	9930-157-001	9930-155-001	1
8	Seal, Small V85A	9532-140-007	9532-140-007	9532-140-007		1
8	Seal, Small V95A				9532-140-012	1
9	Seal, Large V140A	9532-140-008	9532-140-008	9532-140-008	9532-140-008	1
10	Ring, Seal Mounting	9950-052-001	9487-261-004	9950-052-001	9950-062-001	1
11	Tub Back Mating Ring	9487-266-001	9487-266-001	9487-266-001	9487-276-001?	1
11G	Mating Ring Guard Shield	9487-261-004	9487-261-004	9487-261-004	9487-261-005	1
12	Bolt, Tub End of Bearing Housing (7/16-14x1), Bolt from inside Tub	9545-059-004	9545-059-004	9545-059-004	9545-059-004	6
13	Washer, Flat	8641-581-034	8641-581-034	8641-581-034	8641-581-034	6
14	Screw-Hex Cap, 3/4"-10 x 3" (Bearing Housing to Frame)	9545-057-002	9545-057-002	9545-057-002		6
14	Screw-Hex Cap, 7/8"-10 x 3" (Bearing Housing to Frame)				9545-066-001	6
15	Washers Spherical 3/4 (Male half) (Bearing Housing to Frame)	8641-588-001	8641-588-001	8641-588-001		6
15	Washers Spherical 7/8 (Male half) (Bearing Housing to Frame)				8641-588-003	6
16	Washers Spherical 3/4 (Female half) (Bearing Housing to Frame)	8641-588-002	8641-588-002	8641-588-002		6
16	Washers Spherical 7/8 (Female half) (Bearing Housing to Frame)				8641-588-004	6
15	Washer, Flat					6
16	Lock Washer-External Tooth, 3/4" (Bearing Housing to Frame)					6
17	Nut 3/4"-10 (Bearing Housing to Frame)	8640-418-003	8640-418-003	8640-418-003		6
17	Nut 7/8"-9 (Bearing Housing to Frame)				8640-437-001	6
18	Pulley, Driven	9453-173-002	9453-173-002	9453-176-006	9453-176-006	1
*	Tolerance Ring	9487-234-004	9487-234-004			1
*	Screw, 5/8"-11 x 2"	9545-060-004	9545-060-004			1
*	Washer-Flat, 5/8"	8641-581-032	8641-581-032			1
*	Washer-Flat, 5/8"	8641-582-018	8641-582-018			1
19	Bolt, 3/8"-16 x 2"			9545-029-011	9545-029-011	3
20	Washer, 3/8"			8641-582-003	8641-582-003	3
21	Bushing Taperlock (Driven & Large)			9053-078-002	9053-078-002	1
22	Washer-Flat .675x2-1/2x1/4			8641-581-043		1
23	Lockwasher-Exttooth, 5/8			8641-582-018		1
24	Bolt, 5/8-11x1 1/2			9545-060-001		1
22	Washer-Flat, .781x2-1/2x1/4				8641-581-044	1
23	Lockwasher-Exttooth, 3/4				8641-582-020	1
24	Bolt, 3/4-10-1 1/2				9545-057-004	1
25	Tub & Cylinder Assy	9869-035-002	9869-025-001	9869-027-003	9869-026-001	1

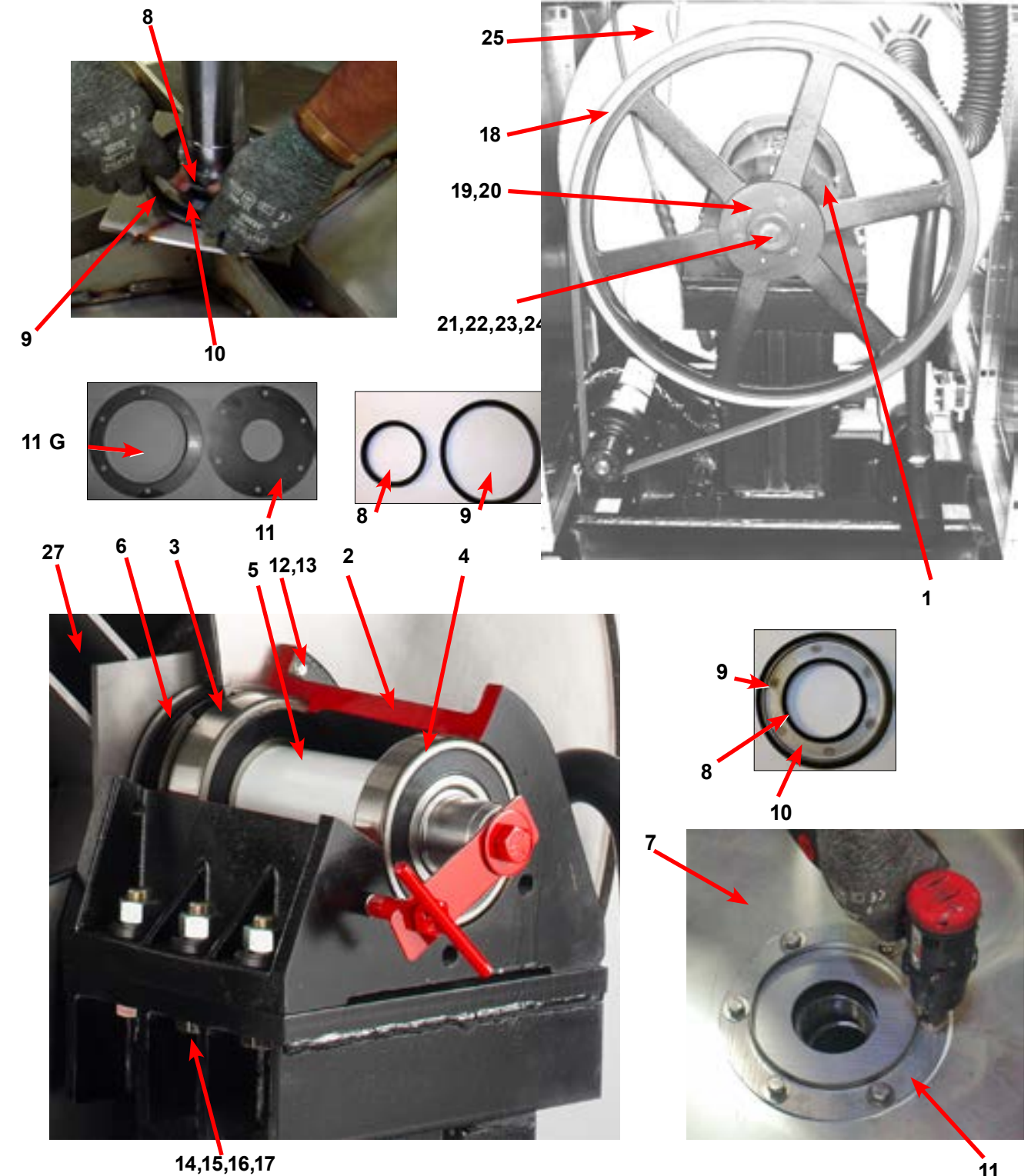

Key	Description	T-650	T750	T950	T1450	QTY
27	Cylinder Assy	9848-145-001	9848-136-002	9848-136-001	9848-141-001	
*	Tub Front	9974-014-002	9974-011-001	9974-011-001	9974-012-001	1
*	Gasket, Tub Front	9206-421-002	9206-421-002	9206-421-002	9206-421-003	1
*	Ring Assy, Tub Mtg-Front Clamp	9950-063-001	9950-055-001	9950-055-001	9950-061-001	1
*	Bolt, Top Front Ring 3/8"-16 x 3"	9545-029-009	9545-029-009	9545-029-009	9545-029-009	1
*	Nut WCAD 3/8"-16	8640-415-001	8640-415-001	8640-415-001	8640-415-001	1

Door Lock Assembly (All Models)

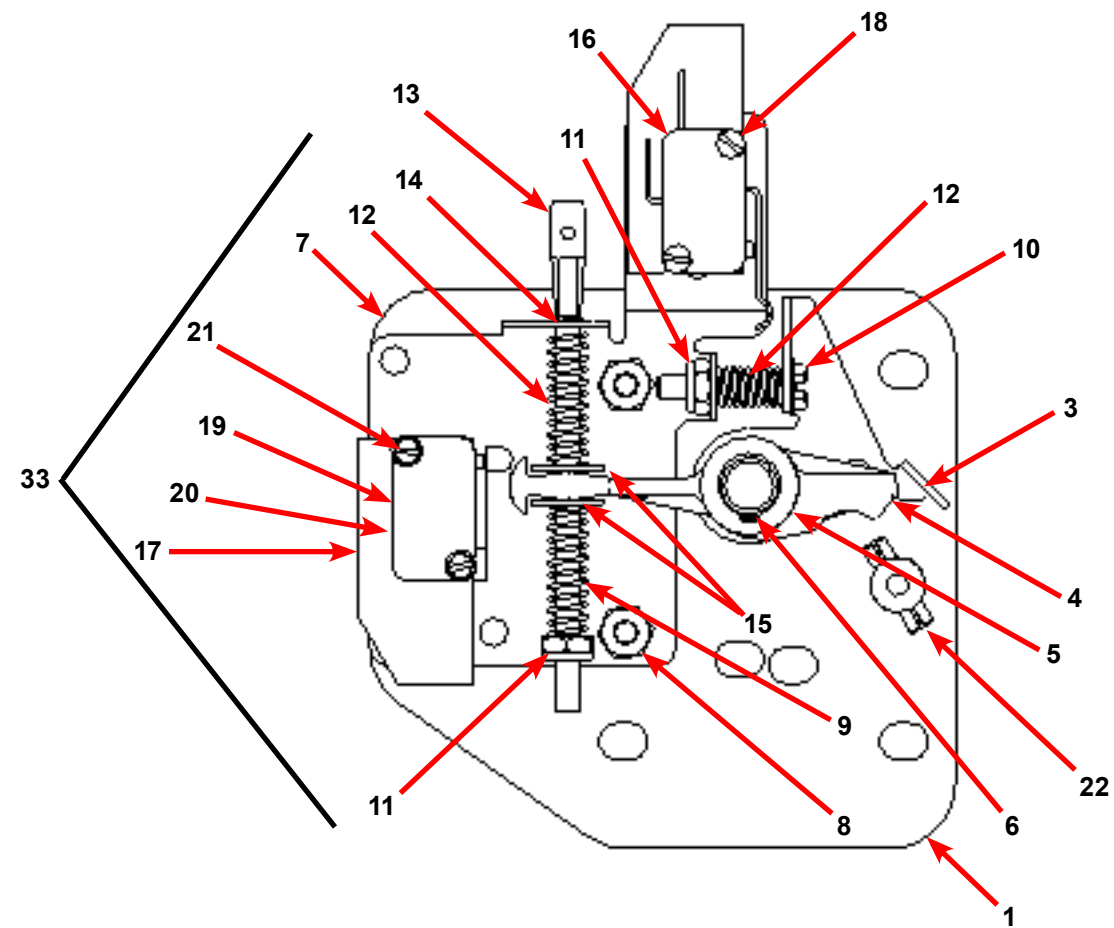

Key	Description	All Models	QTY
33	Lock Assy, Complete (#1-22) (includes #1 thru #22)	9885-031-001	1
1	Plate Assy, Door Lock	9982-346-001	1
2	Washer, Flat (SS or Brass)	8641-581-030	1
3	Actuator, Latching Switch	9008-005-001	1
4	Pawl, Locking	9732-346-002	1
5	Washer, Spring	8641-569-003	1
6	Ring, Retaining	9487-200-004	1
7	Bracket Switch	9029-163-001	1
8	Nut, Hex 10-32 UNF	8640-413-002	2
9	Spring, Actuating	9534-364-002	1
10	Screw, Hx. 10-32 x 1"	9545-012-020	1
11	Nut, Elastic Stop 10-32	8640-413-004	2
12	Spring, Return	9534-364-001	2
13	Pin, Guide	9451-193-001	1

Key	Description	All Models	QTY
14	Ring, Retaining	9487-200-005	1
15	Washer	8641-581-031	1
16	Switch, Latching Sensing	9539-461-008	1
17	Shield, Switch	9550-169-003	3
18	Screw 4-40 x 5/8"	9545-020-001	2
18	Nut, Twin 4-40	8640-401-001	1
19	Switch, Locking Sensing	9539-461-007	2
20	Actuator, Switch Locking	9008-006-003	1
21	Screw 4-40 x 1 1/8"	9545-020-003	2
21	Nut, Twin 4-40	8640-401-001	1
*	Spacer Sensor	9538-182-001	*
22	Pin, Dowel (for door cam)	9451-181-004	1
*	Shim, Door Lock, Thin	9552-037-001	AR
*	Screw, Lock mtg 1/4"-20 x 3/4"	9545-018-014	3
*	Lockwasher 1/4" Ext tooth	8641-582-007	3
*	Door Stud Pin, 3/16" x 3/4"	9451-181-004	1

Gear Motor Door Lock Assembly

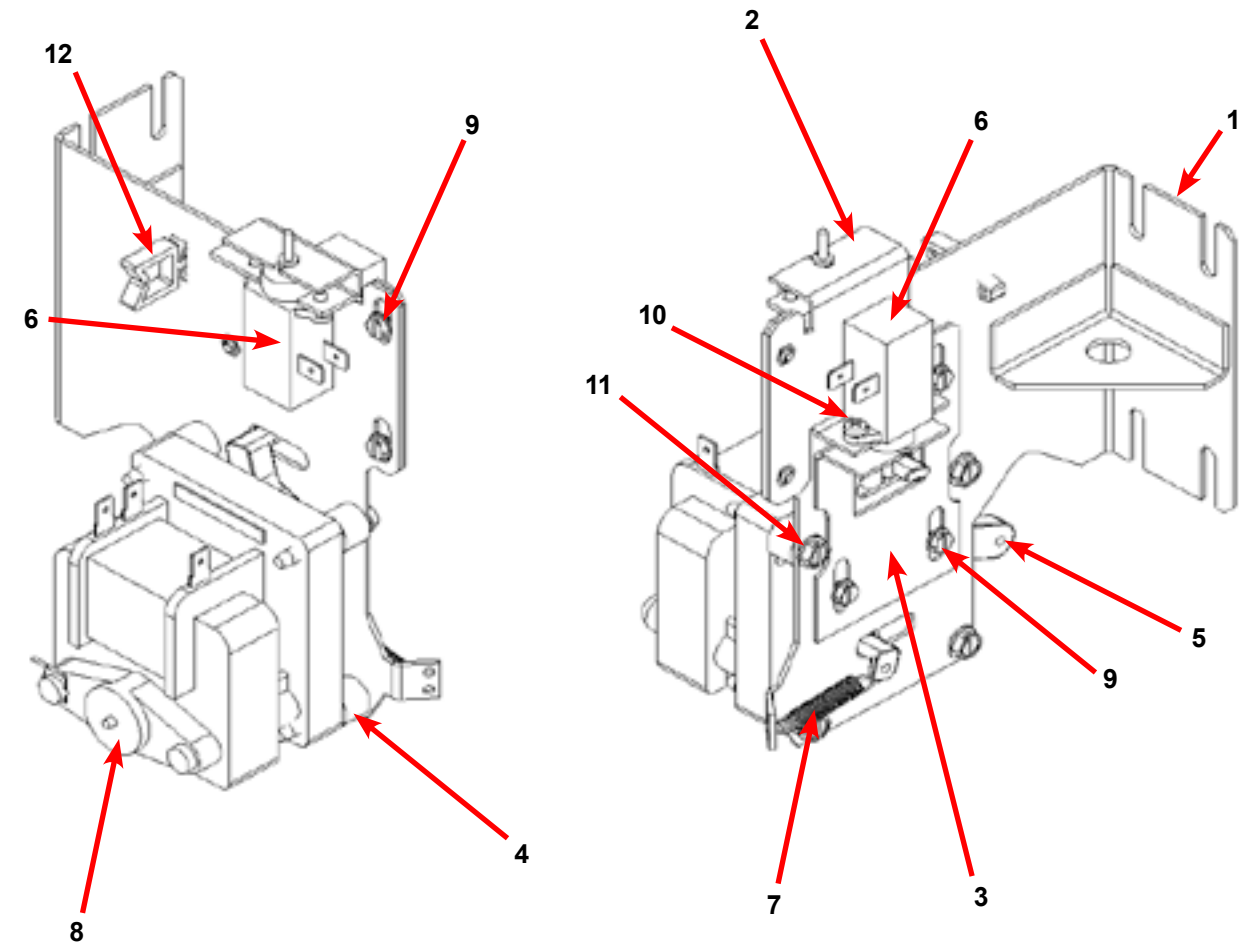

Key	Description	T650	T750	T950	T1450	QTY
*	Actuator Assembly (Includes 1-10, Rod NOT included)	9892-015-001	9892-015-001	9892-015-001	9892-015-001	1
11	Screw - hxwshdsl, 10-24 - 1.25f, ctd	9545-046-007	9545-046-007	9545-046-007	9545-046-007	4
10	Cross Recessed PAn Hd Tapping screw	9545-031-011	9545-031-011	9545-031-011	9545-031-011	4
9	Screw -Hxwshrdslsems, 6-32 x 3/16	9545-044-003	9545-044-003	9545-044-003	9545-044-003	6
8	Motor & Gear Assembly 120v	9914-137-015	9914-137-015	9914-137-015	9914-137-015	1
7	Spring - Extension	9534-350-001	9534-350-001	9534-350-001	9534-350-001	1
6	Thermoactuator - Door Lock Relay 120v	9586-001-001	9586-001-001	9586-001-001	9586-001-001	2
5	Arm - Door Lock	9001-063-001	9001-063-001	9001-063-001	9001-063-001	1
4	Spacer, Plastic	9538-157-021	9538-157-021	9538-157-021	9538-157-021	4
3	Bracket Slide Lock	9029-204-001	9029-204-001	9029-204-001	9029-204-001	1
2	Bracket Assy, Slide - Unlock	9985-189-001	9985-189-001	9985-189-001	9985-189-001	1
1	Bracket Assy, Slide Lock Actuator	9985-190-001	9985-190-001	9985-190-001	9985-190-001	1
*	Rod, Door Lock	9497-225-017	9497-225-013	9497-225-015	9497-225-016	1

Large Door & Hinge Group (After #514975)

Key	Description	T650	T750	T950	T1450	QTY
1	Door Hinge Assembly (mounts to tub front)	9955-030-001	9955-031-001	9955-031-001	9955-031-001	1
*	Door Assembly Complete	9960-309-001	9960-310-001	9960-310-001	9960-310-001	1
2	Door Ring 180 degree large hnge	9487-265-002	9487-275-001	9487-275-001	9487-275-001	1
3	Door Gasket	9206-419-001	9206-431-001	9206-431-001	9206-431-001	1
4	Door Glass Window	9635-016-001	9635-020-001	9635-020-001	9635-020-001	1
*	Red Wire (Door Close Switch)	8220-063-025	8220-063-028	8220-063-028	8220-063-028	1
	Black Wire (Door Close Switch)	8220-063-026	8220-063-029	8220-063-029	8220-063-029	1
5	Switch, Door Hinge Close (Plunger)	9539-492-001	9539-492-001	9539-492-001	9539-492-001	1
6	Top Door Hinge Leaf (No pin)	9845-008-001	9845-006-001	9845-006-001	9845-006-001	1
7	Bottom Door Hinge Leaf	9845-005-001	9845-007-001	9845-007-001	9845-007-001	1
8	Thrd Form Screw, Door Mtg 5/16" x 5/8"	9545-056-002				3
8	Thrd Form Screw, Door Mtg 5/16" x 5/8"		9545-056-002	9545-056-002	9545-056-002	4
9	Screw, Loading Door Hinge Mtg (5/16" x9/16" ss)	9545-014-009	9545-014-013	9545-014-013	9545-014-013	3
10	Bracket Retainer support side panel	9045-094-001	9045-085-001	9046-085-001	9046-085-001	1
*	Shim Large door	9552-043-001	9552-043-001	9552-043-001	9552-043-001	1

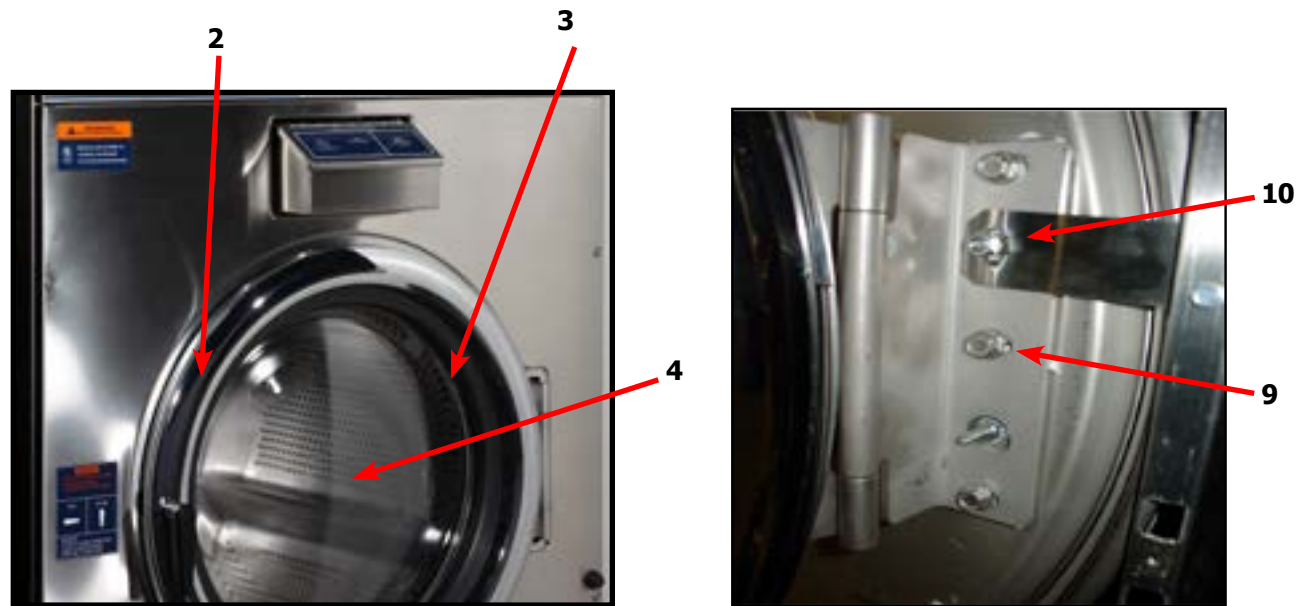

Key	Description	T650	T750	T950	T1450	QTY
*	Shaft Assembly (includes 11-13)	9913-134-003	9913-134-003	9913-134-003	9913-134-003	
11	Shaft, Door Locking	9537-195-002	9537-195-002	9537-195-002	9537-195-002	1
12	Cam, Locking	9095-051-001	9095-051-001	9095-051-001	9095-051-001	1
13	Pin, Groove (1 1/4)	9451-181-005	9451-181-005	9451-181-005	9451-181-005	1
14	Pin, Groove (3/4)	9451-181-004	9451-181-004	9451-181-004	9451-181-004	1
15	Spring, Lock Cam	9534-360-002	9534-360-002	9534-360-002	9534-360-002	1
16	Handle, Door	9244-091-001	9244-091-001	9244-091-001	9244-091-001	1
17	Pin, Door Handle (groove)	9451-181-005	9451-181-005	9451-181-005	9451-181-005	1

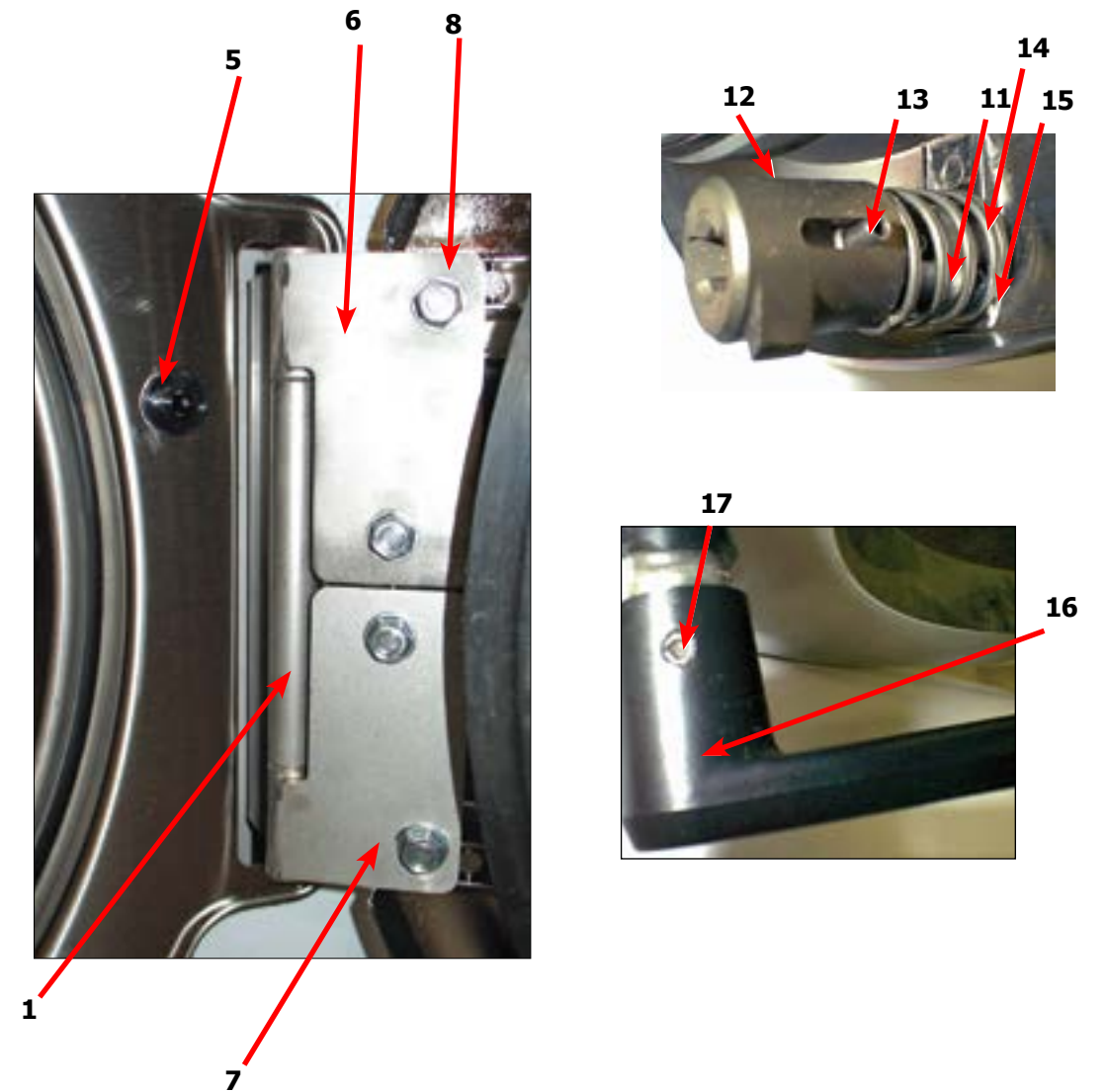

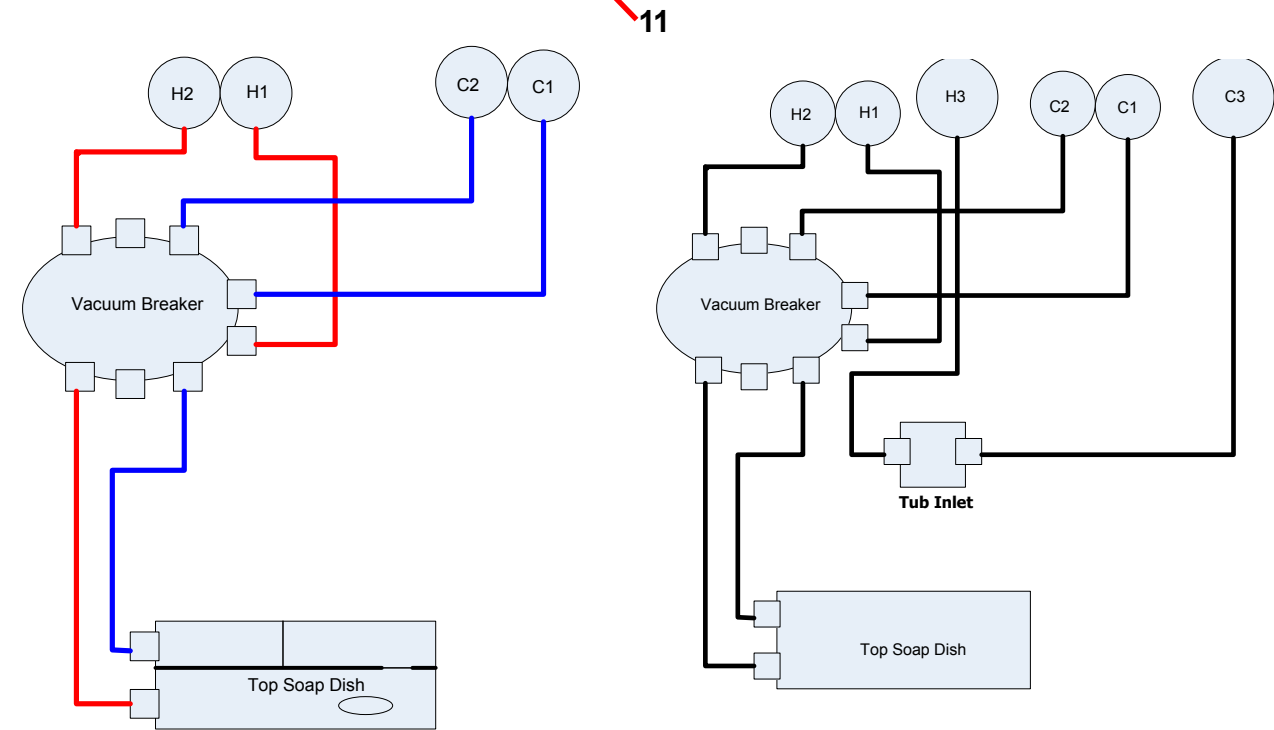
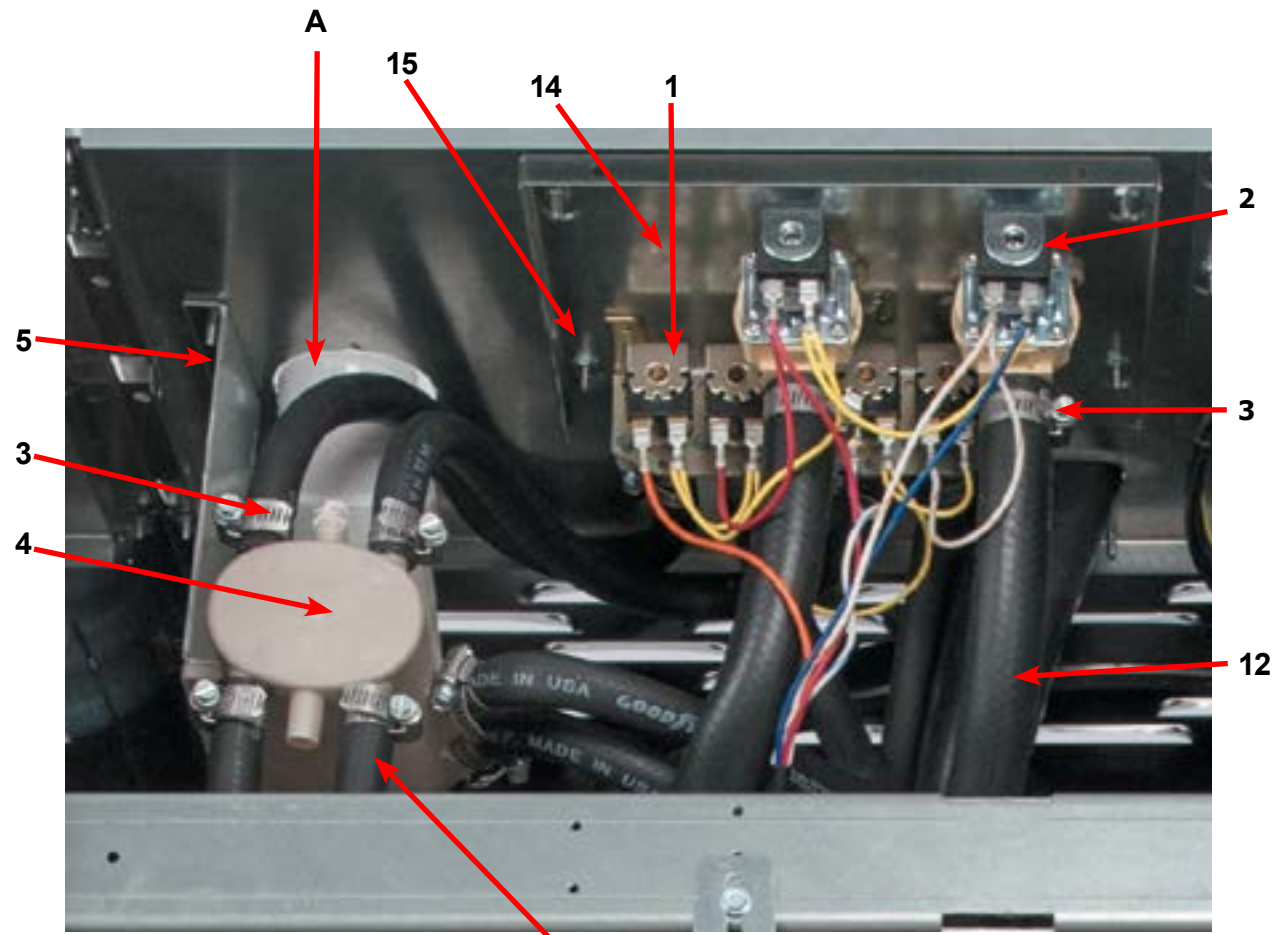

Top Soap Box Design

Top Soap Box 4 Valve Design

Water Inlet Part # by Model

Key	Description	T650	T 750	T950	T1450	QTY
A	Injector Assembly	9883-005-001	9883-005-001	9883-012-001	9885-011-001	1
1	Valve, Water Inlet (dual outlet) (see Water Inlet Valve Breakdown for individual parts)	9379-183-012	9379-183-012	9379-183-012	9379-183-012	2
*	Screw, Valve Mtg	9545-008-026	9545-008-026	9545-008-026	9545-008-026	2
2	Valve Water Inlet (single outlet)			9379-194-001	9379-194-001	2
*	Screw, Valve M4x0.7x8mm			9495-064-001	9545-064-001	8
3	Clamp-Water Valves	8654-117-008	8654-117-008	8654-117-008	8654-117-008	AR
*	Shield over Water Valves Plastic	9550-194-001	9550-194-001	9550-195-001	9550-186-001	1
*	Clip-Push	9083-121-001	9083-121-001			3
*	Clip-Push			9083-121-001	9083-121-001	4
4	Vacuum Breaker	9610-001-001	9610-001-001	9610-001-001	9610-001-001	1
5	Bracket, Vacuum Breaker	9029-077-001	9029-077-001	9029-077-001	9029-266-001	1
*	Screw	9545-008-026	9545-008-026	9545-008-026	9545-008-026	4
6	New Front Mount Soap Box, 2 port				9732-290-001	1
7	Fitting, Cross (new soap bhox)				8615-118-001	
*	Clamp, Vacuum Breaker End	8654-117-014	8654-117-014	8654-117-014	8654-117-014	1
9	Hose, Vacuum Breaker to Tub Injection Tube	9242-461-001	9242-461-001	9242-461-001	9242-461-001	1
10	Flow restrictor	9475-002-002	9475-002-002	9475-002-002	9475-002-002	2
11	1/2 inch hose, cut to length					
12	3/4 inch hose, cut to length					
13	Flow restrictor			9475-002-002	9475-002-003	3
*	Tub Fill Inlet Cap					2
14	Plate-Water Valves, Mounting	9452-813-001	9452-813-001	9452-814-001	9452-814-001	1
15	Nut, #10-32UNF, 2B	8460-413-002	8460-413-002	8460-413-002	8460-413-002	4

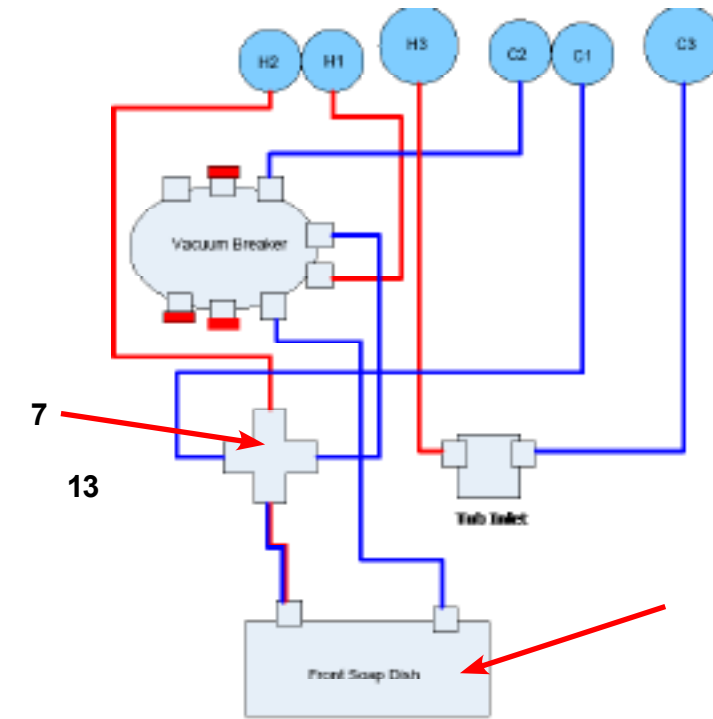

New Front Soap Box Design

Water Inlet Valve Breakdown Part # by Model

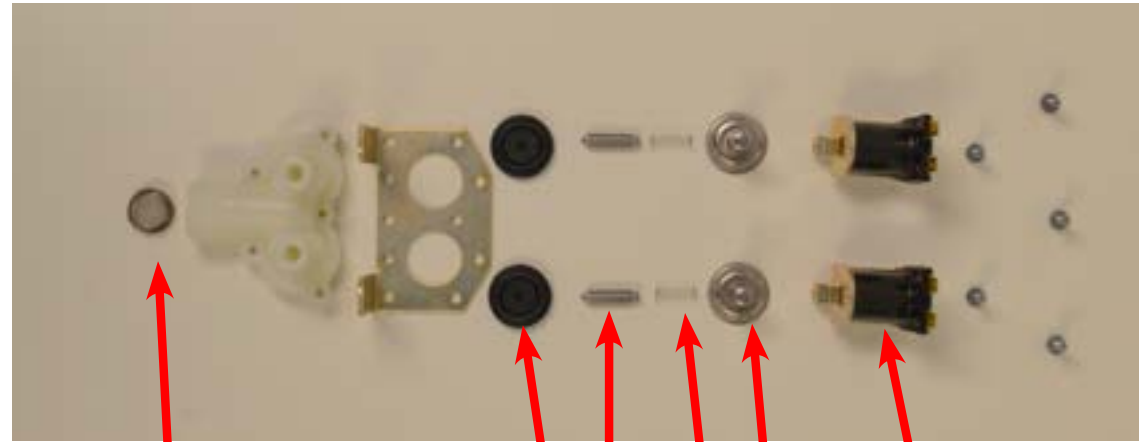

Key	Description	T650	T750	T950	T1450	QTY
*	Valve, Water Inlet (includes 1 thru 6)	9379-183-012	9379-183-012	9379-183-012	9379-183-012	2
1	Screen, Inlet end of valve	9555-056-001	9555-056-001	9555-056-001	9555-056-001	2
2	Coil Assy., 120 V Invensys	9089-017-001	9089-017-001	9089-017-001	9089-017-001	2
*	Diaphragm Invensys (EPDM)	9118-049-001	9118-049-001	9118-049-001	9118-049-001	2
*	Diaphragm Invensys (Viton)	9118-049-002	9118-049-002	9118-049-002	9118-049-002	2
3	Diaphragm Invensys (EPDM NSF)	9118-049-003	9118-049-003	9118-049-003	9118-049-003	2
4	Guide, Solenoid Invensys	9211-021-002	9211-021-002	9211-021-002	9211-021-002	2
5	Armature Invensys	9015-008-001	9015-008-001	9015-008-001	9015-008-001	2
6	Spring, Armature Invensys	9534-298-001	9534-298-001	9534-298-001	9534-298-001	2

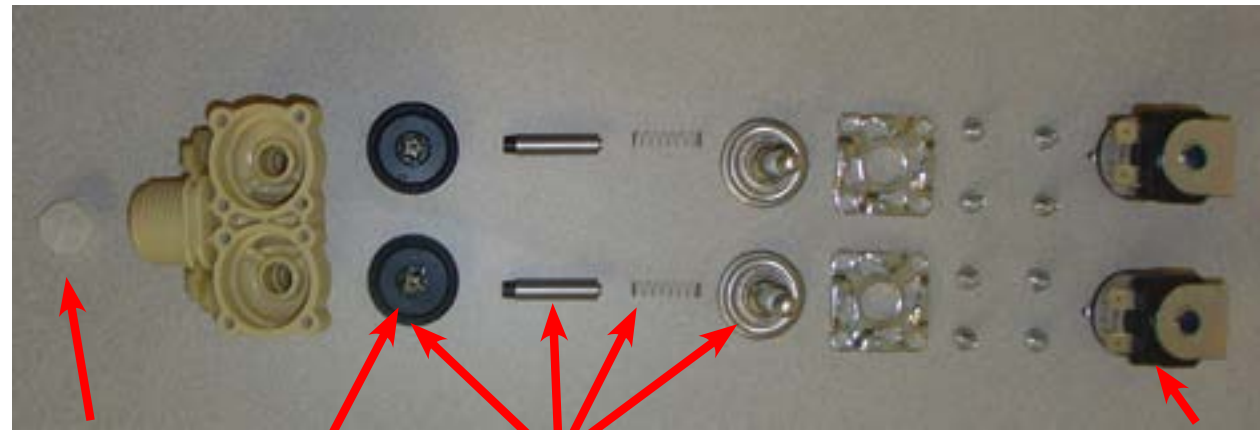

Optional Water Valve

Key	Description	650	T750	T950	T1450	QTY
*	Dual Coil Water Valve Mueller	9379-192-001	9379-192-001	9379-192-001	9379-192-001	1
7	Valve Water Body Complete(no coil)	9379-192-002	9379-192-002	9379-192-002	9379-192-002	1
8	Diaphragm Mueller	9118-054-001	9118-054-001	9118-054-001	9118-054-001	2
9	Filter Mueller	9183-046-001	9183-046-001	9183-046-001	9183-046-001	2
10	Coil Mueller	9089-051-001	9089-051-001	9089-051-001	9089-051-001	2
11	Diaphragm Assembly Mueller Includes	9785-001-001	9785-001-001	9785-001-001	9785-001-001	2

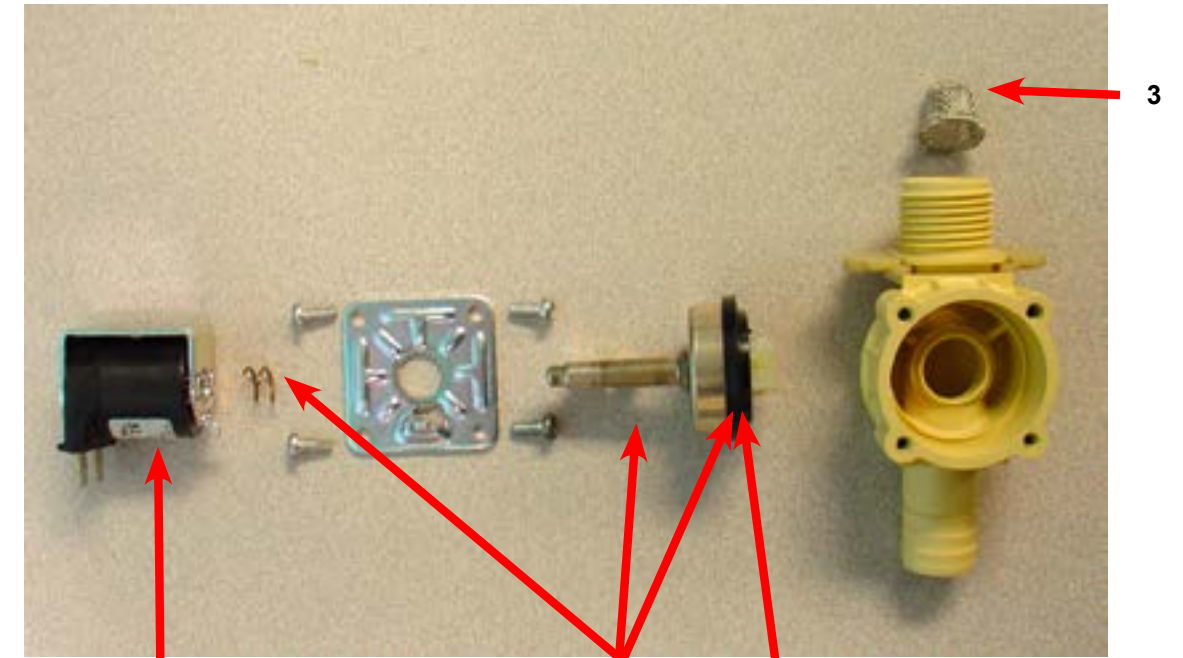

Key	Description	T650	T750	T950	T1450	QTY
*	Single Coil Water Valve Mueller			9379-194-001	9379-194-001	1
1	Valve Water Body Complete (no coil)			9379-194-002	9379-194-002	1
2	Diaphragm Mueller			9118-055-001	9118-055-001	1
3	Filter Mueller			9183-046-001	9183-046-001	1
4	Coil Mueller			9089-051-001	9089-051-001	1

Notes

Drain Valve Group Part # by Model

Key	Description	Part Number	Qty
1	Valve, Drain (includes #2 thru #11)	9379-202-001	1
2	Body, Valve (w/ball)	9064-072-001	1
3	Motor & Gear Train (complete)	9914-137-023	1
4	Plate, Motor Mtg	9452-538-001	1
5	Screw	8639-994-001	1
6	Spring, Drive	9534-339-001	1
7	Screw	9545-054-001	1
8	Screw	9545-054-002	1
9	Seal, V Packer	9532-134-001	1
10	Washer	8641-584-001	1
11	Pin, Main Drive	9451-196-001	1
*	Plate (spacers needed for replacement motor mtg. plate)	9538-149-001	1
12	Kit - Seal Replacement	9732-327-001	1

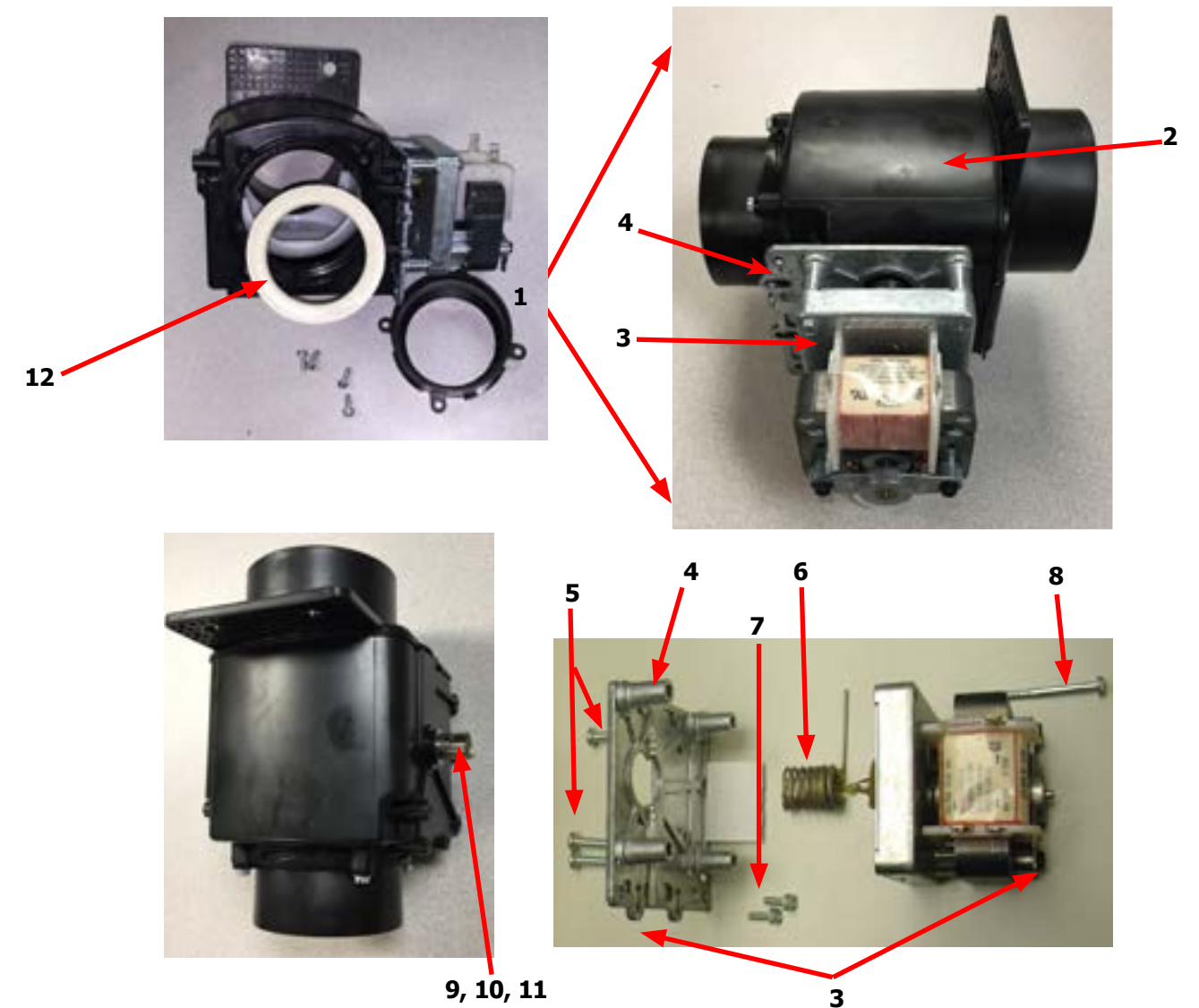

Chassis and Drain Part # by Model

Key	Description	T-650	T750	T950	T1450	QTY
1	Base Assy,Frame	9945-143-002	9945-112-002	9945-155-002	9945-133-002	1
2	Outer Tub Assy.	9930-168-001	9930-148-001	9930-157-001	9930-155-001	1
*	Tub & Cylinder Assy.	9869-035-002	9869-025-001	9869-027-003	9869-026-002	1
3	Tub Front	9974-014-002	9974-011-001	9974-011-001	9974-012-001	1
*	Gasket, Tub Front	9206-421-004	9206-421-002	9206-421-002	9206-421-003	1
4	Ring Assy, Tub Mtg-Front Clamp	9950-063-001	9950-055-001	9950-055-001	9950-061-001	1
5	Bolt, Top Front Ring 3/8"-16 x 3"	9545-029-009	9545-029-009	9545-029-009	9545-029-009	1
6	Nut WCAD 3/8"-16	8640-415-001	8640-415-001	8640-415-001	8640-415-001	1
7	Bolt, 1/2" -13 x 2" Rings to Base	9545-017-013	9545-017-013	9545-017-013	9545-017-013	2
8	Nut, Wizloc 1/2" x 13	8640-417-005	8640-417-005	8640-417-005	8640-417-005	2
9	Washer, Flat 1/2"	8641-581-026	8641-581-026	8641-581-026	8641-581-026	2
10	Hose, Tub to Drain Valve	9242-464-001	9242-456-001	9242-459-001	9242-459-001	1
11	Clamp, Hose (Tub to Drain Valve)	8654-117-014	8654-117-014	8654-117-014	8654-117-014	2
12	Valve, Drain	9379-202-001	9379-202-001	9379-202-001	9379-202-001	1
*	Screw, Valve to Base 1/4ABx3/4	9545-030-002	9545-030-002	9545-030-002	9545-030-002	2
*	Washer, Flat 1/4	8641-581-017	8641-581-017	8641-581-017	8641-581-018	2
13	Hose, Drain Valve to Tube	9242-457-001	9242-457-001	9242-457-001	9242-457-002	1
*	Clamp, Hose (Drain Valve to Tube)	8654-117-014	8654-117-014	8654-117-014	8654-117-014	2
14	Tube Assy, Drain	9915-124-002	9915-124-002	9915-120-004	9915-129-002	1
15	Clamp, Hose (Tube to Frame Bracket)	8654-117-014	8654-117-014	8654-117-014	8654-117-014	1
*	Bracket, Drain Tube			9029-162-002		1
*	Screw Tube (Bracket to Base 1/4Bx3/4)	9545-030-002	9545-030-002	9545-030-002		4
16	Hose, Overflow Tub To Drain Tube	9242-449-002	9242-449-003	9242-449-003	9242-449-005	1
*	Clamp, Hose	8654-117-018	8654-117-018	8654-117-018	8654-117-018	2
17	Tube, Suds overflow	9242-463-004	9242-463-004	9242-463-004	9242-463-006	1
*	Clamp, Hose	8654-117-008	8654-117-008	8654-117-008	8654-117-008	2
18	Hose, Pressure switch	9242-175-004	9242-175-007	9242-175-007	9242-175-004	1
	Clamp, Overflow Hose	8654-117-015	8654-117-015	8654-117-015	8654-117-015	1

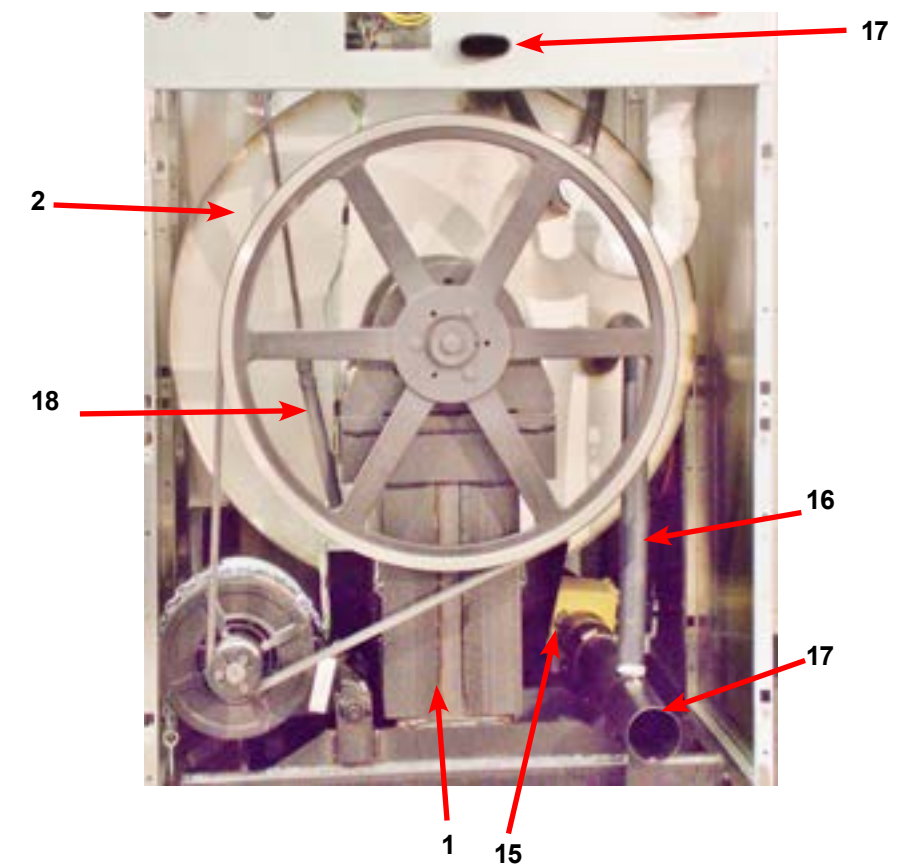
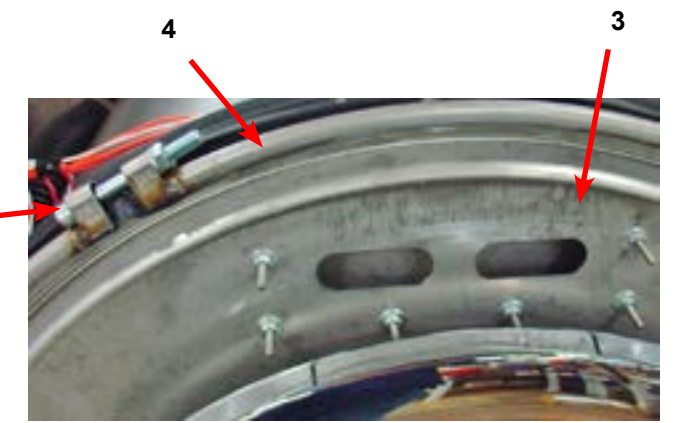
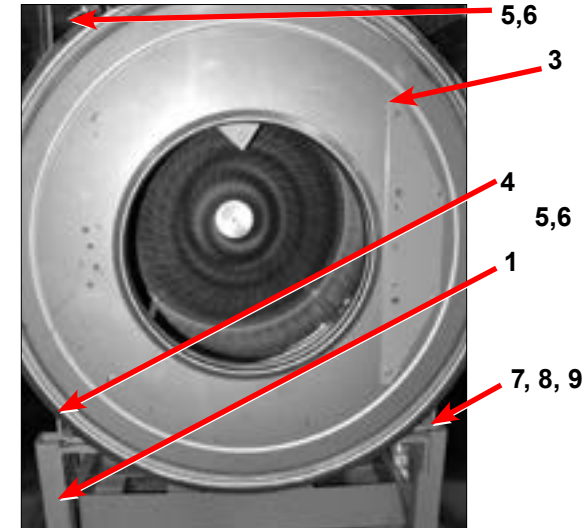
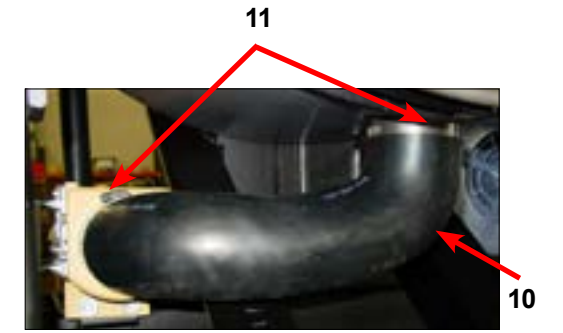
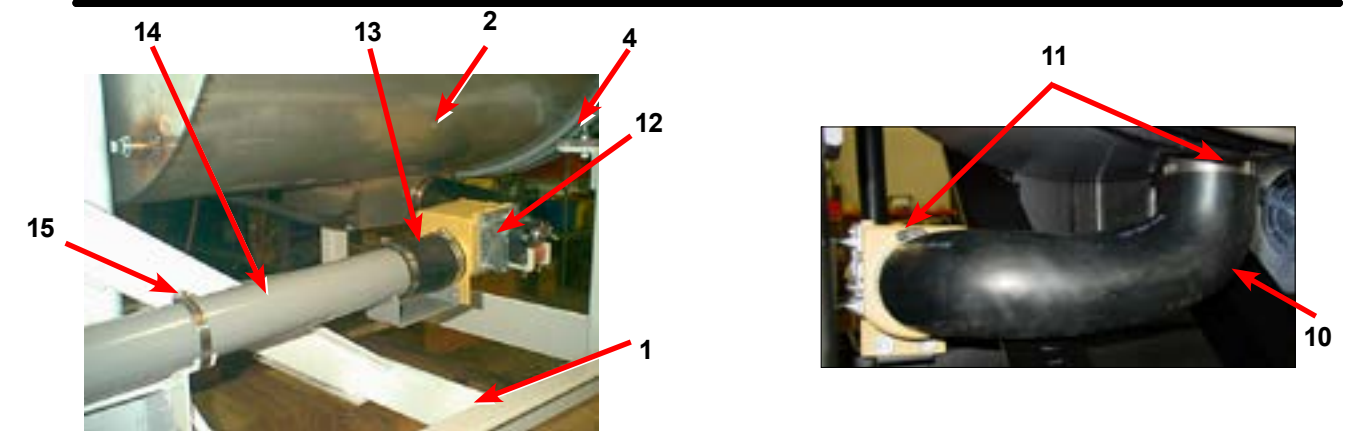

Key	Description	T650	T750	T950	T1450	QTY
1	Trough Assy,Controls 208-240 volt (all parts below #2-#43)	9857-221-001	9857-215-001	9857-216-002	9857-218-001	1
*	Trough only	9839-018-001	9839-018-001	9839-018-001	9839-017-001	1
*	Screw, Trough Sides	9545-008-026	9545-008-026	9545-008-026	9545-008-026	4
*	Lockwasher #10	8641-582-006	8641-582-006	8641-582-006	8641-582-006	4
*	Angle Support Trough	9003-278-001	9003-278-001	9003-271-001		1
*	Screw, Trough Bracket	9545-008-026	9545-008-026	9545-008-026	9545-008-026	4
*	Channel-Trough Mounting	9081-136-001	9081-136-001	9081-108-001	9801-155-001	1
*	Screw-10Bx1/2	9545-008-026	9545-008-026	9545-008-026	9545-008-026	4
2	Screw GRN. #10-32x 1/2"	9545-008-027	9545-008-027	9545-008-027	9545-008-027	1
*	Lockwasher #10	8641-582-006	8641-582-006	8641-582-006	8641-582-006	1
3	Transformer, Control (Secondary Voltage to 115 volts)	8711-004-001	8711-004-001	8711-004-001	8711-004-001	1
4	Screw, Mtg #10Bx1/2"	9545-008-026	9545-045-001	9545-045-001	9545-045-001	4
*	Lockwasher #10	8641-582-006	8641-582-006	8641-582-006	8641-582-006	4
5	Terminal Block Assy, POWER	9897-026-004	9897-026-004	9897-026-004	9897-026-004	1
*	Screw, Mtg 8Bx3/8"	9545-045-012	9545-045-007	9545-045-007	9545-045-007	2
6	Transformer, (Step Down) 120/2.3 VAC&24 VAC 50/60hz	8711-009-001	8711-009-001	8711-009-001	8711-009-001	1
*	Lockwasher #6 exttooth	8641-582-005	8641-582-005	8641-582-005	8641-582-005	4
7	Screw, Mtg #8Bx1/4"	9545-045-001	9545-045-001	9545-045-001	9545-045-001	4
8	PCB assembly Relay Main	9473-006-001	9473-006-001	9473-006-001	9473-006-001	1
*	Support-3/8" Edge Holding	9548-285-001	9548-285-001	9548-285-001	9548-285-001	6
9	Bushing , Wire 7/8	9053-067-002	9053-067-002	9053-067-002	9053-067-002	2
*	Wire Assy, Enable-Yellow 32"	8220-064-023	8220-064-023	8220-064-023	8220-064-023	2
10	Harness, P17 Drain/Therm/Sol	9627-796-002	9627-796-002	9627-796-002	9627-796-002	1
11	Harness P19/Water Valve	9627-795-004	9627-795-004	9627-795-004	9627-795-004	1
*	Harness P8/P16 , Control	9627-794-001	9627-794-001	9627-794-004	9627-794-001	1
12	Harness P20/P21, Enable	9627-793-001	9627-793-001	9627-793-001	9627-793-001	1
13	Optional Relay board	9473-007-001	9473-007-001	9473-007-001	9473-007-001	1
14	Support-3/8" Edge Holding	9548-285-001	9548-285-001	9548-285-001	9548-285-001	4
15	Harness, P10 To Terminal Block	9627-799-001	9627-799-001	9627-799-001	9627-799-001	1
16	Harness, P15/P23 Injection	9627-798-001	9627-798-001	9627-798-001	9627-798-001	1
17	Switch, Pressure		9539-490-001	9539-490-001	9539-490-002	1
18	Harness P5/Pressure	9627-806-001	9627-807-001	9627-807-001	9627-900-001	1
*	Standoff Twistlock	9527-002-002	9527-002-002	9527-002-002	9527-002-002	4
19	Fuse Holder Assy	9200-001-002	9200-001-002	9200-001-002	9200-001-002	1
*	Fuse, 1.5Amp	8636-018-001	8636-018-001			1
*	Fuse, 2.5Amp			8636-018-004	8636-018-004	1
20	Label-Fuse, 1.5Amp	8502-716-001	8502-716-001	8502-716-001		1
20	Label-Fuse, 1.5Amp				8502-716-002	1
*	Terminal Grounding,	8652-130-037	8652-130-037	8652-130-037	8652-130-037	1
*	Screw 10-32 x 1/2 GRN	9545-008-027	9545-008-027	9545-008-027	9545-008-027	1
*	Lockwasher, #10	8641-582-006	8641-582-006	8641-582-006	8641-582-006	1
*	Kit-Pressure Sensor, Electronic	9732-314-001	9732-314-001	9732-314-001	9732-314-001	1
21	Kit-Repaacement, Pressure Sensor (only)	9732-315-001	9732-315-001	9732-315-001	9732-315-001	1
*	Support-PCB, 3/8", Edge Holding	9458-285-001	9458-285-001	9458-285-001	9458-285-001	1
22	Transformer-120/18VAC, 5 VA	8711-015-001	8711-015-001	8711-015-001	8711-015-001	1
23	Screw, 8B x 1/4	9545-045-001	9545-045-001	9545-045-001	9545-045-001	1
*	Wire Assy BLK/BLU	8220-001-233	8220-001-233	8220-001-233	8220-001-233	1
*	Wire Assy RED/BLU	8220-001-232	8220-001-232	8220-001-232	8220-001-232	1

Electrical Components - Top Compartment

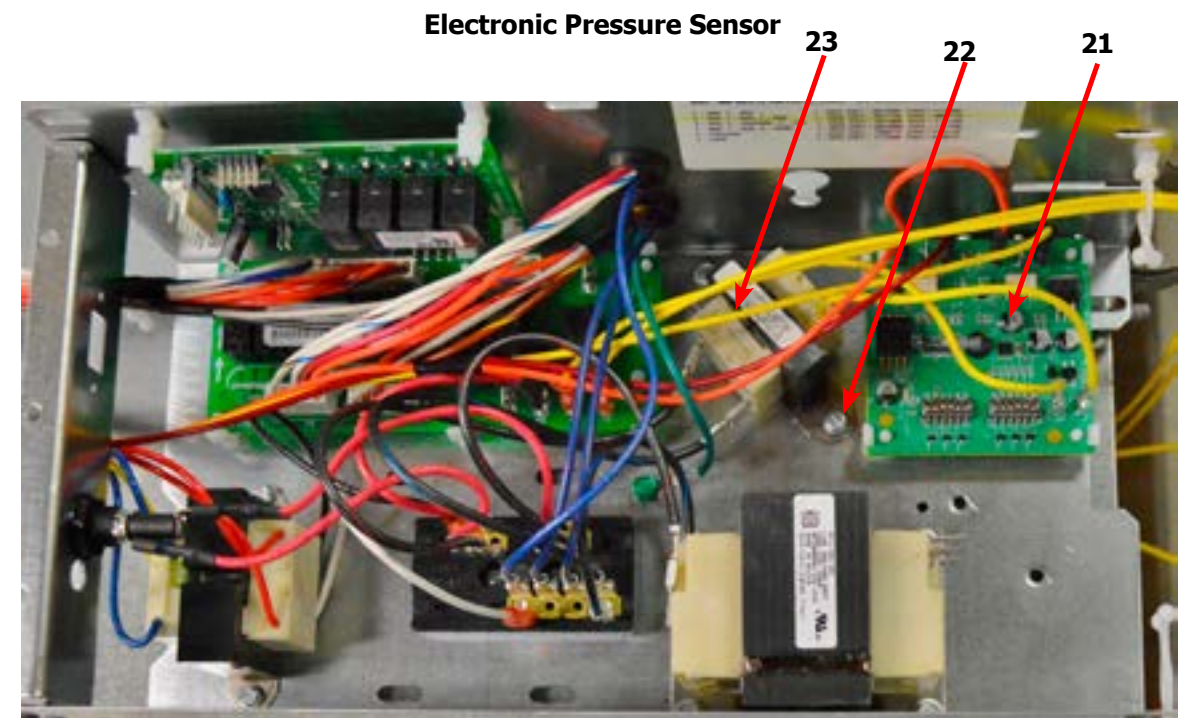
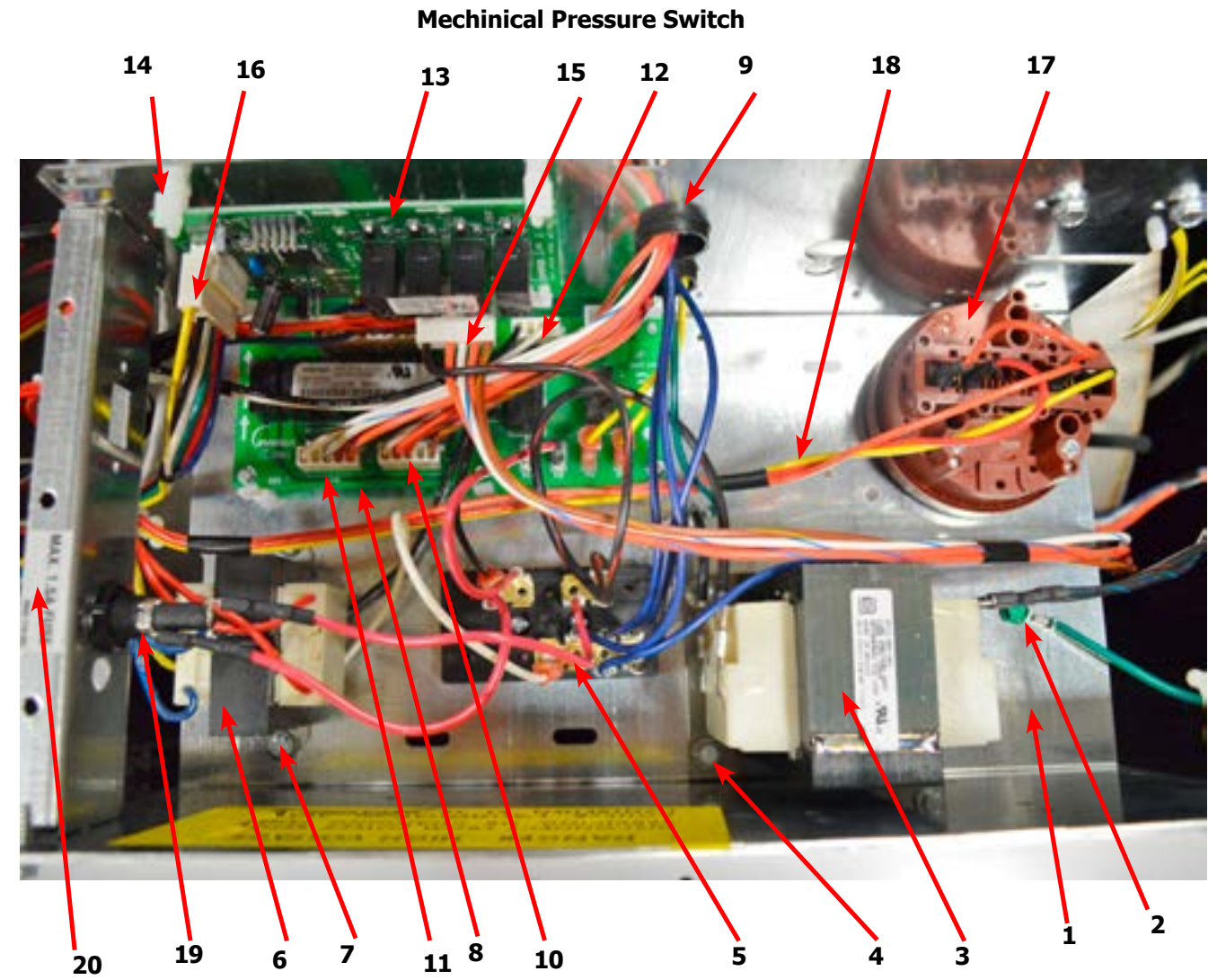

Control Panel Part # by Model

Key	Description	T650	T750	T950	T1450	QTY
1	Panel Control Assembly(panel only)	9989-479-001	9989-480-001	9989-480-001	9989-530-001	1
2	Nameplate,Control Panel (one piece) Black	9412-236-001	9412-223-001	9412-225-001	9412-230-001	1
*	Screw-Hxwshrhndunct #10Bx 1/2"(Control Panel To side Panel)	9545-008-026	9545-008-026	9545-008-026	9545-008-026	4
3	Plastic Shield over main PCB	9550-184-001	9550-184-001	9550-184-001	9550-184-001	1
4	Nut Hexkeps #8-32	8640-412-005	8640-412-005	8640-412-005	8640-412-005	3
5	Screw FillHDCR 10Bx1/2" Guide			9545-008-023	9545-008-023	1
6	Locator Panel			9355-001-001	9355-001-001	1
7	Plate -Latch, Top			9452-625-001	9452-625-001	2
8	Nut Hexkeps #8-32			8640-412-005	8640-412-005	4
9	Spacer Pushbutton (Micro)	9538-192-001	9538-192-001	9538-192-001	9538-192-001	1
10	Pushbutton Control (OPL), Black	9035-062-003	9035-062-003	9035-062-003	9035-062-003	1
11	Retainer Pushbutton (Micro)	9486-158-001	9486-158-001	9486-158-001	9486-158-001	1
12	Nut Hexelasticstop #4-40	8640-424-002	8640-424-002	8640-424-002	8640-424-002	2
13	Spacer Plastic #6x9/16	9538-157-022	9538-157-018	9538-157-018	9538-157-018	5
14	PCB assembly Control /Display	9473-004-010	9473-004-010	9473-004-010	9473-004-010	1
15	Nut Elasticstop #6-32	8640-411-002	8640-411-002	8640-411-002	8640-411-002	4
16	Nut Hexkeps #6-32	8640-411-003	8640-411-003	8640-411-003	8640-411-003	1
17	Spacer Plastic #6x9/16	9538-157-018	9538-157-018	9538-157-018	9538-157-018	2
18	PCB assembly Mode lights	9473-005-001	9473-005-001	9473-005-001	9473-005-001	1
19	Nut Hexkeps #6-32	8640-411-003	8640-411-003	8640-411-003	8640-411-003	2
20	Harness-LED PCB, P3	9627-797-001	9627-797-001	9627-797-001	9627-797-001	1
21	Spacer Plastic #6x9/16	9538-157-018	9538-157-018	9538-157-018	9538-157-018	2
22	Light, LED,ADD BLEACH Asembly	9794-001-001	9794-001-001	9794-001-001	9794-001-001	1
23	Nut Hexkeps #6-32	8640-411-003	8640-411-003	8640-411-003	8640-411-003	2
24	Lock-Run/Program, w/Harness & Key, P2	8650-027-001	8650-027-001	8650-027-001	8650-027-001	1
*	Key (N561)	6292-006-013	6292-006-013	6292-006-013	6292-006-013	AR
25	Actuator Assy-Door Locking, 120V	9892-015-001	9892-015-001	9892-015-001	9892-015-001	1
26	Nut Hexkeps #8-32	8640-412-005	8640-412-005	8640-412-005	8640-412-005	4
27	Nut-Spring	8640-399-008	8640-399-008	8640-399-008	8640-399-008	2
*	Screw FillHDCR 10Bx1/2" Guide	9545-008-023	9545-008-023			*
28	Bracket-Retainer, Front Panel			9029-191-001	9029-191-001	1
29	Screw FillHDCR 10Bx1/2" Guide			9545-008-023	9545-008-023	2
*	Harness-Optional relay, P23-P15	9627-798-001	9627-798-001	9627-798-001	9627-798-001	1
*	Harness-PCB to Relay, P8-P16	9627-794-001	9627-794-001	9627-794-001	9627-794-001	1
*	Harness-Door Lock, P4	9627-791-004	9627-791-005	9627-791-005	9627-791-005	1
*	Harness-PCB to Enable, P20-P21	9627-793-001	9627-793-001	9627-793-001	9627-793-001	1
*	Transformer-120V/24/5.3, P7	8711-009-001	8711-009-001	8711-009-001	8711-009-001	1
*	Harness-Pressure Switch, P5	9627-806-001	9627-807-001	9627-807-001	9627-899-001	1

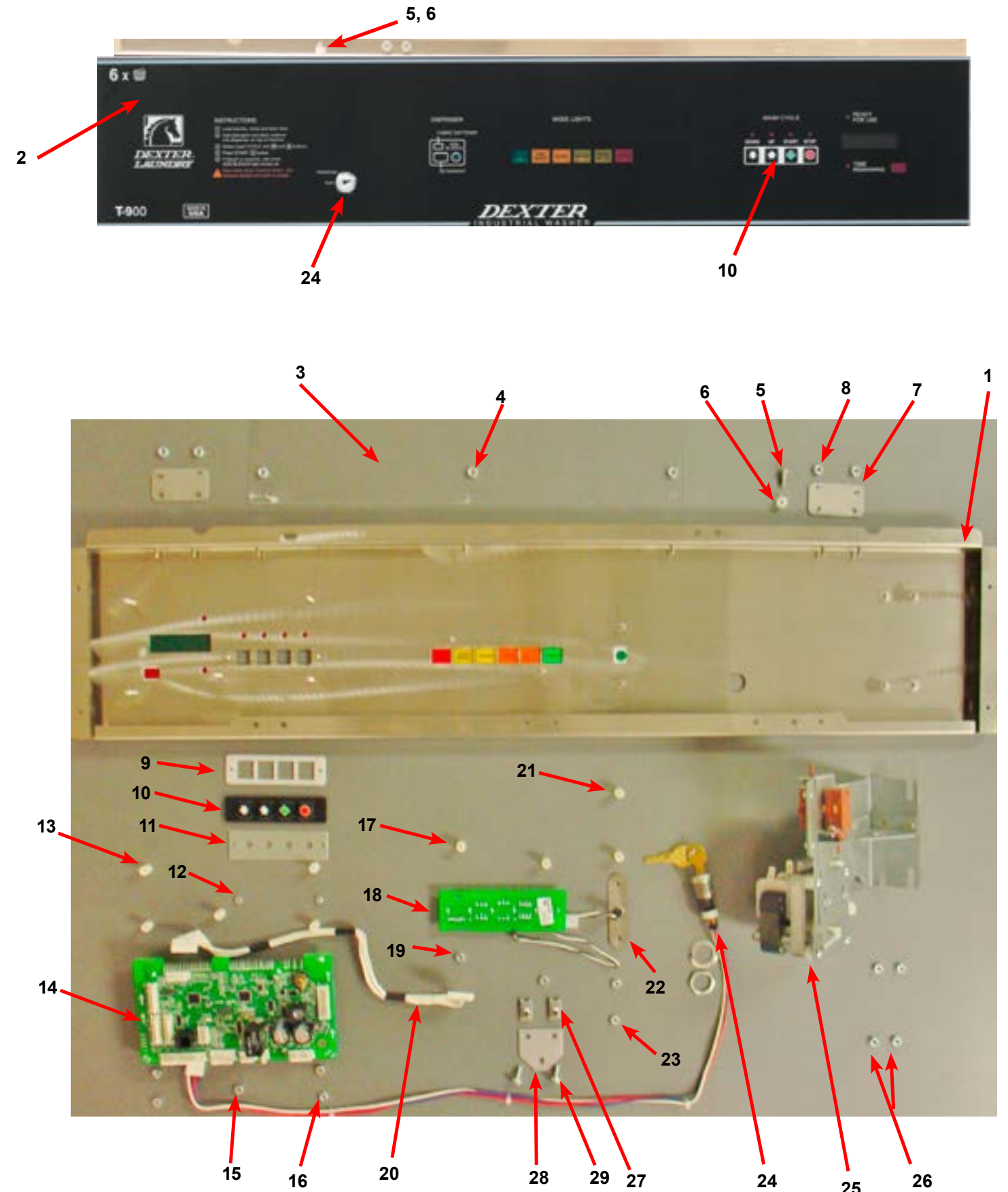

Labels and Diagrams All C-Series Models

Key	Description	T650	T750	T950	T1450	QTY
*	Operators Manual	8514-257-001	8514-242-001	8514-243-001	8514-247-001	1
	Wiring Schematic & Diagram	9506-708-001	9506-556-001	9506-560	9506-564-001	1
*	Transient Voltage Surge Suppressor Infomational	8507-330-001	8507-330-001	8507-330-001	8507-330-001	1
*	Instructions Spin Direction	8507-275-001	8507-275-001	8507-275-001	8507-275-001	1
*	Label High Voltage Warning	8502-614-004	8502-614-004	8502-614-004	8502-614-004	1
*	Label Fusing & Installation	8502-619-004	8502-619-003	8502-619-003	8502-619-003	1
*	Label Quality	8511-001-002	8511-001-002	8511-001-002	8511-001-002	1
1	Label Warning Risk of Injury (Black)	8502-759-001	8502-759-001	8502-759-001	8502-759-001	1
2	Label Warning Door Opening (Black)	8502-757-001	8502-757-001	8502-757-001	8502-757-001	1
3	Label Dispenser (Black)	8502-745-001	8502-745-001	8502-745-001	8502-745-001	1
	Label, Injector Assembly	8502-666-001	8502-666-001	8502-666-001	8502-666-001	1

Notes



Risk of Injury Label



Top Dispenser Label Front Soap Dish



Door Label

Transformer, Electrical Filter -39 models

Wn0750-XA39	230 volts	50hz	Single Phase
Wn0900-XA39	230 volts	50hz.	Single Phase
WN0950-XA39	230 volts	50hz.	Single Phase
WN01200-XA39	230 volts	50hz	Single Phase
WN01450-XA39	230 volts	50hz	Single Phase

Key	Component	T650	T750	T950	T1450	QTY
1	Circuit Breaker	5198-211-002	5198-211-002	5198-211-002	5198-211-002	1
*	Instructions, Transformer Connect	8507-449-002	8507-449-002	8507-449-002	8507-449-002	1
*	Manual-Opeators	8514-228-002	8514-			1
2	Controls Transformer, 200/250-24V 50Hz.	8711-004-003	8711-004-003	8711-004-003	8711-004-003	1
	Water Valve	9379-183-013	9379-183-013	9379-183-013	9379-183-013	2
	Diaphragm Invensys (EPDM)	9118-049-001	9118-049-001	9118-049-001	9118-049-001	2
	Diaphragm Invensys (Viton)	9118-049-002	9118-049-002	9118-049-002	9118-049-002	2
	Water Valve Single			9379-194-003	9379-194-003	2
	Diaphragm Mueller			9118-055-001	9118-055-001	1
	Wiring Label , Schematic & Diagram	9506-534-001	9506-536-001	9506-538-001	9506-541-001	1
	Wiring Harness, Power Terminal Block	9627-747-006	9627-747-006	9627-747-006	9627-747-006	1
	Wiring Harness Main, 1.5	9627-914-001	9627-914-001	9627-914-001	9627-914-001	1
	Hose Assembly, Inlet	9990-027-014				

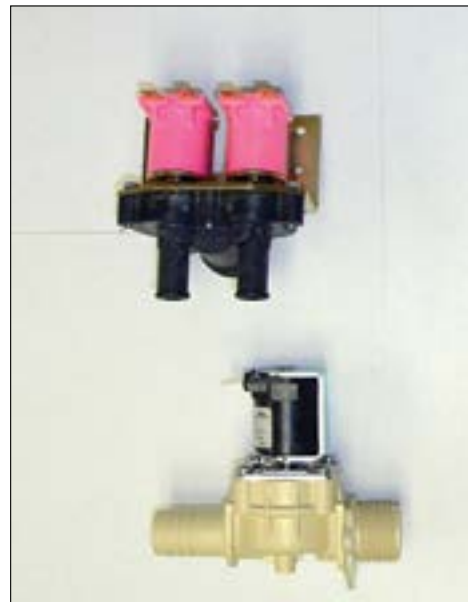

Drain Valve Group Part 50 HZ

Key	Description	Part Number	Qty
1	Valve, Drain (includes #2 thru #11)	9379-202-002	1
2	Body, Valve (w/ball)	9064-072-001	1
3	Motor & Gear Train (complete)	9914-137-022	1
4	Plate, Motor Mtg	9452-538-001	1
5	Screw	8639-994-001	1
6	Spring, Drive	9534-339-001	1
7	Screw	9545-054-001	1
8	Screw	9545-054-002	1
9	Seal, V Packer	9532-134-001	1
10	Washer	8641-584-001	1
11	Pin, Main Drive	9451-196-001	1
*	Plate (spacers needed for replacement motor mtg. plate)	9538-149-001	1
12	Kit - Seal Replacement	9732-327-001	1

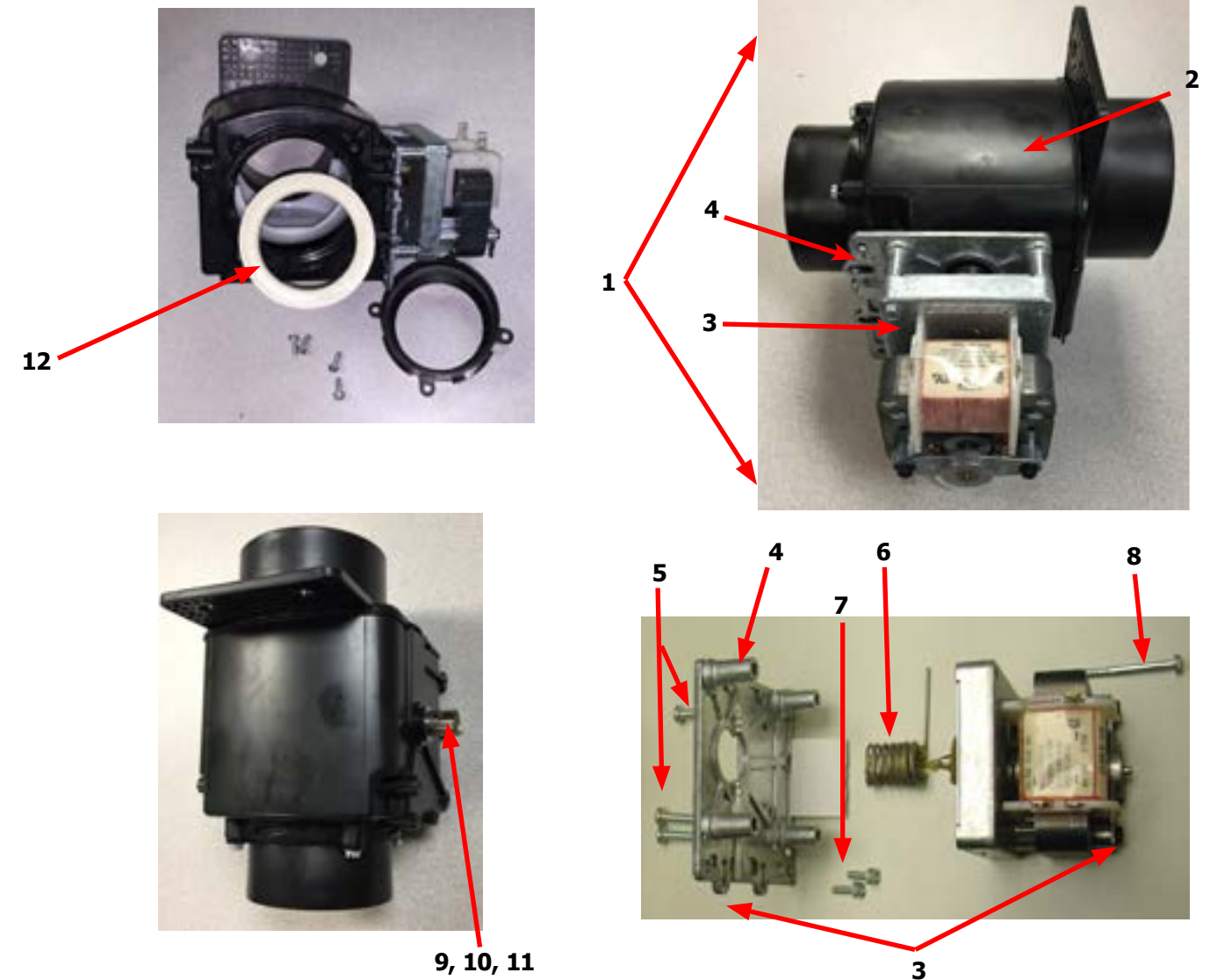

T-750-39 Schematic

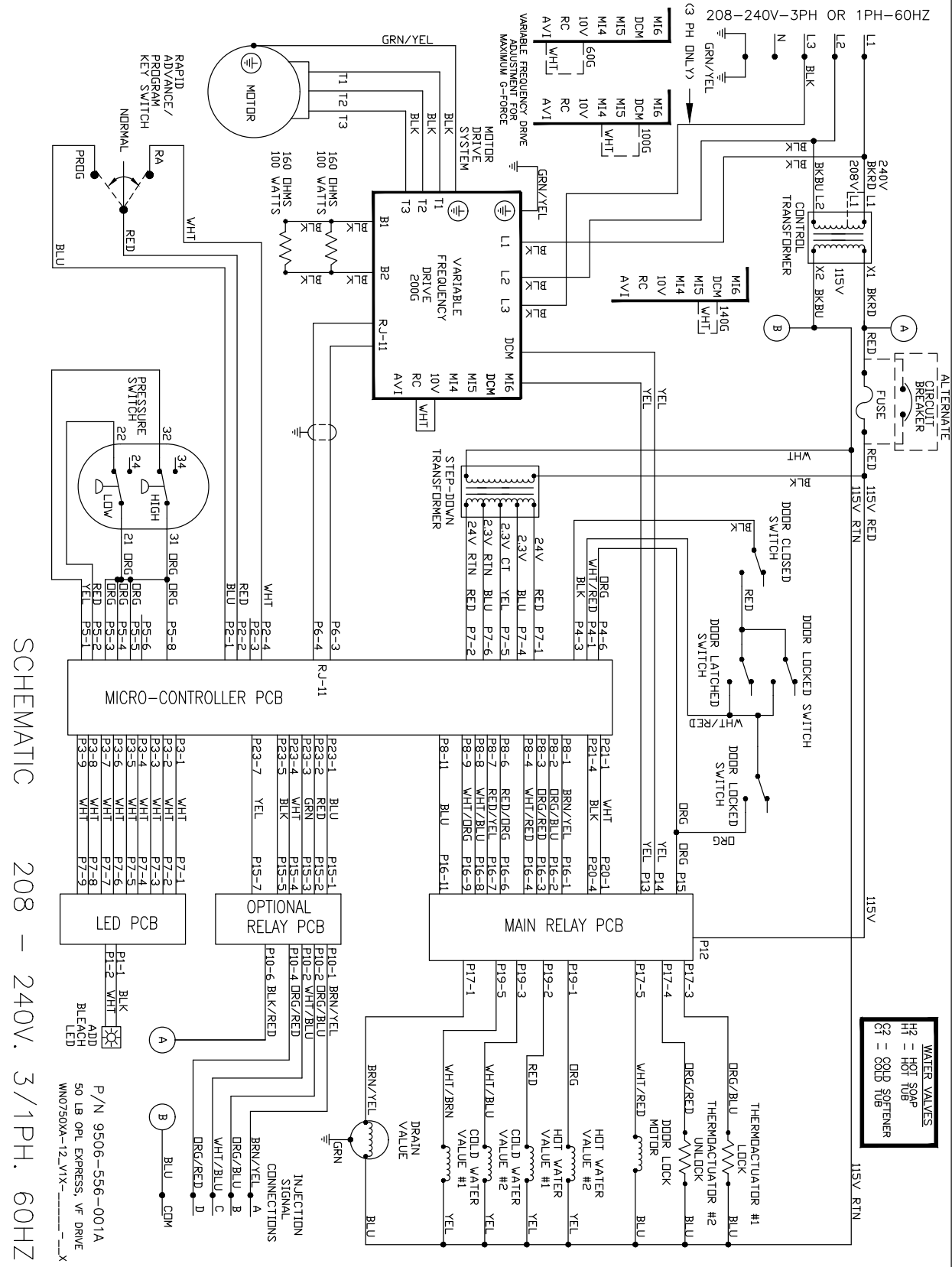

SCHEMATIC 208 - 240V, 3/1PH, 60HZ

P/N 9506-556-001A
 50 LB OPL EXPRESS, VF DRIVE
 WND750XA-12-V1X-____X

T-750-39 Diagram

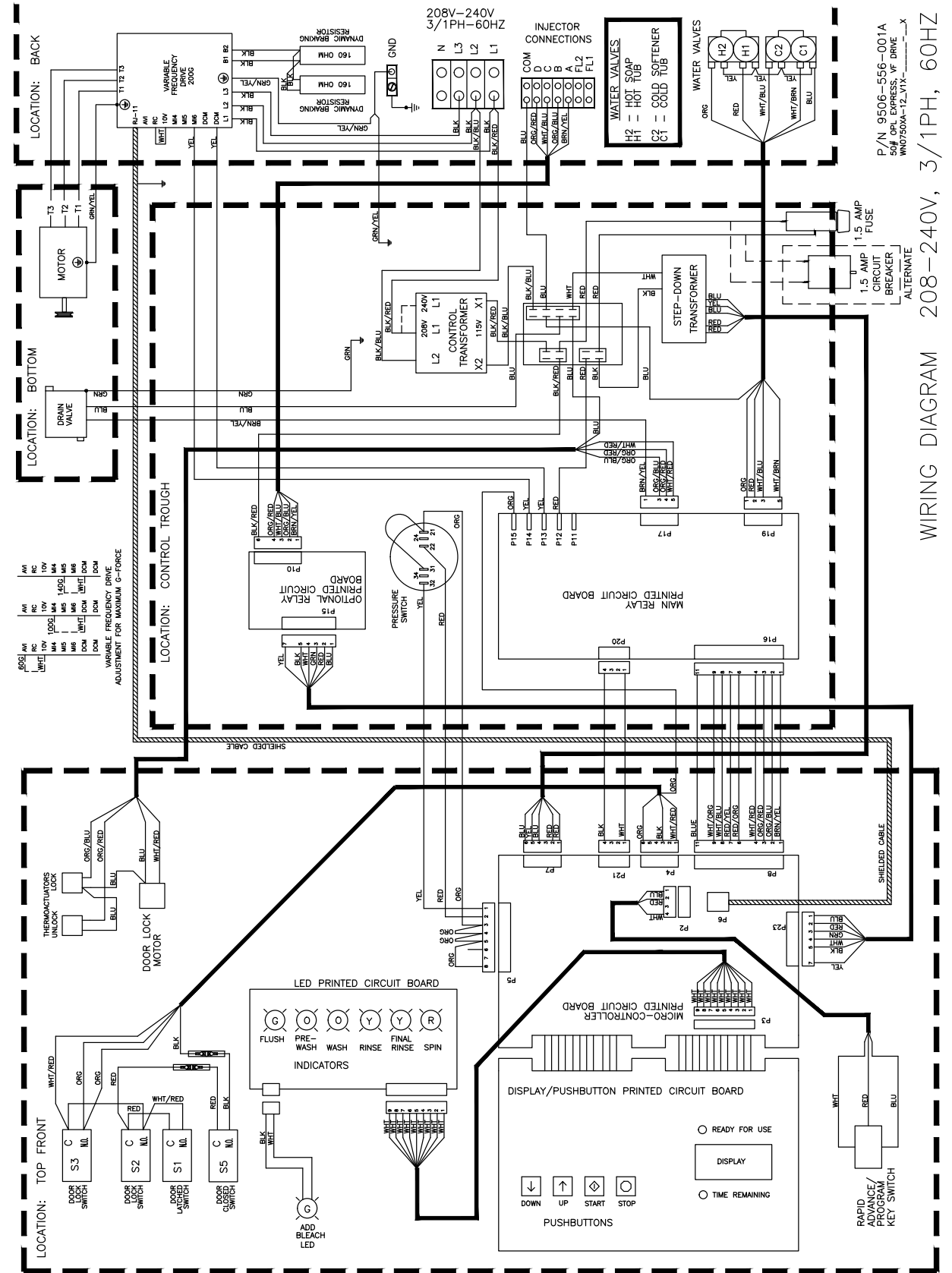

WIRING DIAGRAM 208-240V, 3/1PH, 60HZ

P/N 9506-556-001A
 50# OPL EXPRESS, VF DRIVE
 WND750XA-12-V1X-____X

T-950-39 Schematic

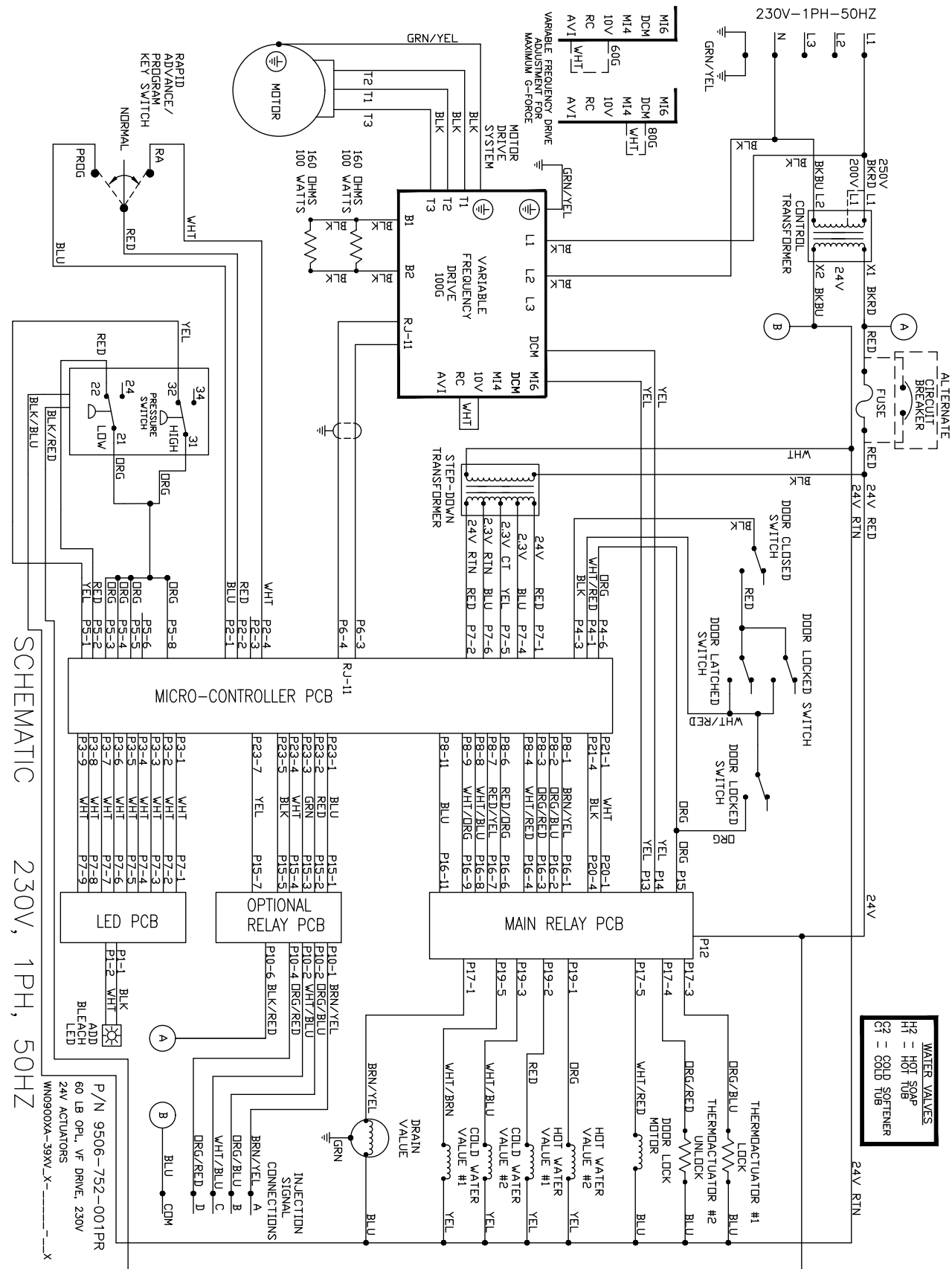

T-950-39 Diagram

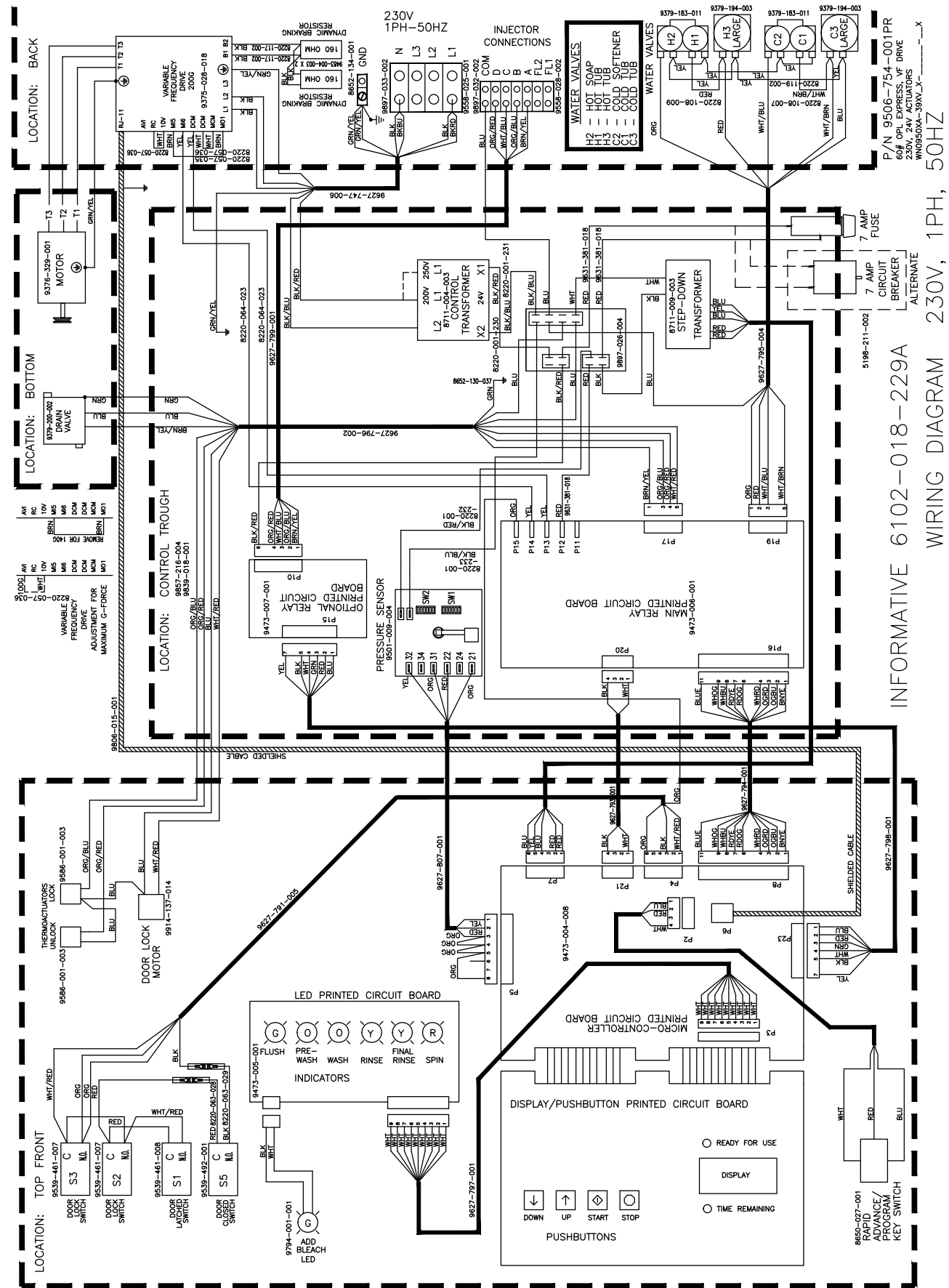

T-950-39 Schematic V4

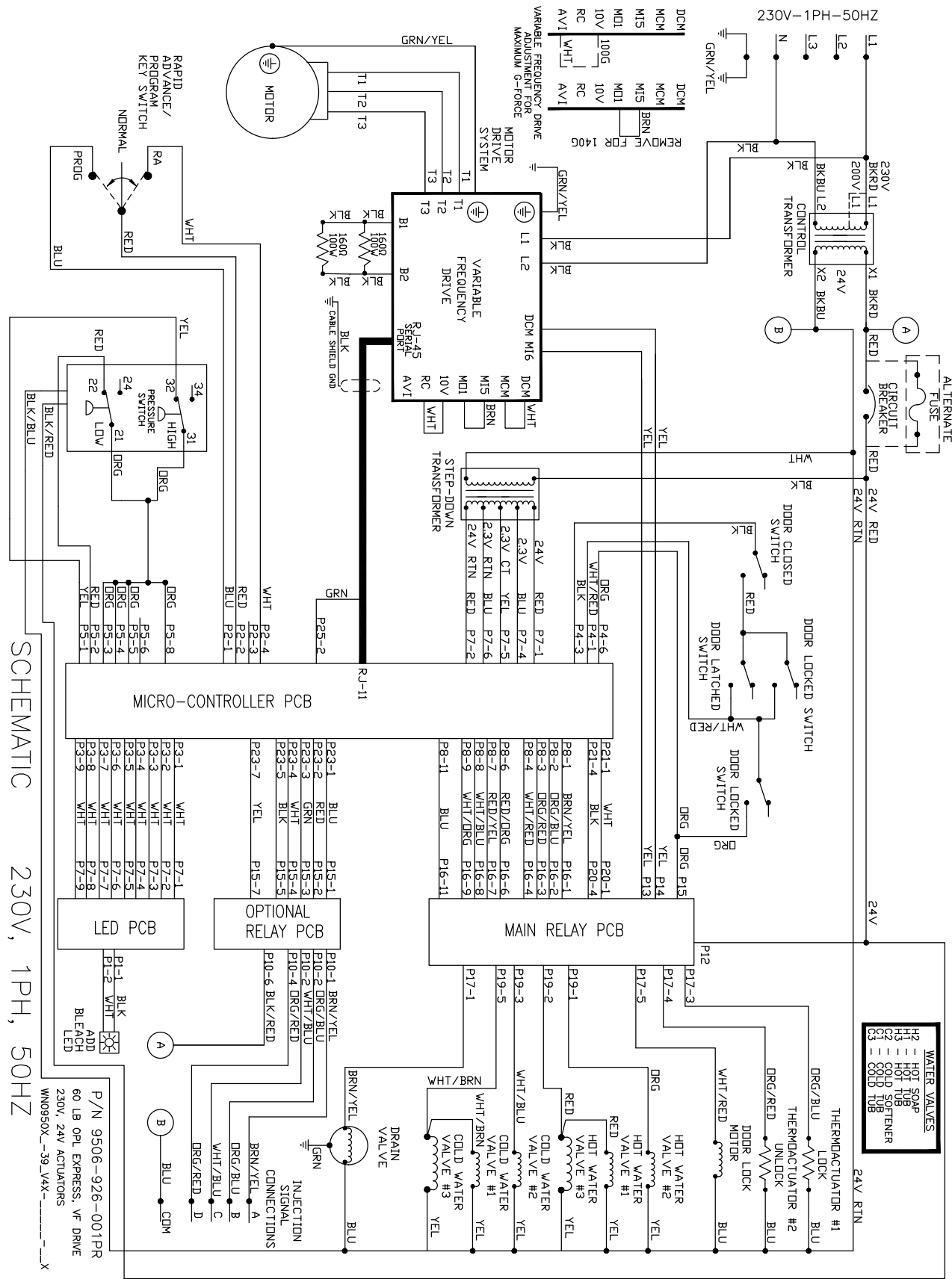

T-950-39 Diagram V4

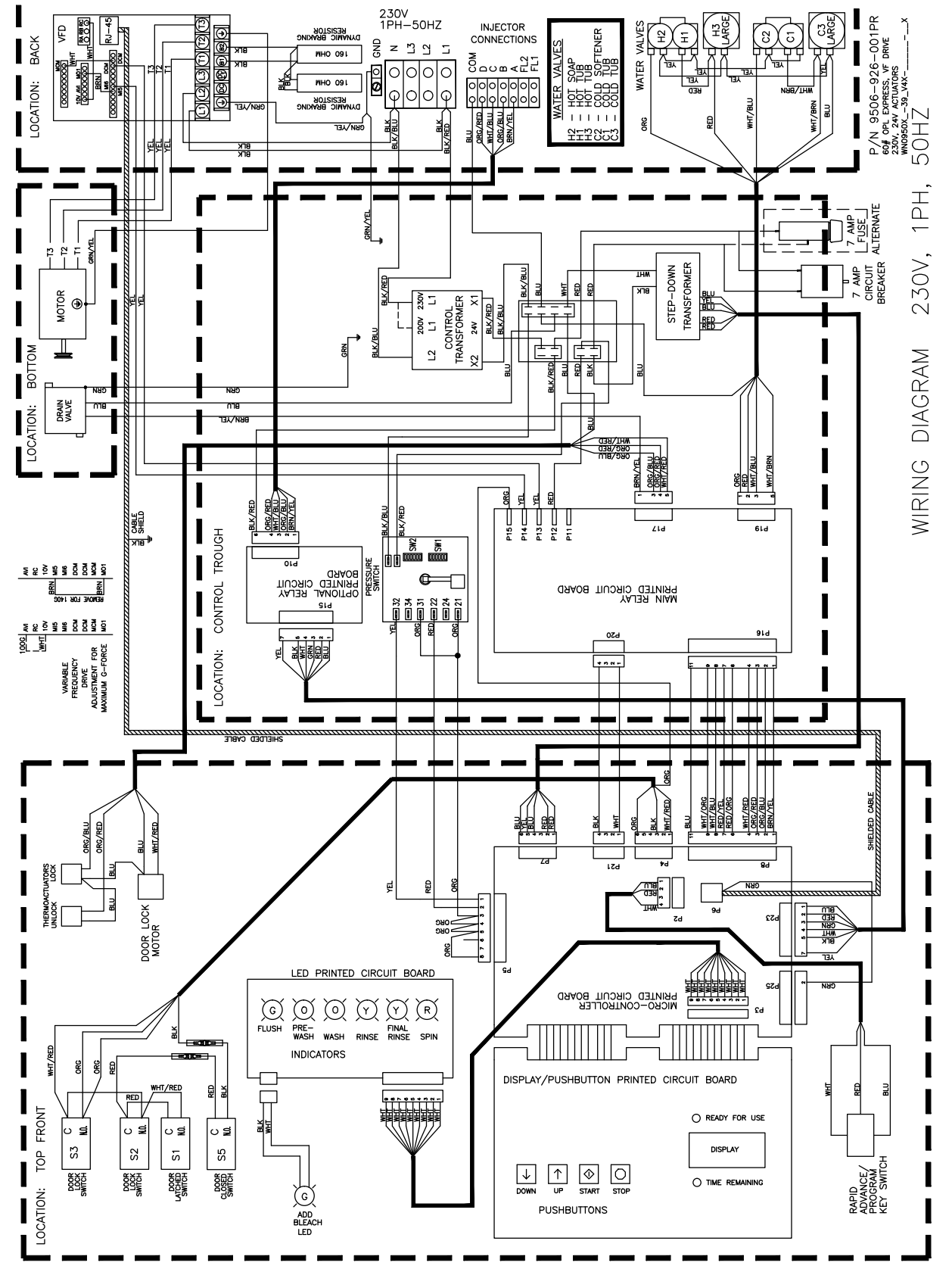

WIRING DIAGRAM 230V, 1PH, 50HZ

T-1450-39 Schematic

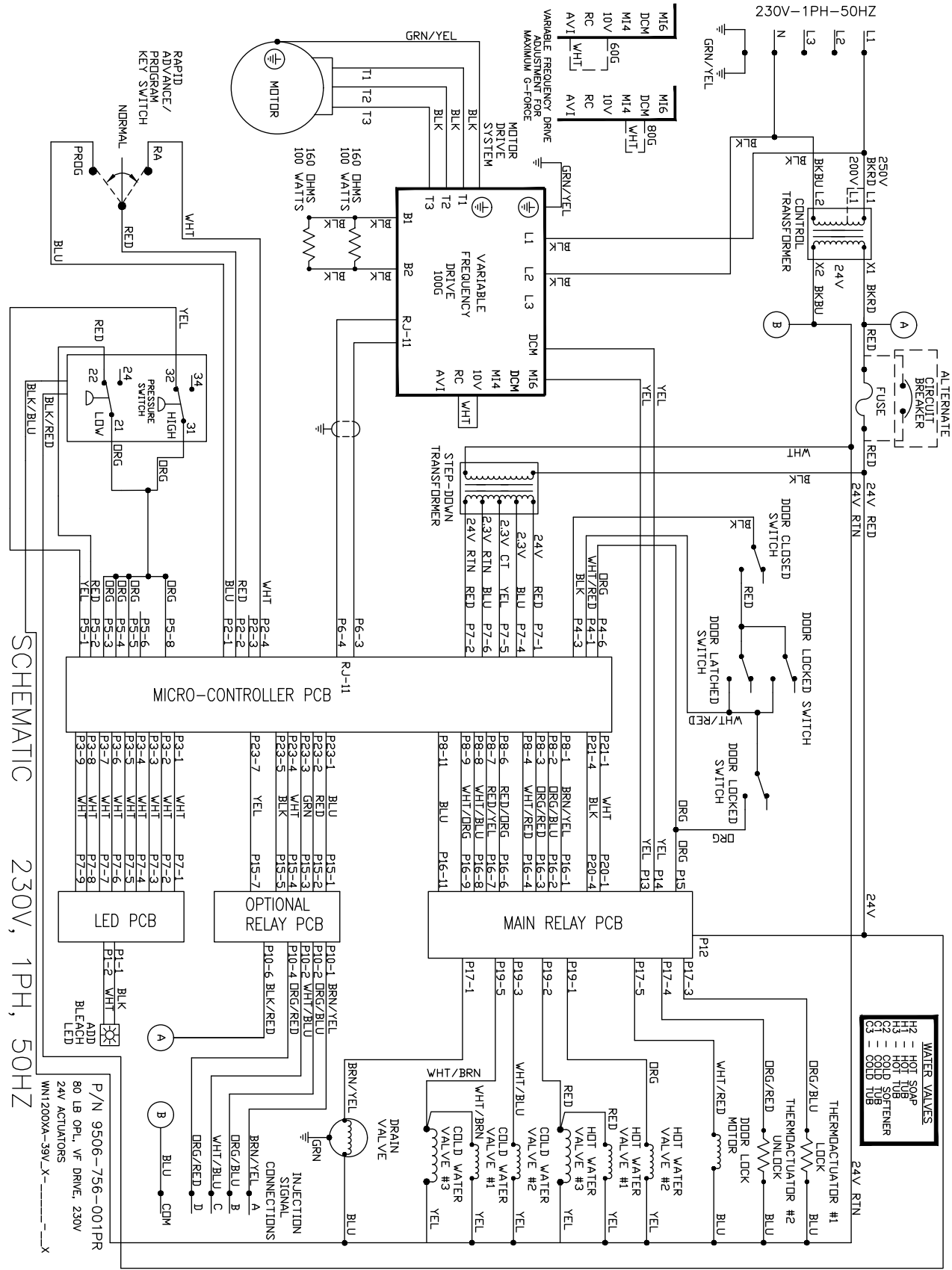

T-1450-39 Diagram

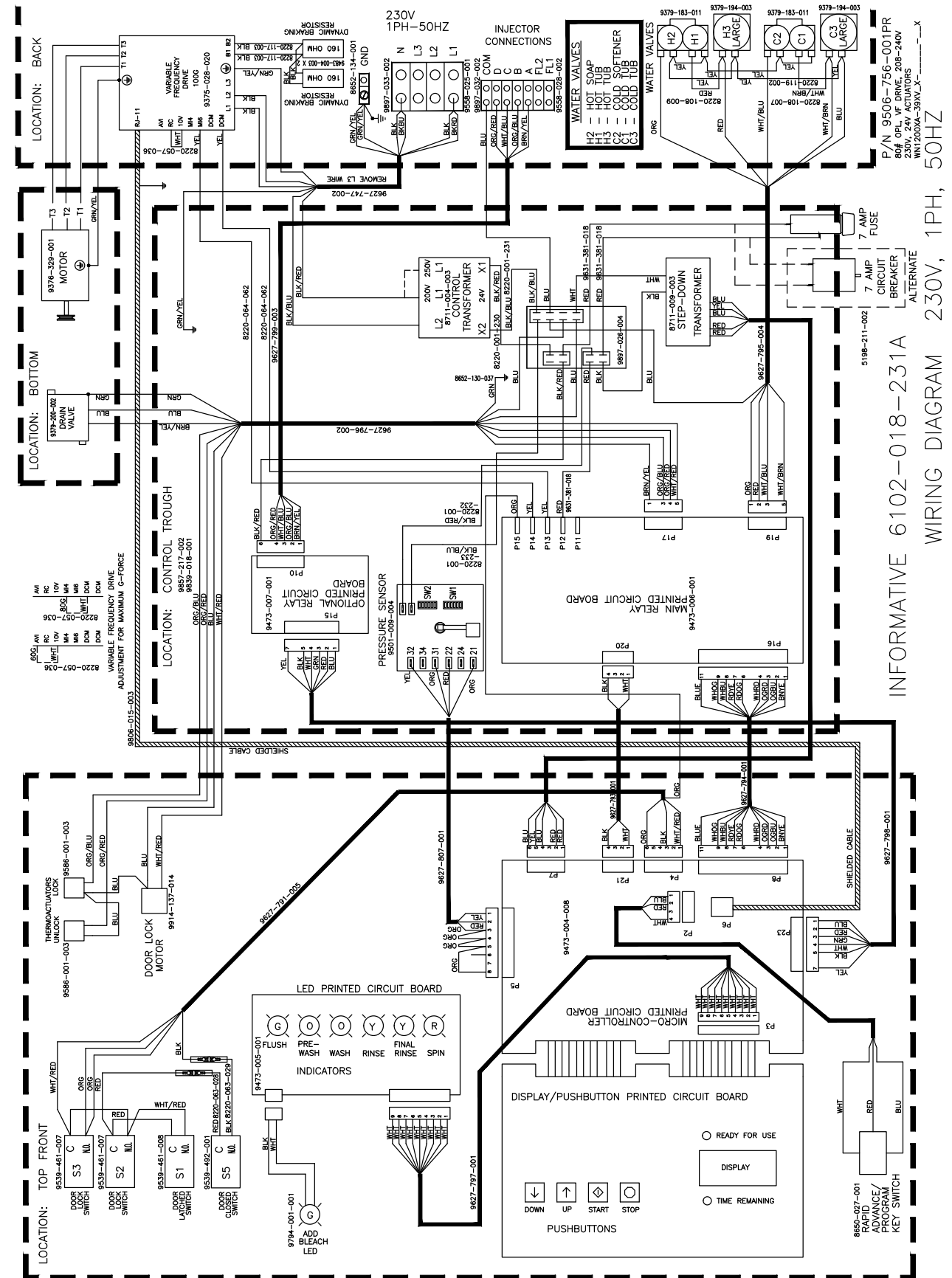

CE -59 models

Key	Component	T650	QTY
*	Circuit Breaker	5198-211-002	1
*	Strio, Terminal Marker	9558-025-001	1
*	Manual-Operators	8514-301-001	1
*	Controls Transformer, 200/250-24V 50Hz.	8711-004-004	1
*	Instructions, Transformer Connect	8507-449-004	1
*	Water Valve	9379-183-013	2
*	Diaphragm Invensys (EPDM)	9118-049-001	2
*	Diaphragm Invensys (Viton)	9118-049-002	2
*	Wiring Label , Schematic & Diagram	9506-953-001	1
*	EMI Filter	9183-053-001	1
*	Line Reactor	9477-002-001	1
*	Do Not Enter/Confined Space Warning Label	8502-748-001	1
*	Do Not Operate w/ Gear Label	8502-748-003	2
*	Do Not Operate w/out Gear Label	8502-748-004	2
*	Elec. Shock Warning Label	8502-748-005	2
*	Explosive Material Warning Label	8502-748-006	1
*	Flammable Material Warning Label	8502-748-007	1
*	Lockout Warning Label	8502-748-008	1
*	Read Manual Warning Label	8502-748-009	2
*	Emergency Stop Label	8502-765-001	1
*	Wiring Schematic/Diagram Label	9506-938-001	1

T-650 -59 Schematic

