



DEXTER[®]
LAUNDRY

**USE THE BLUE TABS LOCATED ON THE
RIGHT AND LEFT SIDES OF THE FOLLOWING
DOCUMENT TO ADVANCE TO EACH SECTION.**

Kits, Assemblies, & Common Parts

Loading Door & Door Lock Components	Part Number
Door Glass Gasket (Standard Door)	9206-419-001
Door Glass Gasket (Small Door)	9206-411-002
Door Handle Only (Large)	9244-091-001
Door Close Switch	9539-492-001
Door Lock Gear Motor Assembly	9922-015-001
Kit - Door Latching Assy. & Cam (replaces original Door Latching Assembly)	9732-347-001
Kit - Door Cam Replacement	9732-346-002
Kit - Locking Pawl Replacement	9732-346-001
Kit - Door Gasket Expander Kit (Small)	9732-139-001
Kit - Door Gasket Expander Kit (Large)	9732-139-002
Electrical Components	Part Number
Transformer, Main	8711-004-001
Transformer, Control	8711-009-004
Main Control Board	9473-004-010
Kit-Replacement, Pressure Sensor (Only)	9732-315-001
VFD & Breaking Resistors Components	Part Number
Breaking Resistor 200 Ohms	9483-004-002
Breaking Resistor 160 Ohms	9483-004-003
Delta E Drive Display	9150-044-001
MS 300 VFD Display	9150-058-001
Data Cable (56")	9806-015-003
Drain & Water Valve Components	Part Number
Kit - 3" Drain Valve Seal Replacement	9732-327-001
Drain Valve 3"	9379-202-001
Drain Valve 2"	9379-199-001
Water Valve (Dual)	9379-183-012
Diaphragm (Dual)	9118-049-003
Cabinet Components	Part Number
Front Panel Screw	9545-008-014
Front Panel Finisher Washer	8641-585-001
Front Panel Spring Nut	8640-399-008
Top Soap Box Screw (Regular Chassis Only)	9545-008-012
Top Soap Box Spring Nut (Regular Chassis Only)	8640-399-007
5/16 Hex Screw, Common	9545-008-026
Top Lock Key #6324	9306-025-001
Cylinder Plug (1.5" Plastic)	9456-041-007



Section 8: Parts Data:

T300	WN0300XA-10EV	120 volts	60hz.	Single Phase
T300	WN0300XA-12EV	208-240 volts	60hz.	Single Phase or Three Phase
T350	WN0350XA-12EV	208-240 volts	60hz	Single Phase or Three Phase
T400	WN0400XA-12EV	208-240 volts	60hz	Single Phase or Three Phase
T450	WN0450XA-12EV	208-240-volts	60hz	Single Phase or Three Phase
T600	WN0600XA-12EV	208-240 volts	60 hz	Single Phase or Three Phase

Cabinet and Front Panel Group Part # by Model

Key	Description	T-300	T-350	T-400	T-450	T-600	QTY
1	Panel, Side (Left or Right) - stainless			9732-359-006	9732-359-007	9732-359-008	2
*	Panel, Right Side-stainless	9989-639-001	9989-640-001				1
1	Panel, Left Side - stainless	9989-639-002	9989-640-002				1
*	Screw, (Side Panel to Base)	9545-018-018	9545-018-018	9545-018-013	9545-018-013		6
*	Screw, (Side Panel to Base)					9545-018-013	8
*	Nut, Hex 1/4-20 UNC	8640-414-006	8640-414-006	8640-414-006	8640-414-006		6
*	Nut, Hex 1/4-20 UNC					8640-414-006	8
*	Pad-Foam, Side Panel	0904-904-001	0904-904-001	0904-904-001	0904-904-001	0904-904-001	2
*	Bracket, Side Panel under front panel	9029-263-001	9029-263-001	9029-263-001	9029-263-001	9029-263-001	1
*	Nut, Hex (to tub front)	8640-413-002	8640-413-002	8640-413-002	8640-413-002	8640-413-002	2
*	Screw, #10B x 1/2	9545-008-026	9545-008-026	9545-008-026	9545-008-026	9545-008-026	2
2	Panel, Control	9989-477-001	9989-477-001	9989-478-001	9989-478-001	9989-479-001	1
*	Screw, Control Panel to Sides	9545-008-026	9545-008-026	9545-008-026	9545-008-026	9545-008-026	4
*	Nut, Expansion	8640-442-001	8640-442-001	8640-442-001	8640-442-001	8640-442-001	4
3	Nameplate Decal, Control Panel (Black)	9412-217-001	9412-218-001	9412-219-001	9412-220-001	9412-221-001	1
4	Button, Push (Black)	9035-060-004	9035-060-004	9035-060-004	9035-060-004	9035-060-004	1
5	Panel Assy, Front	9454-893-002	9454-893-002	9454-894-002	9454-894-002	9454-895-002	1
*	Trim, Edge Protector	9578-092-005	9578-092-005	9578-092-005	9578-092-005	9578-092-005	1
*	Screw, Hex- To Control Panel	9545-008-031	9545-008-031	9545-008-031	9545-008-031	9545-008-031	2
*	Nut, Spring- To Control Panel 10/32	8640-442-001	8640-442-001	8640-442-001	8640-442-001	8640-442-001	2
6	Screw, Flat Head- Front to Sides	9545-008-014	9545-008-014	9545-008-014	9545-008-014	9545-008-014	2
7	Washer, Finish	8641-585-001	8641-585-001	8641-585-001	8641-585-001	8641-585-001	2
*	Nut, Spring-To Front Panel	8640-442-001	8640-442-001	8640-442-001	8640-442-001	8640-442-001	2
8	Label, Warning-Door Opening (Black)	8502-757-001	8502-757-001	8502-757-001	8502-757-001	8502-757-001	1
9	Label, Warning-Door Risk of Injury (Black)	8502-759-001	8502-759-001	8502-759-001	8502-759-001	8502-759-001	1
10	Door, Lower Service (includes handle & Rivits)	9960-286-001	9960-286-001	9960-286-002	9960-286-002	9960-286-002	1
11	Handle (bumper guard)	9244-086-001	9244-086-001	9244-086-002	9244-086-002	9244-086-002	1
*	Rivet	9491-009-003	9491-009-003	9491-009-003	9491-009-003	9491-009-003	4
12	Screw Mtg., Flat Head	9545-008-023	9545-008-023	9545-008-014	9545-008-014	9545-008-014	2
13	Washer, Finish	8641-585-001	8641-585-001	8641-585-001	8641-585-001	8641-585-001	2
*	Nut, Spring	8640-442-001	8640-442-001	8640-442-001	8640-442-001	8640-442-001	2
14	Plug- 1 1/2" (Tubback Bearing housing bolt access)	9456-041-007	9456-041-007	9456-041-007	9456-041-007	9456-041-007	1
15	Lock, Top (w/Key)	8650-012-003	8650-012-003	8650-012-003	8650-012-003	8650-012-003	1
*	Lock Spacer	9538-189-001	9538-189-001	9538-189-001	9538-189-001	9538-189-001	*
*	Key, Top- # 6324	6292-006-007	6292-006-007	6292-006-007	6292-006-007	6292-006-007	1
16	Bumper-Loading door	9051-055-001	9051-055-001	9051-055-001	9051-055-001	9051-055-001	1
*	Nut, 1/4-20 UNC, 2B	8640-414-006	8640-414-006	8640-414-006	8640-414-006	8640-414-006	1

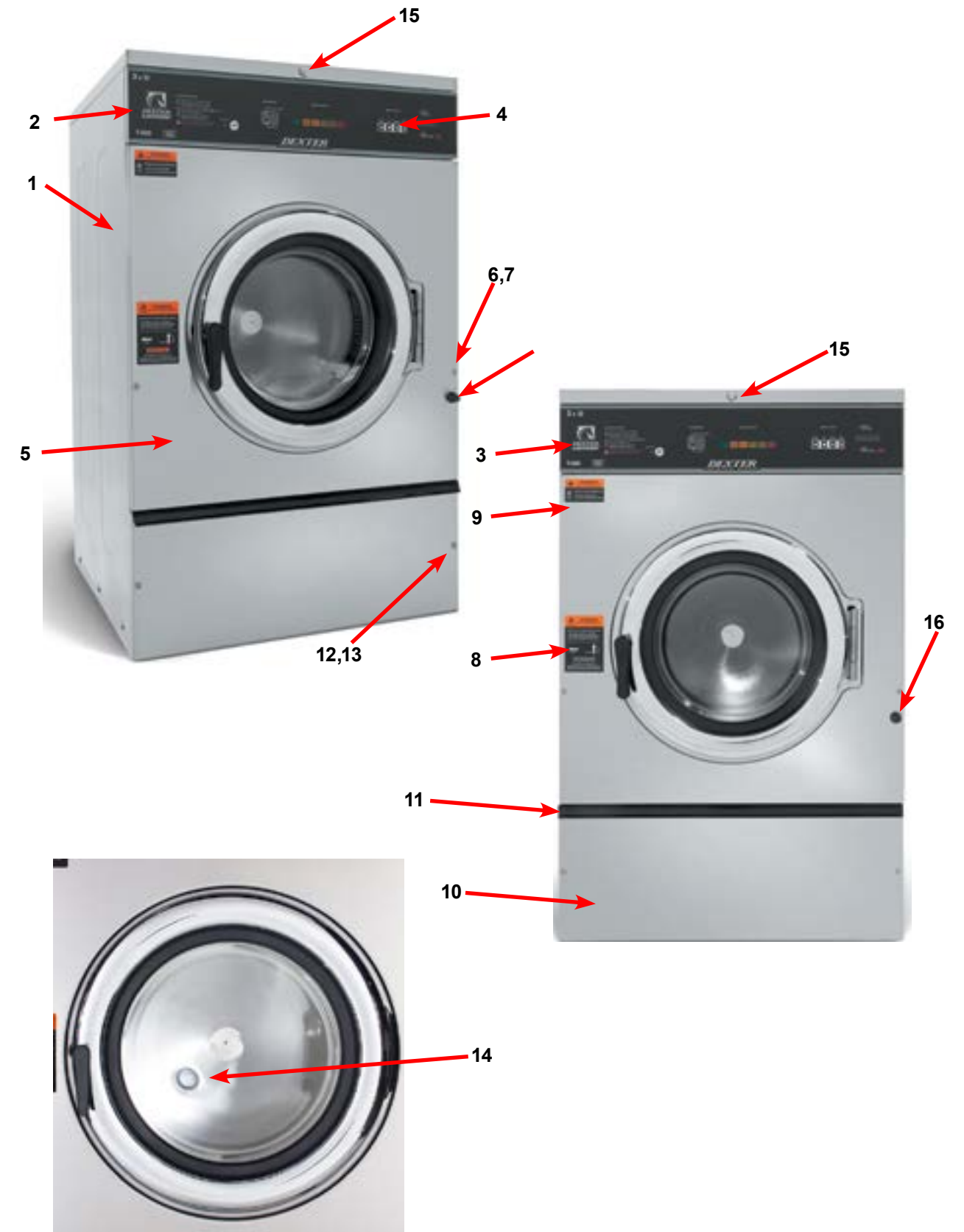

Rear View Access Part # by Model

Key	Description	T-300	T-350	T-400	T-450	T-600	QTY
1	Drive Motor, 3 Phase (Inverter duty) W/Pulley	9732-225-001	9732-227-001	9732-127-012	9732-127-014	9732-127-012	1
2	Pulley, Motor	9453-169-012	9453-169-012	9453-170-003	9453-181-001	9453-170-003	1
*	Set Screw,Sq.Hd(motor pulley)	9545-028-015	9545-028-015	9545-028-015	9545-028-015	9545-028-015	2
3	Rod, Motor Mtg	9497-222-002	9497-222-002	9497-222-002	9497-222-002	9497-222-004	1
*	Screw (end of motor rod)	9545-029-005	9545-029-005	9545-029-005	9545-029-005	9545-029-005	1
*	Lockwasher (end of motor rod)	8641-582-014	8641-582-014	8641-582-014	8641-582-014	8641-582-014	1
4	Motor Bushing (Rubber)	9053-082-001	9053-082-001	9053-082-001	9053-082-001	9053-082-001	2
5	Clamp-Worm, 316SS, 1.5" (for Rubber bushing)	8654-117-019	8654-117-019	8654-117-019	8654-117-019	8654-117-019	2
6	Strap Bracket, Motor Tension	9029-206-002	9029-206-002	9029-206-002	9029-206-002	9029-206-002	1
*	Nut, Strap to Motor 10/32 UNF	8640-413-002	8640-413-002	8640-413-002	8640-413-002	8640-413-002	1
*	Washer #10	8641-581-006	8641-581-006	8641-581-006	8641-581-006	8641-581-006	1
7	Spring, Belt Tension	9534-319-002	9534-319-002	9534-319-002	9534-319-002	9534-319-002	1
8	Pulley, Driven	9908-041-002	9453-168-005	9453-168-004	9453-168-006	9453-168-003	1
*	Tolerance Ring (Driven Pulley)	9487-234-002	9487-234-001	9487-234-001	9487-234-003	9487-234-003	1
9	Screw 1/2-13x1 1/4"	9545-017-009	9545-017-009	9545-017-009			1
9	Screw 5/8-11x1 1/2" Driven pulley				9545-060-001	9545-060-001	1
10	Lockwasher 1/2"	8641-582-016	8641-582-016	8641-582-016			1
10	Lockwasher 5/8"				8641-582-018	8641-582-018	1
11	Washer, Flat 1/2"	8641-581-026	8641-581-026	8641-581-026			1
11	Washer, Flat 5/8x2 1/4"				8641-581-032	8641-581-032	1
12	Drive Belt	9040-076-004	9040-079-004		9040-079-005		1
12	Drive Belt			9040-076-005		9040-076-005	2
*	Hose, Overflow Vent Top	9242-463-001	9242-463-002	9242-463-002	9242-463-003	9242-463-003	1
*	Clamp, Hose Vent	8654-117-008	8654-117-008	8654-117-008	8654-117-008	8654-117-008	1
13	Hose, Overflow to drain	9242-449-002	9242-449-002	9242-449-002	9242-449-002	9242-449-002	1
*	Clamp, Hose overflow to drain	8654-117-018	8654-117-018	8654-117-018	8654-117-018	8654-117-018	2
14	Hose, Pressure Switch	9242-175-000	9242-175-000	9242-175-007	9242-175-007	9242-175-001	1
*	Clamp, Pressure Switch Hose	8654-117-015	8654-117-015	8654-117-015	8654-117-015	8654-117-015	1
	Vacuum Breaker Mtg Bracket	9029-266-001	9029-266-001	9029-078-001	9029-077-001	9029-077-001	1
*	Vacuum Breaker ALL	9610-001-001	9610-001-001	9610-001-001	9610-001-001	9610-001-001	1
*	Clamp, Hose to Vacuum Breaker	8654-117-014	8654-117-008	8654-117-008	8654-117-014	8654-117-014	1
*	Hose, Vacuum Breaker to tub	9242-458-001	9242-458-001				1
*	Hose, Vacume Breaker to Injector			9242-461-001	9242-461-001	9242-461-001	1
*	Clamps			8654-117-014	8654-117-014	8654-117-014	1
*	Clip - Hose Tie Back			9083-114-001	9083-114-001		*
*	Strap Tie, Adjustable Ratchet			9544-040-001	9544-040-001		*

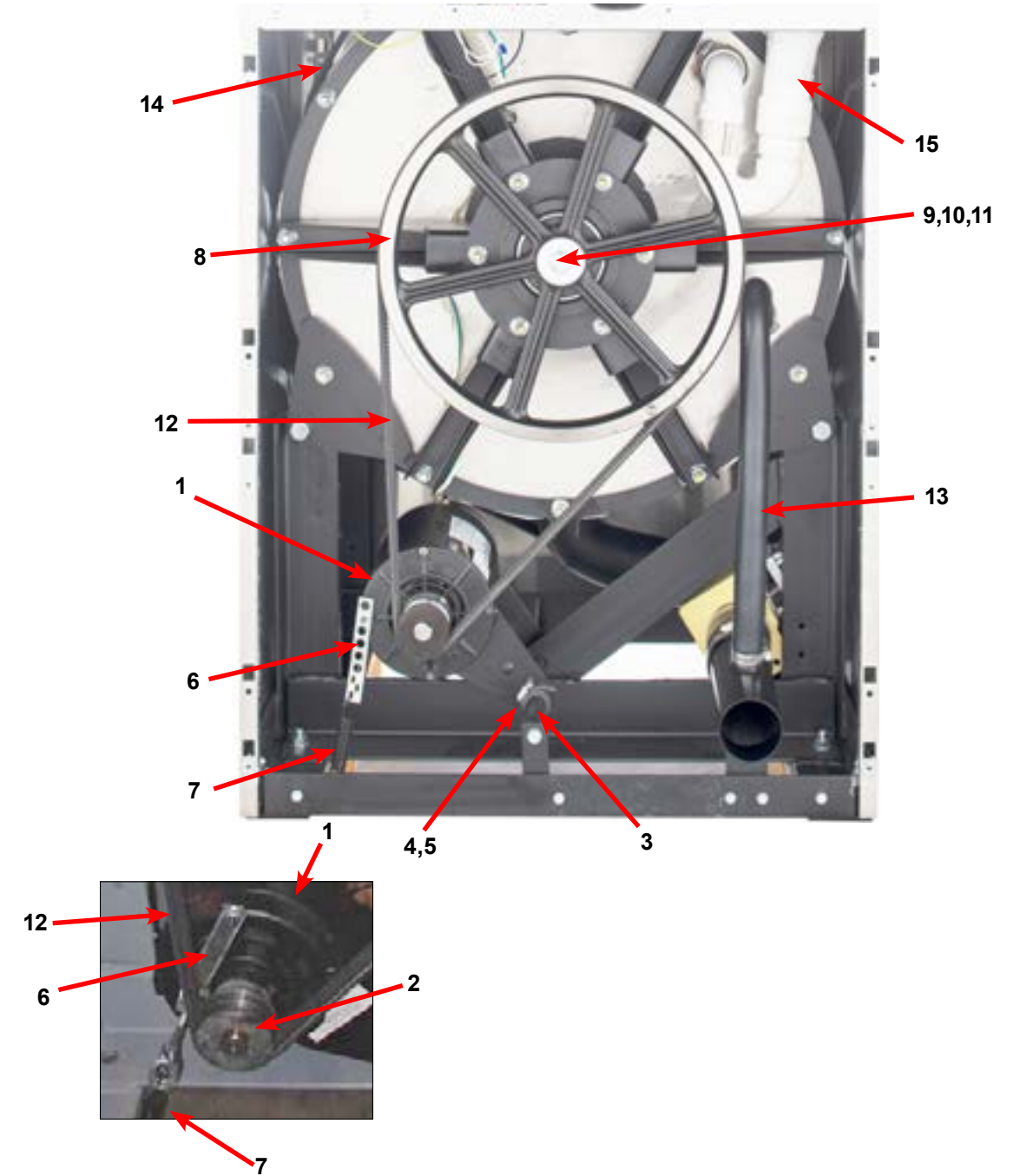

Key	Description	T-300	T-350	T-400	T-450	T-600	QTY
15	Injector Assembly, Soap			9883-006-001	9883-010-001	9883-009-001	1
*	Hose, Injector to Tub Back			9242-462-001	9242-462-001	9242-462-001	1
*	Clamps			8654-117-014	8654-117-014	8654-117-014	1
*	Cap-Injector Assy			0935-127-001	0935-127-001	0935-127-001	1
*	Clamp			9242-117-014	9242-117-014	9242-117-014	1
*	Panel Assy., Back	9454-632-001	9454-632-001	9989-562-001	9989-562-001	9989-562-001	1
*	Screw Panel Mtg.#10x1/2"	9545-008-026	9545-008-026	9545-008-026	9545-008-026	9545-008-026	10
*	Nut, Spring	8640-399-004	8640-399-004	8640-399-004	8640-399-004	8640-399-004	6
*	Screw, To Base-1/4x3/4	9545-030-002	9545-030-002	9545-030-002	9545-030-002	9545-030-002	1

Key	Description	T-300	T-350	T-400	T-450	T-600	QTY
1	Channel, Rear	9947-025-001	9947-025-001	9947-026-001	9947-026-001	9947-026-001	1
2	Screw #10Bx1/2	9545-008-026	9545-008-026	9545-008-026	9545-008-026	9545-008-026	4
*	Nut, Spring	8640-399-007	8640-399-007	8640-399-007	8640-399-007	8640-399-007	4
3	Plug, 7/8"	9456-041-006	9456-041-006	9456-041-006	9456-041-006	9456-041-006	1
4	Bushing, 7/8"	9053-067-002	9053-067-002	9053-067-002	9053-067-002	9053-067-002	1
5	Braacket-Terminal Block Assy	9029-265-001	9029-265-001	9029-265-001	9029-265-001	9029-265-001	1
6	Screw, 10Bx1/2	9545-008-026	9545-008-026	9545-008-026	9545-008-026	9545-008-026	4
7	Strip-Terminal marker, Power			9558-025-001	9558-025-001	9558-025-001	1
8	Terminal Block-Power			9897-033-002	9897-033-002	9897-033-002	1
*	Screw-6ABx3/4			9545-031-010	9545-031-010	9545-031-010	2
9	Harness-Power Terminal Block			9627-747-003	9627-747-003	9627-747-003	1
10	Terrminal Lug, Solderless			8652-134-001	8652-134-001	8652-134-001	1
*	Lockwasher-Exttooth, #10			8641-582-006	8641-582-006	8641-582-006	1
11	Screw-10-32ttX1x1/2Grn			9545-008-027	9545-008-027	9545-008-027	2
12	Strip-Terminal Marking, Injector	9558-028-001	9558-028-001	9558-028-001	9558-028-001	9558-028-001	1
13	Terminal Block-Injector	9897-032-002	9897-032-002	9897-032-002	9897-032-002	9897-032-002	1
*	Screw-4Bx5/8ss	9545-053-002	9545-053-002	9545-053-002	9545-053-002	9545-053-002	2
14	Harness-Injection	9627-799-001	9627-799-001	9627-799-001	9627-799-003	9627-799-002	1
15	Label-Warning	8502-639-001	8502-639-001	8502-639-001	8502-639-001	8502-639-001	1
16	Bushing-Insulated, 3/4"	9053-067-001	9053-067-001	9053-067-001	9053-067-001	9053-067-001	1
17	Bushing-Insulated, 1"	9053-067-004	9053-067-004	9053-067-004	9053-067-004	9053-067-004	1
*	Cover, Terminal Block	9074-267-001	9074-267-001	9074-267-001	9074-267-001	9074-267-001	1
*	Screw #10Bx1/2	9545-008-026	9545-008-026	9545-008-026	9545-008-026	9545-008-026	1
18	Plate Drive Mounting	9982-382-001	9982-382-001	9982-382-001	9982-382-001	9982-382-001	1
19	Nut-#10-32UNF, 2B	8640-413-002	8640-413-002	8640-413-002	8640-413-002	8640-413-002	4
20	VFD Delta "E" drive 208-240 volt	9375-032-007	9375-032-005	9375-030-005			1
20	VFD Delta "E" drive 120 volt	9375-031-005					
*	Cable, Data	9806-015-001	9806-015-001	9806-015-001	9806-015-001	9806-015-001	1
*	VFD Cooling Fan	9189-013-001	9189-013-001	9189-013-001	9189-013-001	9189-013-001	1
21	Nut-#10-32UNF 2B	8640-413-002	8640-413-002	8640-413-002	8640-413-002	8640-413-002	4
*	VFD "MS300" V4 -10	9375-033-007					1
*	VFD Cooling Fan	9189-016-001					
*	VFD "MS300" V4	9375-034-009	9375-034-010	9375-035-011	9375-035-012	9375-035-014	1
*	VFD Cooling Fan	9189-015-001	9189-015-001	9189-016-001	9189-016-001	9189-016-001	1
*	Data Cable "MS300" V4	9806-026-001	9806-026-001	9806-026-001	9806-026-001	9806-026-001	1
22	Mounting Plate Water Valves	9452-813-001	9452-813-001	9452-813-001	9452-813-001	9452-813-001	1
23	Nut-Elastic stop, #10-32	8640-413-002	8640-413-002	8640-413-002	8640-413-002	8640-413-002	2
24	Valve-Water, Duel Coil	9379-183-010	9379-183-010	9379-183-010	9379-183-010	9379-183-010	2
25	Screw #10Bx1/2	9545-008-026	9545-008-026	9545-008-026	9545-008-026	9545-008-026	4
26	Shield over Water Valves Plastic	9550-194-001	9550-194-001	9550-194-001	9550-194-001	9550-194-001	1
27	Push Clip	9083-121-001	9083-121-001	9083-121-001	9083-121-001	9083-121-001	3
28	Vacuum Breaker	9610-001-001	9610-001-001	9610-001-001	9610-001-001	9610-001-001	1
*	Bracket-Vacuum Breaker	9029-266-001	9029-266-001	9029-078-001	9029-077-001	9029-077-001	1
*	Vacuum Breaker Cap (Red)	0935-135-002	0935-135-002	0935-135-002	0935-135-002	0935-135-002	*
29	Screw, 10Bx1/2	9545-008-026	9545-008-026	9545-008-026	9545-008-026	9545-008-026	4
30	Cap-Injector Assy		0935-127-001	0935-127-001	0935-127-001	0935-127-001	1
*	Clamp		9242-117-014	9242-117-014	9242-117-014	9242-117-014	1
31	Hose, Vacume Breaker to Injector			9242-461-001	9242-461-001	9242-461-001	1

Rear View Access Part # by Model Continued

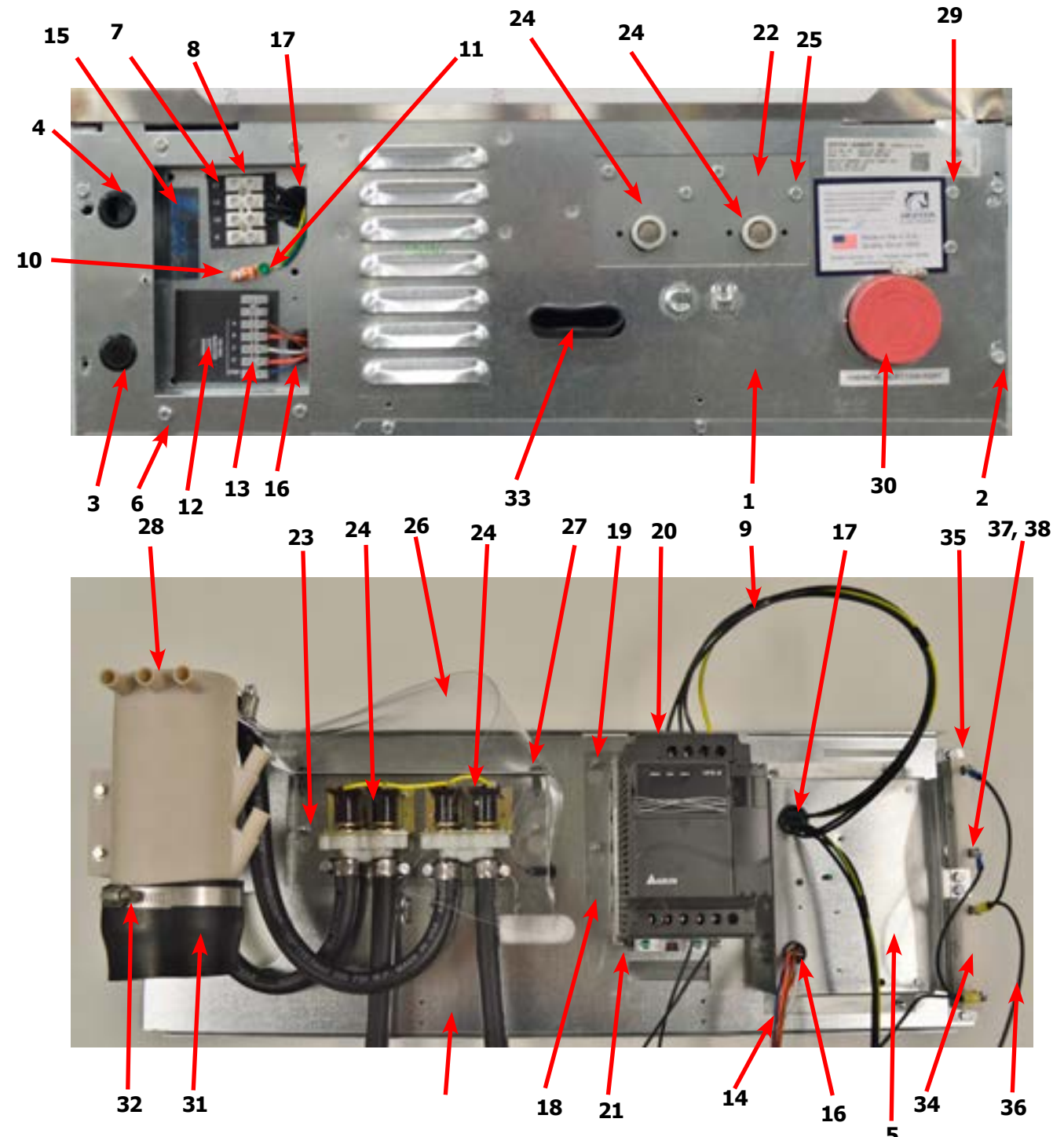

32	Clamps			8654-117-014	8654-117-014	8654-117-014	1
33	Hose-Suds Overflow	9242-463-001	9242-463-002	9242-463-002	9242-463-003	9242-463-003	1
34	Braking resistors (200 ohm) (-10)	9483-004-002					1
34	Braking resistors (200 ohm)	9483-004-002	9483-004-002	9483-004-002	9483-004-002	9483-004-002	2
35	Screw-#10Bx1/2	9545-008-026	9545-008-026	9545-008-026	9545-008-026	9545-008-026	4
*	Wire Assy -Violet, (24" T300-10)	8220-118-001	N/A	N/A	N/A	N/A	2
36	Wire Assy, Jumper	8220-117-002	8220-117-002	8220-117-002	8220-117-002	8220-117-002	2
37	Screw, #6-32x5/16	9545-044-006	9545-044-006	9545-044-006	9545-044-006	9545-044-006	4
38	Nut, #6-32	8640-411-003	8640-411-003	8640-411-003	8640-411-003	8640-411-003	4

Cylinder, Seals & Bearings Part # by Model

Key	Description	T-300	T-350	T-400	T-450	T-600	QTY
*	Bearing and Seal Kit	9732-219-001	9732-219-008	9732-219-003	9732-219-005	9732-219-005	1
*	Housing, Bearing- Assembly (items #2-#6)	9803-182-001	9803-179-003	9803-179-002	9803-186-001	9803-186-001	1
2	Housing, Bearing	9241-174-002	9241-169-002	9241-169-002	9241-180-002	9241-180-002	1
3	Bearing, Front (LARGE)	9036-159-001	9036-159-009	9036-159-002	9036-159-005	9036-159-005	1
4	Bearing, Rear (SMALL)	9036-159-003	9036-159-008	9036-159-001	9036-159-004	9036-159-004	1
5	Spacer, Bearing	9538-161-001	9538-158-001	9538-158-001	9538-167-001	9538-167-001	1
6	Ring, Bearing Retainer	9487-238-002	9487-238-001	9487-238-001	9487-238-003	9487-238-003	1
7	Tub Back Mating Ring	9487-261-001	9487-261-002	9487-261-002	9487-261-003	9487-261-003	1
8	Seal, Large	9532-140-010	9532-140-009	9532-140-009	9532-140-009	9532-140-009	1
9	Seal, Small	9532-140-005	9532-140-003	9532-140-003	9532-140-006	9532-140-006	1
10	Ring, Seal Mounting	9950-047-001	9950-042-001	9950-042-001	9950-048-001	9950-048-001	1
11	Back Assy, Tub 2 piece	9732-137-001	9732-137-002	9732-137-002	9732-137-003	9732-137-003	1
12	Bolt, Tub End of Bearing Housing (1/2" x 1 1/4")	9545-017-009	9545-017-009	9545-017-009			6
12	Nut 1/2'	8640-417-005	8640-417-005	8640-417-005			6
12	Lockwasher 1/2" (ext. tooth)	8641-581-034	8641-581-034	8641-582-016			6
12	Bolt 7/16-14x1 1/2" Tub end of bearing housing				9545-059-003	9545-059-003	6
12	Nut 5/8"				8640-425-001	8640-425-001	6
13	Support Arm Assy, Bearing Housing	9991-049-002	9991-057-002	9991-061-002	9991-056-002	9991-056-002	6
*	Tub Alignment Spacer	9552-038-003	9552-038-003	9552-038-003	9552-038-003	9552-038-003	
14	Bolt Pulley End of Bearing Housing (3/8" x 1 1/2")	9545-029-003	9545-029-003	9545-029-003			6
14	Nut, Flange Locking 3/8"	8640-415-004	8640-415-004	8640-415-004			6
14	Bolt Pulley end of bearing housing (7/16-14x2")				9545-059-002	9545-059-002	6
14	Nut, Flange Locking 7/16"				8640-416-005	8640-416-005	6
15	Pulley, Driven	9908-041-002	9453-168-005	9453-168-004	9453-168-006	9453-168-003	1
*	Ring, Tolerance	9487-234-002	9487-234-001	9487-234-001	9487-234-003	9487-234-003	1
16	Washer 1/2"	8641-581-026	8641-581-026	8641-581-026			1
16	Washer 5/8"				8641-581-032	8641-581-032	1
18	Bolt 1/2-13 x 1 1/4"	9545-017-009	9545-017-009	9545-017-009			1
18	Bolt 5/8-11x11/2"				9545-060-001	9545-060-001	1
20	Lockwasher 1/2" Ext. tooth	8641-582-016	8641-582-016	8641-582-016			1
18	Lockwasher 5/8 Ext. tooth				8641-582-018	8641-582-018	1
*	Cylinder Assy Before Serial # W1.20190.XXX	9732-354-001	9732-354-002	9732-354-003	9732-354-004	9732-354-006	1
*	Cylinder Assy After Serial # W1.20190.XXX	9848-163-001	9848-164-001	9845-165-001	9848-166-001	9848-168-001	1
*	Tub and Cylinder Assy.	9869-028-001	9869-029-001	9869-030-001	9869-031-001	9869-032-001	1
*	Tub Assembly	9930-159-001	9930-160-001	9930-161-001	9930-162-001	9930-163-001	1

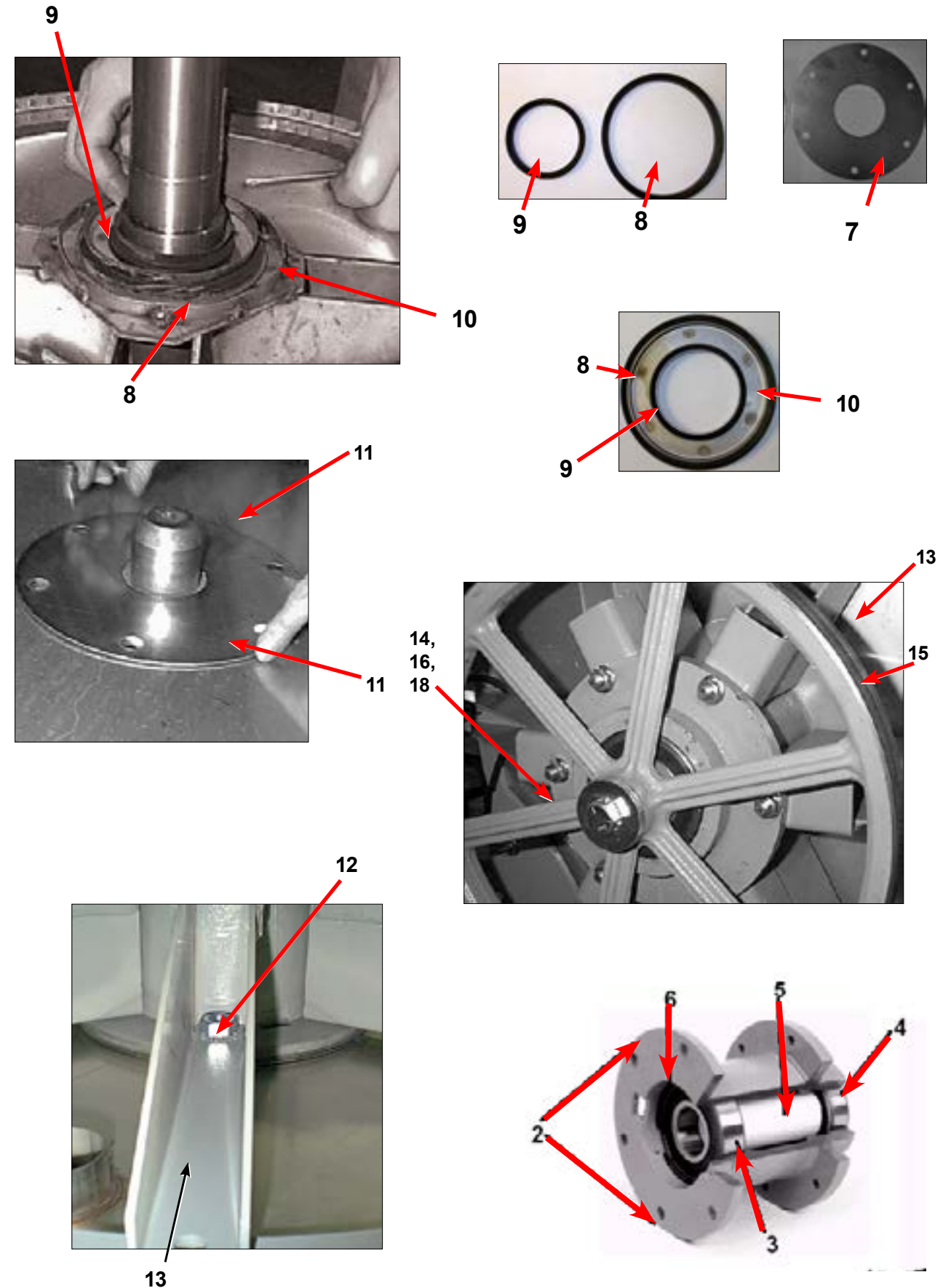

Door Lock Assembly (All Models)

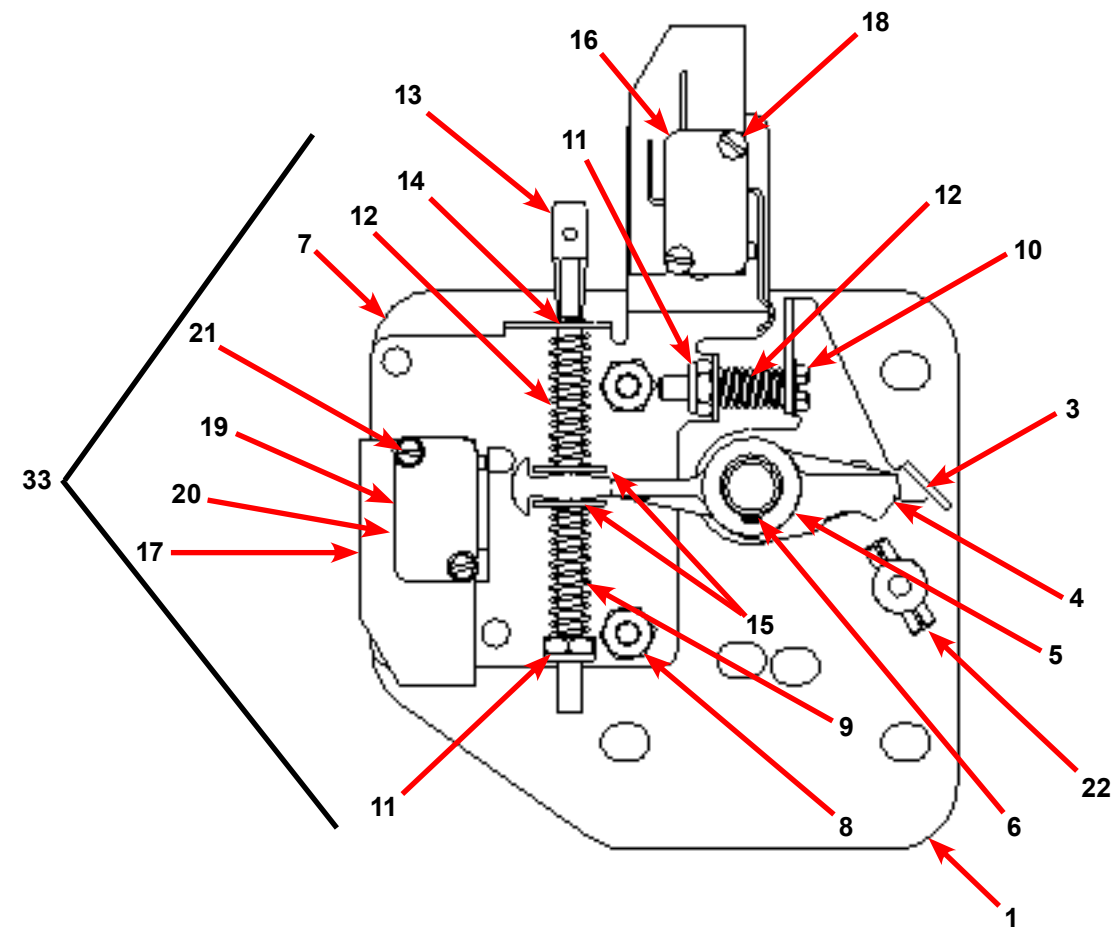

Key	Description	All Models	QTY
33	Lock Assy, Complete (#1-22) (includes #1 thru #22)	9885-031-001	1
1	Plate Assy, Door Lock	9982-346-001	1
2	Washer, Flat (SS or Brass)	8641-581-030	1
3	Actuator, Latching Switch	9008-005-001	1
4	Pawl, Locking	9732-346-002	1
5	Washer, Spring	8641-569-003	1
6	Ring, Retaining	9487-200-004	1
7	Bracket Switch	9029-163-001	1
8	Nut, Hex 10-32 UNF	8640-413-002	2
9	Spring, Actuating	9534-364-002	1
10	Screw, Hx. 10-32 x 1"	9545-012-020	1
11	Nut, Elastic Stop 10-32	8640-413-004	2
12	Spring, Return	9534-364-001	2
13	Pin, Guide	9451-193-001	1

Key	Description	All Models	QTY
14	Ring, Retaining	9487-200-005	1
15	Washer	8641-581-031	1
16	Switch, Latching Sensing	9539-461-008	1
17	Shield, Switch	9550-169-003	3
18	Screw 4-40 x 5/8"	9545-020-001	2
18	Nut, Twin 4-40	8640-401-001	1
19	Switch, Locking Sensing	9539-461-007	2
20	Actuator, Switch Locking	9008-006-003	1
21	Screw 4-40 x 1 1/8"	9545-020-003	2
21	Nut, Twin 4-40	640-401-001	1
*	Spacer Sensor	9538-182-001	*
22	Pin, Dowel (for door cam)	9451-181-004	1
*	Shim, Door Lock, Thin	9552-037-001	AR
*	Screw, Lock mtg 1/4"-20 x 3/4"	9545-018-014	3
*	Lockwasher 1/4" Ext tooth	8641-582-007	3

Gear Motor Door Lock Assembly

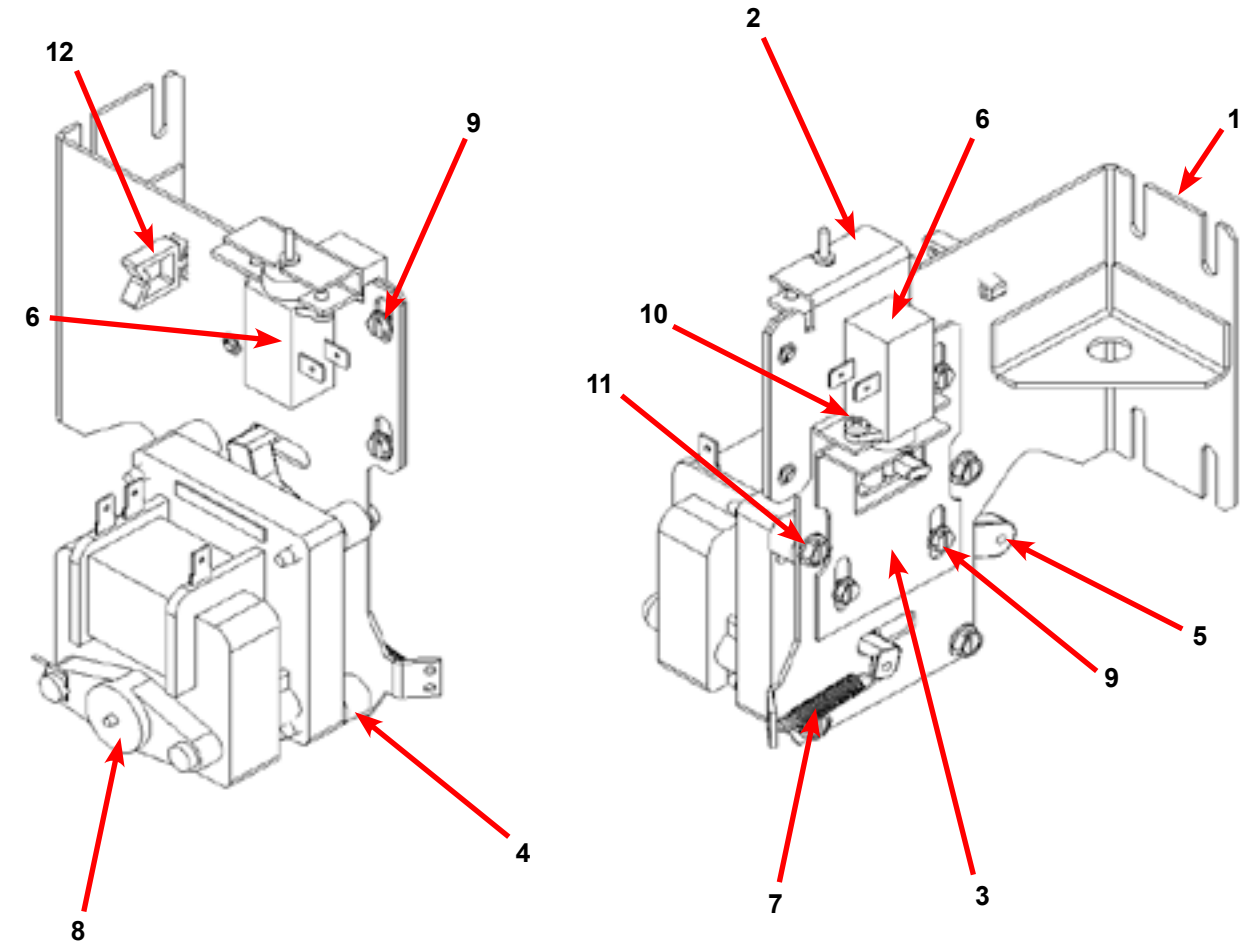

Key	Description	T300	T350	T400	T450	T600	QTY
*	Actuator Assembly (Includes 1-10, Rod NOT included)	9892-015-001	9892-015-001	9892-015-001	9892-015-001	9892-015-001	1
1	Bracket Assy, Slide Lock Actuator	9985-190-001	9985-190-001	9985-190-001	9985-190-001	9985-190-001	1
2	Bracket Assy, Slide - Unlock	9985-189-001	9985-189-001	9985-189-001	9985-189-001	9985-189-001	1
3	Bracket Slide Lock	9029-204-001	9029-204-001	9029-204-001	9029-204-001	9029-204-001	1
4	Spacer, Plastic	9538-157-021	9538-157-021	9538-157-021	9538-157-021	9538-157-021	4
5	Arm - Door Lock	9001-063-001	9001-063-001	9001-063-001	9001-063-001	9001-063-001	1
6	Thermoactuator - Door Lock Relay 120v	9586-001-001	9586-001-001	9586-001-001	9586-001-001	9586-001-001	2
7	Spring - Extension	9534-350-001	9534-350-001	9534-350-001	9534-350-001	9534-350-001	1
8	Motor & Gear Assembly 120v	9914-137-015	9914-137-015	9914-137-015	9914-137-015	9914-137-015	1
9	Screw -Hxwshrhdslems, 6-32 x 3/16	9545-044-003	9545-044-003	9545-044-003	9545-044-003	9545-044-003	6
10	Cross Recessed PAn Hd Tapping screw	9545-031-011	9545-031-011	9545-031-011	9545-031-011	9545-031-011	4
11	Screw - hxwshdsl, 10-24 - 1.25f, ctd	9545-046-007	9545-046-007	9545-046-007	9545-046-007	9545-046-007	4
12	Standoff-Wire	9527-007-001	9527-007-001	9527-007-001	9527-007-001	9527-007-001	1
*	Rod, Door Lock	9497-225-011	9497-225-011	9497-225-012	9497-225-012	9497-225-010	1

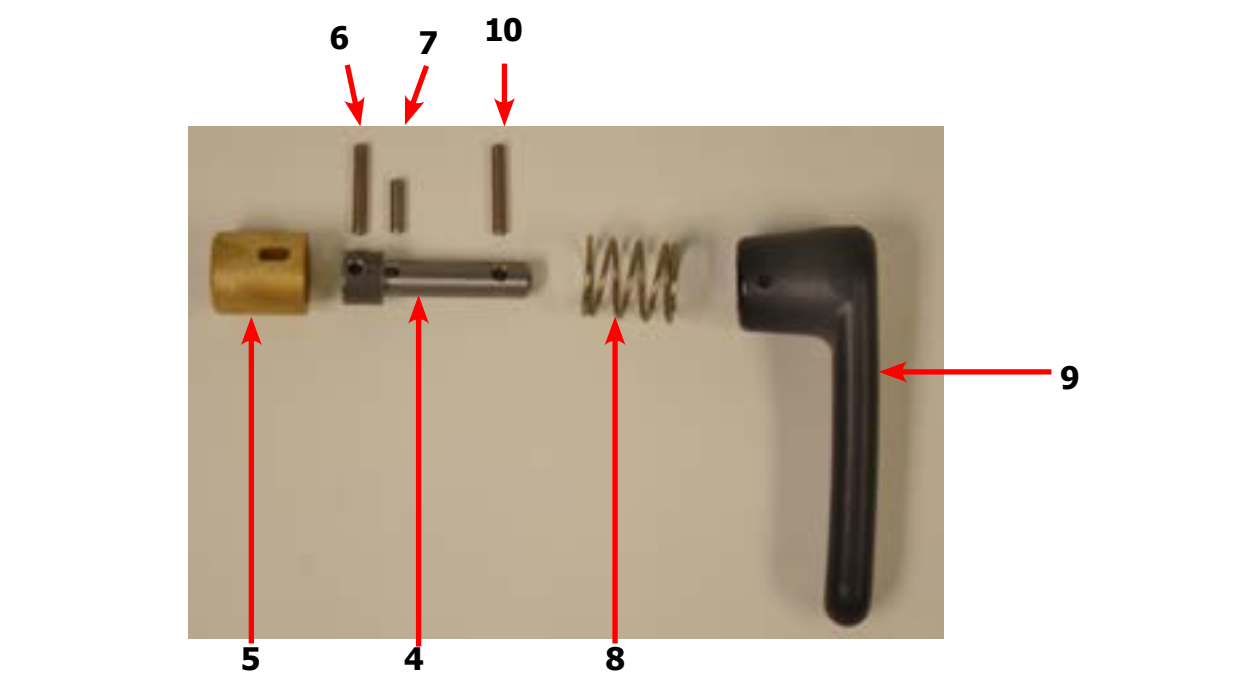
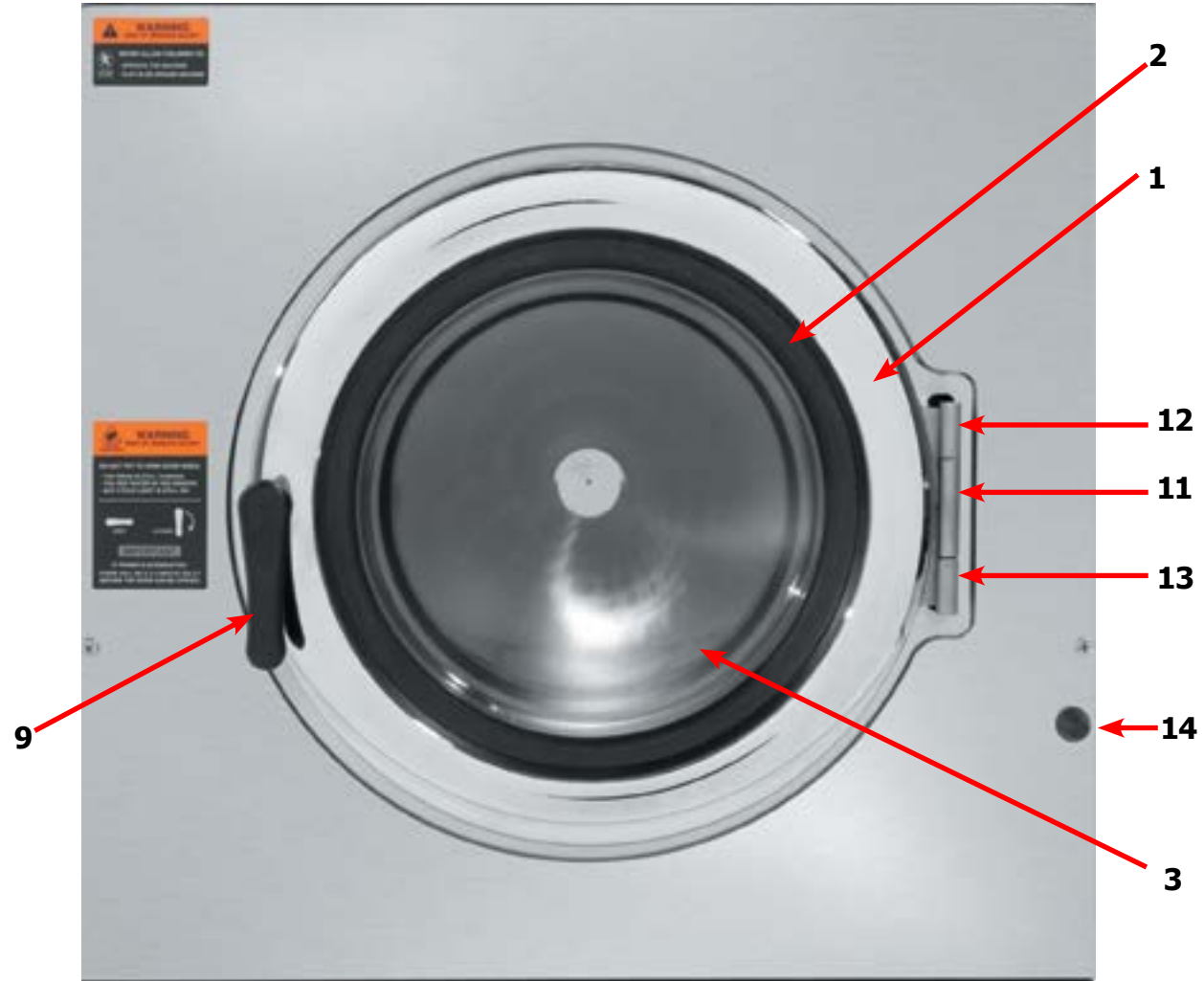

Loading Door Part # by Model

Key	Description	T300	T350	T400	T450	T600	QTY
*	Loading Door, Complete #1-10	9960-308-001	9960-308-001	9960-309-001	9960-309-001	9960-309-001	1
1	Loading Door, Ring	9487-264-002	9487-264-002	9487-265-002	9487-265-002	9487-265-002	1
2	Gasket, Loading Door	9206-411-002	9206-411-002	9206-419-001	9206-419-001	9206-419-001	1
3	Window, Loading Door	9635-018-001	9635-018-001	9635-016-001	9635-016-001	9635-016-001	1
*	Shaft Assy, Locking (includes 4 thru 7)	9913-136-001	9913-136-001	9913-136-001	9913-136-001	9913-136-001	1
4	Shaft, Door Locking	9537-195-002	9537-195-002	9537-195-002	9537-195-002	9537-195-002	1
5	Cam, Locking	9095-051-001	9095-051-001	9095-051-001	9095-051-001	9095-051-001	1
6	Pin, Groove (1 1/4)	9451-181-005	9451-181-005	9451-181-005	9451-181-005	9451-181-005	1
7	Pin, Groove (3/4)	9451-181-004	9451-181-004	9451-181-004	9451-181-004	9451-181-004	1
8	Spring, Lock Cam	9534-360-002	9534-360-002	9534-360-002	9534-360-002	9534-360-002	1
9	Handle, Door	9244-091-001	9244-091-001	9244-091-001	9244-091-001	9244-091-001	1
10	Pin, Door Handle (groove)	9451-181-005	9451-181-005	9451-181-005	9451-181-005	9451-181-005	1
11	Door Hinge Assembly Mounts to Tub Front	9955-030-001	9955-030-001	9955-030-001	9955-030-001	9955-030-001	
*	Shim, Loading Door Hinge (Thin)	9552-036-001	9552-036-001	9552-036-001	9552-036-001	9552-036-001	2
*	Screw, 5/16-18x3/4	9545-014-009	9545-014-009	9545-014-009	9545-014-009	9545-014-009	3
*	Lock Washer, 5/16	8641-582-009	8641-582-009	8641-582-009	8641-582-009	8641-582-009	3
12	Leaf Assembly-Hinge, Top	9845-008-001	9845-008-001	9845-008-001	9845-008-001	9845-008-001	1
13	Leaf Assembly-Hinge, Bottom	9845-005-002	9845-005-002	9845-005-002	9845-005-002	9845-005-002	1
*	Screw, 5/16x5/8	9545-056-002	9545-056-002	9545-056-002	9545-056-002	9545-056-002	3
14	Bumper-Loading Door	9051-055-001	9051-055-001	9051-055-001	9051-055-001	9051-055-001	1
*	Nut, 1/4, 20UNC, 2B	8640-414-006	8640-414-006	8640-414-006	8640-414-006	8640-414-006	1

Loading Door Hinge 180 Degree Opening

Key	Description	T300	T350	T400	T450	T600	QTY
1	Door Hinge Assembly (mounts to tub front)	9955-030-001	9955-030-001	9955-030-001	9955-030-001	9955-030-001	1
*	Shim, Loading Door Hinge (Thin)	9552-036-001	9552-036-001	9552-036-001	9552-036-001	9552-036-001	2
*	Screw, 5/16-18x3/4	9545-014-009	9545-014-009	9545-014-009	9545-014-009	9545-014-009	3
*	Lock Washer, 5/16	8641-582-009	8641-582-009	8641-582-009	8641-582-009	8641-582-009	3
2	Leaf Assembly-Hinge, Top	9845-008-001	9845-008-001	9845-008-001	9845-008-001	9845-008-001	1
3	Leaf Assembly-Hinge, Bottom	9845-005-002	9845-005-002	9845-005-002	9845-005-002	9845-005-002	1
4	Screw, 5/16x5/8	9545-056-002	9545-056-002	9545-056-002	9545-056-002	9545-056-002	3
*	Red Wire (Door Close Switch)	8220-063-025	8220-063-025	8220-063-025	8220-063-025	8220-063-025	1
*	Black Wire (Door Close Switch)	8220-063-026	8220-063-026	8220-063-026	8220-063-026	8220-063-026	1
5	Switch, Door Hinge Close (Plunger)	9539-492-001	9539-492-001	9539-492-001	9539-492-001	9539-492-001	1
6	Door Ring	9487-264-002	9487-264-002	9487-265-002	9487-265-002	9487-265-002	1
7	Gasket, Door Glass	9206-411-002	9206-411-002	9206-419-001	9206-419-001	9206-419-001	1
8	Window, Cloths	9635-018-001	9635-018-001	9635-016-001	9635-016-001	9635-016-001	1
9	Trim Edge Protector	9578-092-004	9578-092-004	9578-092-005	9578-092-005	9578-092-005	1
*	Bumper-Loading Door	9051-055-001	9051-055-001	9051-055-001	9051-055-001	9051-055-001	1
*	Nut, 1/4, 20UNC, 2B	8640-414-006	8640-414-006	8640-414-006	8640-414-006	8640-414-006	1

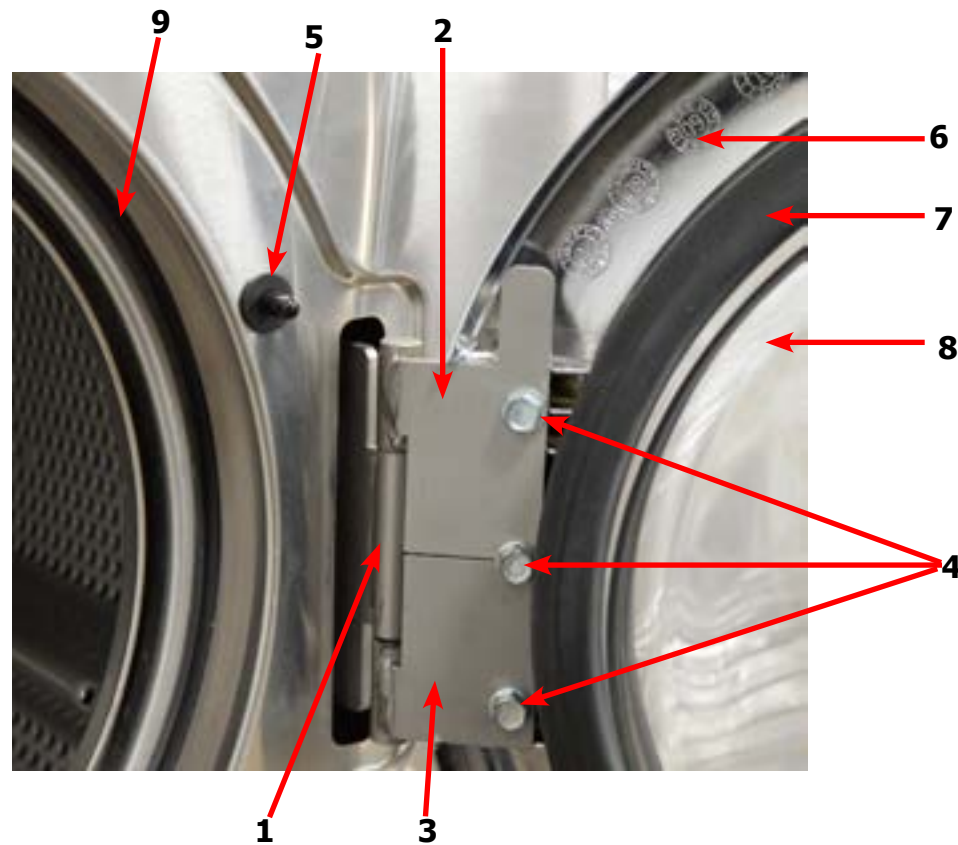

Water Inlet Valve Breakdown Part # by Model

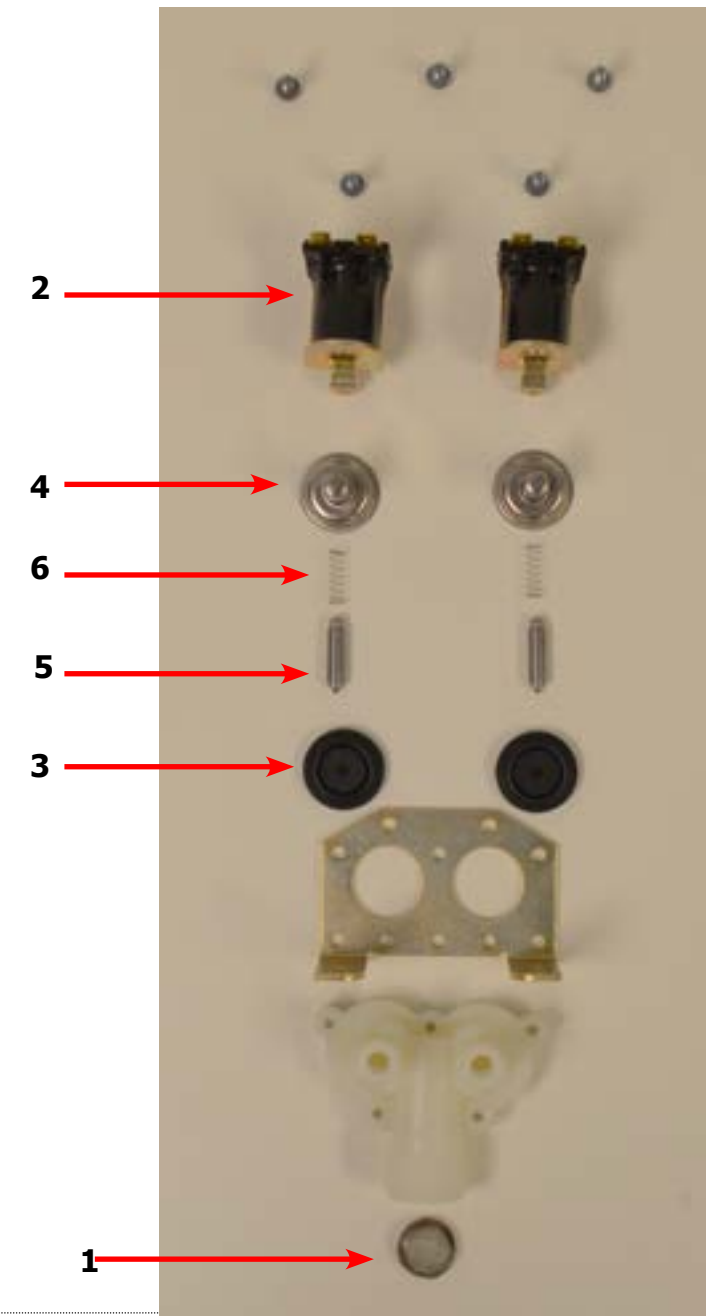

Key	Description	T300	T350	T400	T450	T600	QTY
*	Valve, Water Inlet (includes 1 thru 6)	9379-183-012	9379-183-012	9379-183-012	9379-183-012	9379-183-012	2
1	Screen, Inlet end of valve	9555-056-001	9555-056-001	9555-056-001	9555-056-001	9555-056-001	2
2	Coil Assy., 120 V Invensys	9089-017-001	9089-017-001	9089-017-001	9089-017-001	9089-017-001	2
*	Diaphragm Invensys (EPDM)	9118-049-001	9118-049-001	9118-049-001	9118-049-001	9118-049-001	2
*	Diaphragm Invensys (Viton)	9118-049-002	9118-049-002	9118-049-002	9118-049-002	9118-049-002	2
3	Diaphragm Invensys (EPDM NSF)	9118-049-003	9118-049-003	9118-049-003	9118-049-003	9118-049-003	2
4	Guide, Solenoid Invensys	9211-021-002	9211-021-002	9211-021-002	9211-021-002	9211-021-002	2
5	Armature Invensys	9015-008-001	9015-008-001	9015-008-001	9015-008-001	9015-008-001	2
6	Spring, Armature Invensys	9534-298-001	9534-298-001	9534-298-001	9534-298-001	9534-298-001	2

Water Inlet Part # by Model

Key	Description	T-300	T-350	T-400	T-450	T-600	QTY
1	Valve, Water Inlet (dual outlet) (see Water Inlet Valve Break-down for individual parts)	9379-183-012	9379-183-012	9379-183-012	9379-183-012	9379-183-012	2
*	Screw, Valve Mtg	9545-008-026	9545-008-026	9545-008-026	9545-008-026	9545-008-026	4
2	Vacuum Breaker	9610-001-001	9610-001-001	9610-001-001	9610-001-001	9610-001-001	1
*	Bracket, Vacuum Breaker	9029-266-001	9029-266-001	9029-078-001	9029-077-001	9029-077-001	1
*	Screw	9545-008-026	9545-008-026	9545-008-026	9545-008-026	9545-008-026	4
*	Hose, Vacuum Breaker to Tub	9242-458-001	9242-458-001				1
*	Clamp, Tub End	8654-117-009	8654-117-009				2
3	Hose, Vacume Breaker to Injec-tor			9242-461-001	9242-461-001	9242-461-001	1
4	Clamps			8654-117-014	8654-117-014	8654-117-014	1
5	Injector Assembly, Soap			9883-006-001	9883-010-001	9883-009-001	1
*	Hose, Injector to Tub Back			9242-462-001	9242-462-001	9242-462-001	1
*	Clamps			8654-117-014	8654-117-014	8654-117-014	1
*	Cap-Injector Assy			0935-127-001	0935-127-001	0935-127-001	1
*	Clamp			9242-117-014	9242-117-014	9242-117-014	1
6	Plate-Water Valves	9452-813-001	9452-813-001	9452-813-001	9452-813-001	9452-813-001	1
7	Nut-Elastic stop, #10-32	8640-413-004	8640-413-004	8640-413-004	8640-413-004	8640-413-004	2
8	Shield over Water Valves Plastic	9550-186-001	9550-186-001	9550-186-001	9550-186-001	9550-186-001	1
9	Clip Push on	9083-121-001	9083-121-001	9083-121-001	9083-121-001	9083-121-001	2
*	Hose, Bulk 1/2" I.D.	9242-453-001	9242-453-001	9242-453-001	9242-453-001	9242-453-001	AR
10	Clamp, Hose-Worm	8654-117-015	8654-117-015	8654-117-015	8654-117-015	8654-117-015	12
*	Flow restrictor	9475-002-002	9475-002-002	9475-002-002	9475-002-002	9475-002-002	2
*	Dispenser, Soap	9122-005-004	9122-005-004	9122-005-004	9122-005-004	9122-005-004	1
*	Gasket, Dispenser	9206-416-001	9206-416-001	9206-416-001	9206-416-001	9206-416-001	1
*	Nut, Spring-SS	8640-399-007	8640-399-007	8640-399-007	8640-399-007	8640-399-007	4
*	Screw, Disp. Mtg	9545-008-012	9545-008-012	9545-008-012	9545-008-012	9545-008-012	4
11	Hose Tub to Drain Valve	9242-468-001	9242-468-001	9242-456-001	9242-456-001	9242-456-001	1
12	Clamp	8654-117-014	8654-117-014	8654-117-014	8654-117-014	8654-117-014	1
13	Hose, Pressure Switch	9242-175-000	9242-175-000	9242-175-007	9242-175-007	9242-175-001	1
14	Clamp, Pressure Switch Hose	8654-117-015	8654-117-015	8654-117-015	8654-117-015	8654-117-015	1

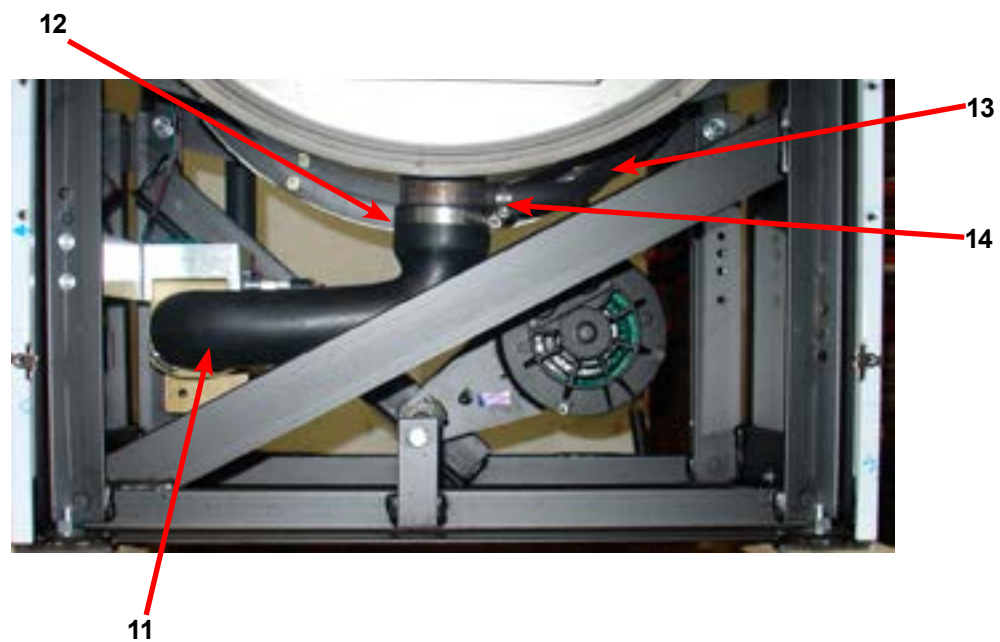
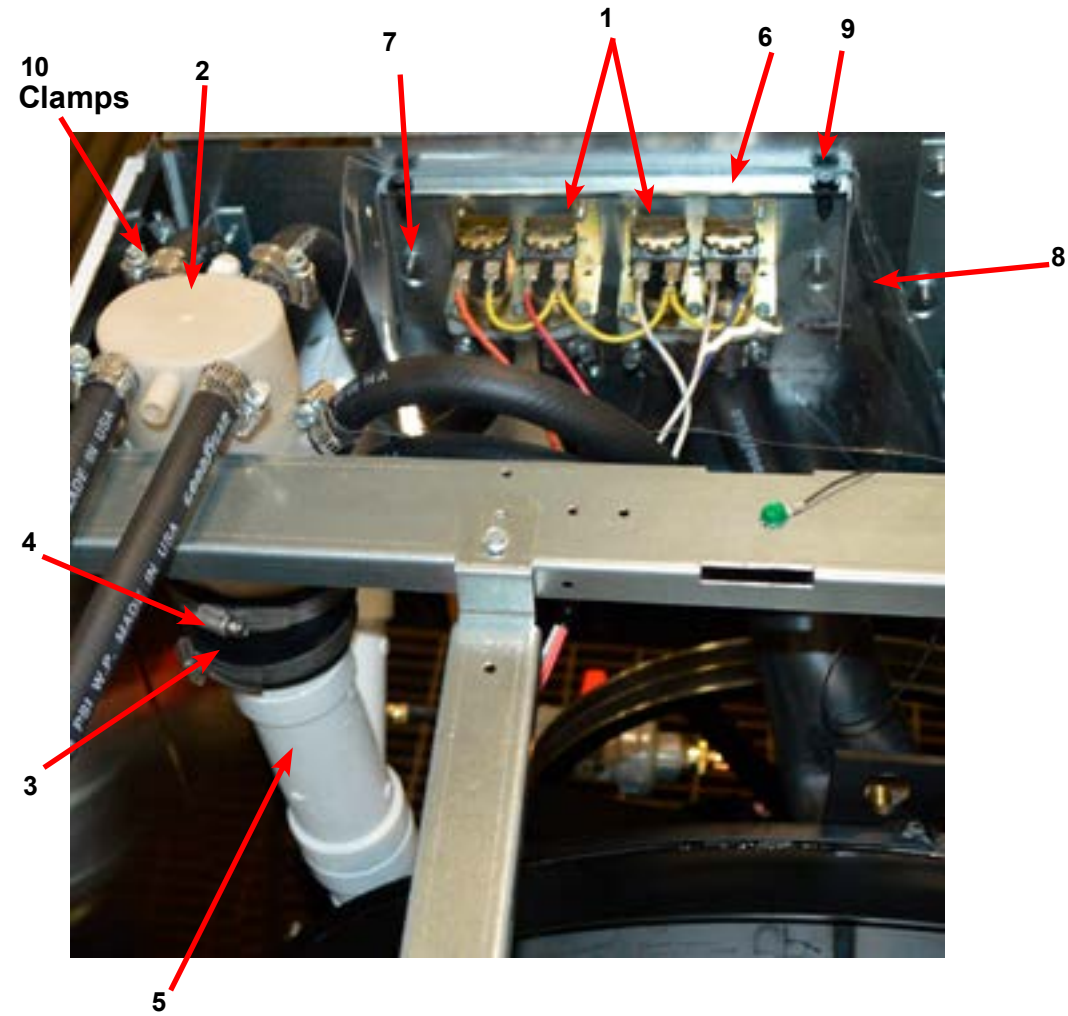

Chassis and Drain Part # by Model

Key	Description	T-300	T-350	T-400	T-450	T-600	QTY
1	Base Assy,Frame	9945-093-002	9945-119-002	9945-140-002	9945-141-002	9945-097-002	1
2	Outer Tub Assy	9930-135-001	9930-143-001	9930-152-001	9930-142-001	9930-146-001	1
*	Tub & Cylinder Assy	9869-159-001	9869-160-002	9869-161-001	9869-162-001	9869-163-001	1
3	Ring Assy, Tub Mtg-Front	9950-045-002	9950-045-001	9950-051-002	9950-051-004	9950-051-004	1
4	Ring Assy.Clamp Tub Mtg.- Rear	9950-046-002	9950-046-002	9950-056-002	9950-056-002	9950-056-003	1
5	Bolt, 1/2" x 1 1/4 Rings to Base	9545-017-009					4
6	Nut, Wizlock, 1/2-13	8640-417-005	8640-417-005	8640-417-005	8640-417-005	8640-417-005	1
7	Hose, Tub to Drain Valve	9242-468-001	9242-468-001	9242-456-001	9242-456-001	9242-456-001	1
8	Clamp, Hose (Tub to Drain Valve)	8654-117-014	8654-117-014	8654-117-014	8654-117-014	8654-117-014	2
9	Valve, Drain	9379-199-001	9379-199-001	9379-200-001	9379-200-001	9379-200-001	1
10	Hose, Drain Valve to Tube	9242-451-002	9242-451-002	9242-457-001	9242-457-001	9242-457-001	1
11	Clamp, Hose (Drain Valve to Tube)	8654-117-014	8654-117-014	8654-117-014	8654-117-014	8654-117-014	2
12	Bracket, Drain Valve	9029-005-001	9029-005-001	9029-056-001	9029-052-001	9029-052-001	1
*	Screw, Valve to Bracket 12ABx1/2	9545-008-026	9545-008-026	9545-048-001	9545-008-026	9545-008-026	2
13	Tube Assy, Drain	9915-116-004	9915-125-002	9915-119-002	9915-119-002	9915-118-002	1
*	Screw Tube (Bracket to Base 1/4Bx3/4	9545-030-002	9545-030-002	9545-030-002	9545-030-002	9545-030-002	2
14	Hose, Overflow to drain	9242-449-002	9242-449-002	9242-449-002	9242-449-002	9242-449-002	1
*	Clamp, Overflow	8654-117-018	8654-117-018	8654-117-018	8654-117-018	8654-117-018	2
*	Lockwasher				8641-582-018	8641-582-018	4
*	Nut, Hex 5/8-11				8640-425-001	8640-425-001	4
*	Shim, Support Assembly (thin)	9552-038-003	9552-038-003	9552-038-003	9552-038-001	9552-038-001	AR
15	Injection Tube			9883-006-001	9883-010-001	9883-007-001	1
*	Hose-Inlet, Water (T300 & T350, Between Vacume Breaker and tub)	9242-458-001	9242-458-001				1
16	Dispenser Soap	9122-005-004	9122-005-004	9122-005-004	9122-005-004	9122-005-004	1
17	Gasket, Dispenser	9206-416-001	9206-416-001	9206-416-001	9206-416-001	9206-416-001	1
*	Nut Spring SS	8640-399-007	8640-399-007	8640-399-007	8640-399-007	8640-399-007	4
*	Screw, Disp. Mtg	9545-008-012	9545-008-012	9545-008-012	9545-008-012	9545-008-012	4
*	Hose, Dispenser to Tub	9242-450-002	9242-450-002	9242-450-002	9242-450-002	9242-450-001	1
*	Clamp, Dispenser Hose	8654-117-008	8654-117-008	8654-117-008	8654-117-008	8654-117-008	2
18	Back Ass'y, Tub	9732-137-001	9732-137-002	9732-137-002	9732-137-003	9732-137-003	1
19	Bolt, 7/16" x 2" Tub Back to Tub	9545-029-003	9545-029-003	9545-029-003	9545-029-003	9545-029-003	12
20	Nut, Flange Lock	8640-415-004	8640-415-004	8640-416-005	8640-416-005	8640-416-005	12

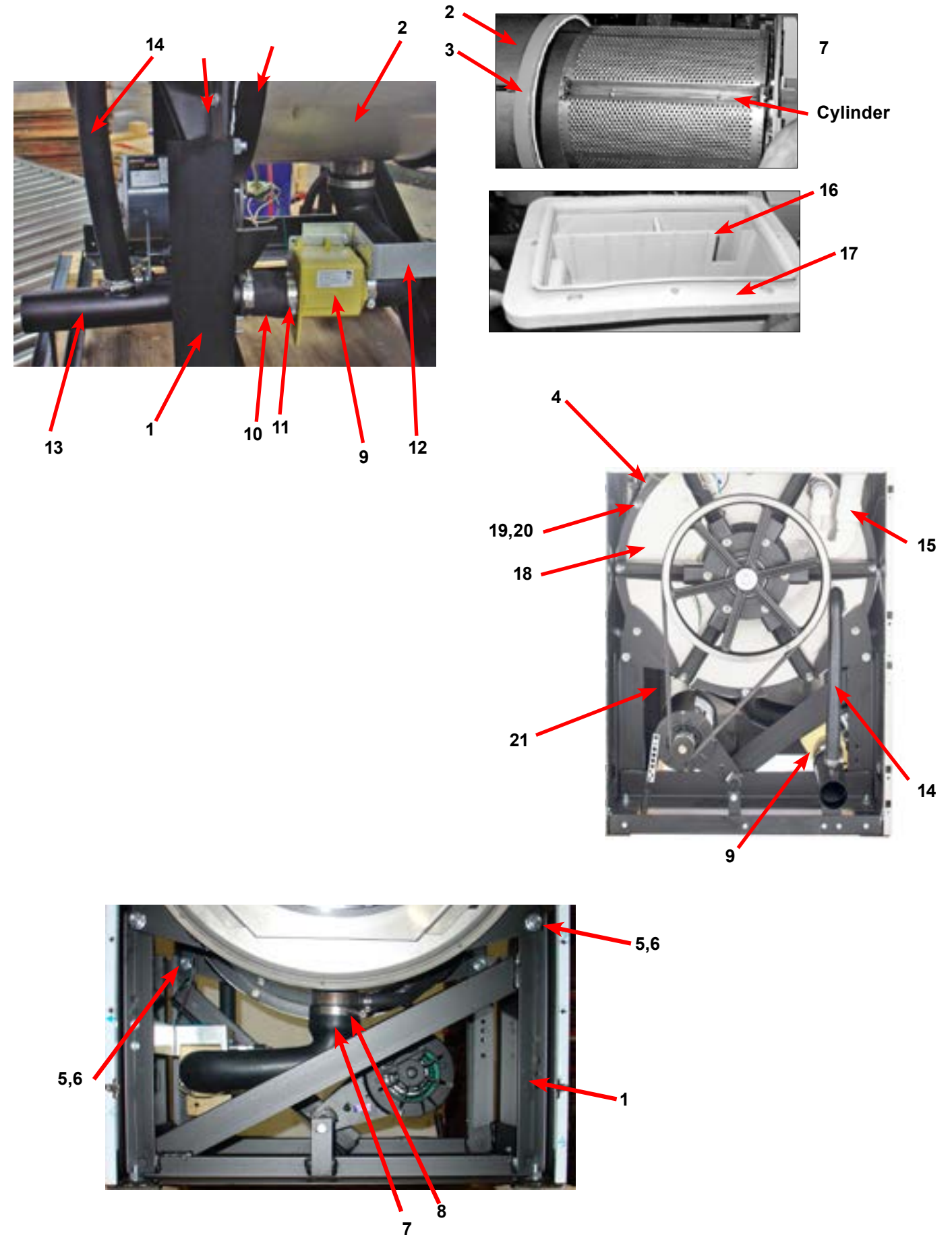

Electrical Components - Top Compartment 208/240VAC

Key	Description	T300	T350	T-400	T-450	T-600	QTY
*	Trough Assy,Controls 208-240 volt (all parts below #2-#43 & trough)	9857-210-002	9857-211-001	9857-212-001	9857-213-001	9857-214-001	1
1	Trough only	9839-018-001	9839-018-001	9839-018-001	9839-018-001	9839-018-001	1
*	Screw, Trough Sides	9545-008-026	9545-008-026	9545-008-026	9545-008-026	9545-008-026	4
*	Lockwasher #10	8641-582-006	8641-582-006	8641-582-006	8641-582-006	8641-582-006	4
*	Angle Support Trough	9003-337-001	9003-337-001	9003-337-001	9003-337-001	9003-271-001	1
*	Screw, Trough Bracket	9545-008-026	9545-008-026	9545-008-026	9545-008-026	9545-008-026	3
*	Harness-Power Terminal & Drive	9627-831-001	9627-831-001	9627-747-003	9627-747-003	9627-747-003	
2	Transformer, Control (Secondary Voltage to 115 volts)	8711-004-001	8711-004-001	8711-004-001	8711-004-001	8711-004-001	1
3	Screw, Mtg #10Bx1/2"	9545-008-026	9545-008-026	9545-008-026	9545-008-026	9545-008-026	4
*	Lockwasher #10	8641-582-006	8641-582-006	8641-582-006	8641-582-006	8641-582-006	4
4	Screw GRN. #10-32x 1/2"	9545-008-027	9545-008-027	9545-008-027	9545-008-027	9545-008-027	1
*	Lockwasher #10	8641-582-006	8641-582-006	8641-582-006	8641-582-006	8641-582-006	1
*	Lug, Grounding	8652-130-037	8652-130-037	8652-130-037	8652-130-037	8652-130-037	1
5	PCB assembly Relay Main	9473-006-001	9473-006-001	9473-006-001	9473-006-001	9473-006-001	1
*	Support-PCB, 3/8, Edge Holding	9548-285-001	9548-285-001	9548-285-001	9548-285-001	9548-285-001	6
6	Harness P17/Drain/Therm/Sol	9627-796-001	9627-796-001	9627-796-001	9627-796-001	9627-796-002	1
7	Harness P19/Water Valve	9627-795-003	9627-795-003	9627-795-003	9627-795-003	9627-795-004	1
*	Harness P8/P16	9627-794-001	9627-794-001	9627-794-001	9627-794-001	9627-794-001	1
8	Harness P20/P21	9627-793-001	9627-793-001	9627-793-001	9627-793-001	9627-793-001	1
9	PCB-Optional Relay	9473-007-001	9473-007-001	9473-007-001	9473-007-001	9473-007-001	1
10	Support-PCB, 3/8, Edge Holding	9548-285-001	9548-285-001	9548-285-001	9548-285-001	9548-285-001	4
11	Harness, P23 to P15	9627-798-001	9627-798-001	9627-798-001	9627-798-001	9627-798-001	1
12	Harness, P10	9627-799-001	9627-799-001	9627-799-001	9627-799-001	9627-799-001	1
13	Bushing , Wire 7/8	9053-067-002	9053-067-002	9053-067-002	9053-067-002	9053-067-002	2
14	Terminal Block Assy, POWER	9897-026-004	9897-026-004	9897-026-004	9897-026-004	9897-026-004	1
*	Screw, Mtg 8ABx1/2"	9545-045-012	9545-045-012	9545-045-012	9545-045-012	9545-045-012	2
15	Switch, Pressure	9539-491-001	9539-491-001	9539-489-002	9539-490-001	9539-489-002	1
16	Harness P5/Pressure	9627-804-001	9627-805-001	9627-805-001	9627-805-001	9627-806-001	1
17	Transformer, (Step Down) 120/2.3 VAC&24 VAC 50/60hz	8711-009-001	8711-009-001	8711-009-001	8711-009-001	8711-009-001	1
18	Screw, Transformer Mtg #8Bx1/4"	9545-045-001	9545-045-001	9545-045-001	9545-045-001	9545-045-001	2
*	Lockwasher #6 exttooth	8641-582-005	8641-582-005	8641-582-005	8641-582-005	8641-582-005	2
19	Fuse Holder Assy	9200-001-002	9200-001-002	9200-001-002	9200-001-002	9200-001-002	1
*	Fuse, 1.5Amp	8636-018-001	8636-018-001	8636-018-001	8636-018-001	8636-018-001	1
20	Label-Fuse, 1.5Amp	8502-716-001	8502-716-001	8502-716-001	8502-716-001	8502-716-001	1
*	Kit-Pressure Sensor, Electronic	9732-314-001	9732-314-001	9732-314-001	9732-314-001	9732-314-001	1
21	Kit-Repaacement, Pressure Sensor (only)	9732-315-001	9732-315-001	9732-315-001	9732-315-001	9732-315-001	1
*	Support-PCB, 3/8", Edge Holding	9458-285-001	9458-285-001	9458-285-001	9458-285-001	9458-285-001	1
22	Transformer-120/18VAC, 5 VA	8711-015-001	8711-015-001	8711-015-001	8711-015-001	8711-015-001	1
23	Screw, 8B x 1/4	9545-045-001	9545-045-001	9545-045-001	9545-045-001	9545-045-001	1
*	Wire Assy BLK/BLU	8220-001-233	8220-001-233	8220-001-233	8220-001-233	8220-001-233	1
*	Wire Assy RED/BLU	8220-001-232	8220-001-232	8220-001-232	8220-001-232	8220-001-232	1
*	Clamp, Cable 3/16"	8654-125-005	8654-125-005	8654-125-005	8654-125-005	8654-125-005	*

Electrical Components - Top Compartment

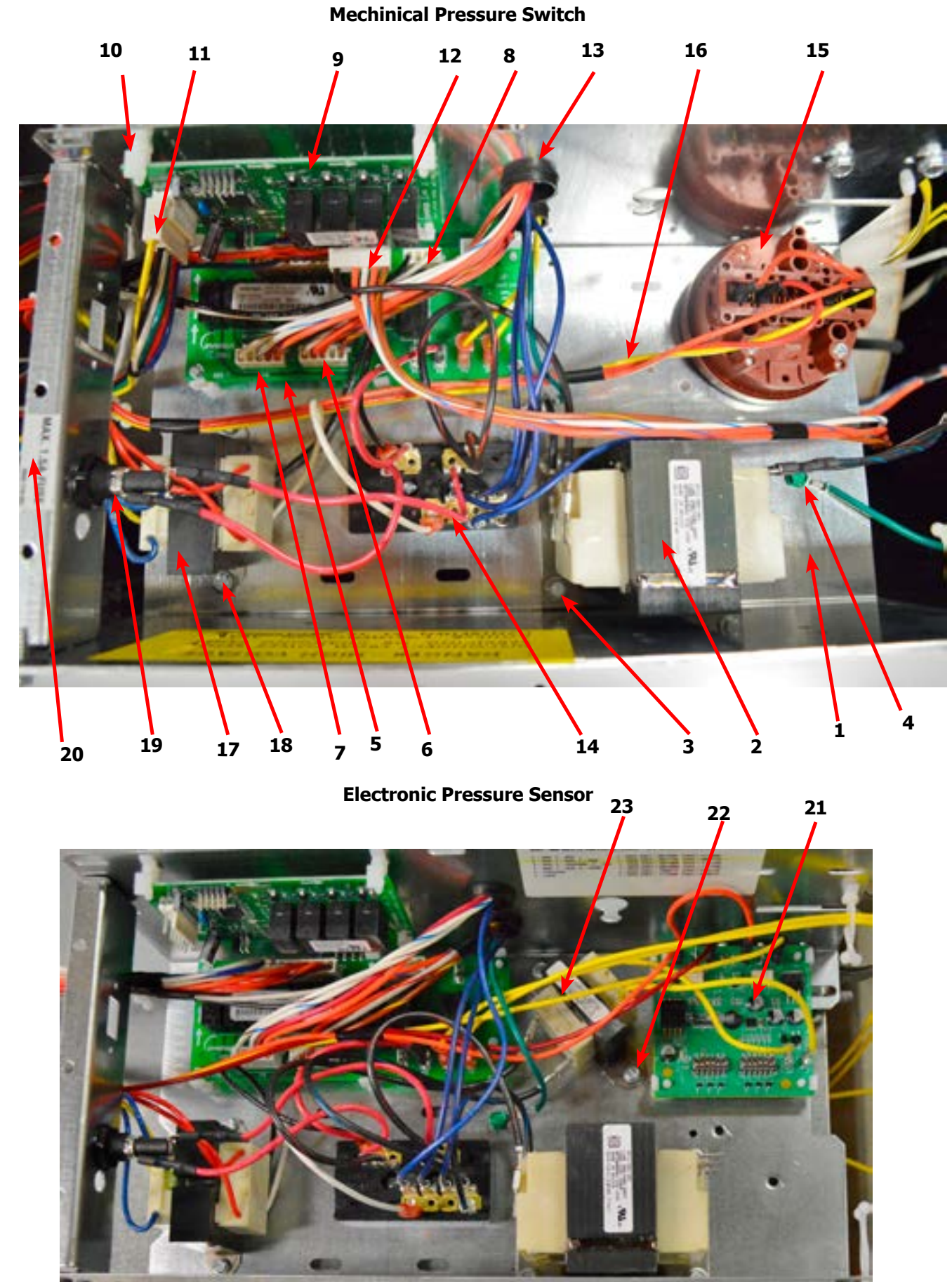

Electrical Components Cont.- Top Compartment 120VAC

Key	Description	T300 120V	QTY
*	Trough Assy,Controls 120 Volt (all parts below #2-#43 & trough)	9857-210-001	1
1	Trough only	9839-018-001	1
*	Screw, Trough Sides	9545-008-026	4
*	Lockwasher #10	8641-582-006	4
*	Angle Support Trough	9003-337-001	1
*	Screw, Trough Bracket	9545-008-026	3
	Cord Assembly-Service	9802-037-009	1
*	Wire Assembly, Red, 29"	8220-065-030	1
*	Wire Assembly, Blue, 29"	8220-065-031	1
3	Screw GRN. #10-32x 1/2"	9545-008-027	2
*	Lockwasher #10	8641-582-006	2
4	Lug, Grounding	8652-130-037	1
5	PCB assembly Relay Main	9473-006-001	1
*	Support-PCB, 3/8, Edge Holding	9548-285-001	6
6	Harness Drain/Therm/Sol	9627-796-001	1
7	Harness P19/Water Valve	9627-795-003	1
*	Harness P8/P16	9627-794-001	1
8	Harness P20/P21	9627-793-001	1
9	PCB-Optional Relay	9473-007-001	1
10	Support-PCB, 3/8, Edge Holding	9548-285-001	4
11	Harness, P23 to P15	9627-798-001	1
12	Harness, P10	9627-799-001	1
13	Bushing , Wire 7/8	9053-067-002	2
14	Terminal Block Assy, POWER	9897-026-004	1
*	Screw, Mtg 8Bx1/2"	9545-045-012	2
15	Switch, Pressure	9539-491-001	1
16	Harness P5/Pressure	9627-804-001	1
17	Transformer, (Step Down) 120/2.3 VAC&24 VAC 50/60hz	8711-009-001	1
18	Screw, Transformer Mtg #8Bx1/4"	9545-045-001	2
*	Lockwasher #6 exttooth	8641-582-005	2
19	Fuse Holder Assy	9200-001-002	1
*	Fuse, 1.5Amp	8636-018-001	1
20	Label-Fuse, 1.5Amp after Serial # W1.15244.001	8502-716-001	1
*	Kit-Pressure Sensor, Electronic	9732-314-001	1
*	Kit-Repaacement, Pressure Sensor (only)	9732-315-001	1
*	Support-PCB, 3/8", Edge Holding	9458-285-001	4
*	Transformer-120/18VAC, 5 VA	8711-015-001	1
*	Screw, 8B x 1/4"	9545-045-001	2
*	Wire Assy BLK/BLU	8220-001-233	1
*	Wire Assy RED/BLU	8220-001-232	1

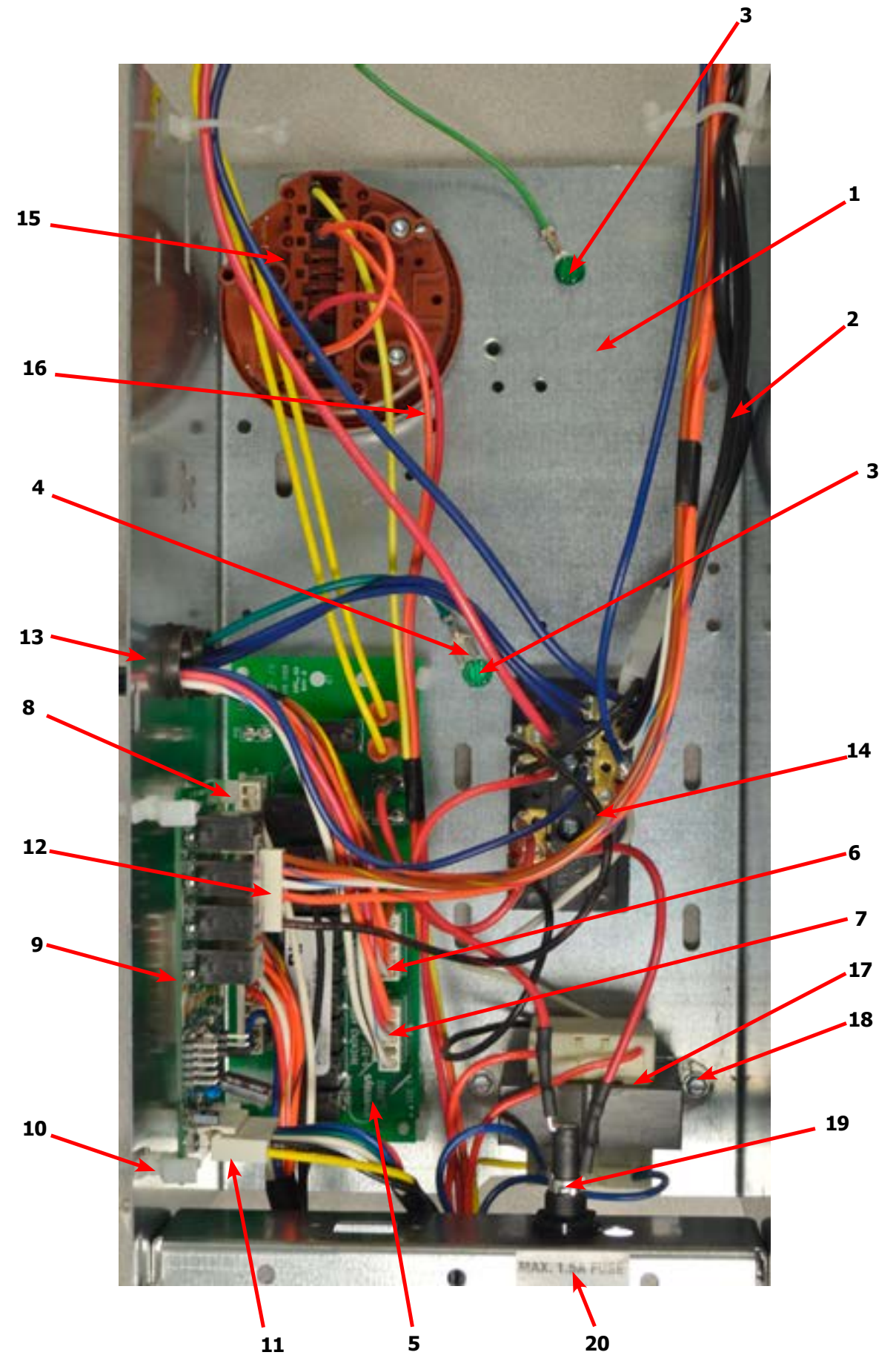

Control Panel Part # by Model

Key	Description	T-300	T-350	T-400	T-450	T-600	QTY
1	Panel Control Assembly(panel only)	9989-477-001	9989-477-001	9989-478-001	9989-478-001	9989-479-001	1
*	Screw, Hxwshrhdundct #10Bx 1/2" (Control to sides)	9545-008-026	9545-008-026	9545-008-026	9545-008-026	9545-008-026	4
2	Plate-Latch, Top	9452-625-001	9452-625-001	9452-625-001	9452-625-001	9452-625-001	1
3	Nut, #8-32	8640-412-005	8640-412-005	8640-412-005	8640-412-005	8640-412-005	2
4	Post Locator Top	9467-024-001	9467-024-001	9467-024-001	9467-024-001	9467-024-001	2
5	Nut Hexkeps #6-32	8640-411-003	8640-411-003	8640-411-003	8640-411-003	8640-411-003	2
6	Locator Panel	9355-001-001	9355-001-001	9355-001-001	9355-001-001	9355-001-001	2
7	Screw FillHDCR 10Bx1/2" Guide	9545-008-023	9545-008-023	9545-008-023	9545-008-023	9545-008-023	2
8	Shield, PCB	9550-184-001	9550-184-001	9550-184-001	9550-184-001	9550-184-001	1
9	Nut, #8-32	8640-412-005	8640-412-005	8640-412-005	8640-412-005	8640-412-005	3
10	Spacer Pushbutton (Micro)	9538-192-001	9538-192-001	9538-192-001	9538-192-001	9538-192-001	1
11	Pushbutton Control (Black)	9035-062-003	9035-062-003	9035-062-003	9035-062-003	9035-062-003	1
12	Retainer Pushbutton (Micro)	9486-158-001	9486-158-001	9486-158-001	9486-158-001	9486-158-001	1
13	Nut Hexelasticstop #4-40	8640-424-002	8640-424-002	8640-424-002	8640-424-002	8640-424-002	2
14	PCB assembly Control /Display	9473-004-010	9473-004-010	9473-004-010	9473-004-010	9473-004-010	1
*	Spacer Plastic #6x9/16	9538-157-018	9538-157-018	9538-157-018	9538-157-018	9538-157-018	5
15	Nut Elasticstop #6-32	8640-411-002	8640-411-002	8640-411-002	8640-411-002	8640-411-002	4
16	Nut, #8-32 (Grounding PCB)	8640-412-005	8640-412-005	8640-412-005	8640-412-005	8640-412-005	1
17	Harness LEDPCB	9627-797-001	9627-797-001	9627-797-001	9627-797-001	9627-797-001	1
*	Harness Doorlock, Switches	9627-791-003	9627-791-003	9627-791-003	9627-791-003	9627-791-004	1
*	Harness, P5/Pressure Switch	9627-804-001	9627-805-001	9627-805-001	9627-805-001	9627-806-001	1
18	PCB assembly Mode lights	9473-005-001	9473-005-001	9473-005-001	9473-005-001	9473-005-001	1
*	Spacer Plastic #6x9/16	9538-157-018	9538-157-018	9538-157-018	9538-157-018	9538-157-018	2
19	Nut Hexkeps #6-32	8640-411-003	8640-411-003	8640-411-003	8640-411-003	8640-411-003	2
20	Light, LED,ADD BLEACH Assembly	9794-001-001	9794-001-001	9794-001-001	9794-001-001	9794-001-001	1
*	Spacer Plastic #6x9/16	9538-157-018	9538-157-018	9538-157-018	9538-157-018	9538-157-018	2
21	Nut Hexkeps #6-32	8640-411-003	8640-411-003	8640-411-003	8640-411-003	8640-411-003	2
22	Nameplate,Control Panel (Black)	9412-217-001	9412-218-001	9412-219-001	9412-220-001	9412-221-001	1
23	Lock Assy, Run/Program-W/Harness & Key	8650-027-001	8650-027-001	8650-027-001	8650-027-001	8650-027-001	1
24	Key-Run/Program (N561)	6292-006-013	6292-006-013	6292-006-013	6292-006-013	6292-006-013	1
25	Motor Ass'y, Door Locking (see Door Lock Group for parts breakdown)	9892-015-001	9892-015-001	9892-015-001	9892-015-001	9892-015-001	1
26	Hex Nuts (mounting Door Lock-assy. to control panel)	8640-412-005	8640-412-005	8640-412-005	8640-412-005	8640-412-005	3
*	Battery-Control Memory (CR1220)	8612-001-001	8612-001-001	8612-001-001	8612-001-001	8612-001-001	1

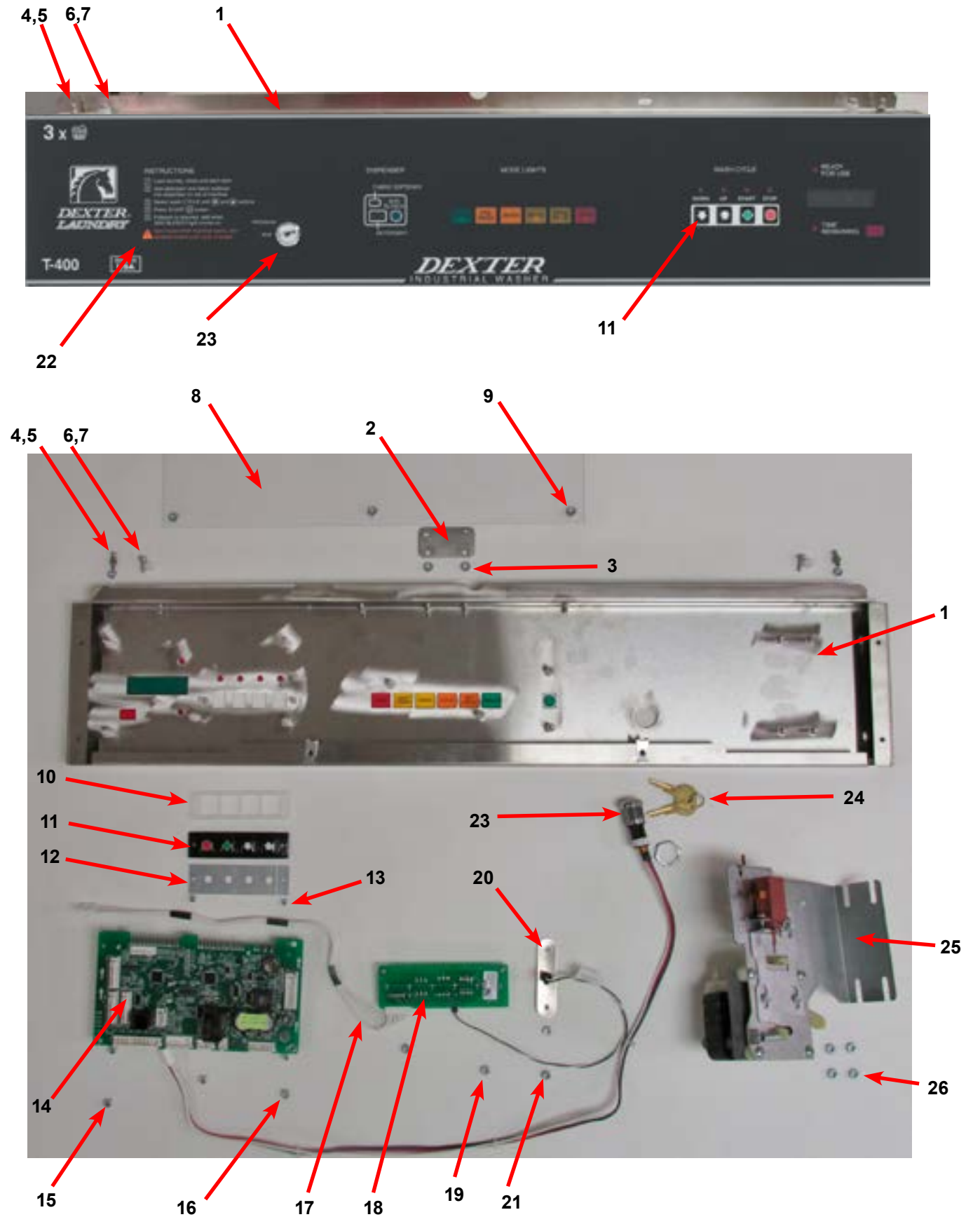

Transformer, Electrical -39 models

Key	Component	T-300	T-350	T-400	T-450	T-600	QTY
*	Operators Manual	8514-236-002	8514-237-002	8514-238-002	8514-239-002	8514-240-002	
*	Wiring Schematic & Diagram	9506-551-001	9506-553-001	9506-553-001	9506-553-001	9506-555-001	1
*	Controls Assembly - Trough,	9857-210-003	9857-211-002	9857-212-002	9857-213-002	9857-214-002	1
*	Wiring Harness, Power Terminal Block	9627-747-006	9627-747-006	9627-747-006	9627-747-006	9627-747-006	1
1	Circuit Breaker	5198-211-002	5198-211-002	5198-211-002	5198-211-002	5198-211-002	1
*	Instructions, Transformer Connect	8507-230-003	8507-230-003	8507-230-003	8507-230-003	8507-230-003	1
2	Controls Transformer	8711-004-003	8711-004-003	8711-004-003	8711-004-003	8711-004-003	1
3	Transformer	8711-009-003	8711-009-003	8711-009-003	8711-009-003	8711-009-003	1
*	Terminal Strip Marker	9558-028-002	9558-028-002	9558-028-002	9558-028-002	9558-028-002	1

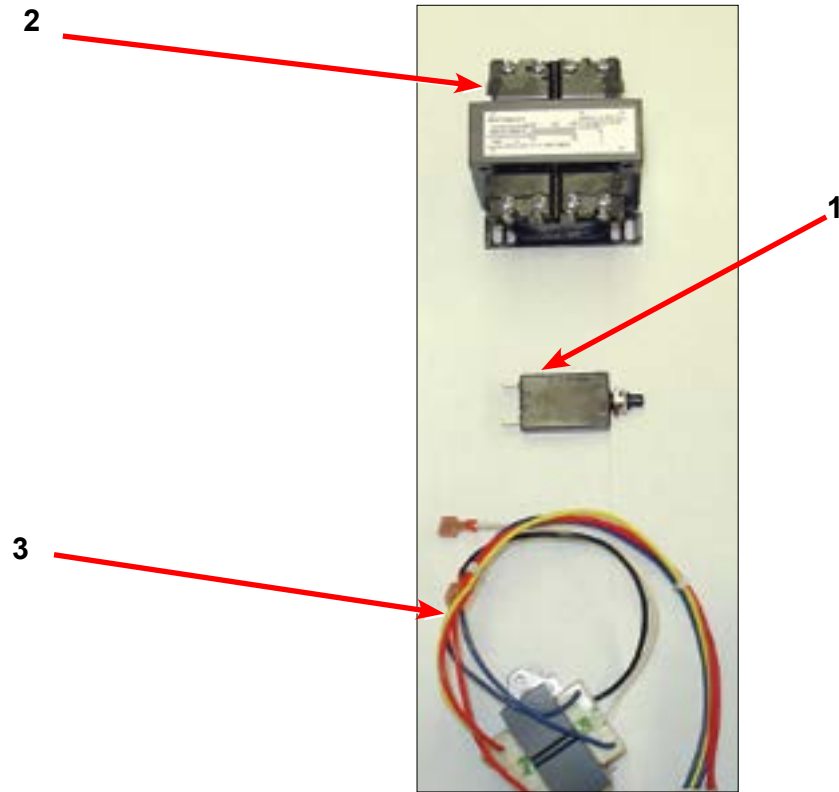

Water Valve, Drain Valve -39 models

Key	Component	T-300	T-350	T-400	T-450	T-600	QTY
1	Water Valve	9379-183-013	9379-183-013	9379-183-013	9379-183-013	9379-183-013	2
2	Drain Valve 2" inch	9379-199-002	9379-199-002				1
3	Drain Valve 3" inch			9379-202-002	9379-202-002	9379-202-002	1

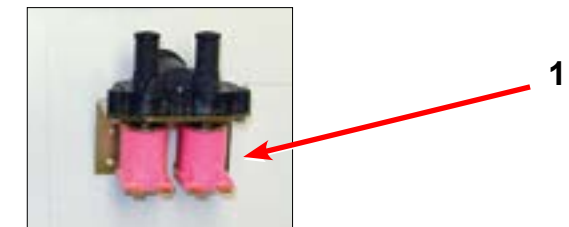
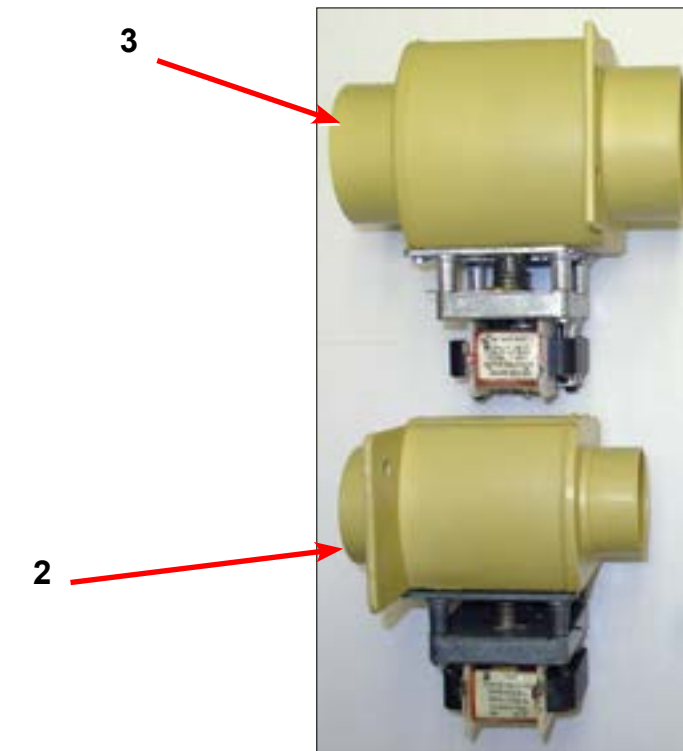

Gear Motor Door Lock Assembly 24V AC

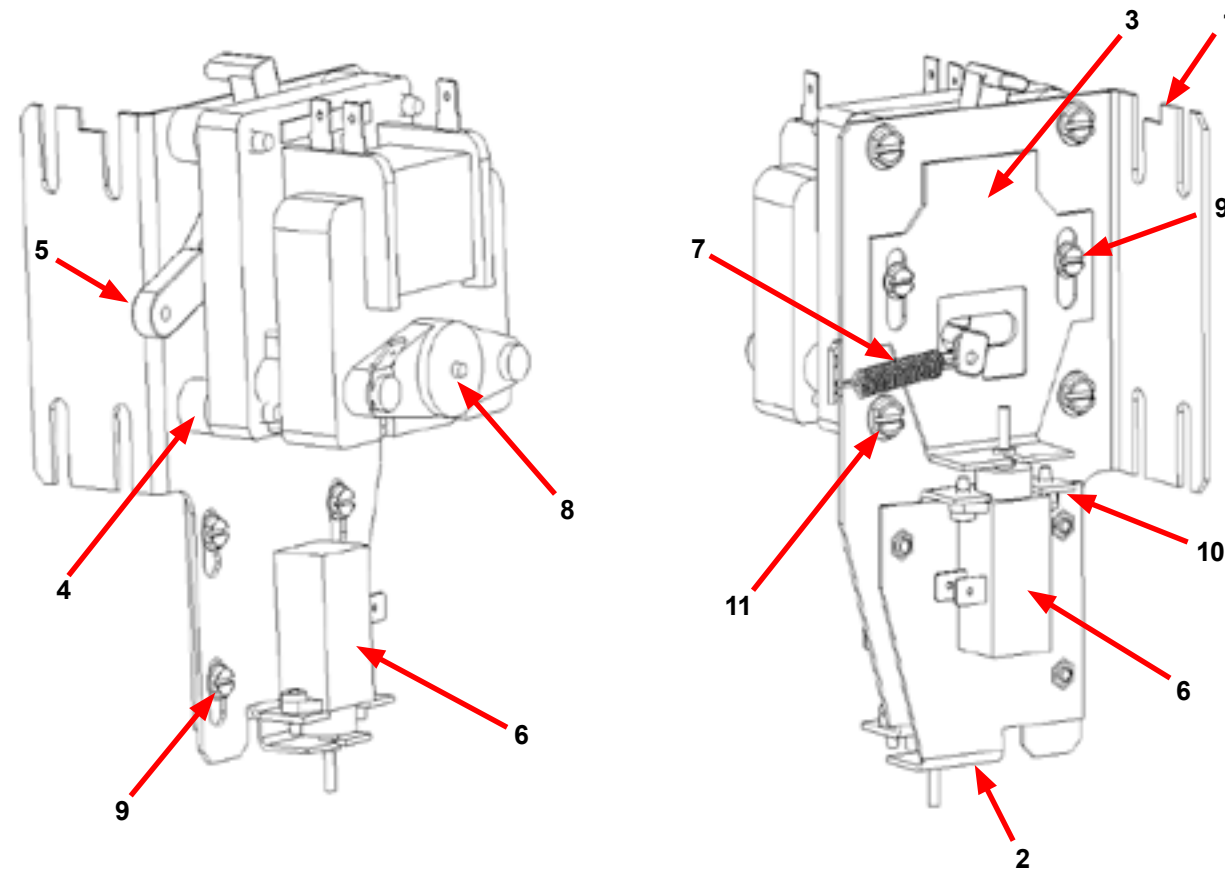

Key	Description	T-300	T-350	T-400	T-450	T-600	QTY
*	Actuator Assembly (Includes 1-10, Rod NOT included)	9892-015-002	9892-015-002	9892-015-002	9892-015-002	9892-015-002	1
1	Bracket Assy, Slide Lock Actuator	9985-190-001	9985-190-001	9985-190-001	9985-190-001	9985-190-001	1
2	Bracket Assy, Slide - Unlock	9985-189-001	9985-189-001	9985-189-001	9985-189-001	9985-189-001	1
3	Bracket Slide Lock	9029-204-001	9029-204-001	9029-204-001	9029-204-001	9029-204-001	1
4	Spacer, Plastic	9538-157-021	9538-157-021	9538-157-021	9538-157-021	9538-157-021	4
5	Arm - Door Lock	9001-063-001	9001-063-001	9001-063-001	9001-063-001	9001-063-001	1
6	Thermoactuator - Door Lock Relay 24VAC	9586-001-003	9586-001-003	9586-001-003	9586-001-003	9586-001-003	2
7	Spring - Extension	9534-350-001	9534-350-001	9534-350-001	9534-350-001	9534-350-001	1
8	Motor & Gear Assembly 24VAC	9914-137-014	9914-137-014	9914-137-014	9914-137-014	9914-137-014	1
9	Screw -Hxwshrdslsems, 6-32 x 3/16	9545-044-003	9545-044-003	9545-044-003	9545-044-003	9545-044-003	6
10	Cross Recessed PAN Hd Tapping screw	9545-031-011	9545-031-011	9545-031-011	9545-031-011	9545-031-011	4
11	Screw Phhdcr, 10-32 UNFx0.75	9545-012-029	9545-012-029	9545-012-029	9545-012-029	9545-012-029	4
*	Rod, Door Lock	9497-225-011	9497-225-011	9497-225-012	9497-225-012	9497-225-010	1
*	Spacer, Gear Motor	9538-187-001	9538-187-001	9538-187-001	9538-187-001	9538-187-001	1

CE Parts Group (-59) After Serial

Key	Description	T300	T350	T400	T450	T600	QTY
	Controls Assembly - Trough,	9839-018-001	9839-018-001	9839-018-001	9839-018-001	9839-018-001	1
	Circuit Breaker	5198-211-002	5198-211-002	5198-211-002	5198-211-002	5198-211-002	1
	Instructions, Transformer Connect	8507-449-004	8507-449-004	8507-449-004	8507-449-004	8507-449-004	1
	Controls Transformer	8711-004-004	8711-004-004	8711-004-004	8711-004-004	8711-004-004	1
	Transformer	8711-009-003	8711-009-003	8711-009-003	8711-009-003	8711-009-003	1
	Terminal Strip Marker	9558-028-002	9558-028-002	9558-028-002	9558-028-002	9558-028-002	1
	Line Reactor	9477-006-001	9477-006-001	9477-006-001	9477-006-001	9477-006-001	1
	Wiring Schematic & Diagram	9506-948-001	9506-948-001	9506-950-001	9506-948-001	9506-952-001	1
*	Do Not Enter/Confined Space Warning Label	8502-748-001	8502-748-001	8502-748-001	8502-748-001	8502-748-001	1
*	Do Not Operate w/ Gear Label	8502-748-003	8502-748-003	8502-748-003	8502-748-003	8502-748-003	2
*	Do Not Operate w/out Gear Label	8502-748-004	8502-748-004	8502-748-004	8502-748-004	8502-748-004	2
*	Elec. Shock Warning Label	8502-748-005	8502-748-005	8502-748-005	8502-748-005	8502-748-005	2
*	Explosive Material Warning Label	8502-748-006	8502-748-006	8502-748-006	8502-748-006	8502-748-006	1
*	Flammable Material Warning Label	8502-748-007	8502-748-007	8502-748-007	8502-748-007	8502-748-007	1
*	Lockout Warning Label	8502-748-008	8502-748-008	8502-748-008	8502-748-008	8502-748-008	1
*	Read Manual Warning Label	8502-748-009	8502-748-009	8502-748-009	8502-748-009	8502-748-009	2
*	Emergency Stop Label	8502-765-001	8502-765-001	8502-765-001	8502-765-001	8502-765-001	
*	Wiring Schematic/Diagram Label	9506-938-001	9506-938-001	9506-938-001	9506-938-001	9506-938-001	1
*	Operators Manual	8514-301-001	8514-301-001	8514-301-001	8514-301-001	8514-301-001	1

T-300 -59 Schematic

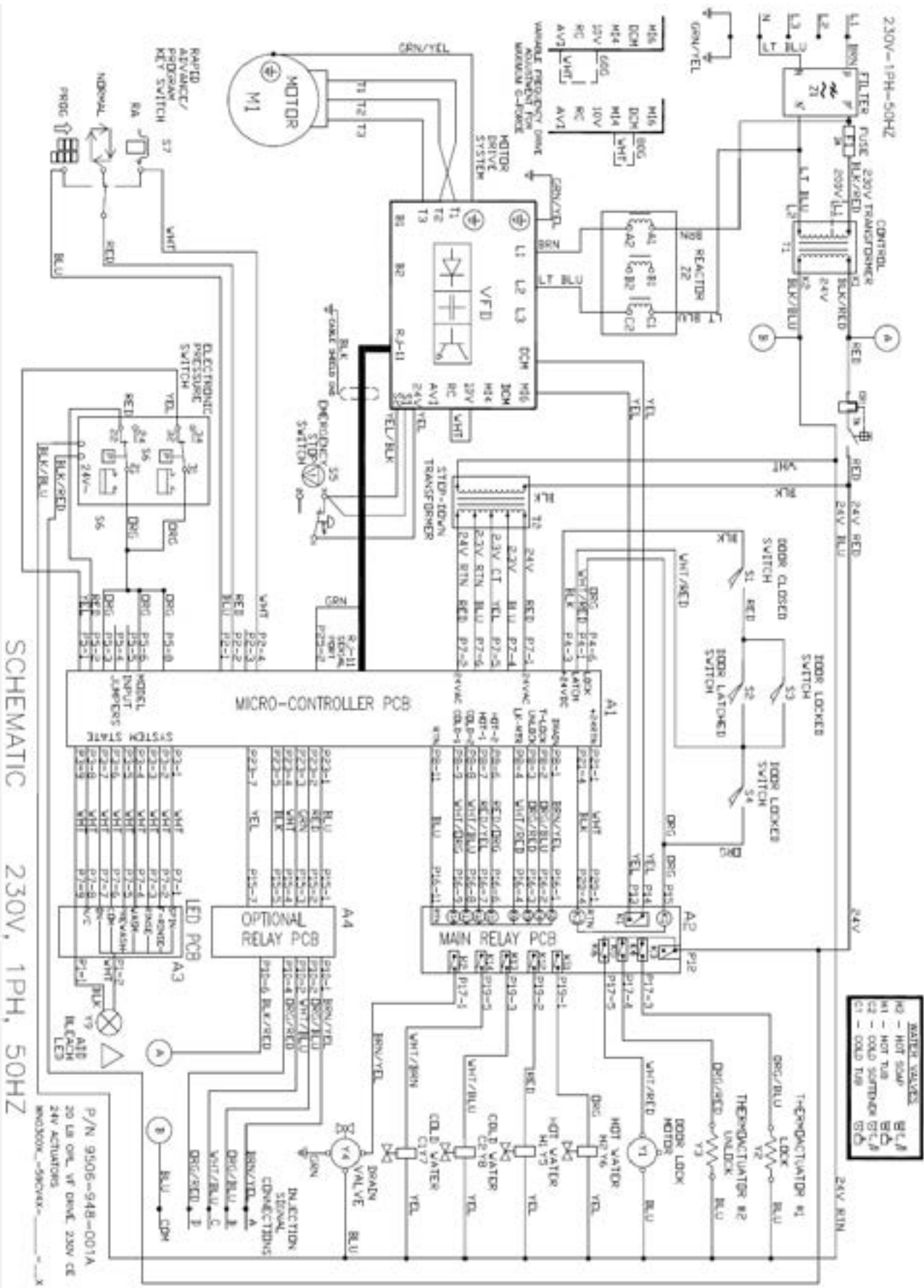

SCHEMATIC 230V, 1PH, 50HZ

T-350 -59 Schematic

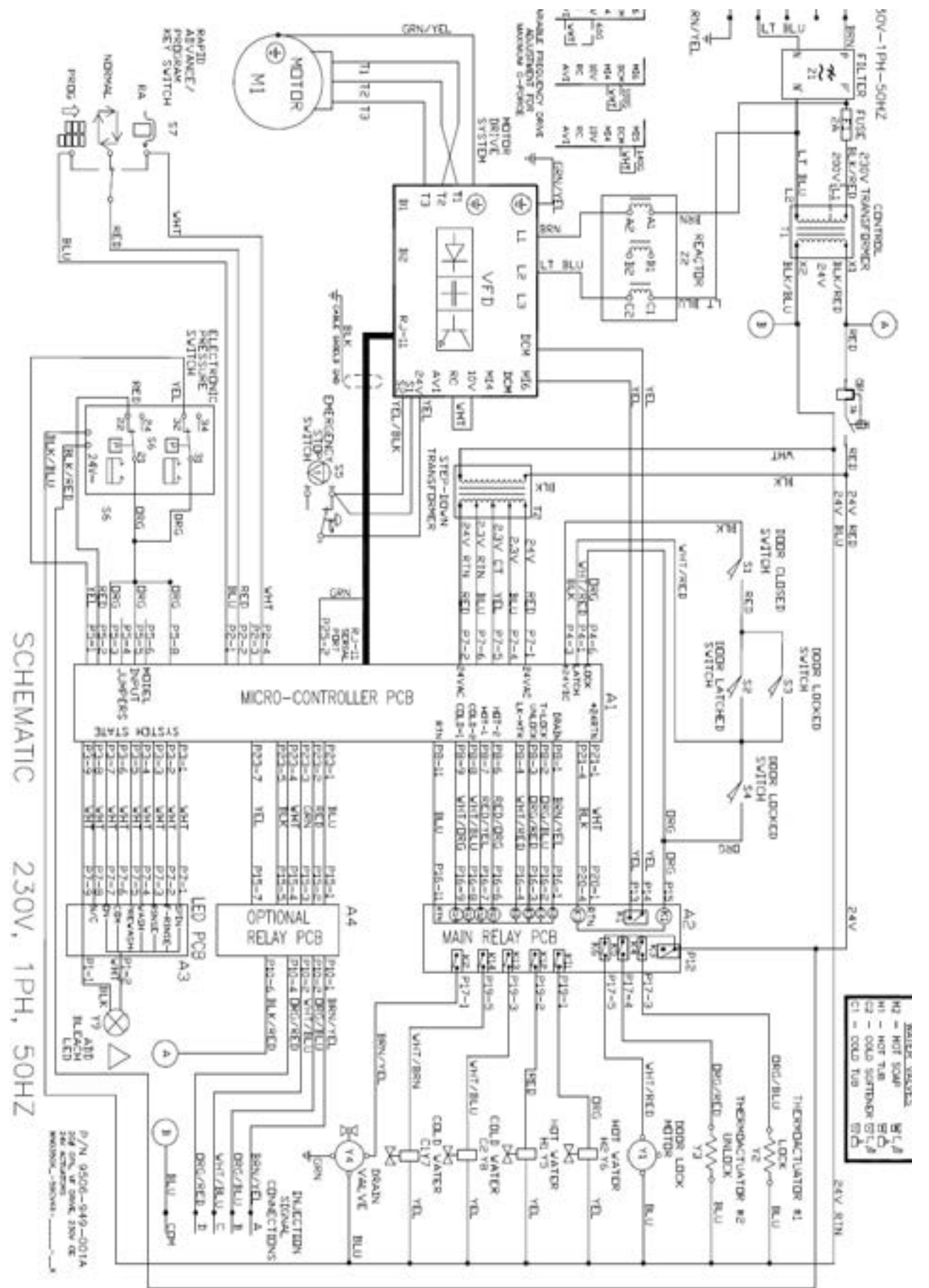

SCHEMATIC 230V, 1PH, 50HZ

T-400 -59 Schematic

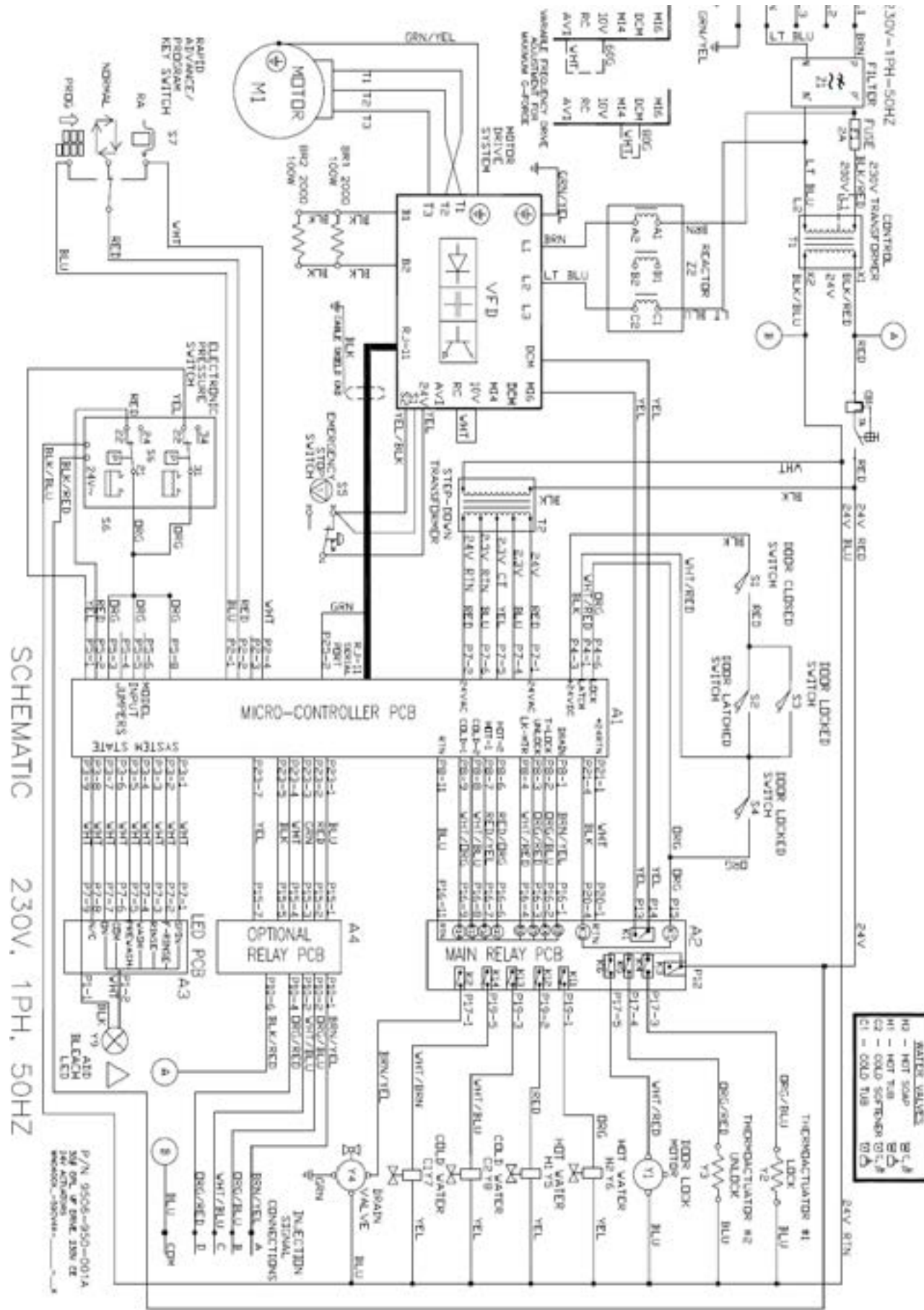

T-450 -59 Schematic

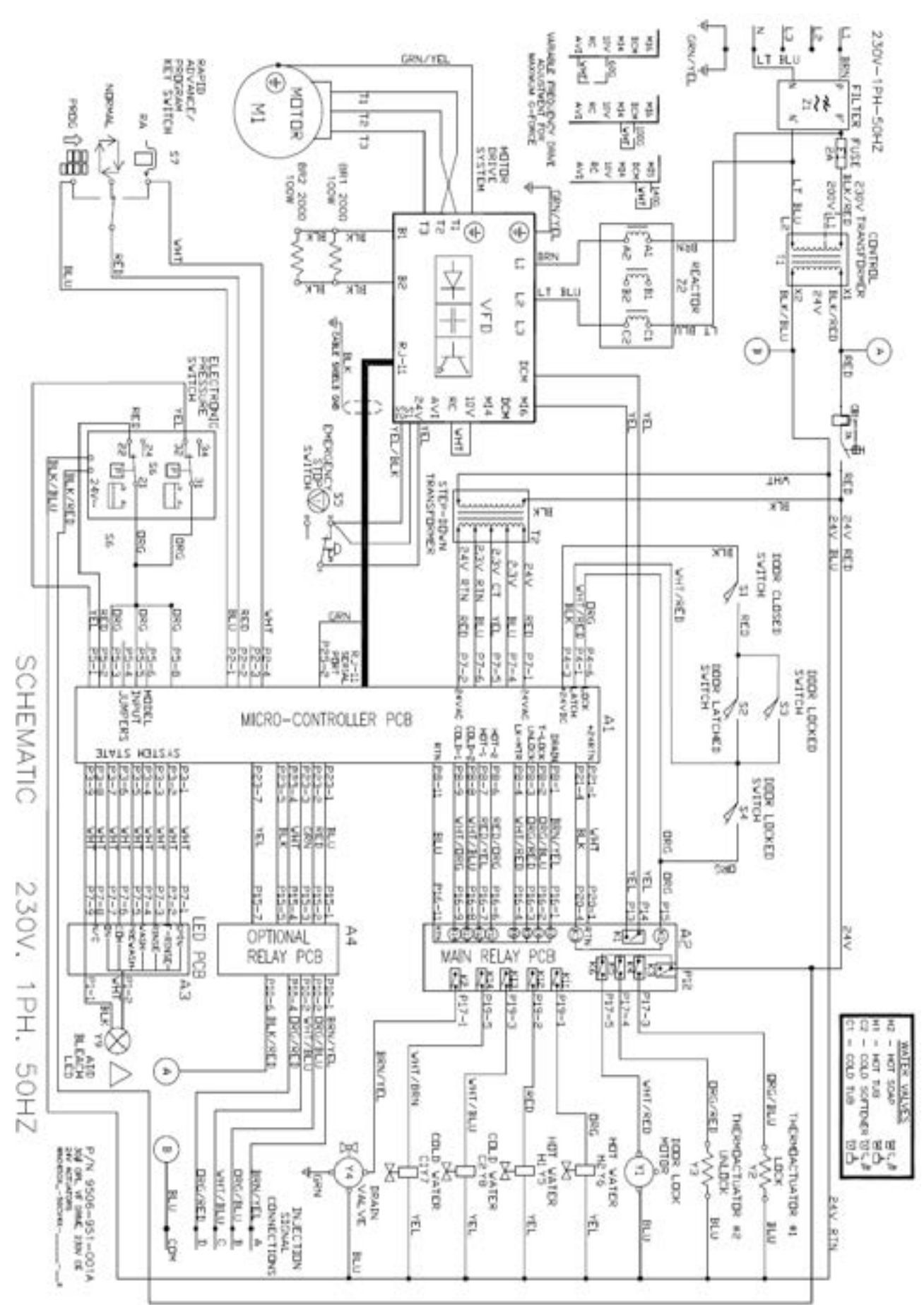

T-300-39 Schematic

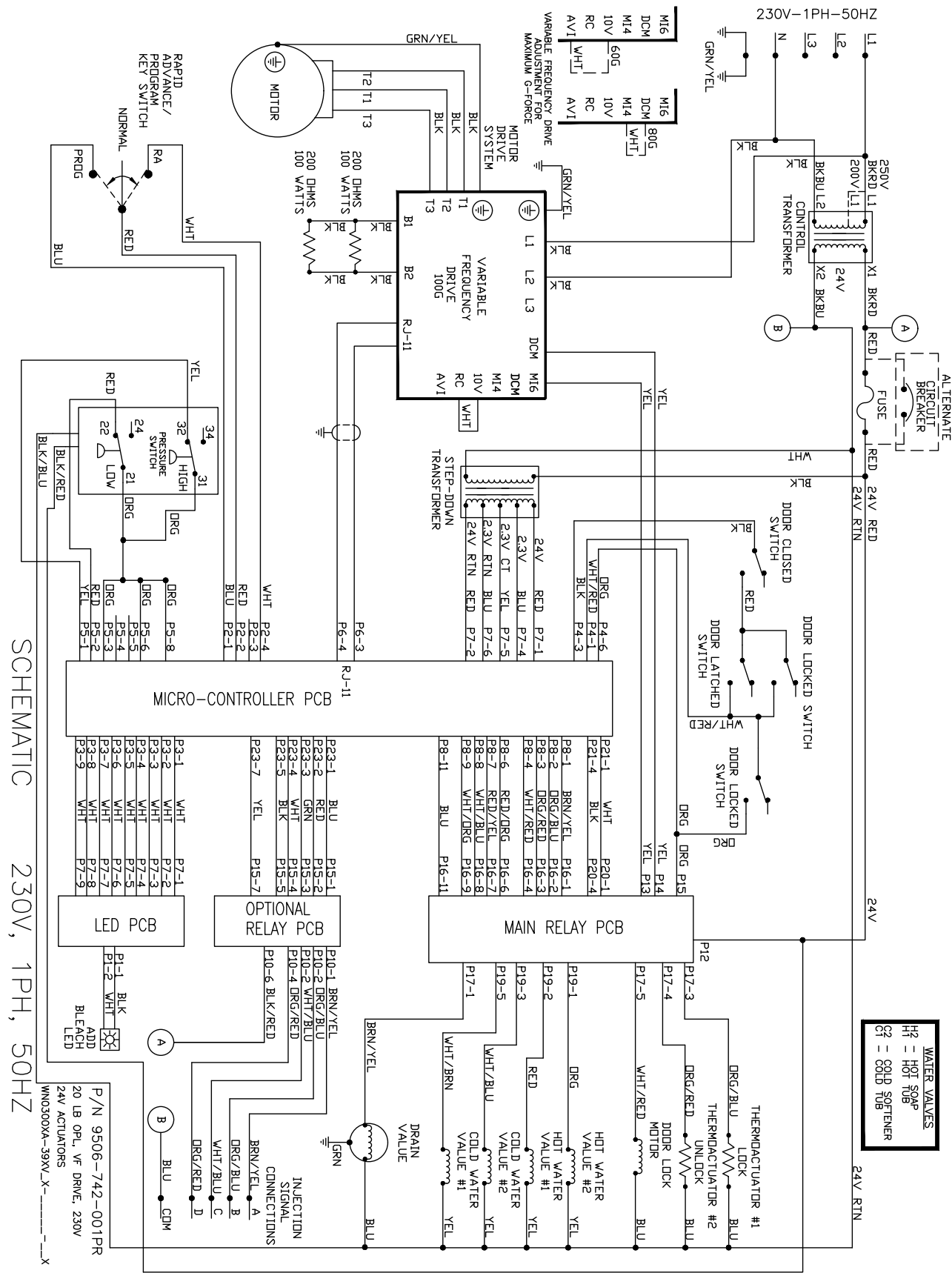

T-300-39 Diagram

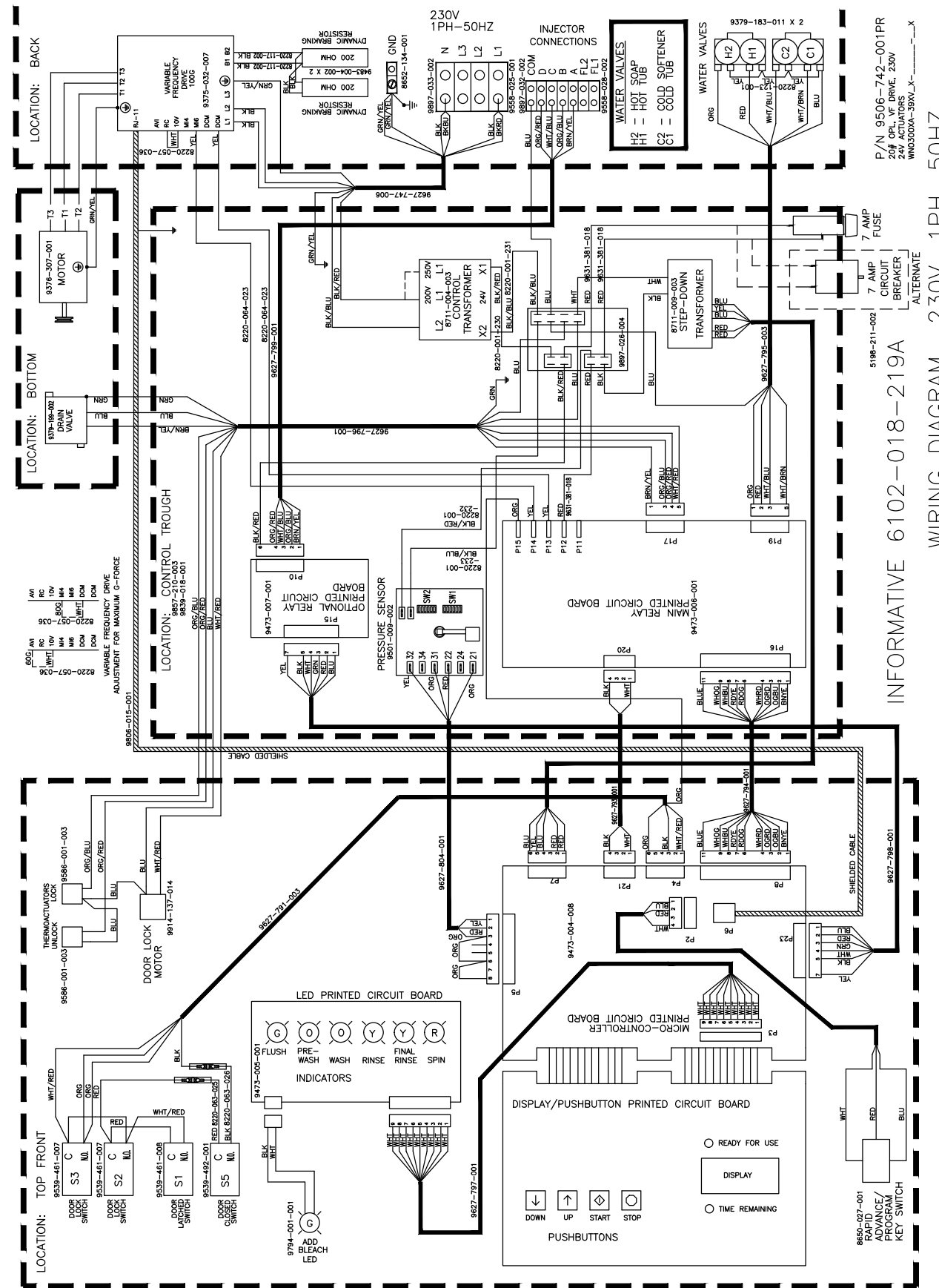

T-300-39 V4 Schematic

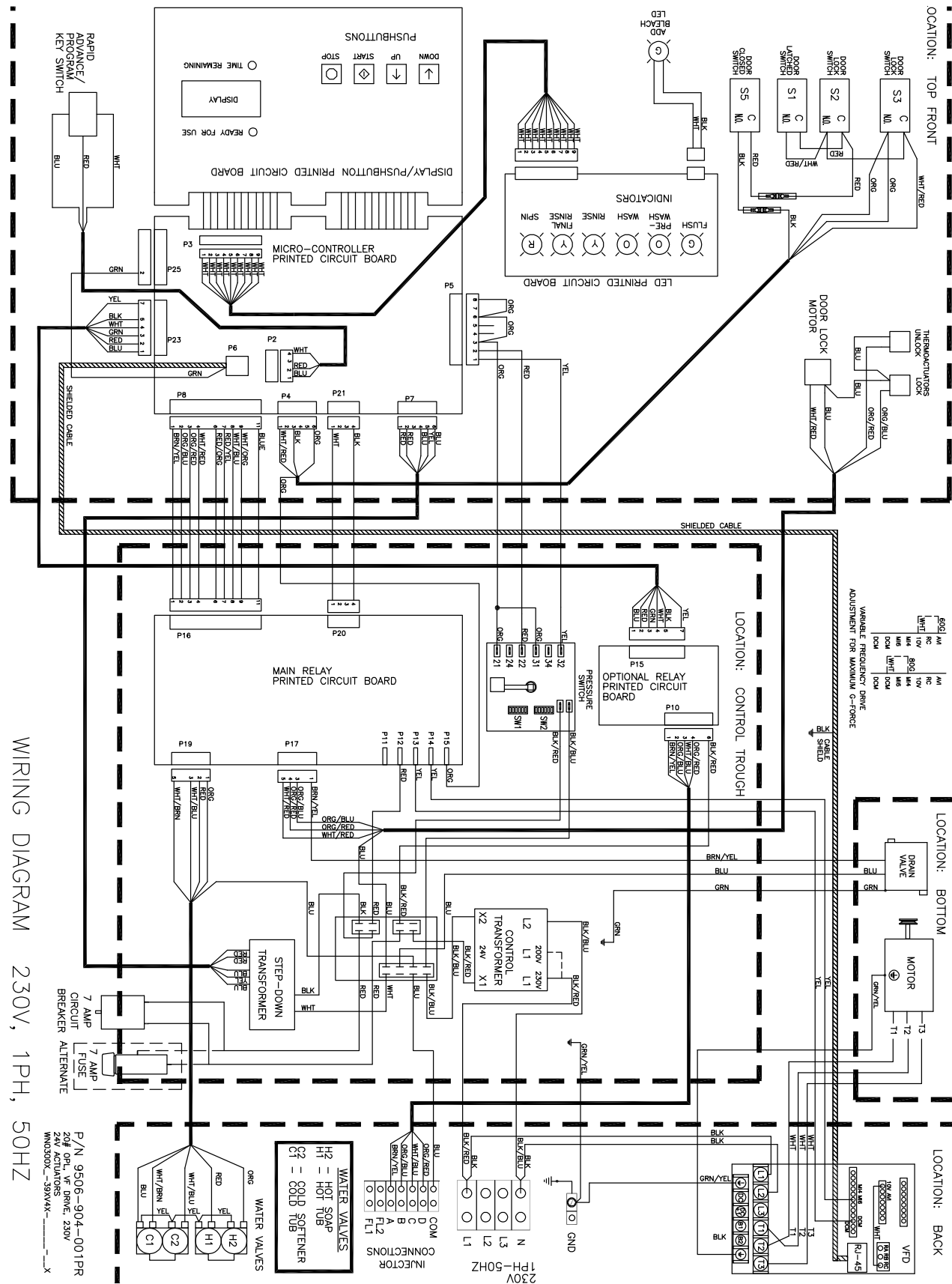

WIRING DIAGRAM 230V, 1PH, 50HZ

T-300-39 V4 Diagram

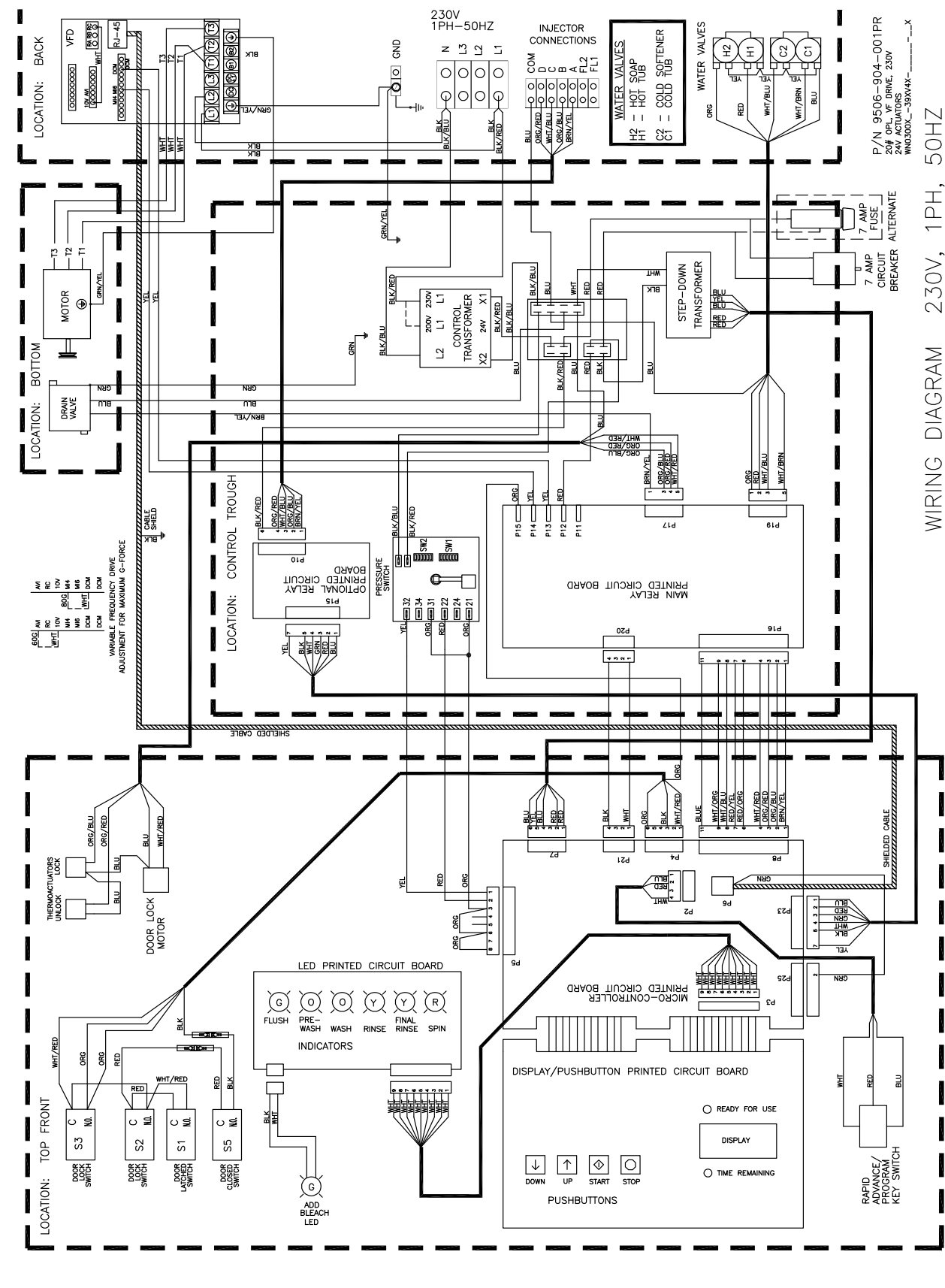

WIRING DIAGRAM 230V, 1PH, 50HZ

T-350-39 V4 Schematic

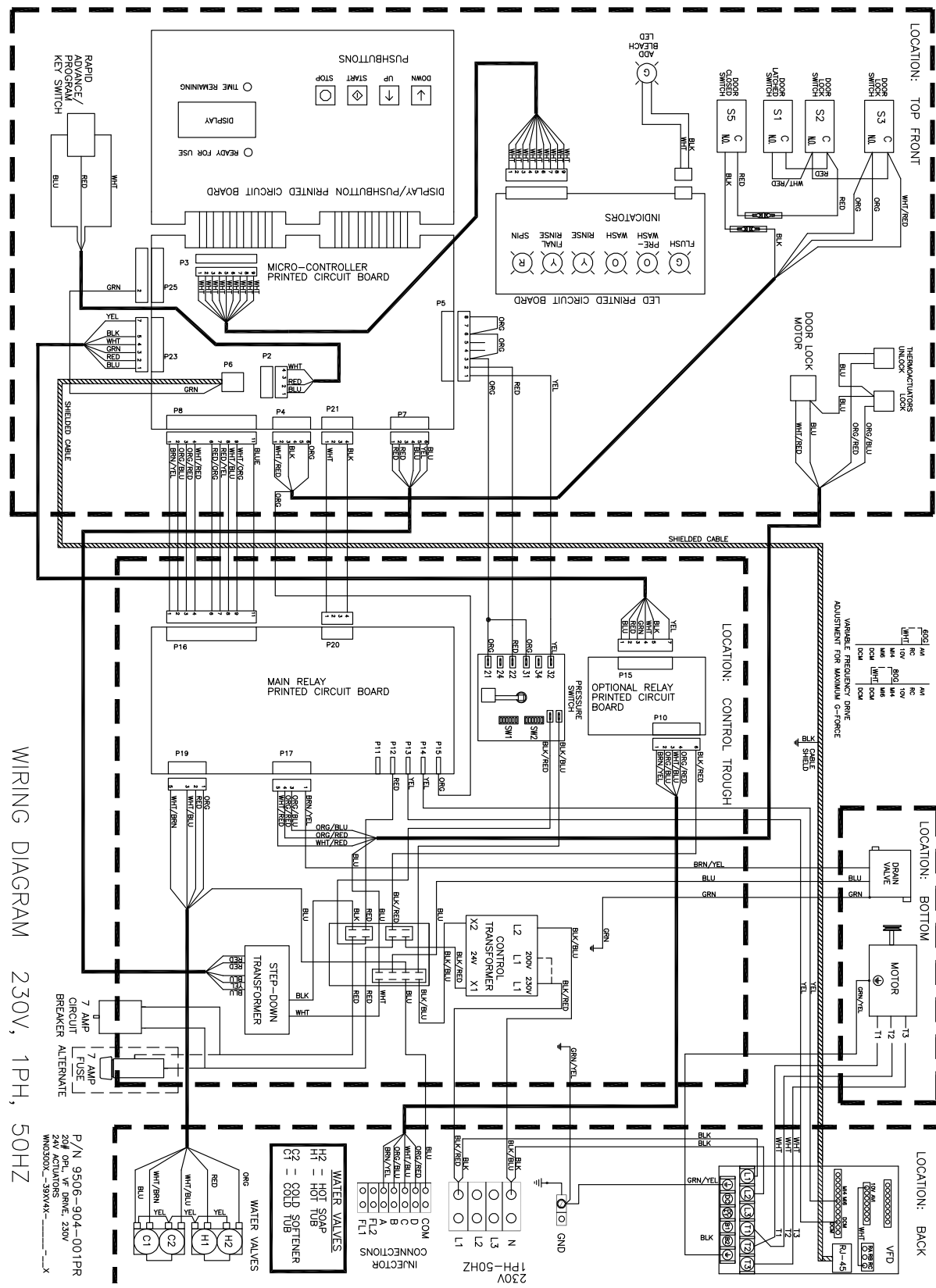

WIRING DIAGRAM 230V, 1PH, 50HZ

P/N 9506-904-001PR
20# OPL EXPRESS, VF DRIVE, 230V
WNO400VA-39V4_X
30# OPL EXPRESS, VF DRIVE, 230V
WNO400VA-39V4_X
WNO400VA-39V4_X
24V ACTUATORS

T-350-39 V4 Diagram

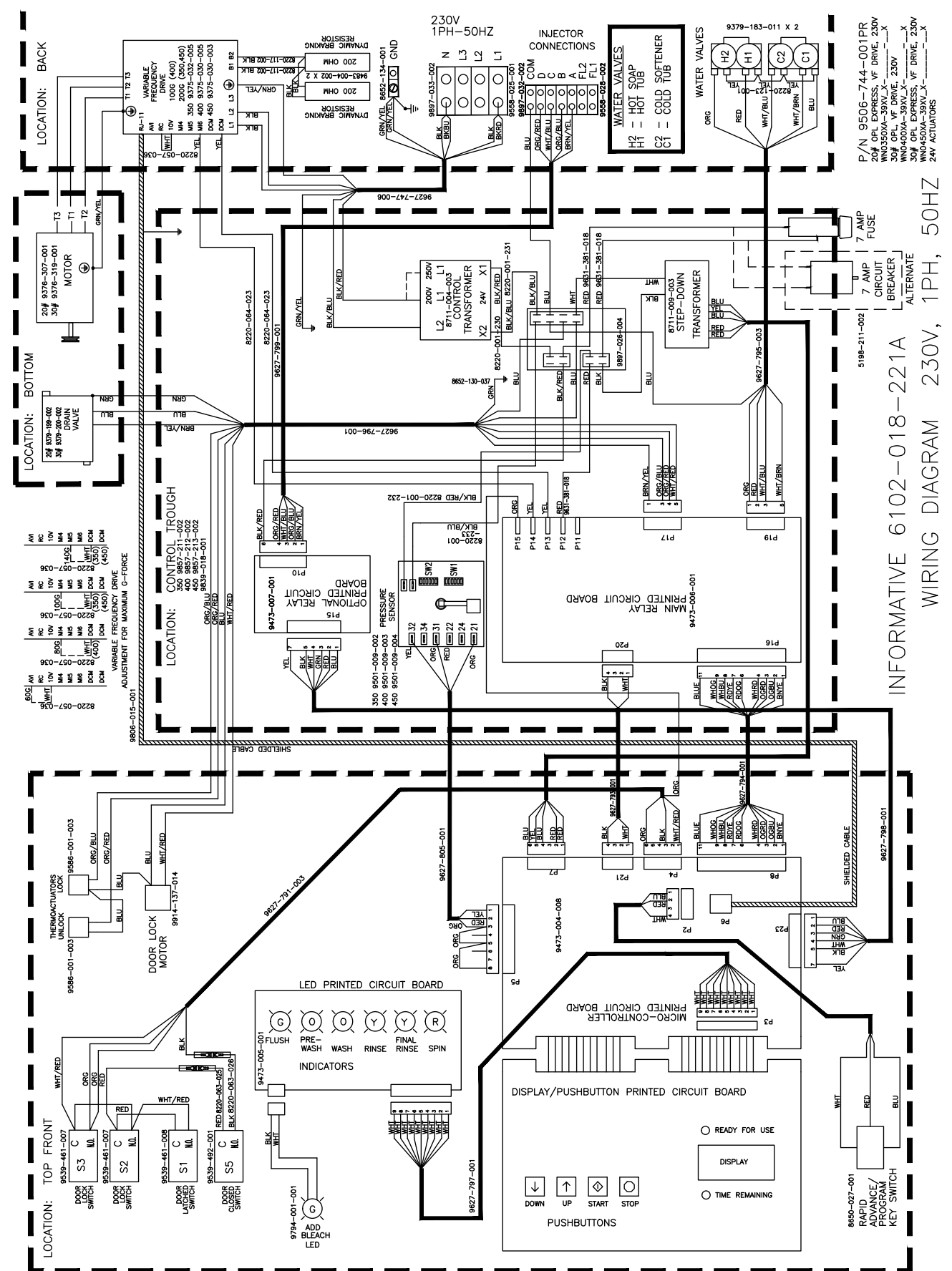

INFORMATIVE 6102-018-221A

WIRING DIAGRAM 230V, 1PH, 50HZ

P/N 9506-744-001PR
20# OPL EXPRESS, VF DRIVE, 230V
WNO400VA-39V4_X
30# OPL EXPRESS, VF DRIVE, 230V
WNO400VA-39V4_X
WNO400VA-39V4_X
24V ACTUATORS

T-400-39 V4 Schematic

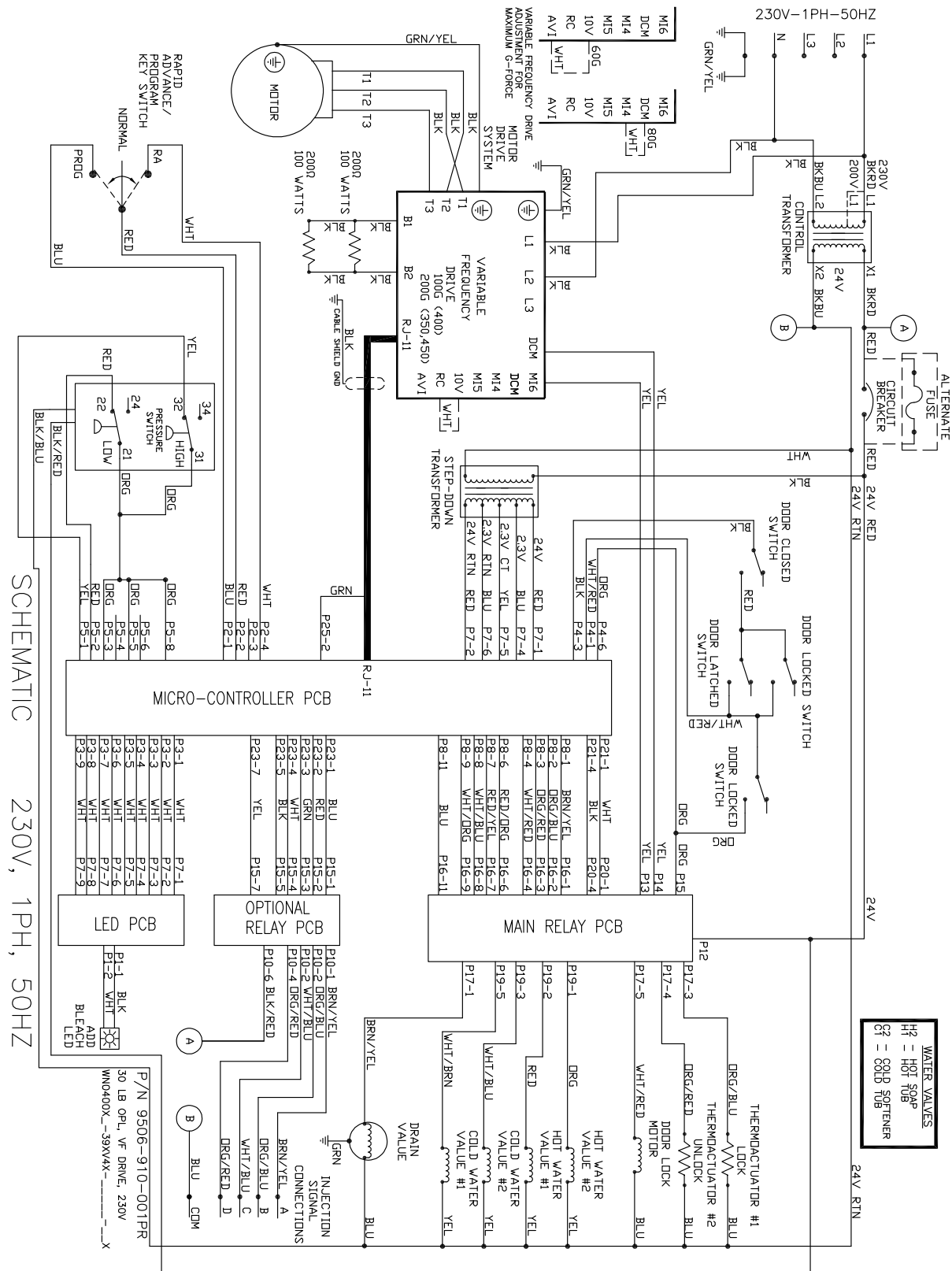

SCHEMATIC 230V, 1PH, 50HZ

T-400-39 V4 Diagram

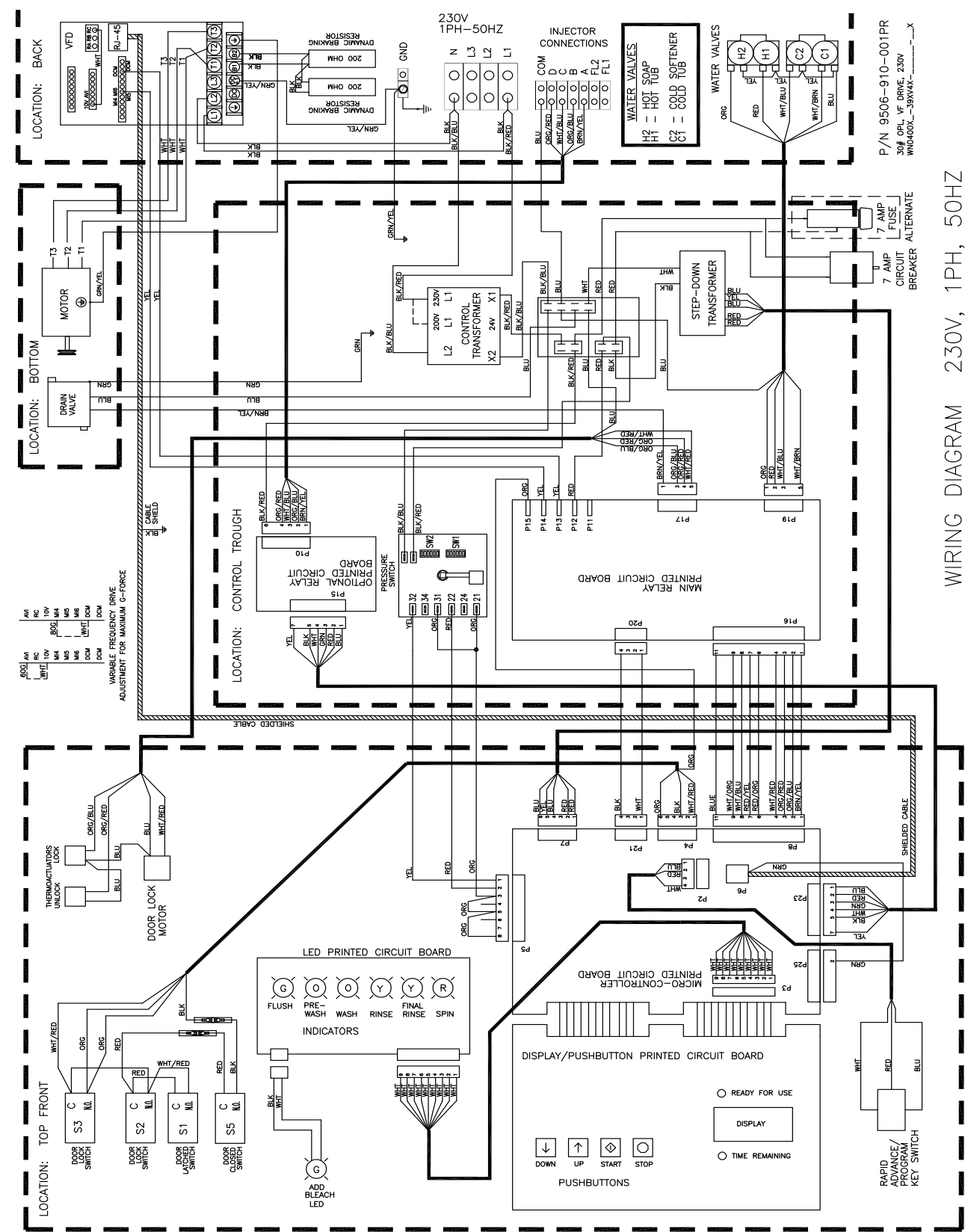

WIRING DIAGRAM 230V, 1PH, 50HZ

T-450-39 V4 Schematic

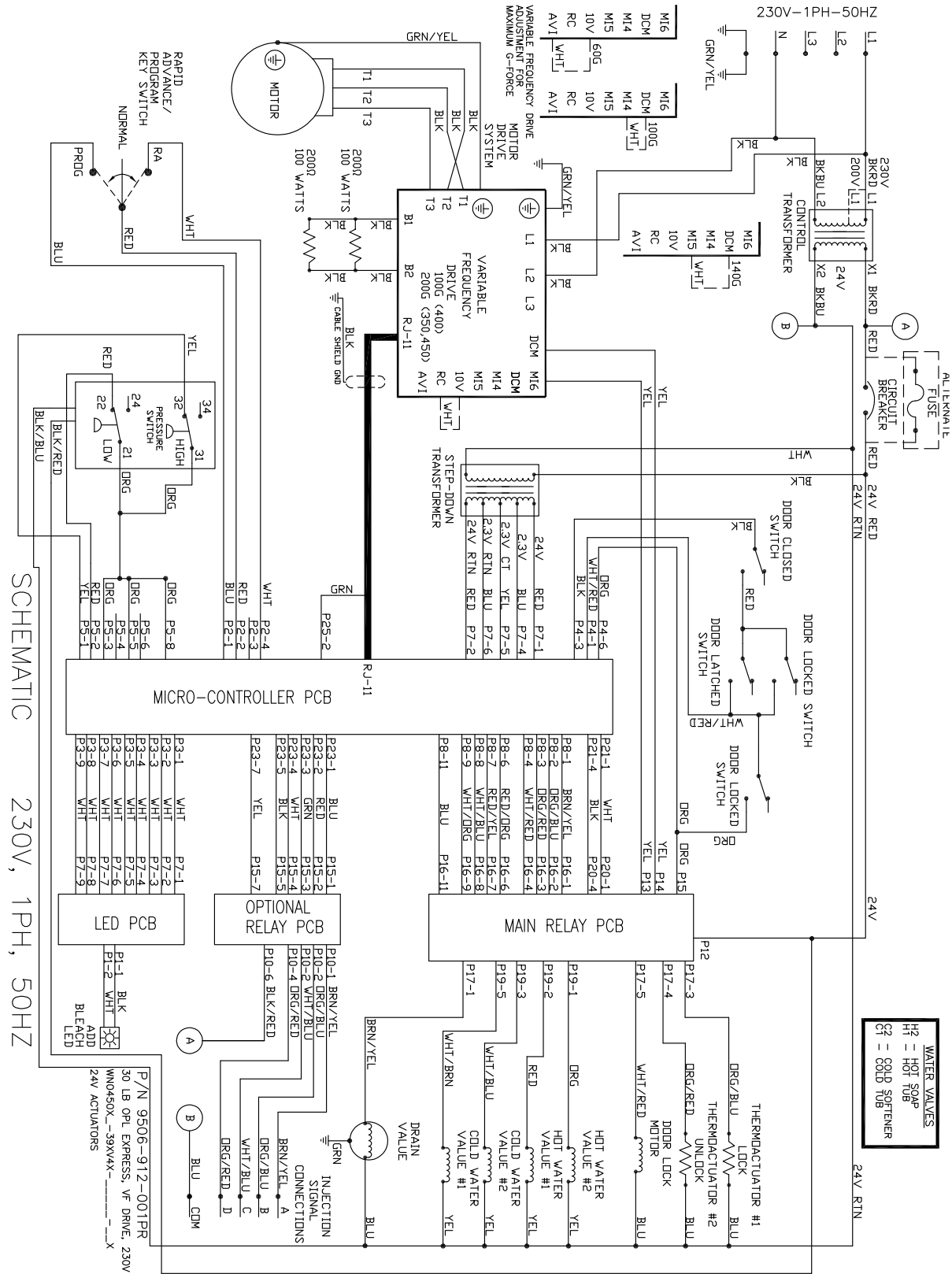

SCHEMATIC 230V, 1PH, 50HZ

T-450-39 V4 Diagram

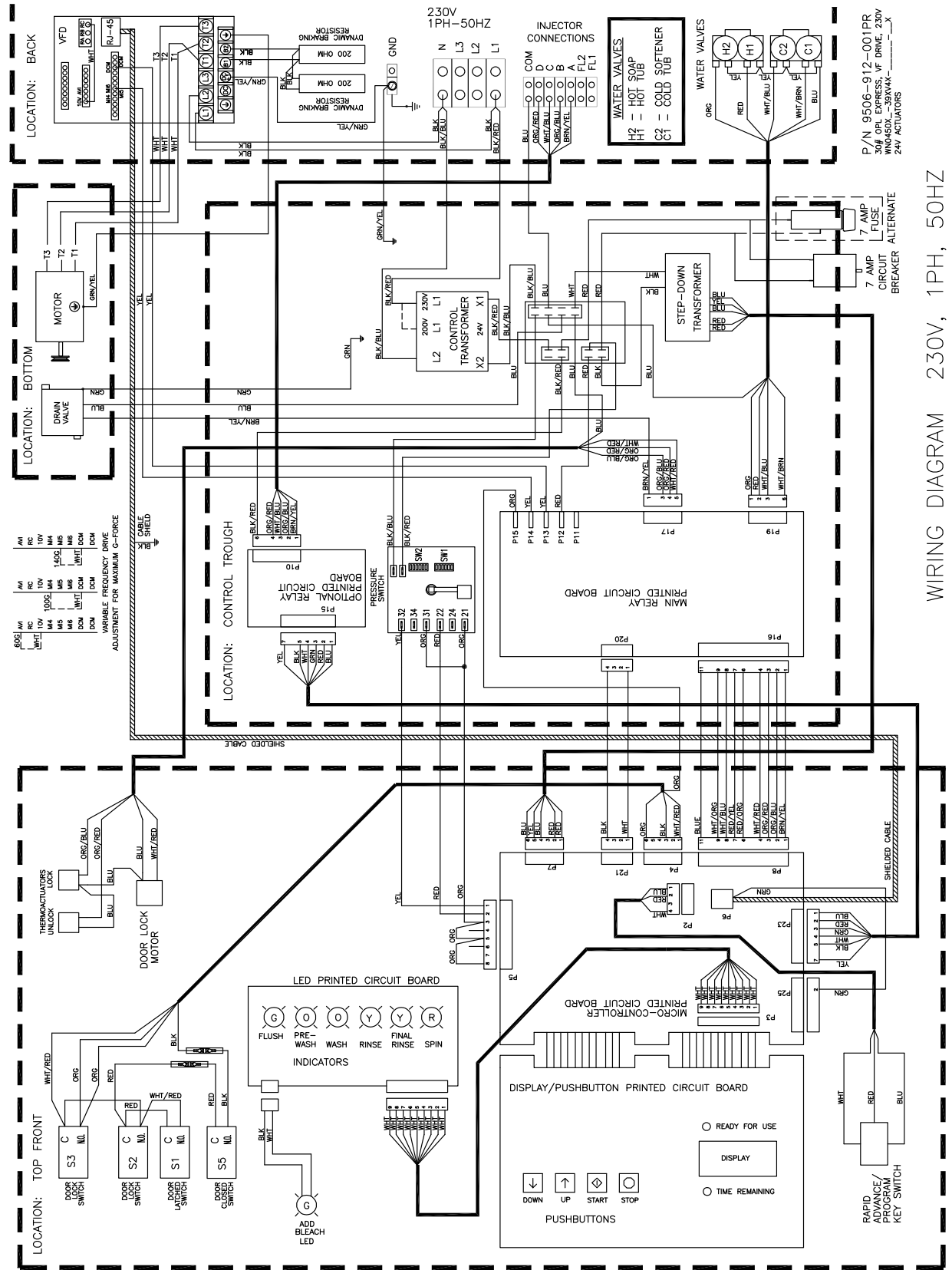

WIRING DIAGRAM 230V, 1PH, 50HZ

T-600-39 V4 Schematic

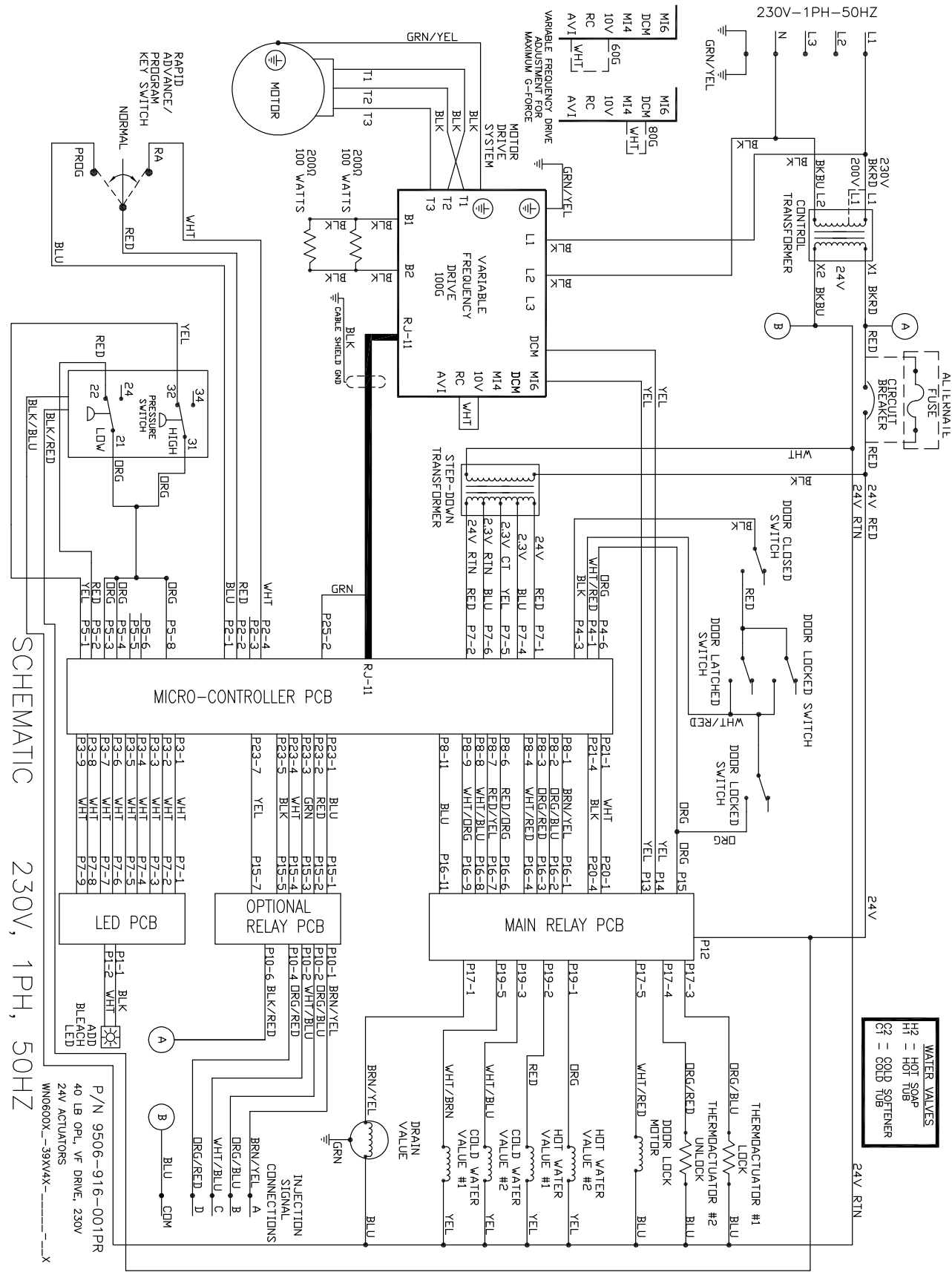

SCHEMATIC 230V, 1PH, 50HZ

T-600-39 V4 Diagram

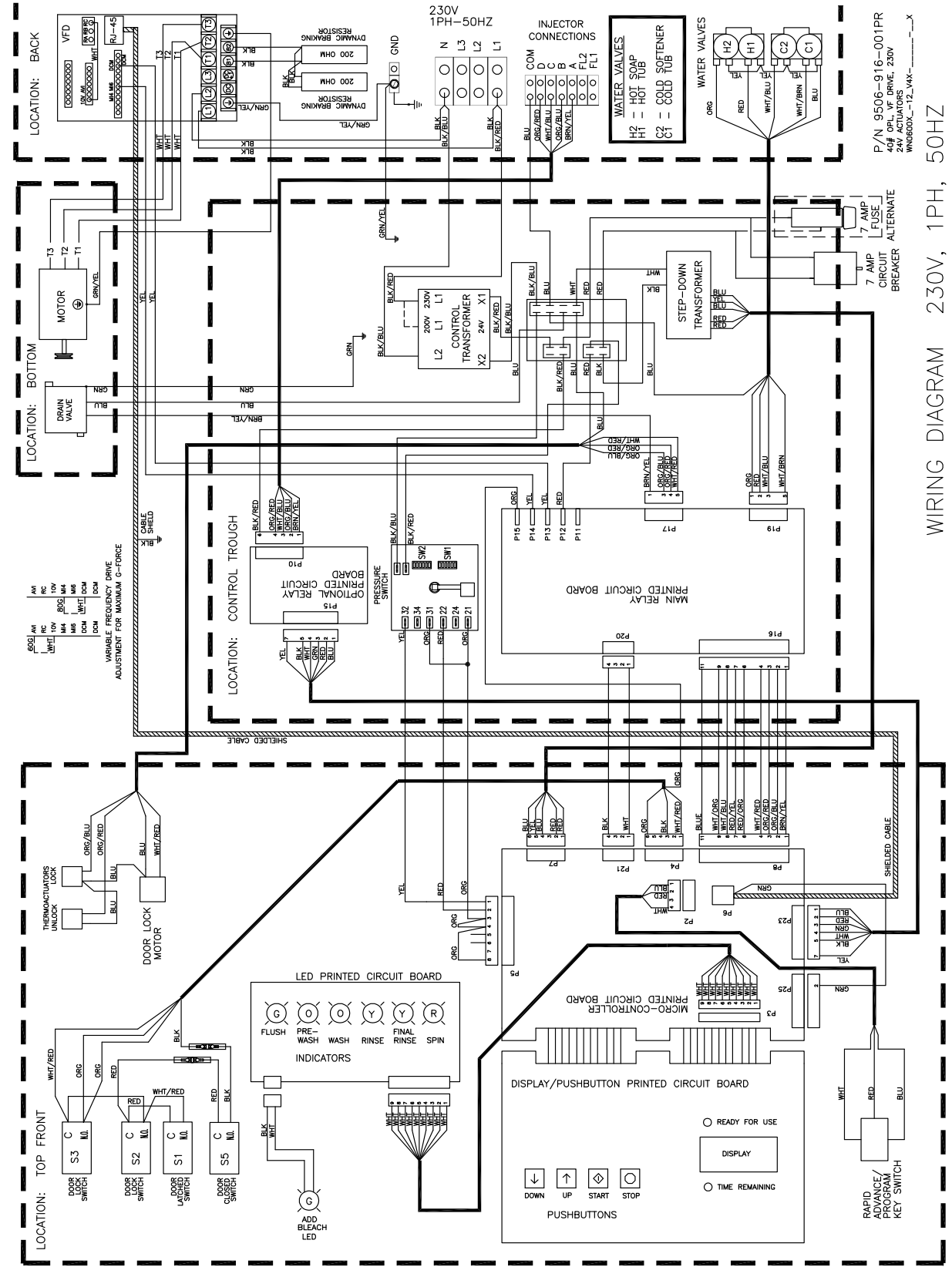

WIRING DIAGRAM 230V, 1PH, 50HZ