



***DEXTER***<sup>®</sup>  
***LAUNDRY***

**USE THE BLUE TABS LOCATED ON THE  
RIGHT AND LEFT SIDES OF THE FOLLOWING  
DOCUMENT TO ADVANCE TO EACH SECTION.**

## Kits, Assemblies, & Common Parts

Description	Part Number
LP to Natural Conversion Kit for White Rodgers	9732-142-004
LP to NG Conversion Kit for 9857-134-001 & -002	9732-142-002
Kit - A to C series Conversion, Black, 120v	9732-307-002
Kit - A to C series Conversion, Blue, 120v	9732-307-001
Kit - 8650-012-004 Lock with spacer	9732-344-002
Controls Assy, Black	9857-187-004
Ignition Control Box	9857-182-001
Thermostat, Hi-Limit	9576-203-002
Thermostat, Overtemp	9576-207-008
Fuseholder	9200-001-002
Fuse 1.5amp	8636-018-001
Motor Run Relay	5192-299-002
Transformer, Ignition	8711-013-001
Lint Screen	9555-057-008
Air Flow Switch	9536-461-009
Door Switch	9539-487-001
Drive Belt	9040-076-003
Spider/Trunnion	9568-017-001
Door Handle	9244-082-001



## Section 7:

Parts Data  
50# Stack

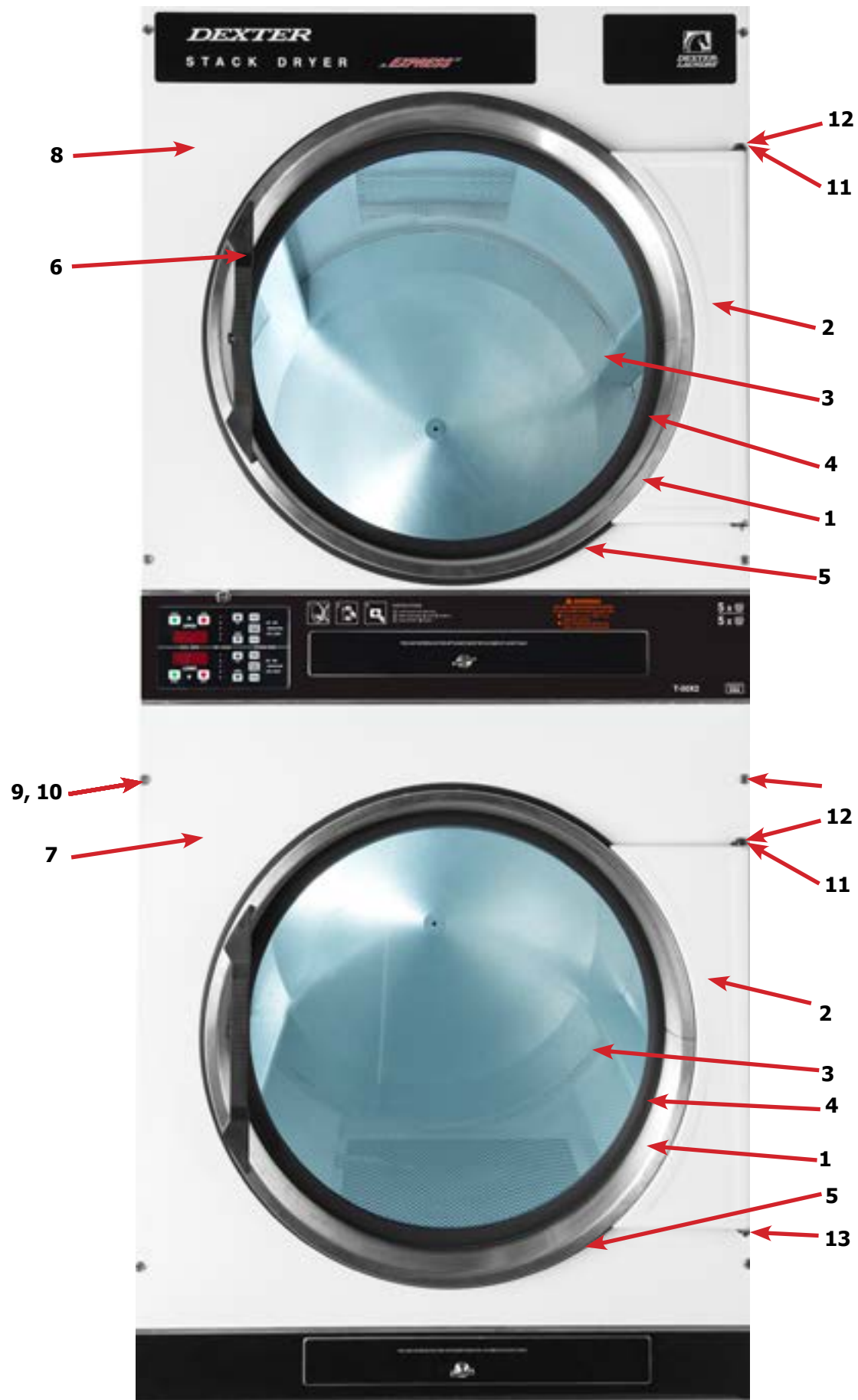

## Cabinet Group

Key	Description	T-50X2-11 Reversing	QTY
*	Door Assy., Loading Complete-Wht	9960-285-008	2
*	Door Assy., Loading Complete-SS	9960-285-011	2
1	Door Assy., Loading-SS(ring only)	9960-284-002	2
1	Door Assy., Loading-Chrome(ring only)	9960-284-004	2
1	Door Assy., Loading-Blk(ring only) (after D1.22290.005)	9960-320-004	2
2	Plate Assy., Hinge (Wht)	9982-353-002	2
2	Plate Assy., Hinge (SS)	9982-353-001	2
*	Screw, Hinge to Door	9545-012-015	8
*	Nut, Hinge to Door	8640-413-002	8
*	Cover, Hinge Plate	9074-340-002	2
*	Screw, Phillips-10B x 3/8	9545-008-010	4
3	Glass, Door	9212-002-004	2
4	Gasket, Glass Black	9206-413-002	2
*	Support, Door Glass	9548-117-000	2
*	Tool Install Dryer Door Gasket	8545-064-001	1
5	Gasket, Outer Rim Black	9206-420-005	2
6	Handle, Loading Door	9244-082-001	2
*	Screw, Handle 1/4-20 x 3/8	9545-018-017	4
*	Stud, Door Catch, 7/8	9531-033-003	2
*	Nut, Hex	8640-413-001	2
*	Nut, Acorn	8640-413-003	2
*	Catch, Loading Door	9086-015-002	2
*	Pop Rivet for mtg. catch	8638-190-009	4
*	Lockwasher	8641-582-006	4
*	Spring Nut (Before Serial D1.21180.036)	8640-399-001	6
*	Expansion Nut (After Serial D1.21180.036)	8640-442-001	6
7	Panel Assy., Front- Lower (Wht)	9989-517-011	1
7	Panel Assy., Front- Lower (SS)	9989-517-009	1
8	Panel Assy., Front- Upper (Wht)	9989-517-015	1
8	Panel Assy., Front- Upper (SS)	9989-517-013	1
*	Insulation Front Panel, half moon (top)	9277-054-001	2
*	Insulation Front Panel, half moon (bottom)	9277-054-002	2
9	Screw, FLHDCR, 10B x 1	9545-008-014	14
*	Finish Washer	8641-585-001	6
*	Spring Nut (Before Serial D1.21180.036)	8640-399-001	12
*	Expansion Nut (After Serial D1.21180.036)	8640-442-001	12
11	Strap, Hinge (SS/Black)	9544-069-005	2
*	Screw, Hinge to Panel	9545-012-028	8
12	Screw, Door to Hinge Strap (Special Black Type)	9545-052-001	2
13	Washer, Fiber	8641-436-003	2
*	Switch, Door Closed	9539-487-001	2
*	Cabinet Touch Up Paint (White)	9472-001-013	1

## Cabinet Group Continued

Key	Description	T-50X2-11 Reversing	QTY
15	Escutcheon, Upper	9994-050-001	1
16	Trim, Overlay-Upper Black	9435-044-001	1
17	Escutcheon, Lower	9994-051-001	1
18	Trim, Overlay-Lower Black	9435-031-001	1
*	Screw, #4-40 x 3/16	9545-020-009	20
19	Nameplate Stack Dryer Express Black	9412-167-001	1
*	Lint Drawer Assembly Black	9866-005-005	2
20	Overlay Trim, Lint Drwr-Black	9435-032-002	1
*	Felt Seal (back of lint screen assembly)	9532-143-001	2
*	Lint Screen Assembly ONLY (no front)	9805-033-002	2
*	Replaceable Lint Screen Only	9555-057-008	2
21	Lock-Door, Service (thumb turn), Lint Drawer	8650-026-002	2
*	Cam, Lock	9095-044-001	2
*	Strap, Screen (Sides)	9544-092-001	4
*	Strap, Screen (Front)	9544-089-001	2
*	Strap, Screen (Rear)	9544-090-001	2
*	Lint Screen Strap Hold Down Screws 10Bx 1/4	9545-008-001	32
22	Controls Assy, Black	9857-187-004	1
*	Harness, Electronic Control	9627-885-002	1
23	Lock and Key, Control	8650-012-003	1
*	Cam, Lock	9095-041-001	1
*	Key only (6324)	6292-006-007	1
*	Harness, Heat Sensor	9627-886-001	1
*	Wire Nut Connector Grey	8640-276-002	4
24	Sensor Temp Control	9501-004-004	2
*	Bracket for Heat Sensor Mounting (Under Basket) w/ sensor	9501-008-002	2
*	Screw, Round Head (Mounts sensor; phillips head)	9545-045-005	2
*	Grommet, 3/16 ID	9209-037-002	2
*	Leg, Leveling 1/2"	8544-006-001	4
*	Leveling Leg Wrench	8545-061-002	1
*	Cover, Cabinet (Top)	9074-320-001	1
*	Insulation Cabinet Cover	9277-041-017	1
*	LP Kit for 50Lb Stk Dryers	9732-102-013	1
*	Strap - Bead Tie	9544-041-002	1
*	Screws, Mounting-Coin Vault	9545-008-024	2

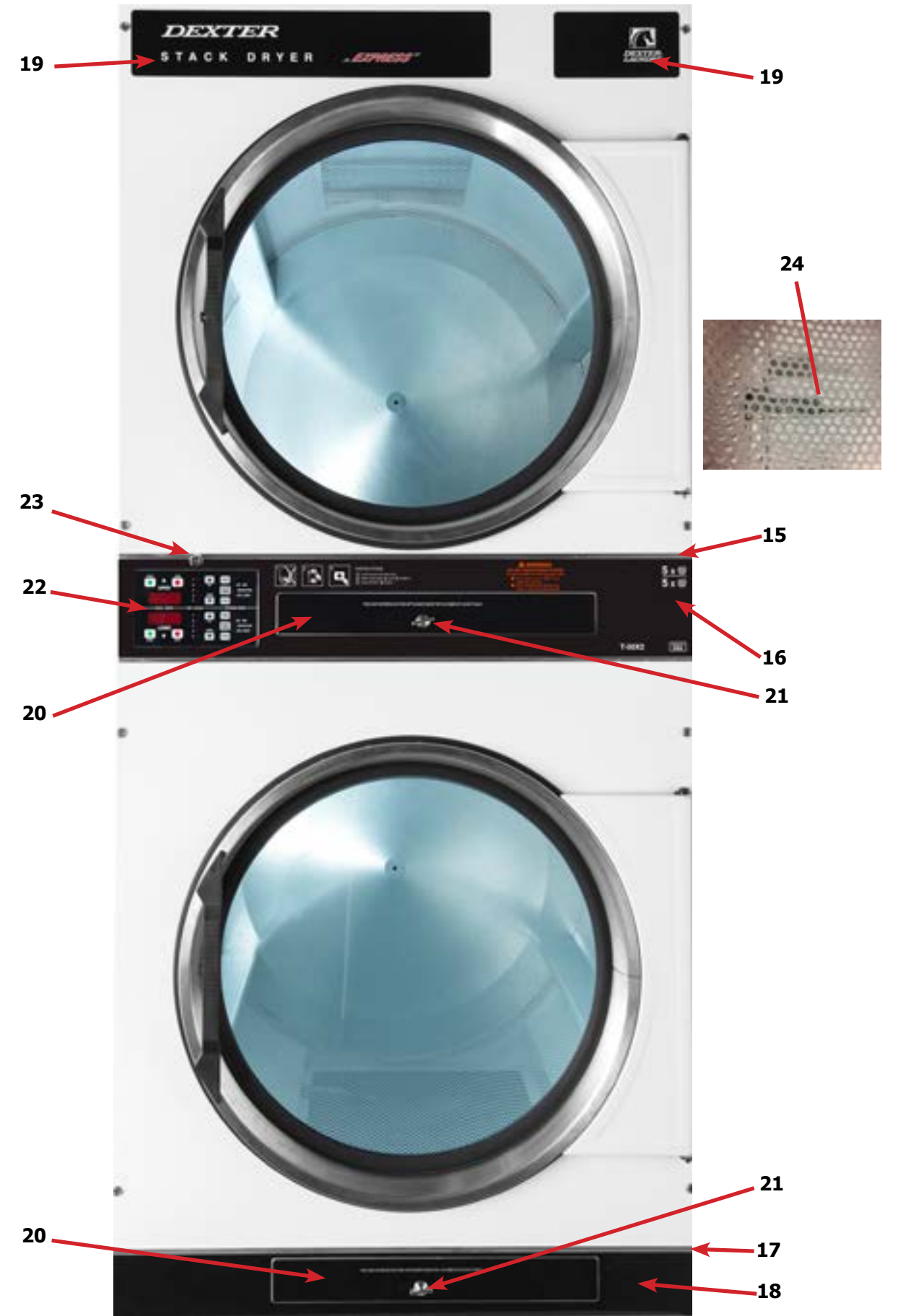



## Rear View Photos

Key	Description	T-50X2-11 Reversing	QTY
1	Pulley, Driven	9908-047-002	2
*	Tolerance Ring	9487-234-005	2
2	Washer-Flat, 1/2"	8641-581-026	2
3	Lock Washer, 1/2"	8641-582-016	2
4	Bolt, 1/2"-13 x 1" 1/4"	9545-017-009	2
5	Belt, Drive	9040-076-003	2
6	Air Flow Switch, Assembly	9801-098-001	2
7	Motor-Drive, 2Hp.	9376-319-001	2
8	Pulley-Motor, Drive	9453-169-012	2
*	Screw-Set, 5/16"-18 x 1/2"	9545-028-013	4
9	Rod-Motor Mounting	9497-222-008	2
*	Bushing, Motor Support	9053-074-002	4
10	Collar-Shaft, w/Set Screw	9076-052-002	2
11	Spring, Belt Tension	9534-319-002	2
12	Chain, Spring Tension, 15 1/2" (27 Links)	9099-012-008	2
13	Hook, "S" Hook	9248-022-002	2
14	Drive-VFD, Inverter, 2Hp 230VAC	9375-032-011	2
*	VFD Cooling Fan	9189-013-001	1
*	Assembly, Impeller-Blower Motor (15-17)	9919-019-001	2
15	Plate Assembly, Impeller-Blower Motor	9982-388-002	2
*	Nut, 5/16"-18	8640-400-003	8
*	Impeller, w/Set Screws	9278-043-001	2
16	Motor, Blower	9376-311-005	2
17	Bolt-Motor Mounting, 5/16, 18 x 5/8"	9545-014-004	8
18	Nut-1/4" x 20, Mounting Plate, Impeller Motor Assy.	8640-414-007	14

## Rear View Photos

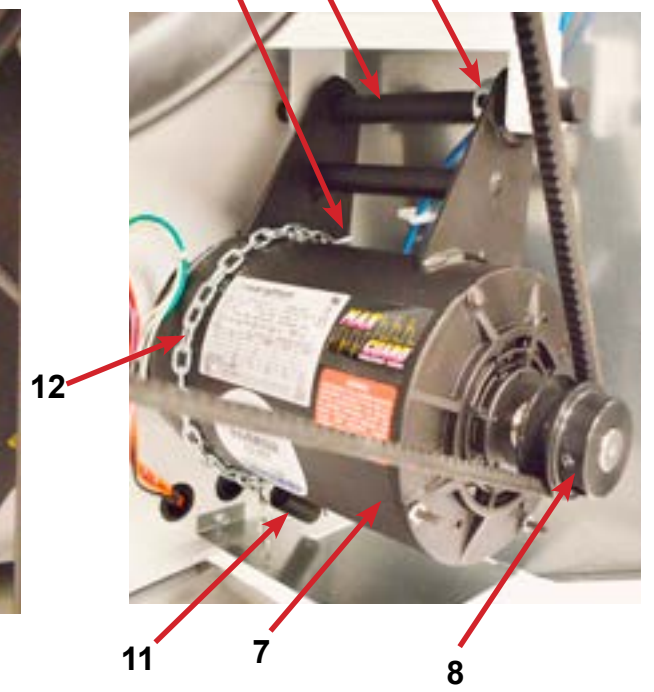
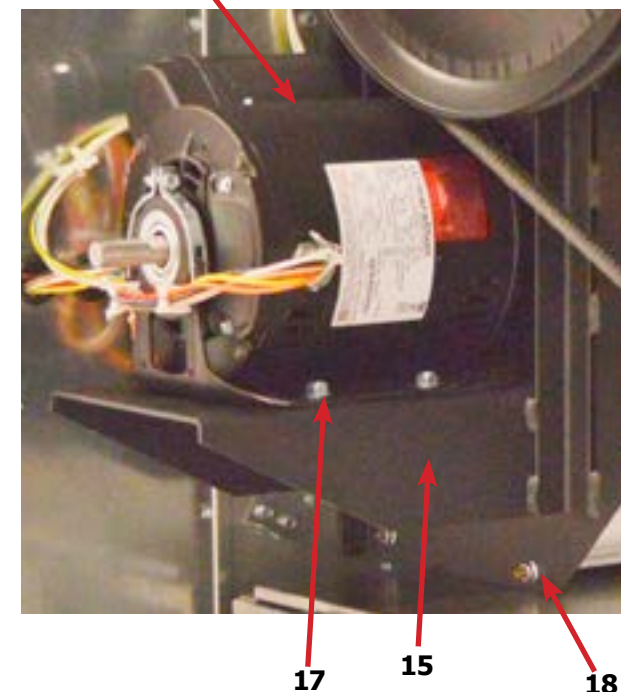
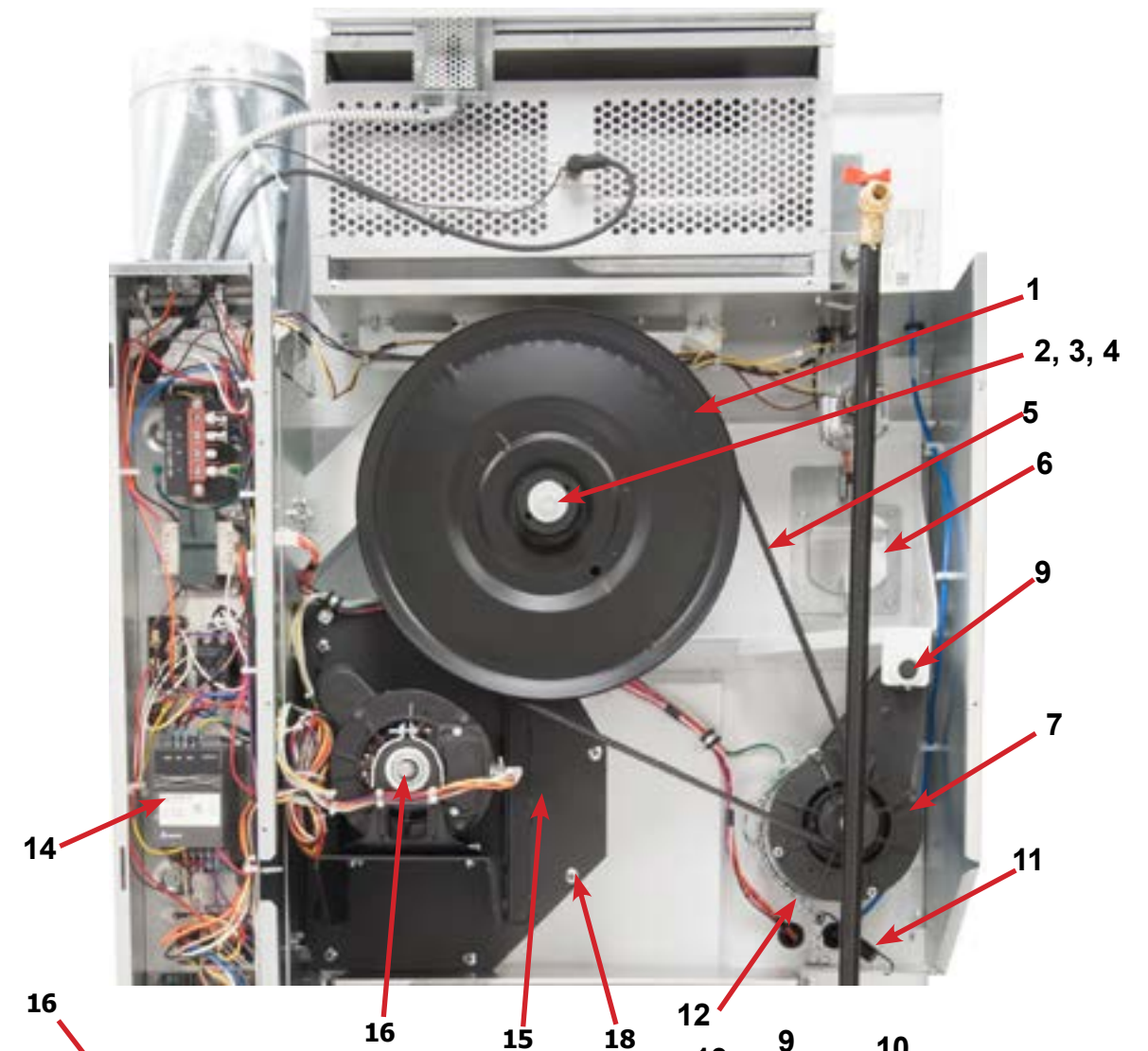



## Bearing Housing Group

Key	Description	T-50X2-11 Reversing	QTY
	Bearing Housing Complete Assy (Includes bearings & Spacer)	9803-201-001	1
1	Housing, Bearing	9241-189-002	1
*	Bearing, Ball, Front	9036-159-001	1
*	Spacer, Bearing	9538-183-001	1
2	Bearing, Ball, Rear	9036-159-003	1
3	Screw-Wizlock, 1/2-13x3/4	9545-017-017	4
4	Nut, 1/2-13	8640-417-002	4
5	Screw, 1/2-13x1 1/2	9545-017-018	2

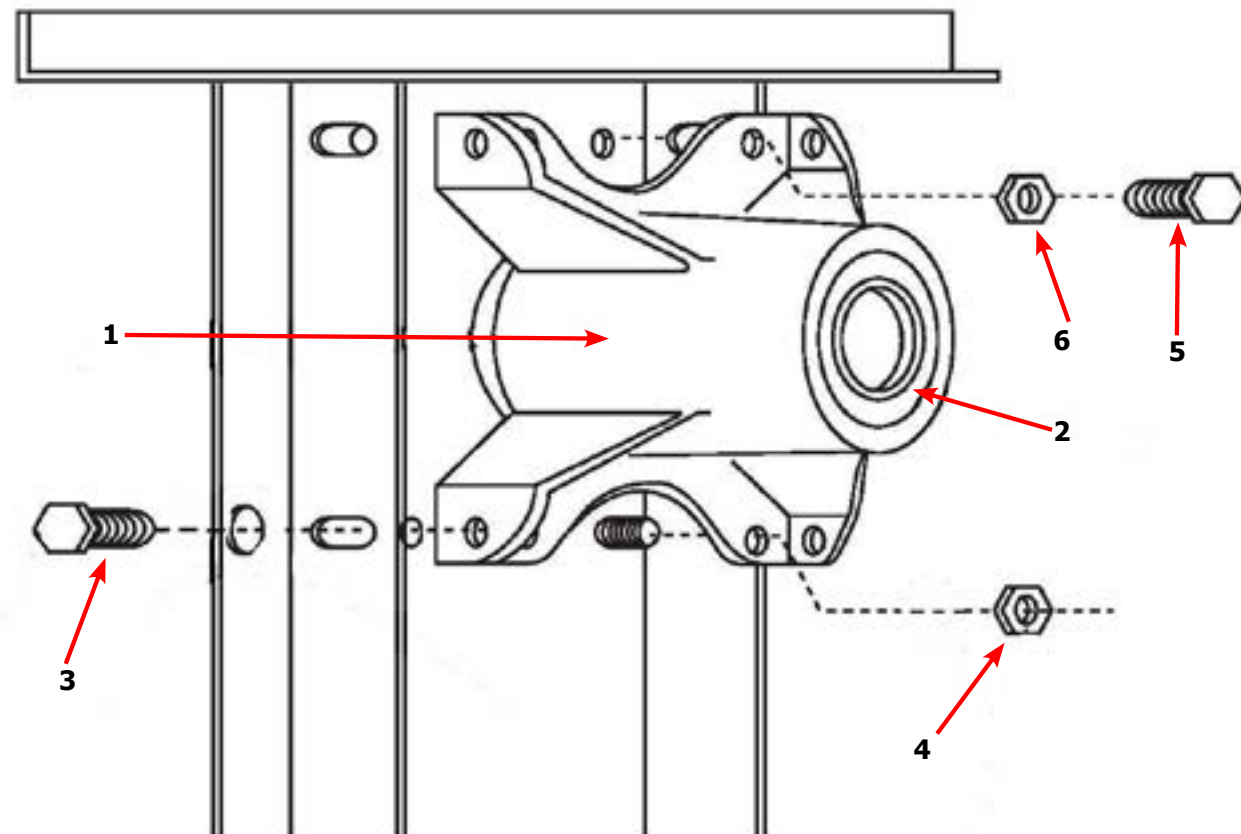

## Tumbler Group

Key	Description	T-50X2-11 Reversing	QTY
*	Tumbler Assy Complete W/Spider (GALV)	9848-154-001	1
1	Tumbler Assy (Galvanized)	9848-148-001	1
*	New Tumbler, Taller Baffles (Anti-Roping) W/Spider	9848-158-001	1
*	New Tumbler, Taller Baffles (Anti-Roping)	9848-157-001	1
*	Tumbler Assy Complete W/Spider (SS & Galv front)	9848-154-002	1
1	Tumbler Assy (Stainless Galvanized front)	9848-148-002	1
2	Rod, Tumbler	9497-226-002	3
3	Washer, Special	8641-590-002	3
4	Shim	9552-013-003	AR
5	Spider Assy	9568-017-001	1
6	Nut, Wiz Lock	8640-417-005	3
7	Spacer-Shaft	9538-188-001	1
8	Tolerance Ring	9487-234-005	1
9	Pulley, Driven	9908-047-002	1
10	Washer -Flat	8641-581-026	1
11	LockWasher - IntTooth, 1"	8641-582-016	1
12	Screw, 1/2-13x1 1/4	9545-017-009	1
*	Belt, Drive	9040-076-003	2

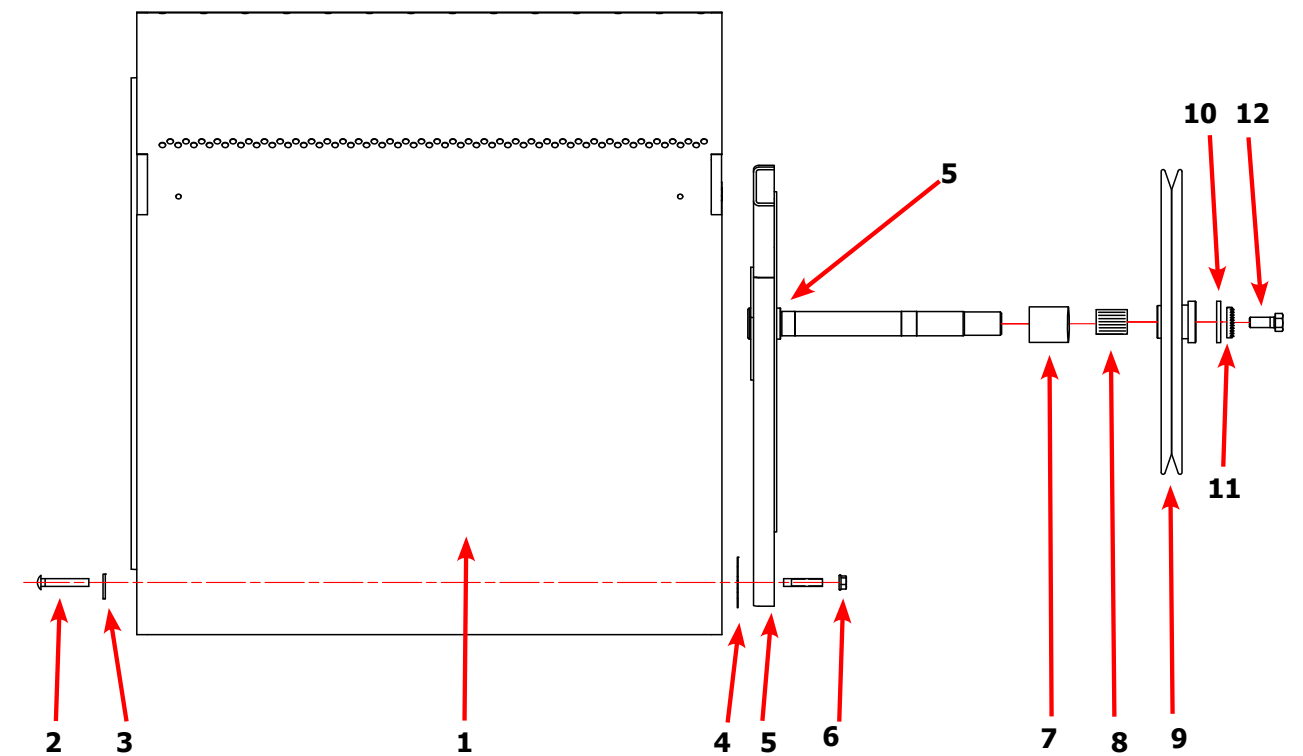



## Burner Housing Group

Key	Description	T-50X2-11 Reversing	QTY
*	Housing Assembly, Burner	9803-230-001	2
1	Service Burner Plate Front	9452-730-001	2
2	Service Plate baffle Recirculation Chamber Clean Out	9452-850-001	2
*	Screw, 10B x 3/8"	9545-008-006	8
3	Screw, 10B X 1/4"	9545-008-001	16
4	Angle, Burner Support	9003-220-001	2
*	Screw, 10B x 3/8"	9545-008-006	4
5	Burner, Main	9048-020-002	4
*	Screw 10AB x 3/8"	9545-008-006	4
*	Panel, Burner- Front & Back	9454-822-001	2
6	Panel, Burner Housing, Side (RH)	9454-790-001	2
7	Panel, Burner Housing, Side (LH)	9454-826-001	2
8	Panel, Burner Housing, Top	9454-805-001	2
9	Shield-Heat, Burner Top	9550-198-001	2
10	Electrode Assy, Ignition	9875-002-003	2
11	Screw, Electrode Mtg 8B x 1/4"	9545-045-001	4
12	Valve, Gas Shut Off (Optional)	9379-196-001	1
13	Control Assy, Gas	9857-192-001	2
14	Manifold, Assy	9381-012-001	2
*	Orifice, Burner-Natural #29	9425-069-021	4
*	Orifice, Burner-LP #46	9425-069-022	4
15	Bracket, Manifold	9029-175-001	4
16	Pipe Plug in end of Burner Manifold	8615-104-038	2
*	Screw, 10B x 3/8"	9545-008-006	4
17	Thermostat, Hi-Limit	9576-203-002	2
*	Spacer, Hi-Limit	9538-142-001	2
*	Screw 8B x 3/4"	9545-045-007	6
18	Cover, Hi-Limit Stat Ignitor	9074-329-001	2
19	Bracket-Hilimit	9029-192-001	2
*	Screw, 10B x 3/8"	9545-008-006	4
*	Thermostat, Safety Shutoff	9576-207-008	2
*	Screw, 10B x 3/8"	9545-008-006	6
20	Cover, Safety Stat	9825-062-001	2
*	Screw, 10AB x 3/8	9545-008-024	6
*	Control, Ignition Fenwall (3 trybox)	9857-182-001	2
*	Kit, LP Conversion 50Lb Stack Kit (White Rodgers)	9732-102-045	1
*	Welded One Piece Gas Pipe Assembly w/Shutoff Valve	9838-018-003	1
*	Gas Pipe Assembly Replacement Kit	9732-360-003	1
*	Gas Pipe Assembly (After Serial)	9838-023-003	1
*	Fitting - 1/2 NPT Union Adapter	8615-120-001	1
21	Heat Recirculation Duct, (From Exhaust to Burner	9973-032-001	2
*	Screw, 10B x 3/8"	9545-008-006	8

## Burner Housing Group Photos

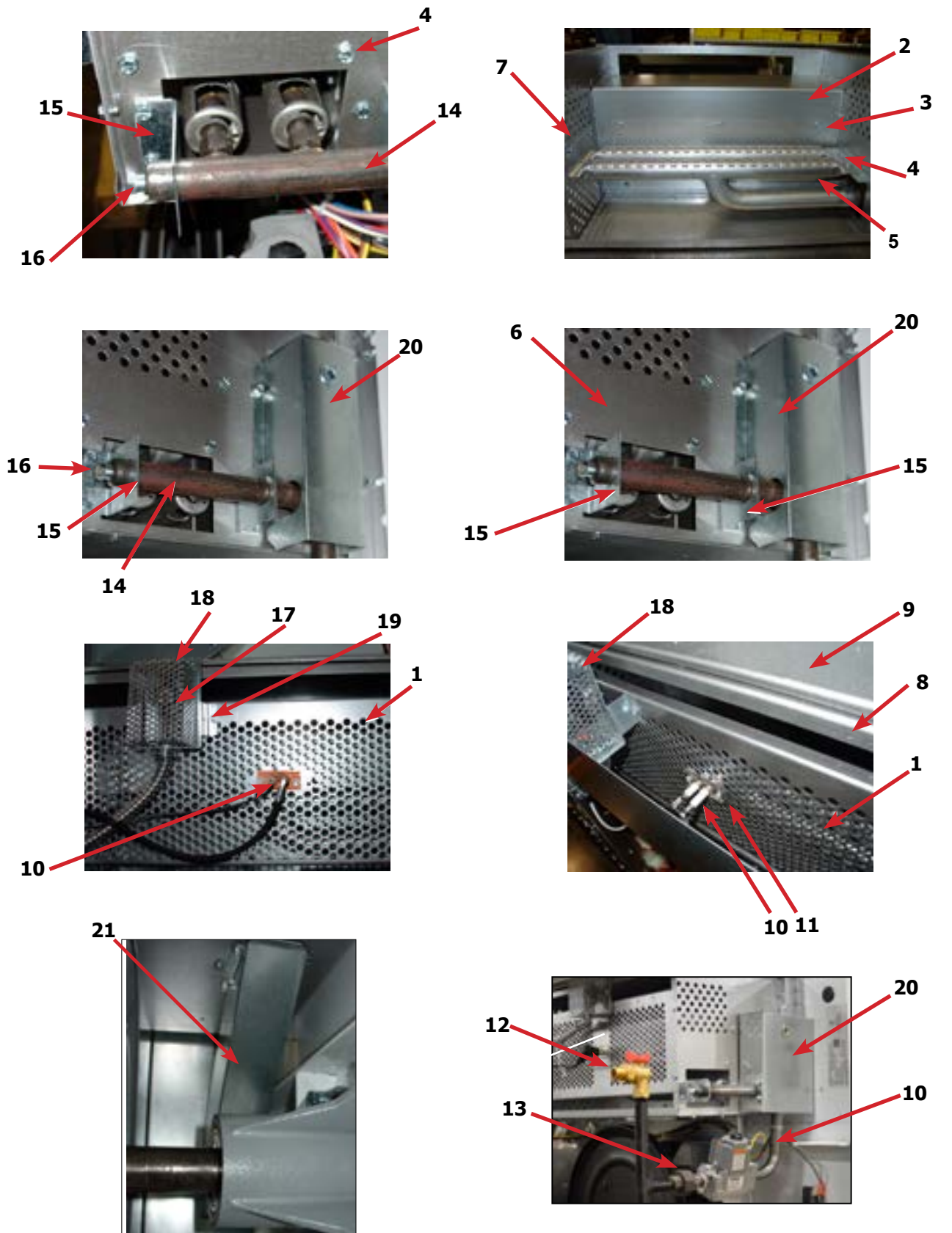

## Air Flow Switch Assembly

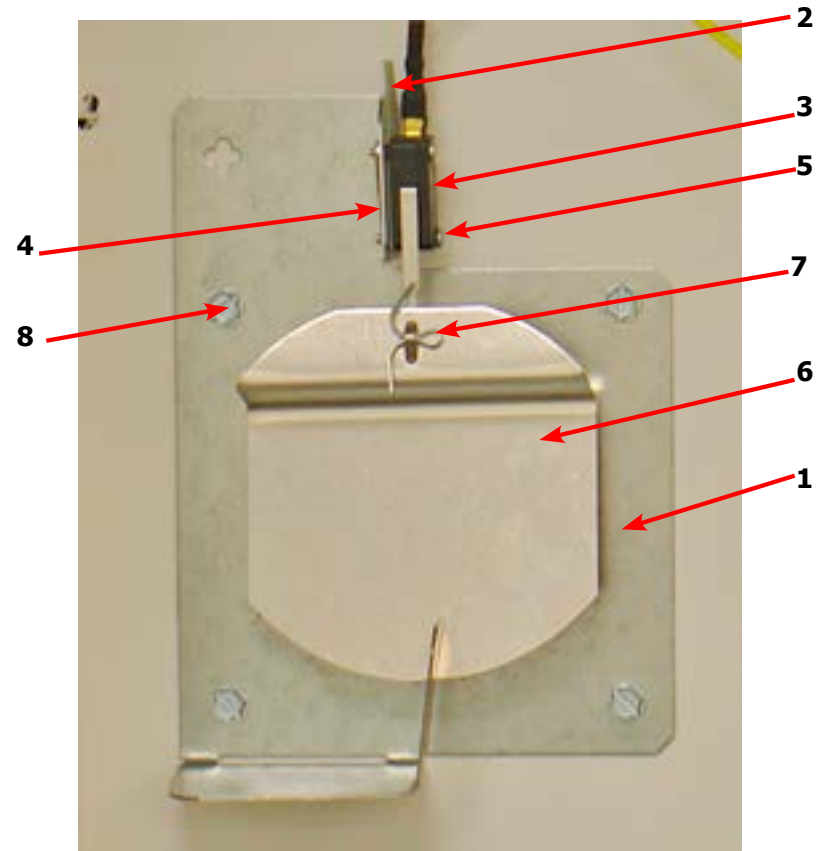

Key	Description	T-50X2-11 Reversing	QTY
*	Air Flow switch Assy	9801-098-001	2
1	Bracket-Airflow switch	9029-200-001	2
2	Shield-Switch	9550-169-003	2
3	Switch-Micro	9539-461-009	2
4	Nut-Twin, 4-40	8640-401-001	2
5	Screw-.625, 4-40	9545-020-001	2
6	Actuator-Air Flow Switch	9008-007-001	2
7	Pin-Cotter, .09375x.75	9451-169-002	2
8	Screw, 10Bx1/4	9545-008-001	8
*	Harness Assembly, Overtemp/Airflow	9627-861-001	1

## OPL Control Board

Key	Description	T-50X2-11 Reversing	QTY
1	Control Assembly (Black)	9857-187-004	1
2	PCB Control Board	9471-017-001	1
3	PCB Display Board	9471-018-001	1
4	Cable, Upper Control Long	9500-007-001	1
5	Cable, Lower Control Short	9500-007-002	1
6	Membrane Switch Assembly (Black)	9801-110-001	1
7	Fuse, 600ma / 250V	8636-024-001	2
*	Harness Main Control OPL Stack Dryer	9627-885-002	1
8	Control Tray	9826-006-001	1

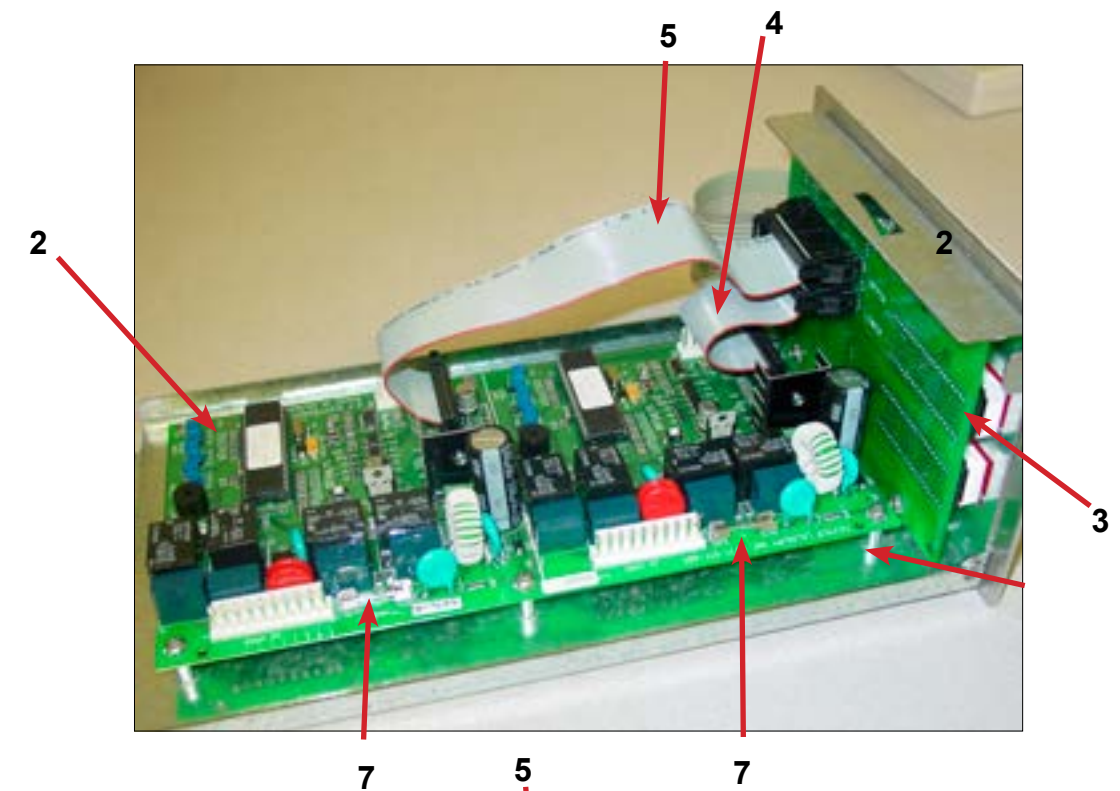

# Control Assembly Group

Key	Description	T-50X2-11 Reversing	QTY
*	Control, Rear	9857-223-002	1
*	Bracket, Terminal Block Power	9029-202-001	1
1	Strip, Terminal Marker	9558-029-006	1
2	Terminal-Block, Power, 4 Pole	9897-035-001	1
*	Screw, 10AB x 3/8"	9545-008-024	1
*	Harness Assembly-Power Main Fork, Upper	9627-859-005	1
*	Harness Assembly-Power Main Fork, Lower	9627-859-006	1
3	Wire Assembly-Ground, GRN/YEL, 7"	8220-137-002	1
*	Lock Washer, Ext tooth	8641-582-006	1
4	Screw, 10-32 x 1"	9545-008-027	1
5	Transformer, 120/208/240/60Hz.(In), 24/120VAC (Out)	8711-013-001	1
6	Screw, 10AB x 3/8"	9545-008-024	4
7	Fuse Holder Assembly	9200-001-002	2
*	Fuse, 1.5Amp/250V-Fast Acting	8636-018-001	2
8	Relay, Motor, 30Amp 24VAC	5192-299-002	2
*	Screw, Phillips, 8AB x 1/2"	9545-045-012	4
9	Terminal Block Power	9897-026-002	1
*	Screw, Phillips, 8AB x 1/2"	9545-045-012	2
10	Relay-Enable, 24VAC 50/60Hz	5192-285-004	2
*	Screw, Phillips, 8AB x 3/8"	9545-045-008	4
11	Relay-Reversing, 24VAC 50/60Hz	5192-285-004	2
*	Screw, Phillips, 8AB x 3/8"	9545-045-008	4
12	Drive-Inverter, 230VAC,	9375-032-011	2
*	Screw-Mounting, 10B x 1/2"	9545-008-026	8
13	Key-Pad, Display, Delta E-Drive	9150-044-001	2
14	Resister-Dynamic Breaking, 2000Ohm	9483-004-002	2
*	Screw, 10AB x 3/8"	9545-008-024	4
*	Wire Assembly, Violet, 8"	8220-118-003	4
*	Screw, #6-32 x 5/16"	9545-044-006	4
*	Nut, Hexkeys, #6-32	8640-411-003	4
15	Terminal Block, Power	9897-026-003	2
*	Screw, Phillips, 8AB x 1/2"	9545-045-012	4
*	Harness-Assembly, Low Voltage, Upper	9627-867-007	1
*	Harness-Assembly, Low Voltage, Lower	9627-867-008	1
16	Ignition Module	9857-182-001	2
*	Screw, 10AB x 3/4"	9545-008-018	4
17	Wire Assembly, High Voltage	9631-403-009	2
*	Harness Extension (Internal)	9627-887-002	1
*	Harness Extension (External)	9627-885-002	1
*	Harness, Overtemp & Air flow switch	9627-861-001	2
*	Door-Control Box	9108-139-001	1
*	Screw, 10AB x 3/8"	9545-008-024	3

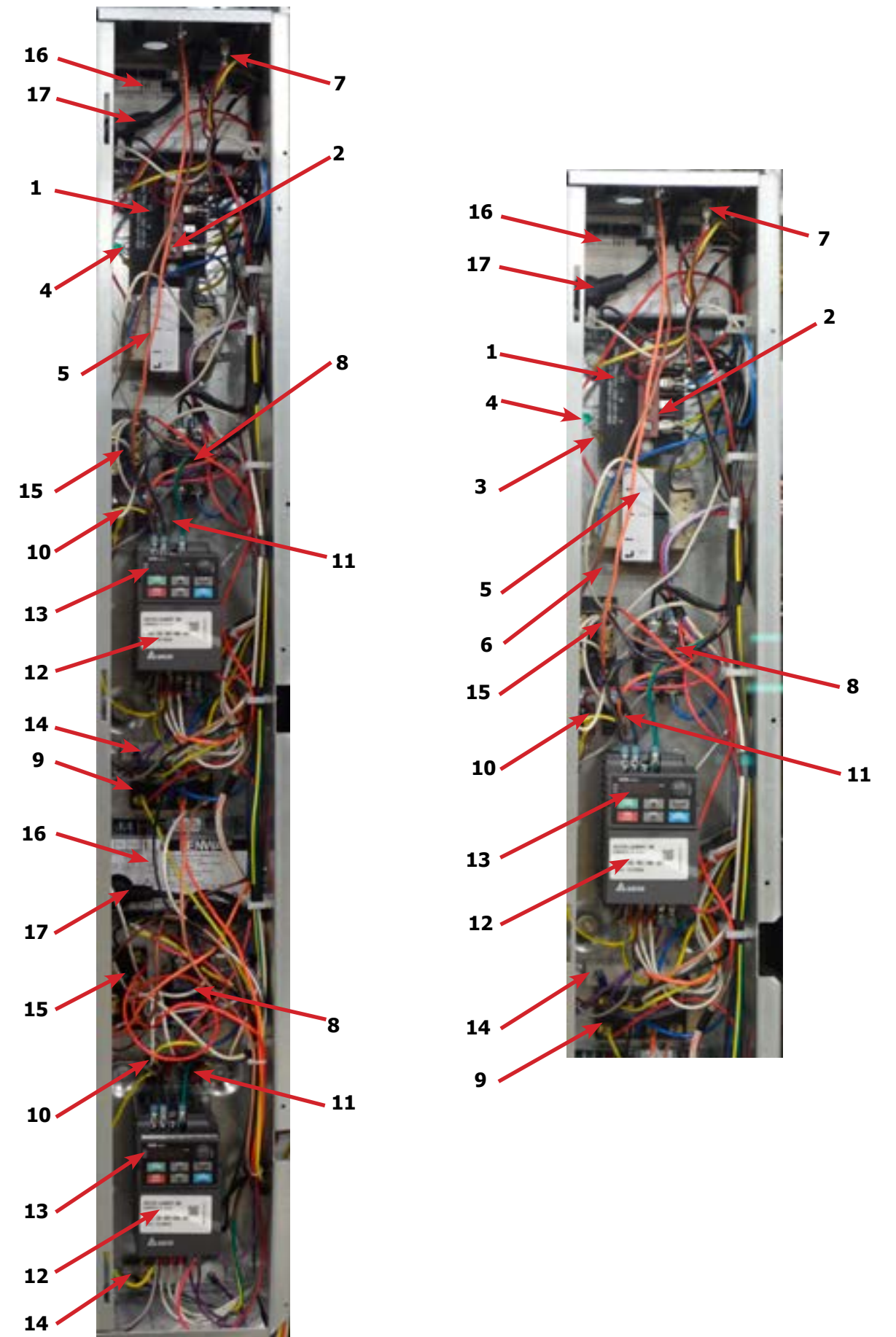

# Sensor Assembly, Thermistor

Key	Description	T-50X2-11 Reversing	
*	Bracket for Heat Sensor Mounting (Under Basket) w/ sensor	9501-008-002	2
1	Bracket Assembly Thermistor	9985-188-001	2
2	Gasket spacer	9206-176-000	2
3	Grommet	9209-037-002	2
4	Screw, 8B x 14	9545-045-005	2
5	Sensor-Heat, Thermistor- 10K Ohm	9501-004-004	2
*	Screw-Mounting, 10AB x 3/8	9545-008-024	2

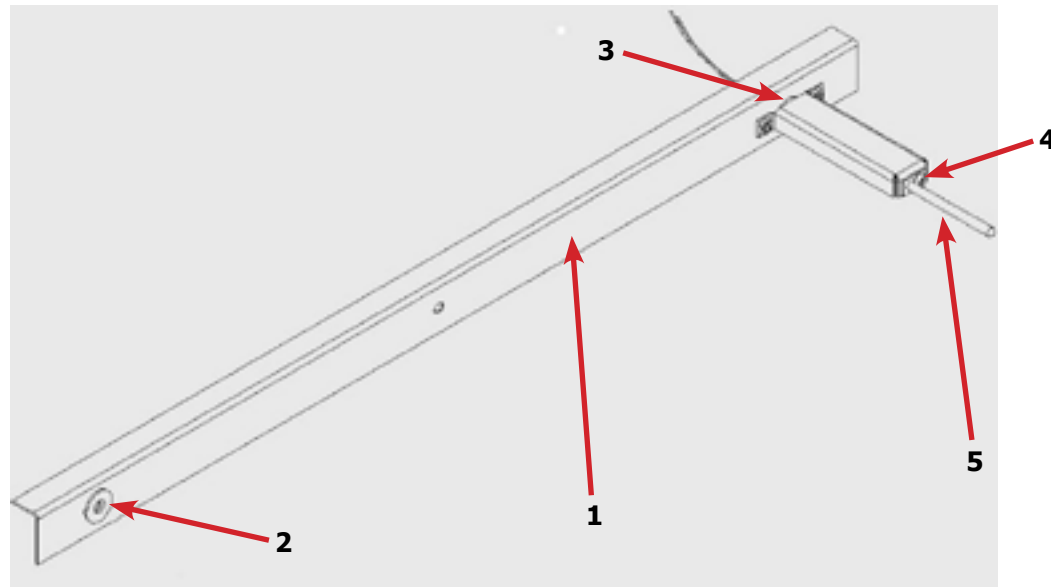

# Wiring Schematic for DN50x2 Reversing

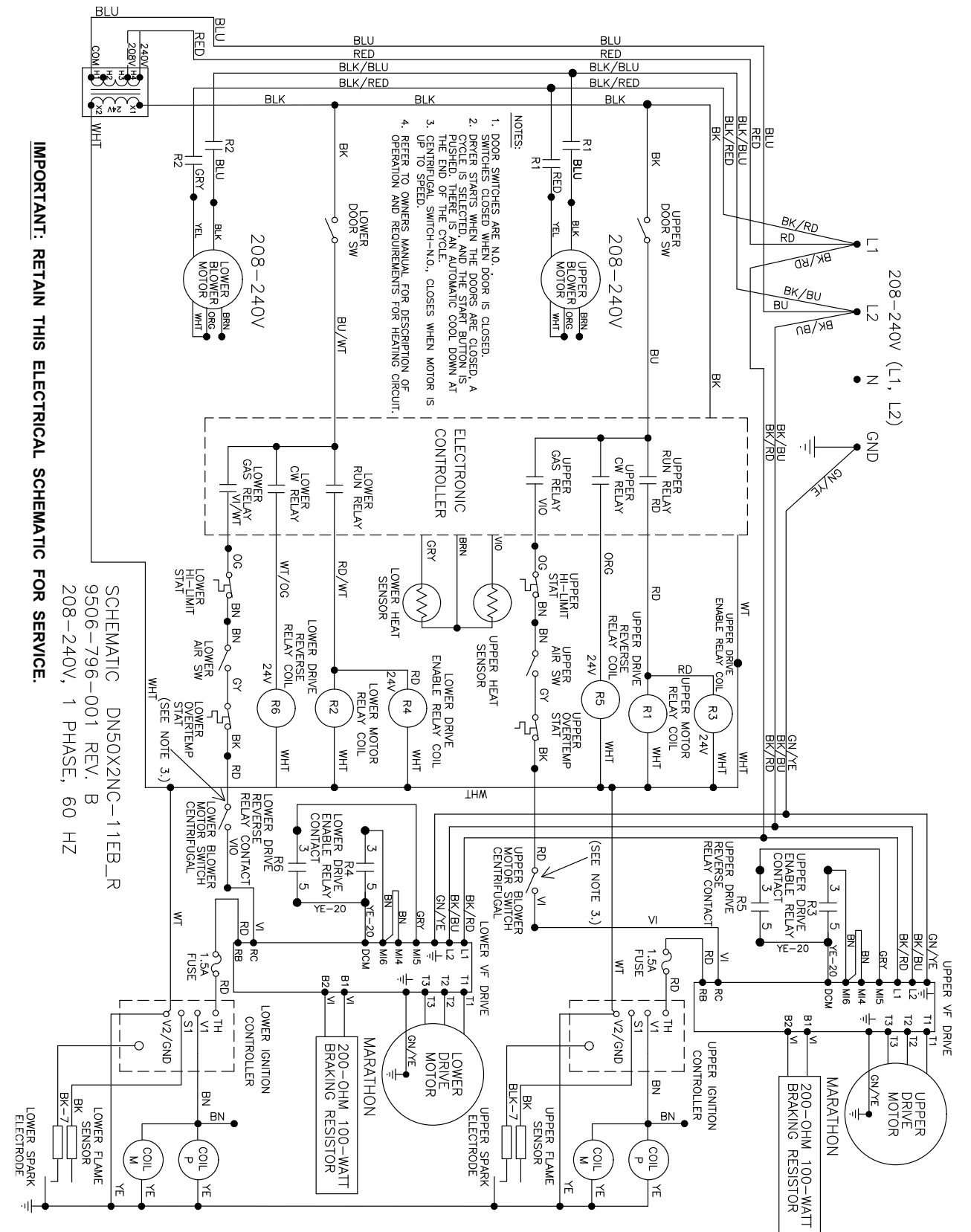



# Section 8:

## 50Hz. Parts

### Data 50# Stack

## Rear View Photos

Key	Description	T-50X2-39 Reversing	QTY
*	Spacer, Tumbler pulley	9538-047-002	2
1	Pulley, Driven	9908-047-002	2
*	Tolerance Ring	9487-234-005	2
2	Washer-Flat, 1/2"	8641-581-026	2
3	Lock Washer, 1/2"	8641-582-016	2
4	Bolt, 1/2"-13 x 1" 1/4"	9545-017-009	2
5	Belt, Drive	9040-076-003	2
6	Air Flow Switch, Assembly	9801-098-002	2
7	Motor-Drive, 2Hp.	9376-319-001	2
8	Pulley-Motor, Drive	9453-169-012	2
*	Screw-Set, 5/16"-18 x 1/2"	9545-028-013	4
9	Rod-Motor Mounting	9497-222-008	2
*	Bushing, Motor Support	9053-074-002	4
10	Collar-Shaft, w/Set Screw	9076-052-002	2
11	Spring, Belt Tension	9534-319-002	2
12	Chain, Spring Tension, 15 1/2" (27 Links)	9099-012-008	2
13	Hook, "S" Hook	9248-022-002	2
14	Drive-VF, Inverter, 2Hp 230VAC	9375-032-011	2
*	Assembly, Impeller-Blower Motor (15-17)	9919-019-002	2
15	Plate Assembly, Impeller-Blower Motor	9982-388-002	2
*	Nut, 5/16"-18	8640-400-003	8
*	Impeller, w/Set Screws	9278-043-001	2
16	Motor, Blower, 50HZ.	9376-311-004	2
17	Bolt-Motor Mounting, 5/16, 18 x 5/8"	9545-014-004	8
18	Nut-1/4" x 20, Mounting Plate, Impeller Motor Assy.	8640-414-007	14

## Rear View Photos

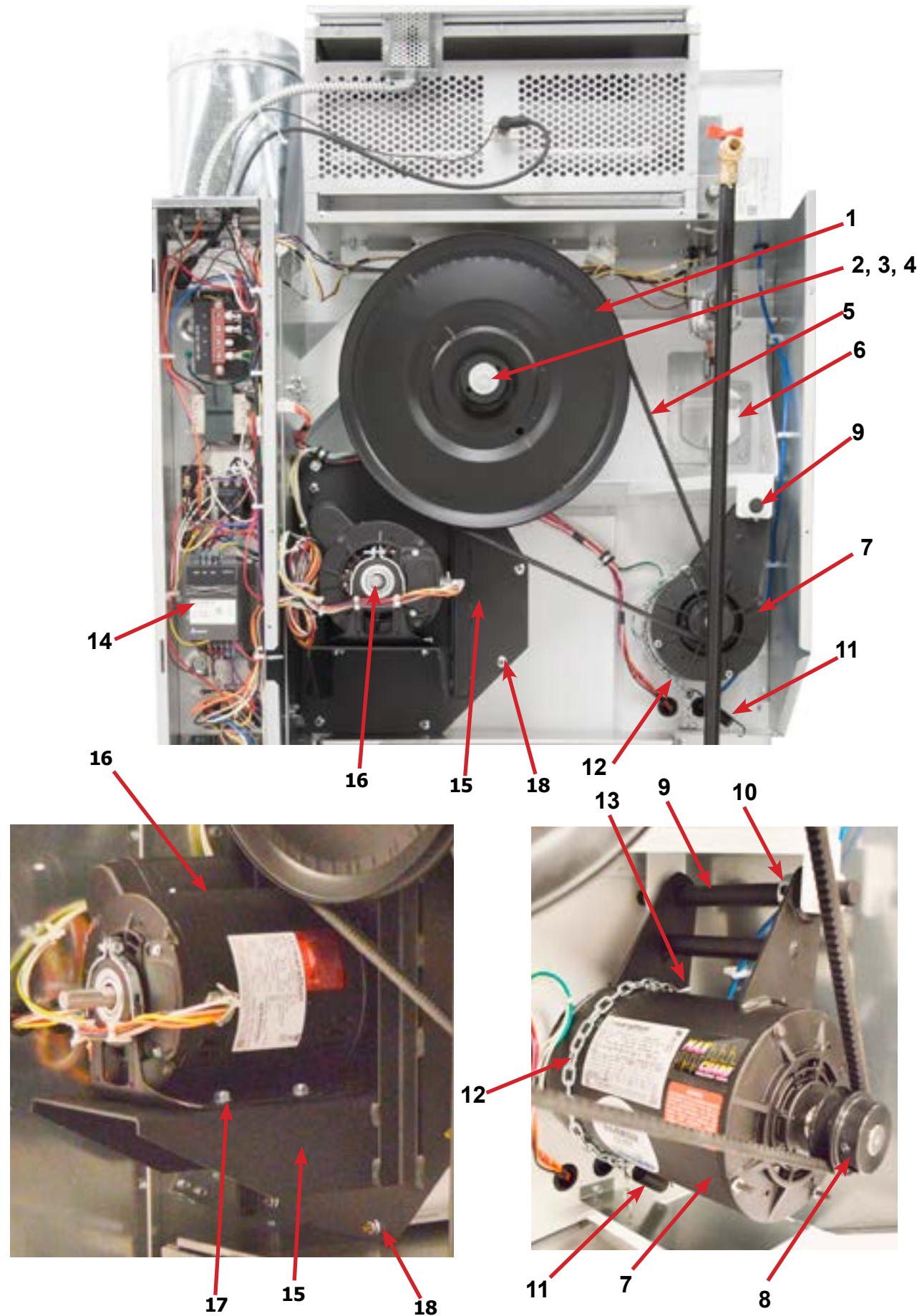

## Electrical Components



Key	Description	T-50X2-39 Reversing	QTY
1	Transformer, 200/230-24 VAC, 50/60HZ	8711-004-004	1
*	Strip-Marker, Terminal	9558-029-004	1

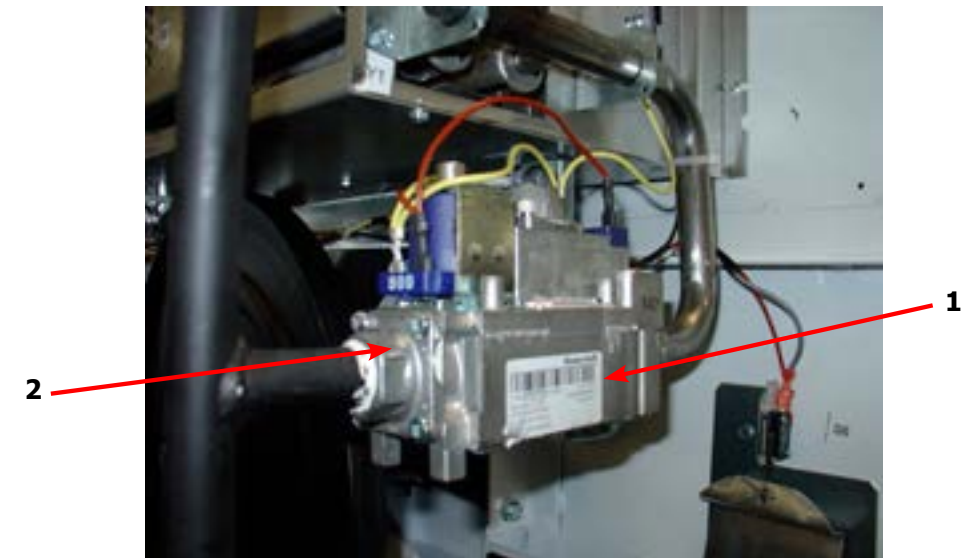

Key	Description	T-50X2-39Reversing	QTY
1	Control Assembly, Gas Valve	9857-132-004	2
2	Kit-Honeywell VR86, Valve Flange assy	9732-162-001	4
*	Orifice, Main Burner, #30	9425-069-002	4

# Air Flow Switch Assembly

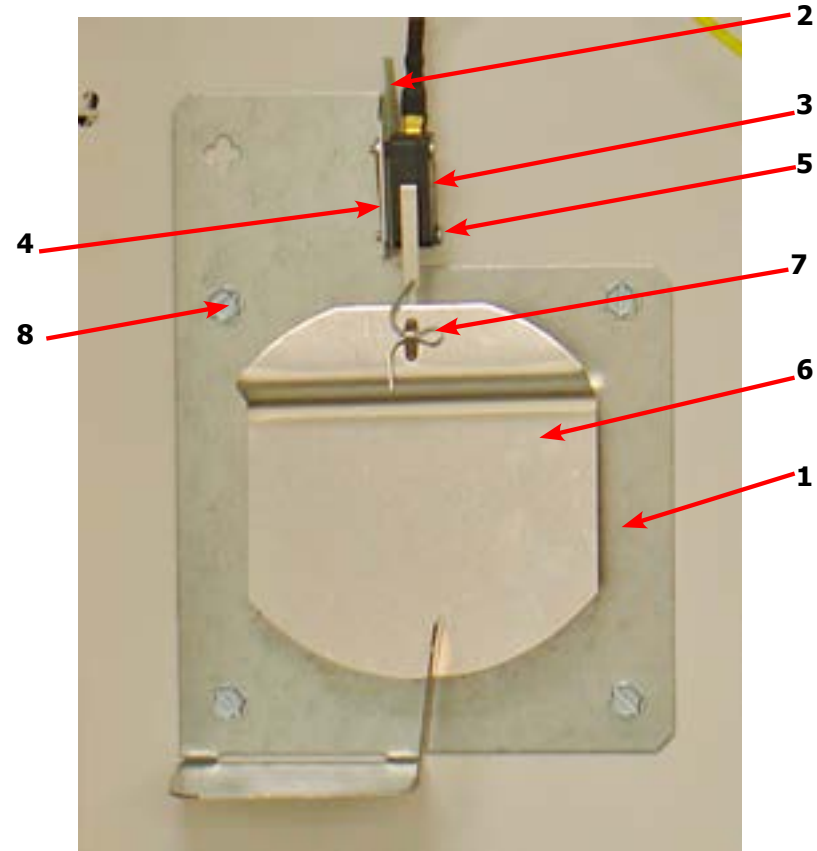

Key	Description	T-50X2-39 Reversing	QTY
*	Air Flow switch Assy	9801-098-002	2
1	Bracket-Airflow switch	9029-200-002	2
2	Shield-Switch	9550-169-003	2
3	Switch-Micro	9539-461-009	2
4	Nut-Twin, 4-40	8640-401-001	2
5	Screw-.625, 4-40	9545-020-001	2
6	Actuator-Air Flow Switch	9008-007-001	2
7	Pin-Cotter, .09375x.75	9451-169-002	2
8	Screw, 10Bx1/4	9545-008-001	8
*	Harness Assembly, Overtemp/Airflow	9627-861-001	1

# Wiring Schematic for DN50x2 Reversing 50Hz.

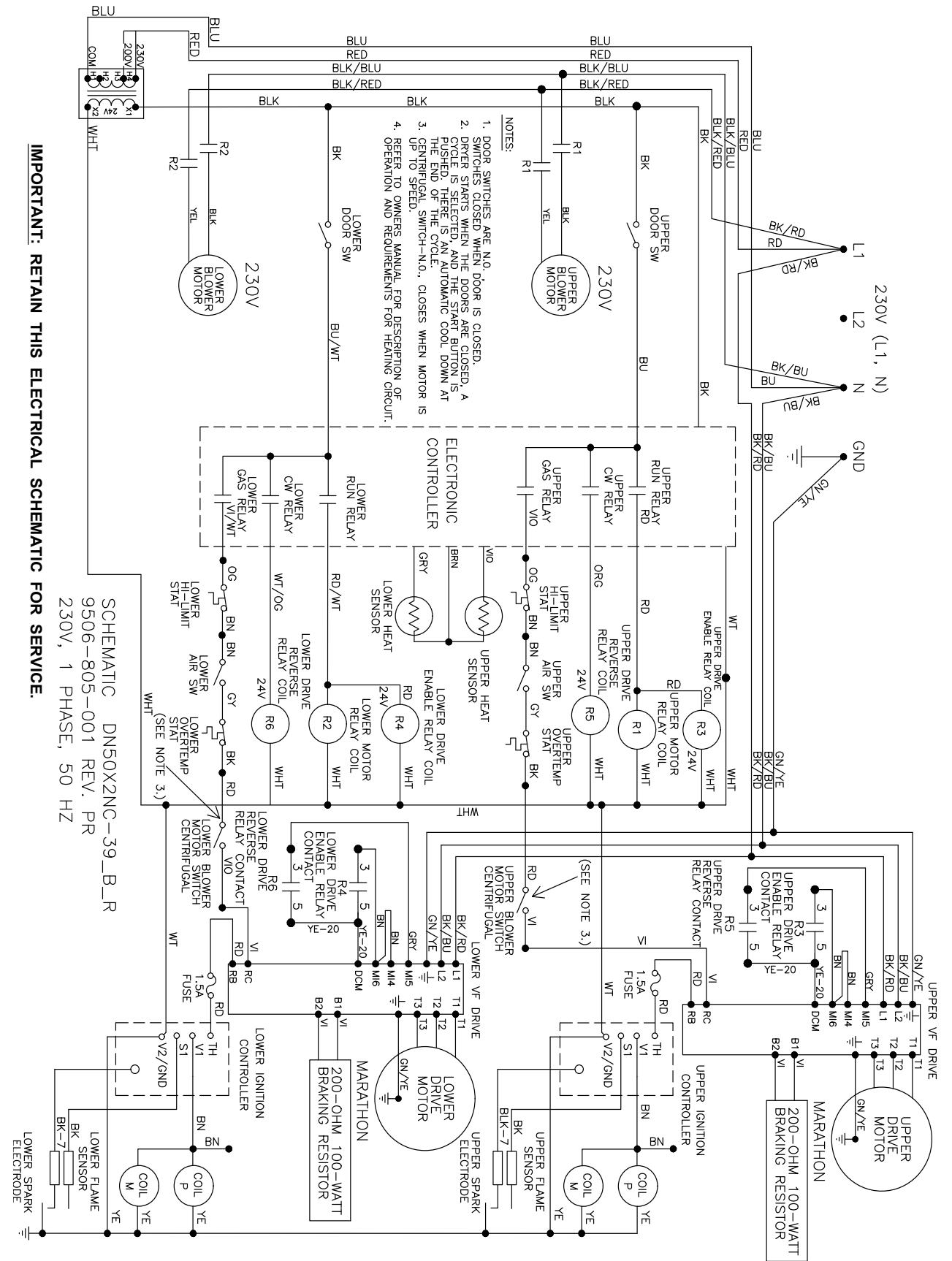



# Wiring Diagram for DN50x2 Reversing 50Hz.

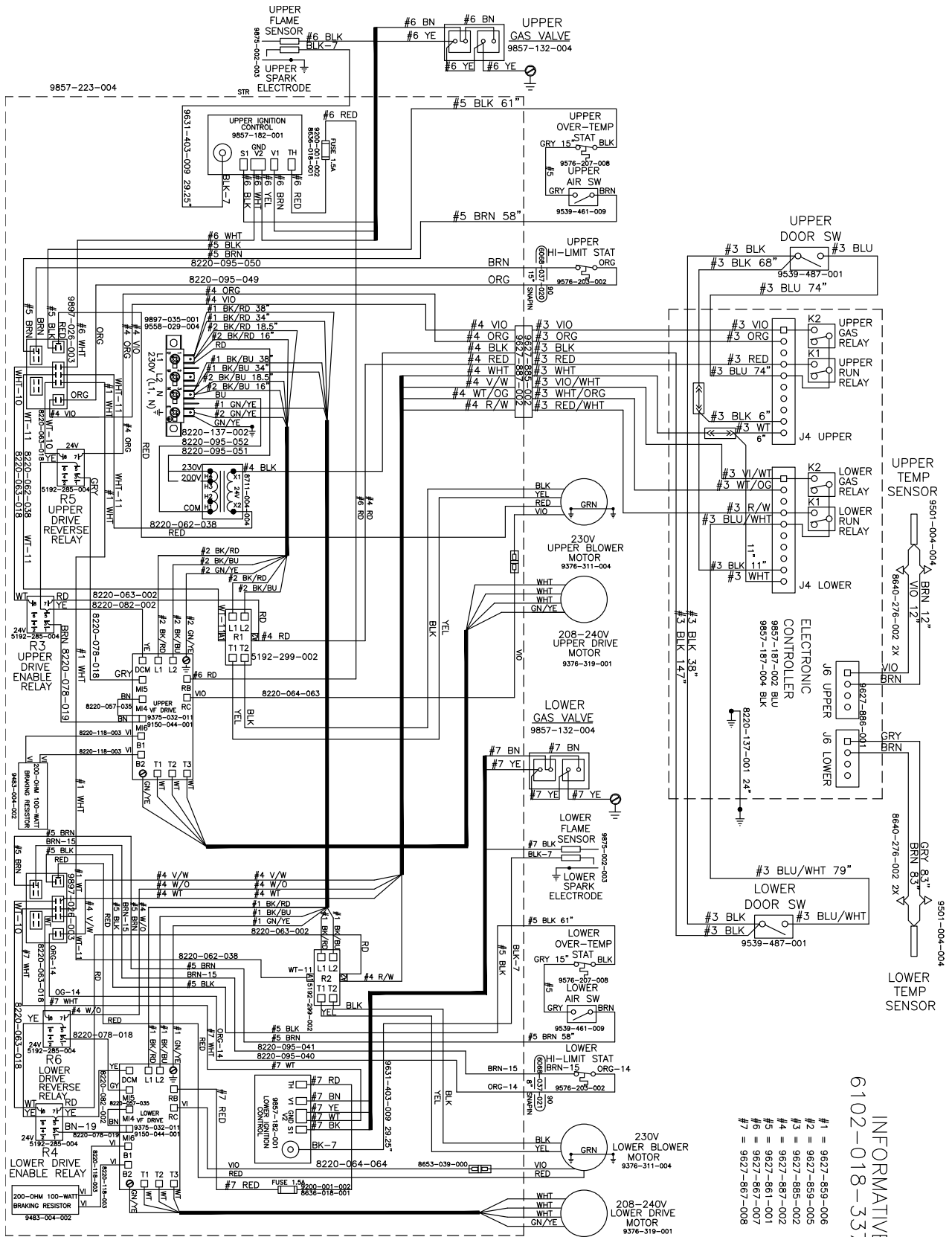

- INFORMATIVE
- 6102-018-337PR
- #1 = 9627-859-006
  - #2 = 9627-859-005
  - #3 = 9627-885-002
  - #4 = 9627-887-002
  - #5 = 9627-861-001
  - #6 = 9627-867-007
  - #7 = 9627-867-008

9506-805-001PR WIRING DIAGRAM DN50X2NC-39\_B\_R

**IMPORTANT: RETAIN THIS ELECTRICAL DIAGRAM FOR SERVICE.**