



***DEXTER***<sup>®</sup>  
***LAUNDRY***

**USE THE BLUE TABS LOCATED ON THE  
RIGHT AND LEFT SIDES OF THE FOLLOWING  
DOCUMENT TO ADVANCE TO EACH SECTION.**

## Kits, Assemblies, & Common Parts

Description	T-50
LP to Natural Conversion Kit for White Rodgers	9732-142-004
Kit, Optional Replacement for Round Switch 9539-492-001	9732-351-001
Temperature Probe	9501-004-002
Control	9732-249-001
Ignition Control Box	9857-182-001
Electrode Assembly, Ignition	9875-002-003
Thermostat, Hi-Limit	9576-203-002
Thermostat, Overtemp	9576-207-008
Motor Run Relay	5192-299-002
Transformer	8711-007-002
Lint Screen	9822-026-001
Air Flow Switch Assembly	9801-098-002
Door Switch (Square)	9539-501-001
Door Switch (Round)	9539-492-001
Drive Belt	9040-076-004
Tension Arm Complete	9861-024-004
Spider/Trunnion	9568-017-001
Door Handle	9244-082-001



DN0050NC-11EB2R

## Section 5: Dryer Parts Data

## Dryer Cabinet Group

Key	Description	T-50	QTY
1	Loading Door Complete SS/Brushed SS/Blk	9960-305-001	1
1	Loading Door Complete Wht/Brushed SS/Blk	9960-305-003	1
2	Door Assy, Loading (Ring only) Brushed SS	9960-284-002	1
2	Door Assy, Loading (Ring only) Blk (after serial D1.22290.005)	9960-320-004	1
3	Plate Assy, Hinge (SS)	9982-368-001	1
3	Plate Assy, Hinge (Wht)	9982-368-003	1
*	Cover-Hinge Back, Black	9074-340-002	1
*	Screw-10Bx3/8, Black	9545-008-010	2
*	Screw Hinge to Door	9545-012-015	4
*	Nut, Hinge to Door	8640-413-002	4
4	Glass, Door	9212-002-004	1
5	Gasket, Door Glass (Black)	9206-413-002	1
*	Support Door Glass	9548-117-000	2
6	Gasket, Door Outer Rim (Black)	9206-420-005	1
7	Handle, Loading Door	9244-082-001	1
*	Screw, Handle	9545-018-017	2
8	Stud Door Catch	9531-033-003	1
9	Nut-Hex, #10-32	8640-413-001	1
10	Nut, Acorn	8640-413-003	1
*	Catch, Loading Door	9086-015-002	2
*	Rivit	8638-190-009	4
11	Strap, Hinge (Black)	9966-014-002	1
*	Plate Assy-Backup, Hinge	9982-356-001	2
12	Screw-Phillips, 10-32x1/2 Chrome	9545-012-003	8
*	Screw-Phillips-Counter sink, 10-32x1/2 Chrome	9545-012-028	4
13	Screw-Special, Hinge to Door	9545-052-001	1
*	Nut-Allen, 1/4-20	8640-439-001	1
14	Washer-Fiber/Plastic	8641-436-003	1
15	Front Panel Assy (SS) Round Switch	9454-866-001	1
15	Front Panel Assy (SS) Square Switch	9444-004-001	1
15	Front Panel Assy (Wht) Round Switch	9454-866-003	1
15	Front Panel Assy (Wht) Square Switch	9444-004-003	1
16	Screw-Phillips, 10Bx1 3/4	9545-008-014	4
17	Washer-Finish	8641-585-001	4
*	Nut-Spring (Before Serial D1.21162.038)	8640-399-001	4
*	Nut-Expansion (After Serial D1.21162.038)	8640-442-001	4
*	Insulation-Front Panel, Top Half	9277-057-001	1
*	Insulation-Front Panel, Bottom Half	9277-057-002	1
18	Label-Warning	8502-753-001	1
19	Plug-Front Panel	9456-050-001	1
*	Switch-Door (Round)	9539-492-001	1
*	Switch-Door (Square)	9539-501-001	
*	Wire-Assy, Blk	8220-063-026	1
*	Wire-Assy-Blu	8220-063-009	1
*	Cabinet Touch Up Paint (White)	9472-001-013	1

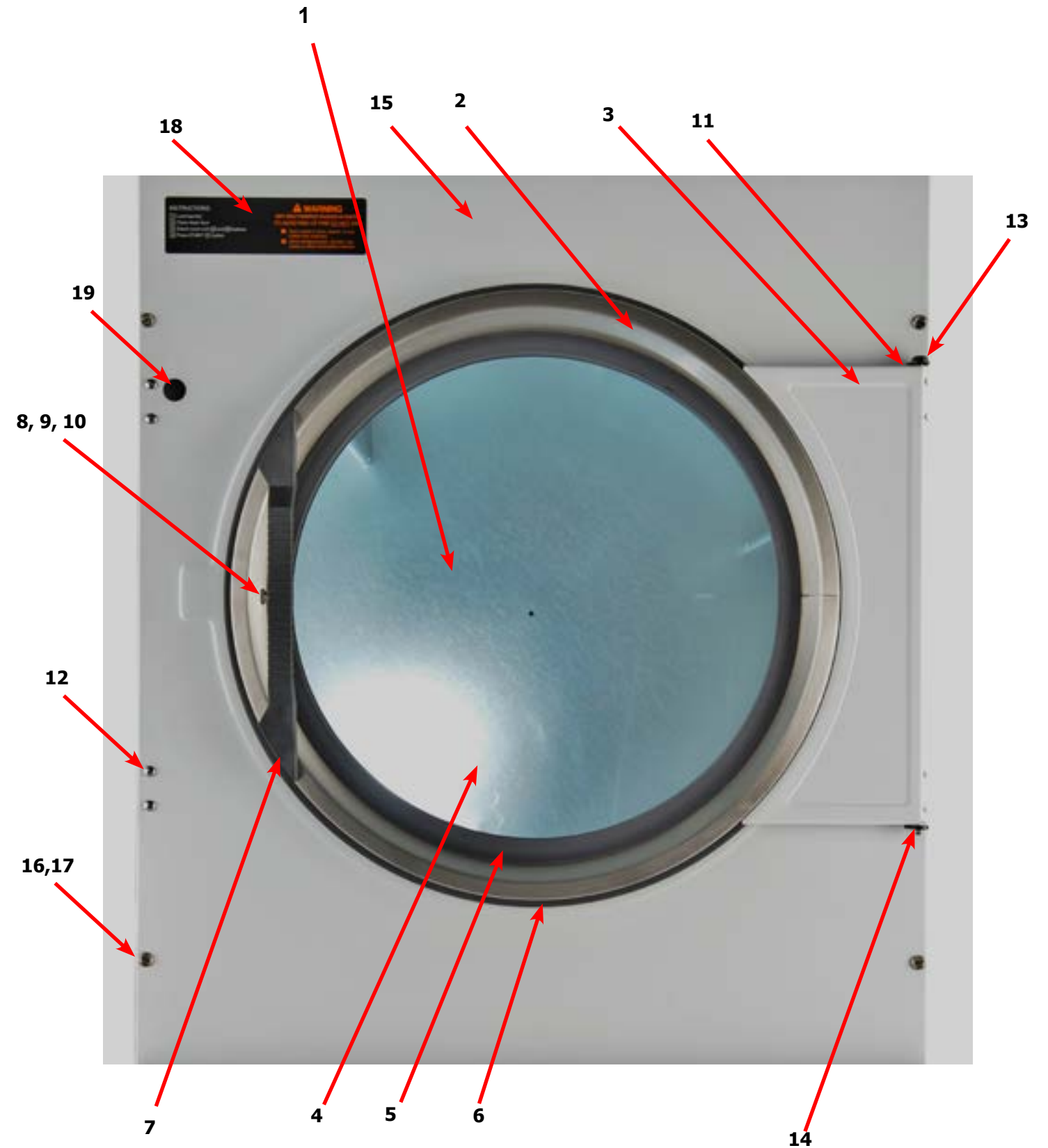

## Dryer Cabinet Group Continued

Key	Description	T-50	QTY
1	Nameplate - Dexter Dryer Black	9412-216-001	1
2	Door Assy-Upper, OPL (SS)	9960-290-001	1
2	Door Assy-Upper, OPL (Wht)	9960-290-003	1
*	Bracket-Hinge	9029-224-001	2
*	Rivit- 3/16, Hinge to Door	9491-009-001	2
*	Rivit- 3/16, Hinge to Cabinet	9491-009-001	AR
*	Screw, 10-32 x3/4	9545-012-006	4
*	Nut #10-32UNF, 2B	8640-413-002	4
3	Trim-Upper Service Door, Black	9578-094-002	1
4	Screw-Phillips, 10Bx3/8, Black	9545-008-010	4
5	Screw-Phillips, 10Bx1 3/4	9545-008-014	2
6	Washer-Finish	8641-585-001	2
*	Nut-Spring	8640-399-001	2
7	Membrane Switch	9801-103-001	1
8	Kit-30/50/80 OPL, PCB-Controler	9732-249-001	1
*	Spacer-#6 x 1/2	9538-157-015	4
9	Nut- #6-32	8640-411-003	4
10	Wire Assy-GRN/YEL, 24"	8220-137-001	1
11	Fuse, .600MA/250V	8636-024-001	1
12	Support-Upper Service Door	9548-288-002	1
13	Clamp-Tube	9079-121-002	2
14	Nut, #6-32	8640-411-003	2
15	Clamp-Cable, 1/2"	8654-125-006	1
16	Nut, #6-32	8640-411-003	1
17	Insulation	9277-041-016	1
*	Harness-Control	9627-770-003	1
*	Harness-Temp Probe	9627-679-002	1

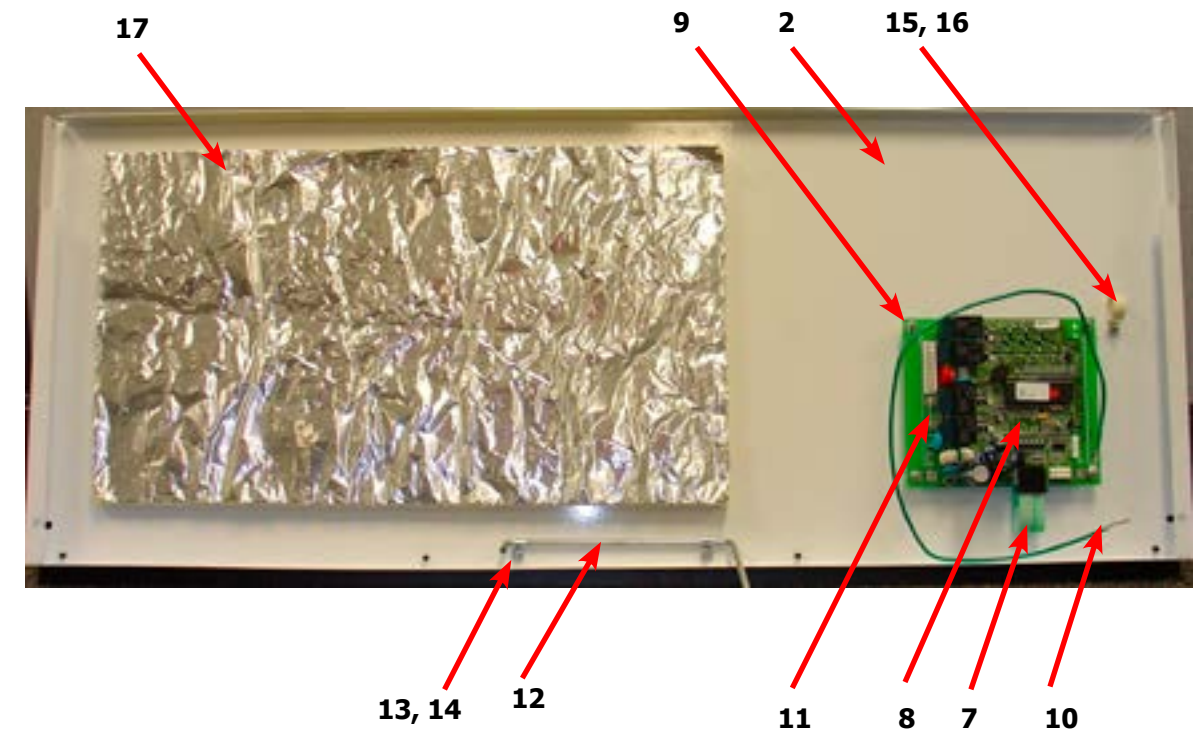



## Dryer Cabinet Group Continued

Key	Description	T50	QTY
1	Door-Lower Service, OPL, SS	9108-123-001	1
1	Door-Lower Service, OPL, Wht	9108-123-003	1
2	Handle-Door, Lower Service, Black	9244-087-002	1
3	Screw-Phillips, 10Bx3/8, Black	9545-008-010	5
4	Handle-Door, Lower Service OPL	9244-084-002	1
5	Trim-Lower Kick, Black	9578-095-002	1
6	Screw-Phillips, 10Bx3/8, Black	9545-008-010	4
7	Screen Assy, Lint	9822-026-001	1
8	Switch-Door (Round)	9539-492-001	1
*	Switch-Door (Square)	9539-501-001	1
*	Kit, Optional Replacement for Round Switch 9539-492-001	9732-351-001	1
9	Hinge-Door, Lower	9243-082-001	1
10	Screw-5/16, 10ABx3/8	9545-008-024	5
11	Bracket-Door Switch	9029-226-001	1
*	Rivit, 1/8 Low Profile	9491-009-004	2
12	Bracket-Chain	9029-223-001	2
*	Rivit, 1/8 Low Profile	9491-009-004	6
13	Hook, "S" Type	9248-022-002	4
14	Chain-Lower Service Door, 9 1/2" or 18 Links	9099-012-006	2
*	Leg, Leveling 1/2"	8544-006-001	4
*	Leveling Leg Wrench	8545-061-002	1

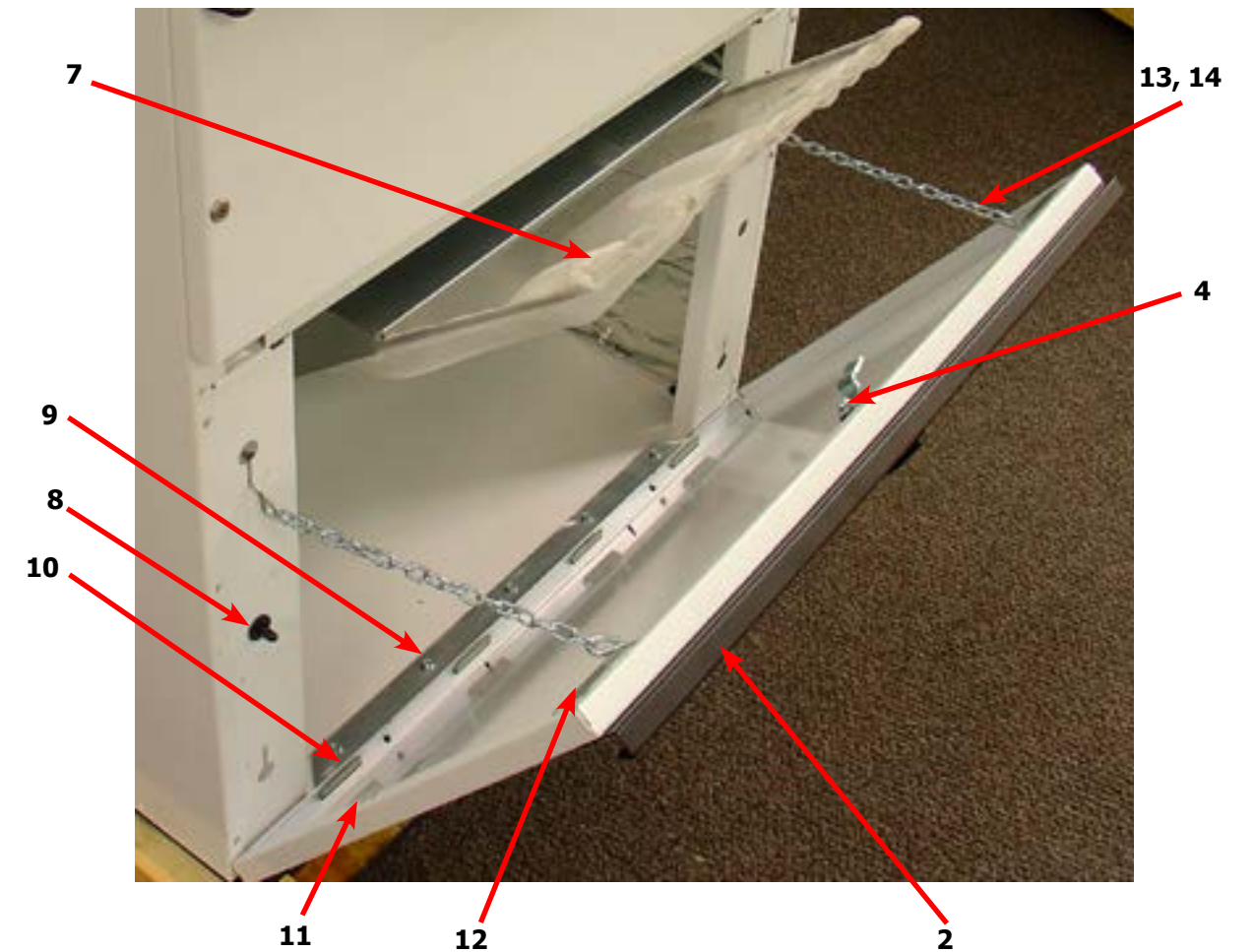
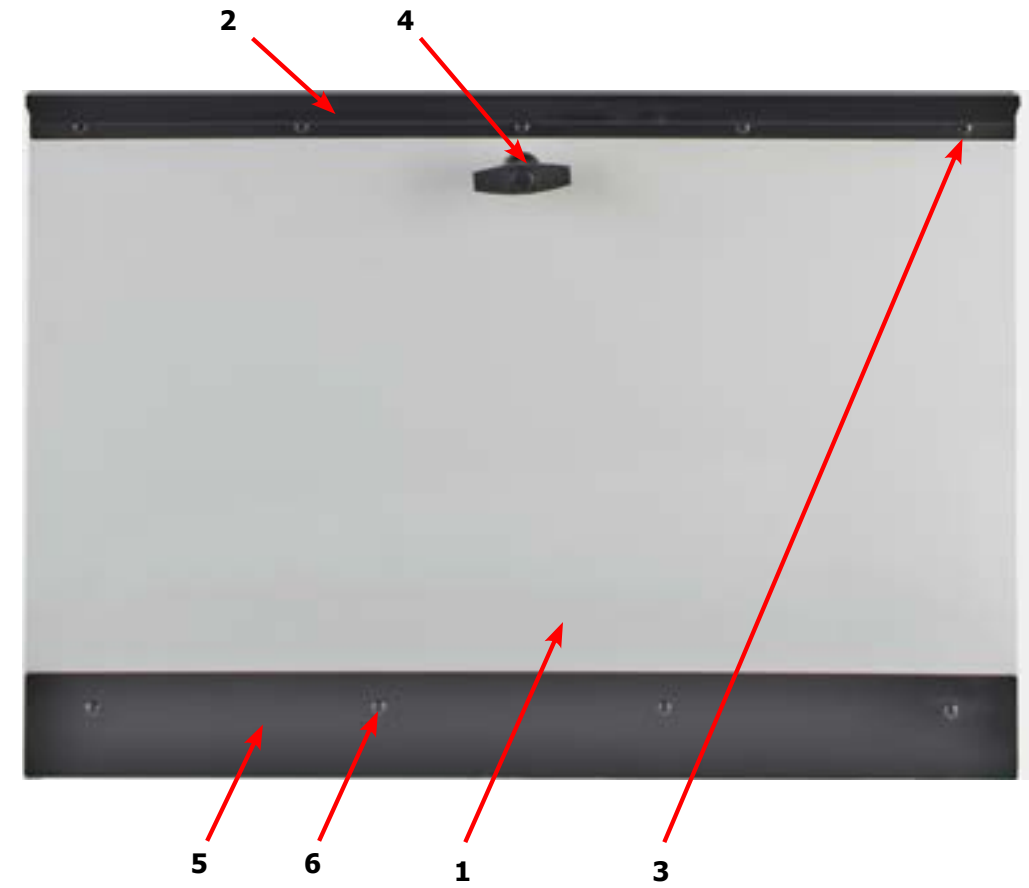

## Dryer Cabinet Group Continued

Key	Description	T-50	QTY
1	Insulation, Upper service Door	9277-041-016	1
2	Insulation, RH Burnner	9277-041-023	1
3	Insulation Tumbler Area, above Baffel	9277-041-023	2
3	Insulation Tumbler Area, above Baffel	9277-041-023	2
4	Insulation Tumbler Area, below baffel	9277-051-003	2
4	Insulation Tumbler Area, below baffel	9277-051-003	2
5	Insulation Lint Compartment	9277-041-024	2
*	Screen Assy, Lint	9822-026-001	1
6	Switch-Door (Round)	9539-492-001	1
*	Switch-Door (Square)	9539-501-001	1
7	Hinge-Door, Lower	9243-082-001	1
8	Screw-5/16, 10ABx3/8	9545-008-024	5
9	Lint Hood-Back	9240-041-001	1
10	Nut Wizlock, 8-32	8640-412-004	6
11	Lint hood, LH	9240-043-001	1
12	Lint hood, RH	9240-043-002	1
13	Lint hood, Top	9240-042-001	1
14	Screw, 5/16- 10ABx3/8	9545-008-024	16
15	Impeller, w/set screws	9278-037-003	1
16	Harness -Temp Probe	9627-679-002	1
17	Wire Nut, #71B	8640-276-005	2
18	Temp Probe	9501-004-002	1
19	Screw-Phillips, 8Bx1/4	9545-045-005	1

### 50Lb Temp Probe

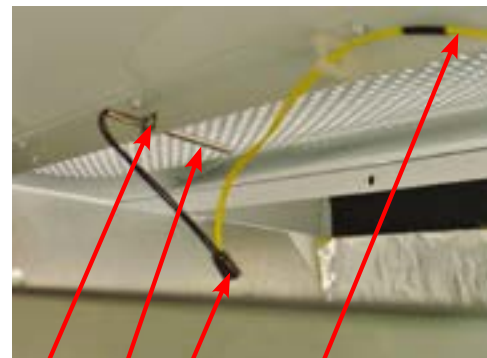

19 18 17 16

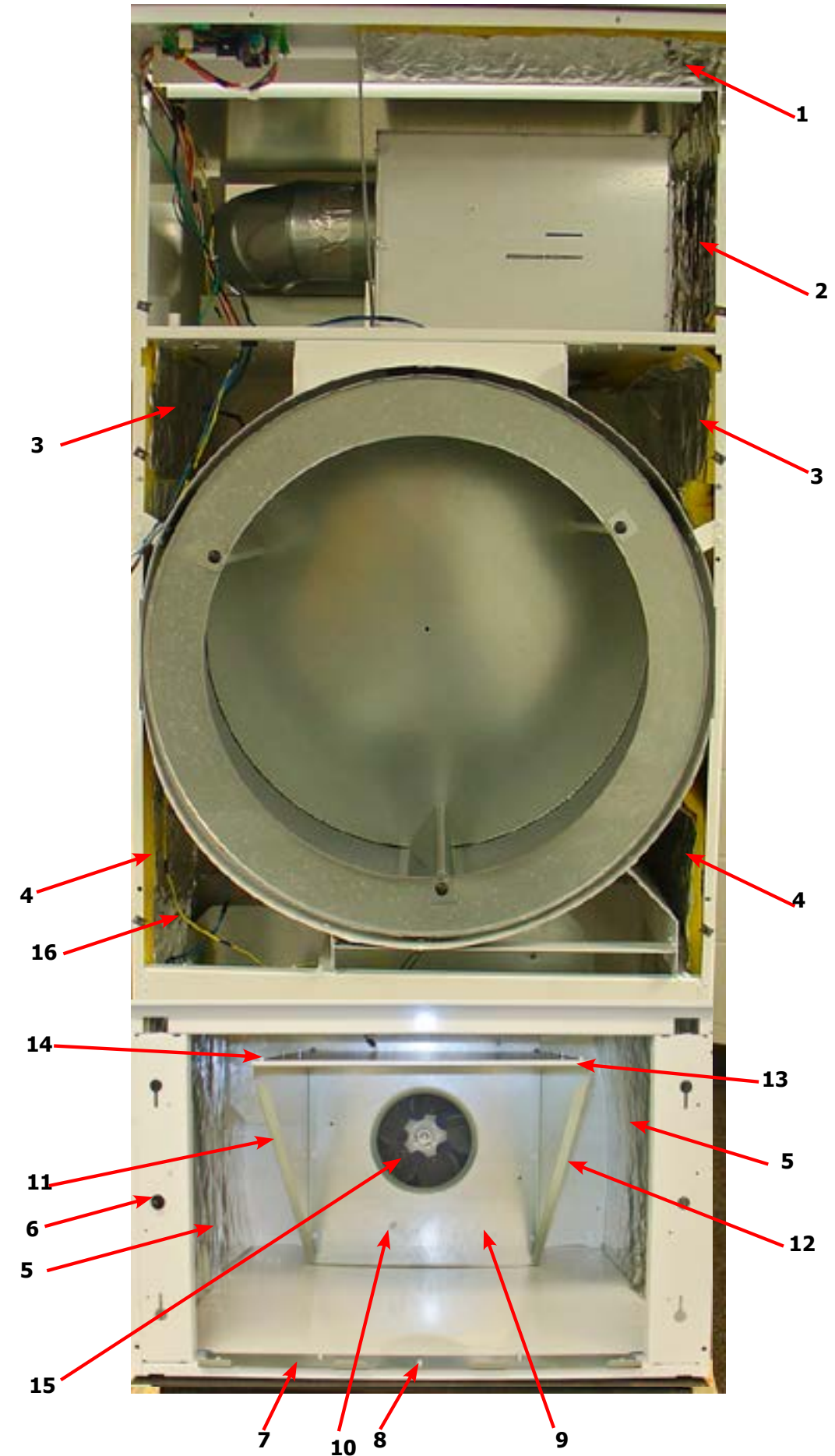

## Dryer Modular Cabinet Group 50lb. (After Serial D1.23145.014)

Key	Description	T80	QTY
1	Cabinet Base Assembly	9945-165-001	1
*	Lower Back Panel Assembly	9989-726-002	1
2	Lower Cabinet RH Side Panel	9444-104-003	1
3	Lower Cabinet LH Side Panel	9444-104-004	1
4	Lower Cabinet Front Channel	9081-222-001	1
*	Upper Back Panel Assembly	9989-727-002	1
5	RH Middle Side Panel Assembly	9989-728-003	1
6	LH Middle Side Panel Assembly	9989-728-004	1
7	Cabinet Top Assembly	9961-164-001	1
8	RH Baffle	9049-130-001	1
9	LH Baffle	9049-130-002	1
*	Baffle Stiffener Angle	9003-386-001	2
10	RH Upper Side Panel	9444-108-003	1
11	LH Upper Side Panel	9444-108-004	1
12	Upper Cross Brace	9046-105-001	1
*	10abx3/8 Screw	9545-008-024	21
*	Large Head Pop Rivet	8638-190-028	4
*	3/16 Blind Rivet	9491-009-001	122
*	Wht 3/16 Blind Rivet	9491-009-005	54

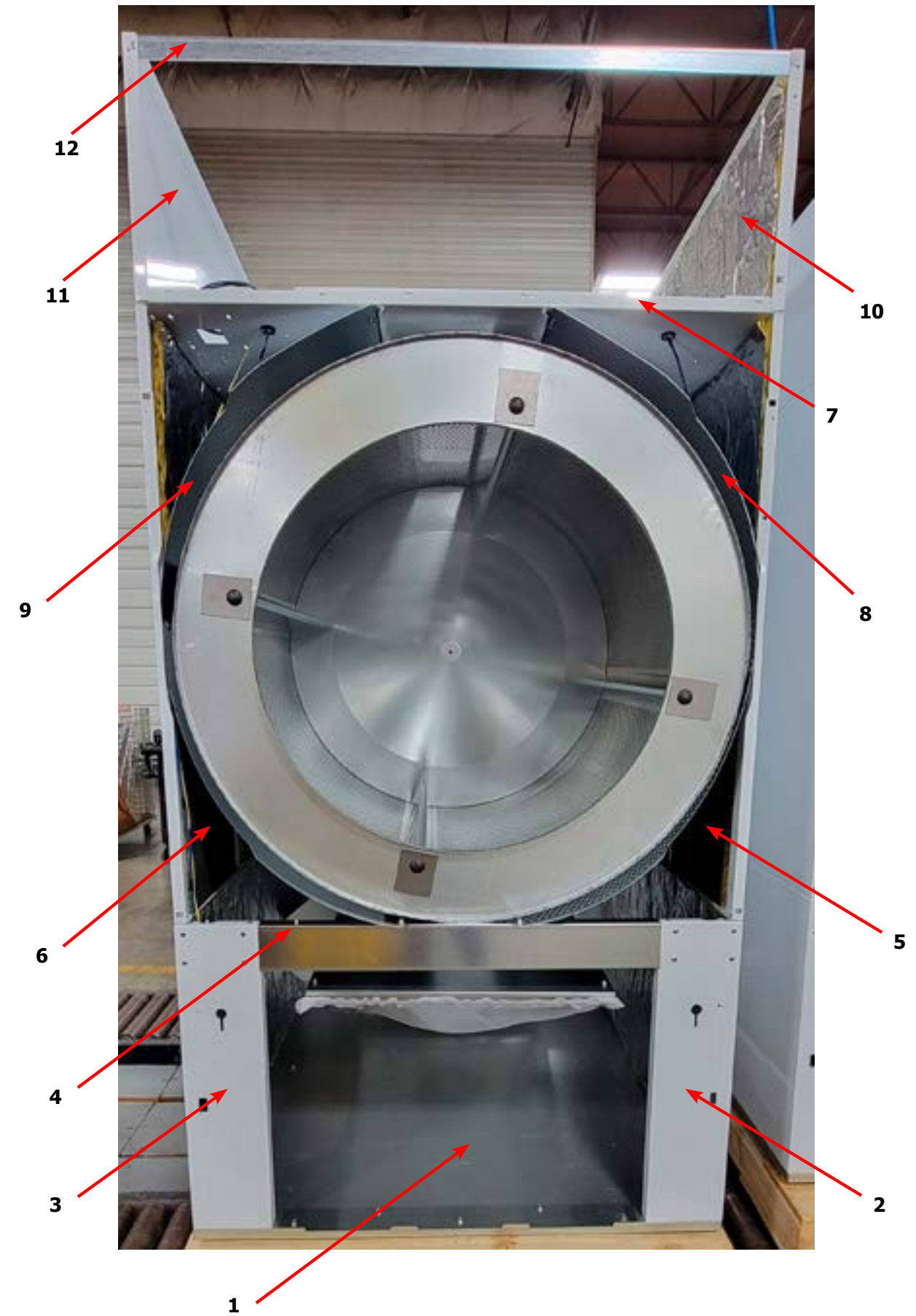



## Dryer Rear View 50 Lb Reversing

Key	Description	T-80	QTY
1	CoverImpeller-Motor Mounting, Reversing	9074-378-002	1
2	Motor, Blower-Marathon	9376-331-001	4
*	Run Capicator	5191-108-003	1
*	Start Capicator	5191-109-003	1
*	Screw HXCAP, 3/8-16x3/4 (Motor mounting to Plate)	9545-029-008	4
*	Lock-Washer, 3/8" (Motor mounting to Plate)	8641-582-003	4
*	Gasket, Motor Plate	9206-428-002	1
*	Impeller w/set screw	9278-037-003	1
3	Nut-3/8-16, Plate to cabinet	8640-415-004	4
4	Motor-Drive, Inverter	9376-319-001	1
*	Bushing-Motor mounting	9053-074-002	2
5	Rod-Motor Mounting	9497-222-008	1
6	Collar-s/Set Screws	9076-052-002	1
7	Pulley-Motor Drive	9453-169-012	1
*	Screw-Set, 5/16-18x1/2"	9545-028-013	2
8	Hook "S" type	9248-022-002	3
9	Chain-Motor Tension, 17" or 32 Links	9099-012-003	1
10	Spring, Motor Tension	9534-319-002	1
*	Tolerance Ring	9487-234-005	1
11	Pulley, Driven	9908-047-002	1
12	Washer-Flat, 1/2	8641-581-026	1
13	Washer-Lock, Ext. tooth, 1/2	8641-582-016	1
14	Bolt-3/4, 1/2-13x1/14	9545-017-009	1
15	Belt Drive	9040-076-004	1
16	Thermostat-Overtemp, Reset	9576-207-006	1
*	Screw, 10AB x 3/8	9545-008-024	2



6

5

8

9

## Dryer Rear View 50 Lb Reversing

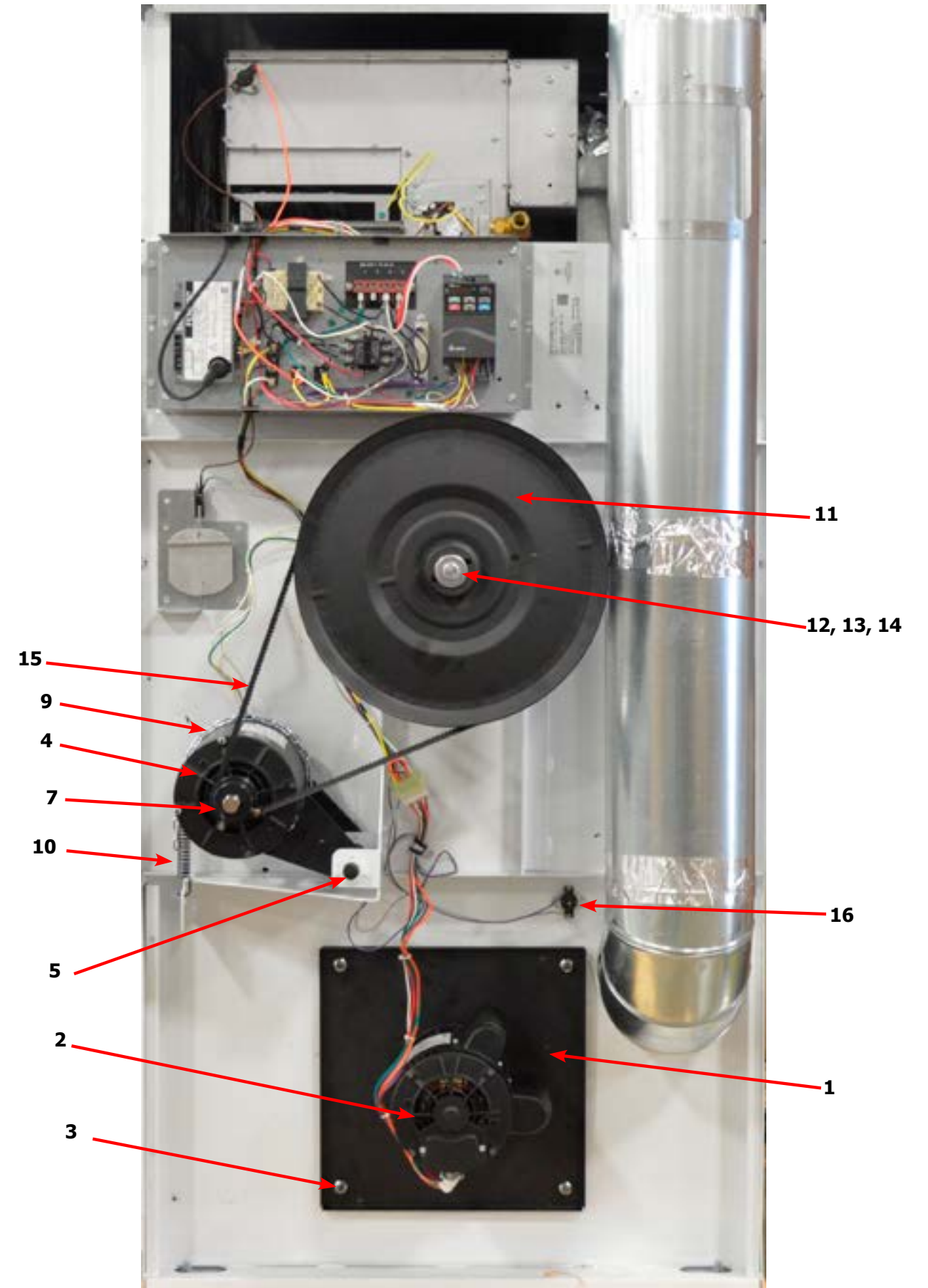

11

12, 13, 14

15

9

4

7

10

16

5

2

1

3



# Dryer Rear View-Guard & Exhaust

Key	Description	T50	QTY
1	Cover Cabinet	9074-348-001	1
*	Screw-5/16, 10ABx3/8	9545-008-024	6
2	Cover-Control Box	9074-353-001	1
3	Screw-5/16, 10ABx3/8	9545-008-024	1
4	Guard, RH	9208-140-001	1
*	Screw-5/16, 10ABx3/8	9545-008-024	4
5	Guard Base & LH	9208-138-001	1
*	Screw-5/16, 10ABx3/8	9545-008-024	4
6	Guard-Lower	9208-099-001	1
7	Screw-5/16, 10ABx3/8	9545-008-024	7
8	Guard-upper	9208-139-001	1
*	Screw-5/16, 10ABx3/8	9545-008-024	7
9	Elbow-90 degree, 8"	9142-039-001	1
10	Pipe-Duct, 8"	9109-121-001	1
11	Tee-Duct, Recirculation, 8"-6"	9810-018-001	1
12	Damper	9125-002-001	1
*	Pin-Damper, Hinge	9451-146-002	1
*	Nut-Spring	8520-141-000	2
13	Bracket-Recirculation Duct, Small	9029-228-001	1
14	Pipe-Duct, 6"	9109-122-002	1
15	Bracket-Duct, Recirculation Large	9029-247-001	1
16	Elbow-90 degree, 6"	9142-039-002	1
*	Manual-Operators	8514-279-001	1
17	Diagram & Schematics	9506-806-001	1
18	Label-Warning & Notice	8502-763-001	1
19	Label-Instructions	8502-645-001	1
20	Decal-Lighting & Clearance	8527-151-001	1
21	Label-High Voltage	8502-614-004	1
*	8" Slide Open Clean Out Duct (Optional)	9973-034-001	1

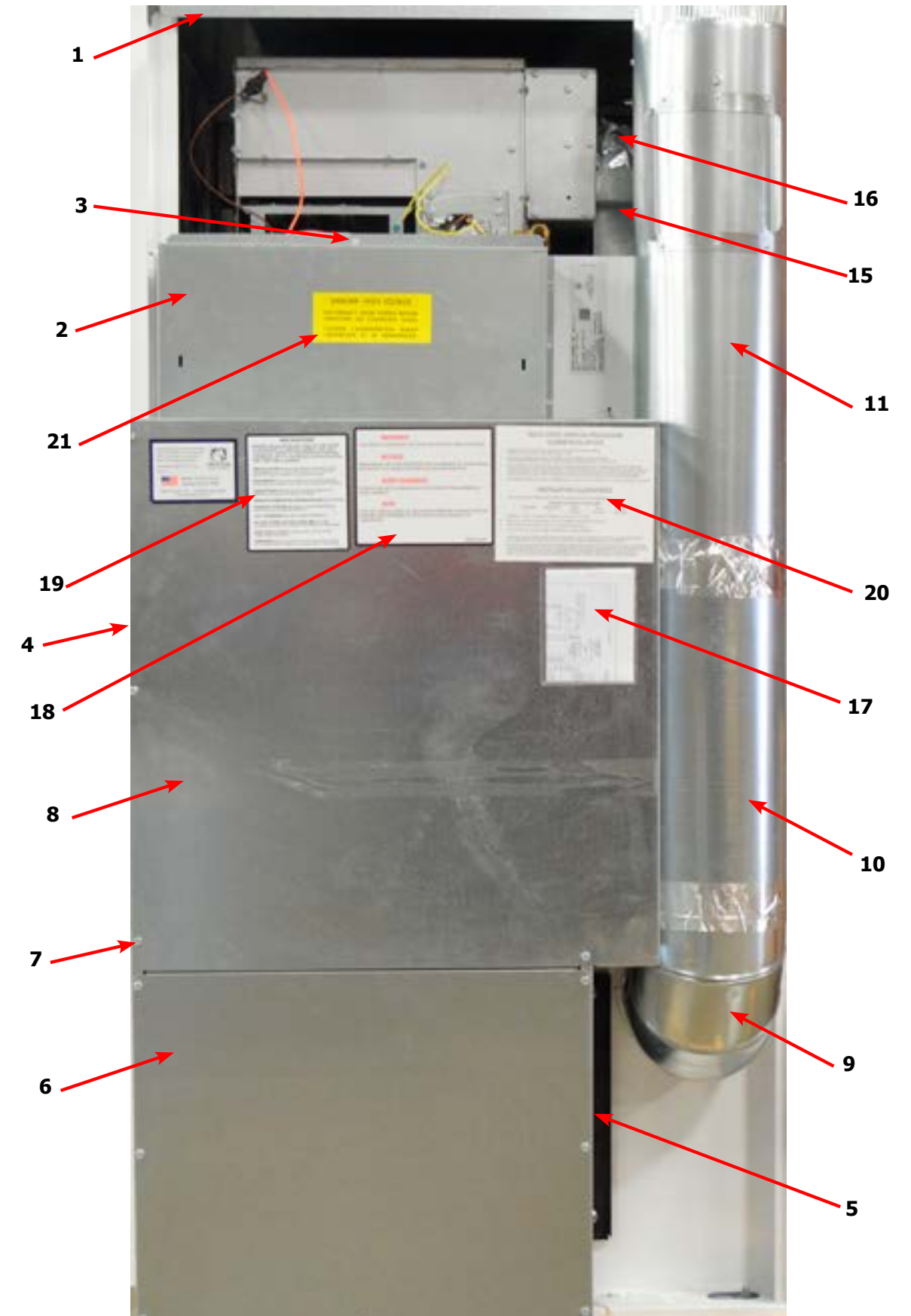
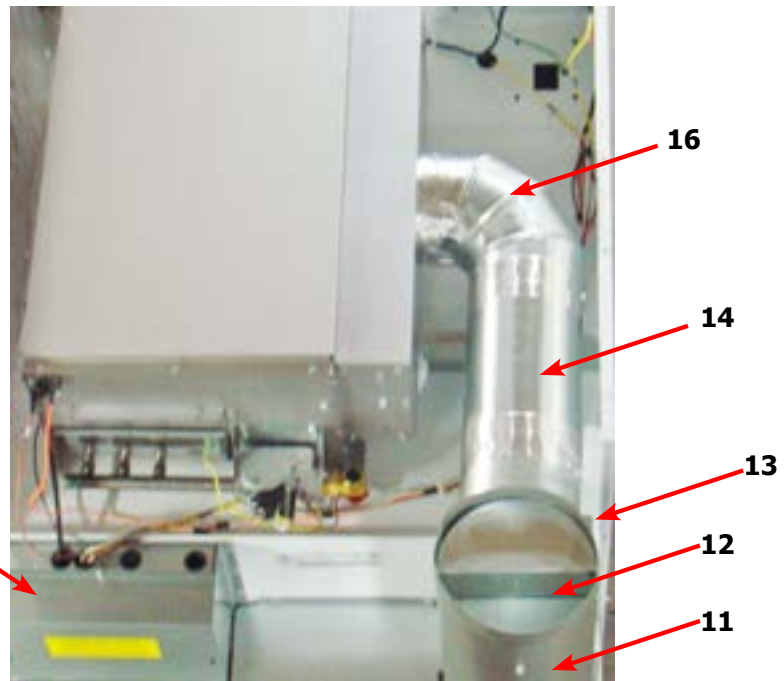

## Dryer Rear View-Bearing Housing 50Lb

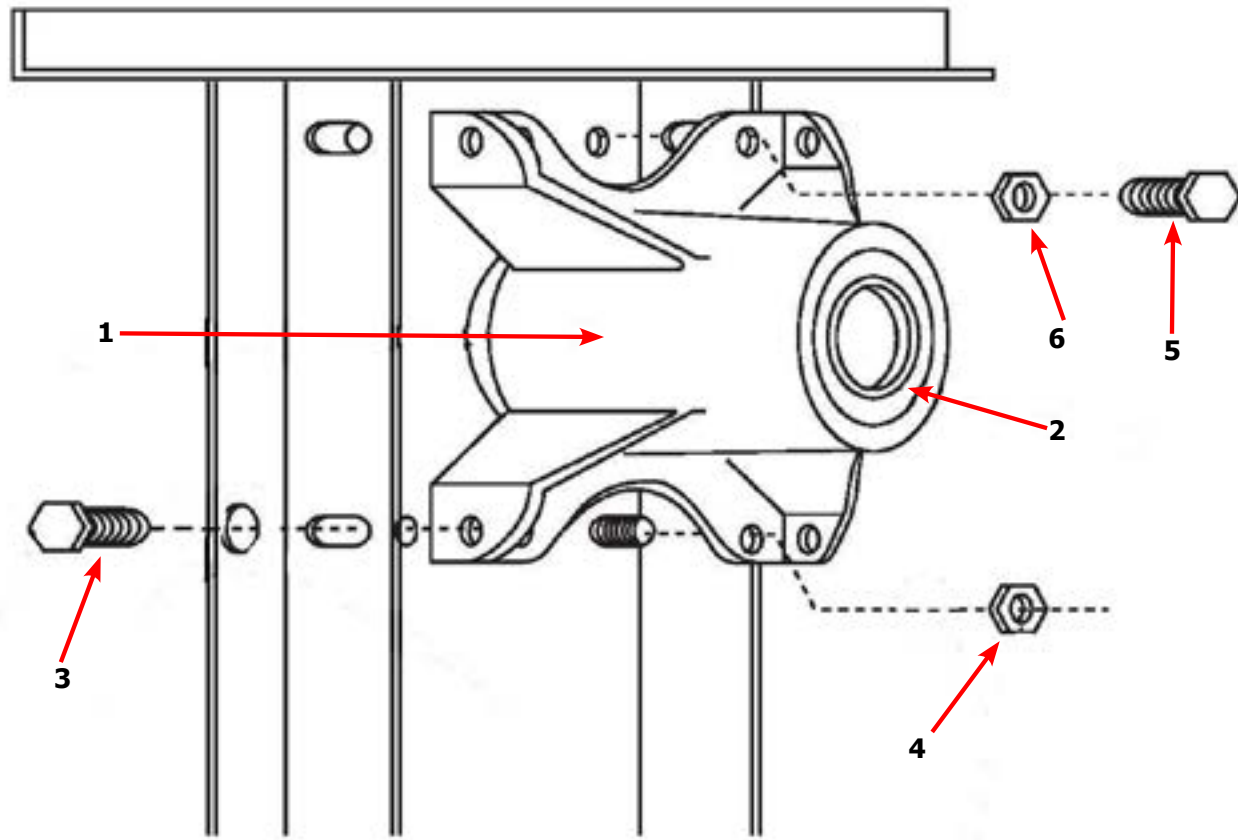

Key	Description	T-50	QTY
	Bearing Housing Complete Assy (Includes bearings & Spacer)	9803-201-001	1
1	Housing, Bearing	9241-189-002	1
*	Bearing, Ball, Front	9036-159-001	1
*	Spacer, Bearing	9538-183-001	1
2	Bearing, Ball, Rear	9036-159-003	1
3	Screw-Wizlock, 1/2-13x3/4	9545-017-017	4
4	Nut, 1/2-13	8640-417-002	2
5	Screw, 1/2-13x1 1/2	9545-017-018	2
6	Nut, 1/2-13	8640-417-002	2

## Dryer Tumbler Group 50Lb

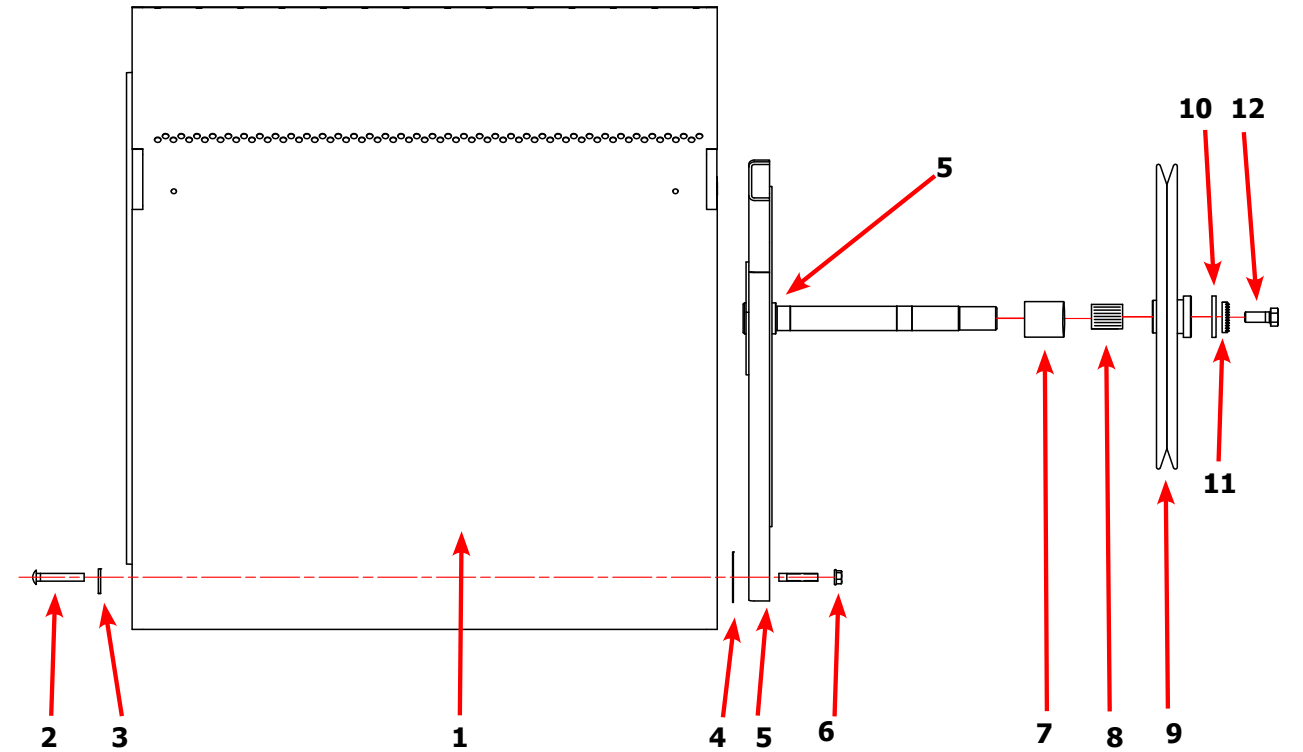

Key	Description	T-50	QTY
*	Tumbler Assy Complete W/Spider (GALV)	9848-154-001	1
1	Tumbler Assy (Galvanized)	9848-148-001	1
*	New Tumbler, Taller Baffles (Anti-Roping), W/Spider	9848-158-001	1
*	New Tumbler, Taller Baffles (Anti-Roping)	9848-157-001	1
*	Tumbler Assy Complete W/Spider (SS & Galv front)	9848-154-002	1
1	Tumbler Assy (Stainless Galvanized front)	9848-148-002	1
2	Rod, Tumbler	9497-226-002	3
3	Washer, Special	8641-590-002	3
4	Shim	9552-013-003	AR
5	Spider Assy	9568-017-001	1
6	Nut, Wiz Lock	8640-417-005	3
7	Spacer-Shaft	9538-188-001	1
8	Tolerance Ring	9487-234-005	1
9	Pulley, Driven	9908-047-002	1
10	Washer -Flat	8641-581-026	1
11	LockWasher - IntTooth, 1"	8641-582-016	1
12	Screw, 1/2-13x1 1/4	9545-017-009	1

# Dryer Burner Housing Group 50Lb

Key	Description	Part Number	Qty
	Housing Assembly, Burner	9803-211-001	1
1	Panel-Burner Housing, Front	9454-863-001	1
2	Panel-Burner Housing, Side Right	9454-861-001	1
3	Panel-Burner Housing, Side Left	9454-862-001	1
4	Panel-Burner Housing, Back	9454-864-001	1
5	Baffle-Burner Housing, Center	9049-098-001	1
6	Panel-Burner Housing, Top	9454-849-001	1
7	Panel-Burner Housing, Top	9074-343-001	1
8	Baffle-Burner Housing, Extention	9049-100-001	1
9	Duct Adaptor, 6"x1.25" long	9109-120-003	1
10	Baffle-Burner Housing, Recirculation	9049-099-001	1
11	Side-Extention Baffle, Burner Housing	9551-049-001	2
12	Bracket-Support, Burner	9029-213-001	1
13	Burner, Main	9048-021-001	3
14	Screw, 10T-32x1/2	9545-008-008	3
15	Electrode-Ignition	9875-002-003	1
16	Cover-Burner, Intet	9074-344-001	1
17	Bracket-Support, Gas Valve	9029-227-001	1
18	Control Assy,Gas Valve, White Rodgers 36J	9857-192-001	1
19	Screw, #8-32x3/8	9545-010-014	4
20	Valve-Gas Shutoff, (Optional)	9379-196-001	1
21	Manifold Assy	9381-010-003	1
*	Orfice-Natural, #30	9425-069-002	3
*	Orfice-LP, #48	9425-069-003	3
*	Kit, LP Conversion, White Rodgers	9732-102-017	1
23	Thermostat-HI-Limit	9576-203-002	1
24	Spacer-1/4x5/8 long	9538-166-009	2
25	Screw-8Bx1	9545-045-013	2
26	Screw, 10Bx1/4	9545-008-001	22
27	Screw, 10ABx3/8	9545-008-024	31

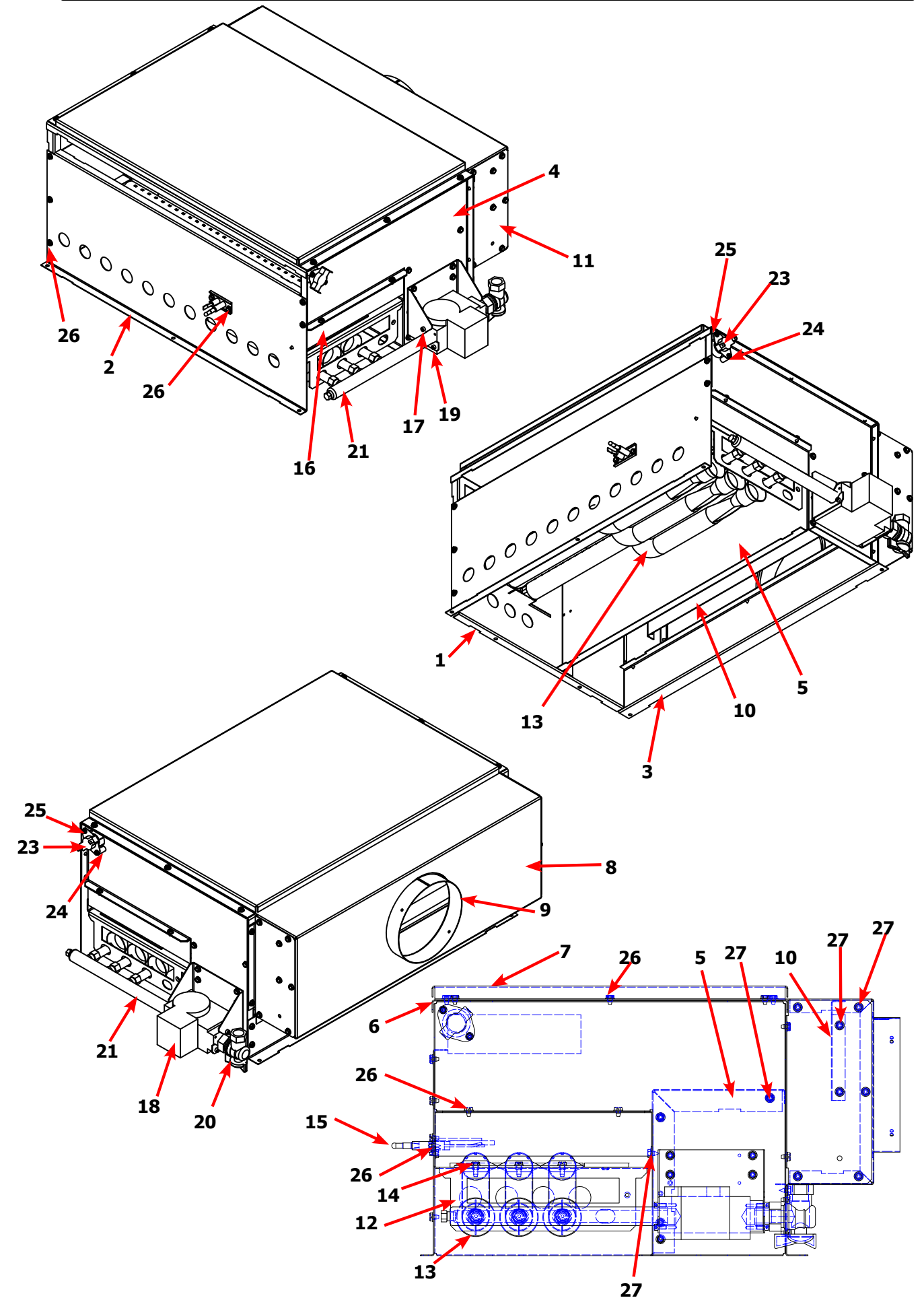





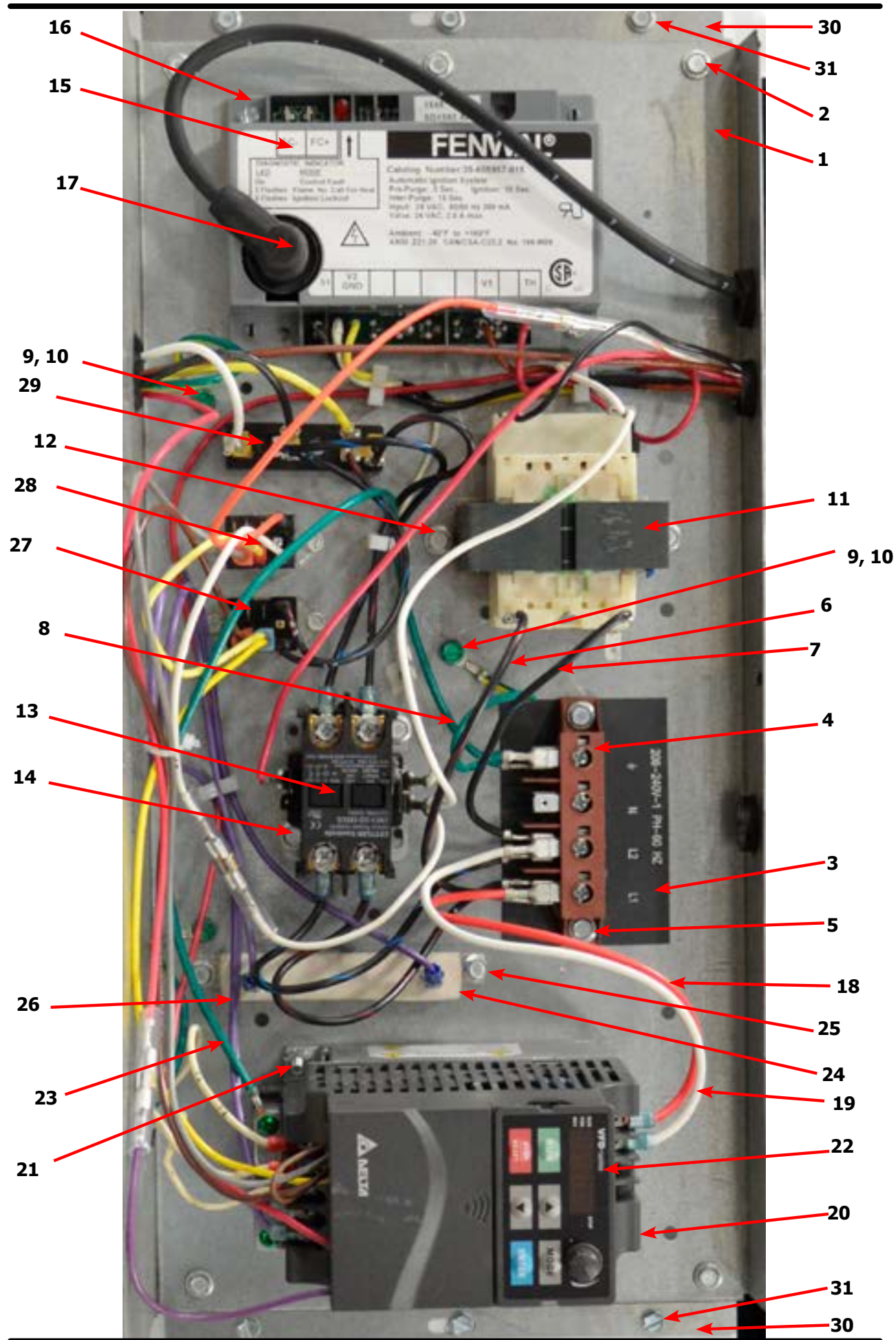

## Dryer Rear View-Control Box

Key	Description	T50	QTY
1	Wrapper-Control Box	9636-203-001	1
2	Screw, 5/16-10AB-3/8	9545-008-001	6
*	Cover-Control Box	9074-353-001	1
*	Screw, 5/16-10AB-3/8	9545-008-024	1
3	Strip-Marker, Terminal	9558-029-005	1
4	Terminal Block Assy-Power, 4Pole	9897-035-001	1
5	Screw, 5/16-10AB-3/8	9545-008-024	2
6	Wire assy-Blk/Red, 6 1/2"	8220-001-230	1
7	Wire assy-Blk/Blu, 6 1/2"	8220-001-231	1
8	Wire Assy, GRN, 7"	8220-001-478	1
9	Screw- 10-32TTx1/2 GRN	9545-008-027	2
10	Lockwasher, External tooth	8641-582-006	2
11	Transformer, w/Circuit braker	8711-007-002	1
12	Screw, 5/16-10AB-3/8	9545-008-024	2
13	Relay-Motor, 30Amp, 24VAC	5192-299-002	1
14	Screw, 5/16-10AB-3/8	9545-008-024	2
*	Wire assy-Blk/Red, 9"	8220-146-001	2
*	Wire assy-Blk/Blu, 9"	8220-146-002	2
15	Control Assy, Ignition (Module)	9857-182-001	1
16	Screw-8Bx3/4"	9545-045-007	2
*	Harness, Ignition Module	9627-867-009	1
17	Wire Assy- High Voltage Lead	9631-403-009	1
18	Wire Assy-Red, 12"	8220-067-004	1
19	Wire Assy- White, 12"	8220-067-003	1
20	Drive-VFD Inverter, 1HP, 120VAC	9375-032-011	1
*	VFD Cooling Fan	9189-013-001	1
21	Nut, #10-32UNF	8640-413-002	4
22	Display-Inverter Drive	9150-044-001	
23	Wire Assy-Green, 18"	8220-092-006	1
*	Wire Assy-BRN, 19"	8220-078-019	1
*	Wire Assy-Yellow, 20"	8220-082-002	1
*	Wire Assy-Gray, 18"	8220-078-018	1
*	Wire Assy, Brown 3"	8220-057-035	1
24	Resistor-Dynamic Breaking, 200OHM	9483-004-002	1
25	Screw-5/16, Mounting Resistor, 10ABx3/8	9545-008-024	2
26	Wire Assy, Violet 24"	8220-118-001	2
*	Screw, 6-32 x 5/16"	9545-044-006	2
*	Nut, #6-32	8640-411-003	2
27	Relay, 120VAC	5192-285-002	1
28	Relay, 24VAC	5192-285-004	1
*	Wire Assy-BLK/BLU, 15"	8220-063-021	1
*	Wire Assy-BLK/RED, 12"	8220-063-010	1
29	Terminal Block	9897-039-001	1
*	Screw, 6B X 3/8	9545-031-003	1
30	Bracket, Control Box	9029-294-001	2





