



DEXTER[®]
LAUNDRY

**USE THE BLUE TABS LOCATED ON THE
RIGHT AND LEFT SIDES OF THE FOLLOWING
DOCUMENT TO ADVANCE TO EACH SECTION.**

Kits, Assemblies, & Common Parts

Loading Door Components	Part Number
Door Handle	9244-082-001
Door Close Switch	9539-461-001
Electrical Components	Part Number
Transformer, Control	8711-007-001
Controls	9732-249-001
Heating Circuit Components	Part Number
Ignition Control Module	9857-116-003
Ignition Electrode Assembly	9875-002-003
Thermostat, Hi-Limit	9576-203-002
Thermostat, Overtemp	9576-207-006
Fuseholder	9200-001-002
Fuse 1.5 amp	8636-018-001
Airflow Switch	9539-461-009
Cabinet Components	Part Number
Cleanout Duct Assembly 8"	9973-034-001

Section 6: Parts Data

Cabinet Group

Key	Part Number	Description	Qty
*	9960-256-021	Door Assy., Loading Complete-Wht	1
*	9960-256-025	Door Assy., Loading Complete-SS	1
1	9960-255-007	Door Assy.ONLY, Loading-SS	1
2	9982-280-002	Plate Assy., Hinge (Wht)	1
2	9982-280-011	Plate Assy., Hinge (SS)	1
*	9545-012-015	Screw, Hinge to Door 10-32 x 3/8"	4
*	8640-413-002	Nut, Hinge to Door #10-32 UNF	4
3	9212-002-003	Glass, Door	1
4	9206-164-009	Gasket, Glass	1
*	9548-117-000	Support, Door Glass (inside gasket)	1
5	9206-420-002	Gasket, Outer Rim	1
6	9244-082-001	Handle, Loading Door	1
*	9545-018-017	Screw, Handle 1/4"-20 x 3/8"	2
*	9531-033-001	Stud, Door Catch	1
*	8640-413-001	Nut, Hex	1
*	8640-413-003	Nut , Acorn # 10-32	1
*	9086-015-002	Catch, Loading Door	1
7	9989-460-003	Panel Assy., Front- white only	1
7	9989-460-001	Panel Assy., Front- S. Steel	1
8	9108-100-004	Door, Upper Service-S.S	1
8	9108-100-006	Door, Upper Service-White	1
9	9578-090-002	Trim, Door-Upper Service	1
*	6292-006-006	Key (only) (FJWCC)	1
10	8650-006-003	Lock w/ nut, Upper Service Door	1
*	9491-009-001	Rivet, Drive	2
*	8641-581-005	Washer, Flat 3/16"	2
*	9548-268-001	Support, Upper Door	1
11	9412-127-001	Nameplate, Industrial Dryer	1
12	9545-012-003	Screw, Chrome 10-32 x 1/2"	4
*	8641-436-004	Washer, Fiber	4
*	8641-582-019	Lockwasher # 10	10
*	8640-399-001	Nut, Spring U type 10Z	6
13	9544-047-002	Strap, Hinge (White)	1
13	9544-047-007	Strap, Hinge (Gray)	1
*	9545-012-003	Screw, to Panel 10T-32 x 1/2" Strap	4
14	9545-052-001	Screw, Door to Hinge Strap (special)	1
*	8641-436-003	Washer, Fiber/ Plastic on Door Hinge (special)	1
15	9960-281-001	Door Ass'y, Lower Service-SS	1
15	9960-281-003	Door Ass'y, Lower Service-White	1
16	9578-088-001	Trim, Door - Lower Service	1
17	9545-008-021	Screw,Pn Hd Cr., #10Bx3/8	5
18	9578-084-002	Trim, Kick- Lower Service Door	1
19	9545-008-010	Screw, Tr Hd Cr-#10x1/2 Blk	3
20	9244-084-001	Latch, Lower Door (Handle)	1
23	9435-016-003	Overlay Trim	1
*	8502-617-001	Label - Made in the USA	1
*	9277-051-002	Insulation Side Panel	6

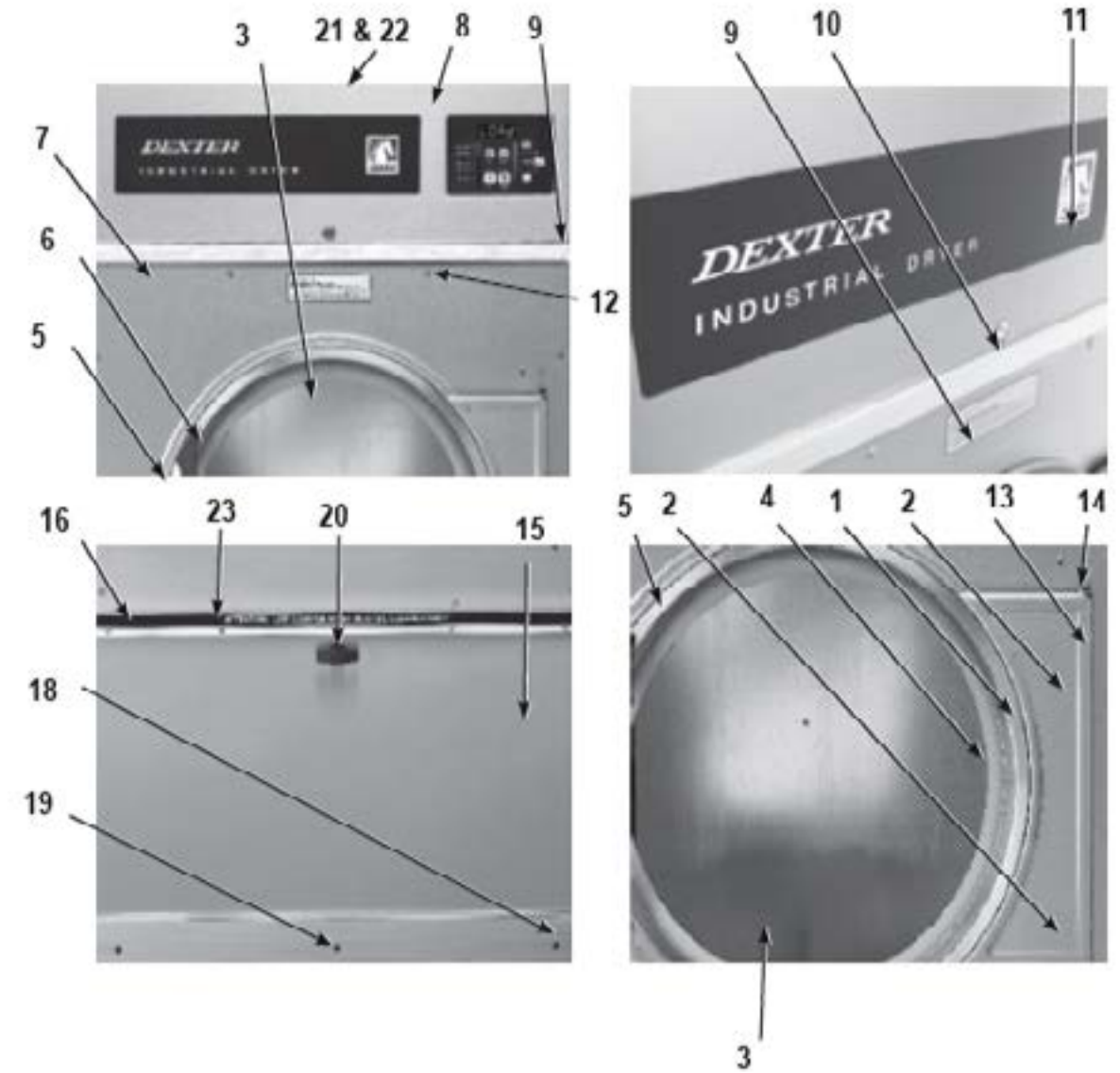

Key	Part Number	Description	Qty
*	9277-049-002	Insulation Front Panel Bottom	1
*	9277-049-001	Insulation Front Panel Top	1
*	8544-006-001	Leg, Leveling	4
*	9049-074-001	Baffle, Cabinet- Left Inside Cabinet	1
*	9049-074-002	Baffle, Cabinet- Right Inside Cabinet	1
*	9545-008-003	Screw, #10x1/2 TEK	8
21	9074-273-001	Cover, Cabinet	1
22	9545-008-024	Screw 10AB x 3/8"	10
*	9277-050-002	Insulation Lower Service Door	1
*	9277-047-001	Insulation	1
*	9277-047-002	Insulation 1/4" black	1

Drive Group

Key	Part Number	Description	Qty
1	9376-299-002	Motor, Drive	1
*	9732-205-008	Motor Replacement Kit	1
*	9545-014-004	Screw, Hx 5/16-18 x 5/8"	4
*	8640-400-003	Nut 5/16-18	4
2	9453-157-001	Pulley, Motor	1
*	9545-028-013	Screw, Set	2
3	9991-054-002	Support Assembly, Motor	1
4	9545-029-005	Screw 3/8-16 x 1 1/4"	4
4	8640-415-004	Nut 3/8-16	4
5	9991-053-001	Support Assembly, Intermed. Pulley	1
6	9545-029-010	Bolt, Rd Hd, 3/8-16 x 1 1/4"	3
7	9545-029-003	Screw, 3/8-16 x 1 1/2"	1
8	8640-415-004	Nut 3/8-16	3
*	8641-581-035	Washer, Flat	4
9	9861-024-003	Arm Assembly-Tension	1
*	8641-581-035	Washer, Flat	1
*	9487-200-006	Ring-Retaining	1
10	9908-042-006	Pulley Assembly, Intermediate - w/bearings	1
11	9036-159-007	Bearing, Ball-Idler Pulley	2
*	9538-173-002	Spacer, Bearing	1
12	9908-043-002	Pulley Driven	1
*	9487-234-001	Ring, Tolerance	1
13	8641-581-026	Washer, Flat	1
13	8641-582-016	Lockwasher	1
13	9545-017-009	Screw, Hx Cap	1
14	9040-077-004	Belt, Final Drive	1
15	9040-077-003	Belt, Motor Drive	1
16	9534-151-000	Spring, Belt Tension	1
17	9099-012-002	Chain, Spring Tension	1
18	9248-022-002	Hook, Tension	1
21	9208-067-001	Guard, Drive	1
22	9454-685-001	Panel, Drive Guard, RH	1
23	9454-686-001	Panel, Drive Guard, LH	1
24	9550-175-001	Shield, Motor	1
25	9545-008-003	Screw	2
26	9545-008-024	Screw (to attach to guards above)	24
19	9074-275-004	Blower Impeller Cover (flat)	1
20	9074-275-005	Blower Impeller Cover (formed)	1

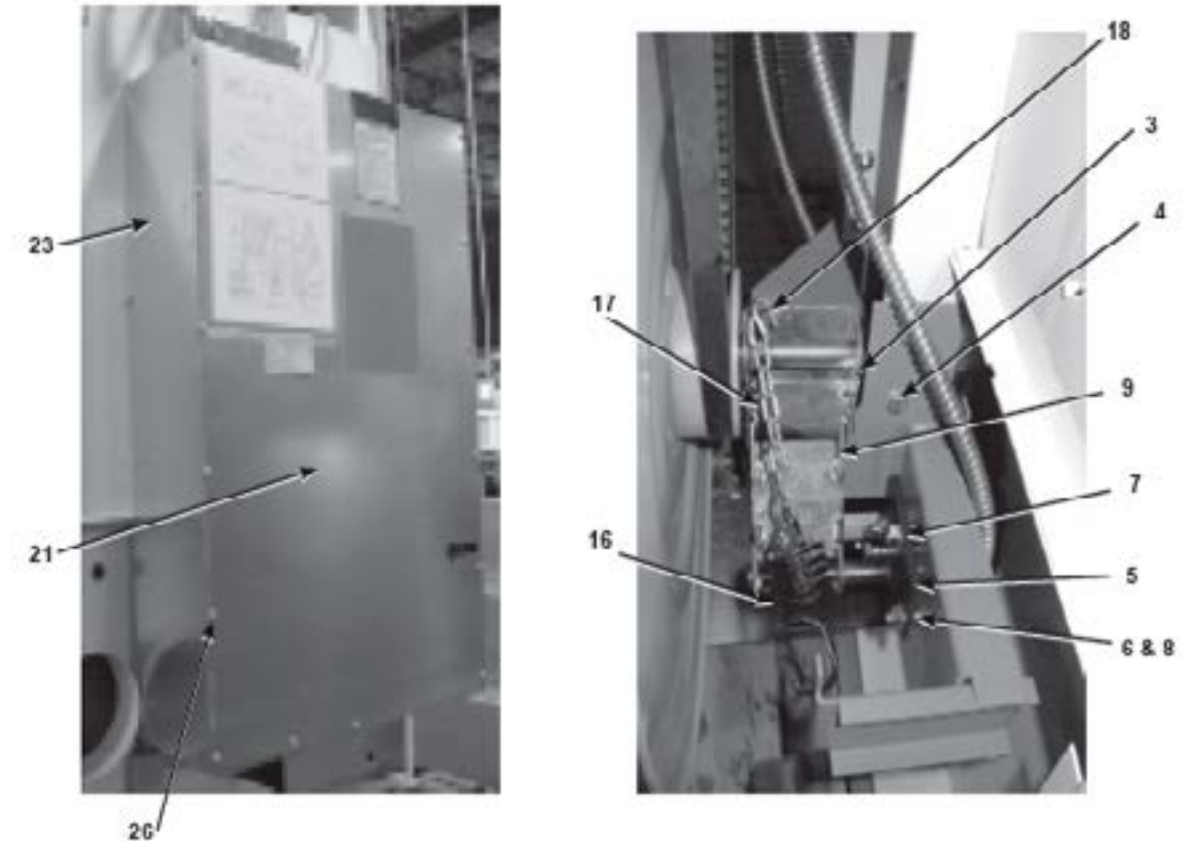
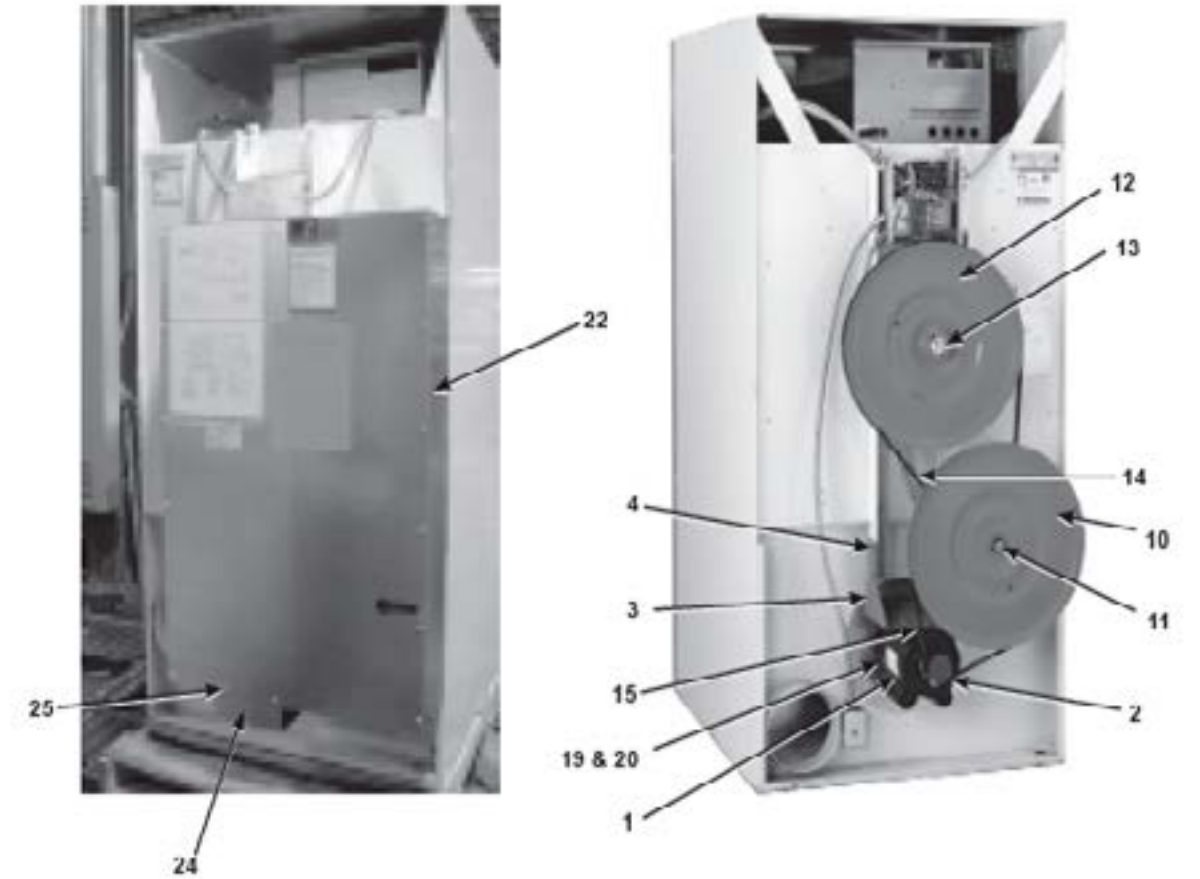

Rear Control Group

Key	Part Number	Description	Quantity
1	9041-081-001	Box , Control.....	1
*	9074-304-001	Cover, Control Box Upper.....	1
*	9545-008-024	Screw 10AB x 3/8".....	4
2	5192-295-011	Relay (Large).....	1
*	9545-044-002	Screw, #8ABx 3/8.....	2
3	9897-035-002	(4 Pole) Terminal Block Assembly, Power	1
4	9558-029-003	Strip , Terminal Marker (4 Pole).....	1
*	9545-045-002	Screw, #8ABx 3/8.....	2
*	8641-582-006	Lockwasher, Ex Tooth # 10.....	1
*	9074-305-001	Cover control box lower.....	1
5	8639-621-007	Screw #10-32 x 1/2 GRN.....	1
*	8640-411-003	Nut Hexkeys #6-32.....	2
6	8711-007-001	Transformer.....	1
*	9545-012-009	Screw--#10-32 x 1/2" Mount Transformer	2
*	8640-413-002	Nut Hexkeys #10-21 UNF Mount Transformer	2
*	8220-001-230	Wire Assembly Black/Red 8 1/2".....	1
*	8220-001-231	Wire Assembly Black/Blue.....	1
*	8220-001-452	Wire Assembly White 12 1/4".....	1
*	8220-001-478	Wire Assembly Green 7".....	1
*	8220-067-001	Wire Assembly Black/Red 7 3/4".....	1
*	8220-067-002	Wire Assembly Black/Blue 7 3/4".....	1
7	9897-034-001	Terminal Block Assembly (6 pole).....	1
*	9558-027-001	Strip Terminal Marker (6 pole).....	1
*	8220-001-230	Wire Assembly Black/Red 8 1/2" Jumper	1

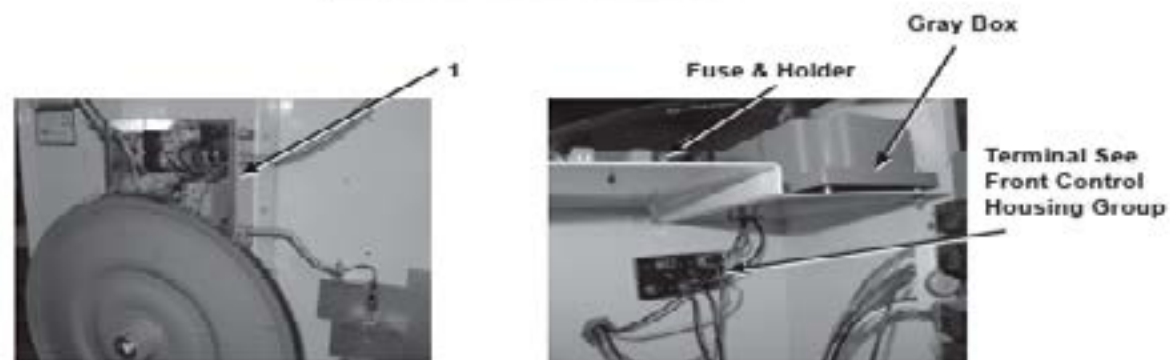
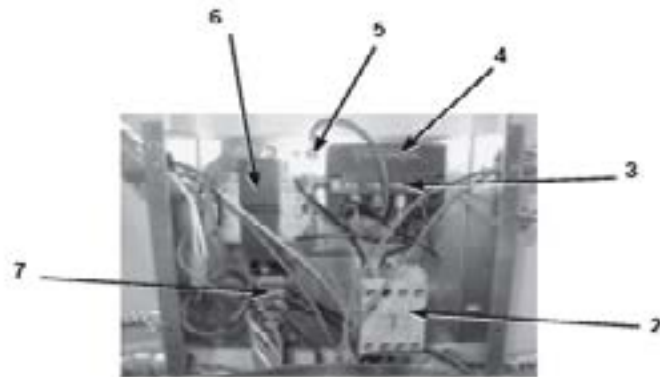

Door Switch Group

Key	Part Number	Description	Quantity
1	9041-076-001	Box, Door Switch.....	1
2	9550-159-001	Shield, Door Switch.....	1
3	9539-461-007	Switch, Door.....	1
4	8640-401-001	Nut, Special Twin #4-40.....	1
5	9545-020-001	Screw, Pn Hd Sl.#4-40x5/8.....	2
6	9074-255-001	Cover, Switch Box.....	1
7	9545-008-020	Screw, Box Cover 10 AB x 3/4".....	2
8	9008-004-001	Actuator, Switch.....	1
9	6068-041-001	Conduit Special.....	1
10	9545-012-003	Screw. 10-32 x 1/2".....	1
*	8641-436-000	Washer, Fiber.....	1
11	8640-413-004	Nut, ElasticStop 10 -32.....	1

* Not Illustrated

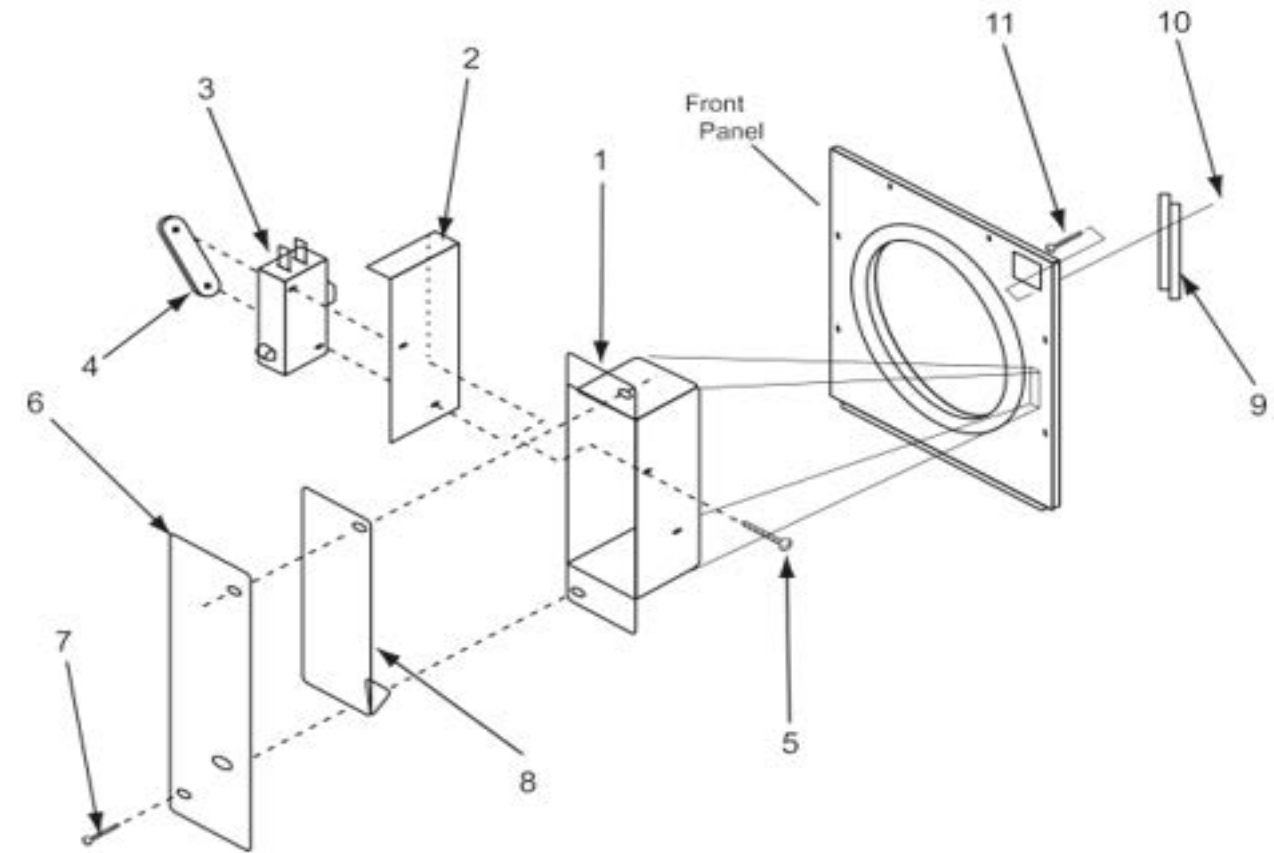

Burner Housing Group

Key	Part Number	Description	Quantity
1	9803-195-001	Housing Assembly, Burner	1
*	9545-008-024	Screw	4
2	9048-018-001	Burner, Main	4
*	9545-008-008	Screw 10T-32 x 1/2	4
3	9875-002-002	Electrode, Ignition	1
4	9452-645-001	Plate, Electrode Mtg	1
5	9545-045-001	Screw, Electrode Mtg 8B x 11/4"	2
6	9857-134-002	Control Assy, Gas	1
7	9381-011-001	Manifold, Assy 4 port	1
*	9425-069-021	Orifice, Burner-Natural	4
*	9425-069-022	Orifice, Burner-LP	4
8	9576-203-002	Thermostat, Hi-Limit	1
*	9538-142-001	Spacer, Hi-Limit	2
*	9545-045-007	Screw 8B x 3/4"	2
19	9074-234-001	Cover, Hi-Limit Stat	1
*	9545-008-024	Screw 10 B x 3/8"	1
*	9857-116-003	Control, Ignition (Gray Box)	1
*	9545-044-002	Screw 6-32 x 1"	2
*	8640-411-003	Nut, Hex Keps #6-32	2
*	9897-026-001	Terminal Block Power (Inside Control Panel)	1
*	9545-031-004	Screw 6 AB x 5/8"	2
*	9039-915-001	BRACKET, Pipe gas line	1
*	9545-008-003	Screw 6AB x 5/8"	2
21	9631-403-003	Wire Ass'y, High Voltage	1
20	9627-711-001	Harness, Low Voltage Ignition	1
*	9054-045-001	Fuseholder	1
*	8636-018-001	Fuse 1.5 amps	1
*	8711-007-001	Transformer, Control (In rear control box)	1
*	9545-008-026	Screw, #10x1/2"	2
*	9732-102-010	Kit, LP Conversion 4 Burner	1
13	9548-280-001	Support, Front Burner	1
14	9545-008-008	Screw 10T-32 x 1/2"	1
*	9454-731-001	Left side burner housing	1
*	9454-730-001	Right side burner housing	1
9	9379-164-002	Valve, Gas Shut-Off w/ brass union	1
*	9458-020-003	Pipe, Gas Line	1
*	9454-737-001	Front Side Burner Housing	1

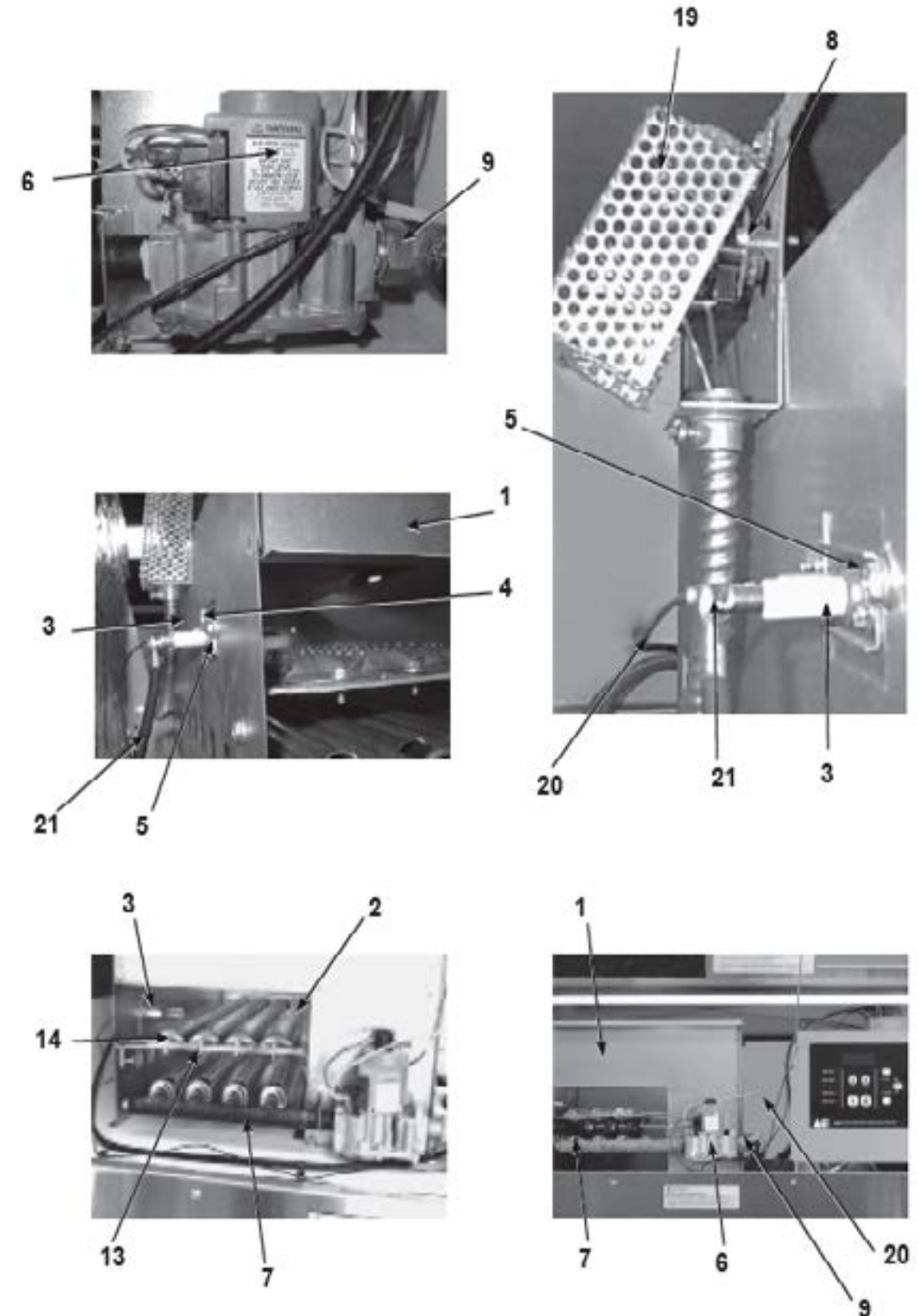

Bearing Housing Group

Key	Part Number	Description	Qty
*	9803-189-001	Housing, Bearing Ass'y w one(rear) bearing	1
1	9241-183-003	Housing, Bearing	1
2	9036-159-001	Bearing, Ball-Rear	1
*	9036-159-002	Bearing, Ball-Front	1
3	8641-581-026	Washer, Flat 1/2"	4
4	8641-582-004	Lockwasher spring 1/2"	4
5	9545-017-004	Bolt, 1/2-13x1	4
6	9545-059-003	Screw, 7/16-14x1 1/2	2
*	8641-582-013	Lockwasher, 7/16	2
7	8640-416-001	Nut, 7/16-14.	4
*	9487-234-001	Ring, Tolerance	1

* Not Illustrated

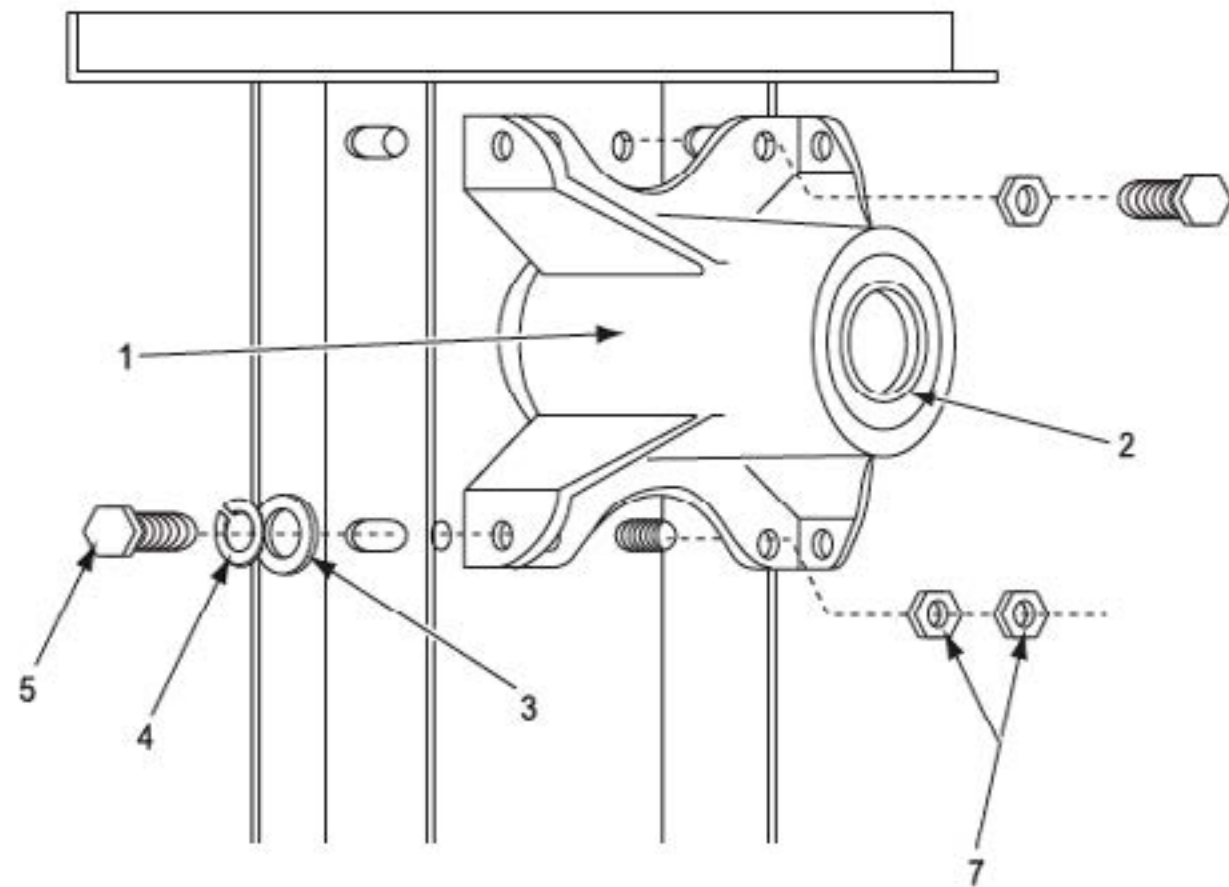

Tumbler Basket Group

Key	Part Number	Description	Qty
1	9848-118-001	Tumbler Ass'y	1
*	9848-118-002	Tumbler Ass'y SS.....	1
2	9873-005-001	Spider Ass'y with bearing on.....	1
3	9497-226-001	Rod, Tumbler	4
4	8640-417-005	Nut 1/2"-13.....	4
5	9552-013-000	Shim.....	4
7	8641-590-001	Washer, Tumbler Rod Special	4
*	9487-234-001	Ring, Tolerance.....	1
8	8641-582-016	Lock Washer ext tooth 1/2", Tumbler Shaft	1
9	8641-581-026	Flat Washer 1/2",Tumbler Shaft.....	1
10	9545-017-009	Screw, Tumbler Shaft 1/2-13 x 11/4"	1

* Not Illustrated

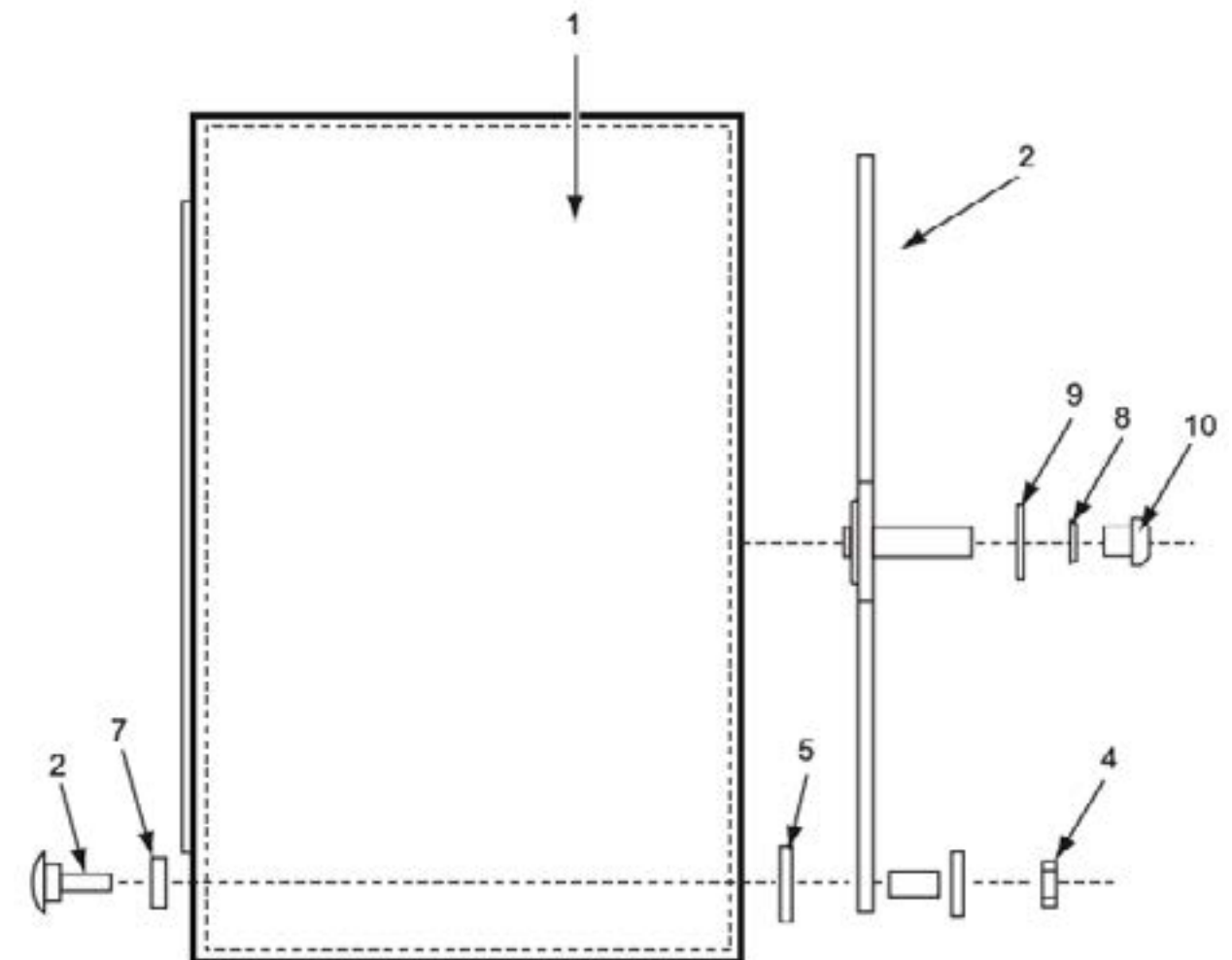

Blower Impeller and Air Flow Switch Group Over Temperature Switch

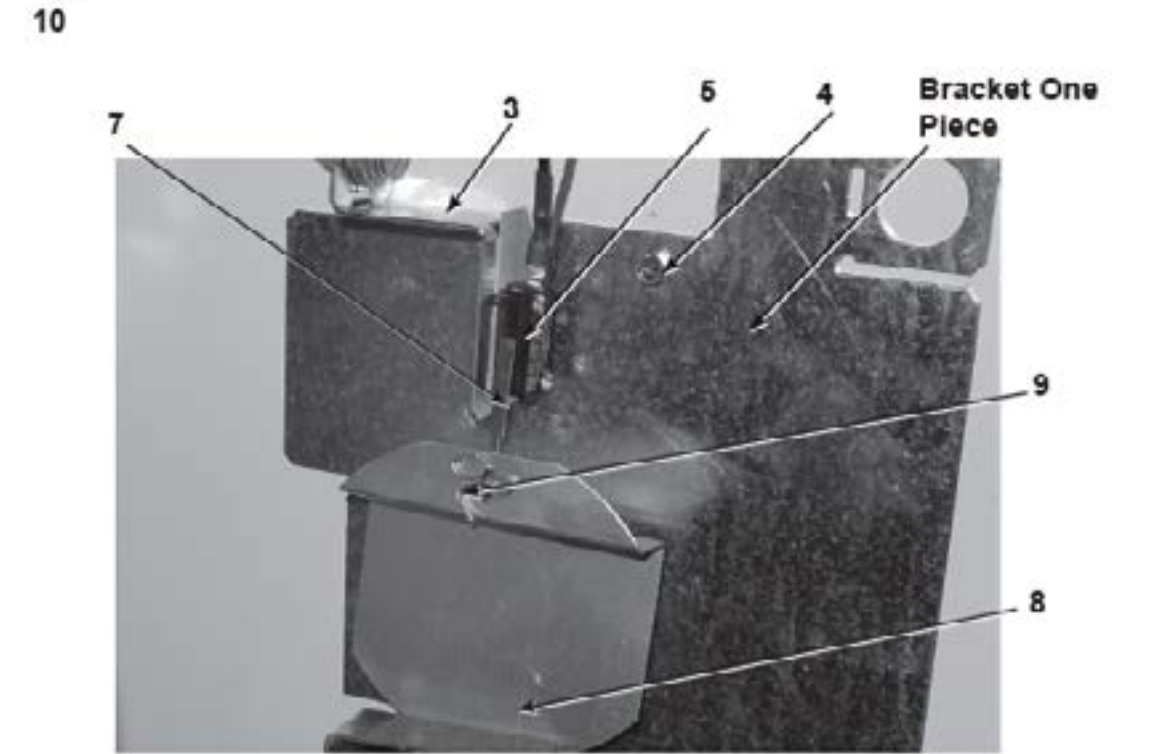

Key	Part Number	Description	Quantity
3	9029-135-001	Bracket -Switch One Piece.....	1
4	9545-008-024	Screw-10B x 1/4.....	2
5	9539-461-009	Switch-Micro.....	1
12	9545-020-001	Screw 4-40 x 5/8.....	2
*	8640-401-001	Nut Twin.....	1
8	9008-007-001	Actuator-Switch.....	1
9	9451-169-002	Pin Cotter.....	1
13	9039-575-000	Bracket Conduit.....	1
11	9825-057-002	Over-tempcoverass'y.....	1
*	9576-207-006	Thermostatover-tempMnl.....	1
*	9545-008-024	Screw 10B x 3/8.....	2
*	9550-169-003	Shield for macro switch.....	1
17	9834-009-001	Hood Assembly, Lint.....	1
*	8640-412-004	Nut, Whizlock.....	6
14	9822-031-002	Lint Screen 34" length (newest style).....	1
10	9278-037-003	Impeller, w/set screws.....	1
15	9501-004-002	Temperature Sensor Probe.....	1

* Not Illustrated

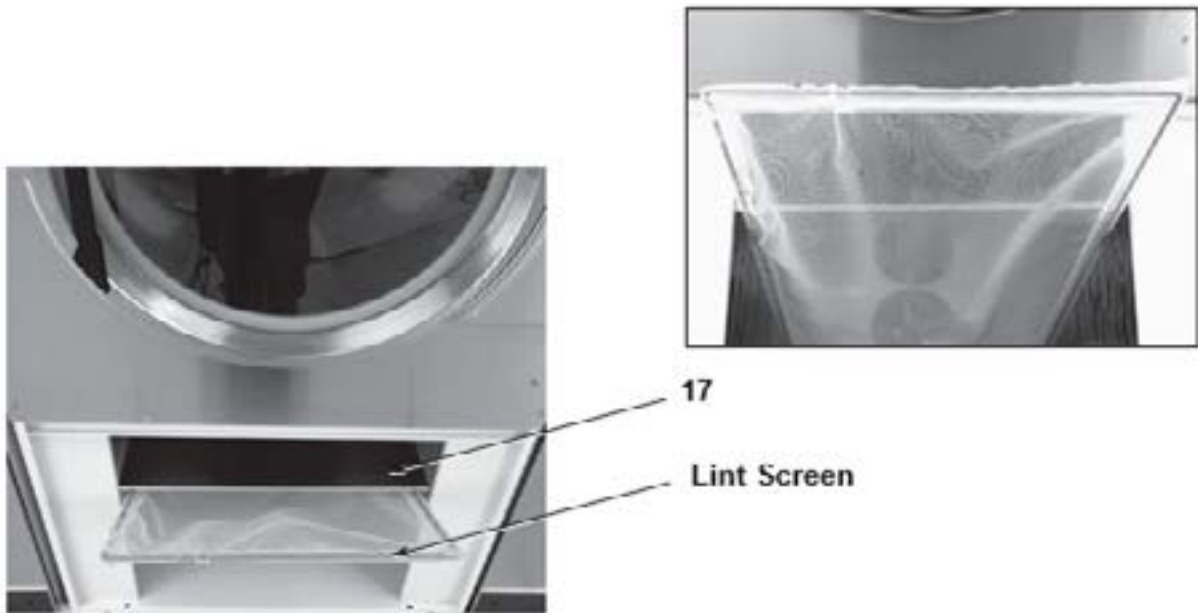

Wire & Harness Group

Key	Part Number	Description	Qty
*	8220-001-486	BRN 26".....	1
*	8220-001-499	BLK 26".....	1
*	8220-101-002	BLK 64".....	1
*	8220-101-007	Wire Assembly VIO 54".....	1
*	8220-101-004	Wire Assembly BRN 54".....	1
*	2114-008-000	Bushing Anti Short.....	1
*	8220-001-221	Door Switch Wire Assembly BLK 45".....	1
*	8220-001-222	Door Switch Wire Assembly BLU 45".....	1
*	8220-001-461	Wire Assembly WHT 58".....	1
*	8220-062-007	Wire Assembly BLK 74".....	1
*	8220-064-001	Wire Assembly GRY 61".....	1
*	8220-064-012	Wire Assembly RED 61".....	1
*	8220-065-021	Wire Assembly VIO 61".....	1
*	8640-276-003	Wire Nut #73 B ORG.....	1
*	8220-103-003	Wire Assembly GRY 64".....	1
*	8220-001-230	Wire Assembly BLK/RED 8.5".....	1
*	8220-001-231	Wire Assembly BLK/BLU 6.5".....	1
*	8220-001-452	Wire Assembly WHT 12" - 4".....	1
*	8220-001-478	Wire Assembly GRN 7".....	1
*	8220-067-001	Wire Assembly BLK/RED 7 3/4".....	1
*	8220-067-002	Wire Assembly BLK/BLU 7 3/4".....	1
*	8220-001-466	Wire Assembly Yellow 4 7/8".....	1
*	9627-711-001	Low Voltage Harness.....	1
*	9637-403-003	High Voltage Harness.....	1
*	8220-001-290	Wire Assembly BLK 20".....	1
*	9627-679-002	Wire Harness Heat Sensor.....	1

Label Group

Key	Part Number	Description	Qty
*	8507-256-001	Instructions Uncrating.....	1
*	8514-072-001	Owners Booklet.....	1
*	8507-350-001	Instructions Dry Install / Start-Up.....	1
*	8507-330-001	Instructions TVSS.....	1
*	9345-899-001	Wiring Schematic.....	1
*	9345-890-001	Wiring Diagram.....	1
*	8511-001-002	Label Quality.....	1
*	8502-658-001	Label Fire Hazard.....	1
*	8527-115-001	Label Decal Lighting and Clearance.....	1
*	8502-645-001	Label Instructions.....	1
*	8502-600-001	Label Warning and Notice.....	1

Rear Guard Group

Key	Part Number	Description	Qty
*	9208-067-001	Drive Guard.....	1
*	9454-685-001	Right Side Panel Drive Guard.....	1
*	9454-686-001	Left Side Panel Drive Guard.....	1
*	9550-175-001	Motor Shield.....	1
*	9545-008-003	Screw 10-16 x 1/2 TEK.....	2
*	9545-008-024	Screw 10 B x 1/4.....	24

Electric Heated Dryers Electrical Parts All Types of KW DCTD 80HC_16 FH 208/60/3 35 KW

Key	Part Number	Description	Quantity
*	5192-294-001	Relay - 125A.....	1
*	9377-003-001	Variator Coil Supply.....	1
*	5198-213-005	Circuit Breaker 3 Pole.....	2
*	8220-057-014	Wire Assembly Blk.....	3
*	9345-917-001	Schematic.....	1
*	9345-918-001	Diagram.....	1
*	9870-088-006	Heater Elements.....	2
*	5192-295-011	Relay.....	1
*	8502-711-001	Warning Label 208V.....	1
*	8220-057-004	Wire Brown 30".....	1
*	8220-057-007	Wire White/Black 45".....	1
*	8220-057-008	Wire Black 45".....	1
*	8220-057-011	Wire Violet 32".....	1
*	8220-057-015	Wire Black 8".....	6
*	8220-057-019	Wire White 8".....	1
*	8220-061-008	Wire Black 36".....	4
*	8220-061-010	Wire Black 48".....	2
*	8220-078-008	Wire Black 9".....	2
*	8220-078-011	Wire White 45".....	1
*	8220-078-012	Wire Red 45".....	1
*	8502-614-004	Label High Voltage.....	1
*	8502-708-001	Label Exhaust Warning.....	1
*	8514-092-001	Owners Book.....	1
*	9029-127-001	Guard Bracket Mounting.....	1
*	9208-053-001	Guard Front Cabinet Cover.....	1
*	9208-056-001	Guard Rear Cabinet Cover.....	1
*	9074-289-001	Cover Plate Control Box.....	1
*	9210-117-001	Gussett Control Box.....	1
*	9548-282-001	Support Wire.....	2
*	9074-288-001	Cover Plater Heater.....	1
*	9636-151-001	Wrapper Heat Housing LH.....	1
*	9636-152-001	Wrapper Heat Housing RH.....	1
*	9550-181-001	Shield Side Heathousing.....	2
*	9577-056-001	Top Heater Housing Half.....	2
*	9053-067-004	Bushing Insulated 1".....	6
*	9577-057-001	Top Box Control.....	1
*	9636-153-001	Wrapper Box Control.....	1
*	9058-025-001	Bottom Box Control.....	1
*	9053-067-004	Bottom Bushing Insulated.....	2
*	9295-004-001	Formed Jumper.....	2
*	9295-005-001	Straight Jumper.....	4
*	9488-010-003	Din Rail 4 3/4".....	1
*	9897-037-001	Power Block 3 Pole.....	1
*	9897-038-001	Power Block 1 Pole.....	1
*	9209-087-001	Grommet.....	1
*	8640-399-004	Nut Spring.....	1
*	8640-399-009	Nut Spring U Type.....	4
*	8502-639-001	Label Warning.....	1
*	8502-702-001	Label Warning Fire Hazard (French).....	1
*	8652-134-002	Terminal Lug Solderless.....	1

Electric Heated Parts Model Specific

DCTD 80H__ 16 FG 240/60/3 30 KW

Key	Part Number	Description	Quantity
*	5198-213-003	Circuit Breaker 3 Pole	2
*	5192-285-004	Relay	1
*	9870-088-002	Heater Elements	2
*	9345-965-001	Schematic	1
*	9345-966-001	Diagram	1
*	8220-057-014	Wire Black 8"	1
*	5192-294-001	Relay 125A	1

DCTD 80H__ 16 FE 208/60/3 30 KW

Key	Part Number	Description	Quantity
*	9345-963-001	Schematic	1
*	9345-964-001	Diagram	1
*	5198-213-004	Circuit Breaker 3 Pole	2
*	5192-285-004	Relay	1
*	5192-294-001	Relay 125 amp Resistive Contact	1
*	9870-088-001	Heater Elements	2
*	8220-057-014	Wire Black 8'	1

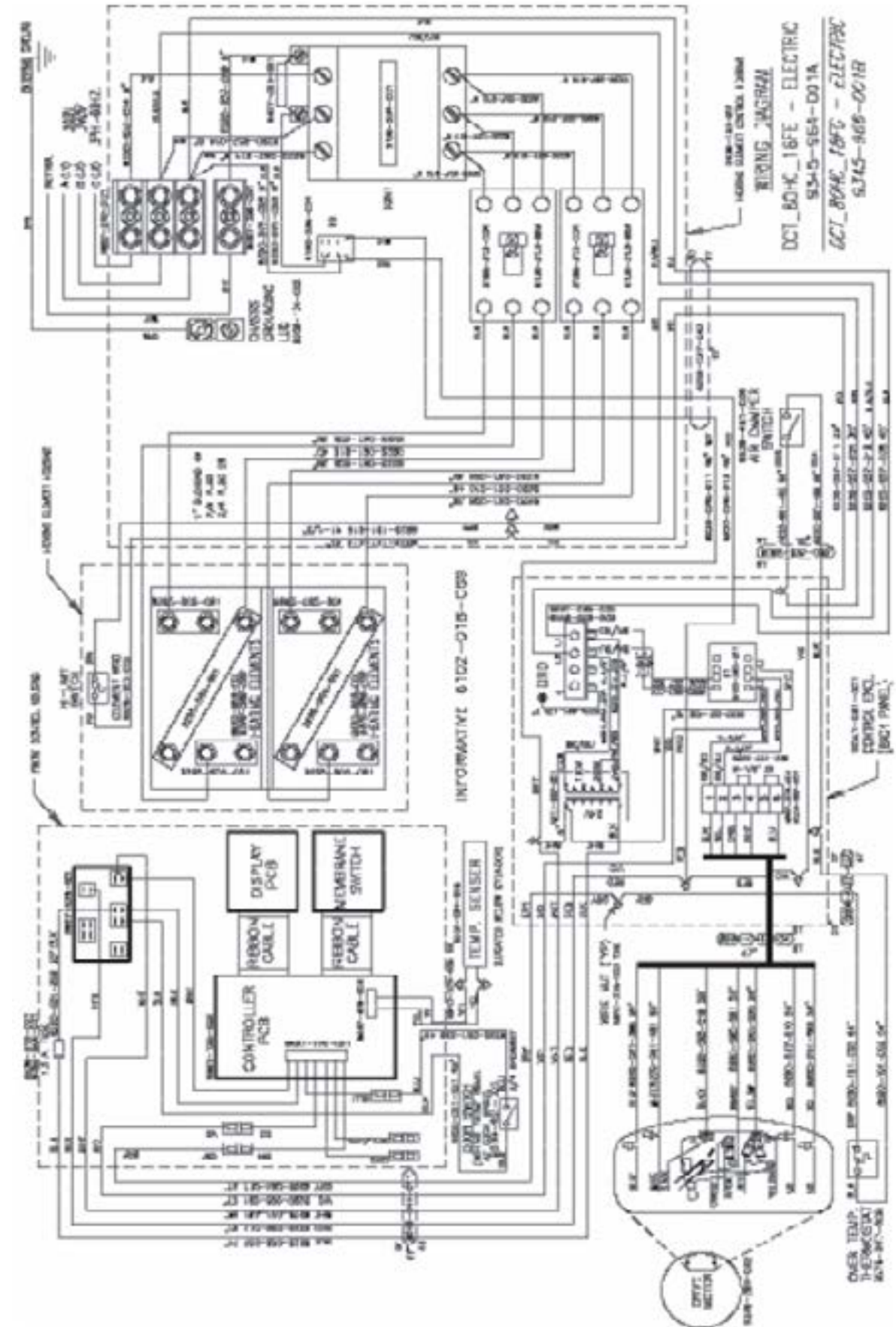

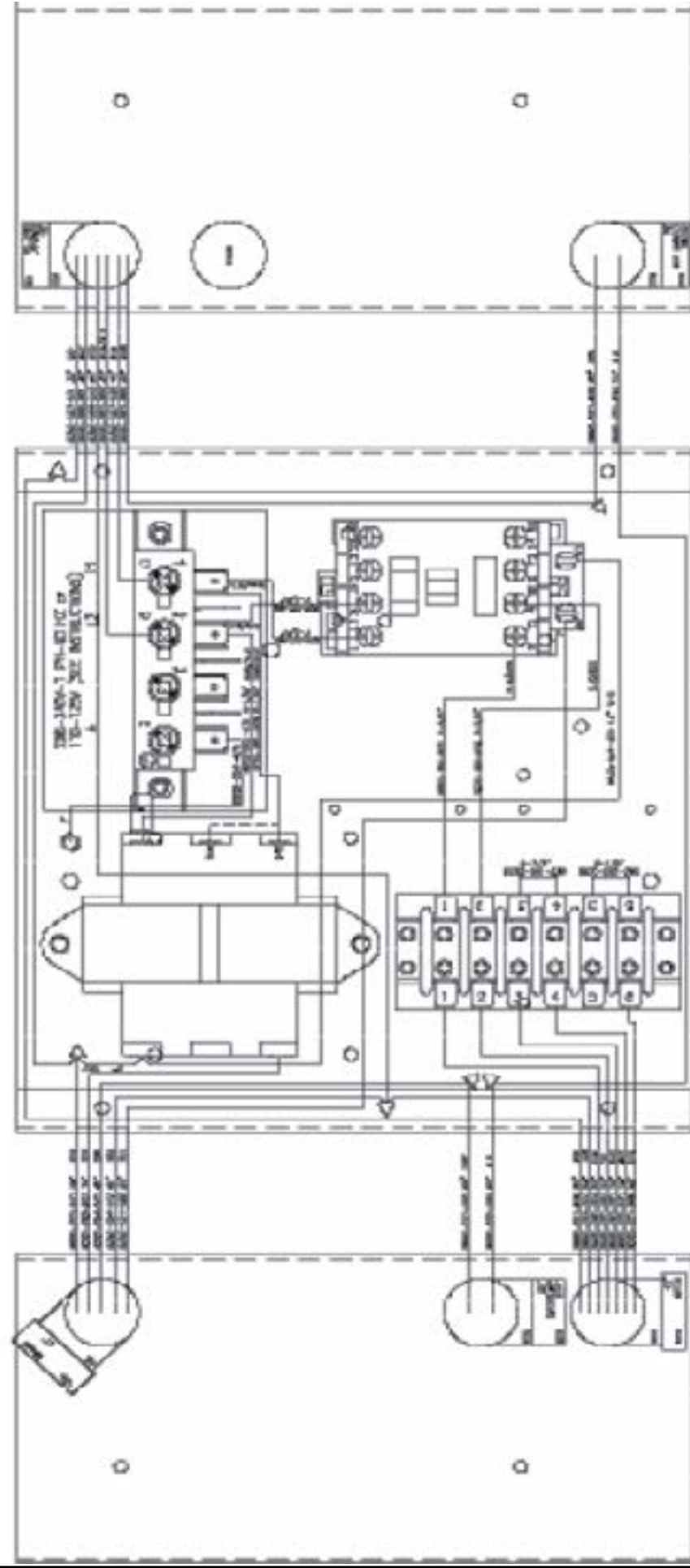

INFORMATIVE 6102-01B-079

9041-081-001J

SAMPLE BOX

DCT_80HC_1(6,8)F(E,G,H) - ELECTRIC

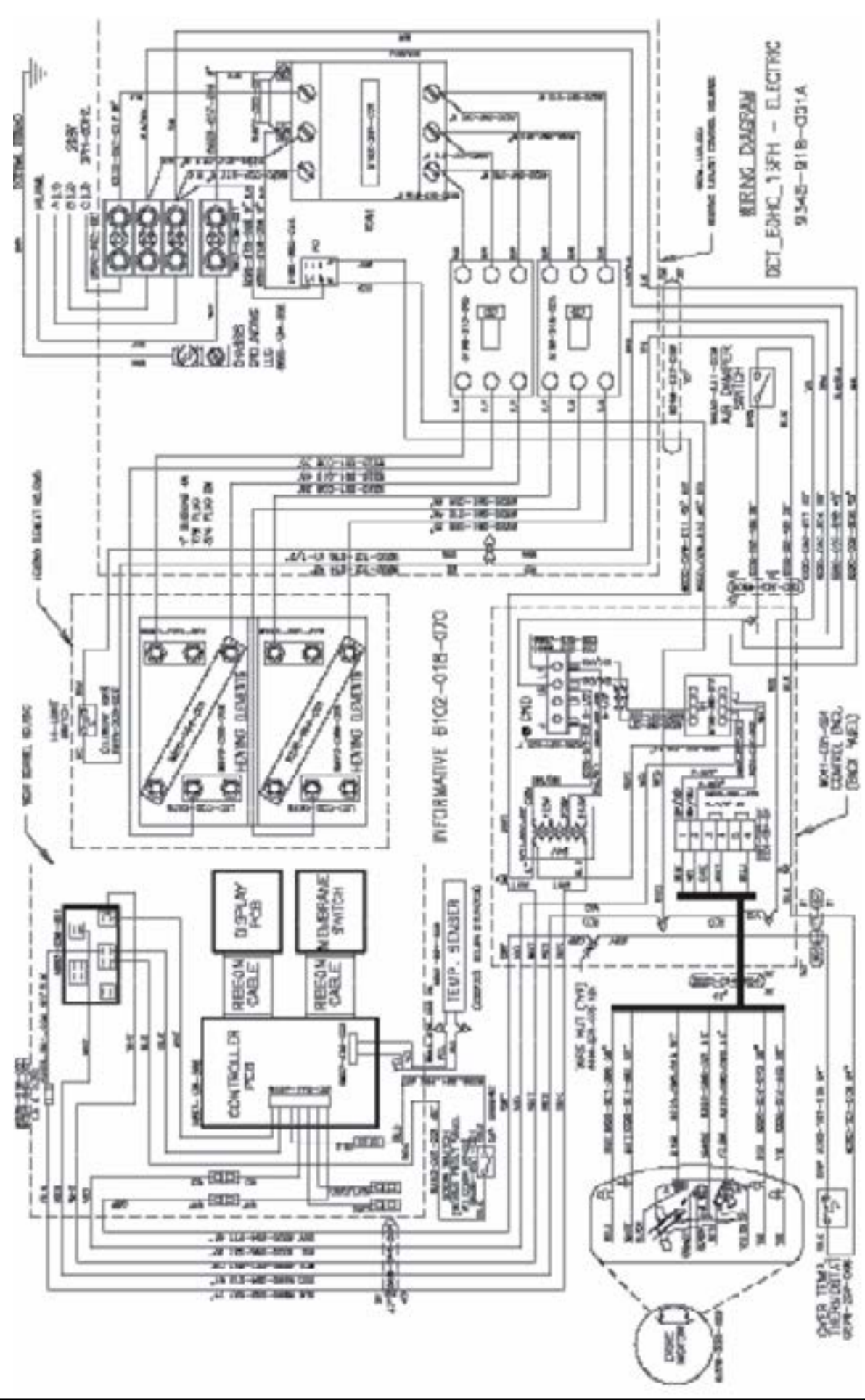

INFORMATIVE 6102-01B-070

DCT_80HC_1(6,8)F(E,G,H) - ELECTRIC
9345-91B-031A

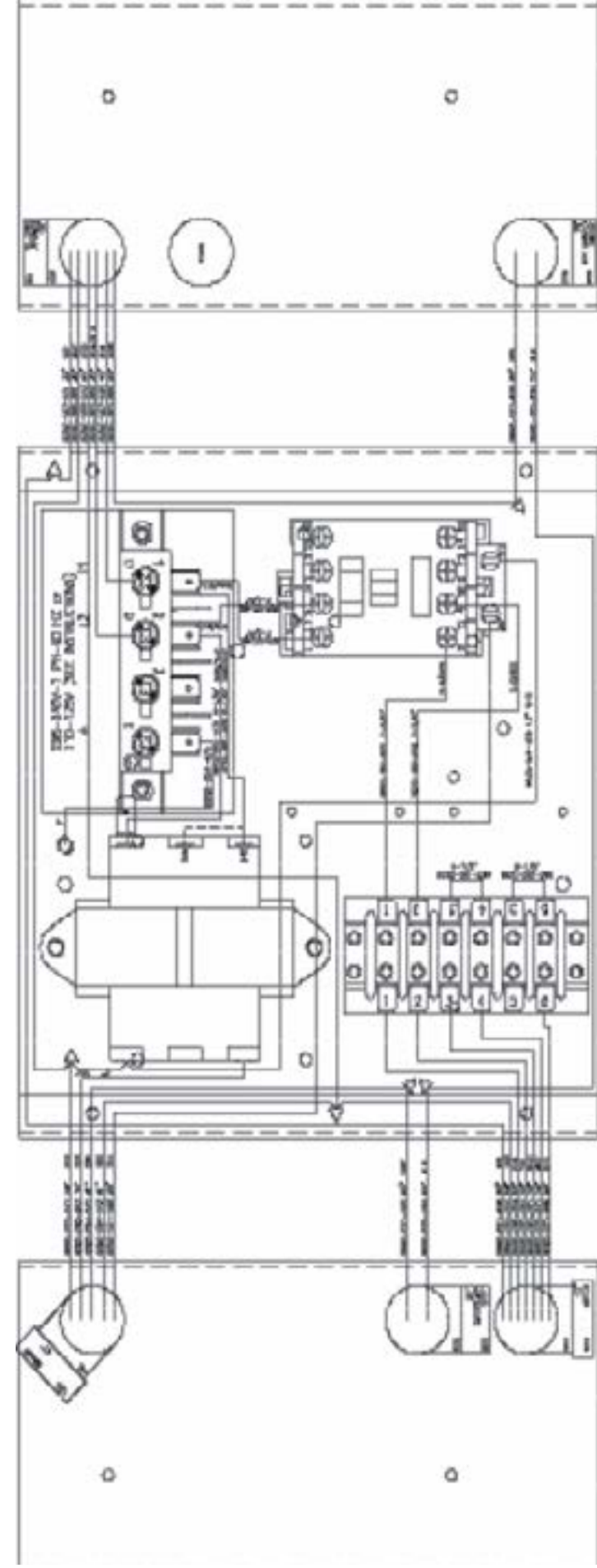

INFORMATIVE 6102-01B-079

9041-0B1-001J

SAMPLE_BOX

DCT_80HC_1(6,8)F(E,G,H) - ELECTRIC

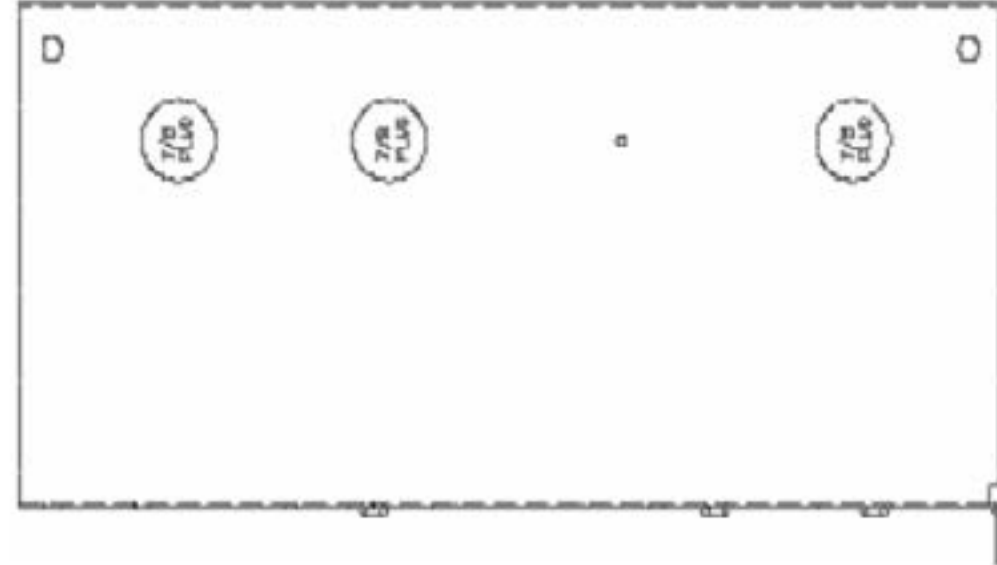

INFORMATIVE 6102-01B-080

9636-153-001B ELECTRIC_BOX

DCT_80HC_1(6,8)F(E,G) - ELECTRIC

DCT_80HC_18FH - ELECTRIC

Steam Heated Parts Model Specific

Key	Part Number	Description	Qty
*	9799-021-001	Steam PCB Assembly Micro	1
*	9805-031-001	Lint Screen Assembly Intake	1
*	9506-025-001	Wire Diagram For 10 FS Model	1
*	9506-026-001	Wire Schematic For 10 FS Model	1
*	9486-154-001	Retainer Lint Screen Intake	1
*	9488-012-001	Rail Lint Screen Intake	1
*	9379-193-002	Steam Valve Solenoid	1
*	9242-465-001	Braided Steam Hose Stainless	2
*	9181-031-001	Frame Lint Screen Intake	1
*	9089-049-001	Coil Steam Heating	1
*	8514-137-001	Owners Manual	1
*	8502-717-001	Label Lint Screen	1
*	8220-078-017	Wire Assembly White 7"	1
*	8220-078-016	Wire Assembly Red 7"	1
*	8220-075-015	Wire Assembly Black/Yellow 40"	1
*	8220-067-002	Wire Assembly Black/Blue 7 3/4"	2
*	8220-064-039	Wire Assembly White Yellow 40"	1
*	8220-064-037	Wire Assembly Green 40"	1
*	8220-063-010	Wire Assembly Black/Red 7"	1
*	5192-285-004	Relay (clear)	1
*	5192-295-011	Relay (large)	1
*	9506-027-001	Wire Schematic for 60FS Model	1
*	9506-028-001	Wire Diagram for 60FS Model	1
*	9506-029-001	Wire Schematic for 61FS Model	1
*	9506-030-001	Wire Diagram for 61FS Model	1

Steam Wire Diagram 240 Volt

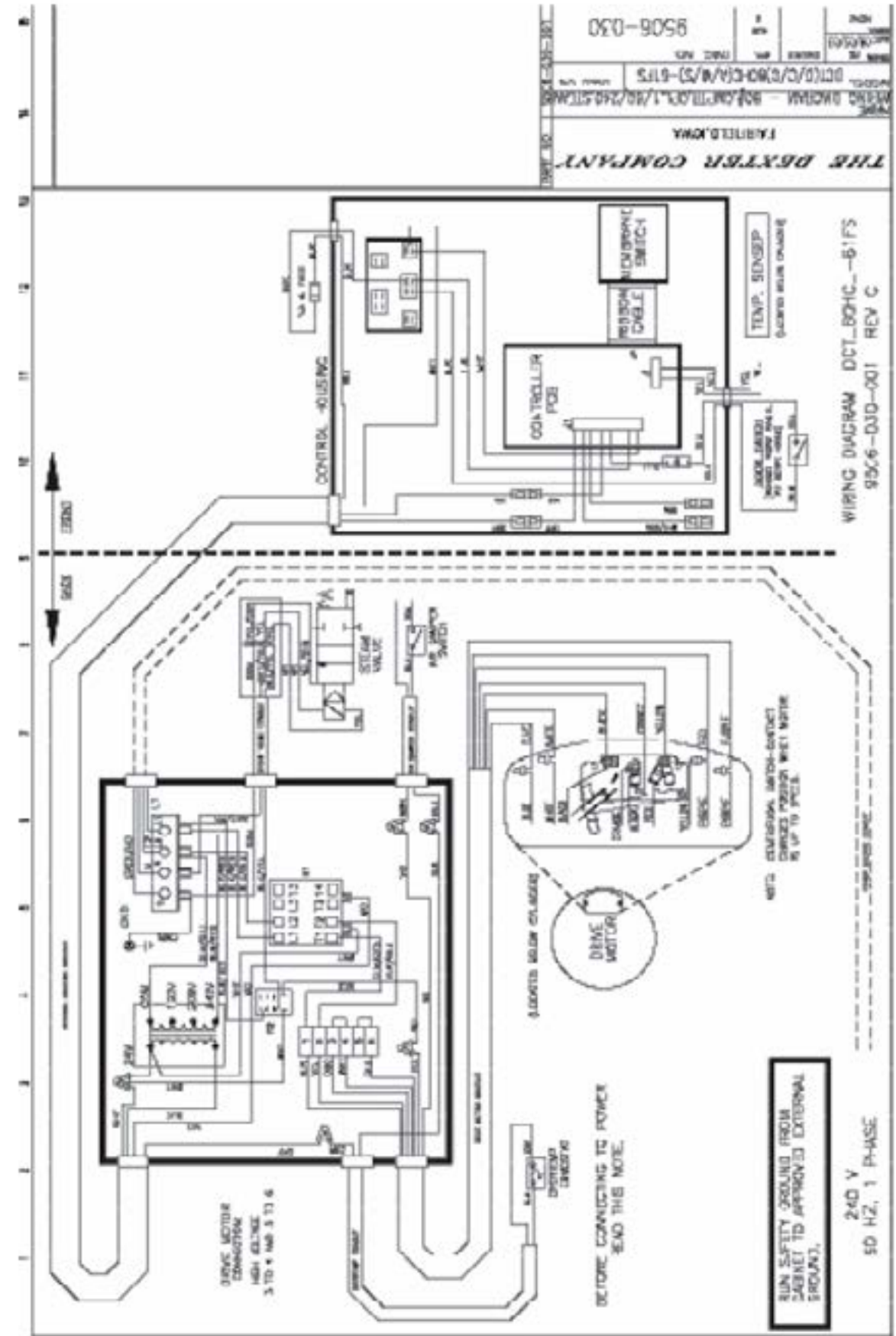

Steam Wire Diagram 120 Volt

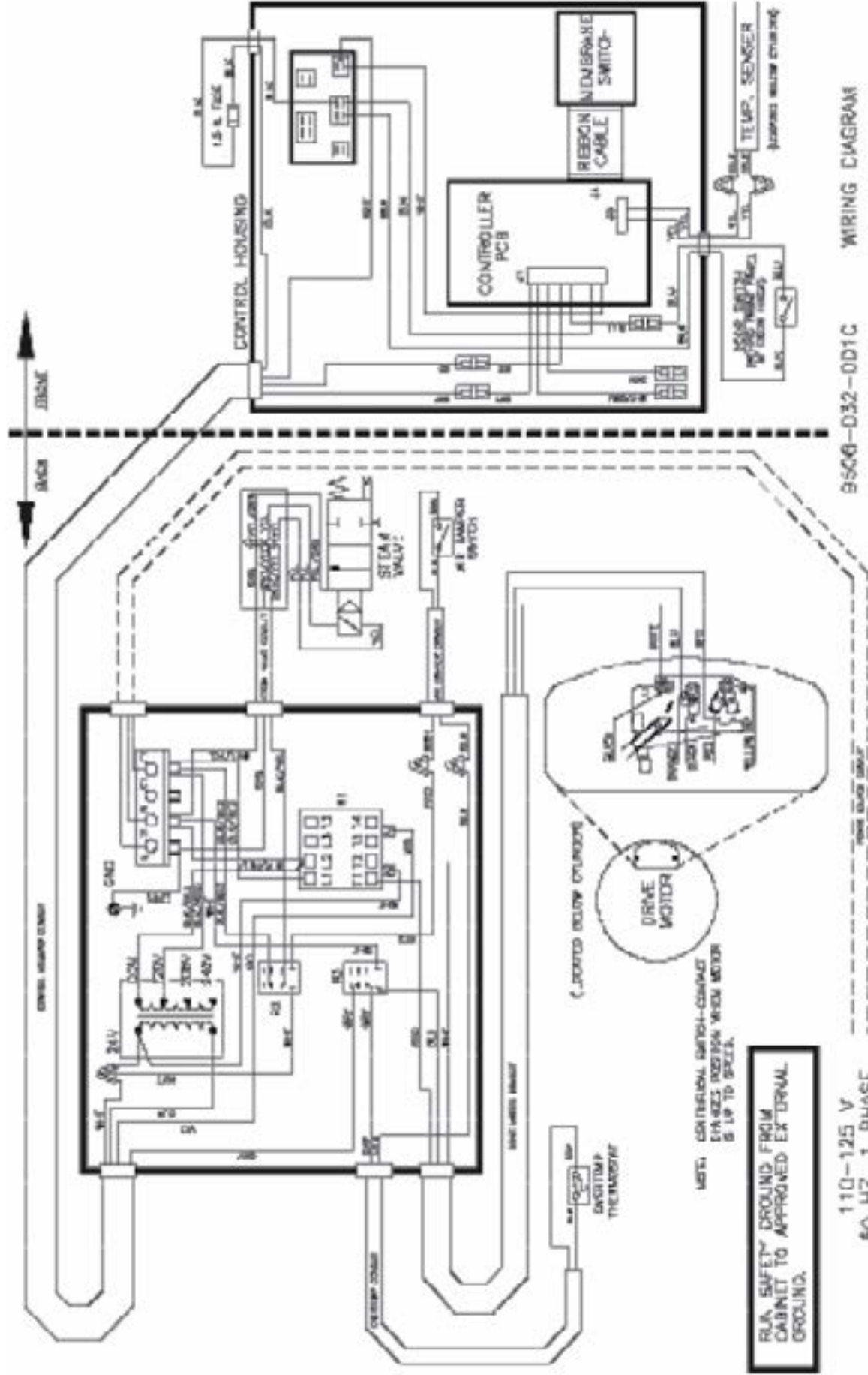

Steam Wire Informative

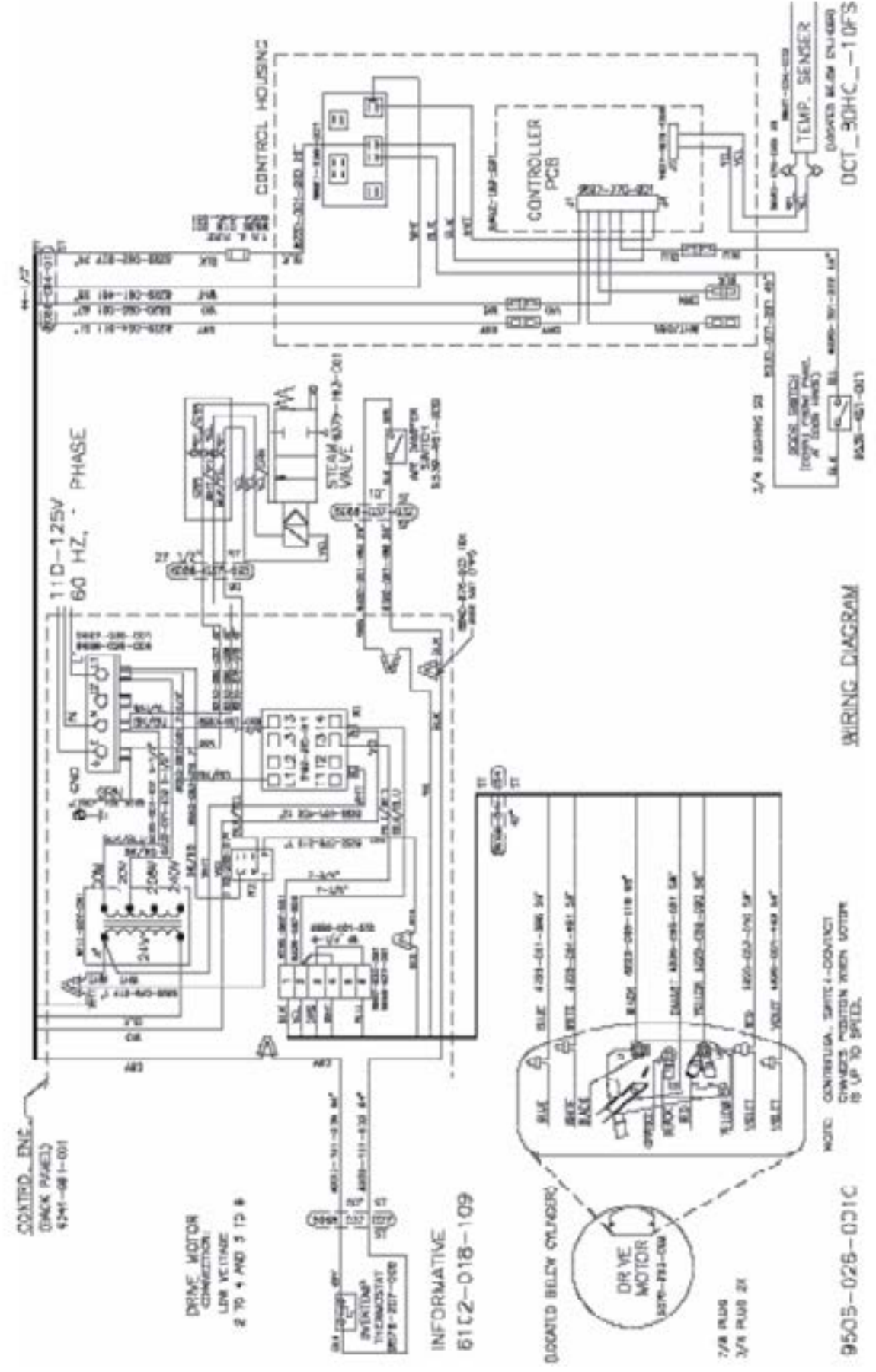

Steam Wire Diagram 208 Volt

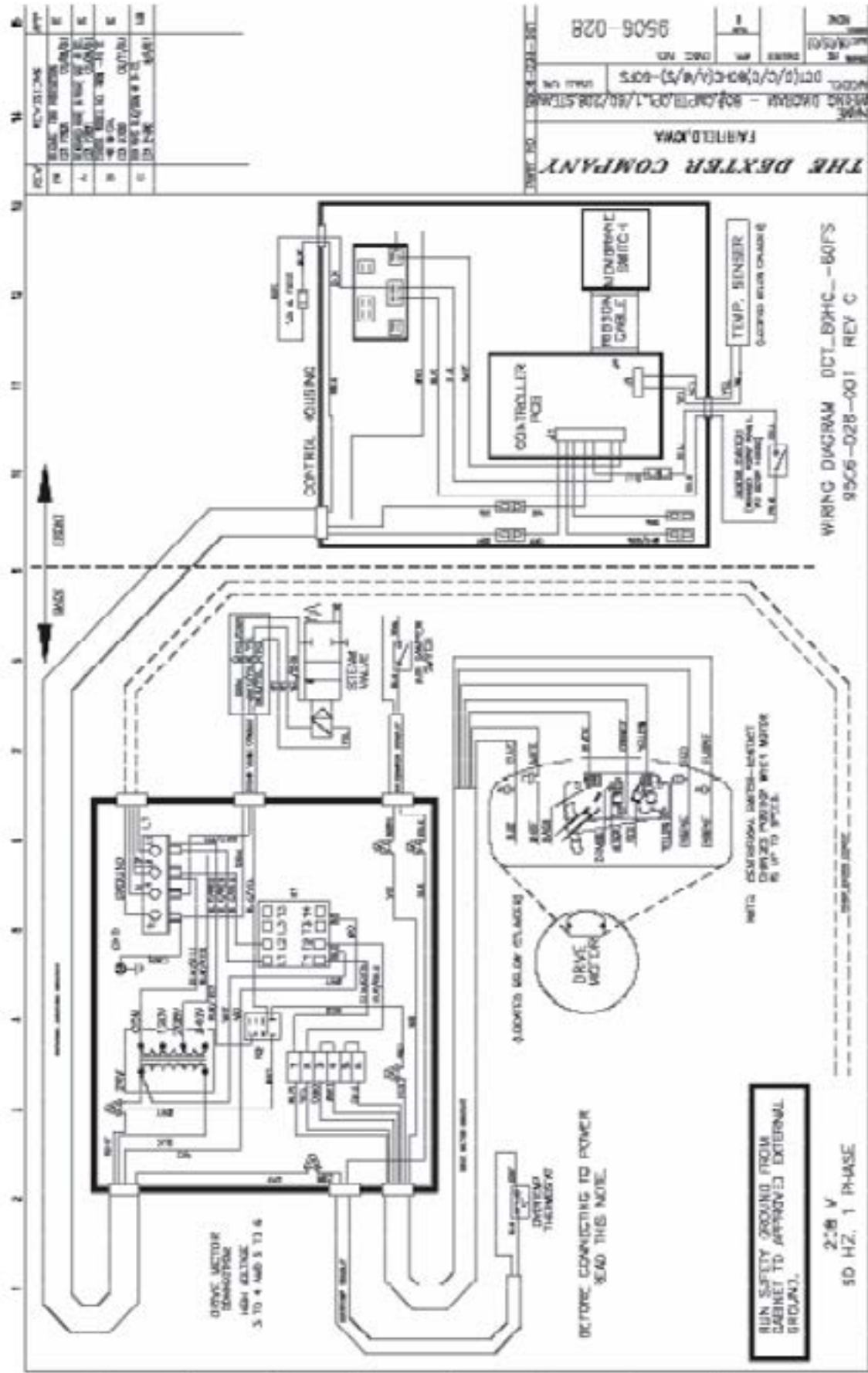

Section 7: Maintenance