



DEXTER[®]
LAUNDRY

**USE THE BLUE TABS LOCATED ON THE
RIGHT AND LEFT SIDES OF THE FOLLOWING
DOCUMENT TO ADVANCE TO EACH SECTION.**

Kits, Assemblies, & Common Parts

Coin Acceptor Components	Part Number
Mechanical Coin Acceptor	9021-002-016
Coin Drop Screws	9545-025-001
Loading Door Components	Part Number
Door Handle	9244-082-001
Door Close Switch	9539-461-001
Heating Circuit Components	Part Number
Ignition Control Module	9857-116-003
Ignition Electrode Assembly	9875-002-003
Thermostat, Hi-Limit	9576-203-002
Thermostat, Overtemp	9576-207-006
Fuseholder	9054-045-001
Fuse 1.5 amp	8636-018-001
Cabinet Components	Part Number
Cleanout Duct Assembly 8"	9973-034-001

Section 6:

Parts Data

N-Series Coin

Models
DRR55Q
DRC55Q

Cabinet Group by Part

Key	Part Number	Description	Qty
*	9960-256-021	Door Assy., Loading Complete-Wht	1
*	9960-256-025	Door Assy., Loading Complete-SS	1
*	9960-256-022	Door Ass'y, Loading Complete-ALM	1
1	9960-255-007	Door Assy., Loading-SS	1
2	9982-280-002	Plate Assy., Hinge (Wht)	1
2	9982-280-011	Plate Assy., Hinge (SST)	1
*	9545-012-015	Screw, Hinge to Door	4
*	8640-413-002	Nut, Hinge to Door	4
3	9212-002-003	Glass, Door	1
4	9206-164-009	Gasket, Glass	1
*	9548-117-000	Support, Door Glass	1
5	9206-420-001	Gasket, Outer Rim	1
6	9244-082-001	Handle, Loading Door	1
*	9545-018-017	Screw, Handle	2
*	9531-033-001	Stud, Door Catch	1
*	8640-413-001	Nut, Hex	1
*	9086-015-002	Catch, Loading Door	1
7	9454-694-008	Panel Assy., Front- white	1
7	9454-694-003	Panel Assy., Front- S. Steel	1
7	9454-694-011	Panel Ass'y, Front-almound (computer only)	1
*	9454-694-010	Panel Ass'y, Front-almound (rotary only)	1
8	9108-102-007	Door, Upper Service-almound	1
8	9108-102-004	Door, Upper Service-White	1
8	9108-102-001	Door, Upper Service-SS-	1
9	9578-091-002	Trim, Door-Upper Service	1
10	8650-006-003	Lock, Upper Service	1
*	8638-211-001	Rivet, Drive	2
*	8641-581-005	Washer, Flat	2
*	9548-243-002	Support, Upper Door	1
*	6292-006-006	KEY - Only Service Lock	1
11	9412-083-001	Nameplate, Commercial Dryer ROTARY	1
11a	9412-083-002	Nameplate, Commercial Dryer COMPUTER	1
12	9545-012-003	Screw, Chrome	4
*	8641-436-000	Washer, Fiber	4
*	8641-582-019	Lockwasher	10
*	8640-399-001	Nut, Spring	6
13	9544-047-002	Strap, Hinge (White)	1
13	9544-047-007	Strap, Hinge (Gray)	1
*	9545-008-009	Screw, Hinge to Panel	4
14	9545-052-001	Screw, Door to Hinge Strap	1
*	8641-436-004	Washer, Fiber	1
15	9960-262-004	Door Ass'y, Lower Service-Almond	1
15	9960-262-003	Door Ass'y, Lower Service-White	1
15	9960-262-001	Door, Ass'y Lower Service--SS	1
16	9578-088-002	Trim, Door - Lower Service	1
17	9545-008-021	Screw, Pn Hd Cr., #10x3/8	4
18	9578-088-002	Trim, Kick- Lower Service Door	1
19	9545-008-010	Screw, Tr Hd Cr-#10x1/2 Blk	4
20	8650-006-003	Latch, Lower Door Lock & Key	1

* Not Illustrated

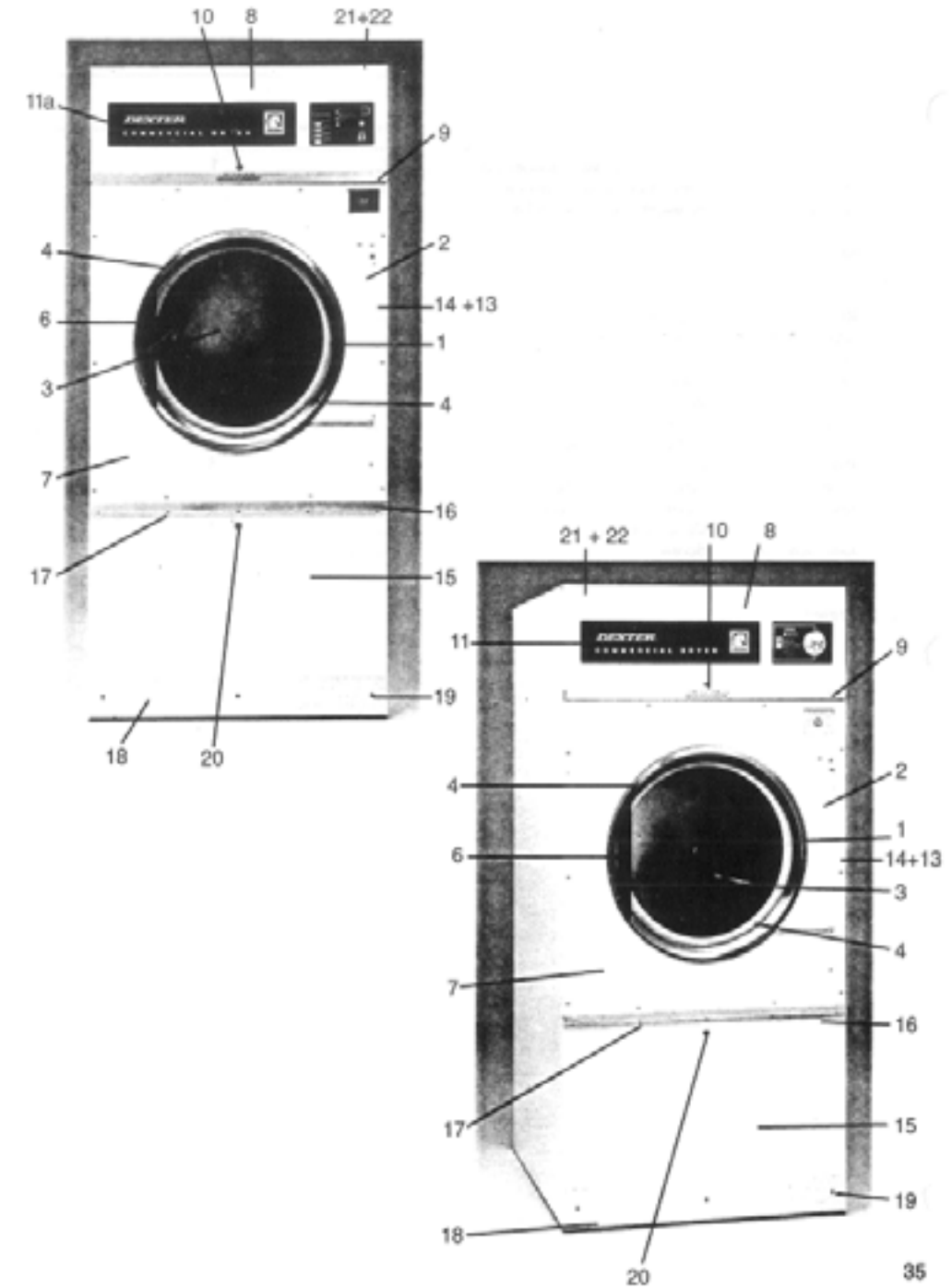

Key	Part Number	Description	Qty
*	8544-005-000	Leg, Leveling	4
*	9208-051-001	Guard Drive	1
*	9454-688-002	Panel, Side guard (L.H.)	1
*	9454-688-001	Panel, Side Guard (R.H.)	1
*	9550-175-001	Shield, Motor	1
*	9812-012-001	Baffle, Cabinet-Left	1
*	9812-012-002	Baffle, Cabinet-Right	1
*	9545-008-003	Screw, #10x1/2	8
*	8658-012-000	Box, Electric Junction	1
*	8643-005-000	Cover, Electric Junction Box	1
21	9074-276-001	Cover, Cabinet	1
22	9545-008-024	Screw	10

Control Housing Group Computer Only

Key	Part Number	Description	Qty
1	9471-010-001	Electronic Control	1
2	9538-157-003	Spacers, Circuit Board	6
3	8640-276-003	Nut, Circuit Board	6
4	8641-582-009	Lockwasher, Circuit Board	6
5	9627-651-001	Harness, Wiring (Electronic Control)	1
6	9801-058-005	Switch, Ass'y Membrane	1
8	9982-281-004	Plate Ass'y Electronic Control	1
9	9545-008-008	Screw Plate Ass'y Mtg. (bottom)	2
*	9545-045-001	Screw, Mtg. (top)	1
*	8502-640-002	Label, Control Instruction/ Warning	1
*	9051-021-000	Bumper	2
14	9940-013-001	Chute Ass'y Coin	1
*	9545-008-008	Screw	4
*	9897-026-001	Terminal Block	1
*	9545-031-004	Screw Terminal Block Mtg	2
19	9021-002-016	Coin Acceptor Complete (includes #20)	1
20	9732-126-001	Switch, Coin	1
21	9063-004-001	Bail, Coin Return	1
22	9545-025-001	Screw, Acceptor Mtg	2
23	8641-573-012	Lockwasher	2

* Not Illustrated

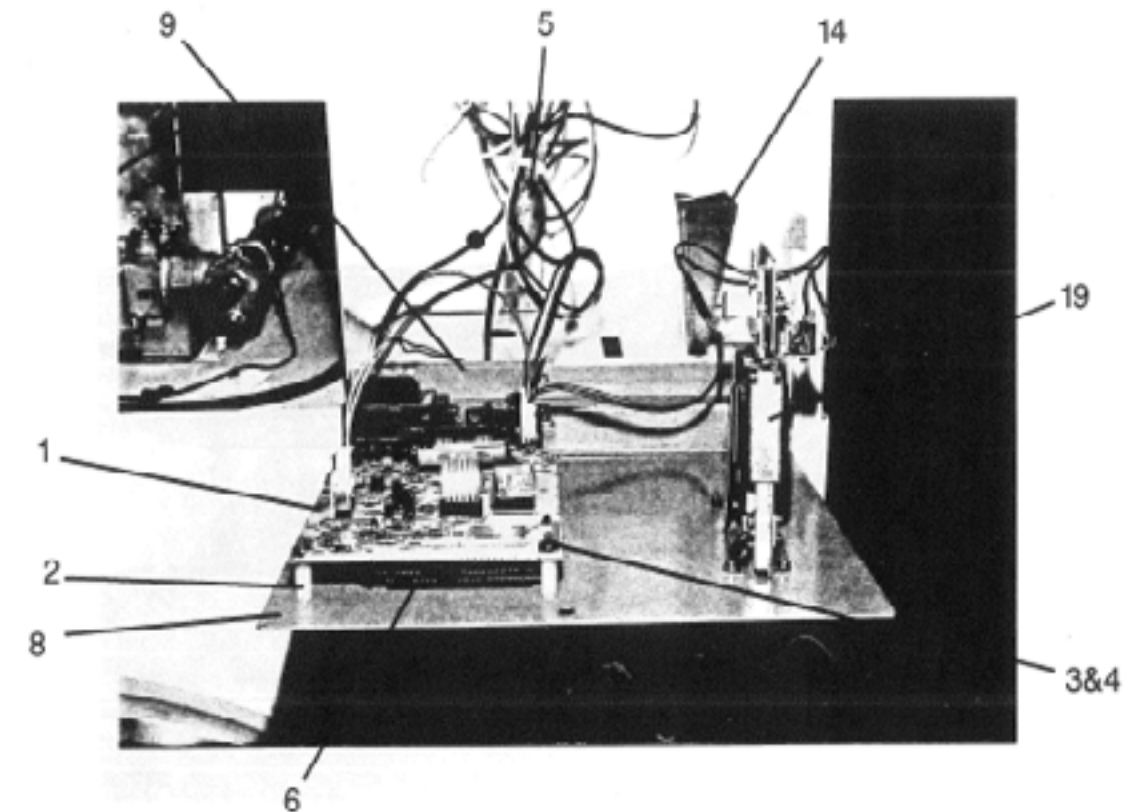
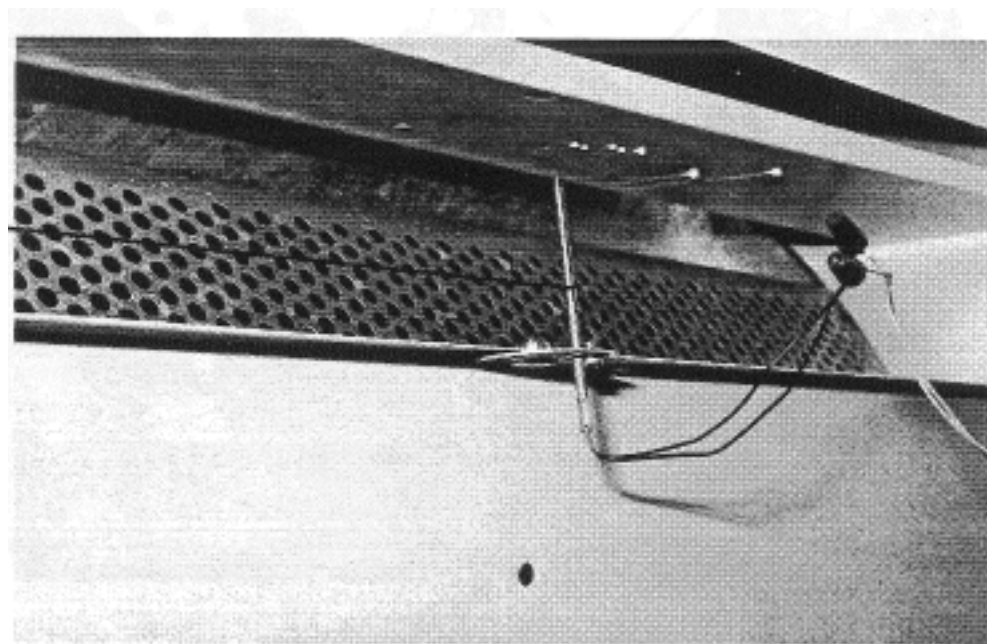
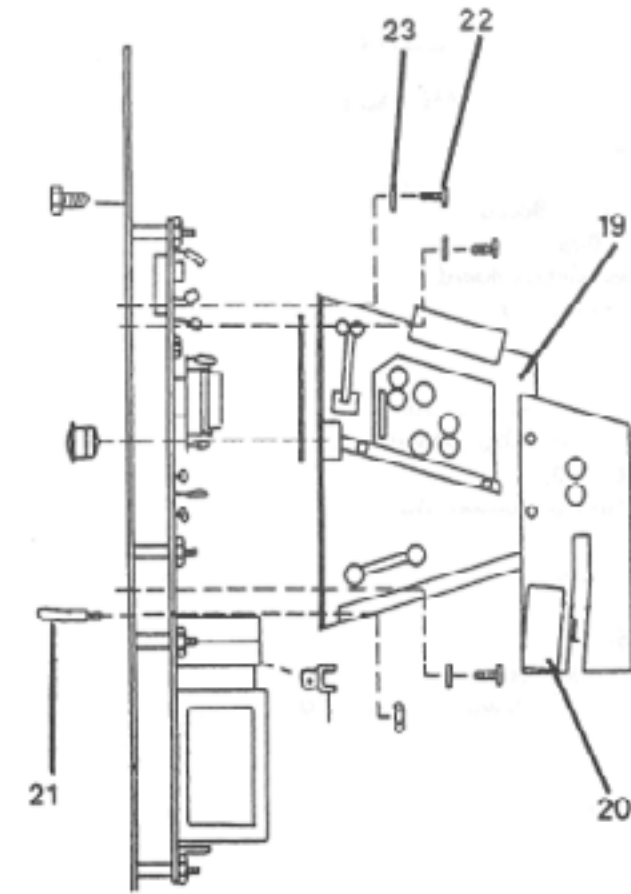

Control Housing Group Rotary Meter Only

Key	Part Number	Description	Qty
1	9944-038-029	Meter Ass'y Coin	1
2	9376-212-001	Aotor	1
3	9539-444-002	Switch, Cool Down (B)	1
4	9539-444-001	Switch, Motor Start (A)	1
5	9940-015-001	Chute Ass'y Coin	1
6	8641-581-006	Washer, Flat (meter assy. mtg.)	2
7	8641-582-019	lockwasher(meter assy. mtg.)	2
8	8640-413-002	Nut (meter assy. mtg.)	2
9	9982-304-002	Plate, Meter Mtg	1
*	9095-032-006	Cam, Timing(4 pin)	
*	9095-032-007	Cam, Timing (5pin)	
*	9095-032-002	Cam, Timing (6 pin)	
*	9095-032-011	Cam, Timing (7 pin)	
*	9095-032-001	Cam, Timing (8 pin)	
*	9095-032-003	Cam, Timing (9 pin)	
*	9095-032-004	Cam, Timing (10 pin)	
*	9095-032-012	Cam, Timing (11 pin)	
*	9095-032-005	Cam, Timing (12 pin)	
11	9451-146-005	Pin Hinge	1
12	9539-460-001	Switch, Push to start	1
13	9576-209-002	Thermostat with probe	1
14	9545-044-004	Screw, thermostat mtg.6-32x1/4"	2
15	9545-045-001	Screw, Bracket 8Bx1/4"	2
16	9348-056-003	Lever, Thermostat	1
18	9545-010-008	Screw, Thermostat knob	1
19	9897-026-001	Terminal block	1
20	9545-031-004	Screw, Terminal block mtg	1
21	9053-067-001	Bushing, door switch wires	1

* Not Illustrated

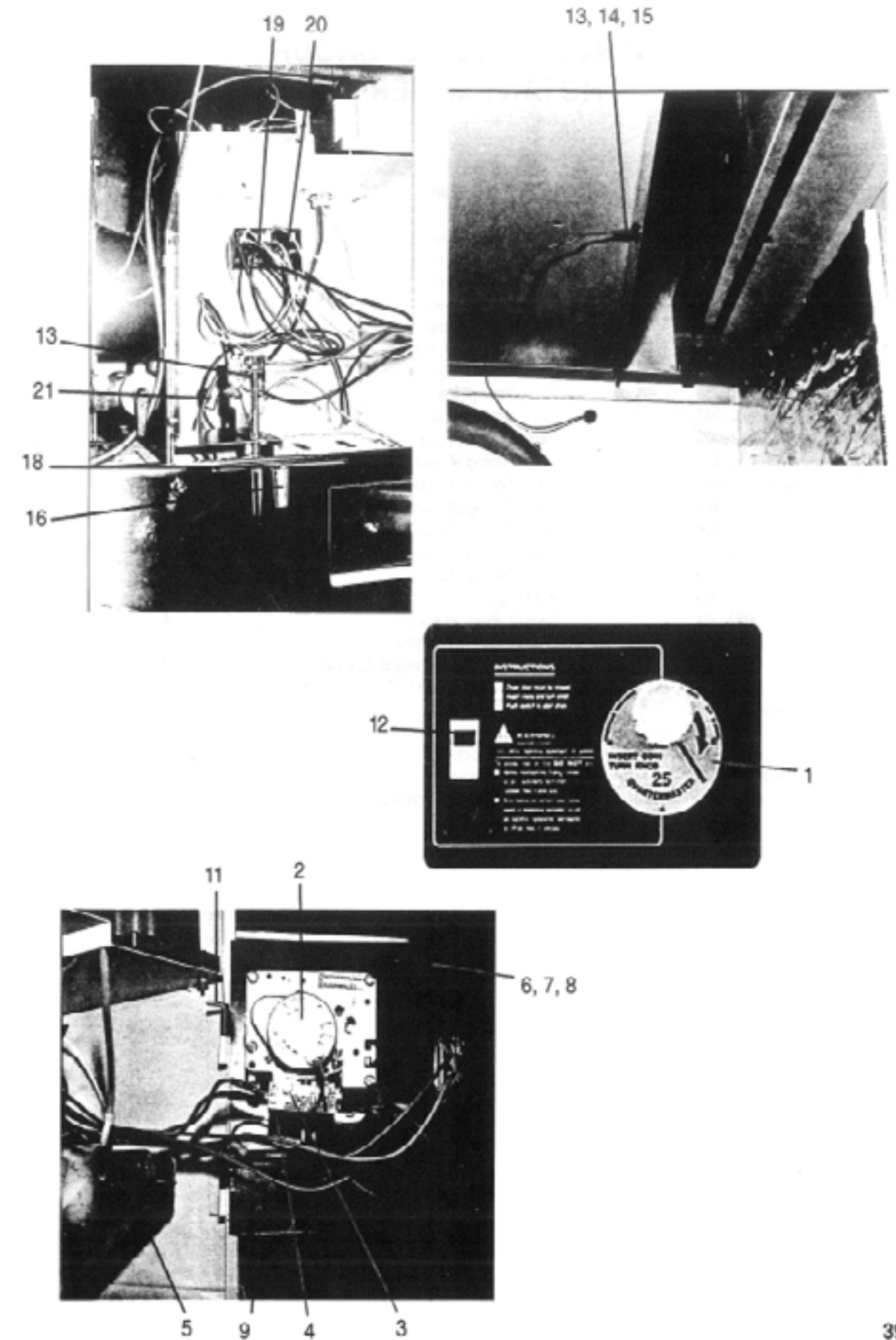

Drive Group by Part

Key	Part Number	Description	Qty
1	9376-300-001	Motor, Drive.	1
*	9545-014-004	Screw, Hx 5/16	4
*	8640-400-003	Nut.	4
2	9453-169-010	Pulley, Motor	1
*	9545-028-013	Screw, Set.	2
3	9991-054-004	Support Ass'y, Motor	1
4	9545-029-005	Screw	4
4	8640-415-004	Nut	4
*	9278-038-004	Impeller	1
*	9074-277-001	Cover, Impeller	1
*	9545-008-001	Screw, Hx #10x1/4	4
5	9991-053-001	Support Assy, Intermed. Pulley	1
6	9545-029-010	Bolt, Rd Hd	3
7	9545-029-003	Screw	1
8	8640-415-004	Nut	3
*	8641-581-035	Washer, Flat	4
*	9861-024-003	Arm Assy Tension Complete Front Serial Number #124816	1
9	9861-024-001	Arm Assy-Tension, Complete	1
*	8641-581-035	Washer, Flat	6
*	9487-200-003	Ring-Retaining	2
*	9908-042-006	Pulley Assy Intermediate Use After Serial Number #124816	1
10	9908-042-003	Pulley Assy, Intermediate	1
*	9036-159-007	Bearing, Ball-Idler Pulley	2
*	9538-173-001	Spacer, Bearing	1
*	8641-581-035	Washer, Flat	6
*	9487-200-003	Ring, Retaining	2
11	9908-043-002	Pulley Driven	1
*	9487-234-001	Ring, Tolerance	1
12	8641-581-026	Washer, Flat	1
*	8641-582-016	Lockwasher	1
13	9545-017-009	Screw, Hx Cap	1
14	9040-077-005	Belt, Final Drive	1
15	9040-077-003	Belt, Motor Drive	1
16	9534-151-000	Spring, Belt Tension	1
17	9099-012-002	Chain, Spring Tension	1
18	9248-022-001	Hook, Tension	1
*	9208-051-001	Guard, Drive	1
*	9454-688-001	Panel, Drive Guard, RH	1
*	9454-688-002	Panel, Drive Guard, LH	1
*	9550-175-001	Shield, Motor	1
*	9545-008-003	Screw	2
*	9545-008-024	Screw	32

*Not illustrated

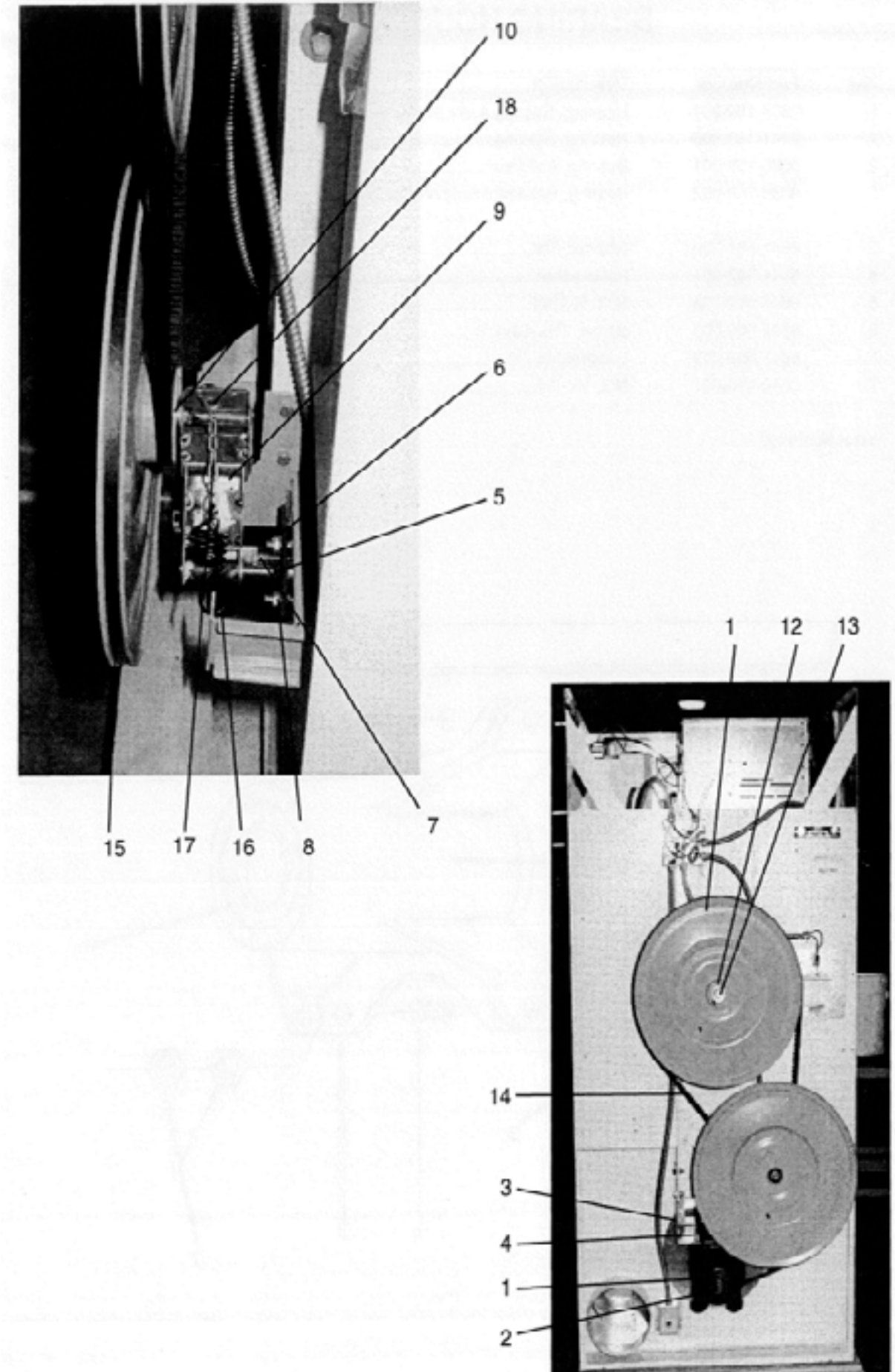

Door Switch Group by Part

Key	Part Number	Description	Qty
1	9041-076-001	Box, Door Switch	1
2	9550-159-001	Shield, Poor Switch	1
3	9539-461-001	Switch, Door	1
4	8640-401-001	Nut, Special Twin	1
5	9545-020-001	Screw, Pn Hd Sl.#4-40 x 3/4	2
6	9074-255-001	Cover, Switch Box	1
7	9545-008-020	Screw, Box Cover	2
8	9008-004-001	Actuator, Switch- Lower	1
9	6068-041-001	Conduit.	1
10	9545-012-003	Screw	2
*	8641-436-000	Washer, Fiber	1
11	8640-413-004	Nut, Elastic Stop	2

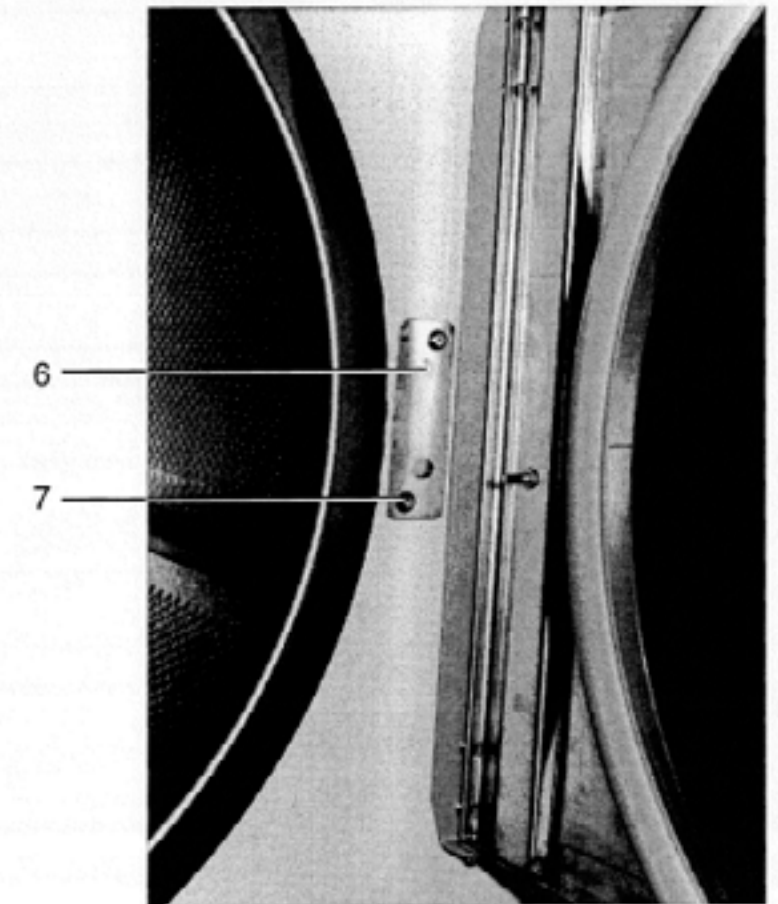
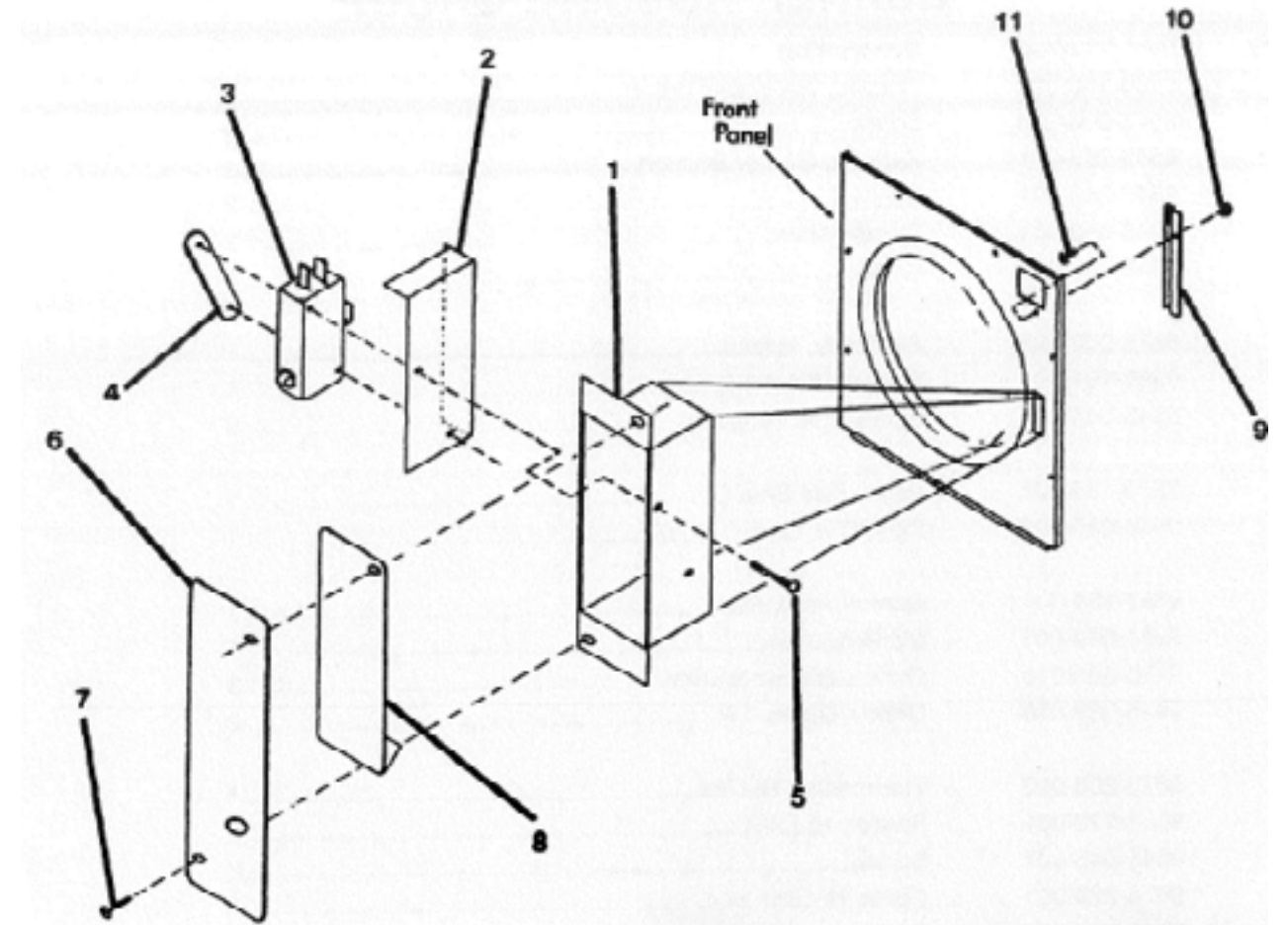

Burner Housing Group by Part

Key	Part Number	Description	Qty
1	9803-163-003	Housing Assembly, Burner	1
*	9545-008-024	Screw	4
*	9548-256-001	Support, Burner	1
*	9545-045-001	Screw	2
2	9048-018-001	Burner, Main	2
*	9545-045-001	Screw	4
3	9875-002-002	Electrode, Ignition	1
4	9985-161-001	Bracket, Electrode Mtg	1
*	9545-045-001	Screw, Electrode Mtg	2
5	9379-164-001	Valve, Gas Shut Off	1
*	9458-020-003	Pipe, Gas Line	1
6	9857-134-001	Control Assy, Gas	1
7	9381-009-001	Manifold, Assy	1
*	9425-069-015	Orifice, Burner-Natural	2
8	9576-203-002	Thermostat, Hi-Limit	1
*	9538-142-001	Spacer, Hi-Limit	2
*	9545-045-007	Screw	2
9	9074-234-001	Cover, Hi-Limit Stat	1
*	9545-008-024	Screw	1
10	9857-116-002	Control, Ignition	1
*	9545-044-002	Screw	2
*	8640-411-003	Nut, Hex Keps	2
11	9897-026-001	Terminal Block	1
*	9545-031-004	Screw	2
12	9631-403-003	Wire Assy, High Voltage	1
*	9627-711-001	Harness, Low Voltage Ignition	1
13	9054-045-001	Fuseholder	1
14	8636-018-001	Fuse	1
15	8711-002-001	Transformer, Control.	1
*	9545-008-026	Screw, #10 x 3/8	2
*	9732-102-005	Kit, LP Conversion	1

* Not Illustrated

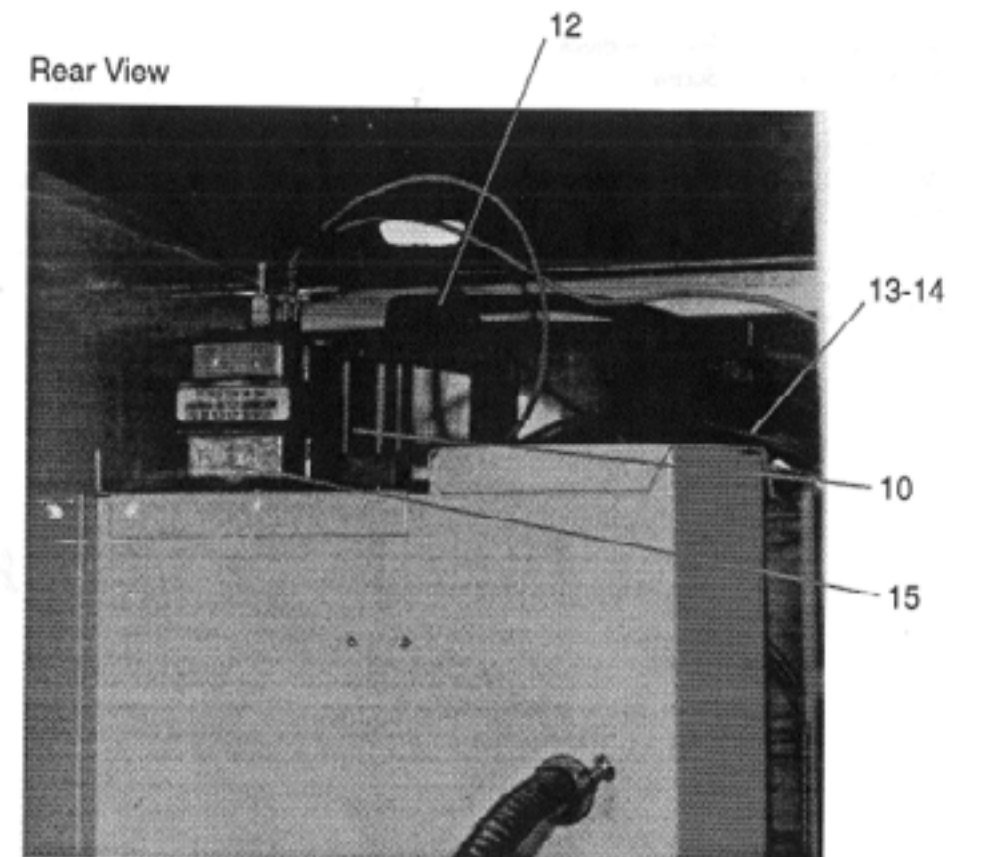
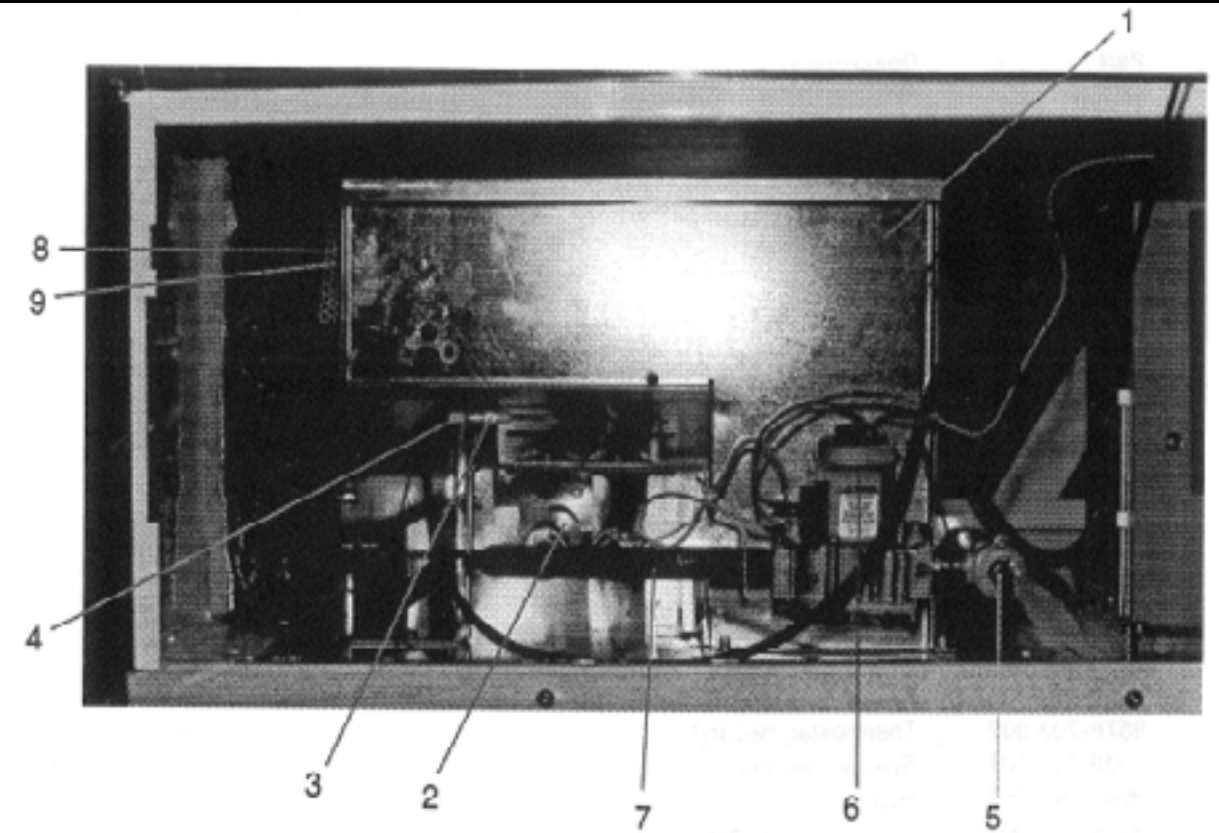

Bearing Housing Group by Part

Key	Part Number	Description	Qty
*	9803-189-001	Housing, Bearing Ass'y (includes #1 and #2)	1
1	9241-183-003	Housing, Bearing	1
2	9036-159-001	Bearing, Ball-Rear	1
*	9036-159-002	Bearing, Ball-Front Sold on Spider	1
3	8641-581-026	Washer, Flat.	4
4	8641-582-004	Lockwasher	4
5	9545-017-004	Bolt, 1/2-13x1	4
6	9545-059-003	Screw, 7 1/16 -14x1 1/2	2
*	8641-582-013	Lockwasher, 7 1/6	2
7	8640-416-001	Nut, 7/16 - 14	4

* Not Illustrated

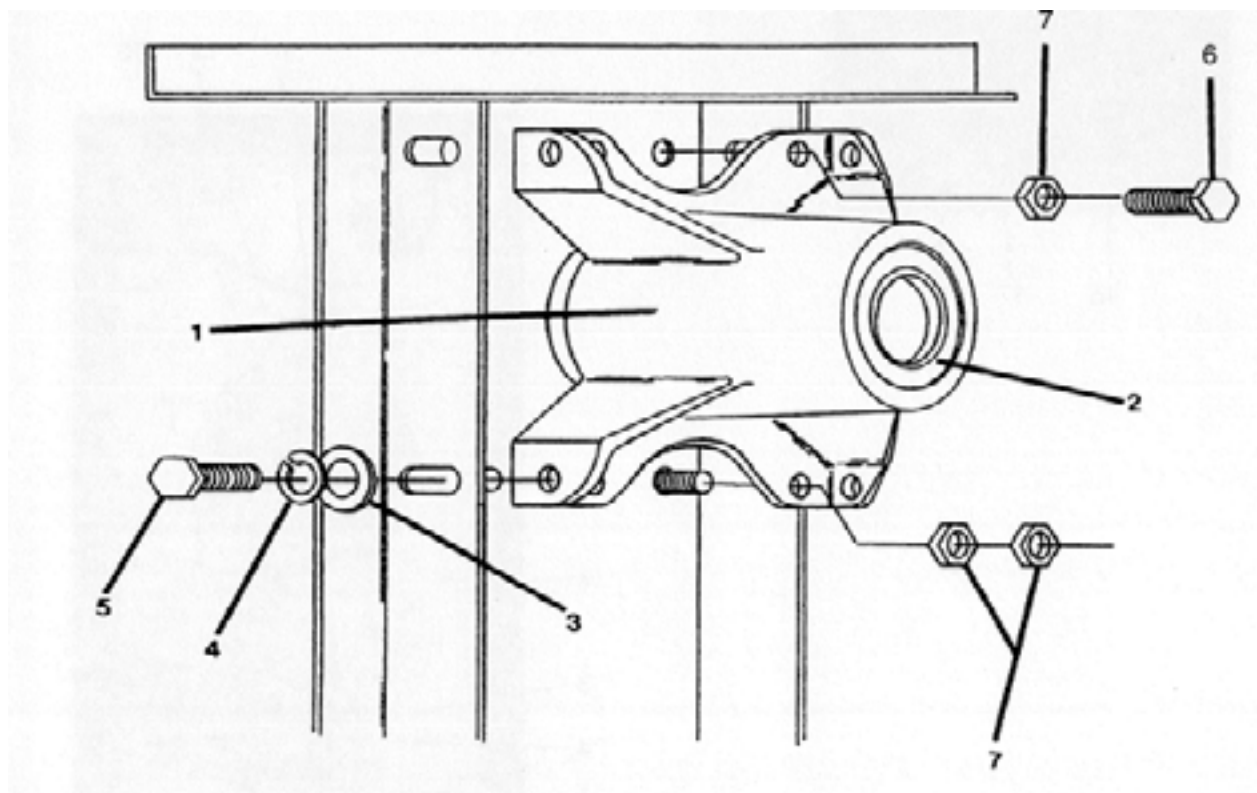

Tumbler Group by Part

Key	Part Number	Description	Qty
1	9848-119-001	Tumbler Ass'y.	1
2	9568-010-001	Spider Ass'y	1
3	9497-226-001	Rod, Tumbler	4
4	8640-417-002	Nut	4
5	9552-013-000	Shim	4
6	8641-582-004	Washer, Spring Lock	4
7.	8641-587-001	Washer, Tumbler Rod Special	4
*	9487-234-001	Ring, Tolerance	1
8	8641-582-016	Lock Washer, Tumbler Shaft	1
9	8641-581-026	Flat Washer, Tumbler Shaft	1
10	9545-017-009	Screw, Tumbler Shaft.	1

* Not Illustrated

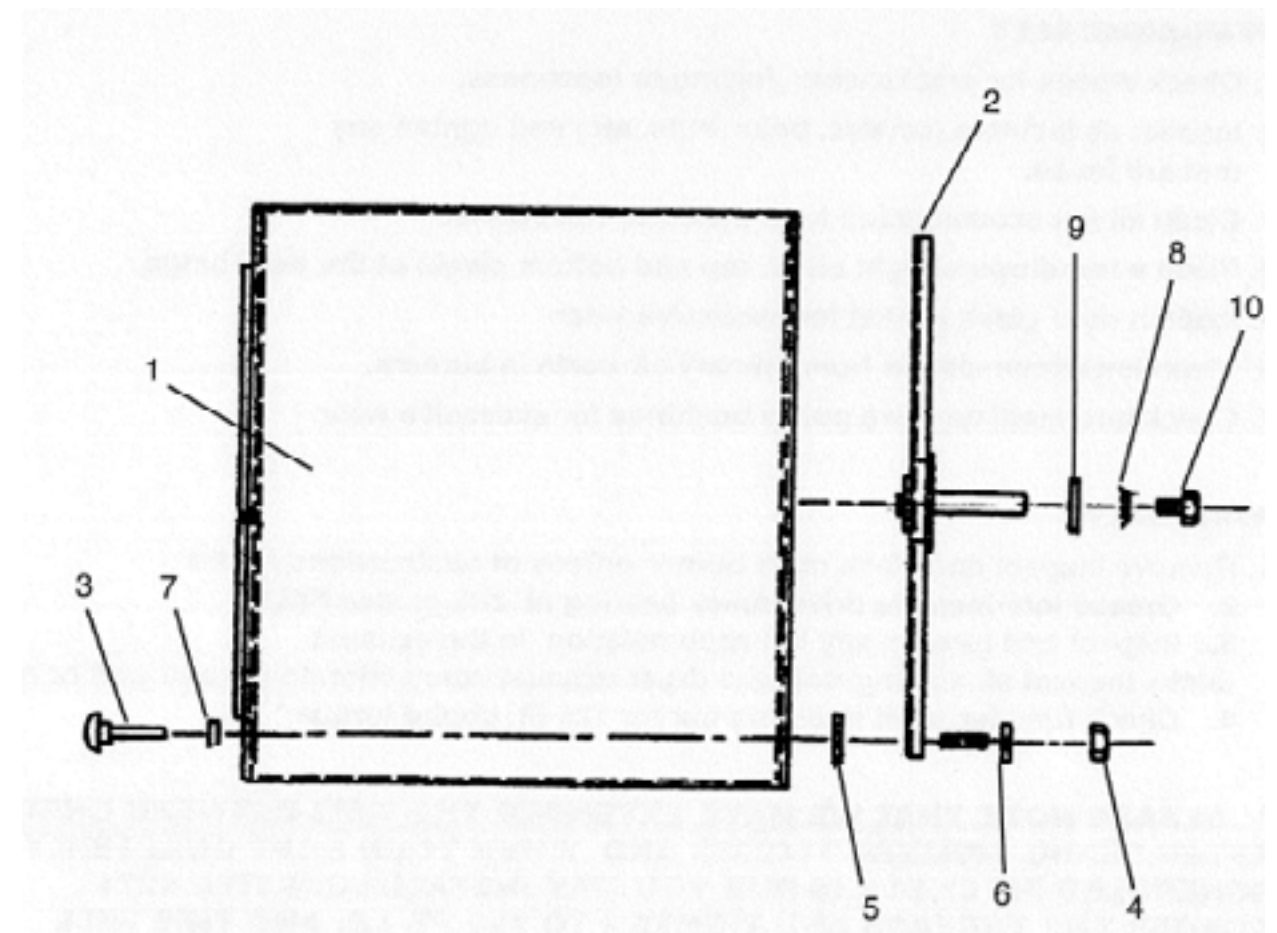

Damper Switch, Lint Hood, & Blower Impeller Group Style No. 1 (in use since 1998)

Key	Part Number	Description	Qty
1	9539-432-001	Switch, Damper	1
*	9545-044-002	Screw, Hx #6-32x1	1
*	8640-411-003	Nut, Hex #8-32	1
*	9545-044-002	Screw, Hx 6-32x1	2
*	8640-420-001	Nut, Speed Tandem	1
2	9125-001-001	Damper	1
3	9451-146-001	Pin, Damper Hinge	1
4	9074-242-002	Cover, Damper Switch	1
*	9209-037-002	Grommet.	1
5	9834-008-002	Hood Ass'y, Lint	1
6	8640-412-004	Nut, Whizlock	6
*	9822-031-001	Lint Screen 21"x36" (old style)	1
7	9576-207-006	Thermostat, Safety	1
*	9545-008-001	Screw, Hx. #10 x 1/4	2
8	9539-487-001	Switch, Lower Door	1
9	9029-097-001	Bracket, Lower Door Switch	1
*	9545-008-024	Screw	2
10	9278-038-004	Impeller, w/set screws	1
*	9345-836-003	Schematic Wiring	1
*	9345-837-003	Diagram Wiring	1

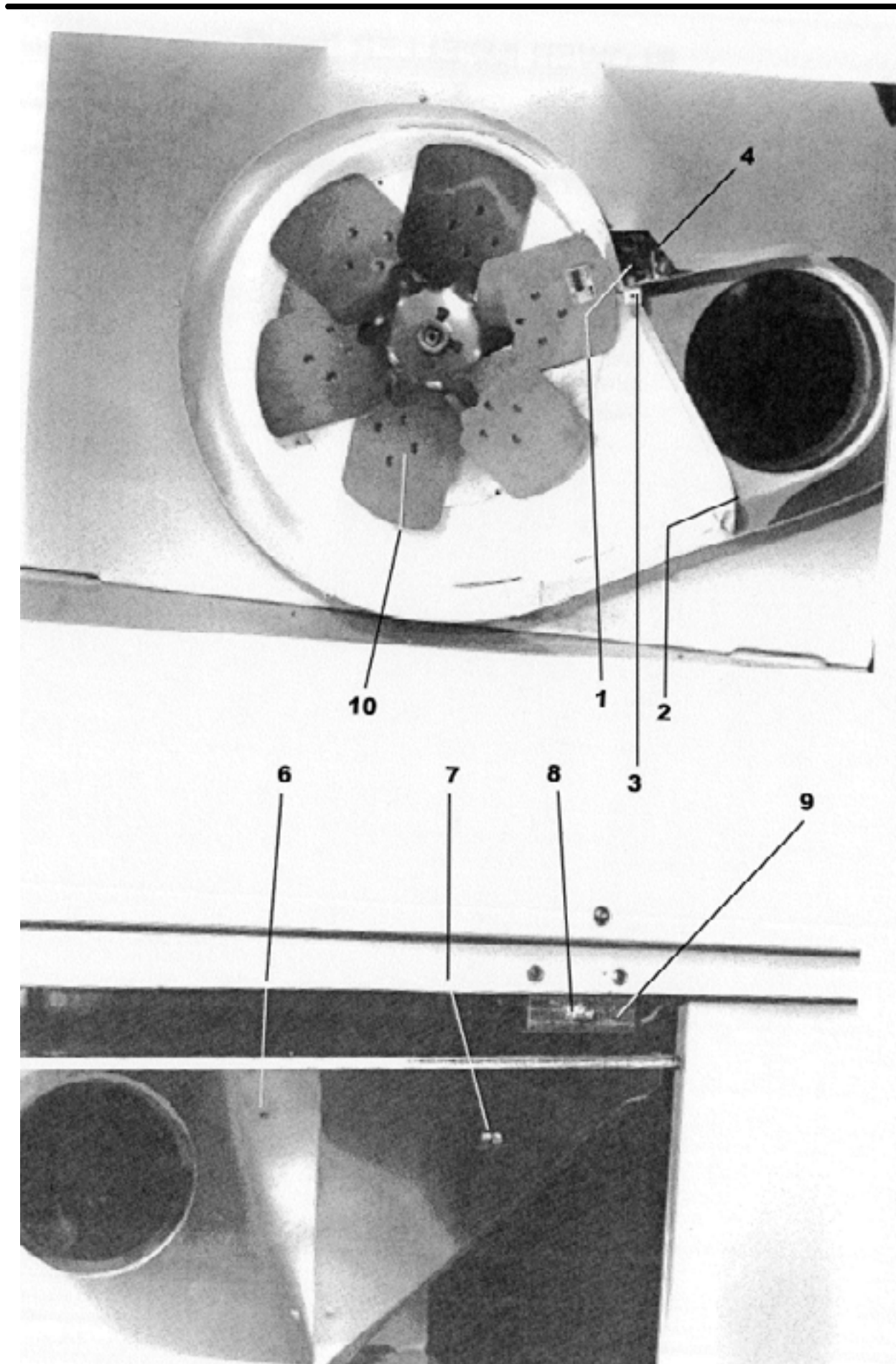

Lint Hood, & Blower Impeller Group Style No. 2 (in use since 1998)

Key	Part Number	Description	Qty
1	9822-031-002	Lint Screen Ass'y 21"x34"	1
2	9278-038-004	Impeller	1
3	9834-010-001	Hood assembly Lint	1
*	9345-840-003	Schematic Wiring (55lb, Rot 25 cents)	1
*	9345-841-003	Diagram Wiring (55lb Rotary 25 cents)	1
*	9345-838-003	Schematic Wiring (55lb Computer 25 cents)	1
*	9345-839-003	Diagram Wiring (55lb Computer 25 cents)	1

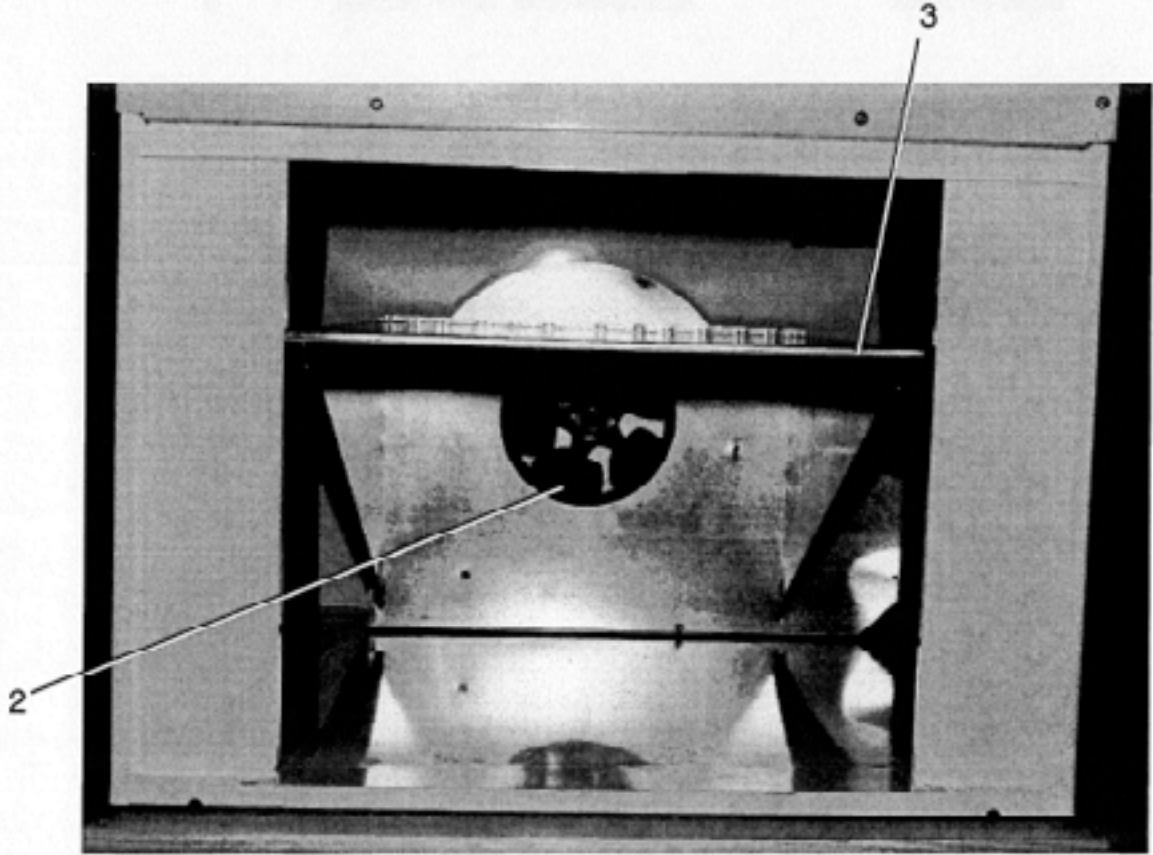
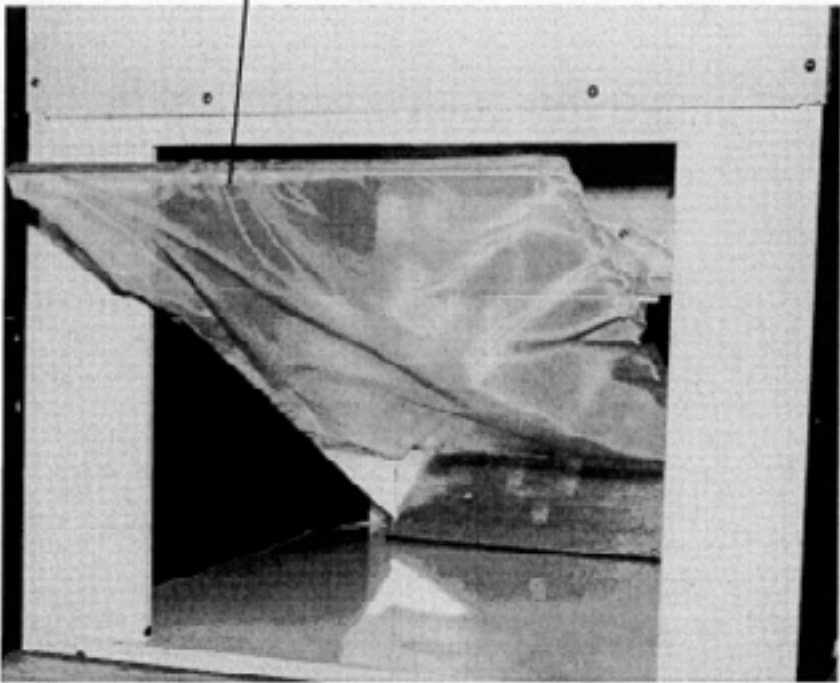

Blower Impeller and Airflow Switch Group Overtemperature Switch Style No. 2 (in use after 1998)

Key	Part Number	Description	Qty
1	9074-283-001	Cover Plate	1
2	9029-046-001	Actuator Stop	1
3	9029-100-001	Bracket -Switch	1
4	9545-008-001	Screw-JOB .x ¼	4
5	9539 461-009	Switch-Micro	1
6	9545 020-001	Screw 4-40 x %	2
7	8640-401-001	Nut Twin	1
8	9008-007-001	Actuator-Switch	1
9	9451-169-002	Pin Cotter	1
10	9039-575-000	Bracket Conduit	1
11	9825-057-002	Over-temp cover ass'y	1
12	9576-207-006	Thermostat Over-temp Manual Reset (Manually Resettable)	1
13	9545-008-001	Screw 108 x ¼	2
*	9486-137-001	Retainer; pushon	1
*	9535-050-003	Sleeve-Hi-Limit switch access	1

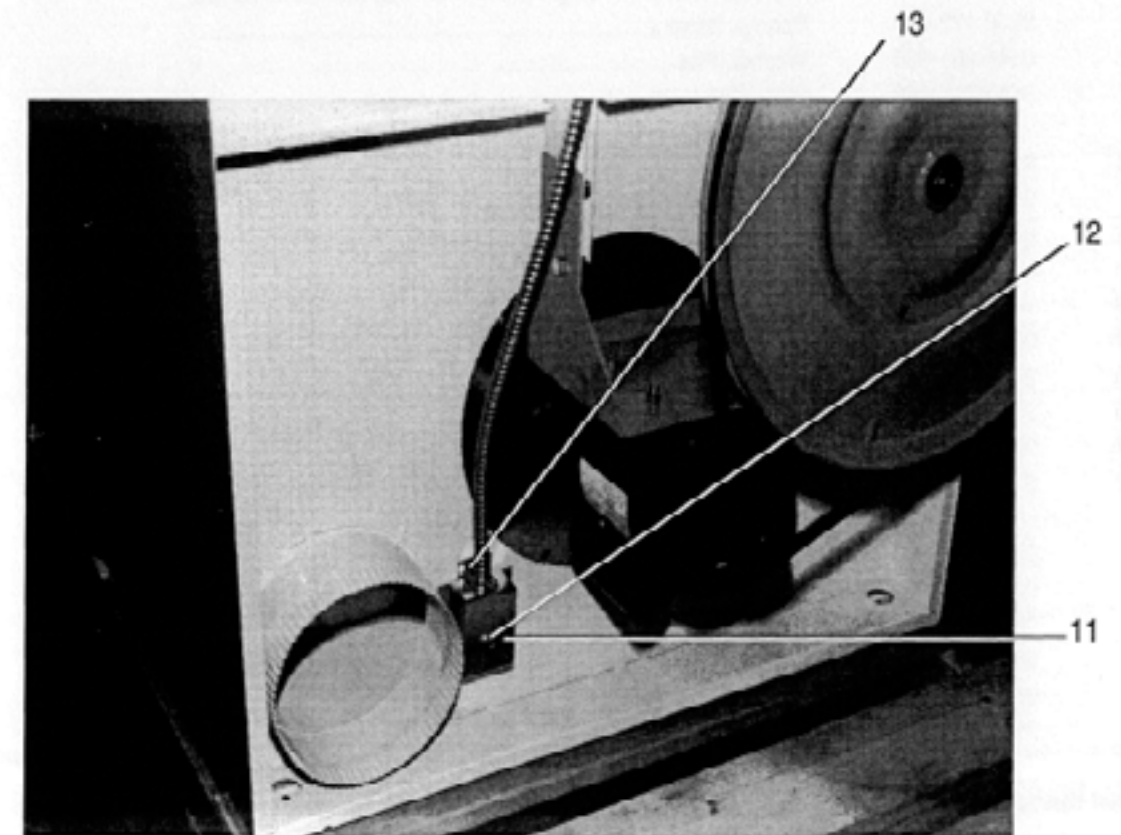
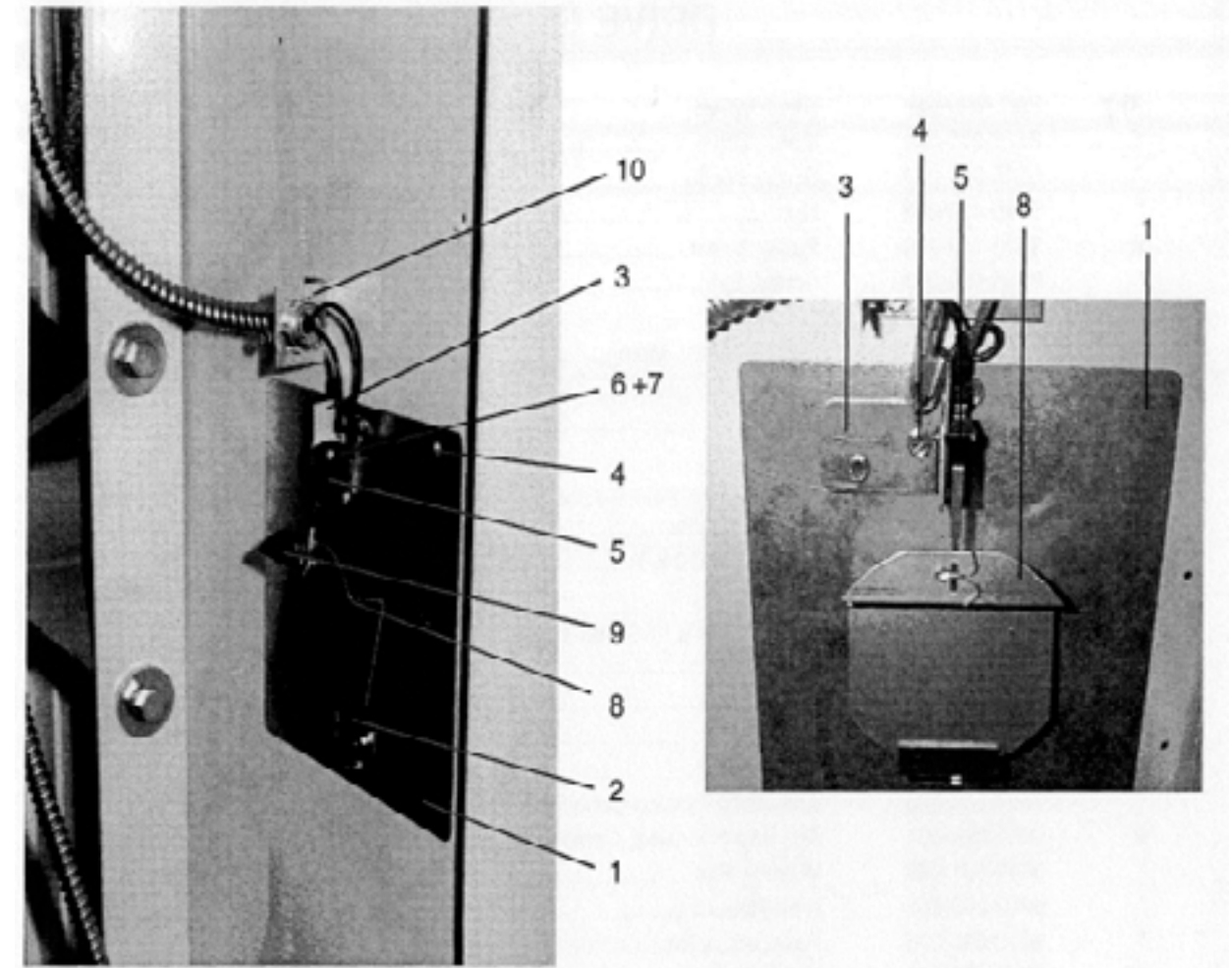

COIN BOX GROUP
Computer & Rotary Meter Only

Key	Part Number	Description	Qty
*	9732-122-001	Kit, Coin Box & Hardware (includes the following)	1
1	9807-077-007	Box Ass'y Coin	1
2	9349-033-001	Latch, Coin Box	1
3	8641-581-008	Washer, Latch Spacer(thick)	2
4	8641-581-010	Washer, Latch Spacer (thin)	4
5	8641-569-002	Washer, Wave	1
6	8641-583-001	Washer, Special Keeper	1
7	8650-012-002	Lock & Key Ass'y for Coinbox (includes key & nut)	1

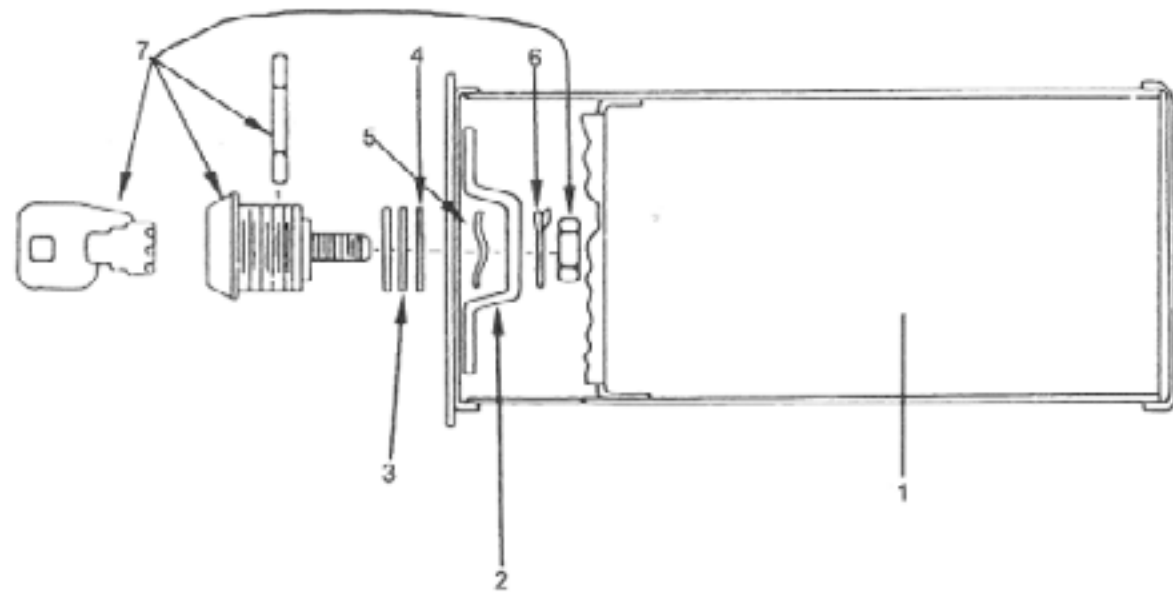

WIRING GROUP
ROTARY METER

Key	Part Number	Description	Qty
	8220-001-202	Wire, Hi-Limit to Junction Box(red 41 1/2")	1
	9631-382-001	Wiring---(blue 53 1/2")	1
	9627-711-001	Wiring Harness (low voltage)	1
	9631-400-001	Wire --(white 19")	1
	9631-403-003	Wire Ass'y--high voltage--	1
	8220-001-199	Wire Ass'y--motor to junction box	1
	8220-001-200	Wire Ass'y - motor to junction box	1
	8220-001-205	Wire Ass'y--junction box to customer connection-	1
	8220-001-220	Wire Ass"y--junction box to Run relay--	1
	8502-600-001	Label Warning & Notice	1
	8502-617-001	Label MADE IN U.S.A.	1
	8502-641-002	Label Instruction ,Warning	1
	8502-645-001	Label Instructions	1
	8511-001-002	Label Quality	1
	8514-028-003	Booklet Owners	1
	9631-381-004	Wire Terminal block to meter (gray 16 1/2")	1
	9631-381-003	Wire Cycling t- stat to meter(red/white 22 1/2")	1
	9631-381-002	Wire Terminal block to Start Switch (blue 20")	1

WIRING GROUP
COMPUTER

Key	Part Number	Description	Qty
	8220-001-199	Wire Motor to Junction Box	1
	8220-001-200	Wire Motor to Junction Box	1
	8220-001-205	Wire Junction Box to cust. conn.	1
	8220-001-461	Wire Wht. 58"	1
	8220-001-479	Wire Blu. 45"	1
	8220-001-480	Wire Blk. 45"	1
	8220-001-495	Wire Gry. 58"	1
	8220-001-496	Wire Blk. 58"	1
	9245-838-003	Wiring Label-Schematic	1
	9345-839-003	Wiring Label-Diagram	1
	9627-651-001	Wiring Harness Elec control	1
	9627-679-001	Wiring Harness	1
	9631-382-001	Wire Siu. 53 1/2"	1