



***DEXTER***<sup>®</sup>  
***LAUNDRY***

**USE THE BLUE TABS LOCATED ON THE  
RIGHT AND LEFT SIDES OF THE FOLLOWING  
DOCUMENT TO ADVANCE TO EACH SECTION.**

## Kits, Assemblies, & Common Parts

Coin Acceptor Components	Part Number
Mechanical Coin Acceptor	9021-001-010
Coin Drop Screws	9545-053-002
Retainer, Coin Acceptor	9486-149-001
Loading Door Components	Part Number
Door Handle	9244-093-001
Door Close Switch	9539-492-001
Electrical Components	Part Number
Relay, Motor Run (24VAC)	5192-299-002
Transformer, Control	8711-007-002
Controls 120VAC	9471-011-003
Heating Circuit Components	Part Number
Ignition Control Module	9857-182-001
Ignition Electrode Assembly	9875-002-003
Thermostat, Hi-Limit	9576-203-002
Thermostat, Overtemp	9576-207-006
Airflow Switch	9539-461-009
Cabinet Components	Part Number
Cleanout Duct Assembly 8"	9973-034-001



DCBD30KC\_-10  
DCBD50KC\_-10  
DCBD80KC\_-10

## Section 5: Dryer Parts Data

## Dryer Cabinet Group

Key	Description	T-30	T-50	T80	
1	Loading Door Complete SS/ Brushed SS/Blk	9960-306-001	9960-305-001	9960-305-001	1
1	Loading Door Complete Wht/ Brushed SS/Blk	9960-306-003	9960-305-003	9960-305-003	1
2	Door Assy, Loading (Ring only) Brushed SS	9960-255-008	9960-284-002	9960-284-002	1
3	Plate Assy, Hinge (SS)	9982-374-001	9982-368-001	9982-368-001	1
3	Plate Assy, Hinge (Wht)	9982-374-003	9982-368-003	9982-368-003	1
*	Cover-Hinge Back, Black	9074-341-002	9074-340-002	9074-340-002	1
*	Screw-10Bx3/8, Black	9545-008-010	9545-008-010	9545-008-010	2
*	Screw Hinge to Door	9545-012-015	9545-012-015	9545-012-015	4
*	Nut, Hinge to Door	8640-413-002	8640-413-002	8640-413-002	4
4	Glass, Door	9212-002-003	9212-002-004	9212-002-004	1
5	Gasket, Door Glass (Black)	9206-413-001	9206-413-002	9206-413-002	1
*	Support Door Glass	9548-117-000	9548-117-000	9548-117-000	2
6	Gasket, Door Outer Rim (Black)	9206-420-003	9206-420-005	9206-420-005	1
7	Handle, Loading Door	9244-082-001	9244-082-001	9244-082-001	1
*	Screw, Handle	9545-018-017	9545-018-017	9545-018-017	2
8	Stud Door Catch	9531-033-001	9531-033-002	9531-033-002	1
9	Nut-Hex, #10-32	8640-413-001	8640-413-001	8640-413-001	1
10	Nut, Acorn	8640-413-003	8640-413-003	8640-413-003	1
*	Catch, Loading Door	9086-015-002	9086-015-002	9086-015-002	2
*	Rivit	8638-190-009	8638-190-009	8638-190-009	4
11	Strap, Hinge (Black)	9966-015-002	9966-014-002	9966-014-002	1
*	Plate Assy-Backup, Hinge	9982-371-001	9982-356-001		1
*	Plate Assy-Backup, Hinge			9982-369-001	1
*	Reinforcement-Front panel			9817-003-001	1
12	Screw-Phillips, 10-32x1/2 Chrome	9545-012-003	9545-012-003	9545-012-003	4
*	Screw-Phillips-Counter sink, 10- 32x1/2 Chrome	NA	9545-012-028	9545-012-028	4
13	Screw-Special, Hinge to Door	9545-052-001	9545-052-001	9545-052-001	1
*	Nut-Allen, 1/4-20	8640-439-001	8640-439-001	8640-439-001	1
14	Washer-Fiber/Plastic	8641-436-003	8641-436-003	8641-436-003	1
15	Front Panel Assy (SS)	9454-869-001	9454-865-001	9454-867-001	1
15	Front Panel Assy (Wht)	9454-869-003	9454-865-003	9454-867-003	1
16	Screw-Phillips, 10Bx1 3/4	9545-008-014	9545-008-014	9545-008-014	4
17	Washer-Finish	8641-585-001	8641-585-001	8641-585-001	4
*	Nut-Spring	8640-399-001	8640-399-001	8640-399-001	4
*	Insulation-Front Panel, Top Half	9277-062-001	9277-057-001	9277-058-001	1
*	Insulation-Front Panel, Bottom Half	9277-062-002	9277-057-001	9278-058-002	1
*	Switch-Door Closed	9539-492-001	9539-492-001	9539-492-001	1
*	Wire-Assy, Blk	8220-063-026	8220-063-026	8220-063-026	1
*	Wire-Assy-Blu	8220-063-009	8220-063-009	8220-063-009	1
20	Coin Box Blue	9807-099-002	9807-099-002	9807-099-002	1
20	Coin Box Black	9807-099-004	9807-099-004	9807-099-004	1
*	Cabinet Touch Up Paint (White)	9472-001-013	9472-001-013	9472-001-013	1

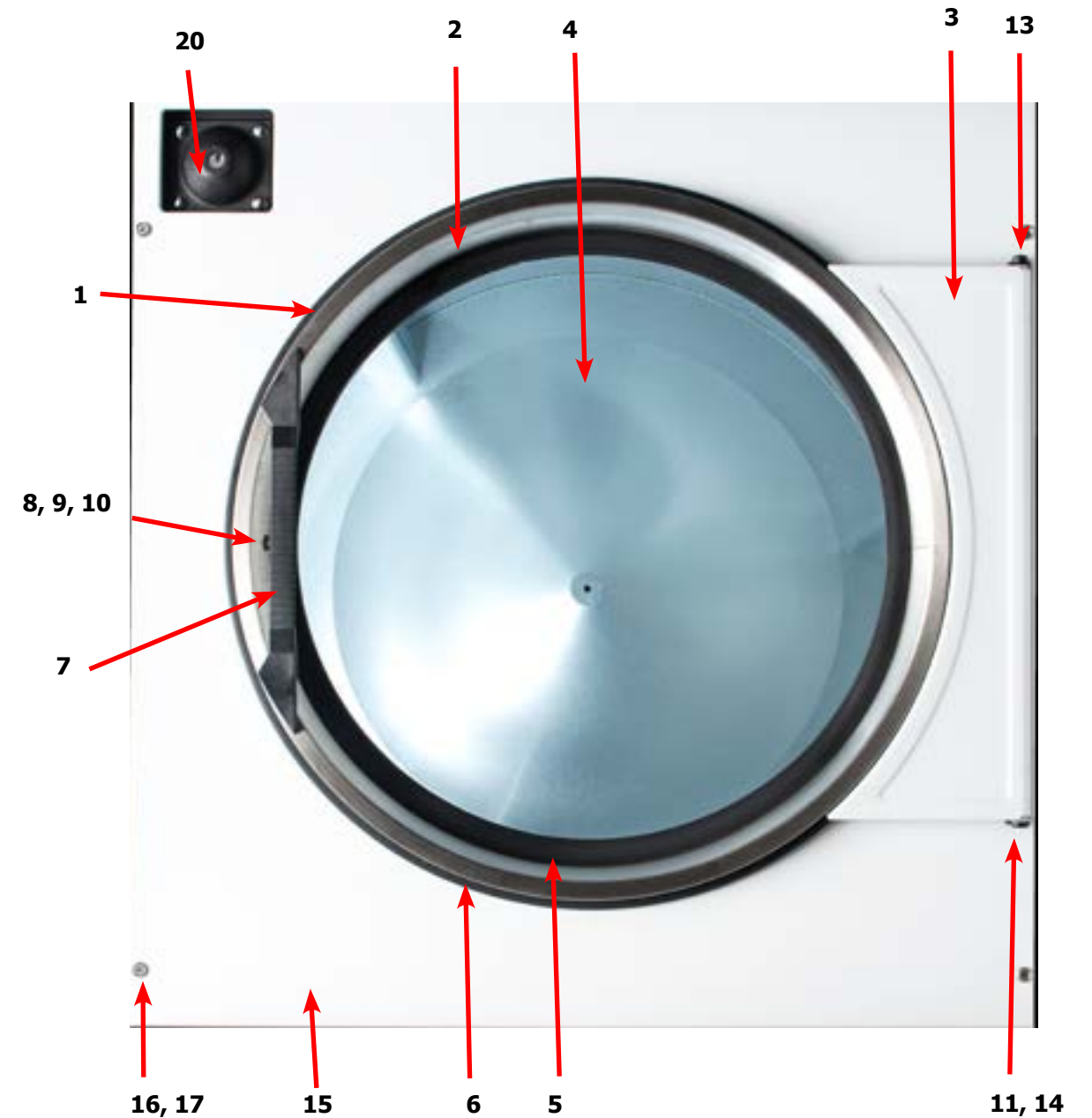

## Dryer Cabinet Group Continued

Key	Description	T-30	T-50	T80	QTY
1	Nameplate - Dexter Dryer Blue	9412-083-001	9412-083-001	9412-083-001	1
1	Nameplate - Dexter Dryer Black	9412-174-001	9412-174-001	9412-174-001	1
2	Additional Nameplate (Black only)	9412-175-001	9412-178-001	9412-177-001	1
3	Door Assy-Upper, Coin (SS)	9960-287-001	9960-289-001	9960-291-001	1
3	Door Assy-Upper, Coin (Wht)	9960-287-003	9960-289-003	9960-291-003	1
*	Bracket-Hinge	9029-224-001	9029-224-001	9029-224-001	2
*	Rivit- 3/16, Hinge to Door	9491-009-001	9491-009-001	9491-009-001	2
*	Rivit- 3/16, Hinge to Cabinet	9491-009-001	9491-009-001	9491-009-001	AR
4	Trim-Upper Service Door, Black	9578-098-002	9578-094-002	9578-096-002	1
5	Screw-Phillips, 10Bx3/8, Black	9545-008-010	9545-008-010	9545-008-010	4
6	Label Instructions Blue	8502-746-002	8502-746-002	8502-746-002	1
6	Label Instructions Black	8502-746-001	8502-746-001	8502-746-001	1
7	Label Warning	8502-748-016	8502-748-016	8502-748-016	1
8	Lock Assy and Key Upper	8650-012-003	8650-012-003	8650-012-003	1
9	Cam Lock Upper Door	9095-047-001	9095-047-001	9095-047-001	1
*	Key, FJWCC	6292-006-006	6292-006-006	6292-006-006	1
10	Membrane Switch Blue	9801-102-002	9801-102-002	9801-102-002	1
10	Membrane Switch Black	9801-102-001	9801-102-001	9801-102-001	1
11	PCB-Controler	9471-011-003	9471-011-003	9471-011-003	1
*	Spacer-#6 x 1/2	9538-157-016	9538-157-016	9538-157-016	3
*	Spacer #6 x 7/8	9538-157-017	9538-157-017	9538-157-017	2
*	Nut- #6-32	8640-411-003	8640-411-003	8640-411-003	4
	Nut- #6-32 (Grounding nut)	8640-411-001	8640-411-001	8640-411-001	1
12	Wire Assy-GRN, 24"	8220-137-001	8220-137-001	8220-137-001	1
13	Support-Upper Service Door	9548-288-001	9548-288-002	9548-288-002	1
14	Clamp-Tube	9079-121-002	9079-121-002	9079-121-002	2
*	Nut, #6-32	8640-411-003	8640-411-003	8640-411-003	2
15	Clamp-Cable, 1/2"	8654-125-006	8654-125-006	8654-125-006	1
*	Nut, #6-32	8640-411-003	8640-411-003	8640-411-003	1
16	Insulation	9277-041-016	9277-041-016	9277-041-016	1
17	Coin Acceptor	9021-001-010	9021-001-010	9021-001-010	1
18	Retainer-Coin Accepctor	9486-149-001	9486-149-001	9486-149-001	2
19	Screws-Torq, 4Bx5/8 ss	9545-053-002	9545-053-002	9545-053-002	4
*	Coin Switch, Kit	9732-126-001	9732-126-001	9732-126-001	1
*	Coin Shute	9940-016-001	9940-016-001	9940-016-001	1
*	Screw	9545-008-001	9545-008-001	9545-008-001	1
*	Nut, Elastic Stop	8640-413-004	8640-413-004	8640-413-004	*

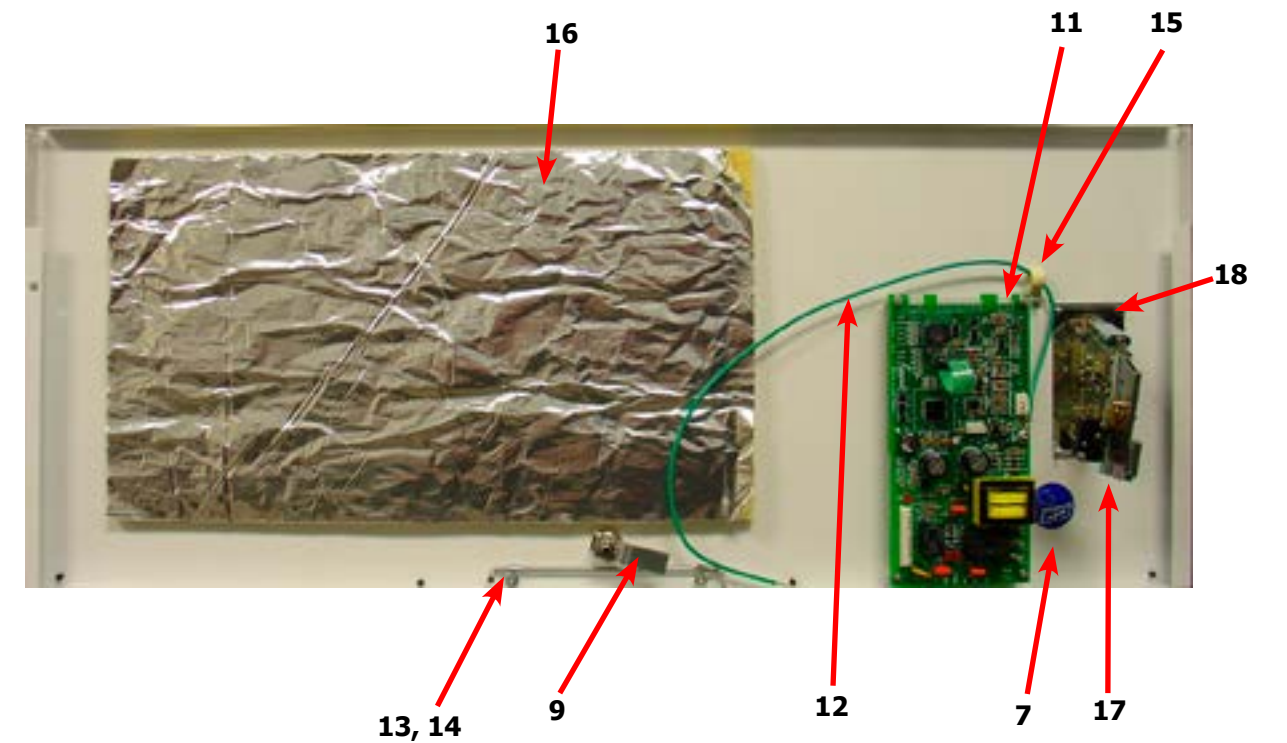



## Dryer Cabinet Group Continued

Key	Description	T-30	T-50	T80	QTY
1	Door-Lower Service, Coin, SS	9108-130-001	9108-122-001	9108-126-001	1
1	Door-Lower Service, Coin, Wht	9108-130-003	9108-122-003	9108-126-003	1
2	Lock Assy and Key Lower Door	8650-012-004	8650-012-004	8650-012-004	1
*	Cam Lock Lower Door	9095-048-001	9095-048-001	9095-048-001	1
*	Washer-Flat	8641-581-041	8641-581-041	8641-581-041	2
3	Handle-Door, Lower Service OPL	9244-084-002	9244-087-002	9244-088-002	1
4	Screw-Phillips, 10Bx3/8, Black	9545-008-010	9545-008-010	9545-008-010	5
5	Trim-Lower Kick, Black	9578-099-002	9578-095-002	9578-097-002	1
6	Screw-Phillips, 10Bx3/8, Black	9545-008-010	9545-008-010	9545-008-010	4
7	Screen Assy, Lint	9822-026-002	9822-026-001	9822-031-002	1
8	Switch-Door Closure (Round)	9539-492-001	9539-492-001	9539-492-001	1
*	Kit, Optional Replacement for Round Switch 9539-492-001	9732-351-001	9732-351-001	9732-351-001	1
9	Hinge-Door, Lower	9243-081-001	9243-082-001	9243-082-001	1
10	Screw-5/16, 10ABx3/8	9545-008-024	9545-008-024	9545-008-024	5
11	Bracket-Door Switch	9029-226-001	9029-226-001	9029-226-001	1
*	Rivit, 1/8 Low Profile	9491-009-004	9491-009-004	9491-009-004	2
12	Bracket-Chain	9029-223-001	9029-223-001	9029-223-001	2
*	Rivit, 1/8 Low Profile	9491-009-004	9491-009-004	9491-009-004	8
13	Hook, "S" Type	9248-022-002	9248-022-002	9248-022-002	4
14	Chain	9099-012-006	9099-012-006	9099-012-006	2
*	Leg, Leveling 1/2"	8544-006-001	8544-006-001	8544-006-001	4

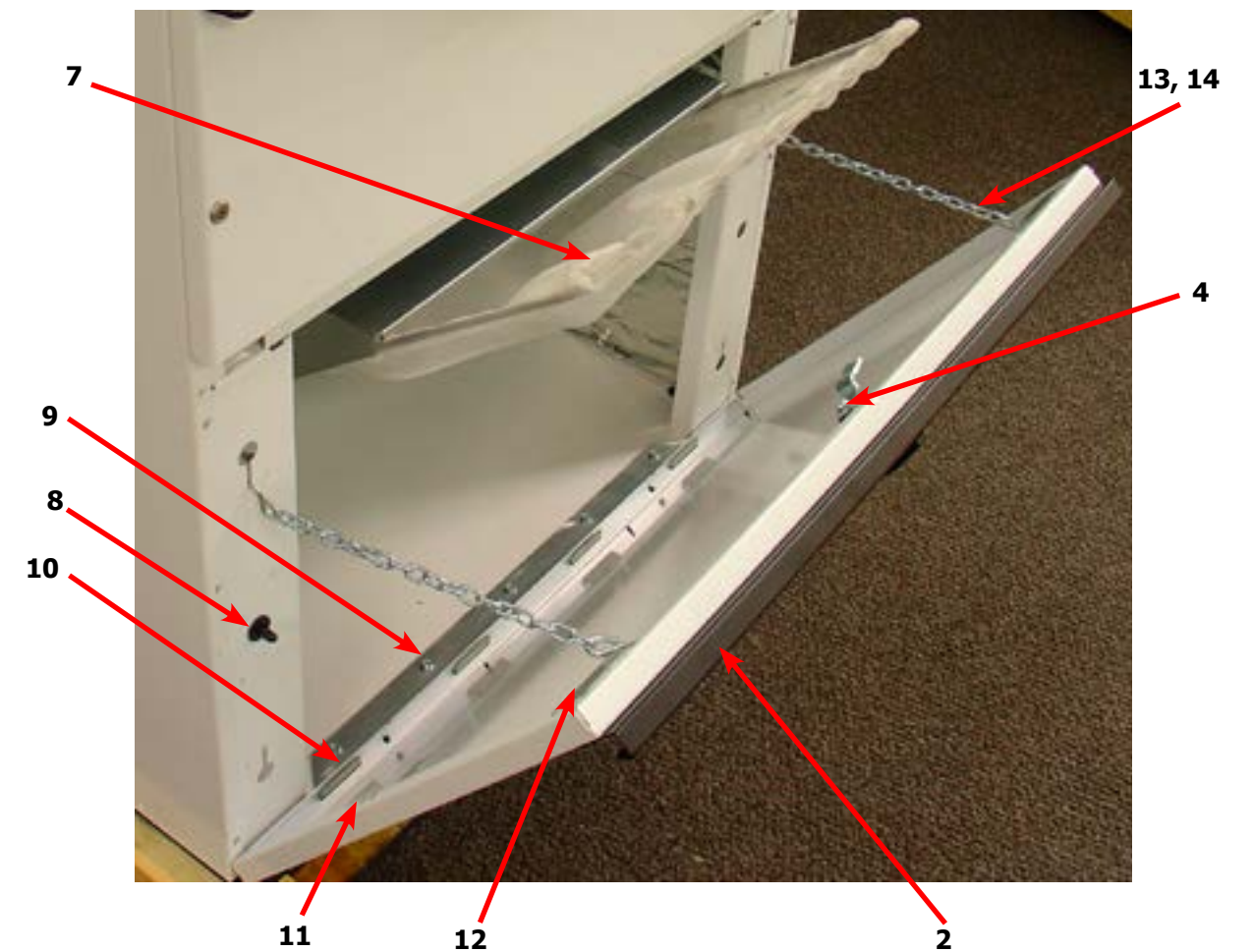
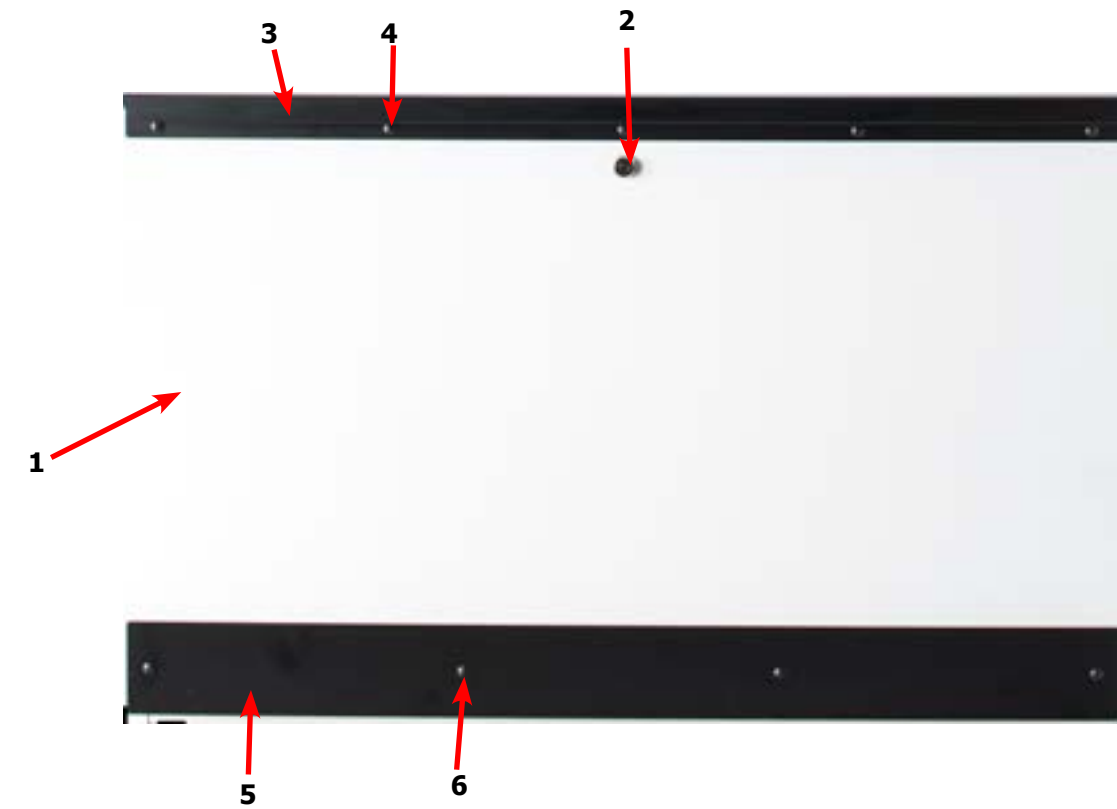

## Dryer Cabinet Group Continued

Key	Description	T-30	T-50	T80	QTY
1	Insulation, Upper service Door	9277-041-006	9277-041-016	9277-041-016	1
2	Insulation, RH Burnner	9277-041-019	9277-041-019	9277-041-023	1
3	Insulation Tumbler Area, above Baffle	9277-041-020	9277-051-003	9277-041-021	2
3	Insulation Tumbler Area, above Baffle		9277-051-003	9277-041-021	2
4	Insulation Tumbler Area, below baffle	9277-041-020	9277-051-003	9277-051-004	2
4	Insulation Tumbler Area, below baffle		9277-051-003	9277-051-004	2
5	Insulation Lint Compartment	9277-041-021	9241-041-024	9277-041-025	2
*	Screen Assy, Lint	9822-026-002	9822-026-001	9822-031-002	1
6	Switch-Door Closure	9539-492-001	9539-492-001	9539-492-001	1
7	Hinge-Door, Lower	9243-081-001	9243-082-001	9243-082-001	1
8	Screw-5/16, 10ABx3/8	9545-008-024	9545-008-024	9545-008-024	AR
9	Lint Hood-Back	9240-038-001	9240-041-001	9240-044-001	1
10	Nut Wizlock, 8-32	8640-412-004	8640-412-004	8640-412-004	6
11	Lint hood, LH	9240-040-001	9240-043-001	9240-046-001	1
12	Lint hood, RH	9240-040-002	9240-043-002	9240-046-002	1
13	Lint hood, Top	9240-039-001	9240-042-001	9240-045-001	1
14	Screw, 5/16- 10ABx3/8	9545-008-024	9545-008-024	9545-008-024	14
15	Impeller, w/set screws	9278-043-001	9278-038-004	9278-037-003	1
16	Harness -Temp Probe	9627-679-002	9627-679-002	9627-679-002	1
17	Wire Nut, #71B	8640-276-005	8640-276-005	8640-276-005	2
18	Bracket, Temp Probe	9029-197-001	NA	NA	1
19	Screw-5/16, 10ABx3/8	9545-008-024	NA	NA	1
20	Temp Probe	9501-004-002	9501-004-002	9501-004-002	1
21	Screw-Phillips, 8Bx1/4	9545-045-005	9545-045-005	9545-045-005	1
22	Vault, Coin	9942-039-002	9942-039-002	9942-039-002	1
*	Plate Assy/Coin vault mounting	9982-338-001	9982-338-001	9982-338-001	1
*	Nut/ Hexelastic stop	8640-413-004	8640-413-004	8640-413-004	2
23	Coin Shute	9940-016-001	9940-016-001	9940-016-001	1
*	Screw, 10Bx1/4	9545-008-001	9545-008-001	9545-008-001	1

**30lb Temp Probe**

**50Lb & 80Lb Temp Probe**

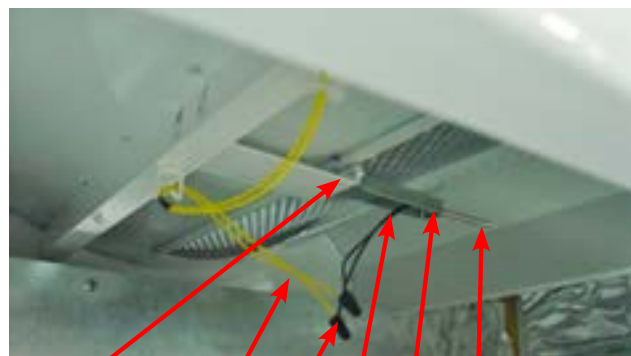

19 16 17 18 21 20

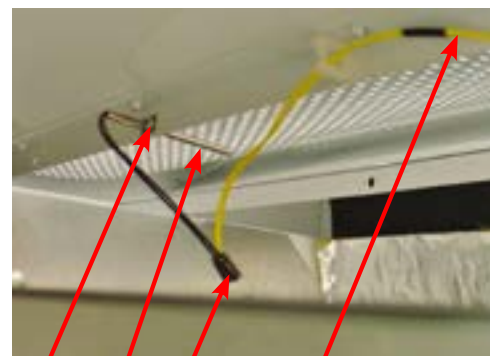

21 20 17 16

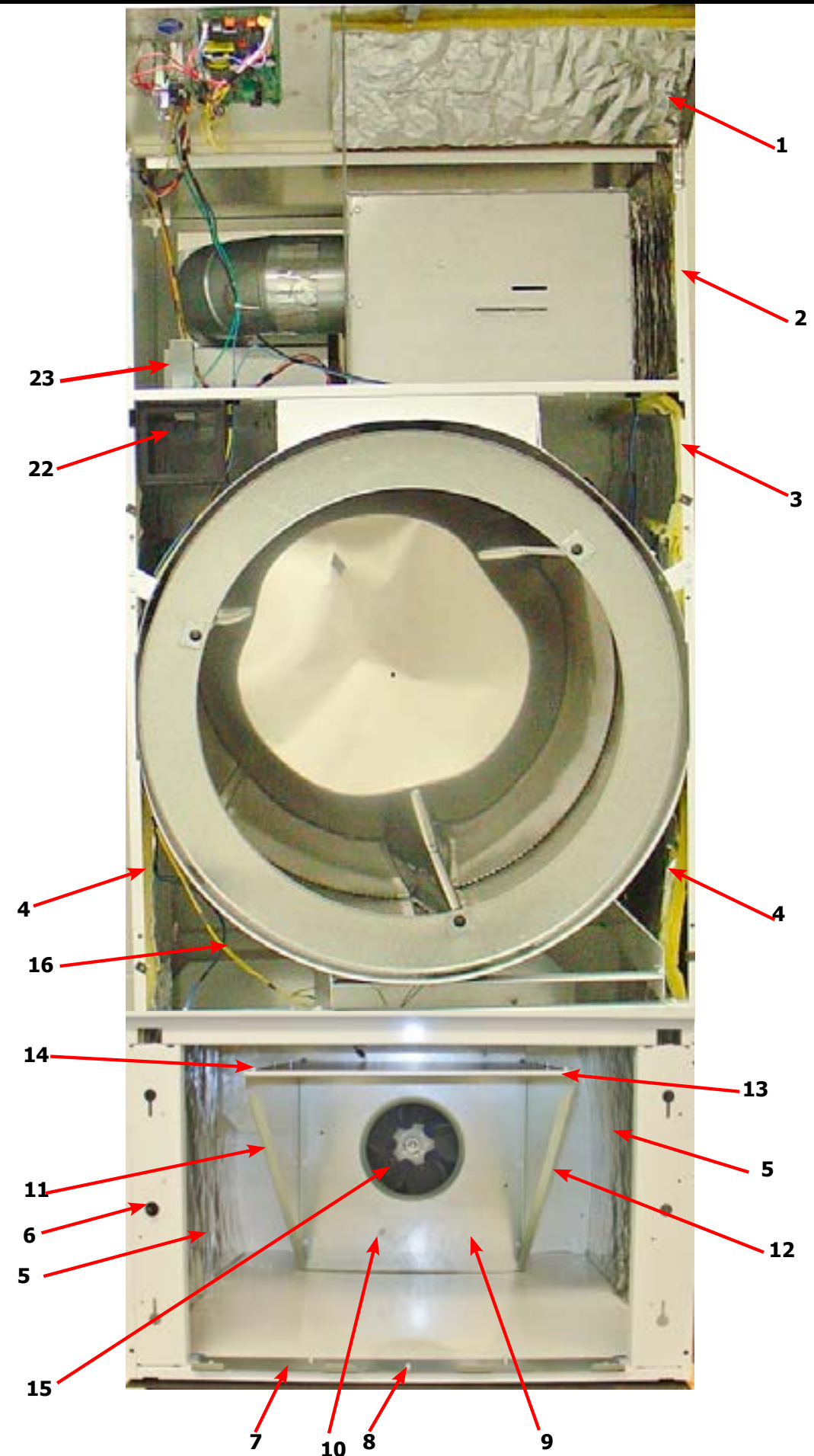



## Dryer Rear View 30Lb

Key	Description	T-30	QTY
1	Motor	9376-311-003	1
2	Pulley	9453-157-001	1
*	Set screw	9545-028-013	1
3	Plate, Motor mounting	9982-370-002	1
*	Gasket, Motor Plate	9206-428-001	1
4	Nut-3/8-16, Plate to cabinet	8640-415-004	4
*	Impeller w/set screw	9278-043-001	1
5	Screw, 5/16-18x5/8	9545-014-004	4
6	Nut, 3/8-16	8640-415-004	4
7	Support Arm, Intermediate pulley	9991-053-001	1
8	Bolt- 3/8-16x1 1/4	9545-029-010	3
9	Nut, Wizlock, 3/8x16	8640-415-004	3
*	Cap Screw, 3/8-16x1 1/2	9545-029-003	1
*	Snap Ring	9487-200-003	1
*	Washer-Flat, 3/8x1	8641-581-020	1
10	Idler Arm Assembly	9861-022-001	1
11	Washer-Flat, 3/8x1	8641-581-020	2
12	Pulley, Idler w/Bearings	9908-039-004	1
13	Bearing, Bronze	9036-145-002	2
14	Snap Ring	9487-200-003	1
15	Hook "S" type	9248-022-002	3
16	Chain, Spring tension	9099-012-002	1
17	Spring, tension	9534-319-002	1
18	Chain, Limit	9099-012-007	1
19	Belt Drive	9040-076-003	1
*	Tolerance Ring	9487-234-005	1
20	Pulley, Driven	9908-049-002	1
21	Washer-Flat, 1/2	8641-581-021	1
22	Washer-Lock, Ext. tooth, 1/2	8641-582-016	1
23	Bolt-3/4, 1/2-13x1/14	9545-017-019	1
24	Belt, Driven	9040-073-009	1

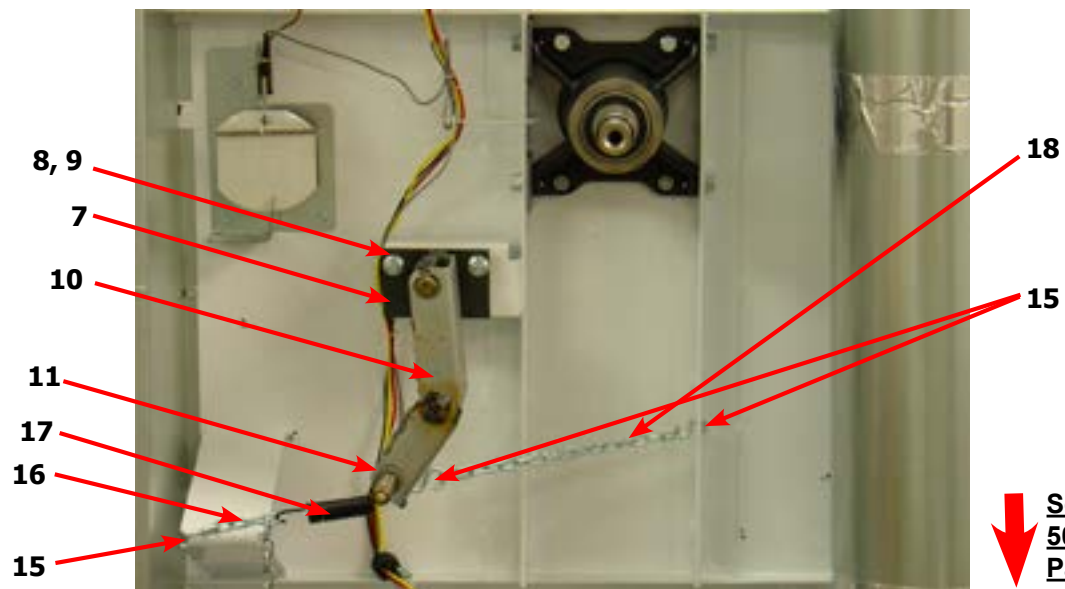

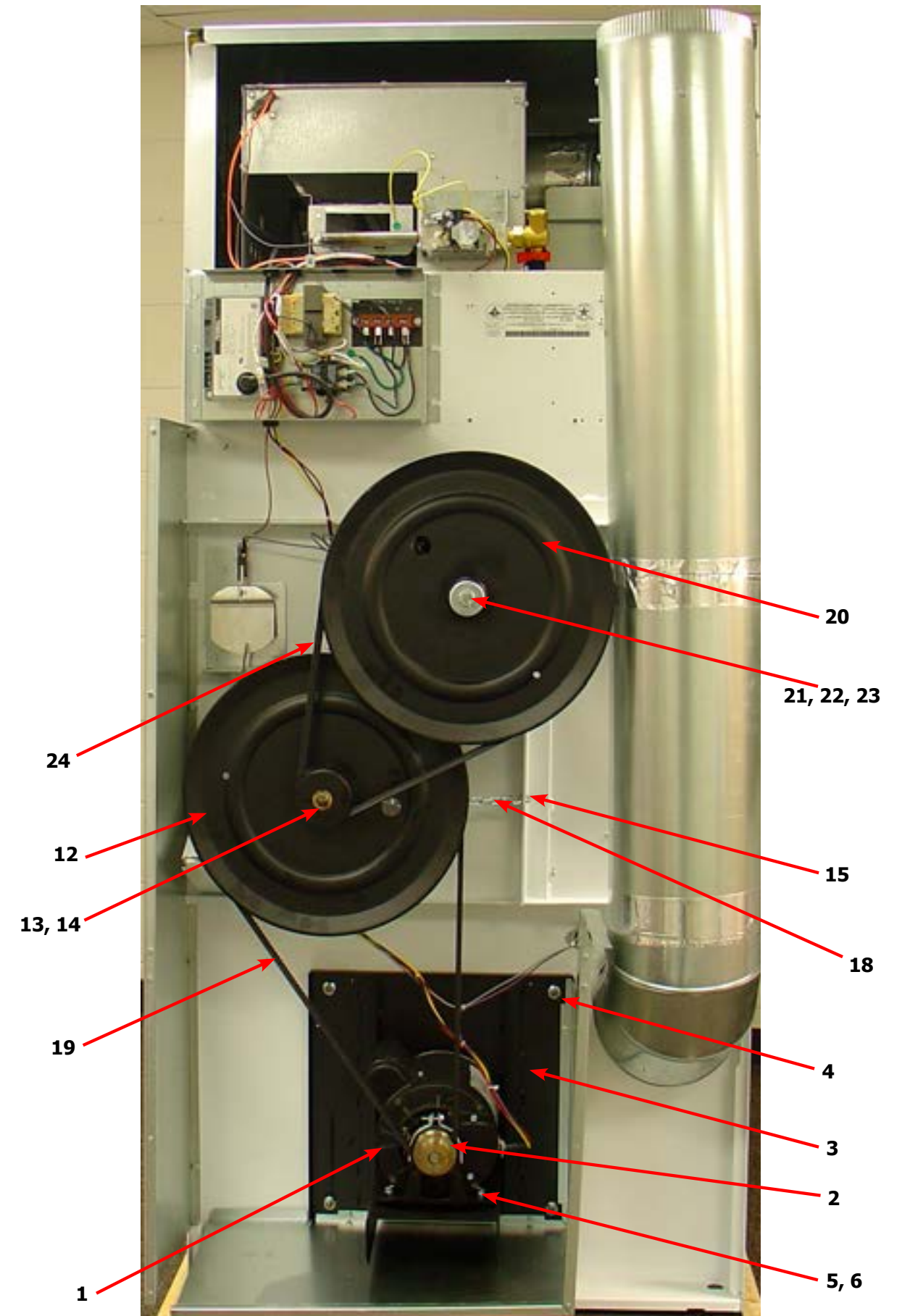

**Scroll down for  
50lb and 80lb  
Parts Breakdown**

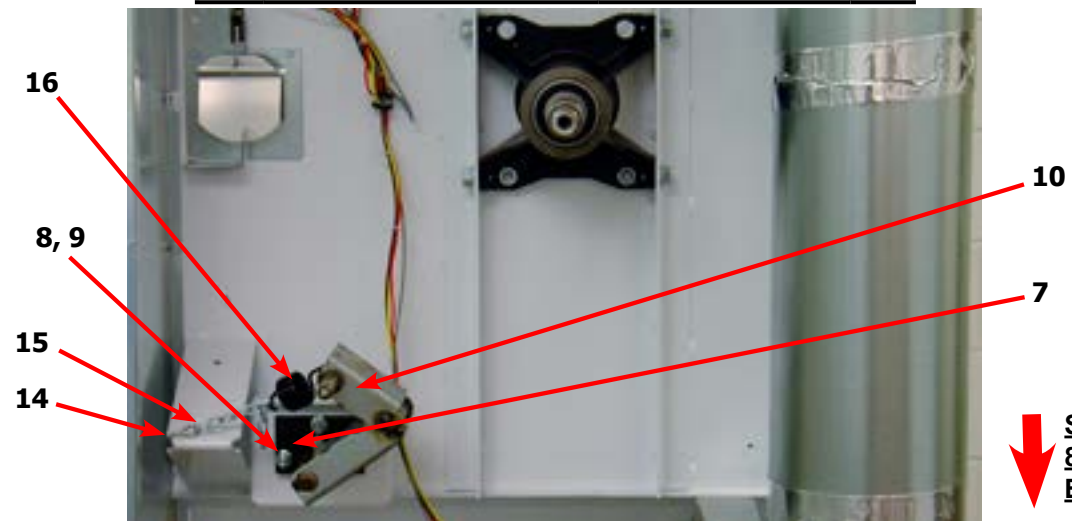

Key	Description	T-50	QTY
1	Motor	9376-317-003	1
*	Run Capacitor, Motor	5191-108-001	1
*	Start Capacitor, Motor	5191-109-001	1
2	Pulley	9453-169-013	1
*	Set screw	9545-028-013	1
3	Plate, Motor mounting	9982-370-002	1
*	Gasket, Motor Plate	9206-428-001	1
4	Nut-3/8-16, Plate to cabinet	8640-415-004	4
*	Impeller w/set screw	9278-038-004	1
5	Screw, 5/16-18x5/8	9545-014-004	4
6	Nut, 3/8-16	8640-415-004	4
7	Support Arm, Intermediate pulley	9991-053-002	1
8	Bolt- 3/8-16x1 1/4	9545-029-010	3
9	Nut, Wizlock, 3/8x16	8640-415-004	3
*	Cap Screw, 3/8-16x1 1/2	9545-029-012	1
*	Snap Ring	9487-200-003	1
*	Washer-Flat, 3/8x1	8641-581-035	1
10	Idler Arm Assembly	9861-022-002	1
*	Snap Ring (Support Arm keeper)	9487-200-003	1
*	Snap Ring	9487-200-003	1
*	Washer-Flat, 3/8x1	8641-581-035	1
11	Pulley, Idler w/Bearings	9908-048-003	1
12	Bearing, Bronze	9036-145-002	2
13	Snap Ring	9487-200-003	1
14	Hook "S" type	9248-022-002	3
15	Chain, Spring tension	9099-012-002	1
16	Spring, tension	9534-151-000	1
17	Belt Drive	9040-076-006	1
*	Tolerance Ring	9487-234-005	1
18	Pulley, Driven	9908-047-002	1
19	Washer-Flat, 1/2	8641-581-026	1
20	Washer-Lock, Ext. tooth, 1/2	8641-582-016	1
21	Bolt-3/4, 1/2-13x1/14	9545-017-009	1
22	Belt, Driven	9040-073-011	1
23	Thermostat-Overtemp, Reset	9576-207-006	1

## Dryer Rear View 50 Lb



↓ Scroll down for 80lb Parts Breakdown

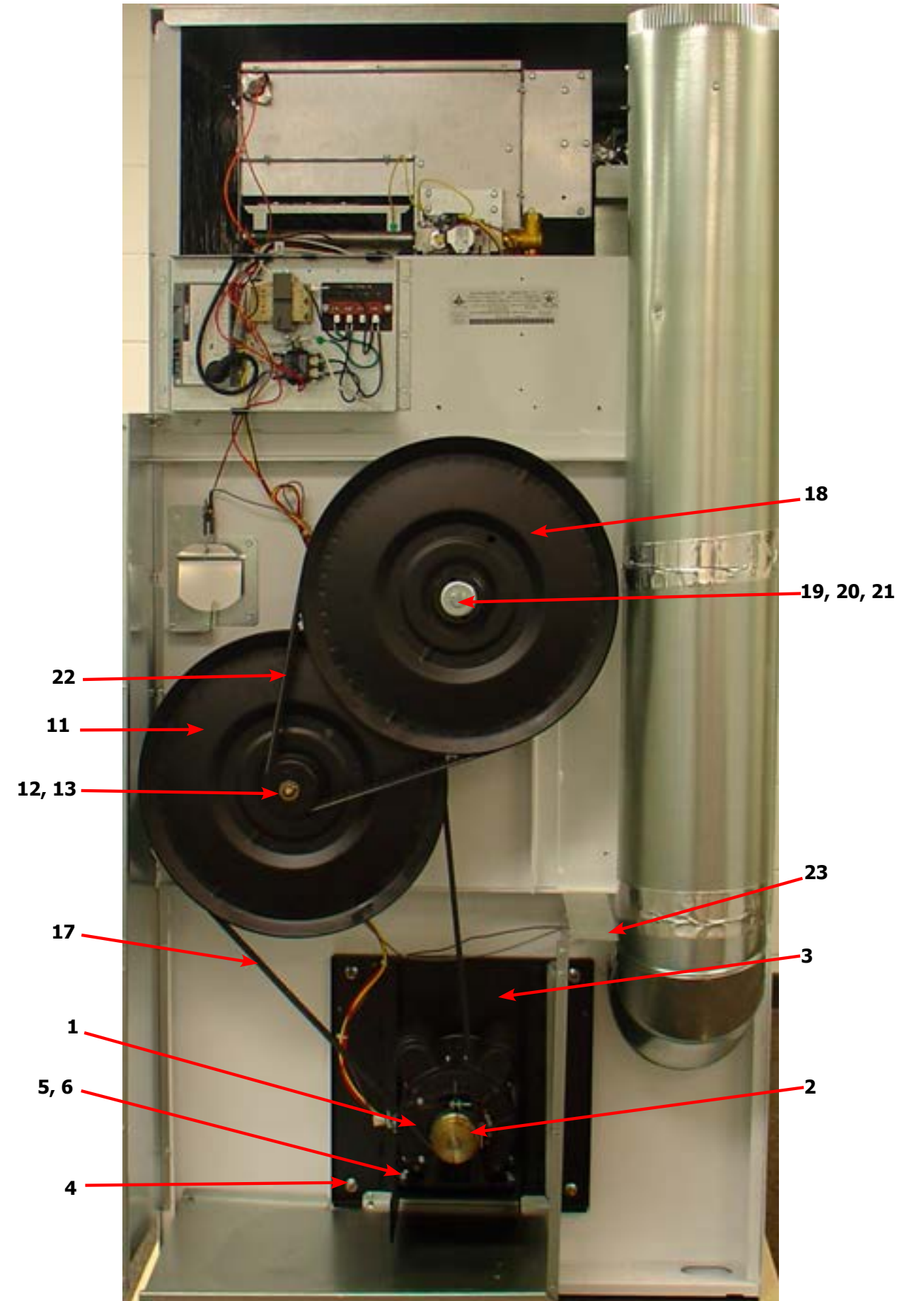



Key	Description	T-80	QTY
1	Motor	9376-317-003	1
*	Run Capacitor, Motor	5191-108-001	1
*	Start Capacitor, Motor	5191-109-001	1
2	Pulley	9453-157-001	1
*	Set screw	9545-028-013	1
3	Plate, Motor mounting	9982-372-002	1
*	Gasket, Motor Plate	9206-428-001	1
4	Nut-3/8-16, Plate to cabinet	8640-415-004	4
*	Impeller w/set screw	9278-037-003	1
5	Screw, 5/16-18x5/8	9545-014-004	4
6	Nut, 3/8-16	8640-400-003	4
*	Tolerance Ring	9487-234-001	1
7	Pulley, Driven	9908-043-002	1
8	Washer-Flat, 1/2	8641-581-026	1
9	Washer-Lock, Ext. tooth, 1/2	8641-582-016	1
10	Bolt-3/4, 1/2-13x1/4	9545-017-009	1
11	Support Arm, Intermediate pulley	9991-053-002	1
12	Bolt- 3/8-16x1 1/4	9545-029-010	3
13	Nut, Wizlock, 3/8x16	8640-415-004	3
*	Cap Screw, 3/8-16x1 1/2	9545-029-002	1
*	Snap Ring	9487-200-003	1
*	Washer-Flat, 3/8x1	8641-581-035	1
14	Idler Arm Assembly	9861-024-002	1
*	Snap Ring	9487-200-006	
*	Washer-Flat, 5/8	8641-581-039	1
15	Pulley, Idler w/Bearings	9908-042-006	1
*	Snapping, Inside-Bearing	9487-238-005	1
*	Bearing, Ball	9036-159-007	2
*	Spacer, Bearing	9538-173-002	1
16	Washer-Flat	8641-581-039	1
17	Nut, 5/8-11	8640-425-002	1
18	Hook "S" type	9248-022-002	3
19	Chain, Spring tension	9099-012-002	1
20	Spring, tension	9534-151-000	1
21	Belt Drive	9040-076-011	1
22	Belt, Driven	9040-073-012	1
23	Thermostat-Overtemp, Reset	9576-207-006	1

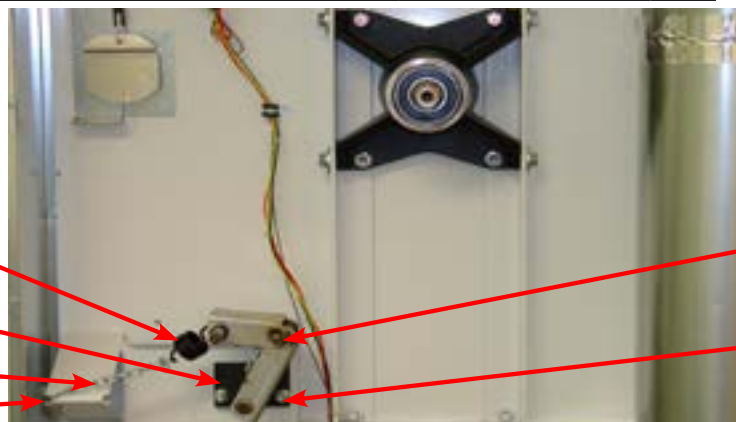

## Dryer Rear View 80 Lb

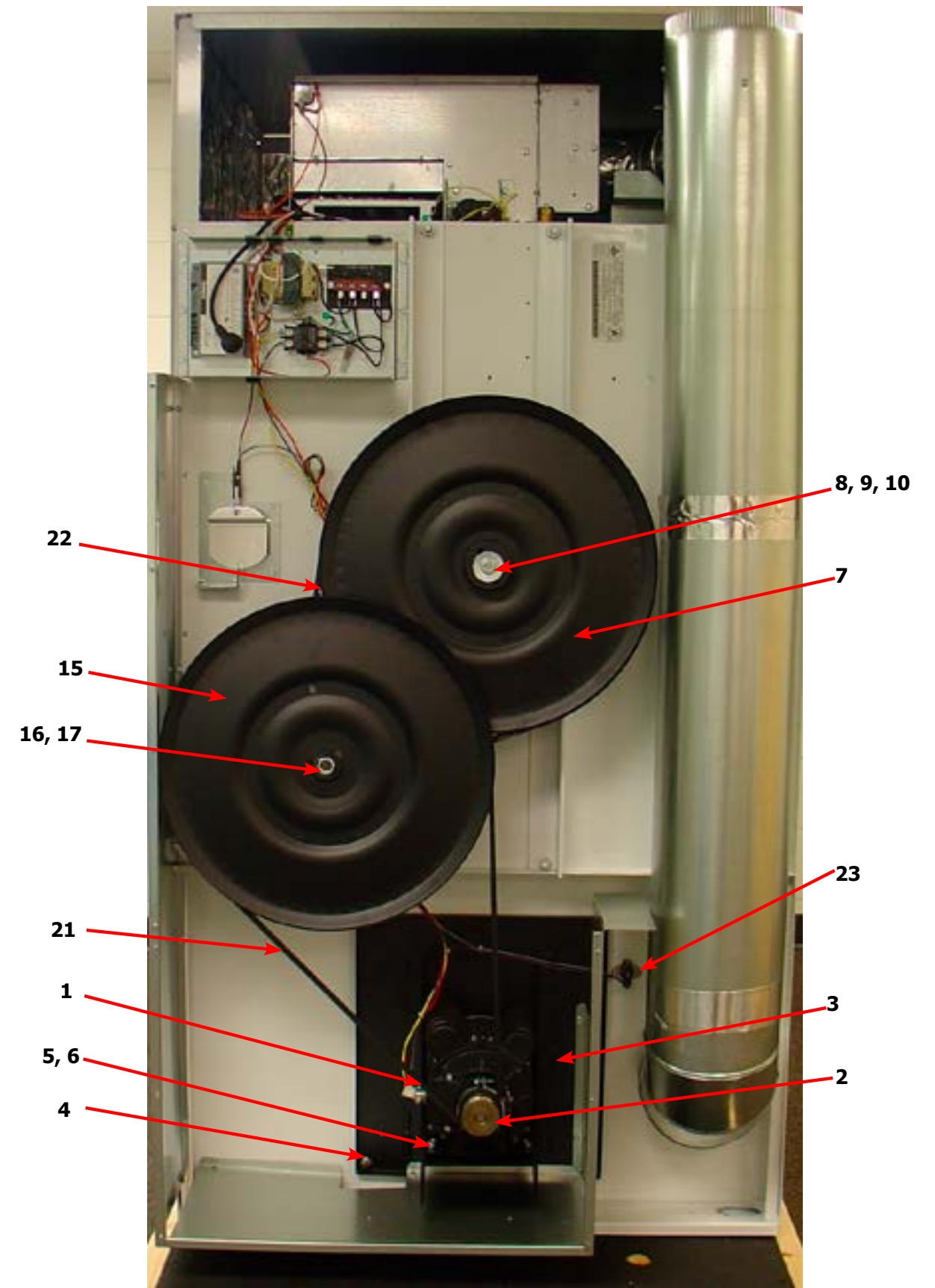

## Dryer Rear View-Guard & Exhaust

Key	Description	T-30	T-50	T80	QTY
1	Cover Cabinet	9074-347-001	9074-348-001	9074-349-001	1
*	Screw-5/16, 10ABx3/8	9545-008-024	9545-008-024	9545-008-024	AR
2	Cover-Control Box	9074-346-001	9074-346-001	9074-346-001	1
3	Screw-5/16, 10ABx3/8	9545-008-024	9545-008-024	9545-008-024	AR
4	Guard, RH	9208-093-001	9208-097-001	9208-101-001	1
*	Screw-5/16, 10ABx3/8	9545-008-024	9545-008-024	9545-008-024	AR
5	Guard Base & LH	9208-094-001	9208-098-001	9208-102-001	1
*	Screw-5/16, 10ABx3/8	9545-008-024	9545-008-024	9545-008-024	AR
6	Guard-Lower	9208-095-001	9208-099-002	9208-103-001	1
7	Screw-5/16, 10ABx3/8	9545-008-024	9545-008-024	9545-008-024	AR
8	Guard-upper	9208-096-001	9208-100-001	9208-104-001	1
*	Screw-5/16, 10ABx3/8	9545-008-024	9545-008-024	9545-008-024	AR
9	Elbow-90 degree, 8"	9142-039-001	9142-039-001	9142-039-001	1
10	Pipe-Duct, 8"	9109-121-001	9109-121-001	9109-121-002	1
11	Tee-Duct, Recirculation, 8"-6"	9810-018-001	9810-018-001	9810-019-001	1
12	Damper	9125-002-001	9125-002-001	9125-008-001	1
*	Pin-Damper, Hinge	9451-146-002	9451-146-002	9451-146-002	1
*	Nut-Spring	8520-141-000	8520-141-000	8520-141-000	2
13	Bracket-Recirculation Duct, Small	9029-228-001	9029-228-001	9028-228-001	1
14	Pipe-Duct, 6"	9109-122-001	9109-122-002	9109-122-003	1
15	Bracket-Duct, Recirculation Large	9029-246-001	9029-247-001	9029-247-001	1
16	Elbow-90 degree, 6"	9142-039-002	9142-039-002	9142-039-002	1
*	Booklet-Owners	8514-208-001	8514-208-001	8514-208-001	1
17	Diagram & Schematics	9506-474-001	9506-474-001	9506-474-001	1
18	Label-Warning & Notice	8502-600-001	8502-600-001	8502-600-001	1
19	Label-Instructions	8502-645-001	8502-645-001	8502-645-001	1
20	Decal-Lighting & Clearance	8527-151-001	8527-151-001	8527-151-001	1
21	Label-High Voltage	8502-614-004	8502-614-004	8502-614-004	1
*	8" Slide Open Clean Out Duct	9973-034-001	9973-034-001	9973-034-001	1

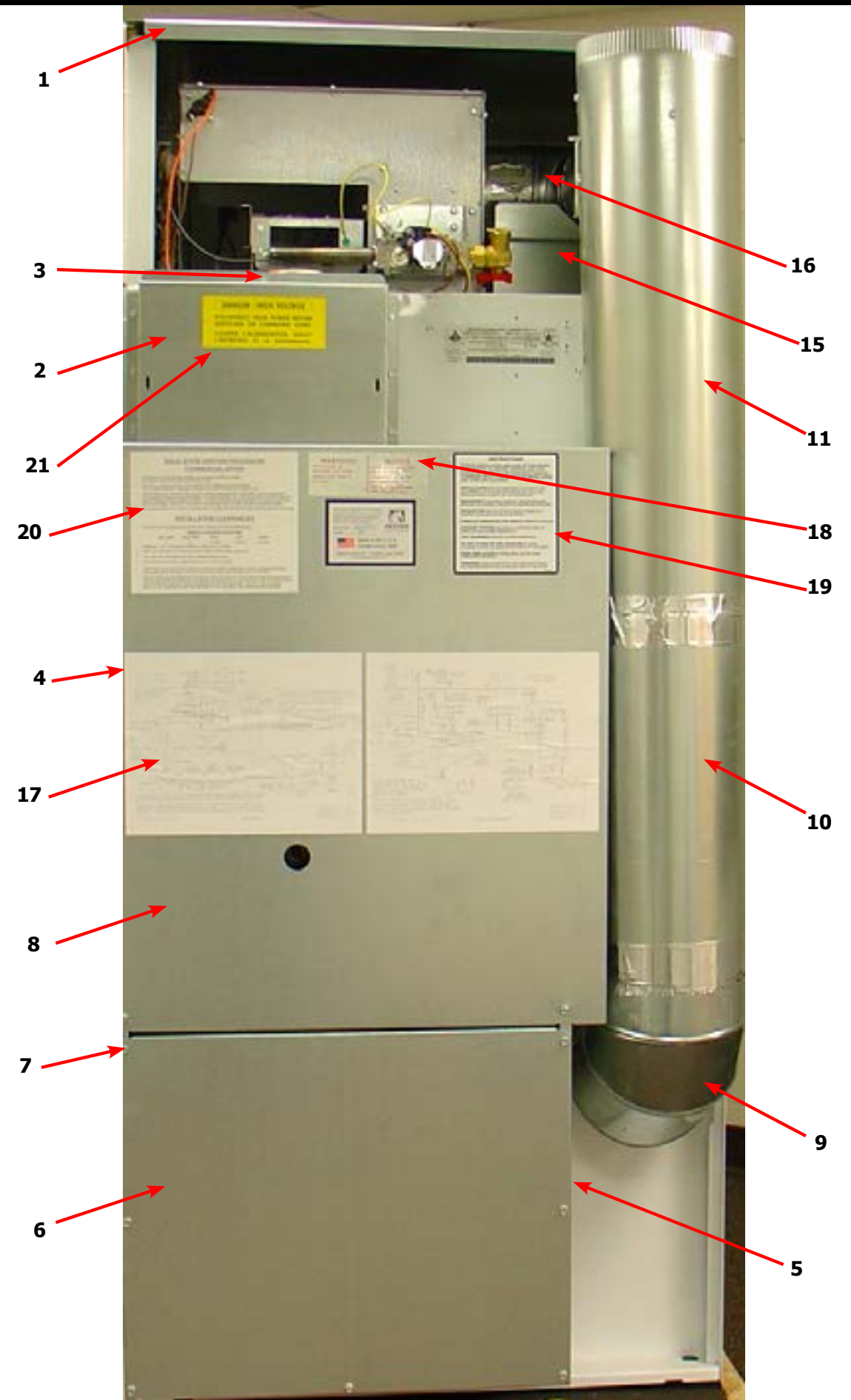
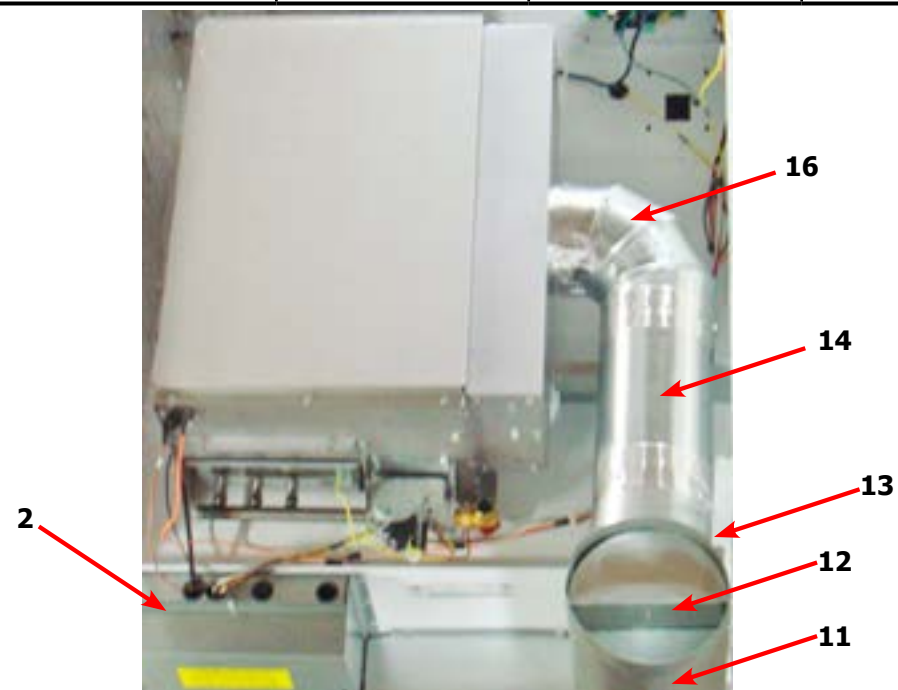

## Dryer Rear View-Bearing Housing 30Lb

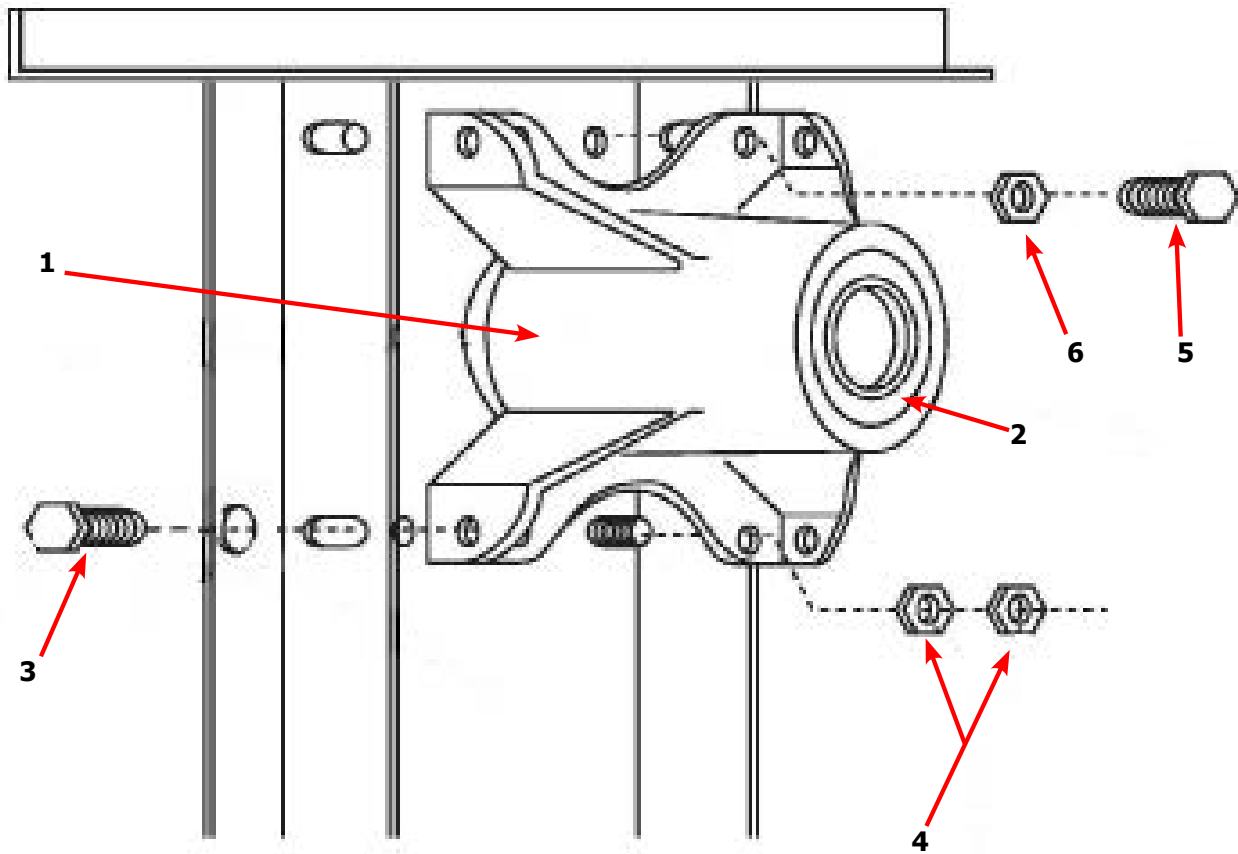

Key	Description	T-30	QTY
*	Bearing Housing Complete Assy (Includes bearings & Spacer)	9803-160-003	1
1	Housing, Bearing	9241-161-002	1
*	Bearing, Ball, Front	9036-130-001	1
*	Spacer, Bearing	9538-139-002	1
2	Bearing, Ball, Rear	9036-130-001	1
3	Screw-Wizlock, 3/8-24x3/4	9545-049-002	4
4	Nut, 5/16-18	8640-400-002	4
5	Screw, 3/8-24x1	9545-049-001	2
6	Nut, 3/8-24	8640-415-002	2
*	Shim, Tumbler	9538-139-002	AR

↓ Scroll down for  
50lb and 80lb  
Parts Breakdown

## Dryer Tumbler Group 30Lb

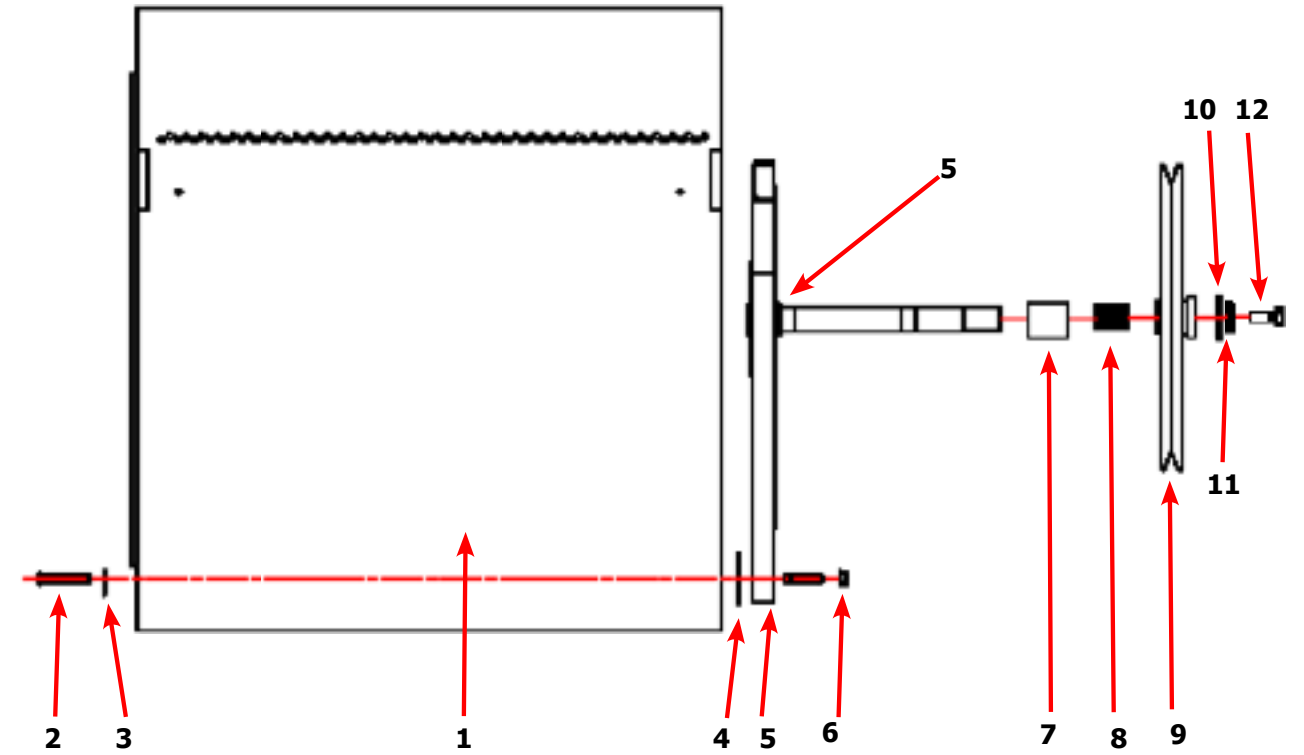

Key	Description	T-30	QTY
*	Tumbler Assy Complete W/Spider (GALV)	9848-142-001	1
1	Tumbler Assy (Galvanized)	9848-126-001	1
1	Tumbler Assy Complete W/Spider (SS & Galv front)	9848-142-002	1
1	Tumbler Assy (Stainless Galvanized front)	9848-126-002	1
2	Rod, Tumbler	9497-019-003	3
3	Washer, Special	8641-554-001	3
4	Shim	9552-013-003	AR
5	Spider Assy	9568-015-001	1
6	Nut, Wiz Lock	8640-415-004	3
7	Spacer-Shaft	9538-164-001	1
8	Tolerance Ring	9487-234-005	1
9	Pulley, Driven	9908-049-002	1
10	Washer -Flat	8641-581-026	1
11	LockWasher - IntTooth, 1"	8641-582-016	1
12	Screw, 1/2-13x1 1/4	9545-017-009	1

↓ Scroll down for  
50lb and 80lb  
Parts Breakdown



## Dryer Rear View-Bearing Housing 50Lb

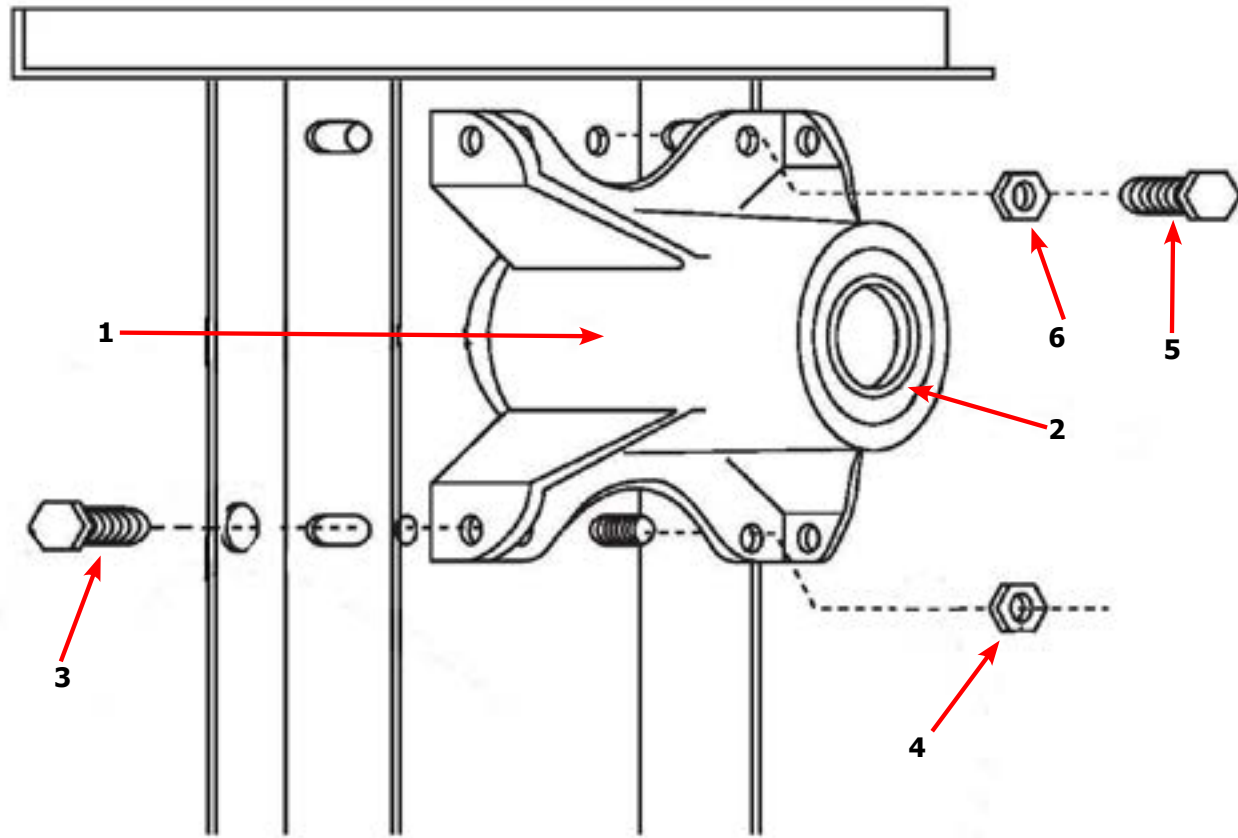

Key	Description	T-50	QTY
	Bearing Housing Complete Assy (Includes bearings & Spacer)	9803-201-001	1
1	Housing, Bearing	9241-189-002	1
*	Bearing, Ball, Front	9036-159-001	1
*	Spacer, Bearing	9538-183-001	1
2	Bearing, Ball, Rear	9036-159-003	1
3	Screw-Wizlock, 1/2-13x3/4	9545-017-017	4
4	Nut, 1/2-13	8640-417-002	2
5	Screw, 1/2-13x1 1/2	9545-017-018	2
6	Nut, 1/2-13	8640-417-002	2

↓ Scroll down for  
80lb Parts  
Breakdown

## Dryer Tumbler Group 50Lb

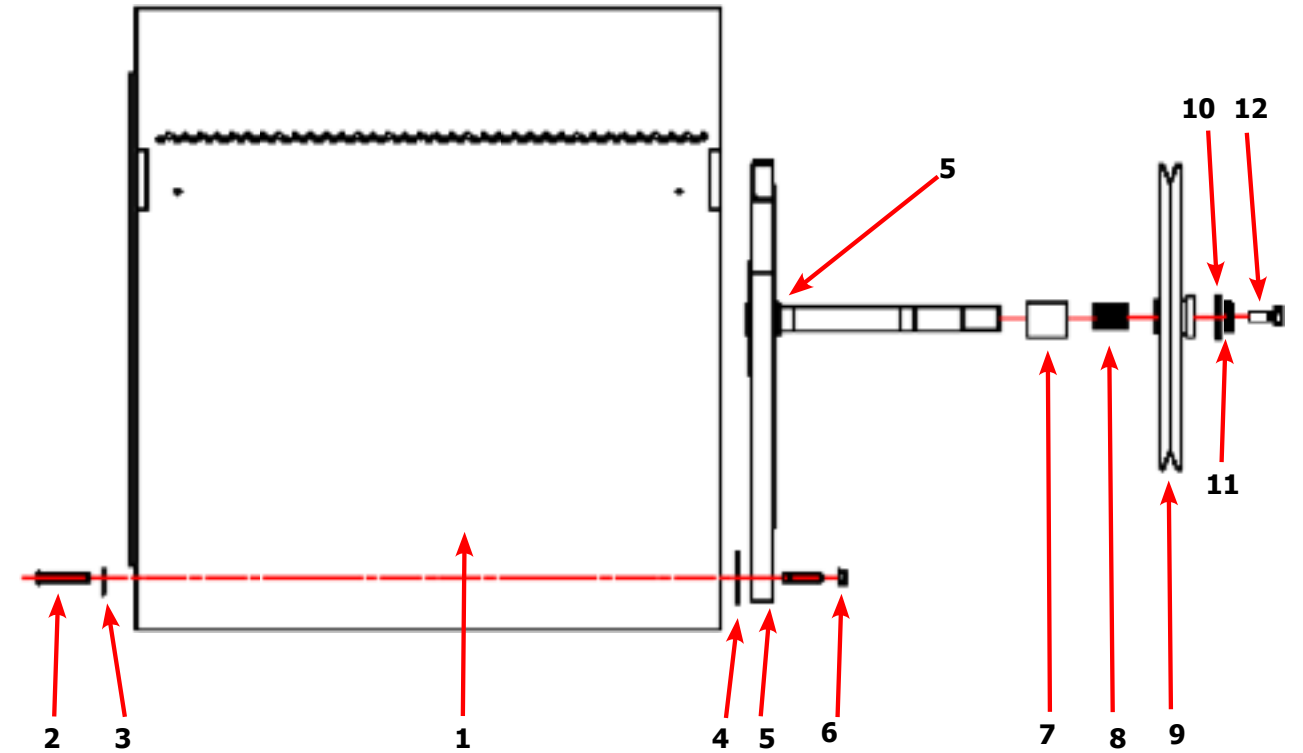

Key	Description	T-50	QTY
*	Tumbler Assy Complete W/Spider (GALV)	9848-131-001	1
1	Tumbler Assy (Galvanized)	9848-130-001	1
*	Tumbler Assy Complete W/Spider (SS & Galv front)	9848-131-002	1
1	Tumbler Assy (Stainless Galvanized front)	9848-130-002	1
2	Rod, Tumbler	9497-226-002	3
3	Washer, Special	8641-590-002	3
4	Shim	9552-013-000	AR
5	Spider Assy	9568-013-001	1
6	Nut, Wiz Lock	8640-417-005	3
7	Spacer-Shaft	9538-184-001	1
8	Tolerance Ring	9487-234-005	1
9	Pulley, Driven	9908-047-002	1
10	Washer -Flat	8641-581-026	1
11	LockWasher - IntTooth, 1"	8641-582-016	1
12	Screw, 1/2-13x1 1/4	9545-017-009	1

↓ Scroll down for  
80lb Parts  
Breakdown

## Dryer Rear View-Bearing Housing 80Lb

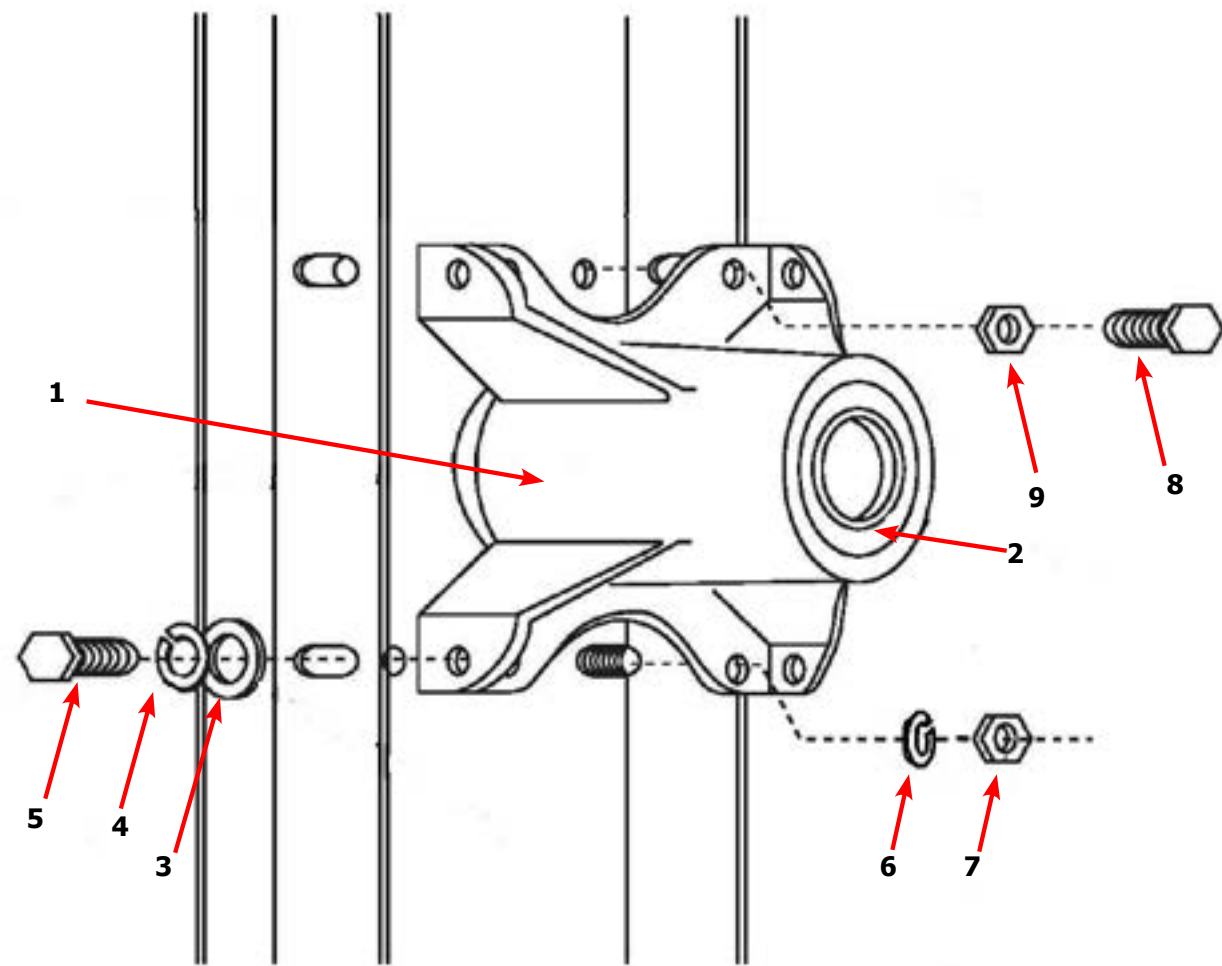

Key	Description	T80	QTY
	Bearing Housing Complete Assy (Includes bearings & Spacer)	9803-189-001	
1	Housing, Bearing	9241-183-003	
*	Bearing, Ball, Front	9036-159-001	
*	Spacer, Bearing		
2	Bearing, Ball, Rear	9036-159-002	
3	Washer, Flat 1/2	8641-581-026	
4	Lock Washer Spring, 1/2	8641-582-004	
5	Screw, 1/2-13x1	9545-017-004	
6	Lock Washer Spring, 1/2	8641-582-004	
7	Nut, 7/16-14	8640-416-001	
8	Screw, 7/16-14x1 1/2	9545-059-003	
9	Nut, 7/16-14	8641-416-001	

## Dryer Tumbler Group 80Lb

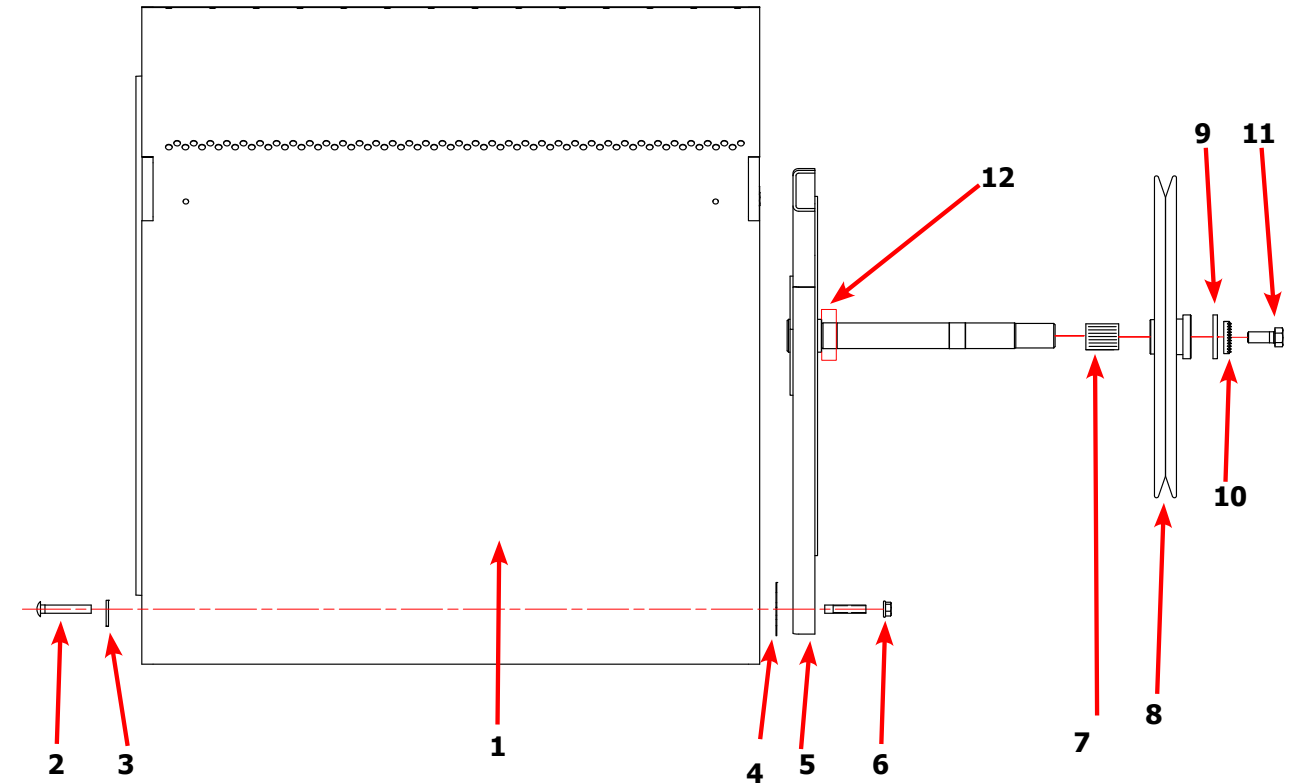

Key	Description	T80	QTY
*	Tumbler Assy Complete W/Spider (GALV)	9848-139-001	1
1	Tumbler Assy (Galvanized)	9848-138-001	1
1	Tumbler Assy Complete W/Spider (SS & Galv front)	9848-139-002	1
1	Tumbler Assy (Stainless Galvanized front)	9848-138-002	1
2	Rod, Tumbler	9497-266-001	4
3	Washer, Special	8641-590-001	4
4	Shim	9552-013-000	AR
5	Spider Assy w/Front Bearing	9873-008-001	1
6	Nut, Wiz Lock	8640-417-005	4
7	Tolerance Ring	9487-234-001	1
8	Pulley, Driven	9908-043-002	1
9	Washer -Flat	8641-581-026	1
10	LockWasher - IntTooth, 1"	8641-582-016	1
11	Screw, 1/2-13x1 1/4	9545-017-009	1
12	Bearing, Front	9036-159-002	1

# Dryer Burner Housing Group 30Lb

Key	Description	Part Number	Qty
*	Housing Assembly, Burner	9803-210-001	1
1	Panel-Burner Housing, Side Left	9454-845-001	1
2	Baffle-Burner Housing, Center	9049-091-001	1
3	Panel-Burner Housing, Top	9454-871-001	1
4	Panel-Burner Housing, Front	9454-847-001	1
5	Panel-Burner Housing, Back	9454-848-001	1
6	Baffle-Burner Housing, Recirculation	9049-092-001	1
7	Baffle-Burner Housing, Front	9049-093-001	1
8	Duct Adaptor, 6"x3" long	9109-120-01	1
9	Burner, Main	9048-021-001	2
10	Bracket-Support, Electrode	9029-214-001	1
11	Bracket-Support, Gas Valve	9029-227-001	1
12	Electrode-Ignition	9875-002-003	1
13	Control Assy, Gas Valve, White Rodgers 36J	9857-192-001	1
14	Manifold Assy	9381-009-007	1
15	Valve-Gas Shutoff, (Optional)	9379-196-001	1
16	Thermostat-HI-Limit	9576-203-002	
17	Screw, 10ABx3/8	9545-008-024	24
18	Screw, 10ABx1/4	9545-008-006	17
19	Orifice-Natural, .125	9425-069-023	2
*	Orifice-LP, #48	9425-069-003	2
*	Kit, LP Conversion, White Rodgers	9732-102-018	1
20	Bracket-Support, Burner	9029-225-001	1
21	Panel-Burner Housing, Side Right	9454-861-001	1
22	Screw, 10-32TTx1/2 Green	9545-008-027	3
23	Screw, 8-32x3/8	9545-010-014	4

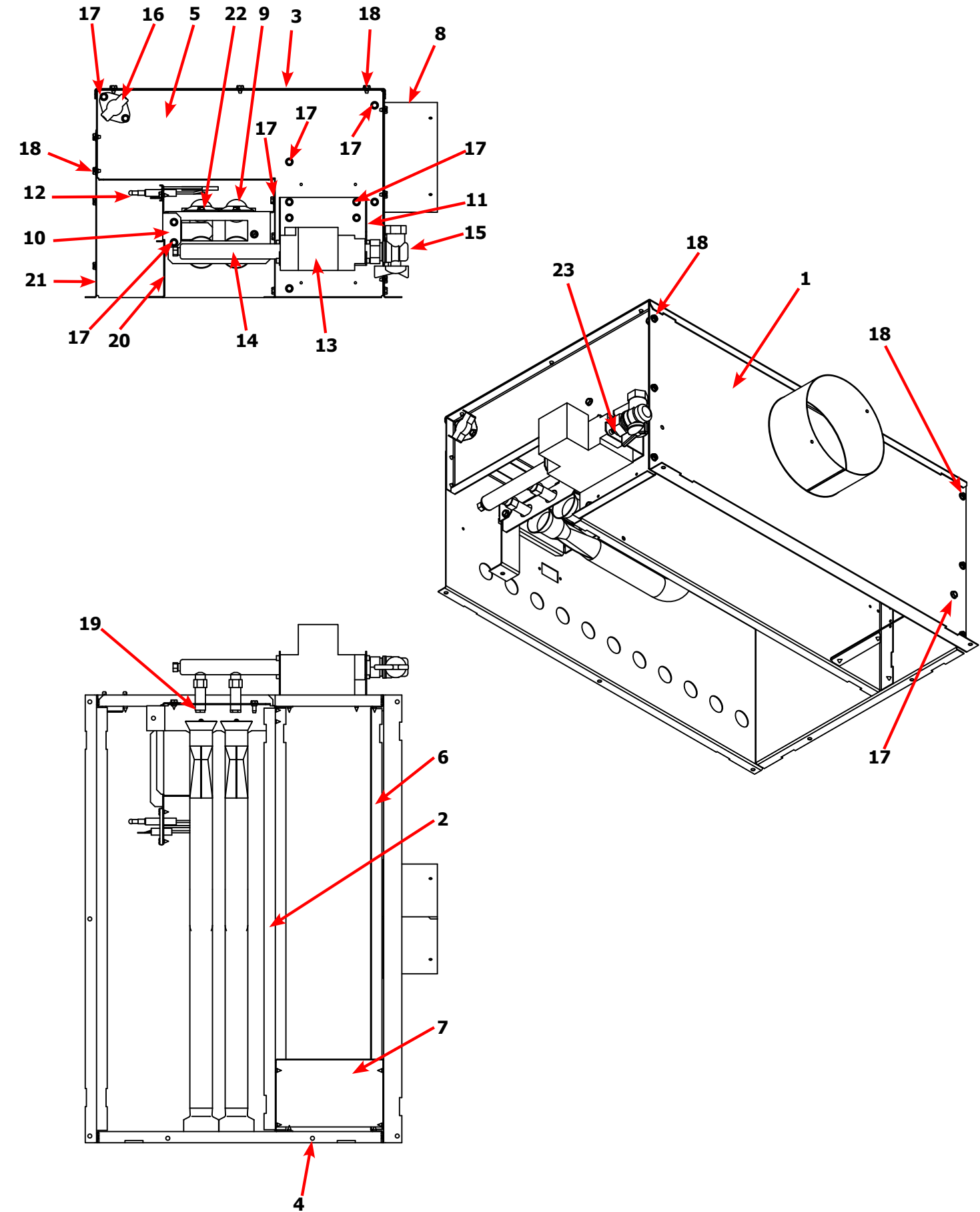



**Scroll down for  
50lb and 80lb  
Parts Breakdown**

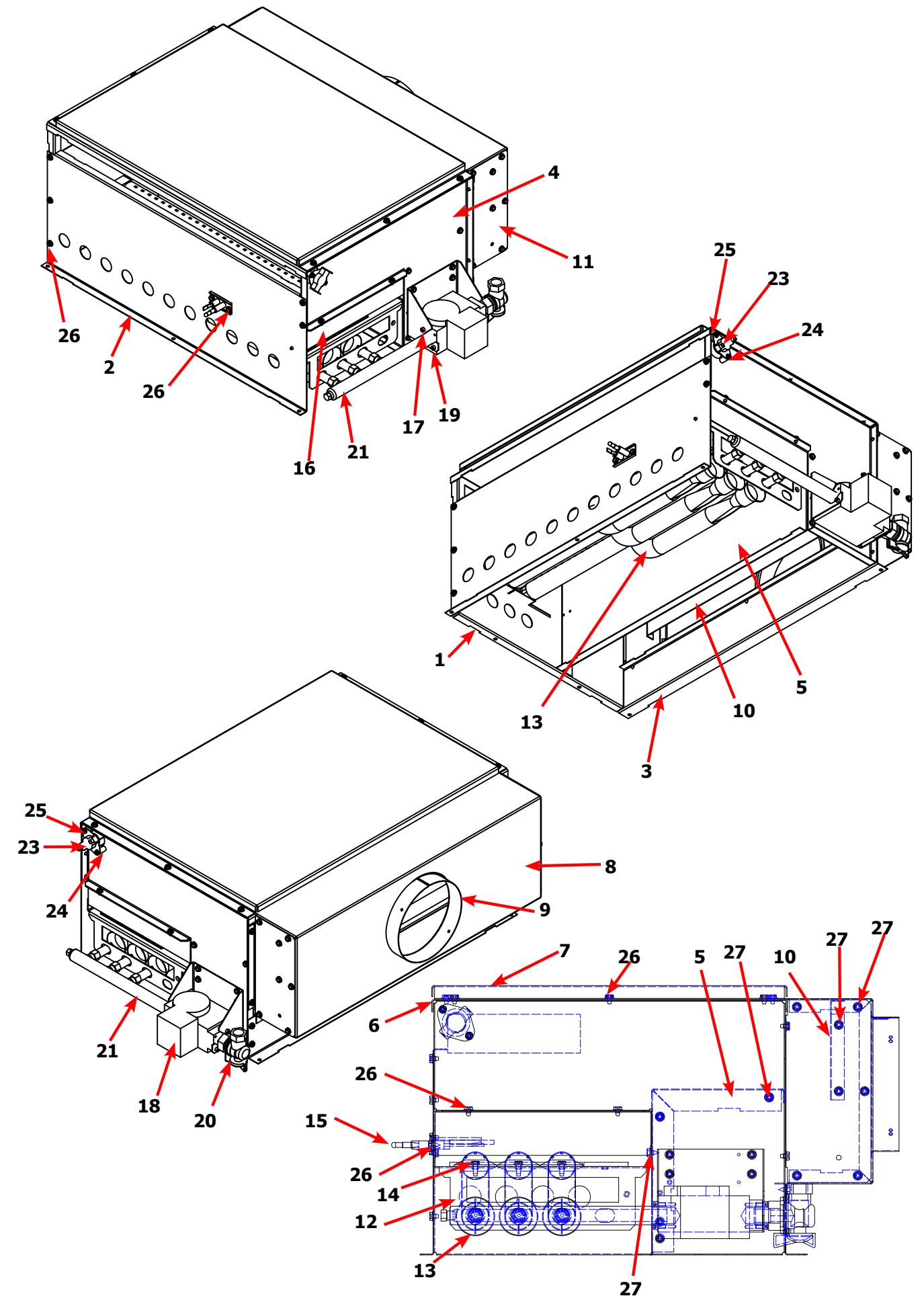

# Dryer Burner Housing Group 50Lb

Key	Description	Part Number	Qty
	Housing Assembly, Burner	9803-211-001	1
1	Panel-Burner Housing, Front	9454-863-001	1
2	Panel-Burner Housing, Side Right	9454-861-001	1
3	Panel-Burner Housing, Side Left	9454-862-001	1
4	Panel-Burner Housing, Back	9454-864-001	1
5	Baffle-Burner Housing, Center	9049-098-001	1
6	Panel-Burner Housing, Top	9454-849-001	1
7	Panel-Burner Housing, Top	9074-343-001	1
8	Baffle-Burner Housing, Extention	9049-100-001	1
9	Duct Adaptor, 6"x1.25" long	9109-120-003	1
10	Baffle-Burner Housing, Recirculation	9049-099-001	1
11	Side-Extention Baffle, Burner Housing	9551-049-001	2
12	Bracket-Support, Burner	9029-213-001	1
13	Burner, Main	9048-021-001	3
14	Screw, 10T-32x1/2	9545-008-008	3
15	Electrode-Ignition	9875-002-003	1
16	Cover-Burner, Intet	9074-344-001	1
17	Bracket-Support, Gas Valve	9029-227-001	1
18	Control Assy, Gas Valve, White Rodgers 36J	9857-192-001	1
19	Screw, #8-32x3/8	9545-010-014	4
20	Valve-Gas Shutoff, (Optional)	9379-196-001	1
21	Manifold Assy	9381-010-003	1
*	Orfice-Natural, #30	9425-069-002	3
*	Orfice-LP, #48	9425-069-003	3
*	Kit, LP Conversion, White Rodgers	9732-102-017	1
23	Thermostat-HI-Limit	9576-203-002	1
24	Spacer-1/4x5/8 long	9538-166-009	2
25	Screw-8Bx1	9545-045-013	2
26	Screw, 10Bx1/4	9545-008-001	22
27	Screw, 10ABx3/8	9545-008-024	31





**Scroll down for  
80lb Parts  
Breakdown**

# Dryer Burner Housing Group 80Lb

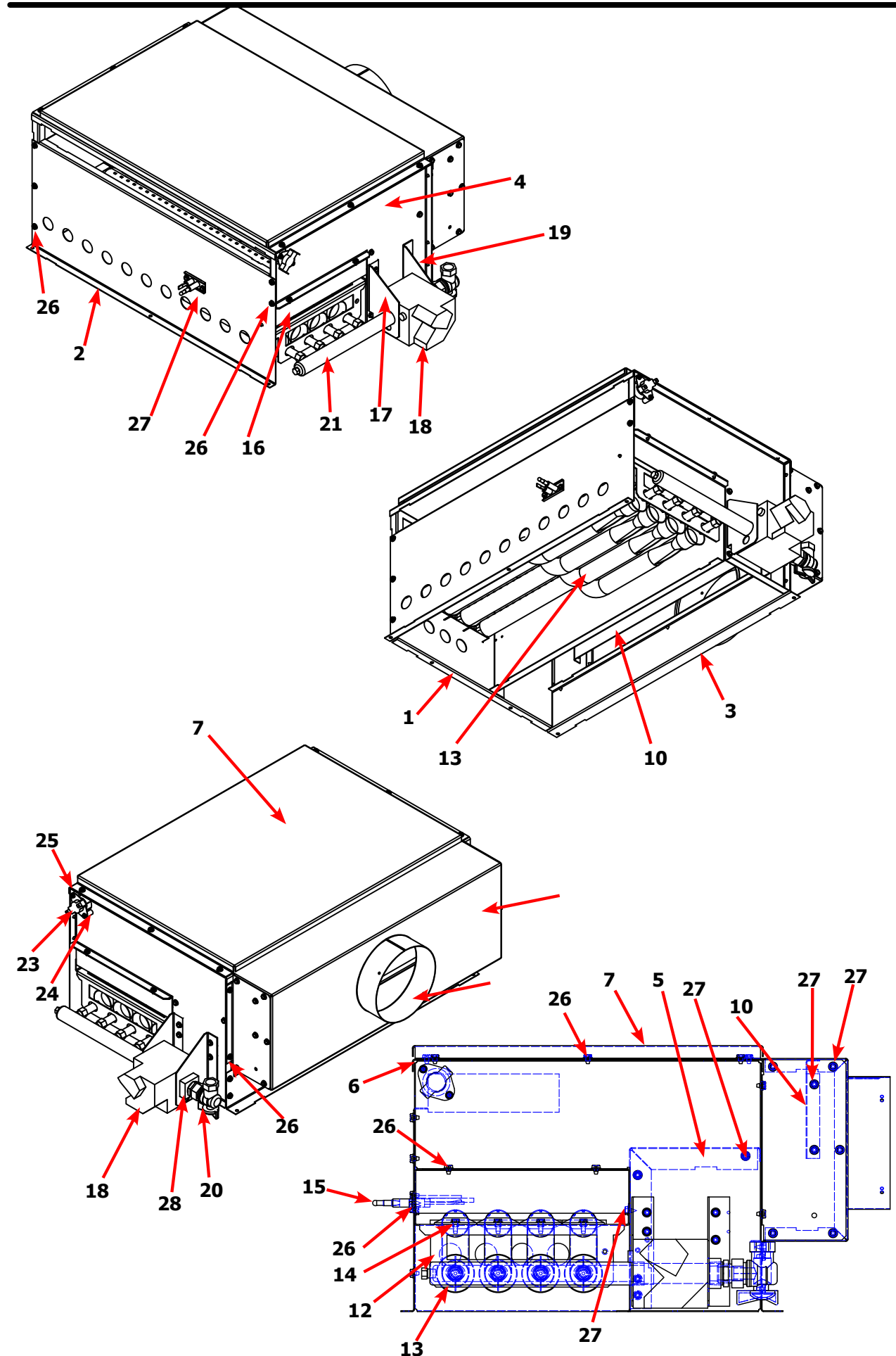
Key	Description	Part Number	Qty
	Housing Assembly, Burner	9803-212-001	1
1	Panel-Burner Housing, Front	9454-863-001	1
2	Panel-Burner Housing, Side Right	9454-861-001	1
3	Panel-Burner Housing, Side Left	9454-862-001	1
4	Panel-Burner Housing, Back	9454-864-001	1
5	Baffle-Burner Housing, Center	9049-098-001	1
6	Panel-Burner Housing, Top	9454-849-001	1
7	Panel-Burner Housing, Top	9074-343-001	1
8	Baffle-Burner Housing, Extention	9049-100-001	1
9	Duct Adaptor, 6"x1.25" long	9109-120-002	1
10	Baffle-Burner Housing, Recirculation	9049-099-001	1
11	Side-Extention Baffle, Burner Housing	9551-049-001	2
12	Bracket-Support, Burner	9029-213-001	1
13	Burner, Main	9048-021-001	4
14	Screw, 10T-32x1/2	9545-008-008	4
15	Electrode-Ignition	9875-002-003	1
16	Cover-Burner, Intet	9074-344-001	1
17	Bracket-Support, Gas Valve	9029-234-001	1
18	Control Assy,Gas Valve, White Rodgers 36J	9857-193-001	1
19	Bracket-support, Gas Valve Left hand	9029-235-001	4
20	Valve-Gas Shutoff, (Optional)	9379-196-001	1
21	Manifold Assy	9381-014-001	1
22	Orifice-Natural, #29	9425-069-021	3
*	Orifice-LP, #46	9425-069-022	3
*	Kit, LP Conversion, White Rodgers	9732-102-023	1
23	Thermostat-HI-Limit	9576-203-002	1
24	Spacer-1/4x5/8 long	9538-166-009	2
25	Screw-8Bx1	9545-045-013	2
26	Screw, 10Bx1/4	9545-008-001	22
27	Screw, 10ABx3/8	9545-008-024	31
28	Bushing-Reducer, 3/4x1/2	8615-104-009	1

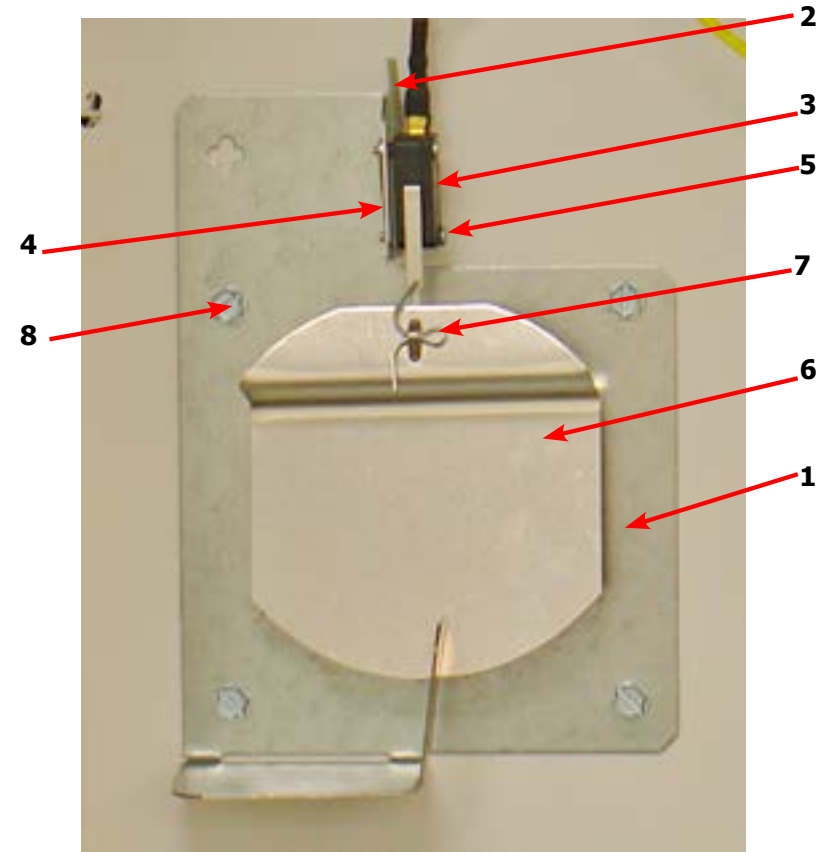



Key	Description	T-30	T-50	T80	QTY
*	Air Flow switch Assy	9801-095-002	9801-098-002	9801-098-002	1
1	Bracket-Airflow switch	9029-174-002	9029-200-002	9029-200-002	1
2	Shield-Switch	9550-169-003	9550-169-003	9550-169-003	1
3	Switch-Micro	9539-461-009	9539-461-009	9539-461-009	1
4	Nut-Twin, 4-40	8640-401-001	8640-401-001	8640-401-001	1
5	Screw-.625, 4-40	9545-020-001	9545-020-001	9545-020-001	2
6	Actuator-Air Flow Switch	9008-007-001	9008-007-001	9008-007-001	1
7	Pin-Cotter, .09375x.75	9451-169-002	9451-169-002	9451-169-002	1
	Screw, 10Bx1/4	9545-008-001			3
			9545-008-001	9545-008-001	4

## Electrical Box / Ignition Control

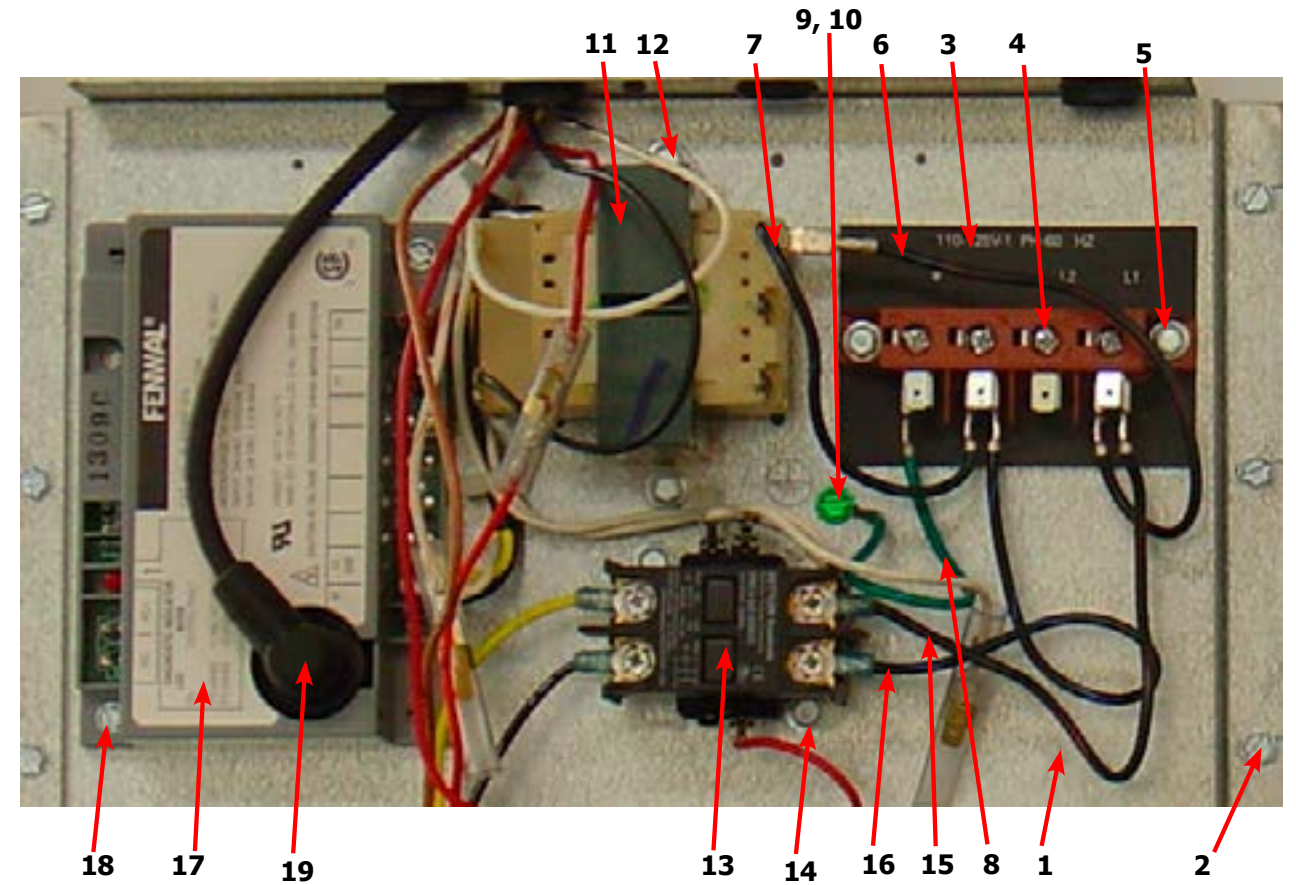

Key	Description	T-30	T-50	T80	QTY
1	Wrapper-Control Box	9636-200-001	9636-200-001	9636-200-001	1
2	Screw, 5/16-10AB-3/8	9545-008-001	9545-008-001	9545-008-001	6
*	Cover-Control Box	9074-346-001	9074-346-001	9074-346-001	1
*	Screw, 5/16-10AB-3/8	9545-008-024	9545-008-024	9545-008-024	1
3	Strip-Marker, Terminal	9558-029-005	9558-029-005	9558-029-005	1
4	Terminal Block Assy-Power, 4Pole	9897-035-001	9897-035-001	9897-035-001	1
5	Screw, 5/16-10AB-3/8	9545-008-024	9545-008-024	9545-008-024	2
6	Wire assy-Blk/Red, 6 1/2"	8220-001-230	8220-001-230	8220-001-230	1
7	Wire assy-Blk/Blu, 6 1/2"	8220-001-231	8220-001-231	8220-001-231	1
8	Wire Assy, GRN, 7"	8220-001-478	8220-001-478	8220-001-478	1
9	Screw- 10-32TTx1/2 GRN	9545-008-027	9545-008-027	9545-008-027	1
10	Lockwasher, External tooth	8641-582-006	8641-582-006	8641-582-006	1
11	Transformer, w/Circuit braker	8711-007-002	8711-007-002	8711-007-002	1
12	Screw, 5/16-10AB-3/8	9545-008-024	9545-008-024	9545-008-024	2
13	Relay-Motor, 30Amp, 24VAC	5192-299-002	5192-299-002	5192-299-002	1
14	Screw, 5/16-10AB-3/8	9545-008-024	9545-008-024	9545-008-024	2
15	Wire assy-Blk/Red, 9"	8220-146-001	8220-146-001	8220-146-001	1
16	Wire assy-Blk/Blu, 9"	8220-146-002	8220-146-002	8220-146-002	1
17	Control Assy, Ignition (Module)	9857-182-001	9857-182-001	9857-182-001	1
18	Screw-8Bx3/4"	9545-045-007	9545-045-007	9545-045-007	2
*	Harness, Ignition Module	9627-867-003	9627-867-003	9627-867-003	1
19	Wire Assy- High Voltage Lead	9631-403-009	9631-403-009	9631-403-009	1







DCBD30, 50, 80KC\_-64FN, 400V/3 Phase/50HZ 22KW

Key	Description	T-30	T-50	T80	
	Power-Block, 3 Pole	9897-037-001	9897-037-001	9897-037-001	1
	Power-Block, 1 Pole	9897-038-001	9897-038-001	9897-038-001	1
	Terminal marker	9558-032-001	9558-032-001	9558-032-001	1
	Terminal-Lug, Solderless	8652-134-002	8652-134-002	8652-134-002	1
	Screw-10-32TT x1/2 GRN	9545-008-027	9545-008-027	9545-008-027	1
	Wire Assy-BLK #1, 11"	8220-064-013	8220-064-013	8220-064-013	1
	Wire Assy-BLU #2, 11"	8220-064-061	8220-064-061	8220-064-061	1
	Wire Assy-BLK #13 8"	8220-057-016	8220-057-016	8220-057-016	3
	Line Filter-EMI	9183-030-001	9183-030-001	9183-030-001	1
	Transformer 250/24VAC	8711-008-002	8711-008-002	8711-008-002	1
	Wire Assy-BLK/RED, 17"	8220-150-003	8220-150-003	8220-150-003	1
	Wire Assy-BLK/BLU, #12, 12"	8220-151-002	8220-151-002	8220-151-002	1
	Wire Assy-BLK/RED, 11"	8220-147-001	8220-147-001	8220-147-001	1
	Wire Assy-BLK/BLU, 11"	8220-147-002	8220-147-002	8220-147-002	1
	Relay, R1-Motor Run	5192-299-002	5192-299-002	5192-299-002	1
	Wire Assy-WHT, 10"	8220-063-018	8220-063-018	8220-063-018	1
	Wire Assy-WHT 9"	8220-063-002	8220-063-002	8220-063-002	1
	Relay, R2-Heat relay	5192-285-004	5192-285-004	5192-285-004	1
	Wire Assy-BLK, 9"	8220-078-008	8220-078-008	8220-078-008	1
	Varistor-Coil Suppressor	9733-003-001	9733-003-001	9733-003-001	1
	Relay, Elements	5192-291-002	5192-291-002	5192-291-002	1
	Wire Assy-BLK, #33, 8"	8220-057-015	8220-057-015	8220-057-015	6
	Curcit Breaker, 3-Pole, 25AMP	5198-215-002	5198-215-002	5198-215-002	2
	Wire Assy-BLK, #34, 36"	8220-061-008	8220-061-008	8220-061-008	6
	Heating Elements, 12KW, 208V	9870-096-006	9870-096-006	9870-096-006	2
	Jumper-Formed	9295-006-001	9295-006-001	9295-006-001	2

ELECTRICAL PROPERTIES

MODEL	**A	Z kW	R1-R3 & R4-R6	Q1 & Q2	K6
FN	25A	22kW	9870-096-006	5198-215-002	5192-291-002
FP	32A	28kW	9870-096-005	5198-215-003	5192-296-002
FQ	32A	33kW	9870-096-004	5198-215-003	5192-296-002

INFORMATIVE 6102-018-173

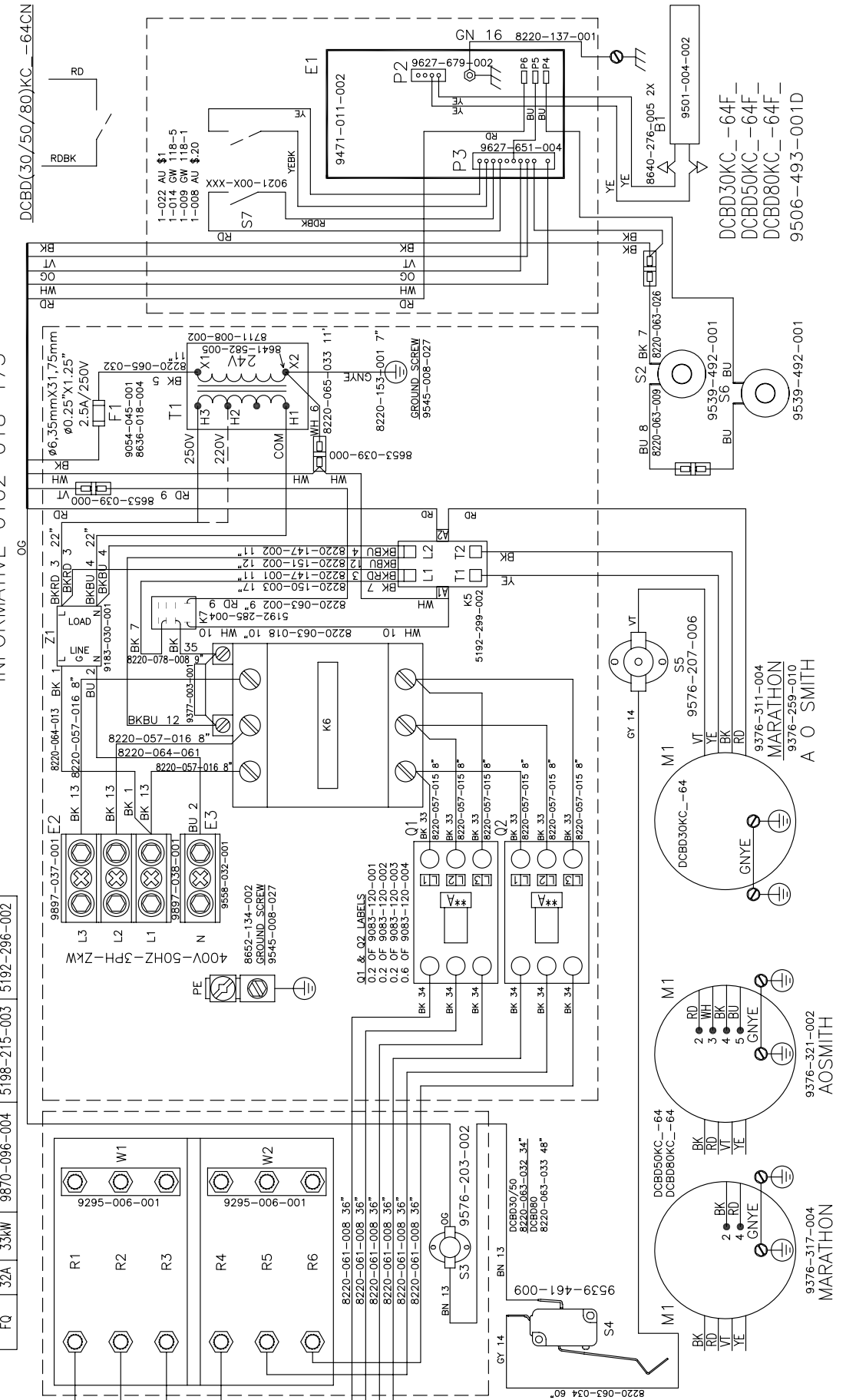



---

**Notes**

Lined area for notes on page 40.

---

**Section 7:**

50Hz

Dryer Parts Data

DCBD30.50.80KC\_-39 230VAC 1 PH 50Hz

Key	Description	T-30	T-50	T80	QTY
	Motor	9376-311-004	9376-317-004	9376-317-004	1
	Pulley	9453-169-009	9435-169-014	9453-169-009	1
	Strip Terminal Marker	9558-029-004	9558-029-004	9558-029-004	1
	Wiring Label-Schematic/Diagram	9506-496-001	9506-496-001	9506-496-001	1
	Switch Assembly-Air flow	9801-095-002			
	Bracket-Airflow switch	9029-174-002			
	Switch Micro	9539-461-009			
	Orifice Main Burner, #32	9425-069-009			2
	Orifice Main Burner, #32		9425-069-009		3
	Orifice Main Burner, #30			9425-069-002	4
	LP Kit	9732-102-019	9732-102-021	9732-102-022	1
	Overlay-Trim Lower door	9435-016-004	9435-016-005	9435-016-005	1

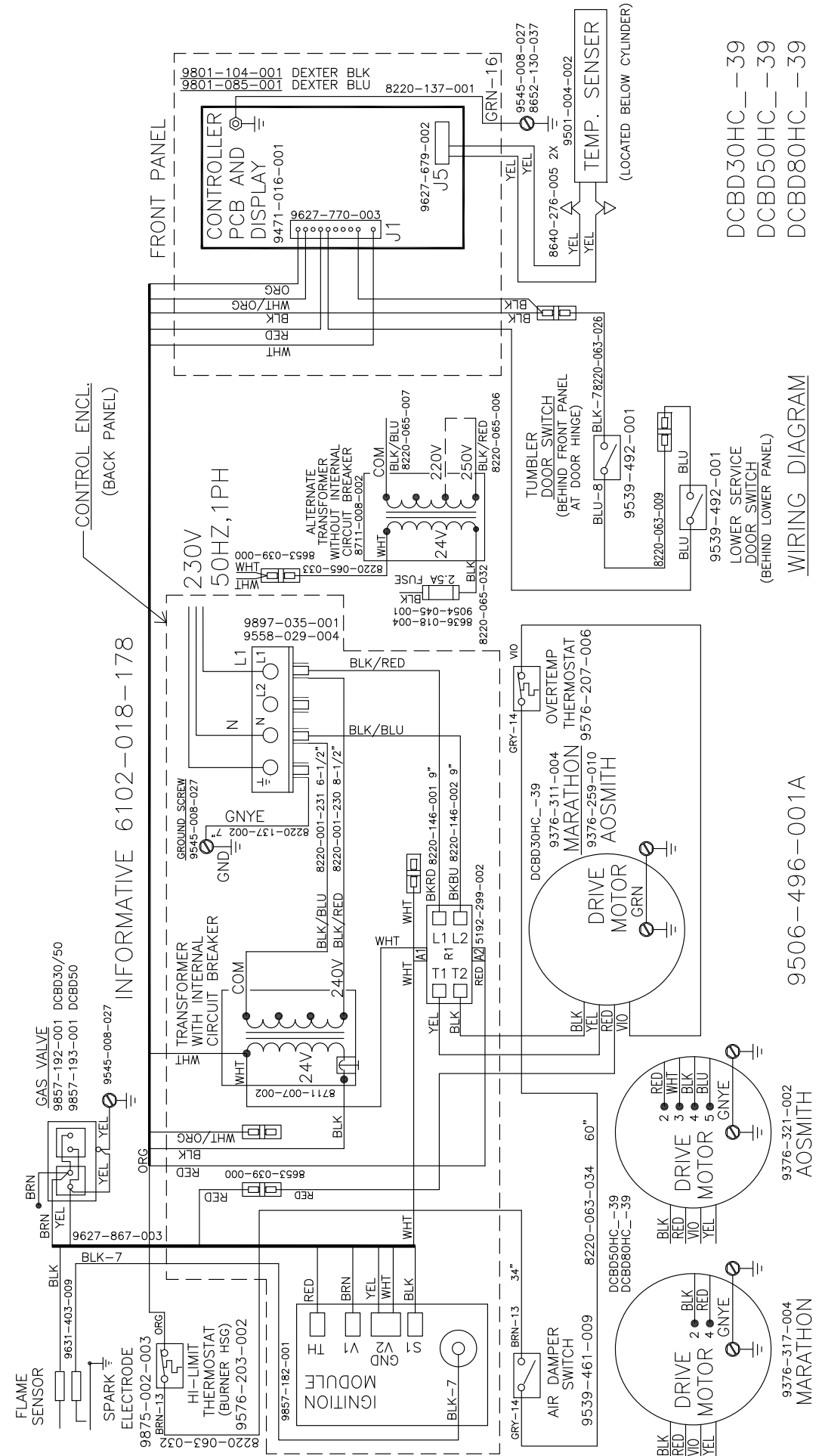

DCBD30HC\_-39  
 DCBD50HC\_-39  
 DCBD80HC\_-39

WIRING DIAGRAM  
 (BEHIND LOWER PANEL)

9506-496-001A