



DEXTER[®]
LAUNDRY

**USE THE BLUE TABS LOCATED ON THE
RIGHT AND LEFT SIDES OF THE FOLLOWING
DOCUMENT TO ADVANCE TO EACH SECTION.**

Wiring Harness Group by Part #

Key	Part Number	Description	Qty
*	9627-688-001	Wiring Harness, Power Term Blk	1
*	9627-690-001	VF Power Drive	1
*	9627-692-001	Wiring Harness, Main	1
*	9627-694-001	Wiring Harness, Control	1
*	9627-693-001	Wiring Harness, VF Control Shield	1
*	9627-691-001	Wiring Harness, Injection Control	1
*	9627-683-001	Wiring Harness, Drain Valve	1
*	8654-125-001	Clamp, Cable- 1/4 Dia	1

* Not Illustrated

Section 6:

Parts Data
N-Series On-Premise
Large Chassis

Models
WCN55AEH

Cabinet and Front Panel Group by Part

Key	Part Number	Description	
1	9454-672-001	Panel, Side (Left or Right)Stainless	4
*	9545-018-013	Screw, Side to Side	8
*	8640-414-006	Nut, Keps	8
2	9966-012-001	Strap Assy, Side Panel	4
2	8640-414-006	Nut	8
3	9454-671-002	Panel Assy, Front	1
4	9059-063-002	Band, Edge Protector	1
*	9545-008-024	Screw, Hex- To Control Panel.	2
*	8640-399-005	Nut, Spring- To Control Panel	2
5	9545-008-014	Screw, Flat Head- Front to Sides	2
5	8641-585-001	Washer, Finish	2
*	8640-399-008	Nut, Spring- To Control Panel	2
*	9545-008-023	Screw, Fillister Head Guide	2
6	8502-624-002	Label, Door Opening	1
7	9989-454-001	Panel, Control (Mounts Nameplate)	1
*	9545-008-024	Screw, Control Panel Mtg to front	2
*	8640-399-005	Nut, Spring	2
*	9545-008-026	Screw, Hex Wshr-Control Panel to Sides	4
8	9412-092-001	Nameplate, Control Panel	1
*	9355-001-001	Locator, Panel	1
*	9545-008-025	Screw, #10	1
9	9454-673-001	Panel, Top	1
10	8650-012-003	Lock, Top(w/Key)	2
*	9306-025-001	Key, Top-6324	1
*	9095-038-001	Cam, Lock Top	2
*	8640-426-001	Nut, 9/32	2
*	8641-581-008	Washer, Flat	2
11	9108-099-001	Door, Lower Service	1
*	9244-081-003	Handle (bumper guard)	1
*	9545-045-010	Screw	1
*	9545-008-023	Screw, Fillister Head Guide	2
12	9545-008-014	Screw, Flat Head	2
12	8641-585-001	Washer, Finish	2
*	8640-399-008	Nut, Spring	2
13	9108-095-003	Door, Dispenser	1
*	9451-191-001	Pin, Plain	2
*	9467-025-001	Post, Door Mounting	2
*	9545-045-002	Screw, Dispenser Post Mtg	4
*	9545-008-012	Screw, Dispenser Mounting	4
*	8640-399-007	Nut, Spring	4

* Not Illustrated

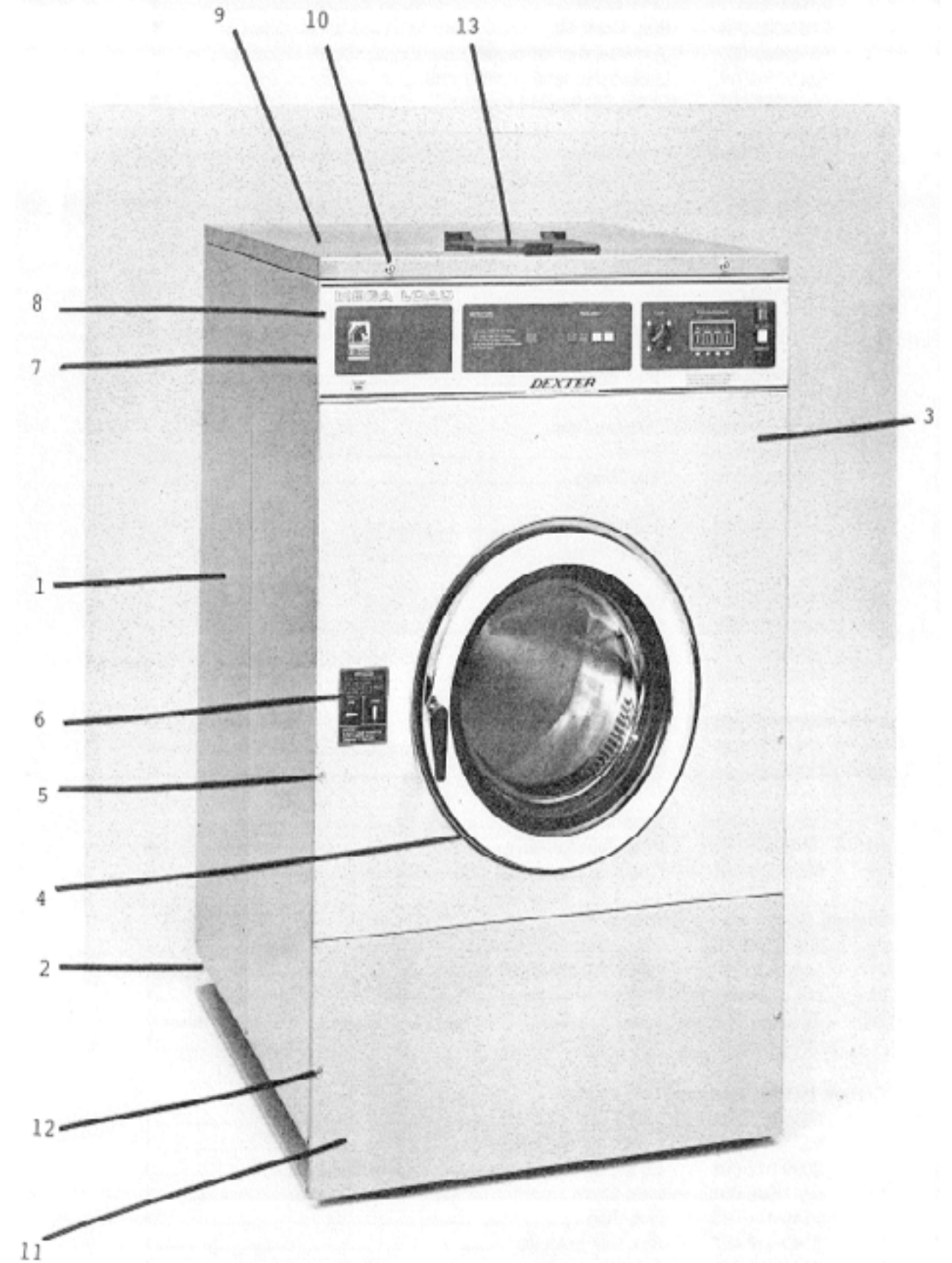

Rear View Access by Part

Key	Part Number	Description	Qty
1	9376-298-001	Drive Motor	1
2	9497-222-004	Rod, Motor Mtg	1
*	9545-029-005	Screw (end of motor rod)	1
*	8641-582-014	Lockwasher (end of motor rod)	1
3	9076-052-002	Collar, Shaft (w/set screws)	2
4	9453-175-002	Pulley, Motor	1
5	9053-077-001	Bushing, SplitTaper	1
6	9545-018-021	Screw	3
7	9453-176-001	Pulley, Driven	1
8	9053-076-001	Bushing, Taper	1
9	9545-029-011	Screw	3
9	8641-582-003	Lockwasher	3
10	9040-079-002	Drive Belt (double wide)	1
11	9081-109-001	Channel, Rear	1
12	9545-008-026	Screw	4
*	8640-399-004	Nut, Spring	4
13	9242-449-003	Hose, Overflow	1
14	8654-029-000	Clamp, Hose	2
*	9989-455-001	Panel Assy., Back	1
15	9545-030-002	Screw, To Base	4
*	9545-008-026	Screw	14
*	8640-399-004	Nut, Spring	10
*	9242-175-004	Hose, Pressure Switch	1
*	8654-117-015	Clamp, Pressure Sw. Hose	1
16	5198-211-004	Circuit Breaker, 1.5 amp	1
17	9883-005-001	Injector Assy	1
18	9242-461-001	Hose, Injector Assy	2
19	8654-117-001	Clamp	4
Original Motor Tensioner			
20	9029-027-004	Strap, Motor Tension	1
21	8640-413-002	Nut, Strap to Motor	1
21	8641-581-006	Washer	1
22	9545-018-020	Screw 1/4x3	1
*	8640-414-003	Nut, Elastic Stop	1
New Motor Tensioner (not pictured)			
*	9545-055-001	Bolt, Eye	1
*	9534-151-000	Spring, Belt Tension	1
*	9099-012-001	Chain, Spring Tension	1
*	9341-046-001	Link, Chain	1
*	8640-414-003	Nut, Stop	1
*	8640-413-002	Nut, Link to Motor	1
*	8641-581-006	Washer	1

*Not illustrated

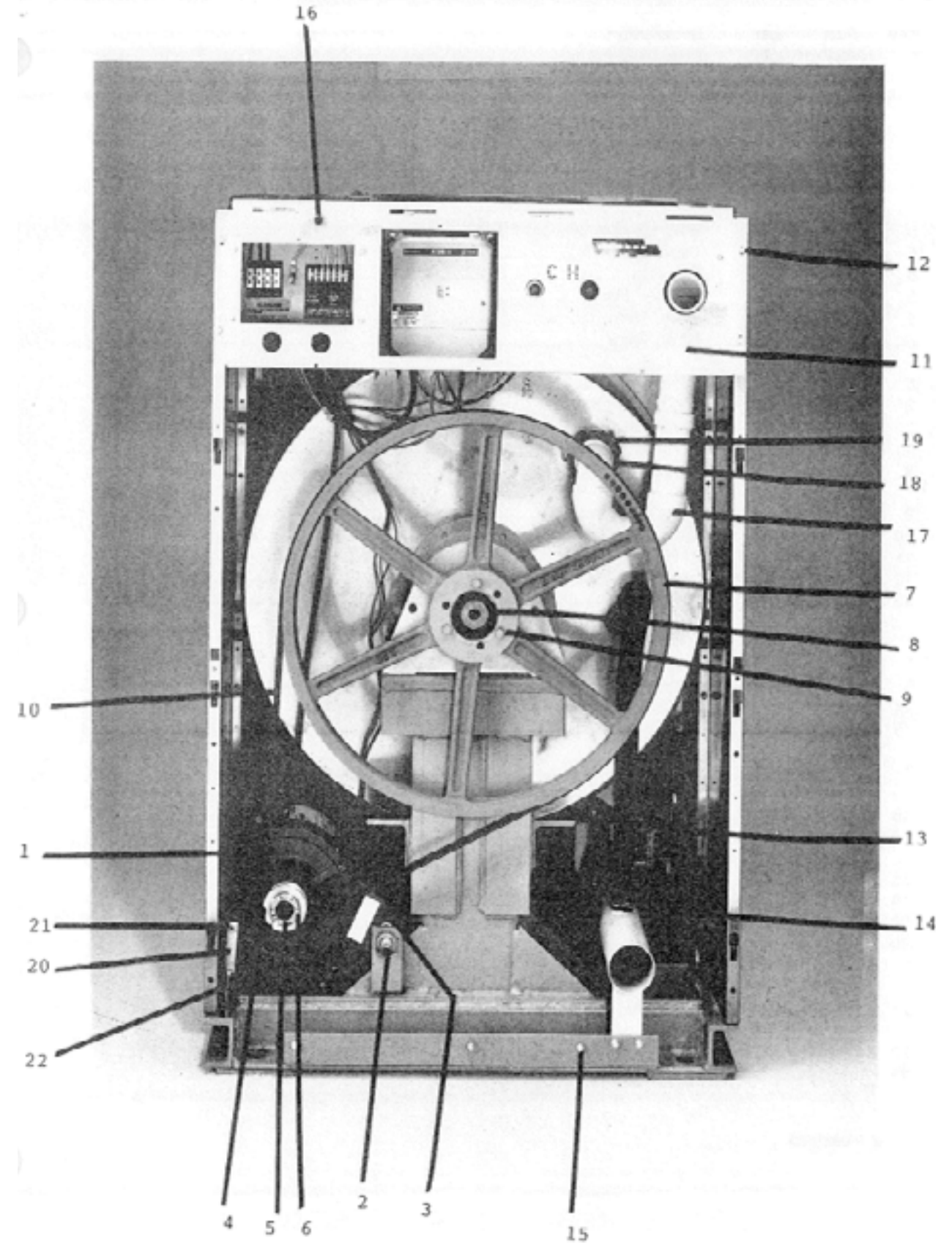

Cylinder, Seals & Bearings by Part

Key	Part Number	Description	Qty
1	9848-116-001	Cylinder, Assy	1
*	9456-041-006	Plug, Cylinder (inside)	1
*	9803-187-001	Housing, Bearing- Assembly (includes items #2-#6)	1
2	9241-181-004	Housing, Bearing	1
3	9036-159-006	Bearing, Rear	1
4	9036-159-005	Bearing, Front	1
5	9538-170-001	Spacer, Bearing	1
6	9487-238-004	Ring-Retainer, Internal	1
7	9545-057-002	Screw, Bearing Housing to Frame, 3/4	6
7	8641-581-033	Washer, Flat- To Frame	6
7	8641-582-020	Washer, External Tooth	6
7	8640-418-003	Nut	6
8	9532-140-008	Seal, Secondary	1
9	9532-140-007	Seal, Primary	1
10	9950-052-001	Ring, Seal Mtg	1
11	9950-054-004	Ring, Seal Tub Back	1
12	9545-059-004	Screw, 7/16 Tub Back to Bearing Housing	6
12	8641-581-034	Washer, Flat	6
13	9453-176-005	Pulley, Driven	1
14	9053-078-002	Bushing, Taper	1
15	9545-029-011	Screw	3
15	8641-582-003	lockwasher	3
16	9242-461-001	Hose, Injector Assy	1
17	8654-117-001	Clamp	2

* Not Illustrated

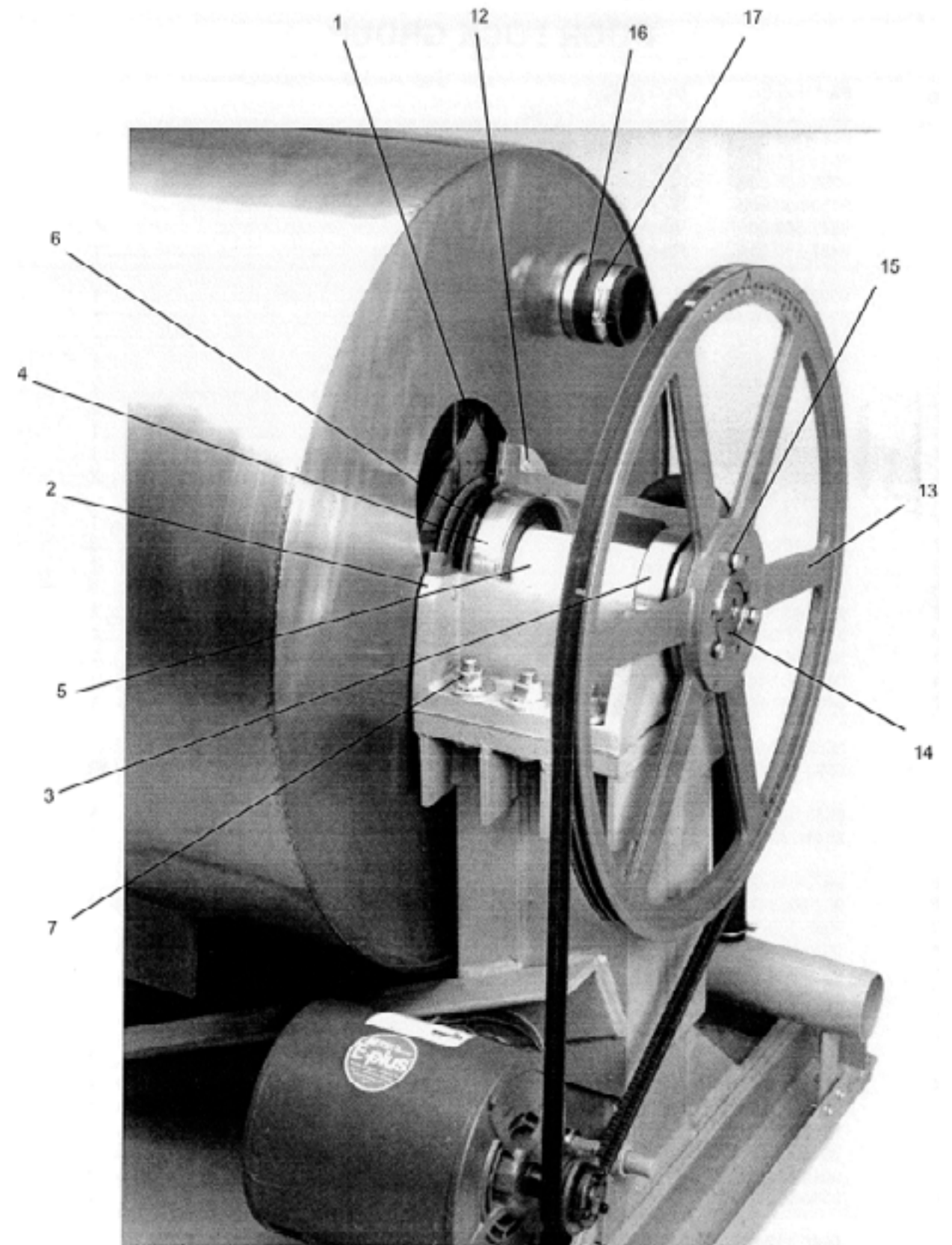
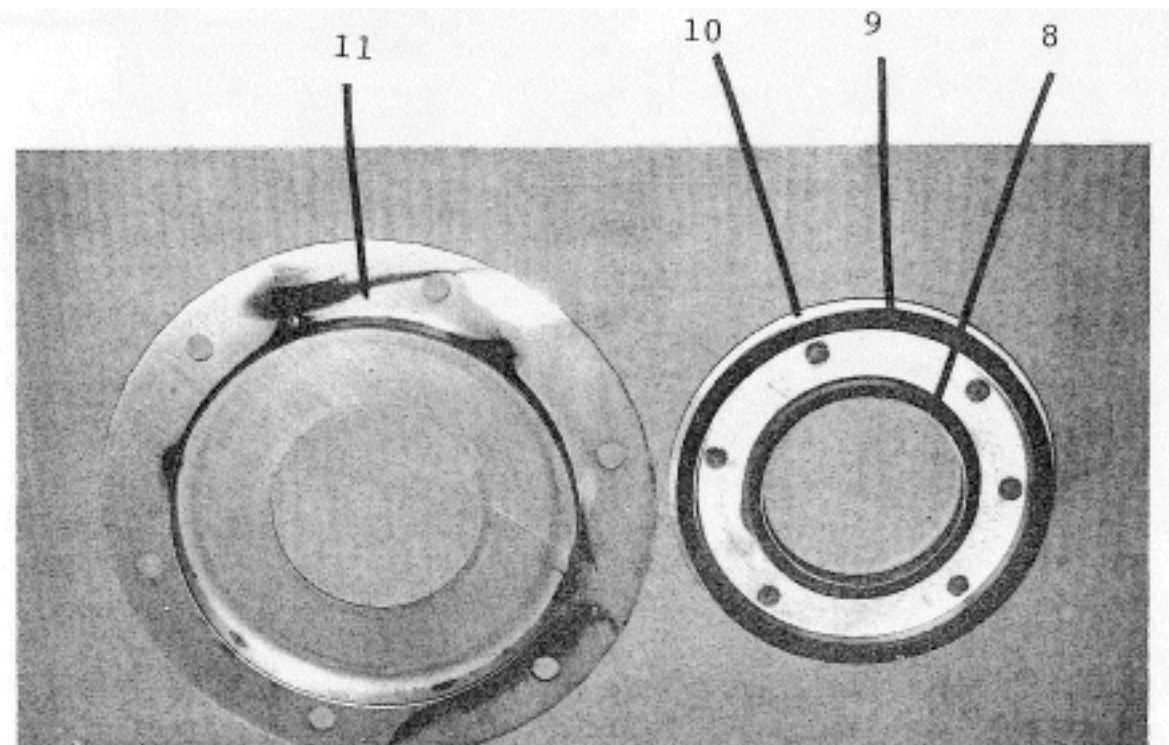

Door Latching & Solenoid Door Lock Assemblies by Part

Key	Part Number	Description	Qty
*	9885-023-001	LockAssy, Complete (includes #1 thru #22)	1
1	9982-284-001	Plate Assy, Door Lock	1
2	8641-581-030	Washer, Flat	1
3	9008-005-001	Actuator, Latching Switch	1
4	9450-002-002	Pawl, Locking	1
5	8641-569-003	Washer, Spring	1
6	9487-200-004	Ring, Ret Jning	1
7	9029-035-001	Bracket; SOWiitch	1
8	8640-413-002	Nut, Hex 10-32 UNF	2
9	9534-364-001	Spring, Actuating	2
10	9545-012-020	Screw, Hx. 10-32 x 1	1
11	8640-413-004	Nut, E.lastic Stop 10-32	2
12	9534-364-002	Spring, Return	1
13	9451-193-001	Pin, Guide	1
14	9487-200-005	Ring, Retaining	1
15	8641-581-031	Washer	2
16	9539-461-008	Switch, Latching Sensing	1
17	9550-169-003	Shield, Switch	3
18	9545-020-001	Screw 4-40 x 5/8	2
18	8640-401-001	Nut, Twin	1
19	9539-461-007	Switch, Locking Sensing	2
20	9008-006-002	Actuator, Switch	2
21	9545-020-003	Screw 4-40 x 1 1/8	2
21	8640-401-001	Nut, Twin 4-40	1
22	9451-181-004	Pin, Dowel	1
*	9552-037-001	Shim, Door Lock, Thin	AR
*	9552-037-002	Shim, Door Lock, Thick	AR
*	9545-018-014	Screw, Lock mtg 1/4 -20 x 3/4	3
*	8641-582-007	Lockwasher 1/4 Ext tooth	3
*	9922-011-001	Solenoid Ass'y, Door Locking (includes 23 thru 32)	1
23	9029-073-001	Bracket, {Door Locking Solenoid)	1
24	9985-169-001	BracketAss'y, Soienoid Slide	1
25	9536-074-001	Solenoid 120V 60 hz	1
26	9545-008-001	Screw, Solenoid Mtg	4
27	9540-033-002	Stop, Door Lock Solenoid	1
28	9545-061-001	Screw, Shoulder	1
28	8640-411-003	Nut, Keps #6	1
29	9586-001-001	Thermoactuator 120 V	2
30	9545-031-011	Screw. #6 x5/16	4
31	9538-157-004	Spacer, Plastic	1
31	9538-166-004	Spacer, Metal	1
31	9545-010-001	Screw, Cross Recessed	1
31	8640-412-005	Nut, Keps #8	1
32	8640-411-002	Nut, Keps#6	1
*	8640-412-005	Nut, Sol.Brkt. to Control. Panel	3
*	9497-225-006	Rod, Pull	1

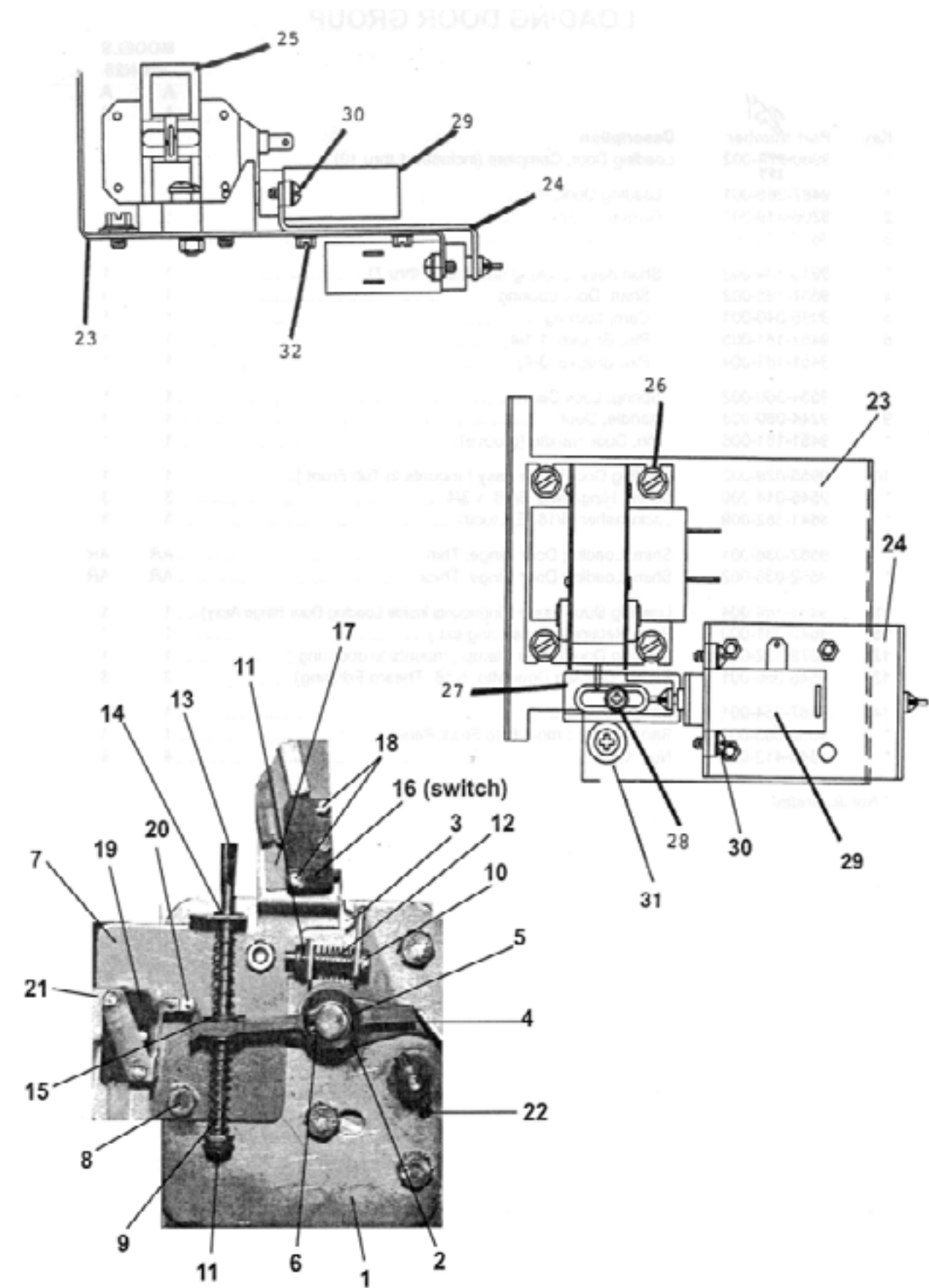

Loading Door Part # by Model

Key	Part Number	Description	Qty
*	9960-259-002	Loading Door, Complete (includes 1 thru 9)	1
1	9487-230-001	Loading Door, Ring	1
2	9206-419-001	Gasket, Loading Door	1
3	9635-016-001	Window, Loading Door	1
*	9913-134-003	Shaft Assy, Locking includes (4 thru 7)	1
4	9537-195-002	Shaft, Door Locking	1
5	9095-040-001	Cam, Locking	1
6	9451-181-005	Pin, Groove (1 1/4)	1
7	9451-181-004	Pin, Groove (3/4)	1
8	9534-360-002	Spring, Lock Cam	1
9	9244-080-003	Handle, Door	1
*	9451-181-006	Pin, Door Handle (groove)	1
10	9955-029-001	Hinge Assy, Loading Door	1
*	9545-014-009	Screw, Hinge Mtg	3
*	8641-582-009	Lockwasher	3
*	9552-036-001	Shim, Loading Door Hinge, Thin	AR
*	9552-036-002	Shim, Loading Door Hinge, Thick	AR
11	9451-184-003	Pin, Loading Door Hinge	1
*	8649-031-000	Ring, Retaining	1
12	9079-122-002	Clamp, Loading Door Hinge Pin	1
13	9545-056-001	Screw, Loading Door Mtg	3
14	9487-254-001	Ring, Masking	1
*	9059-063-002	Band, Edge	1
*	8640-413-002	Nut, Keps	4

* Not Illustrated

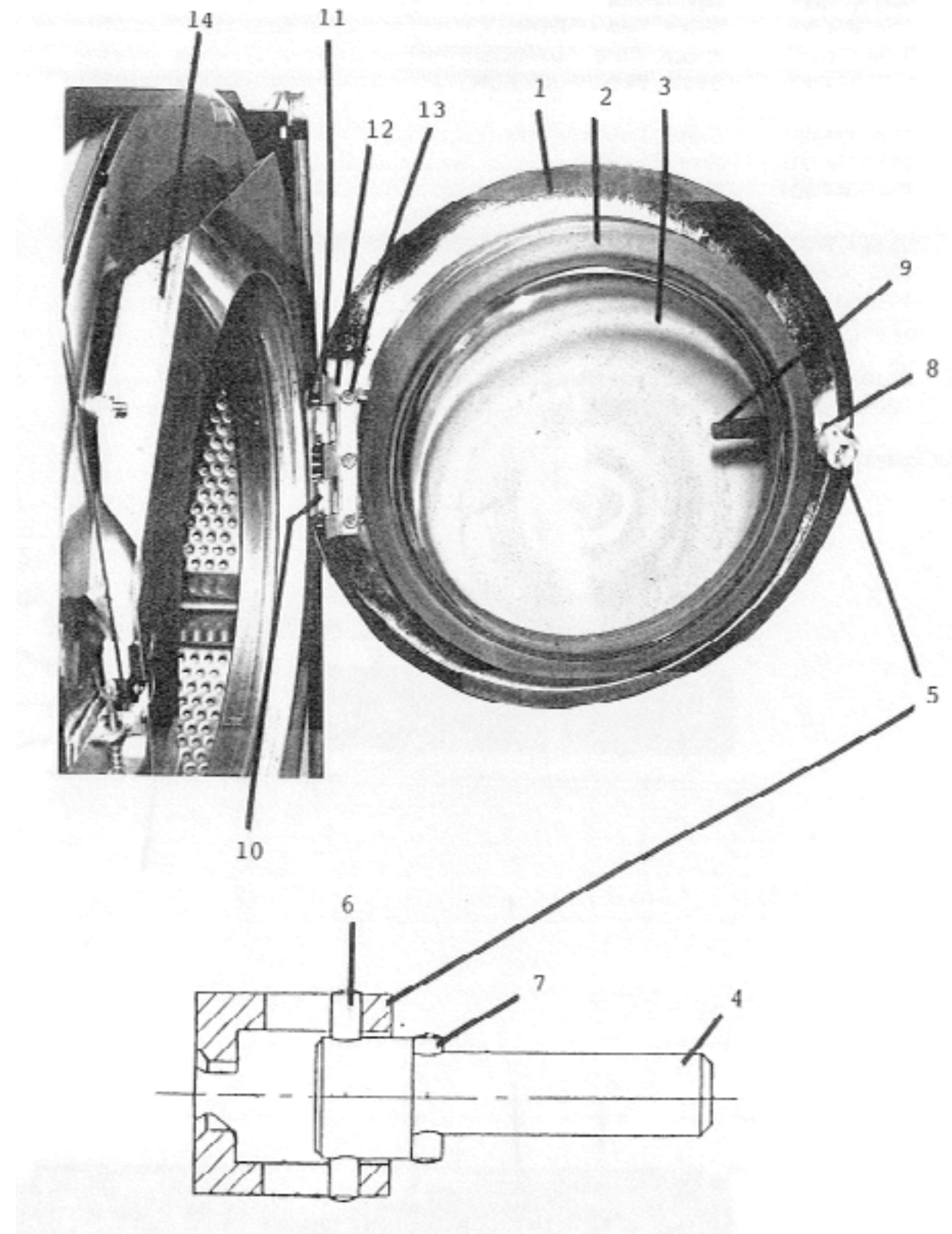

Chassis and Drain Part # by Model

Key	Part Number	Description	Qty
1	9945-101-002	Base Assy, Frame	1
2	9930-138-001	TubAssy	1
3	9950-053-002	Ring Assy, Tub Mtg-Front	1
4	9545-017-013	Screw, 1/2" grade 5	1
4	8640-417-002	Nut	1
4	8641-582-016	Lockwasher	1
5	9545-017-003	Bolt, 1/2 Grd 5. Tub to Base	2
5	8641-582-016	Lockwasher	4
5	8640-417-002	Nut, Hex	8
5	8641-581-026	Washer, Flat	
5	9552-013-001	Shim, Thin	AR
5	9552-013-002	Shim, Thick	AR
6	9379-187-001	Valve, Drain	1
7	9029-070-001	Bracket, Drain Valve	1
*	9545-048-001	Screw, Valve to Bracket	1
*	8641-581-018	Washer	1
8	9545-030-002	Screw, Bracket to Base	2
9	9915-120-002	Tube Assy, Drain	1
10	9545 030-002	Screw, Tube Mtg	4
11	9242-459-001	Hose, Tub to Drain Valve	1
12	9242-457-001	Hose, Drain Valve to Tube	1
13	8654-117-014	Clamp, Hose	4
14	9242-461-001	Hose, Injector Assy	1
*	9610-001-001	Vacuum Breaker	1
*	9029-069-001	Bracket, Vacuum Breaker	1
*	9545-008-005	Screw	4
15	8654-117-001	Clamp	2
*	9732-108-002	Dispenser	1
*	9206-416-001	Gasket, Dispenser	1
16	9242-450-001	Hose, Dispenser to Tub	1
17	8654-117-008	Clamp, Dispenser Hose	2
18	9974-007-001	Front Ass'y, Tub	1
19	9950 055-001	Ring Ass'y, Clamp (tub front to outer tub)	1
20	9545-029-009	Screw, 3/8	1
20	8640-415-001	Nut, Hex 3/8	1
*	9206-421-002	Gasket, Tub Front	1
21	8615-104-039	Pipe Plug	2
22	9242-449-003	Hose, Overflow	1
23	8654-029-000	Clamp, Hose	2

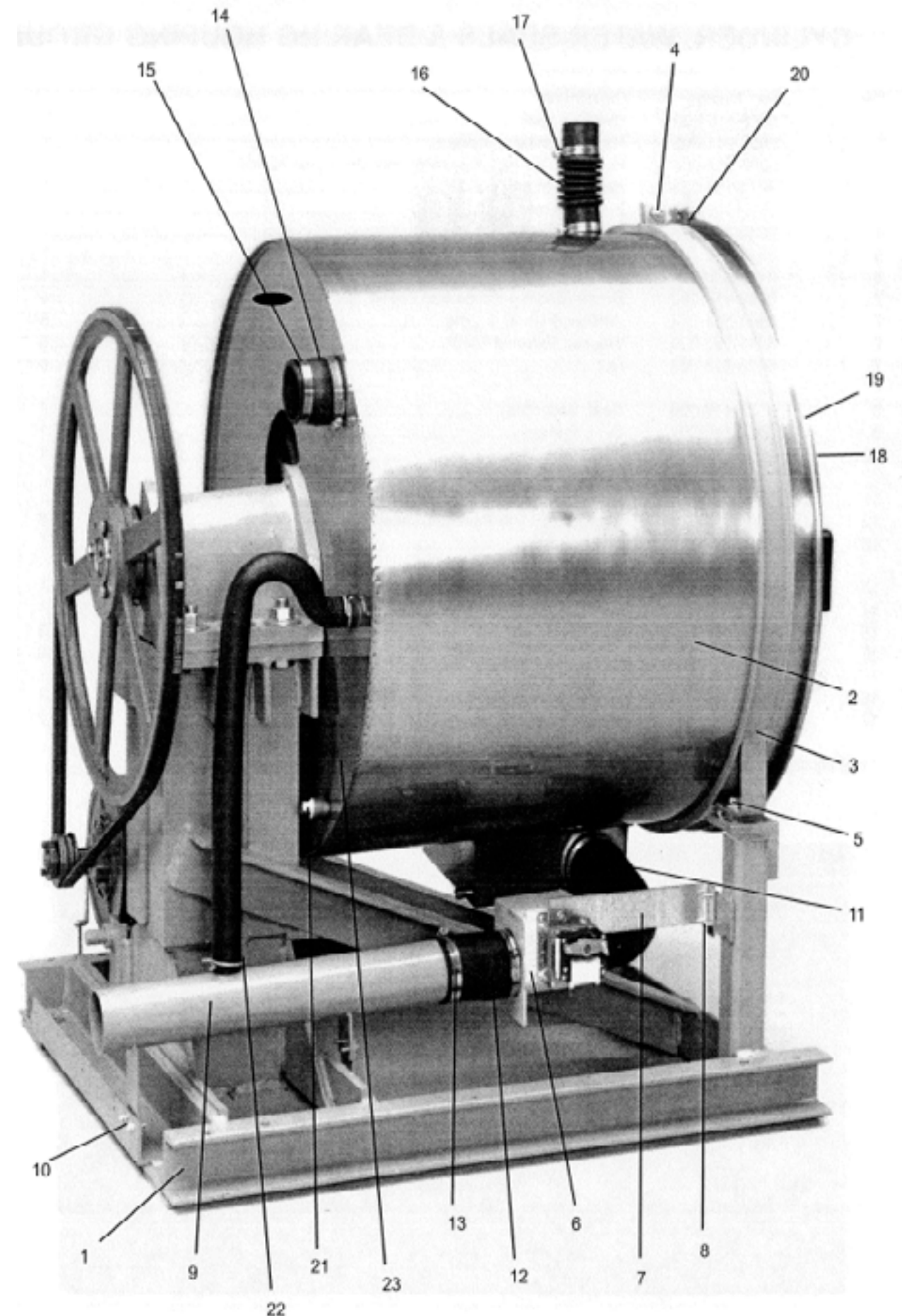

Water Inlet Valve Breakdown Part # by Model

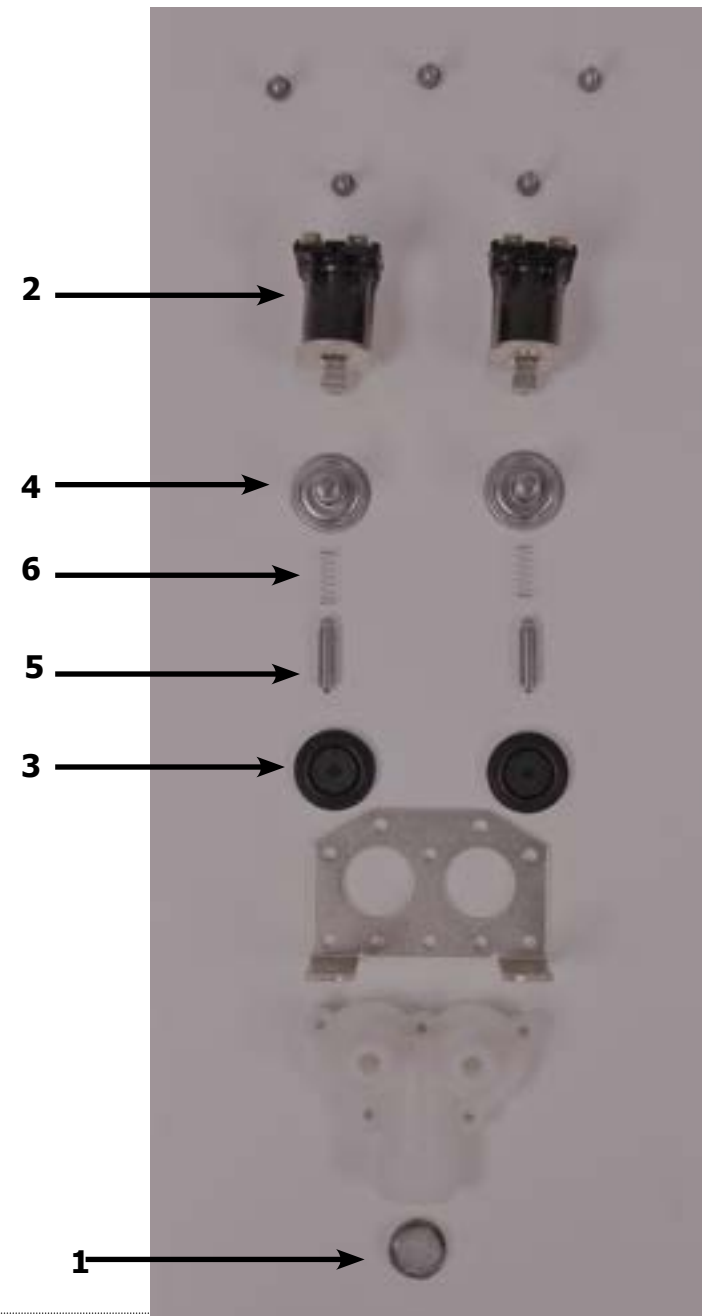

Key	Description	Part Number	QTY
*	Valve, Water Inlet (includes 1 thru 6)	9379-183-012	2
1	Screen, Inlet end of valve	9555-056-001	2
2	Coil Assy., 120 V Invensys	9089-017-001	2
3	Diaphragm Invensys (Viton)	9118-049-002	2
3	Diaphragm Invensys (EPDM)	9118-049-001	2
3	Diaphragm Invensys (EPDM NSF)	9118-049-003	2
4	Guide, Solenoid Invensys	9211-021-002	2
5	Armature Invensys	9015-008-001	2
6	Spring, Armature Invensys	9534-298-001	2

Water Inlet & Rear Channel

Key	Part Number	Description	Qty
1	9379-183-012	Valve, Water Inlet (see Water Inlet Valve Breakdown for individual parts)	2
2	9545-008-026	Screw, Valve Mtg	4
*	8640-399-009	Nut, Spring	4
3	9208-049-001	Guard, Water Valve	1
4	9545-008-026	Screw	2
5	9610-001-001	Vacuum Breaker	1
*	9029-069-001	Bracket, Vacuum Breaker	1
6	9545-008-026	Screw	4
			1
7	9242-453-018	Hose, Vac. Brkr. to Wash Dis	1
8	9242-453-019	Hose, Vac. Brkr. to Rinse Dis	1
9	9242-453-015	Hose, Hot Valve to Vac. Brkr	1
10	9242-453-007	Hose, Cold Valve to Vac. Brkr	1
11	9242-453-015	Hose, Hot Valve to Tub	1
12	9242-453-007	Hose, Cold to Tub	1
13	8654-117-015	Clamp, Hose-Worm	12
14	5198-211-004	Circuit Breaker	1
15	9883-005-001	Injector Assy, Soap	1
16	9241-461-001	Hose, Injector Assy	2
17	8654-117-001	Clamp	4

* Not Illustrated

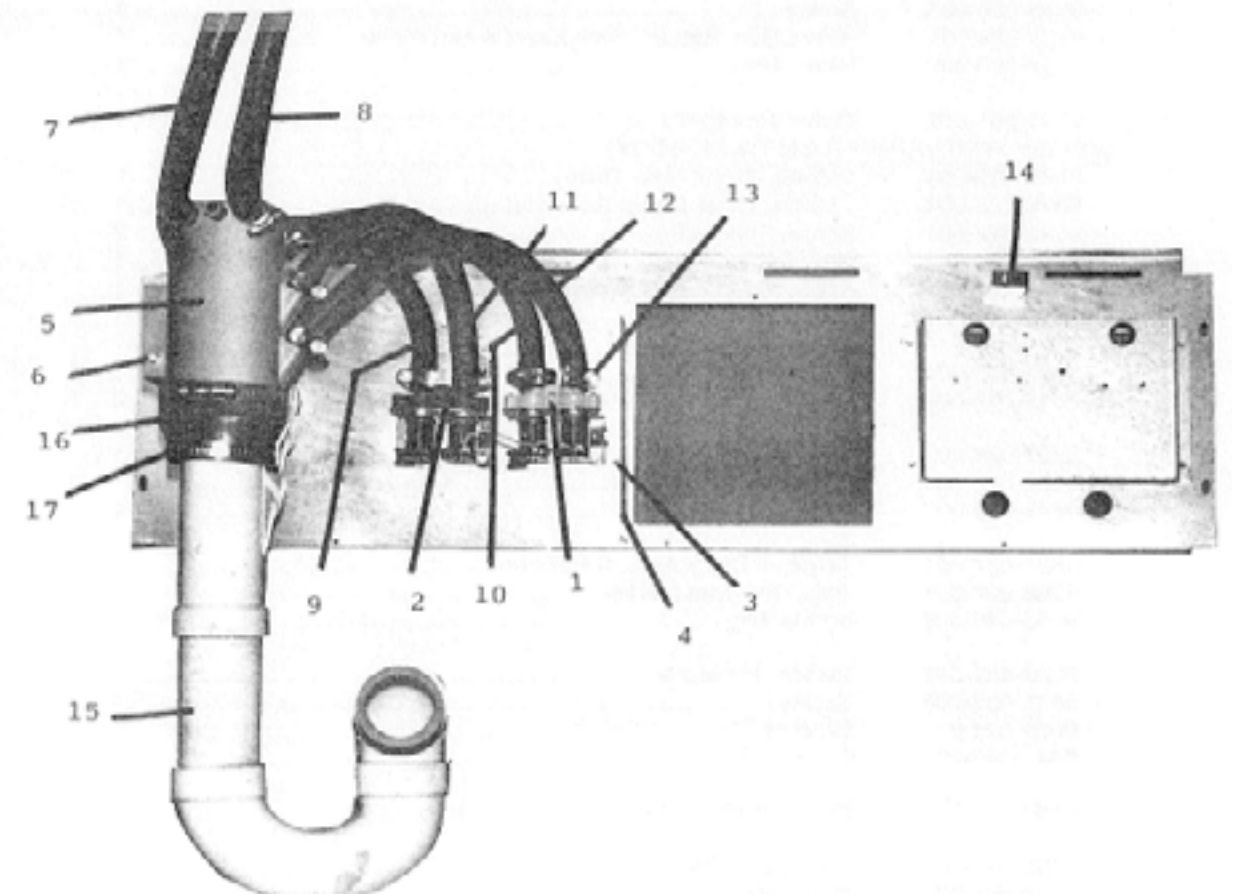

Electrical Components - Top Compartment

Key	Part Number	Description	Qty
1	9081-110-001	Channel, Trough Mtg	1
2	9545-008-023	Screws	2
3	9081-108-001	Channel, Dispenser Support	1
4	9545-008-026	Screw	2
5	9545-008-001	Screw, To Cntrl Panel	2
6	9839-013 001	Trough Assy, Controls Mtg	1
*	9545-008-005	Screw	4
7	5192-285-001	Relay, Run & Extract	2
8	5192-286-009	Relay, Spin	1
9	9571-361-002	Timer, Program	1
		(VERIFY PART NUMBER ON TIMER BODY)	
*	9376-295-004	Motor, Timer Main Drive	1
*	9376-286-004	Motor, Timer Rapid Advance	1
*	9545-012-001	Screw, Timer Mtg	2
10	9107-067-001	Dial, Timer	1
11	9307-176-001	Knob, Timer (w/set screws)	1
*	9538-157-006	Spacer, Knob	1
12	9571-360-001	Timer, Reversing	1
*	9545-044-004	Screw, Reversing Timer	2
13	9897-028-001	Terminal Block, 3 Position	1
14	9558-022-001	Strip, Terminal Marker	1
-- *	9545-045-007	Screw, Mtg	2
15	9897-029-001	Terminal Block Assy, 12 Position	1
*	9558-021-001	Strip, Terminal Marker	1
*	9545-045-007	Screw, Mtg	2
16	9539-482-001	Switch, Pressure	1
*	9545-031-003	Screw	1
*	9029-071-001	Bracket, Pressure Switch	1
*	9545-045-001	Screw, Mtg	2
17	5198-211-004	Circuit Breaker, 1.5 amp	1
18	8652-134-001	lug, Grounding	1
*	8639-621-007	Screw, Mtg	1
*	8641-582-006	lockwasher	1
19	8711-004-001	Transformer, Control	1
*	9545-008-026	Screw	1
*	8641-582-006	lockwasher	1
20	9375-001-002	Drive, VF-120G	1
21	9483-004-001	Resistor, Braking	2
*	9545-012-003	Screw	4
*	8640-413-002	Nut	4
22	9003-238-001	Angle, Drive Mtg LH	1
23	9003-238-002	Angle, Drive Mtg RH	1
*	9545-413-002	Nut	6

* Not Illustrated

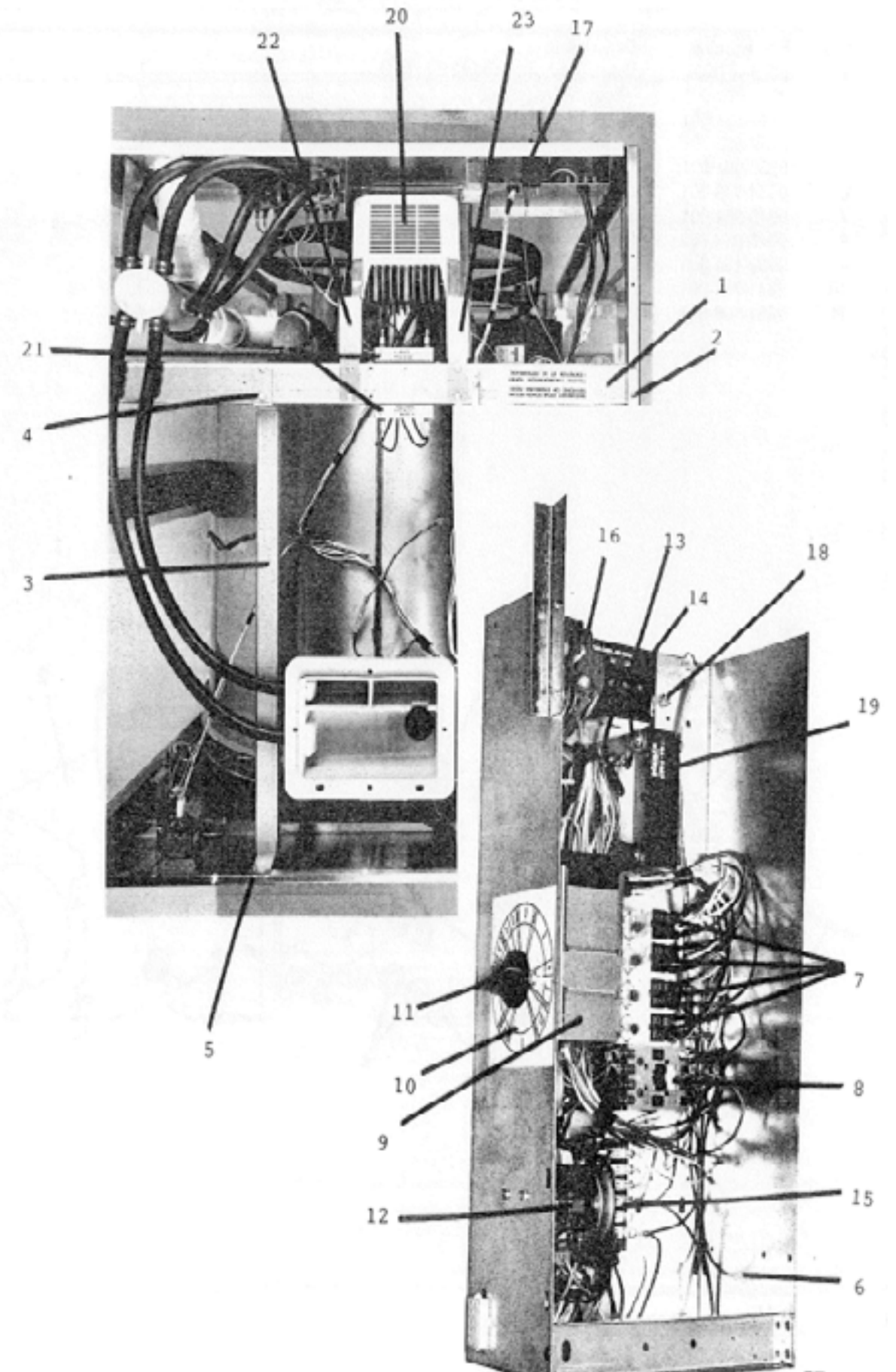

Control Panel Part # by Model

Key	Part Number	Description	Qty
1	9539-474-004	Switch, Red--OFF/ON	1
2	9539-474-005	Switch, White--ADVANCE/START	1
3	9539-474-006	Switch, Blue--PAUSE/RUN	1
4	9539-471-001	Switch, Rotary Selector	1
5	9307-176-001	Knob, Control	1
*	9545-044-004	Screw 6-32x1/4	2
6	9539-479-007	Switch, Push Button (Temp Selector)	1
7	8502-629-007	Label, Switch	1
*	8640-412-003	Nut, Switch Mtg	2
*	9538-165-001	Spacer	2
8	3310-041-001	Light, Cycle Control	1
*	9206-100-001	Gasket, Light	2

* Not Illustrated

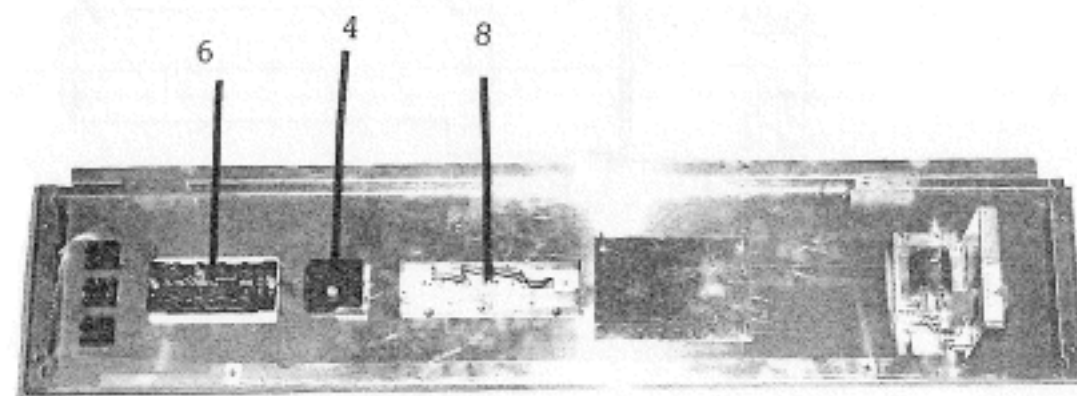
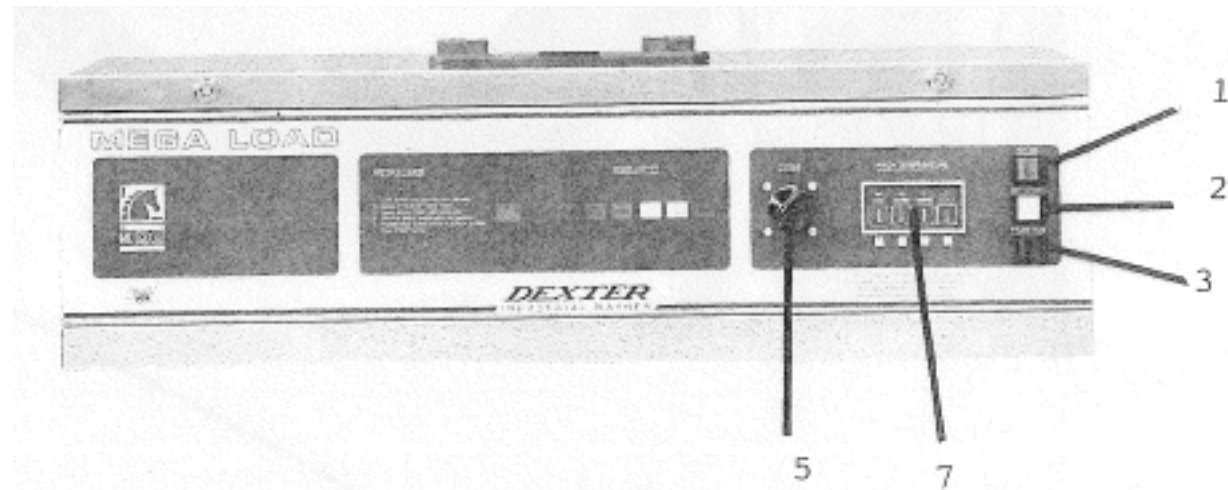

Terminal Blocks & Labels

Key	Part Number	Description	Qty
*	9897-034-001	Terminal Block, 6 Position	1
*	9558-027-001	Terminal Marker Strip	1
*	9545-045-007	Screw	2
*	9897-028-001	Terminal Block, 3 Position	1
*	9558-022-001	Terminal Marker Strip	1
*	9545-045-007	Screw	2
*	9897-033-001	Terminal Block, 4 Position	1
*	9558-025-001	Terminal Marker Strip	1
*	9545-031-010	Screw	2
*	9897-032-002	Terminal Block, 7 Position	1
*	9558-028-001	Terminal Marker Strip	1
*	9545-053-002	Screw	2
*	8652-134-001	Terminal Lug, Ground	1
*	8639-621-007	Screw	1
*	9544-041-002	Lockwasher	1
*	8652-130-037	Terminal, Grounding	1
*	8639-621-007	Screw	1
*	9544-041-002	Lockwasher	1
*	8502-624-002	Label, Warning Door Opening	1
*	8502-614-004	Label, High Voltage	1
*	8502-647-001	Label, Connections- Injector	1
*	8502-649-001	Label, Connections- Electrical	1
*	8502-619-004	Label, Fusing & Installation	1