

SWD A-Series Accessories

Key	Description	Part Number	Qty
*	Mounting Base 4"	9945-110-001	1
*	Mounting Base 6"	9945-111-001	1
*	Bevel Washer for 5/8" bolt used in installations using angle iron bases	8641-586-002	4
*	Bevel Washer for 3/4" bolt used in installations using angle iron bases	8641-586-003	4
*	Kit, Door Gasket Expander (large)	9732-139-002	1
*	Kit, Door Gasket Expander (small)	9732-139-001	1
*	Hose, Water Supply 3/8" I.D. x 48"	9990-027-011	2
*	Washer, Inlet Hose (furnished)	8641-242-000	1
*	Strainer, Inlet Hose (furnished)	9565-003-001	1
*	Sealing compound	8538-151-001	1
*	TORX#20	8545-051-002	1
*	Special Tool For Removing Coin Acceptor Mounting Screws. (T-10 Torx)	8545-051-003	1
*	Flow Restrictors (in dispenser)	9475-002-003	3
*	Battery 3V Lithium (used on Control PCB)	8612-001-001	1
*	VFD Filter options (3 phase)	9732-231-001	1
*	VFD Filter options (1 phase)	9732-232-001	1
*	Coin Bearing & Seal Kit	9732-219-004	1
*	Mode Light Support	9635-022-001	1
*	A to C Series Kit Blue	9732-312-003	*
*	A to C Series Kit Black	9732-312-004	*

Kits, Assemblies, & Common Parts

Description	Model
Coin Switch	9539-466-005
Coin Switch - Small terminals	9539-497-001
Kit - 8650-012-003 Lock with spacer	9732-344-001
Kit, Replacement for 9375-015-014	9732-345-033
Kit, 3" Drain Valve Replacement	9732-327-001
Drain Valve 3"	9379-202-001
Water Valve (Dual)	9379-183-012
Diaphragm	9118-049-003
Cylinder Plug (1.5" Plastic)	9456-041-007
Electronic Pressure Switch	9732-315-001
Breaking Resistor 200 Ohms	9483-004-002
Transformer, Main	8711-004-001
Transformer, Control	8711-010-001
Main Control Board	9473-009-008
Data Cable	9806-015-002
Door Lock Gear Motor Assembly	9985-011-009
Door Lock Latching Assembly	9885-024-001
Door Handle Only (Small)	9244-080-003
Door Switch	9539-492-001
Optical Coin Acceptor	9021-092-002
Coin Drop Screws	9545-053-002 x4
Retainer Coin Acceptor	9486-145-001
5/16 Hex Screw	9545-008-026
Belt	9040-077-003 x2
Top Lock Key #6324	9306-025-001
Fuse	8636-018-001
Fuseholder	9200-001-002
Door Glass Gasket	9206-419-001

Section 10:

Washer Parts

WSAD Wiring Harnesses Parts

Key	Description	Part Number	Qty
1	Add Bleech Light, (Wiring Harness included)	9794-001-001	1
2	Wiring Harness, Door Lock P15/P4	9627-816-002	1
3	Wiring Harness, CoinDrop Mech	9627-817-001	1
4	Wiring Harness, Drain,Thermo,DoorSol P17	9627-820-001	1
5	Data Cable	9806-015-002	1
6	Wiring Harness P20/P21	9627-818-001	1
7	Wiring Harness P8/P16	9627-819-001	1
8	Wiring Harness WaterValve/P19	9627-795-004	1
9	Wiring Harness LED PCB	9627-821-001	1
*	Wire Yellow Jumper (water valve)	8220-123-001	1
*	Harness Power Terminal Block	9627-747-002	1
10	Harness-Extention, Transformer	9627-826-001	1
12	Harness-P5/Pressure Switch	9627-822-001	1
*	Fuse-1,5a	8636-018-001	1
*	Fuseholder-Assembly	9200-001-002	1
*	Circuit Breaker (optional) 1.5 AMP	5198-211-004	1
*	Wiringlabel-schematic	9506-122-001	1
*	Wiringlabel-diagram	9506-123-001	1

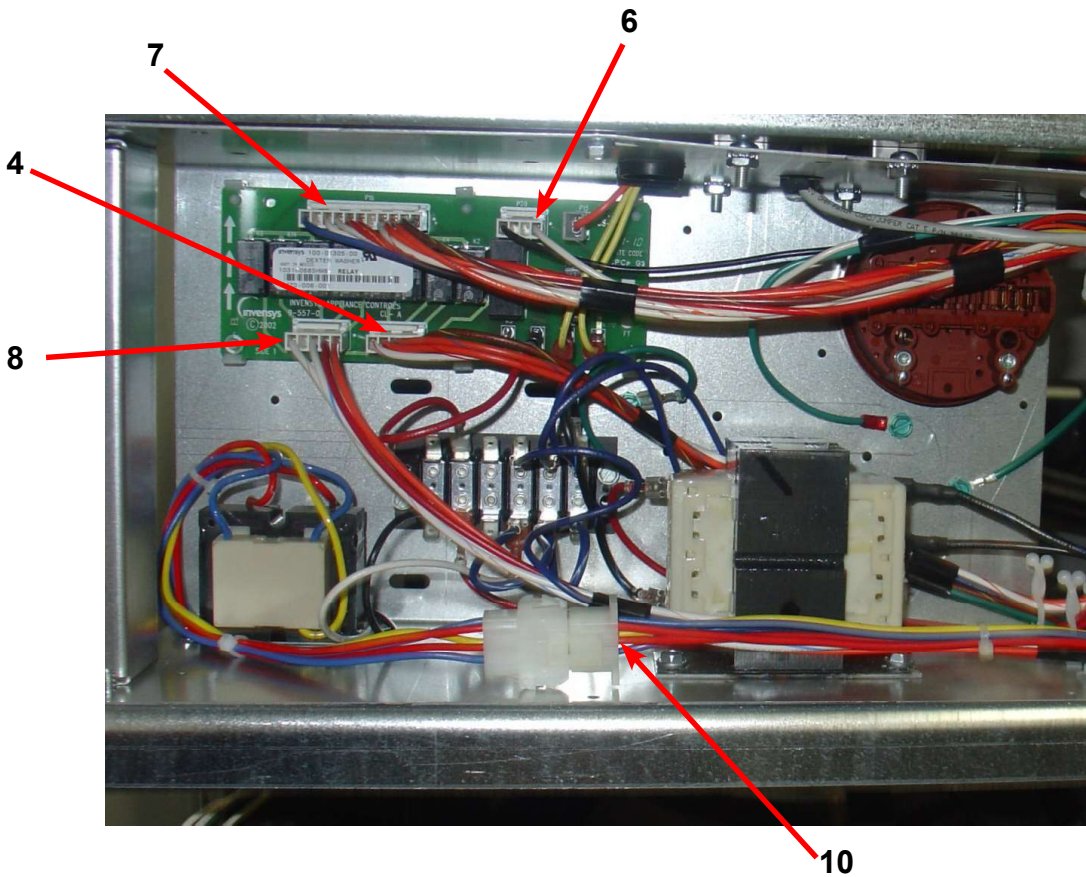
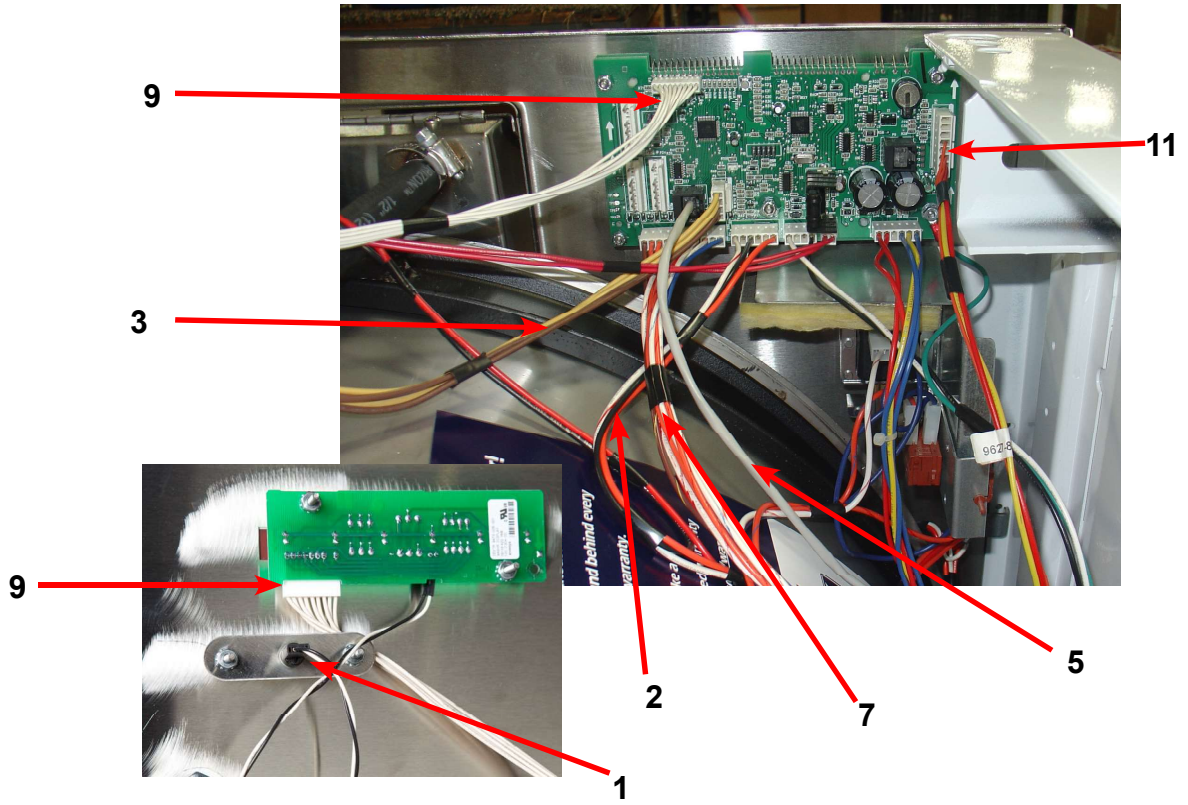

WSAD Rear View Access Parts Group Part

Key	Description	Part Number	Qty
1	Drive Motor, 3 Phase (Inverter duty)	9376-319-001	1
2	Rod, Motor Mtg	9497-222-006	1
*	Collar, Shaft (w/set screws) Before Serial # 530726	9076-052-002	2
*	Motor Bushing (plastic) Before Serial # 530726	9053-074-002	2
3	Motor Bushing (Rubber) after Serial #530726	9053-082-001	2
*	Clamp-Worm, 316SS, 1.5" (for Rubber bushing)	8654-117-019	2
4	Strap Bracket, Motor Tension (After Serial # 525645)	9029-206-002	1
*	Nut, Strap to Motor (After Serial # 525645)	8640-413-002	1
*	Strap Bracket, Motor Tension (Before Serial # 525645)	9029-027-005	1
*	Nut, Strap to Motor (Before Serial # 525645)	8640-414-003	1
*	Washer (Before Serial # 525645)	8641-581-006	1
5	Spring, Belt Tension	9534-319-002	1
*	Bolt, Eye (1/4"-20x1/2")	9545-055-002	1
*	Nut, 1/4 Elastic Stop	8640-414-003	1
*	Pulley, Motor	9453-170-003	1
*	Set Screw,Sq.Hd(motor pulley)	9545-028-015	2
*	Tolerance Ring	9487-234-003	1
6	Pulley, Driven	9453-168-003	1
*	Screw 5/8-11x1/2"	9545-060-001	1
*	Lockwasher 5/8"	8641-582-018	1
*	Washer, Flat 5/8x2 1/4"	8641-581-032	2
7	Drive Belt	9040-077-003	2
8	Channel, Rear	9081-131-001	1
*	Screw	9545-008-026	4
*	Nut, Spring	8640-399-007	4
*	Hose, Overflow to drain	9242-449-004	1
*	Clamp, Hose overflow to drain	8654-117-009	2
9	Hose, Overflow Vent Top	9242-463-005	1
*	Clamp, Hose Vent	8654-117-014	1
10	Vaccum Breaker ALL	9610-001-001	1
11	Bracket, Vacume Breaker	9029-121-001	1
12	Screw, 10B x 1/2	9545-008-026	4
13	Hose, Vacuum Breaker to tub	9242-458-001	1
*	Plastic Plug 7/8" Electrical Connection	9456-041-006	1
*	Panel Assy,, Back	9454-714-001	1
*	Screw Panel Mtg.#10Bx1/2"	9545-008-026	10
*	Screw Panel Mtg.#10Bx1/2"	9545-030-002	3
*	Nut, Spring	8640-399-004	8
14	Hose, Pressure Switch	9242-175-005	1
*	Clamp, Pressure Switch Hose	8654-117-015	1
15	VFD Delta "S" drive 208-240 volt	9375-015-014	1
16	Braking resistors (200 ohm)	9483-004-002	3
17	Bracket assembly (drive mounting)	9985-176-001	1

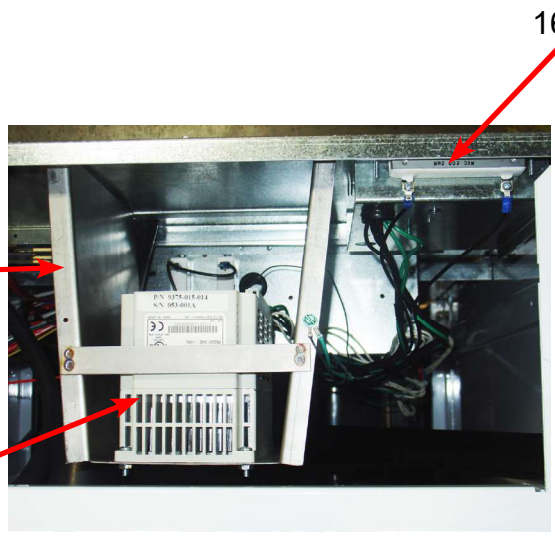
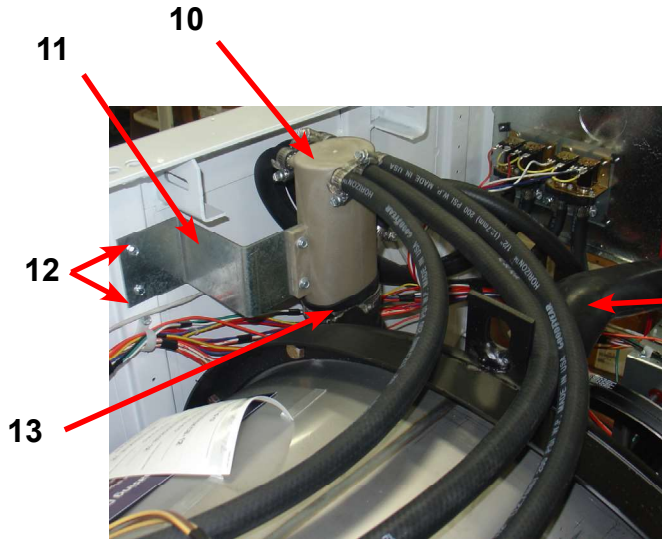
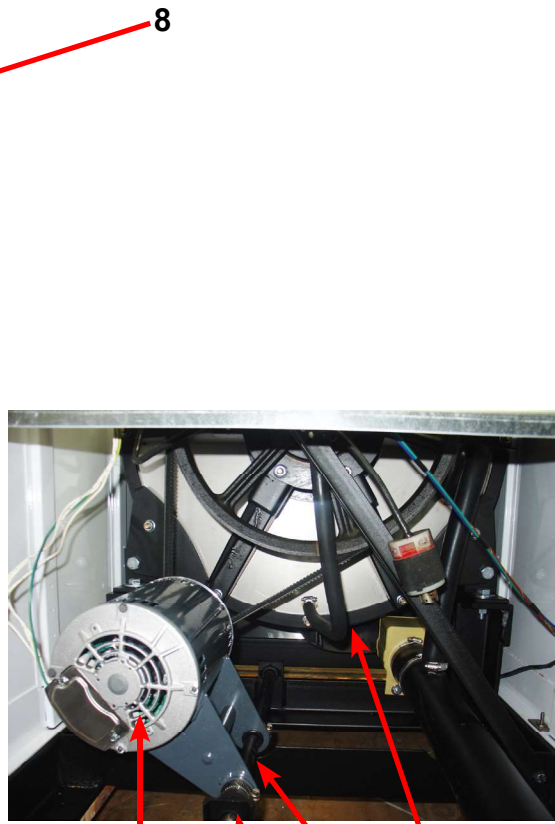
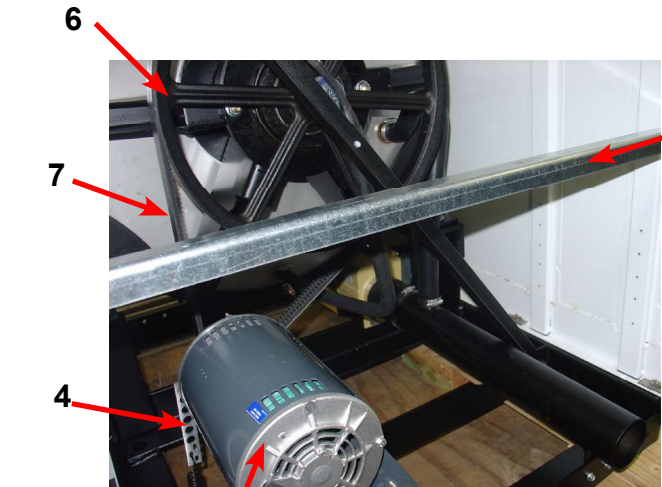

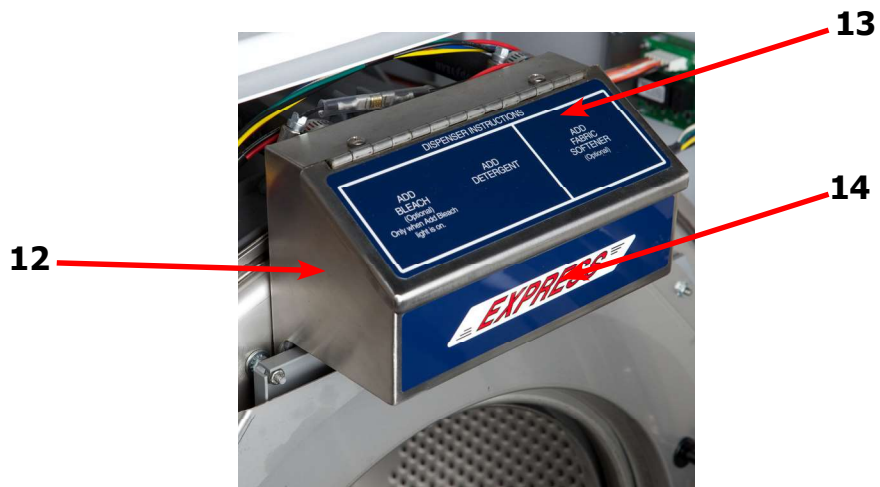
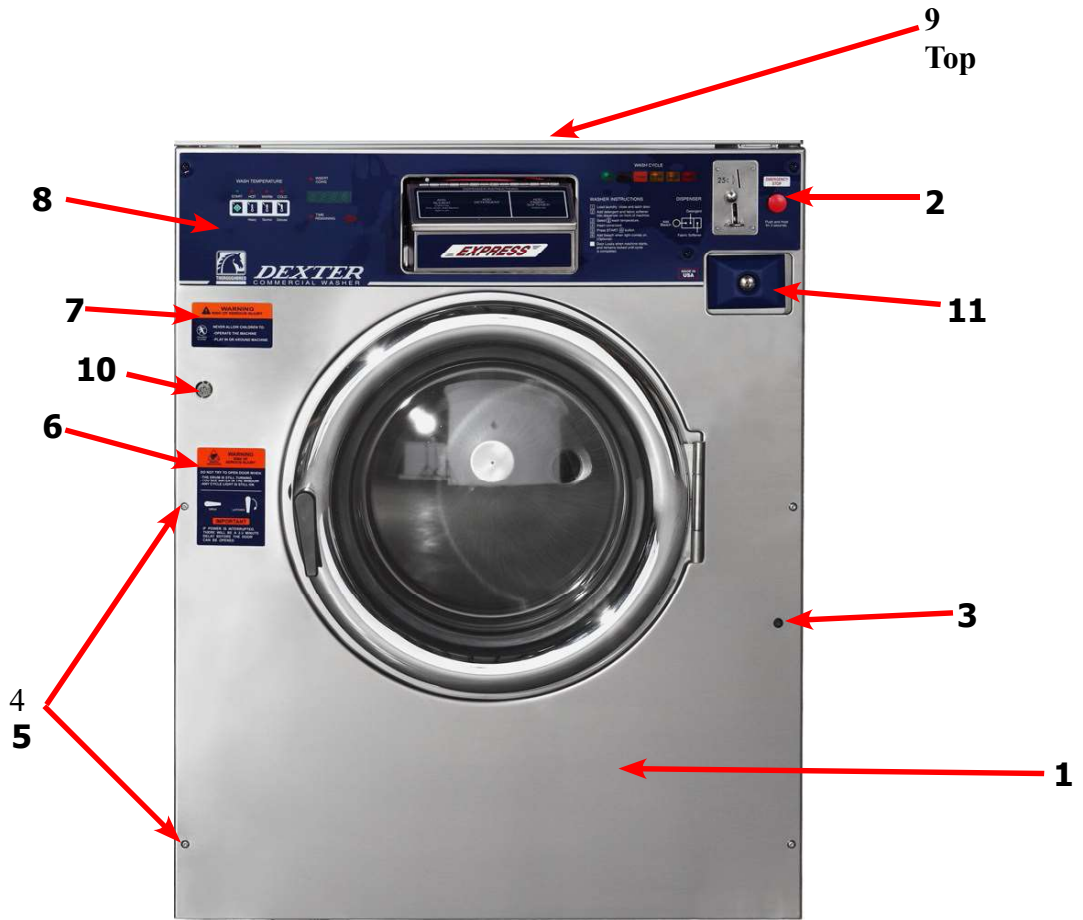

WSAD Cabinet and Front Panel Group Before Serial # 554488

Key	Description	Part Number	Qty
*	Panel, Right Side-Painted	9989-493-002	1
*	Panel, Left Side - Painted	9989-494-002	1
*	Bracket, Side Panel under front panel	9982-318-001	8
*	Screw	9545-018-023	8
1	Panel Assy, Front	9989-505-001	1
2	Switch Assembly, Stop Button Mounting Kit	9732-223-002	1
*	Stop Button Mounting Plate	9452-725-001	1
3	Bumper Loading Door	9051-053-001	1
4	Screw, Flat Head- Front to Sides	9545-008-020	4
5	Washer, Finish	8641-582-019	4
*	Nut, Spring-To Front Panel	8640-442-001	4
6	Label, Door Opening	8502-723-001	1
7	Label, Risk of Injury	8502-722-002	1
8	Nameplate Decal, Control Panel	9412-143-001	1
9	Panel Top, Front, Painted	9989-470-002	1
*	Screw, Hex, #10B x 1/2	9545-008-026	8
*	Panel Top Rear	9454-717-001	1
*	Screw, Hex, #10B x 1/2	9545-008-026	6
10	Lock, Top (w/Key)	8650-012-003	2
*	Key, Top- # 6324	6292-006-007	1
*	Cam, Lock-Top	9095-042-001	2
*	Nut, 9/32 - 28 Hex	8640-426-001	2
*	Washer Flat 5/16	8641-581-008	2
*	SS Coin Vault Assy, Coin	9942-028-003	1
11	Coin Box, Blue	9807-099-001	1
12	Soap Dispenser Assembly, Complete (Does not include lid)	9807-087-001	1
*	Soap Box mounting Gasket	9206-422-001	1
13	Lid Assembly soap box	9987-104-001	1
*	Lid screws #10-32x1/2 SS	9545-012-017	2
*	Nut Hex Elasticstop #10-32 SS	8640-413-006	6
*	Bracket Soap box mounting	9029-122-002	1
*	Softner siphon tube (plastic)	9574-252-002	1
*	Flow restrictors	9475-002-003	3
14	Label "EXPRESS", Soap Dispenser	8502-715-001	1

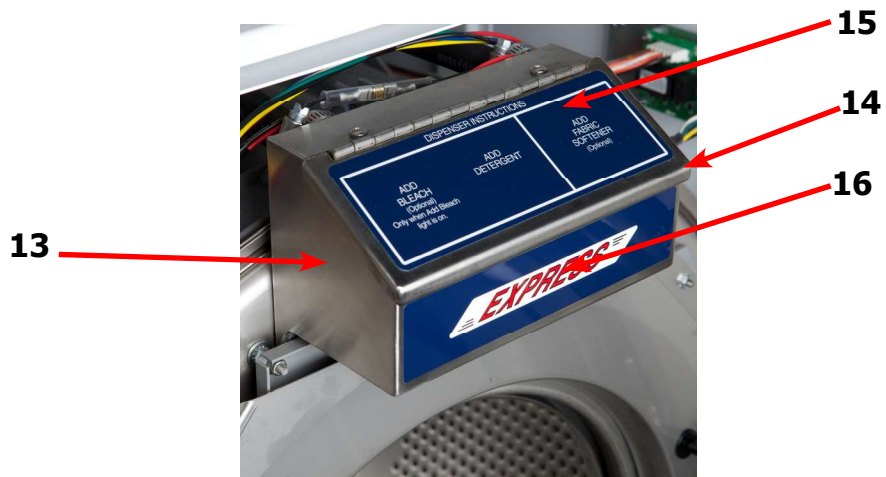

WSAD Cabinet and Front Panel Group After Serial #554488

Key	Description	Part Number	Qty
*	Panel, Right Side-Painted	9989-493-002	1
*	Panel, Left Side - Painted	9989-494-002	1
*	Bracket, Side Panel under front panel	9982-318-001	8
*	Screw	9545-018-023	8
1	Panel Assy, Front	9989-551-001	1
2	Switch Assembly, Stop Button Mounting Kit	9732-223-002	1
*	Stop Button Mounting Plate	9452-725-001	1
3	Bumper Loading Door	9051-053-001	1
4	Screw, Torx Head- 10AB x 3/4,	9545-008-020	4
*	Nut, Spring-To Front Panel	8640-399-001	4
5	Label, Door Opening, Blue	8502-723-001	1
5	Label, Door Opening, Black	8502-742-001	1
6	Label, Risk of Injury, Blue	8502-722-002	1
6	Label, Risk of Injury, Black	8502-741-001	1
7	Nameplate Decal, Control Panel, Blue	9412-143-001	1
7	Nameplate Decal, Control Panel, Black	9412-203-001	1
8	Button, Push Control, Blue	9035-062-001	1
8	Button, Push Control, Black	9035-062-002	1
9	Screw, Torx Head- 10AB x 3/4, Blue	9545-008-009	2
9	Screw, Torx Head- 10AB x 3/4, Black	9545-008-036	2
10	Panel Top, Front, Painted	9989-470-002	1
*	Screw, Hex, #10B x 1/2	9545-008-026	8
*	Panel Top Rear	9454-717-001	1
*	Screw, Hex, #10B x 1/2	9545-008-026	6
11	Lock, Top (w/Key)	8650-012-003	2
*	Key, Top- # 6324	6292-006-007	1
*	Cam, Lock-Top	9095-042-001	2
*	Nut, 9/32 - 28 Hex	8640-426-001	2
*	Washer Flat 5/16	8641-581-008	2
*	Coin Vault Assy, Coin	9942-028-003	1
12	Coin Box, Blue	9807-099-001	1
12	Coin Box, Black	9807-099-003	
13	Soap Dispenser Assembly, Complete (Does not include lid)	9807-087-001	1
*	Soap Box mounting Gasket	9206-422-001	1
14	Lid Assembly soap box	9987-104-001	1
*	Lid screws #10-32x1/2 SS	9545-012-017	2
*	Nut Hex Elasticstop #10-32 SS	8640-413-006	6
*	Bracket Soap box mounting	9029-122-002	1
*	Softner siphon tube (plastic)	9574-252-002	1
*	Flow restrictors	9475-002-003	3
15	Label, Dispenser Instructions, Blue	8502-678-001	1
15	Label, Dispenser Instructions, Black	8502-745-001	1
16	Label "EXPRESS", Soap Dispenser, Blue	8502-715-001	1
17	Door, Lower Service Assembly (w/handle)	9960-286-006	1
18	Handle, Lower Service Door	9244-086-005	1
19	Screw, Torx Head- 10AB x 3/4,	9545-008-020	4

WSAD Cylinder, Seals & Bearings Parts

Description		Part Number	Qty
*	Bearing and Seal Kit	9732-219-005	1
*	Housing, Bearing- Assembly (items #2-#6)	9803-186-001	1
2	Housing, Bearing	9241-180-002	1
3	Bearing, Front (LARGE)	9036-159-005	1
4	Bearing, Rear (SMALL)	9036-159-004	1
5	Spacer, Bearing	9538-167-001	1
6	Ring, Bearing Retainer	9487-238-003	1
8	Seal, Small	9532-140-002	1
9	Seal, Large	9532-140-006	1
10	Ring, Seal Mounting	9950-048-001	1
11	Tub Back Mating Ring	9487-261-003	1
12	Bolt 5/8-11x1 1/2" Tub end of bearing Housing	9545-060-001	6
12	Nut 5/8"-11	8640-425-001	6
13	Support Arm Assy, Bearing Housing	9991-056-002	6
14	Bolt Pulley end of bearing housing, 7/16-14x2"	9545-059-003	6
*	Nut, Flange Locking 7/16"	8640-416-005	6
15	Pulley, Driven	9453-168-003	1
16	Ring, Tolerance	9487-234-003	1
17	Washer 5/8"x 2 1/4"	8641-581-032	2
18	Bolt 5/8-11x1 1/2"	9545-060-001	1
19	Lockwasher 5/8 Ext. tooth	8641-582-018	1
*	Cylinder Assy	9732-354-005	1
*	Tub and Cylinder Assy.	9869-011-002	1
*	Plastic Plug 1 1/2"-(inside cylinder)	9456-041-007	1

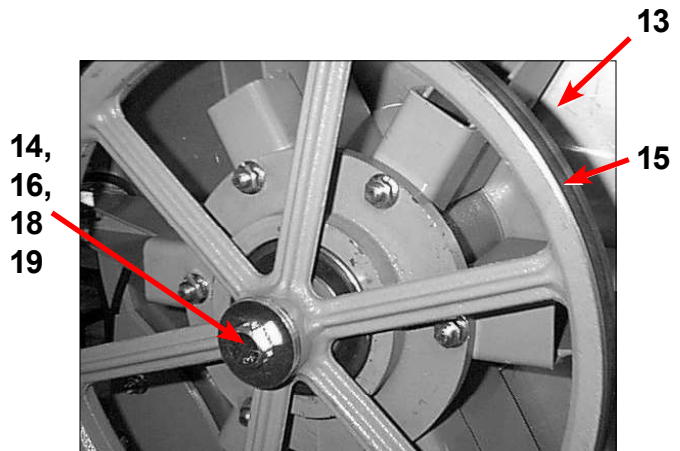
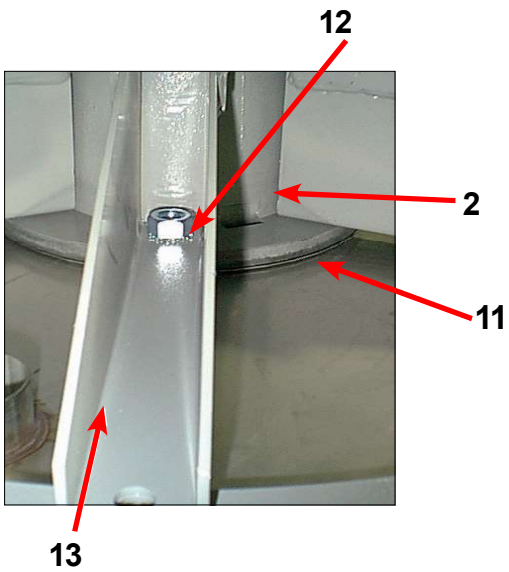
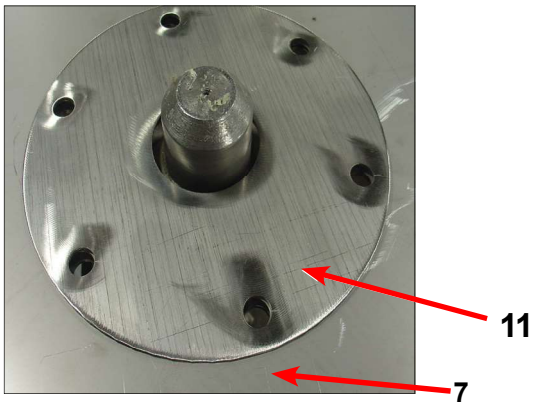
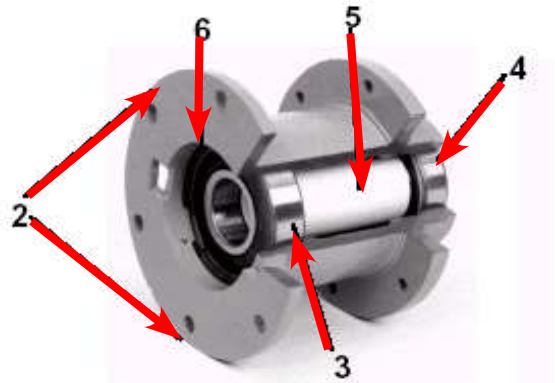
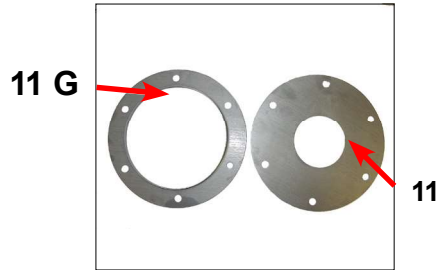
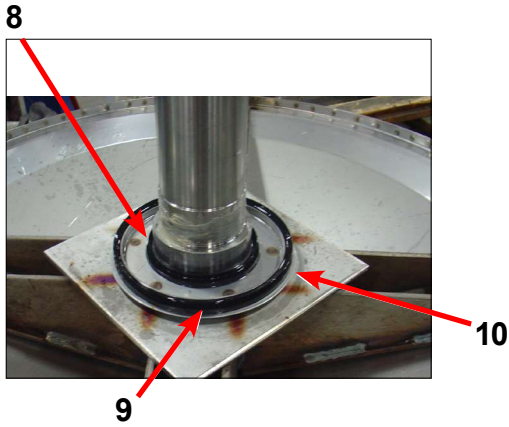
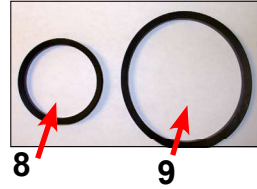
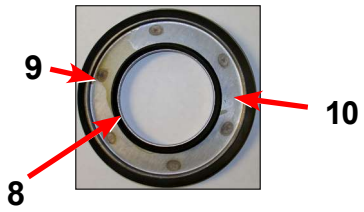

Door Lock Assembly (continued)

Key	Description	Part Number	Qty
33	Lock Assy, Complete (#1-22)(includes #1 thru #22)	9885-024-001	1
1	Plate Assy, Door Lock	9982-346-001	1
2	Washer, Flat	8641-581-030	1
3	Actuator, Latching Switch	9008-005-001	1
4	Pawl, Locking	9732-346-002	1
5	Washer, Spring	8641-569-003	1
6	Ring, Retaining	9487-200-004	1
7	Bracket Switch	9029-163-001	1
8	Nut, Hex 10-32 UNF	8640-413-002	2
9	Spring, Actuating	9534-364-002	1
10	Screw, Hx. 10-32 x 1"	9545-012-020	1
11	Nut, Elastic Stop 10-32	8640-413-004	2
12	Spring, Return	9534-364-001	2
13	Pin, Guide	9451-193-001	1
14	Ring, Retaining	9487-200-005	1
15	Washer	8641-581-031	1
16	Switch, Latching Sensing	9539-461-008	1
17	Shield, Switch	9550-169-003	3
18	Screw 4-40 x 5/8"	9545-020-001	2
18	Nut, Twin 4-40	8640-401-001	1
19	Switch, Locking Sensing	9539-461-007	2
20	Actuator, Switch Locking	9008-006-003	1
21	Screw 4-40 x 1 1/8"	9545-020-003	2
21	Nut, Twin 4-40	8640-401-001	1
*	Spacer Sensor	9538-182-001	*
*	Shim, Door Lock, Thin	9552-037-001	AR
*	Screw, Lock mtg 1/4"-20 x 3/4"	9545-018-014	3
*	Lockwasher 1/4" Ext tooth	8641-582-007	3

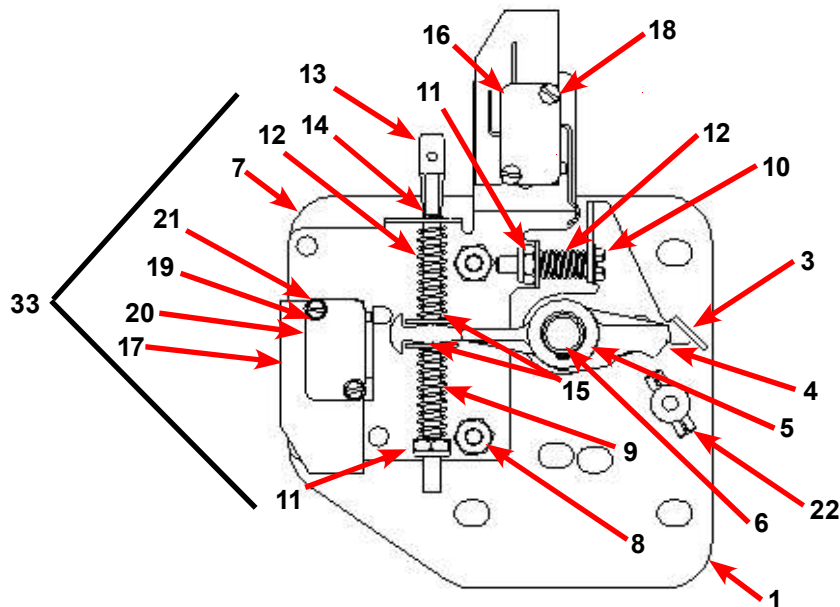

WSAD Door Lock Solenoid Assembly

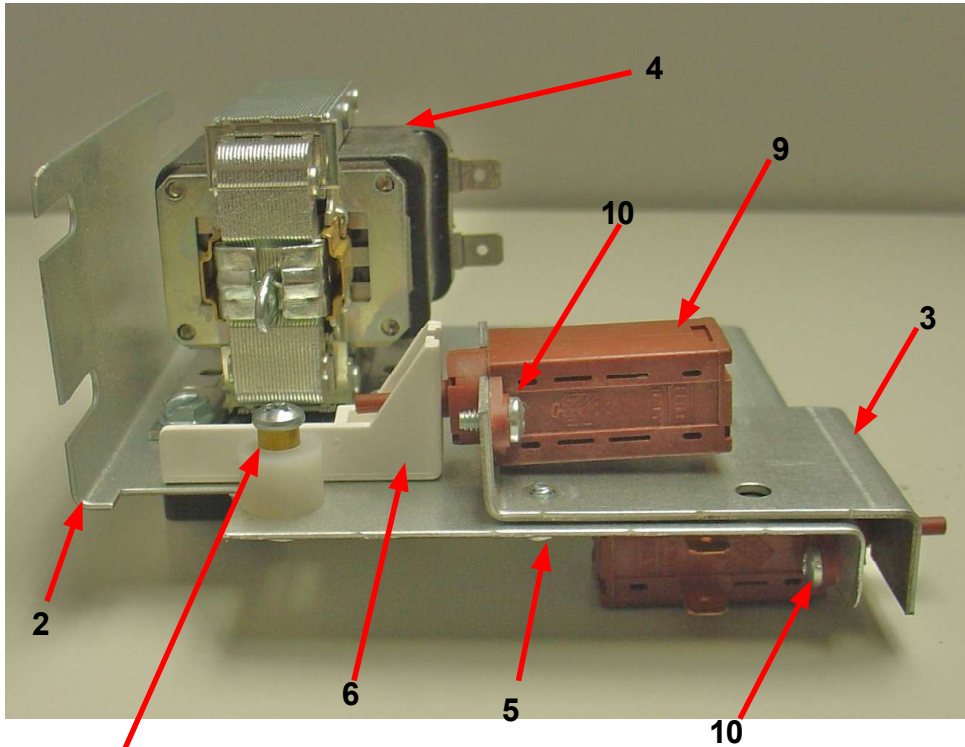

11, 12, 13

Key	Description	Part Number	Qty
1	Solenoid Ass'y, Door Locking (includes 23 thru 32)	9985-011-009	1
2	Bracket, (Door Locking Solenoid)	9985-169-001	1
4	Solenoid 120V 60 hz	9536-082-002	1
5	Screw, Solenoid Mtg	9545-008-001	3
6	Stop, Door Lock Solenoid	9540-036-001	1
7	Screw, Shoulder	9545-061-001	1
*	Nut, Keps #6	8640-411-002	1
9	Thermoactuator 120 V	9586-001-001	2
10	Screw #6 x 5/16"	9545-031-011	4
11	Spacer, Plastic	9538-157-004	1
12	Spacer, Metal	9538-166-004	1
13	Screw, Cross Recessed	9545-010-001	1
14	Nut, Keps #8	8640-412-005	1
*	Rod, Pull	9497-225-008	1
*	Nut, Sol. Brkt. to Control Panel	8640-412-005	3
*	Gear Motor Locking Kit	9732-283-003	*

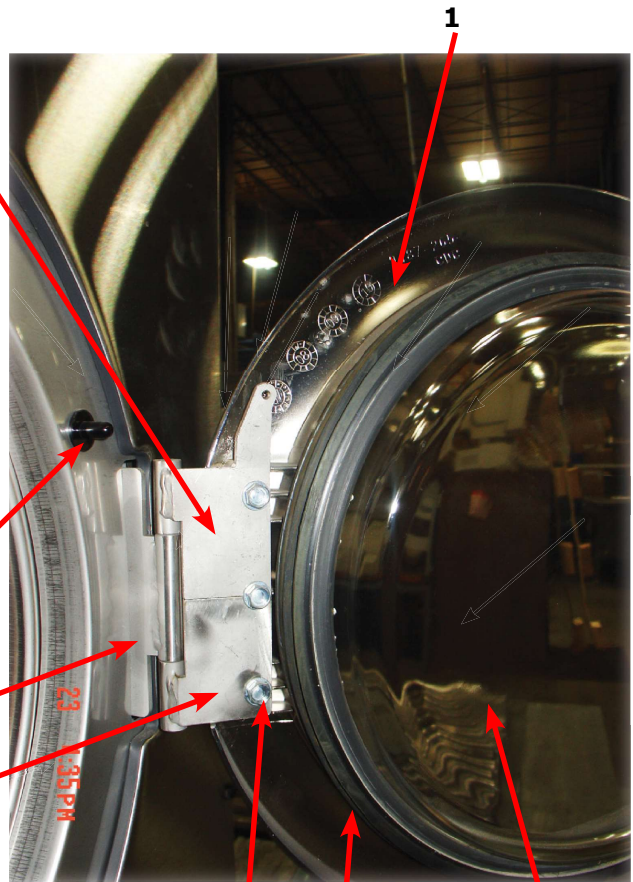
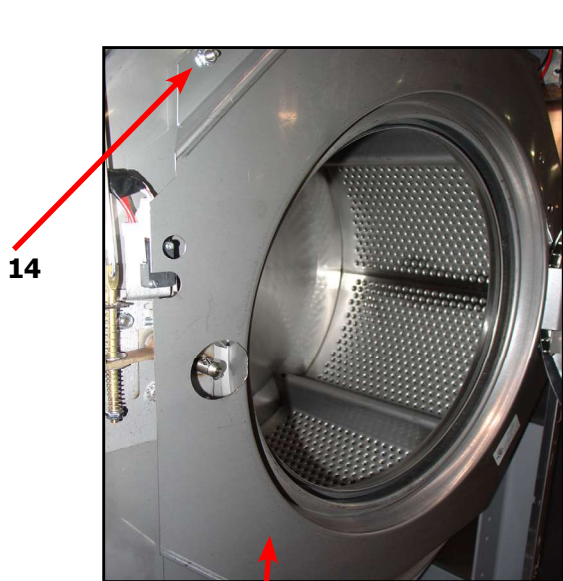

16
Plunger
Switch

15

12

14

13

11

2

3

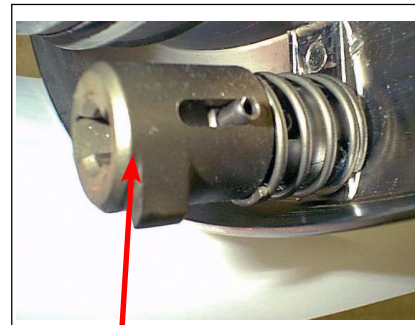
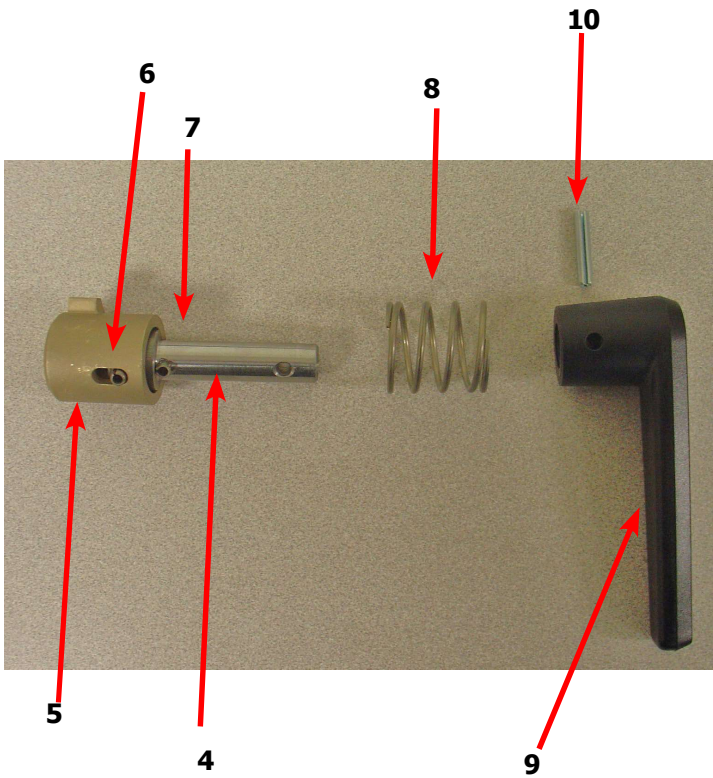

WSAD Loading Door Group Parts

Key	Description	Part Number	Qty
	Loading Door, Complete #1-10	9960-274-004	1
1	Loading Door, Ring (180 Degreese)	9487-265-002	1
2	Gasket, Loading Door	9206-419-001	1
3	Window, Loading Door	9635-016-001	1
*	Shaft Assy, Locking (includes 4 thru 7)	9913-134-003	1
4	Shaft, Door Locking	9537-195-002	1
5	Cam, Locking	9095-040-002	1
6	Pin, Groove (1 1/4)	9451-181-005	1
7	Pin, Groove (3/4)	9451-181-004	1
8	Spring, Lock Cam	9534-360-002	1
9	Handle, Door	9244-080-003	1
10	Pin, Door Handle (groove)	9451-181-006	1
11	Screw, Loading Door Mtg (5/16" TF)	9545-056-002	3
*	Shim, Loading Door Hinge, Thin	9552-037-001	1
12	Door Hinge Assembly Mounts to Tub Front	9550-030-001	1
*	Screw, Hinge Mtg 5/16" -18x 3/4"	9545-014-009	3
*	Lockwasher 5/16" Ext tooth	8641-582-009	3
*	Wiring Harness doorlock safety Switch Assembly	9627-816-002	1
*	Wire Assembly Door Close Switch, Red 17"	8220-063-025	1
*	Wire Assembly Door Close Switch, BLK 17"	8220-063-026	1
13	Leaf assembly, Hinge Top (Push Button Style)	9545-005-004	1
14	Leaf assembly, Hinge Bottom	9545-005-002	1
15	Masking Ring (push Button SwitchStyle)	9487-273-002	1
16	Switch, Door closed Switch (Push Button style)	9539-492-001	1
*	Masking Ring (Micro Switch Style)	9950-060-002	1
*	Leaf assembly, Hinge Top (Micro Switch Style)	9845-005-003	1
*	Switch Assembly, Door Closed (Micro Switch Style)	9801-089-001	1
*	Box, Door Switch	9041-087-001	1
*	Bushing-Insulating, Plastic	9053-067-003	1
*	Switch, Micro	9539-461-007	1
*	Shield-Door Switch	9550-159-001	1
*	Nut-Special Twin #4-40	8640-401-001	1
*	Screw, #4-40 x 5/8	9545-020-001	2
*	Wire Assembly, BLK 17"	8220-062-028	1
*	Wire Assembly, RED 17"	8220-062-027	1
*	Actuator, Door Switch	9008-004-001	1

WSAD Loading Door Hinge Parts Group

With Pin (Before Serial # 507538)

Key	Description	Part Number	Qty
*	Loading Door, Complete #1-10	9960-274-004	1
1	Loading Door, Ring	9487-265-002	1
2	Gasket, Loading Door	9206-419-001	1
*	Window, Loading Door	9635-016-001	1
*	Shaft Assy, Locking (includes 3 thru 6)	9913-134-003	1
3	Shaft, Door Locking	9537-195-002	1
4	Cam, Locking	9095-040-002	1
5	Roll Pin Type, Groove (1 1/4)	9451-181-005	1
6	Roll Pin Type, Groove (3/4)	9451-181-004	1
7	Spring, Lock Cam	9534-360-002	1
8	Handle, Door	9244-080-003	11
9	Roll Pin Type, Door Handle (groove)	9451-181-006	
12	Door Hinge (mounts to tub)	9950-030-001	1
*	Screw, 5/16-18 x 3/4	9545-014-009	3
*	LockWasher-External tooth, 5/16	8641-582-009	3
13	Top Door Hinge Leaf with switch pin	9845-005-003	1
14	Bottom Door Hinge Leaf	9845-005-002	1
10	Masking Ring Assembly (For Micro Switch Box Door Switch)	9950-060-002	1
16	Switch Box Assembly, Door Closure (#17 thru #20)	9801-089-001	1
17	Box-Door Switch	9041-087-001	1
18	Bushing-Insulating, Plastic	9053-067-003	1
15	Switch-Micro	9539-461-007	1
*	Shield-Doorswitch	9550-159-001	1
19	Nut-Special Twin, #4/40	8640-401-001	1
*	Screw, 4/40 x 5/8	9545-020-001	2
*	Red Wire (Door Close Switch)	8220-062-027	1
*	Black Wire (Door Close Switch)	8220-062-028	1
20	Acuator-Doorswitch	9008-004-001	1

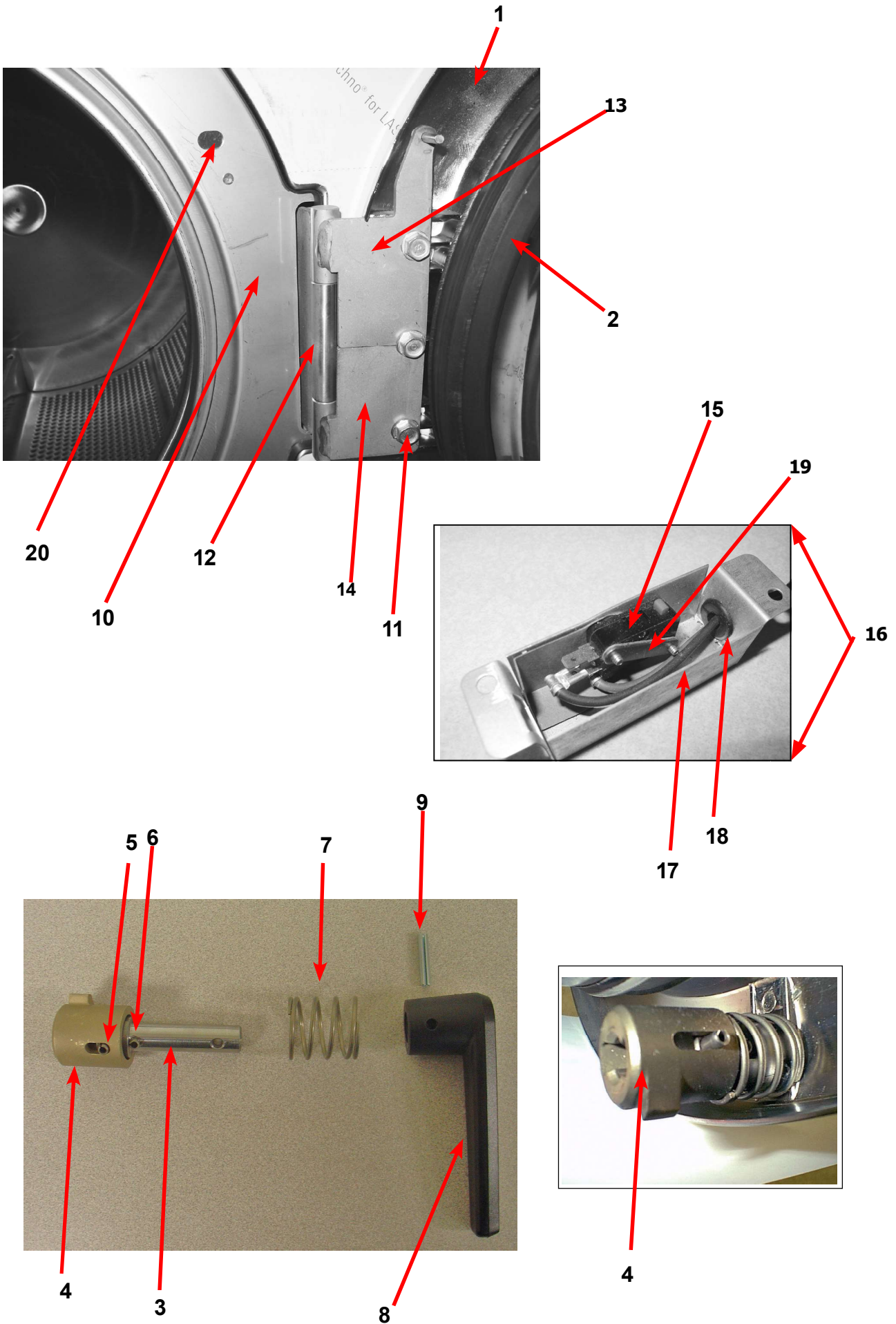

Drain Valve Group Part # by Model

Key	Description	Part Number	Qty
1	Valve, Drain (includes #2 thru #11)	9379-202-001	1
2	Body, Valve (w/ball)	9064-070-001	1
3	Motor & Gear Train (complete)	9914-137-011	1
4	Plate, Motor Mtg	9452-538-001	1
5	Screw	8639-994-001	1
6	Spring, Drive	9534-339-001	1
7	Screw	9545-054-001	1
8	Screw	9545-054-002	1
9	Seal, V Packer	9532-134-001	1
10	Washer	8641-584-001	1
11	Pin, Main Drive	9451-196-001	1
*	Plate (spacers needed for replacement motor mtg. plate)	9538-149-001	1
13	Stator and Coil Assembly	9089-036-004	1
*	Replacement Seal Kit	9732-327-001	*

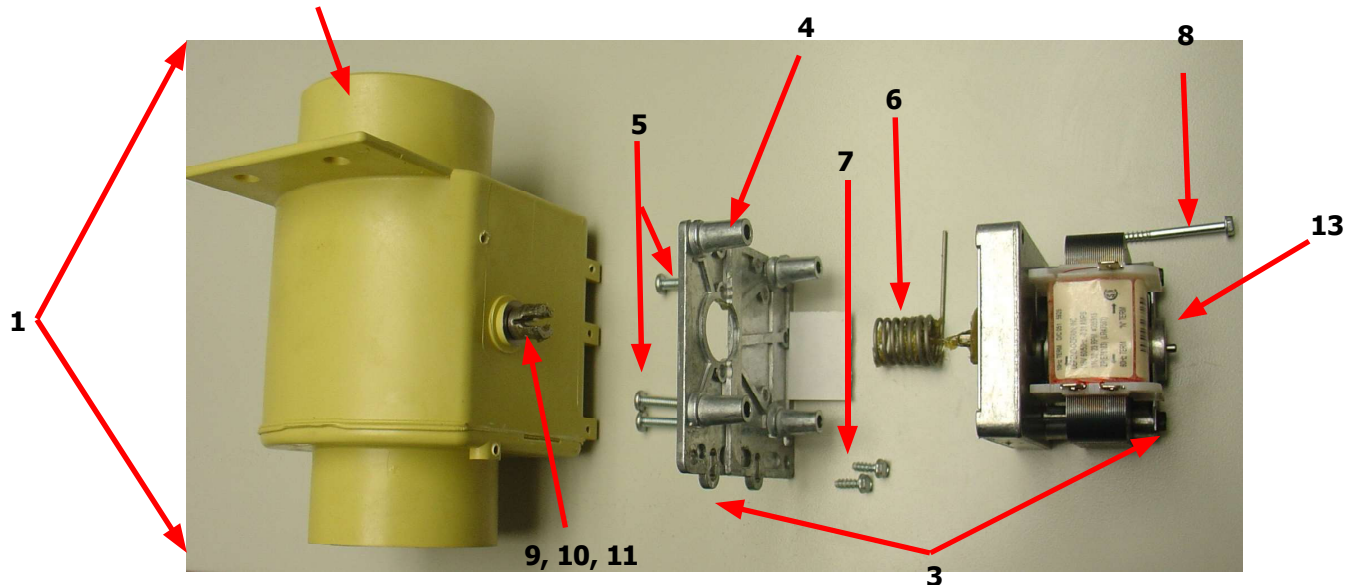
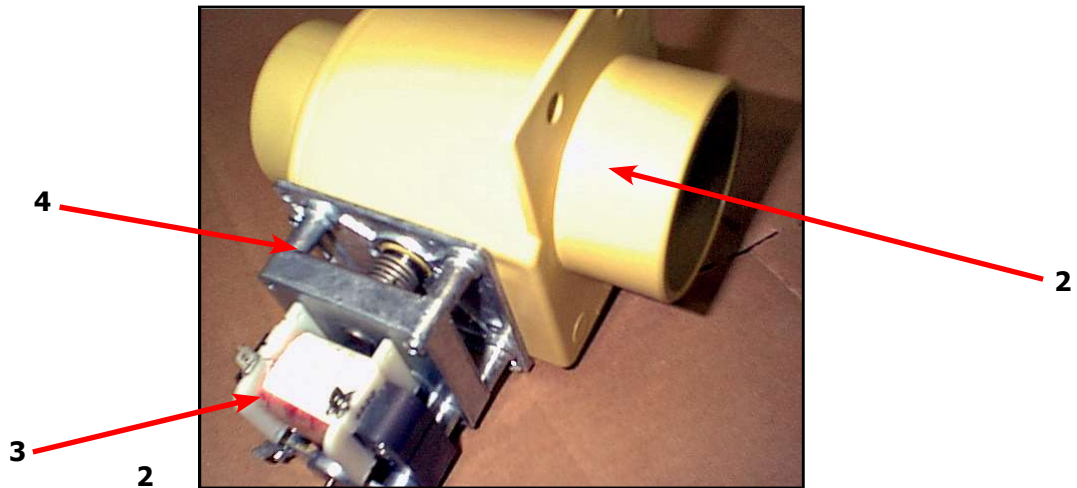

Water Inlet Valve Breakdown

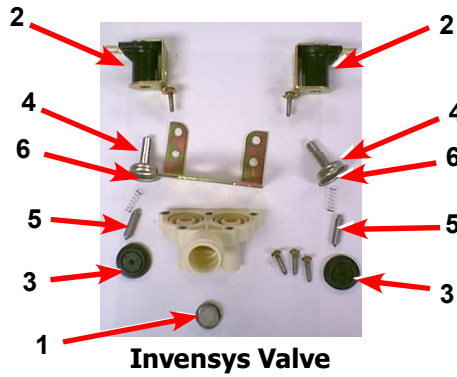

Invensys Valve

Key	Description	Part Number	QTY
*	Valve, Water Inlet (includes 1 thru 6) - Invensys	9379-183-012	2
1	Screen, Inlet end of valve	9555-056-001	2
2	Coil Assy., 120 V Invensys	9089-017-001	2
3	Diaphragm Invensys (EPDM NSF)	9118-049-003	2
4	Guide, Solenoid Invensys	9211-021-002	2
5	Armature Invensys	9015-008-001	2
6	Spring, Armature Invensys	9534-298-001	2
*	Optional Diaphran (Viaton)	9118-049-002	2
*	Wiring Harness	9794-001-001	1

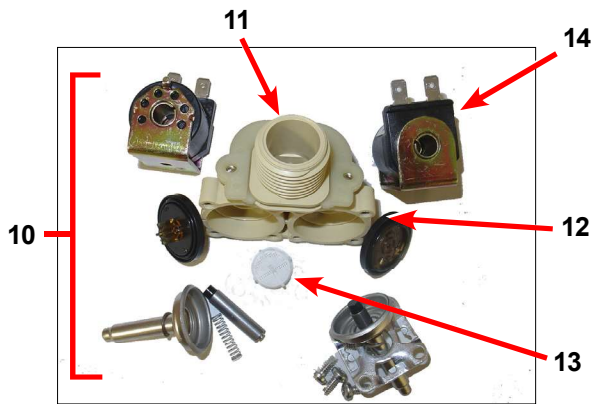

Optional Mueller Valve

Key	Description	Part Number	QTY
10	Dual Coil Water Valve Mueller	9379-192-001	2
11	Valve Water Body Complete (no coil)	9379-192-002	1
12	Diaphragm Mueller	9118-054-001	2
13	Filter Mueller	9183-046-001	1
14	Coil Mueller	9089-051-001	2
16	Diaphragm Assembly Mueller	9785-001-001	1

WSAD Chassis and Drain by Part

Key	Description	Part Number	Qty
1	Base Assy,Frame	9945-109-002	1
*	Outer Tub Assy	9930-140-001	1
*	Cylinder Assembly, (Includes Spider)	9848-120-001	1
3	Back Ass'y, Tub	9962-013-003	1
4	Bolt, 7/16" x 2" Tub Back to Tub	9545-059-002	12
5	Nut, Flange Lock	8640-416-005	12
*	Bolt, 5/8-11 x 1 1/2 Tub to Base, Front	9545-060-001	2
*	Nut, 5/8-11 Wizlok	8640-425-001	2
*	Ring Assy, Tub Mtg-Front	9950-051-004	1
*	Bolt, Top Front Ring 5/8" x 3"	9545-017-016	1
*	Nut WCAD 5/8"	8640-417-005	1
6	Ring Assy.Clamp Tub Mtg.- Rear	9950-056-002	1
7	Bolt, 5/8-11 x 1 1/2 Tub to Base, Rear	9545-060-001	2
8	Nut, 5/8-11 Wizlok	8640-425-001	2
9	Bolt, 5/8-11 x 2 Tub & Rings to Base, Front & Rear	9545-060-004	4
10	Washer	8641-581-038	4
11	Nut, 5/8-11 Wizlok	8640-425-001	4
12	Hose, Overflow	9242-449-004	1
13	Clamp	8654-117-018	2
14	Tube, Over Suds	9242-463-005	1
*	Clamp	8654-117-014	1
15	Hose, Tub to Drain Valve	9242-464-001	1
16	Valve, Drain	9379-187-004	1
*	Bracket, Drain Valve		
*	Screw, Valve to Bracket 5/16-18x1 1/4	9545-014-012	2
*	Nut, 5/16-18	8640-400-003	2
17	Hose, Drain Valve to Tube	9242-457-001	1
*	Clamp, Hose (Drain Valve to Tube)&(Srain Hose to Valve)	8654-117-009	2
*	Screw Tube (Bracket to Base 1/4B x 3/4)	9545-030-002	2
18	Tube Assy, Drain	9915-122-002	1
19	Hose, Vacuum Brkr. to Tub	9242-458-001	1
	Clamp	8654-117-014	2
20	Hose, Pressure Switch	9242-175-005	1

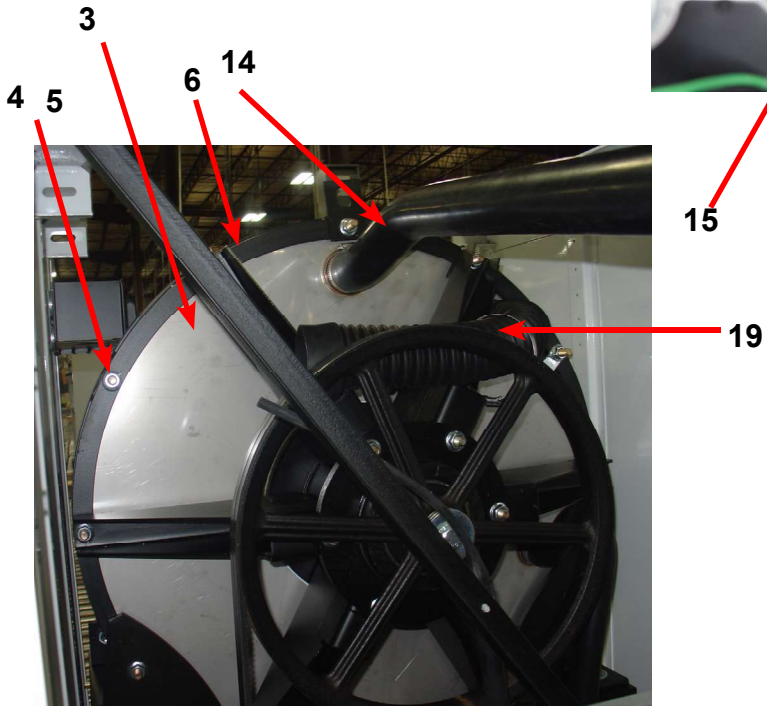
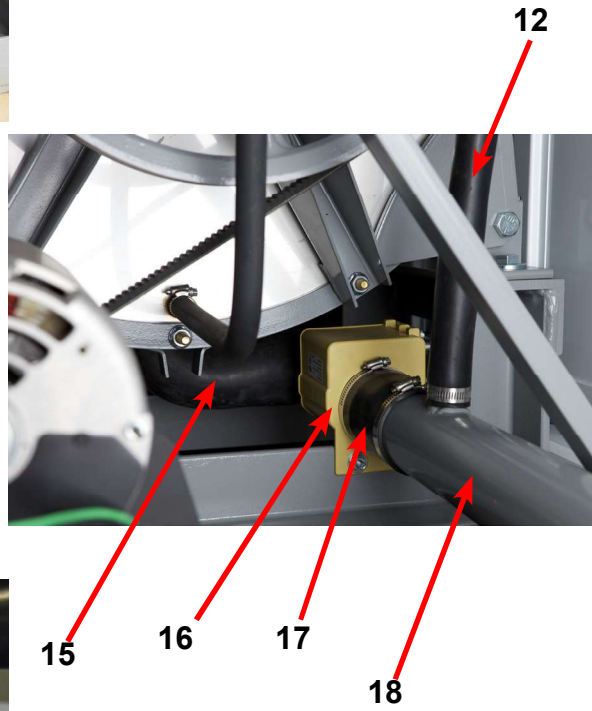
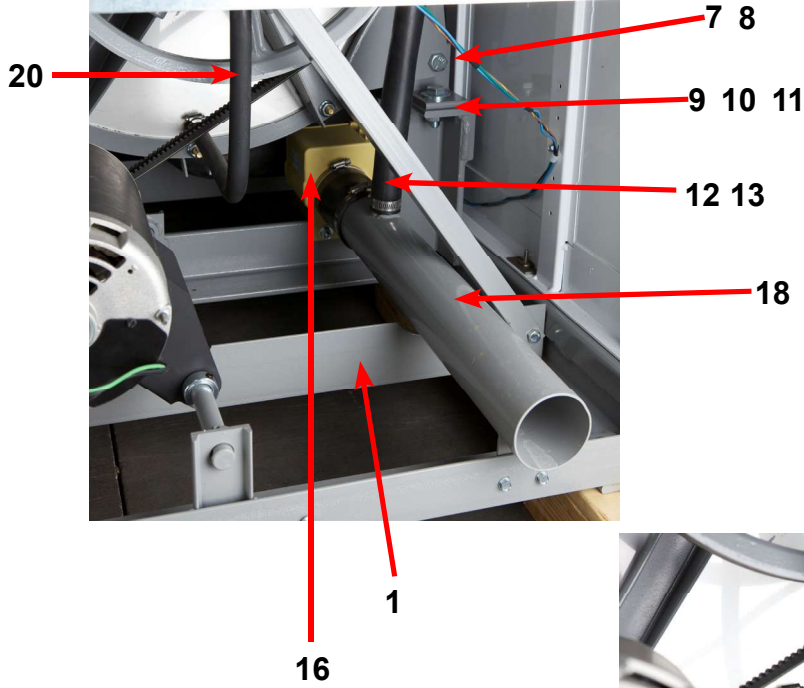
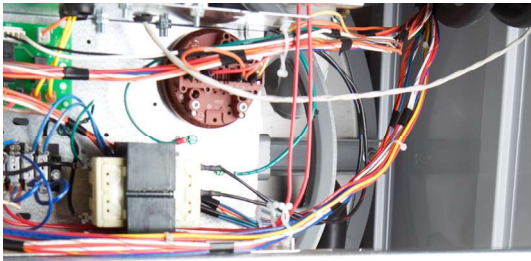

WSAD Electrical Components, Control

Key	Description	Part Number	Qty
1	Trough Assy,Controls 208-240 volt	9857-156-001	1
	Trough only	9839-015-001	1
2	Transformer, Control (208/230/60 Hz In 115,150VA Out Volts)	8711-004-001	1
*	Wire Assembly, Red 28"	8220-062-025	2
*	Screw, #10B x 1/2	9545-008-026	4
*	Lockwasher #10	8641-582-006	4
*	Wire Assembly, BLK/BLU	8220-001-231	1
*	Terminal Block Assy, POWER	9897-034-001	1
*	Screw, Mtg 8Bx3/4"	9545-045-007	2
*	Strip, Terminal Marker	9558-027-001	1
*	Wire Assembly-Jumper, BLU/WHT	8220-090-009	1
3	Transformer, Step Down (120VAC In, Sec-1, 24.3, Sec-2, 2.3VAC)	8711-010-001	1
*	Harness-extention, Transformer	9627-826-001	1
*	Screw, 8B x 1/4	9545-045-001	2
*	Lockwasher #10	8641-582-005	2
*	Wire Assembly, P12, Red 7"	9631-381-018	1
4	PCB assembly Relay Main	9473-006-001	1
*	Wiring Harness, Door Lock P15/P4	9627-816-002	1
*	Wiring Assembly Yel. 32" P14 & P13	8220-064-023	2
5	Wiring Harness, Drain,Thermo,DoorSol P17	9627-820-001	1
6	Wiring Harness WaterValve/P19	9627-795-004	1
7	Wiring Harness P8/P16	9627-819-001	1
*	Wiring Harness P20/P21	9627-818-001	1
8	Pressure Switch	9539-490-001	1
9	Harness Assembly, Pressure Switch	9627-822-001	1
*	Electronic Pressure Swtich Kit	9732-314-001	*

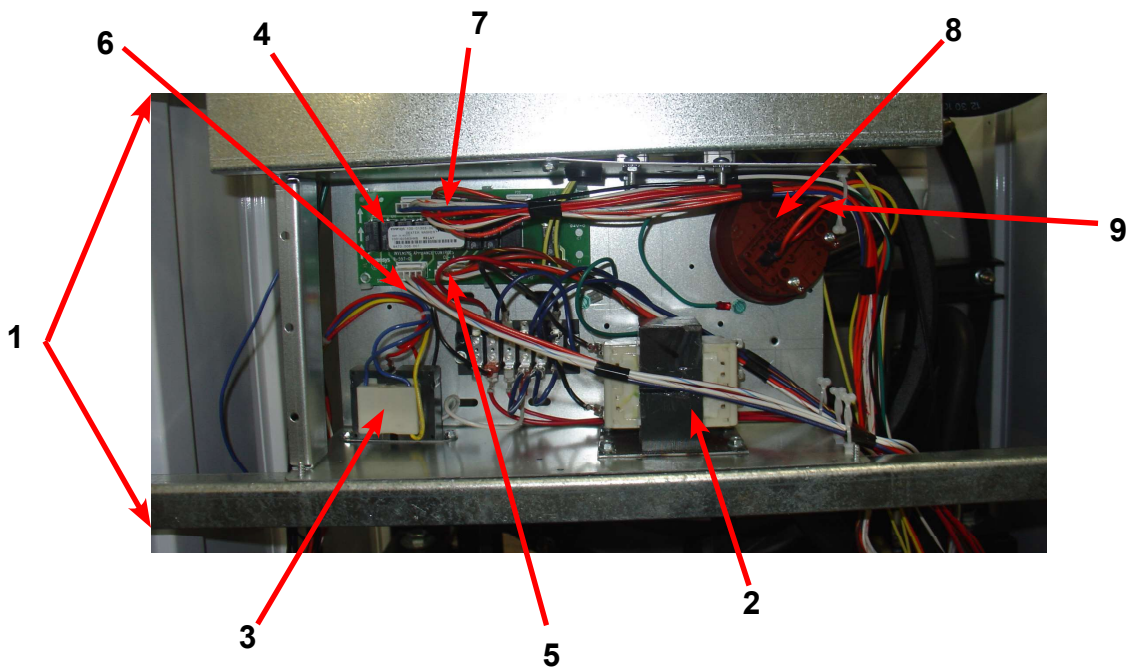

WSAD Electrical Components, Upper

Key	Description	Part Number	Qty
1	Terminal Block Assy, POWER	9897-033-002	1
*	Screw, Mtg 6ABx3/4"	9495-031-010	2
2	Strip, Terminal Marker	9558-025-001	1
3	Terminal, Lug-Solderless (Ground)	8652-134-001	1
*	Screw, 10-32TTx1/2 Green (Control Trough)	9545-008-027	
*	Wiring Harness Power Terminal To VFD & Control Transformer and ground wire	9627-747-002	1
4	VFD Delta drive 208-240 volt	9375-015-014	1
*	Cable, Data Communication	9806-015-002	1
*	Wiring Assembly Yel. 32"	8220-064-023	2
5	Braking resistors (200 ohm)	9483-004-002	3
*	Wire Assembly, BLK (Breaking Resistors)	8220-118-002	2
*	Wire Assembly-Jumper, BLK (Breaking Resistors)	8220-117-002	2
*	Label Fuse 1.5 amp Rear	8502-716-001	
*	Fuse-1.5a	8636-018-001	1
6	Fuseholder-Assembly	9200-001-002	1
*	Circuit Breaker (optional) 1.5 AMP	5198-211-004	1

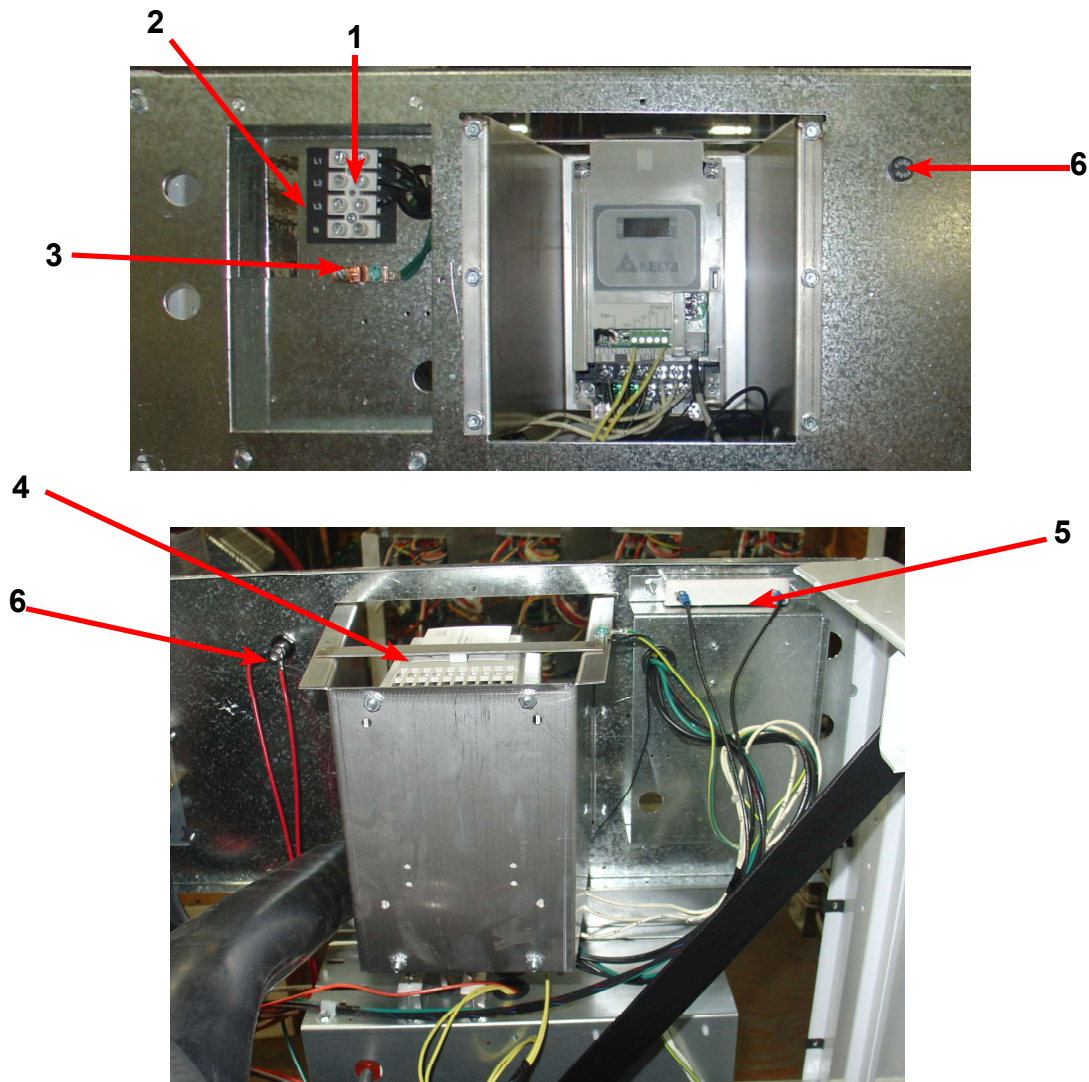

WSAD Front Panel Control Group Part

Key	Description	Part Number	Qty
*	Nameplate,Control Panel (one piece)	9412-143-001	1
1	PCB assembly Control /Display	9473-009-005	1
*	Spacer Pushbutton (Micro)	9538-178-001	1
*	Retainer Pushbutton (Micro)	9486-150-001	1
*	Nut Hexelasticstop #4-40	8640-424-002	2
*	Pushbutton Control (coin)	9035-060-003	1
*	Spacer Plastic #6x9/16	9538-157-018	5
*	Nut Elasticstop #6-32	8640-411-002	4
*	Nut-Hexkeps, #6-32	8640-411-003	1
2	Harness LEDPCB	9627-821-001	1
3	Harness Doorlock, Switches	9627-816-002	1
4	PCB assembly Mode lights	9473-005-001	1
*	Spacer Plastic #6x9/16	9537-157-018	2
*	Nut Hexkeps #6-32	8640-411-003	2
5	Light, LED,ADD BLEACH Assembly	9794-001-001	1
*	Spacer Plastic #6x9/16	9538-157-018	2
*	Nut Hexeps #6-32	8640-411-003	2
*	Switch Assembly Emergency Stop (includes Wire Harness)	9732-223-002	1
*	Spacer Plastic #8x5/16 E-Stop	9538-157-020	2
*	Nut HexKep #8-32 E-Stop	8640-412-005	2
6	Solenoid Ass'y, Door Locking See Door Lock Group for Parts Breakdown)	9922-011-009	1
*	Hex Nuts (mounting solenoid assy. To Control)	8640-412-005	3
7	Battery	8612-001-001	1
*	Plate to mount e-stop button	9452-725-001	1

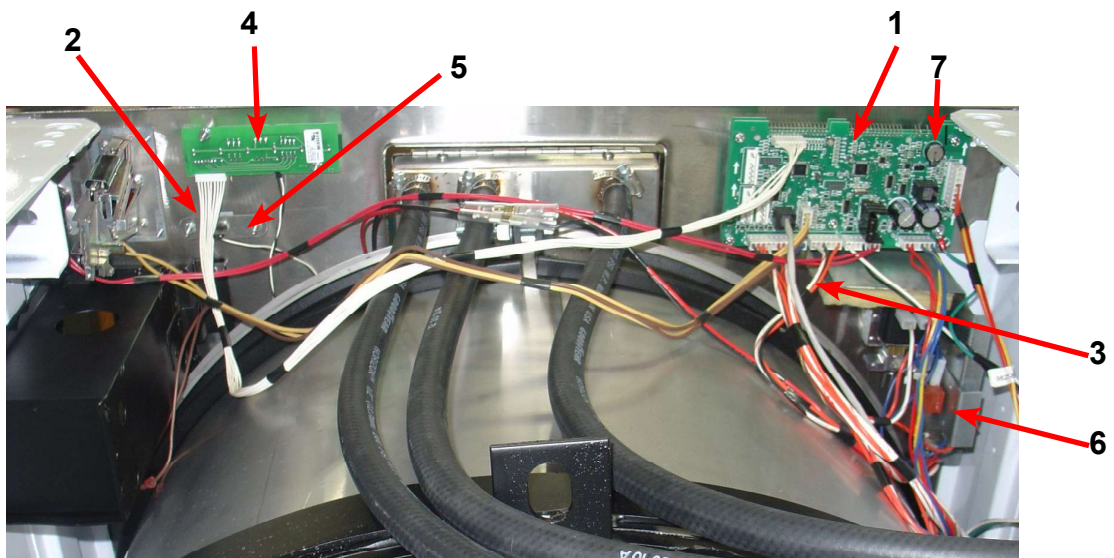

WSAD Labels and Diagrams by Part

Key	Description	Part Number	Qty
*	Wiring Diagram, Coin	9506-123-001	1
*	Wiring Schematic, Coin	9506-122-001	1
*	Wiring Diagram (Easy Card)	9506-109-001	1
*	Wiring Schematic, (Easy Card)	9506-108-001	1
*	Transient Voltage Surge Suppressor Informational	8507-330-001	1
1	Label High Voltage Warning	8502-614-005	1
2	Label Fusing & Installation	8502-619-004	1
3	Label Warning Risk of Injury	8502-722-001	1
4	Label Warning Door Opening	8502-723-001	1
*	Booklet Owners	8514-198-001	1
5	Label Top Dispenser	8502-687-001	1
6	Label-Connection Electrical	8502-649-001	1
7	Label-"EXPRESS", Soap Dispenser	8502-715-001	1

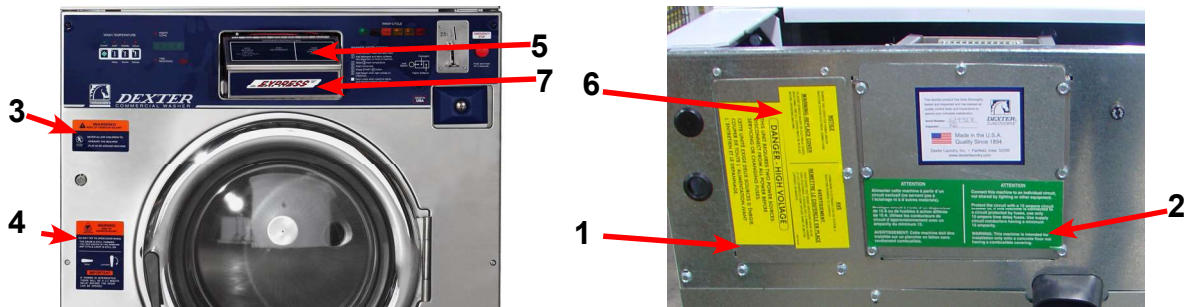

WSAD Coin Handling by Part

Key	Description	Part Number	Qty
7	Vault, Assy	9942-028-003	1
*	Screw, 10B x 1/2" Vault Mtg	9545-008-026	4
8	Coin Acceptor Optical	9021-092-002	1
*	Coin Acceptor chute without penny rejector (Standard)	9119-025-002	1
10	Coin Acceptor chute with penny rejector (Optional)	9119-025-001	1
*	Screw, Acceptor Mtg	9545-053-002	4
*	Button Coin Return Retainer	9486-145-001	1
9	Micro Switch, Coin Count	9539-466-005	1
*	Harness Coin Switch	9627-817-001	1

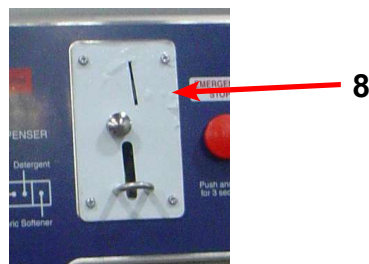
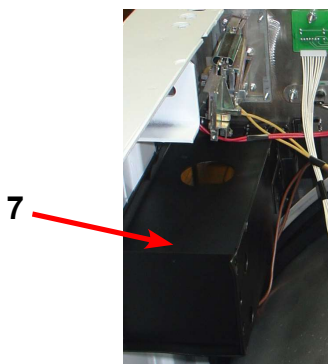

Coin Handling Group

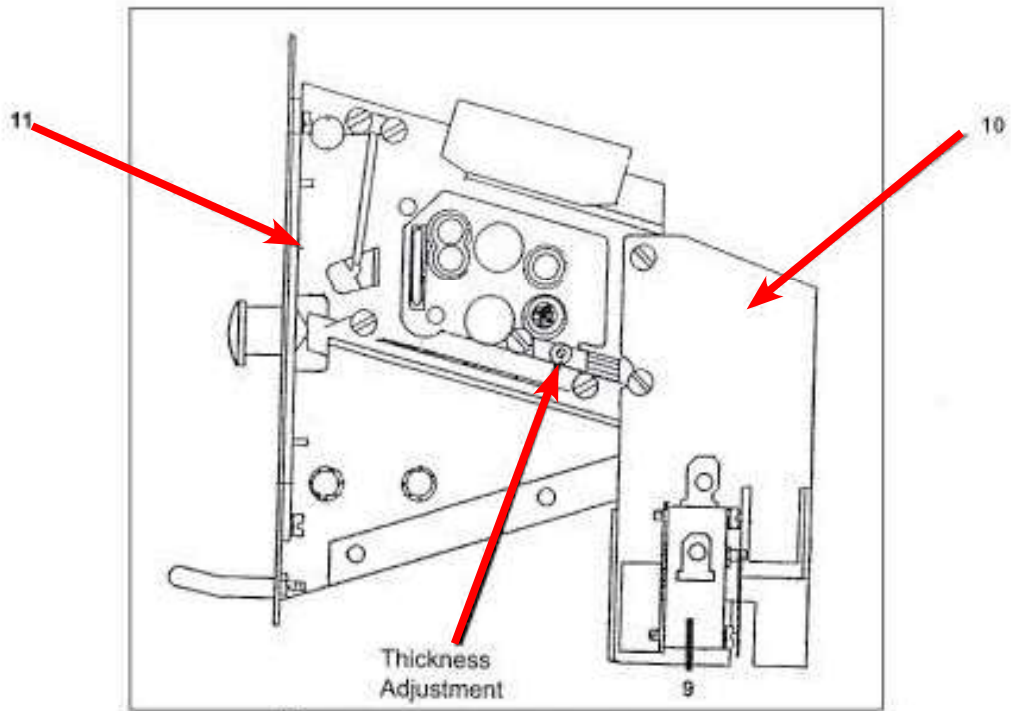

#8 COIN ACCEPTOR - right side

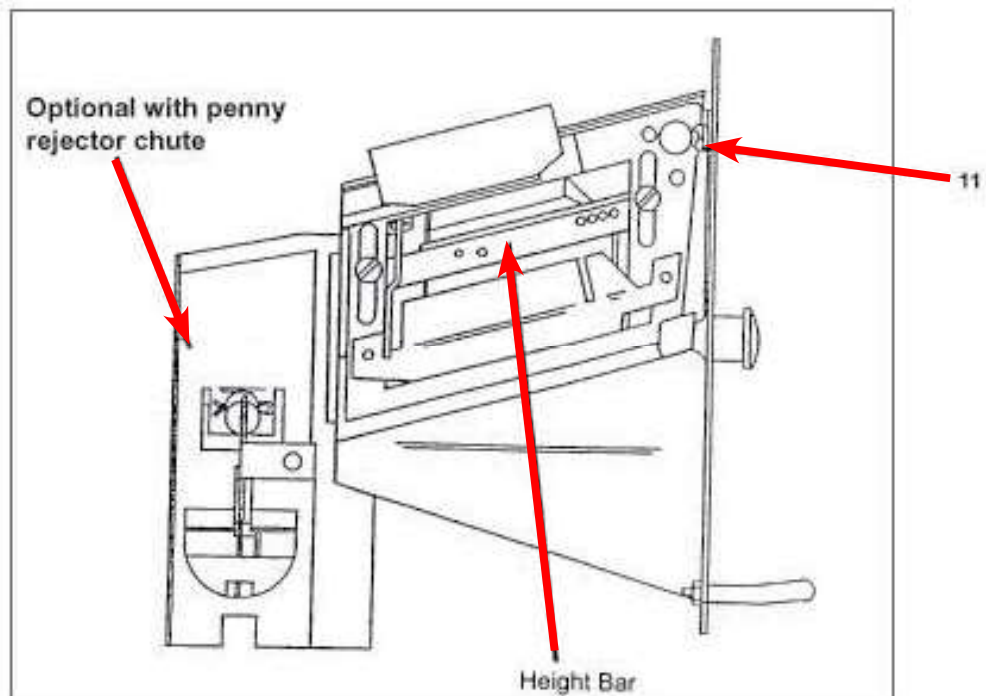

WSAD Kit - Electronic Acceptor

Key	Description	Part Number	Qty
*	KIT - Electronic Acceptor Conversion for WSAD (UAS & Canada) Contact the Dexter Factory for other Countries	9732-213-007	1
*	Electronic Coin Acceptor (USA & Canada)	9021-010-001	1
*	Harness for Electronic Coin Acceptor	9627-845-001	1
*	Transformer 120/18VAC	8711-015-001	1
*	Wire Assembly - Blue	8220-001-338	1
*	Wire Assembly - Orange/White	8220-001-235	1
*	Wire Assembly - White/Blue	8220-062-001	2
*	Nut - Hex Elastic Stop	8640-411-002	2
*	Screw, Torx	9545-053-002	8
*	Acceptor Retainer	9486-155-001	2
*	Label, Informative	6102-017-001	1
*	Label, Warning	8502-730-001	1
*	Instructions, Installation	8507-367-002	1

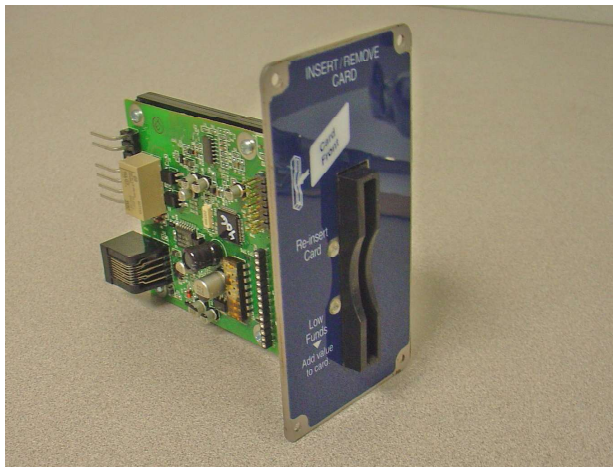

WSAD Integrated EasyCard by Part

Key	Description	Part Number	Qty
*	Panel Assembly (panel only)	9989-506-001	1
*	Nameplate,Control Panel (one piece)	9412-152-001	1
*	Harness, EasyCard V&A-reader ALL MODELS	9627-827-002	1
*	Card Reader Assembly Complete	9797-008-001	1
*	Card Reader (IC reader only)	9797-007-003	1
*	Cable Assembly 4 twisted pair 12' shld/unshield reader to rear of machine	9806-013-002	1
*	Wiring Schematic, Easy Card	9506-108-001	1
*	Wiring Diagram (Easy Card)	9506-109-001	1

Section 11:

50 Hz Washer

Models

Parts in this section used only in these models. All other parts are same as standard 60 Hz pages.

Transformers and Coin Handling -21 Models

KEY	Part Description	WSAD30KCS-21CR	QTY
*	Wire Assembly -Orange/White	8220-001-235	1
*	Wire Assembly -Blue	8220-001-338	1
*	Label-Warning, Electronic Coinacceptor	8502-730-001	1
*	Lockwasher-Exttooth,#6	8641-582-005	4
1	Transformer-120/18zVAC,5VA	8711-015-001	1
2	Transformer, Control	8711-004-002	1
3	Transformer, Secondary	8711-010-002	1
4	Acceptor-Coin,Electronic	9021-013-001	1
*	Wiringlabel-Schematic	9506-166-001	1
*	Wiringlabel-Diagram	9506-167-001	1
*	Screw-Hx 10bx1/4	9545-008-001	7
*	Screw-Hx ,8bx1/4	9545-045-001	6
6	Harness-Electronic Coin Acceptor	9627-845-001	1
*	Controlsassembly -Trough	9857-156-004	1

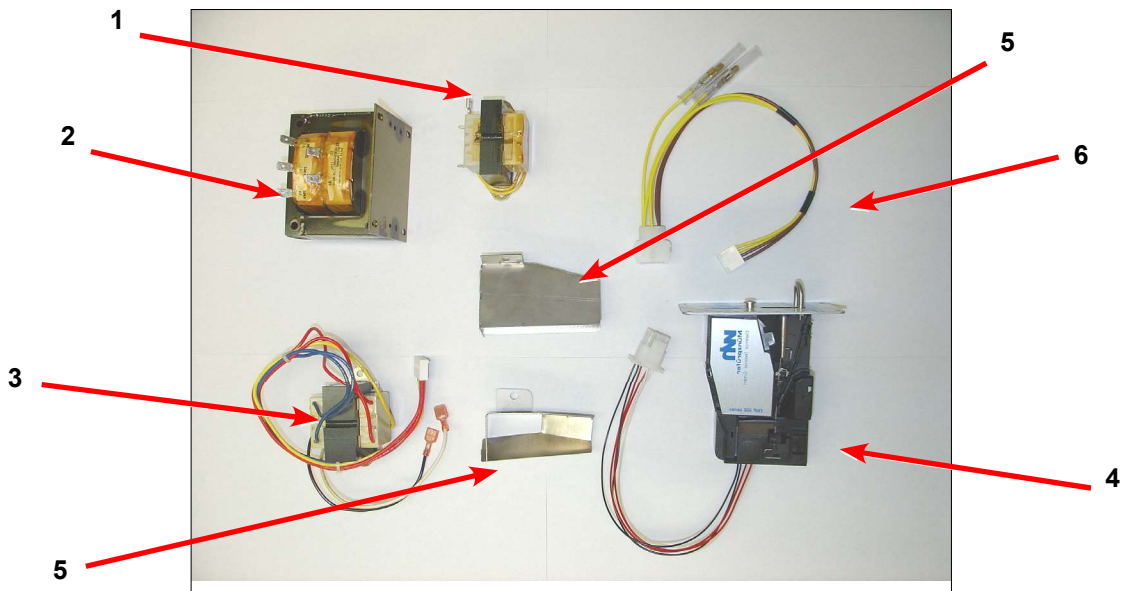

Wiring Schematic for 50hz Washer -21CR

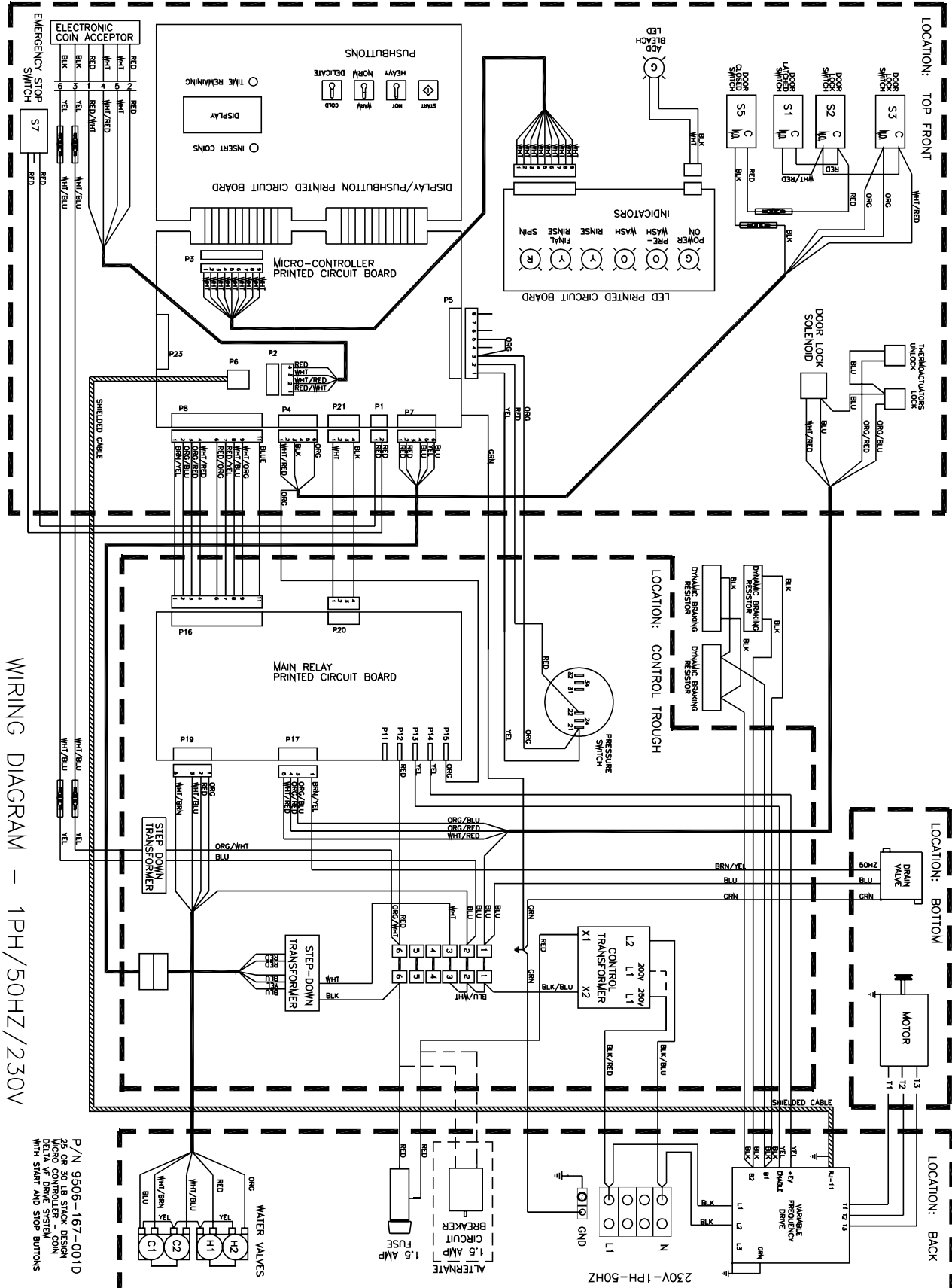

WIRING DIAGRAM - 1PH/50HZ/230V

P/N 9506-167-001D
 P/N 9506-167-001D
 MICRO CONTROLLER
 DELTA V⁺ DRIVE SYSTEM
 WITH START AND STOP BUTTONS

Wiring Diagram for 50hz Washer - 21CR

230V-1PH-50HZ

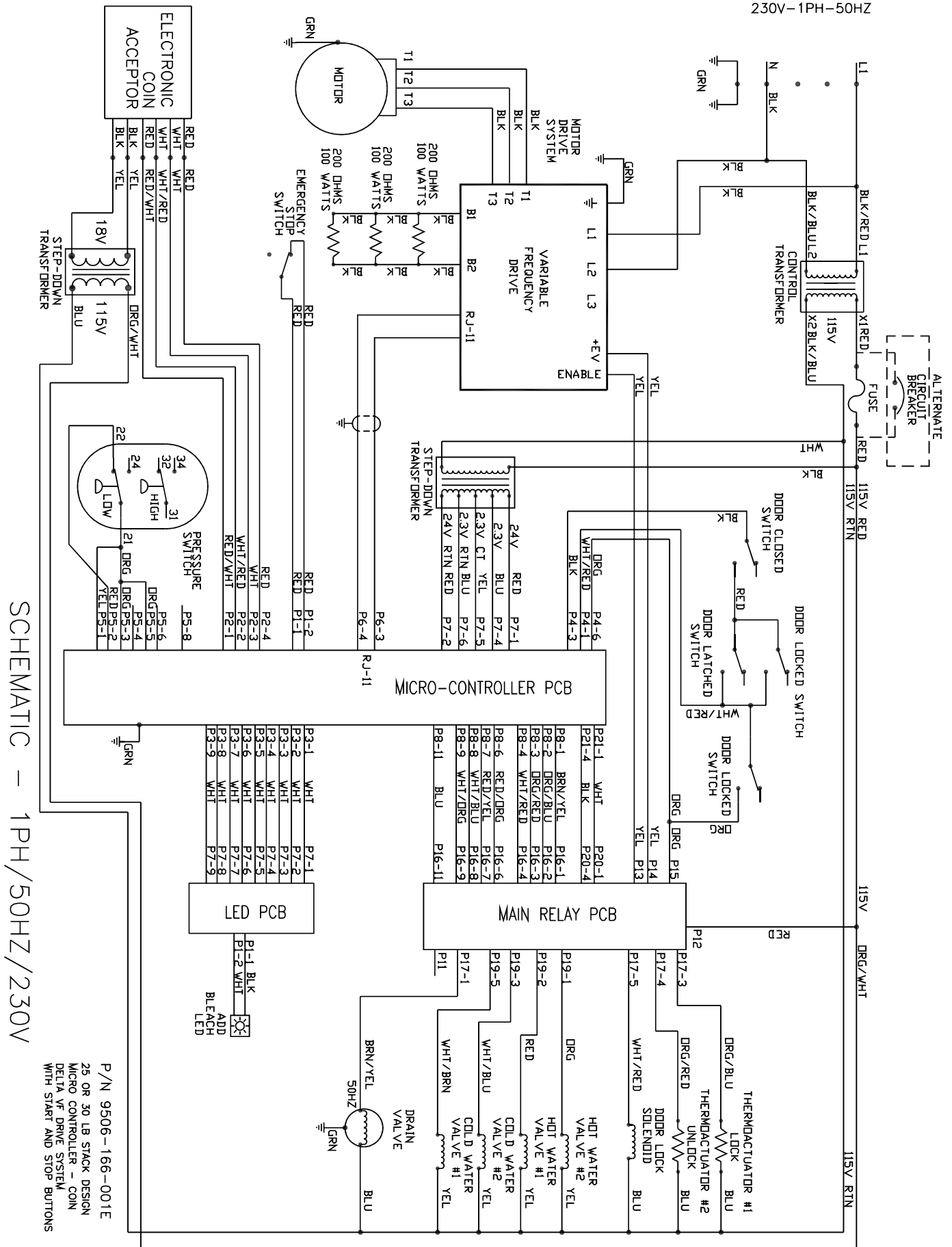

SCHEMATIC - 1PH/50HZ/230V

P/N 9506-166-001E
 25 OR 30 LB STACK DESIGN
 MICRO CONTROLLER - COIN
 DELTA V.F. DRIVE SYSTEM
 WITH START AND STOP BUTTONS