



DEXTER.
LAUNDRY

**USE THE BLUE TABS LOCATED ON THE
RIGHT AND LEFT SIDES OF THE FOLLOWING
DOCUMENT TO ADVANCE TO EACH SECTION.**

Kits, Assemblies, & Common Parts

Description	Part Number
Kit T80 Bottom Exhaust	9732-348-001
LP to Natural Gas Conversion for White Rodgers	9732-142-004
Kit, Optional Replacement for Round Switch 9539-492-001	9732-351-001
Temperature Probe	9501-004-002
Kit-30/50/80 OPL, PCB-Controller	9732-249-001
Ignition Control Box	9857-182-001
Electrode Assembly, Ignition	9875-002-003
Thermostat, Hi-Limit	9576-203-002
Thermostat, Overtemp	9576-207-006
Motor Run Relay	5192-299-002
Transformer	8711-007-002
Lint Screen	9822-031-002
Air Flow Switch	9539-461-009
Door Switch	9539-492-001
Motor Belt	9040-076-003
Tumbler Belt	9040-073-012
Tension Arm Complete	9861-024-002
Spider/Trunnion	9873-008-001
Door Handle	9244-082-001



Section 5: Dryer Parts Data

DCBD80HC_-10BD
DN0080NC-10EB2R

Dryer Cabinet Group

Key	Description	T80	
1	Loading Door Complete SS/Brushed SS/Blk	9960-305-001	1
1	Loading Door Complete Wht/Brushed SS/Blk	9960-305-003	1
2	Door Assy, Loading (Ring only) Brushed SS	9960-284-002	1
2	Door Assy, Loading (Ring only) Blk (after serial D1.22290.005)	9960-320-004	1
3	Plate Assy, Hinge (SS)	9982-368-001	1
3	Plate Assy, Hinge (Wht)	9982-368-003	1
*	Cover-Hinge Back, Black	9074-340-002	1
*	Screw-10Bx3/8, Black	9545-008-010	2
*	Screw Hinge to Door	9545-012-015	4
*	Nut, Hinge to Door	8640-413-002	4
4	Glass, Door	9212-002-004	1
5	Gasket, Door Glass (Black)	9206-413-002	1
*	Support Door Glass	9548-117-000	2
6	Gasket, Door Outer Rim (Black)	9206-420-005	1
7	Handle, Loading Door	9244-082-001	1
*	Screw, Handle	9545-018-017	2
8	Stud Door Catch	9531-033-003	1
9	Nut-Hex, #10-32	8640-413-001	1
10	Nut, Acorn	8640-413-003	1
*	Catch, Loading Door	9086-015-002	2
*	Rivit	8638-190-009	4
11	Strap, Hinge (Black)	9966-014-002	1
*	Plate Assy-Backup, Hinge	9982-369-001	1
*	Reinforcement-Front panel	9817-003-001	1
12	Screw-Phillips, 10-32x1/2 Chrome	9545-012-003	8
*	Screw-Phillips-Counter sink, 10-32x1/2 Chrome	9545-012-028	4
13	Screw-Special, Hinge to Door	9545-052-001	1
*	Nut-Allen, 1/4-20	8640-439-001	1
14	Washer-Fiber/Plastic	8641-436-003	1
15	Front Panel Assy (SS)	9454-868-001	1
15	Front Panel Assy (Wht)	9454-868-003	1
16	Screw-Phillips, 10Bx1 3/4	9545-008-014	4
17	Washer-Finish	8641-585-001	4
*	Nut-Spring	8640-399-001	4
*	Insulation-Front Panel, Top Half	9277-058-001	1
*	Insulation-Front Panel, Bottom Half	9278-058-002	1
18	Label-Warning	8502-753-001	1
19	Plug-Front Panel	9456-050-001	1
*	Switch-Door Closed	9539-492-001	1
*	Wire-Assy, Blk	8220-063-026	1
*	Wire-Assy-Blu	8220-063-009	1
*	Cover-Door Switch	9074-351-001	1
*	Nut-#10-32unf, 2B	8641-413-002	2
*	Cabinet Touch Up Paint (White)	9472-001-013	1

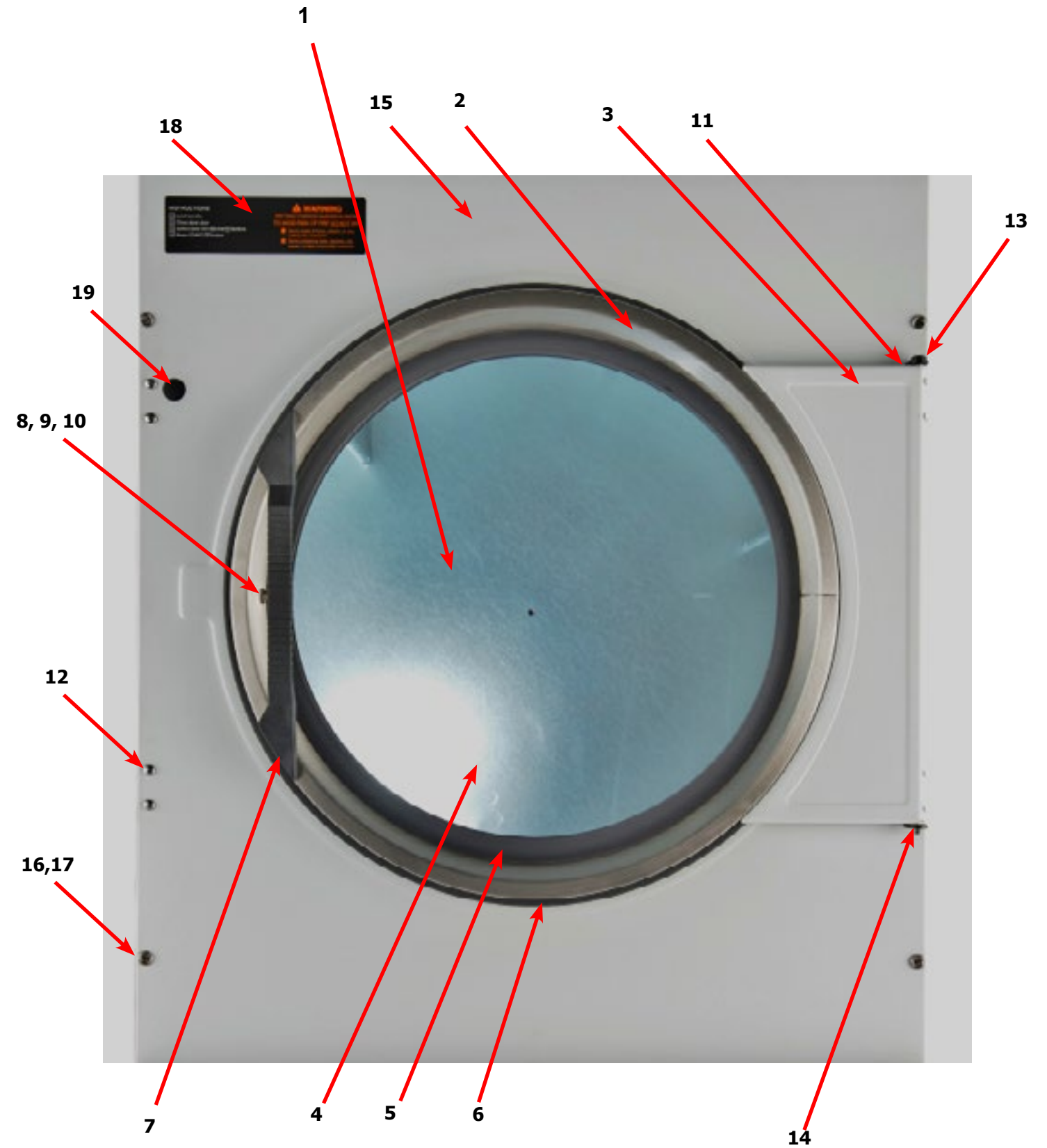

Dryer Cabinet Group Continued

Key	Description	T80	QTY
1	Nameplate - Dexter Dryer Black	9412-196-001	1
2	Door Assy-Upper, OPL (SS)	9960-292-001	1
2	Door Assy-Upper, OPL (Wht)	9960-292-003	1
*	Bracket-Hinge	9029-224-001	2
*	Rivit- 3/16, Hinge to Door	9491-009-001	2
*	Rivit- 3/16, Hinge to Cabinet	9491-009-001	AR
3	Trim-Upper Service Door, Black	9578-096-002	1
4	Screw-Phillips, 10Bx3/8, Black	9545-008-010	4
5	Screw-Phillips, 10Bx1 3/4	9545-008-014	2
6	Washer-Finish	8641-585-001	2
*	Nut-Spring	8640-399-001	2
7	Membrane Switch	9801-103-001	1
8	Kit-30/50/80 OPL, PCB-Controler	9732-249-001	1
*	Spacer-#6 x 1/2	9538-157-015	4
9	Nut- #6-32	8640-411-003	4
10	Wire Assy-GRN, 24"	8220-137-001	1
11	Fuse, .600MA/250V	8636-024-001	1
12	Support-Upper Service Door	9548-288-002	1
13	Clamp-Tube	9079-121-002	2
14	Nut, #6-32	8640-411-003	2
15	Clamp-Cable, 1/2"	8654-126-004	1
16	Nut, #6-32	8640-411-003	1
17	Insulation	9277-041-016	1
*	Harness-Control	9627-770-003	1
*	Harness-Temp Probe	9627-679-002	1



7 4 2 1 3 5, 6

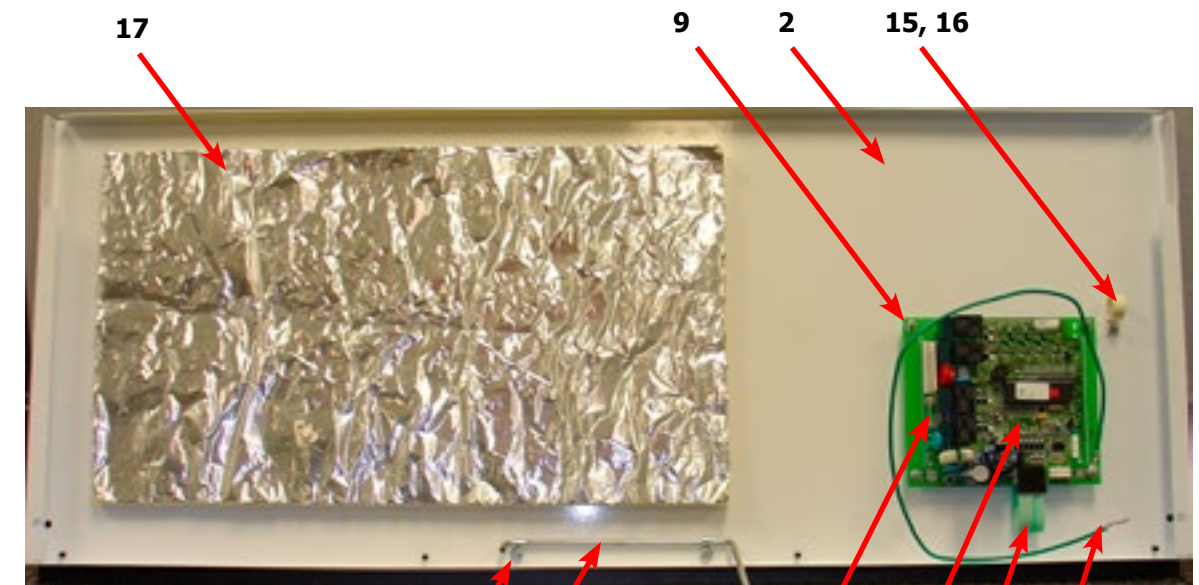

17 9 2 15, 16

13, 14 12 11 8 7 10

Dryer Cabinet Group Continued

Key	Description	T80	QTY
1	Door-Lower Service, OPL, SS	9108-127-001	1
1	Door-Lower Service, OPL, Wht	9108-127-003	1
2	Handle-Door, Lower Service, Black	9244-088-002	1
3	Screw-Phillips, 10Bx3/8, Black	9545-008-010	5
4	Handle-Door, Lower Service OPL	9244-084-002	1
5	Trim-Lower Kick, Black	9578-097-002	1
6	Screw-Phillips, 10Bx3/8, Black	9545-008-010	4
7	Screen Assy, Lint	9822-031-002	1
8	Switch-Door Closure (Round)	9539-492-001	1
8	Switch-Door Closure (Square)	9539-501-001	1
*	Kit, Optional Replacement for Round Switch 9539-492-001	9732-351-001	1
9	Hinge-Door, Lower	9243-082-001	1
10	Screw-5/16, 10ABx3/8	9545-008-024	5
11	Bracket-Door Switch	9029-226-001	1
*	Rivit, 1/8 Low Profile	9491-009-004	2
12	Bracket-Chain	9029-223-001	2
*	Rivit, 1/8 Low Profile	9491-009-004	8
13	Hook, "S" Type	9248-022-002	4
14	Chain-Lower Service Door	9099-012-006	2
*	Leg, Leveling 1/2"	8544-006-001	4
*	Leveling Leg Wrench	8545-061-002	1

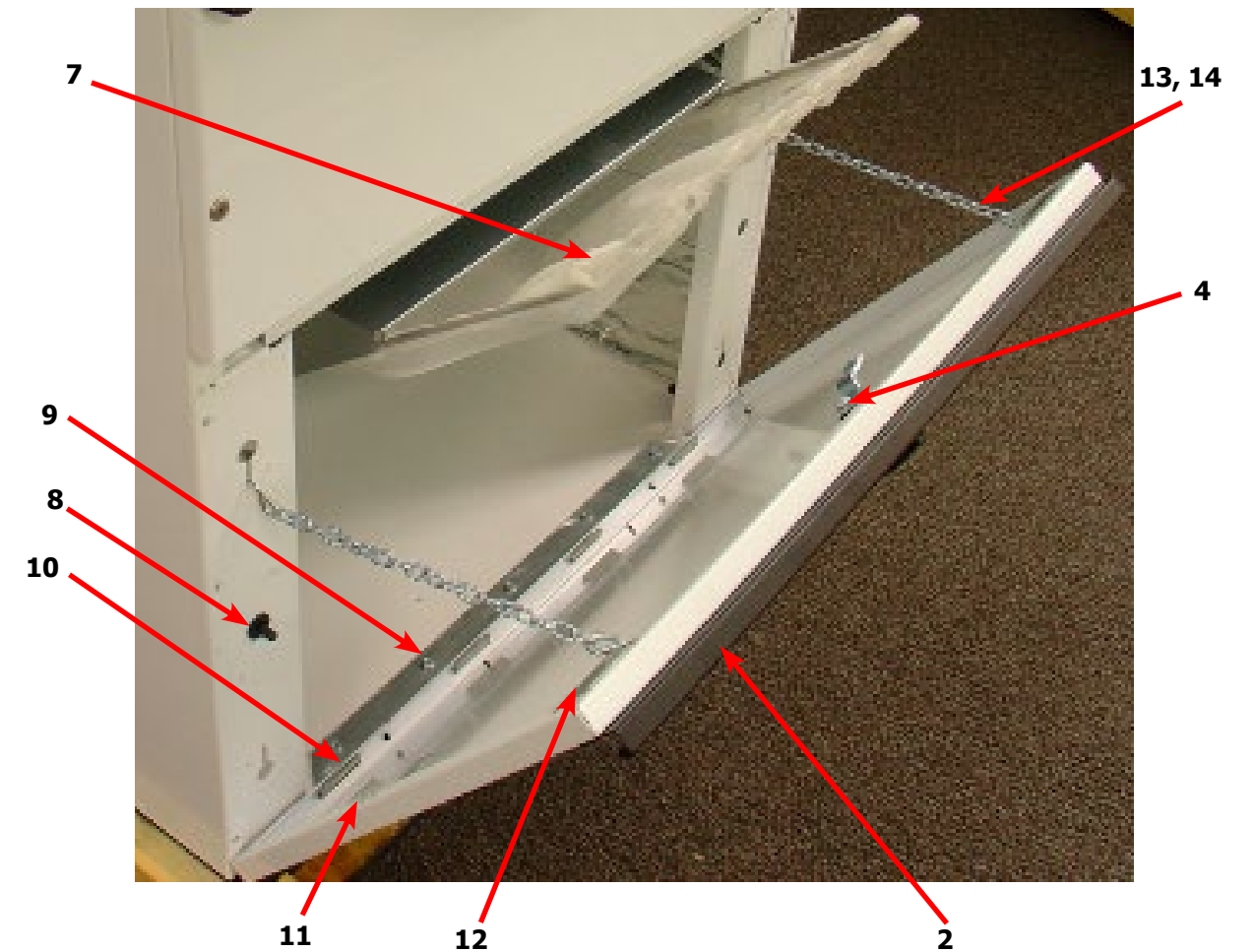
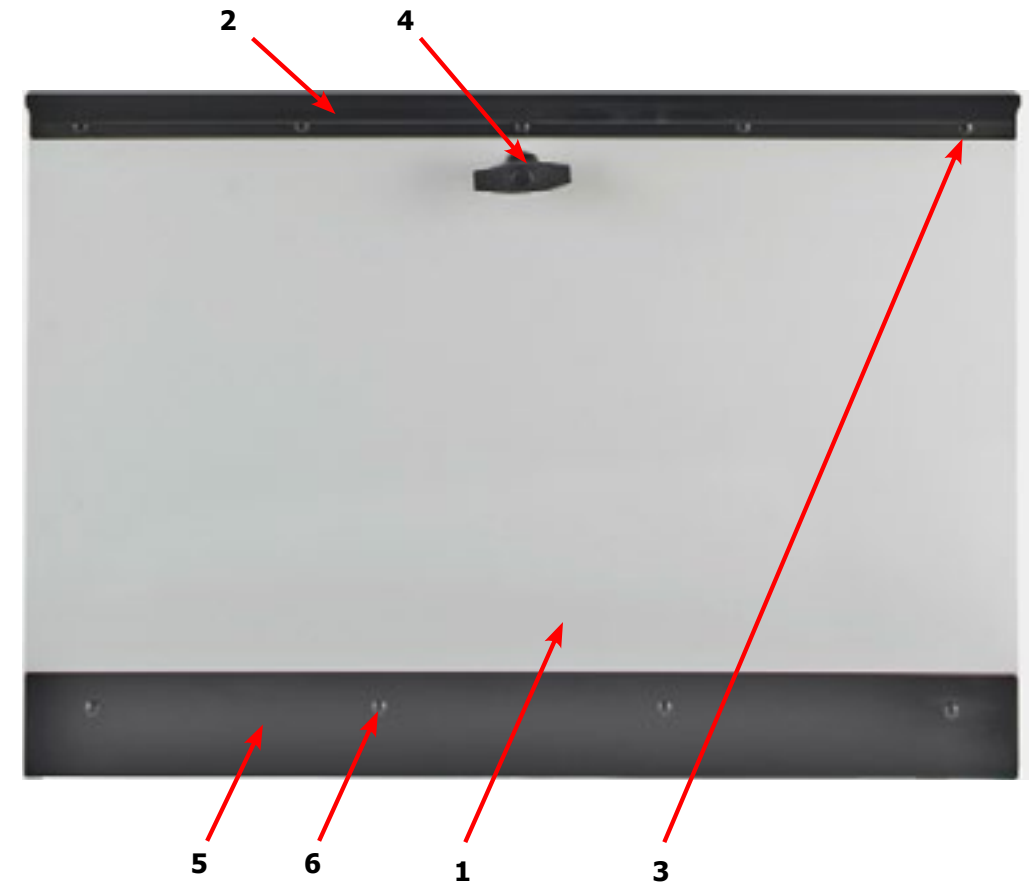

Dryer Cabinet Group Continued

Key	Description	T80	QTY
1	Insulation, Upper service Door	9277-041-016	1
2	Insulation, RH Burnner	9277-041-023	1
3	Insulation Tumbler Area, above Baffel	9277-041-021	2
4	Insulation Tumbler Area, below baffel	9277-051-004	6
5	Insulation Lint Compartment	9277-041-025	2
*	Screen Assy, Lint	9822-031-002	1
6	Switch-Door Closure (Round)	9539-492-001	1
6	Switch-Door Closure (Square)	9539-501-001	1
7	Hinge-Door, Lower	9243-082-001	1
8	Screw-5/16, 10ABx3/8	9545-008-024	AR
9	Lint Hood-Back	9240-044-001	1
10	Nut Wizlock, 8-32	8640-412-004	6
11	Lint hood, LH	9240-046-001	1
12	Lint hood, RH	9240-046-002	1
13	Lint hood, Top	9240-045-001	1
14	Screw, 5/16- 10ABx3/8	9545-008-024	14
15	Impeller, w/set screws	9278-037-003	1
16	Harness -Temp Probe	9627-679-002	1
17	Wire Nut, #71B	8640-276-005	2
18	Temp Probe	9501-004-002	1
19	Screw-Phillips, 8Bx1/4	9545-045-005	1

50Lb & 80Lb Temp Probe

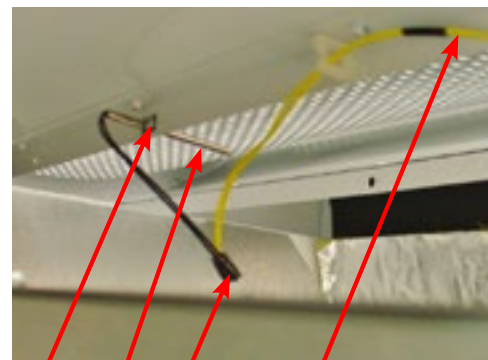

19 18 17 16

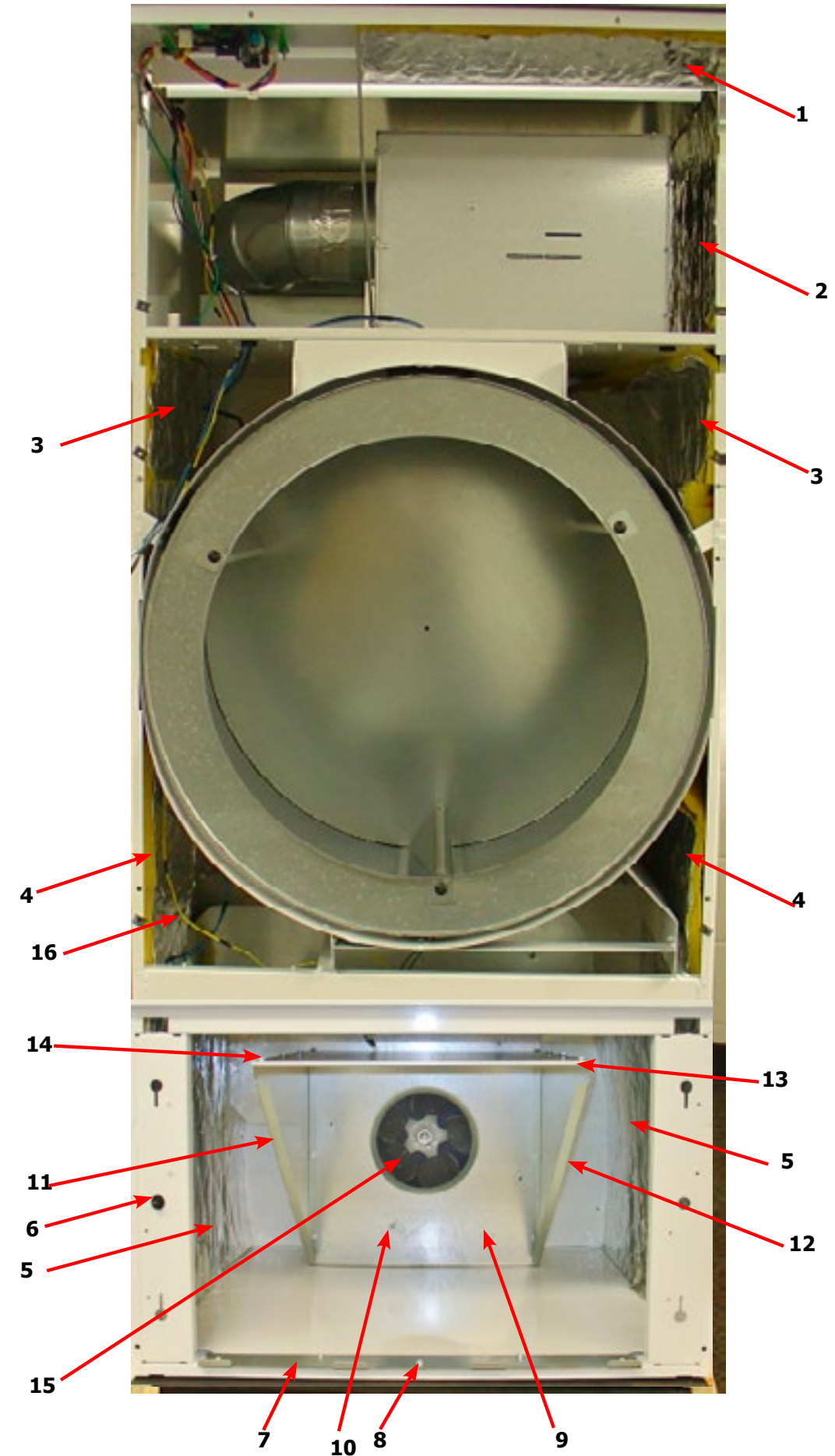

Dryer Modular Cabinet Group (After Serial D1.23090.024)

Key	Description	T80	QTY
1	Cabinet Base Assembly	9945-162-001	1
*	Lower Back Panel Assembly	9989-716-002	1
2	Lower Cabinet RH Side Panel	9444-091-003	1
3	Lower Cabinet LH Side Panel	9444-091-004	1
4	Lower Cabinet Front Channel	9081-217-001	1
*	Upper Back Panel Assembly	9989-717-002	1
5	RH Middle Side Panel Assembly	9989-718-003	1
6	LH Middle Side Panel Assembly	9989-718-004	1
7	Cabinet Top Assembly	9961-163-002	1
8	RH Baffle	9049-129-001	1
9	LH Baffle	9049-129-002	1
*	Baffle Stiffener Angle	9003-384-001	2
10	RH Upper Side Panel	9444-095-003	1
11	LH Upper Side Panel	9444-095-004	1
12	Upper Cross Brace	9046-104-001	1
*	Heavy Hex Nut 7/16-14	8640-416-001	6
*	Spring Lockwasher 7/16	8641-582-013	6
*	10abx3/8 Screw	9545-008-024	28
*	Large Head Pop Rivet	8638-190-028	4
*	3/16 Blind Rivet	9491-009-001	111
*	Wht 3/16 Blind Rivet	9491-009-005	54
*	Hex kep Nut 1/4-20unc, 2b	8640-414-006	10
*	LH Rear Side Angle	9003-326-002	1
*	RH Rear Side Angle	9003-327-002	1

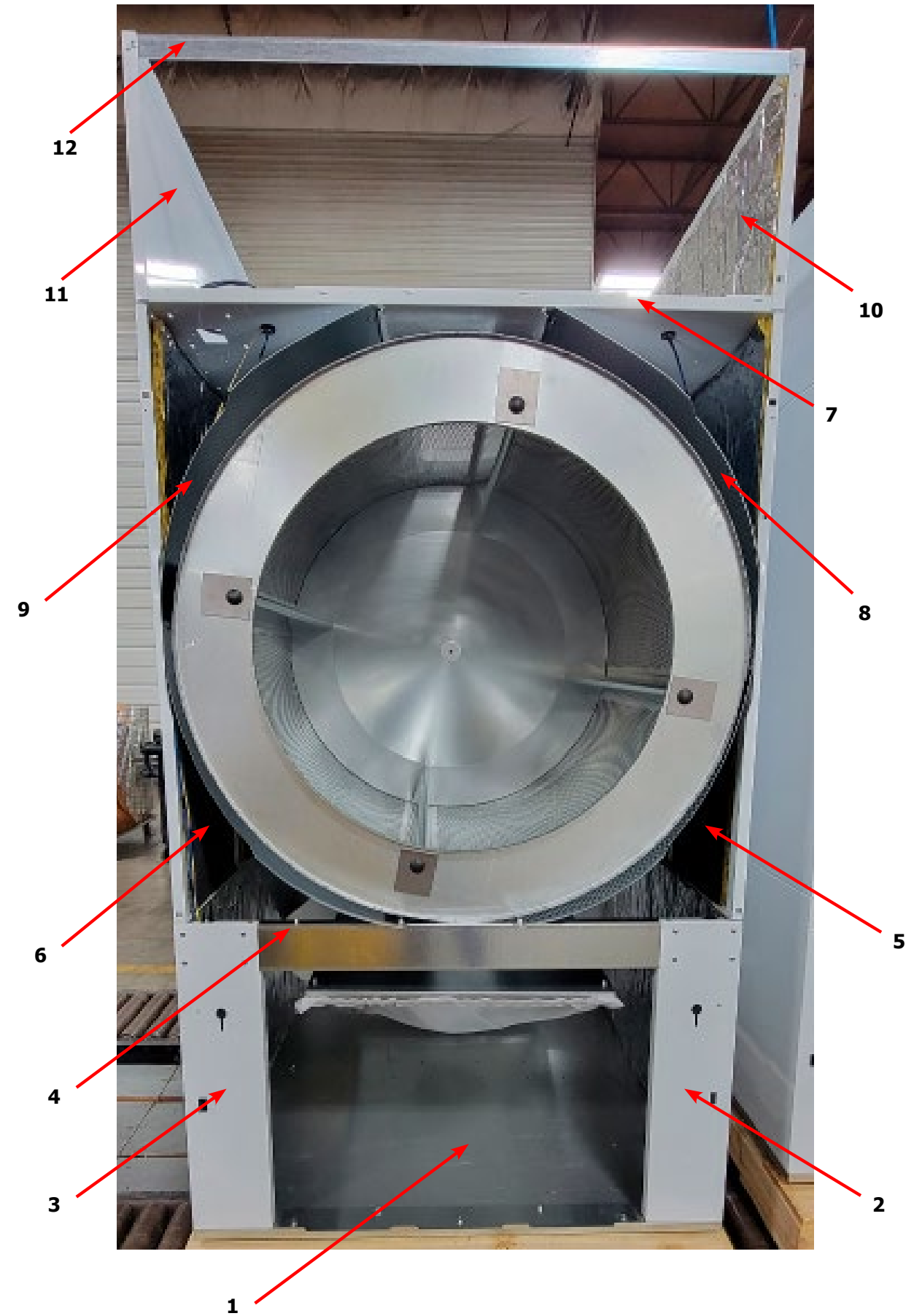

Dryer Rear View 80 Lb Reversing

Key	Description	T-80	QTY
1	Plate-Motor Mounting, Reversing	9982-373-002	1
2	Screw-Hex cap,3/8-16x1"	9545-029-005	4
3	Nut-Wizlock, 3/8-16	8640-415-004	4
4	Motor-Drive, Inverter	9376-307-003	1
*	Bushing-Motor mounting	9053-074-002	2
5	Rod-Motor Mounting	9497-222-008	1
6	Collar-s/Set Screws	9076-052-002	2
7	Pulley-Motor Drive	9453-169-012	1
*	Screw-Set, 5/16-18x1/2"	9545-028-013	2
8	Chain-Motor Tension	9099-012-008	1
9	Spring, Motor Tension	9534-319-002	1
10	Motor, Blower	9376-322-001	4
*	Run Capacitor, Motor	5191-108-002	1
*	Start Capacitor, Motor	5191-109-002	1
*	Screw HXCAP, 3/8-16x3/4 (Motor mounting to Plate)	9545-029-008	4
*	Lock-Washer, 3/8" (Motor mounting to Plate)	8641-582-003	4
11	Plate, Motor Blower	9982-352-002	1
*	Gasket, Motor Plate	9206-428-001	1
12	Nut-3/8-16, Plate to cabinet	8640-415-004	4
*	Impeller w/set screw	9278-037-003	1
*	Tolerance Ring	9487-234-001	1
13	Pulley, Driven	9908-043-002	1
14	Washer-Flat, 1/2	8641-581-026	1
15	Washer-Lock, Ext. tooth, 1/2	8641-582-016	1
16	Bolt-3/4, 1/2-13x1/14	9545-017-009	1
*	Support Arm, Intermediate pulley	9991-053-002	1
*	Bolt- 3/8-16x1 1/4	9545-029-010	3
*	Nut, Wizlock, 3/8x16	8640-415-004	3
*	Cap Screw, 3/8-16x1 1/2	9545-029-012	1
*	Snap Ring	9487-200-003	1
*	Washer-Flat, 3/8x1	8641-581-035	1
*	Idler Arm Assembly	9861-024-002	1
*	Snap Ring	9487-200-006	
*	Washer-Flat, 3/8x1	8641-581-039	1
17	Pulley, Idler w/Bearings	9908-042-006	1
*	Snapring, Inside-Bearing	9487-238-005	1
18	Bearing, Ball	9036-159-007	2
*	Spacer, Bearing	9538-173-002	1
19	Washer-Flat	8641-581-039	1
20	Nut, 5/8-11	8640-425-002	1
*	Hook "S" type	9248-022-002	3
*	Chain, Spring tension	9099-012-009	1
*	Spring, tension	9534-151-000	1
21	Belt Drive	9040-076-003	1
22	Belt, Driven	9040-073-012	1
23	Thermostat-Overtemp, Reset	9576-207-006	1

Dryer Rear View 80 Lb Reversing

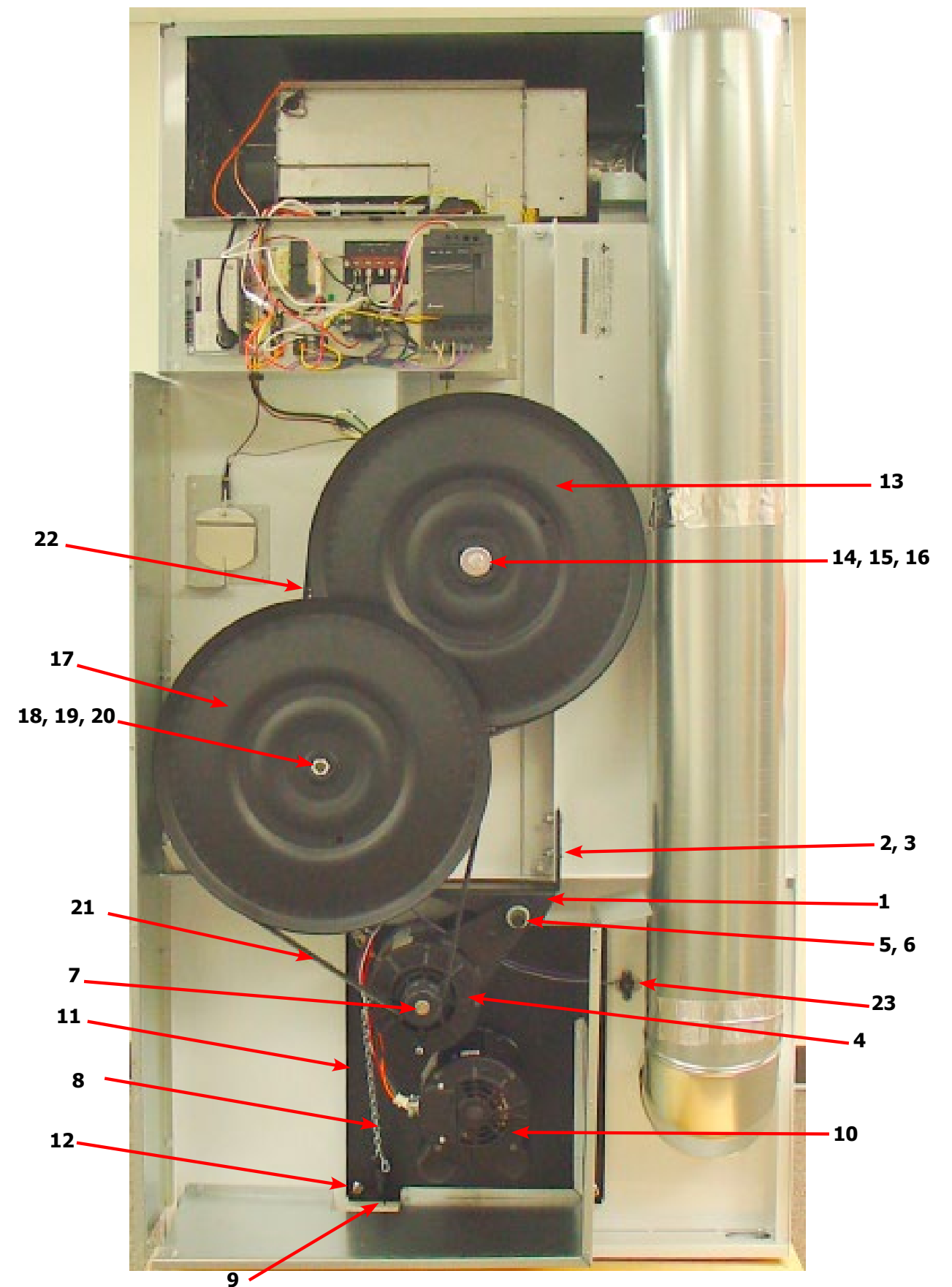

Dryer Rear View 80 Lb Reversing Continued

Key	Description	T-80	QTY
1	Plate-Motor Mounting, Reversing	9982-373-001	1
2	Screw-Hex cap,3/8-16x1"	9545-029-005	4
3	Nut-Wizlock, 3/8-16	8640-415-004	4
4	Motor-Drive, Inverter	9376-307-003	1
*	Bushing-Motor mounting	9053-074-002	2
5	Rod-Motor Mounting	9497-222-008	1
6	Collar-s/Set Screws	9076-052-002	2
7	Pulley-Motor Drive	9453-169-012	1
*	Screw-Set, 5/16-18x1/2"	9545-028-013	2
8	Chain-Motor Tension	9099-012-008	1
9	Spring, Motor Tension	9534-319-002	1
10	Motor, Blower	9376-322-001	1
*	Capacitor, Motor Run	5191-108-002	1
*	Capacitor, Motor Start	5191-109-002	1
*	Screw HXCAP, 3/8-16x3/4 (Motor mounting to Plate)	9545-029-008	4
*	Lock-Washer, 3/8" (Motor mounting to Plate)	8641-582-003	4
11	Plate, Motor mounting	9982-352-002	1
*	Gasket, Motor Plate	9206-428-002	1
12	Nut-3/8-16, Plate to cabinet	8640-415-004	4
*	Impeller w/set screw	9278-037-003	1
13	Support Arm, Intermediate pulley	9991-053-002	1
14	Bolt- 3/8-16x1 1/4	9545-029-010	3
15	Nut, Wizlock, 3/8x16	8640-415-004	3
16	Cap Screw, 3/8-16x1 1/2	9545-029-012	1
*	Snap Ring	9487-200-003	1
*	Washer-Flat, 3/8x1	8641-581-035	1
17	Idler Arm Assembly	9861-024-002	1
*	Snap Ring	9487-200-006	1
*	Washer-Flat, 3/8x1	8641-581-039	1
18	Hook "S" type	9248-022-002	3
19	Chain, Spring tension	9099-012-002	1

Dryer Rear View 80 Lb Reversing Continued

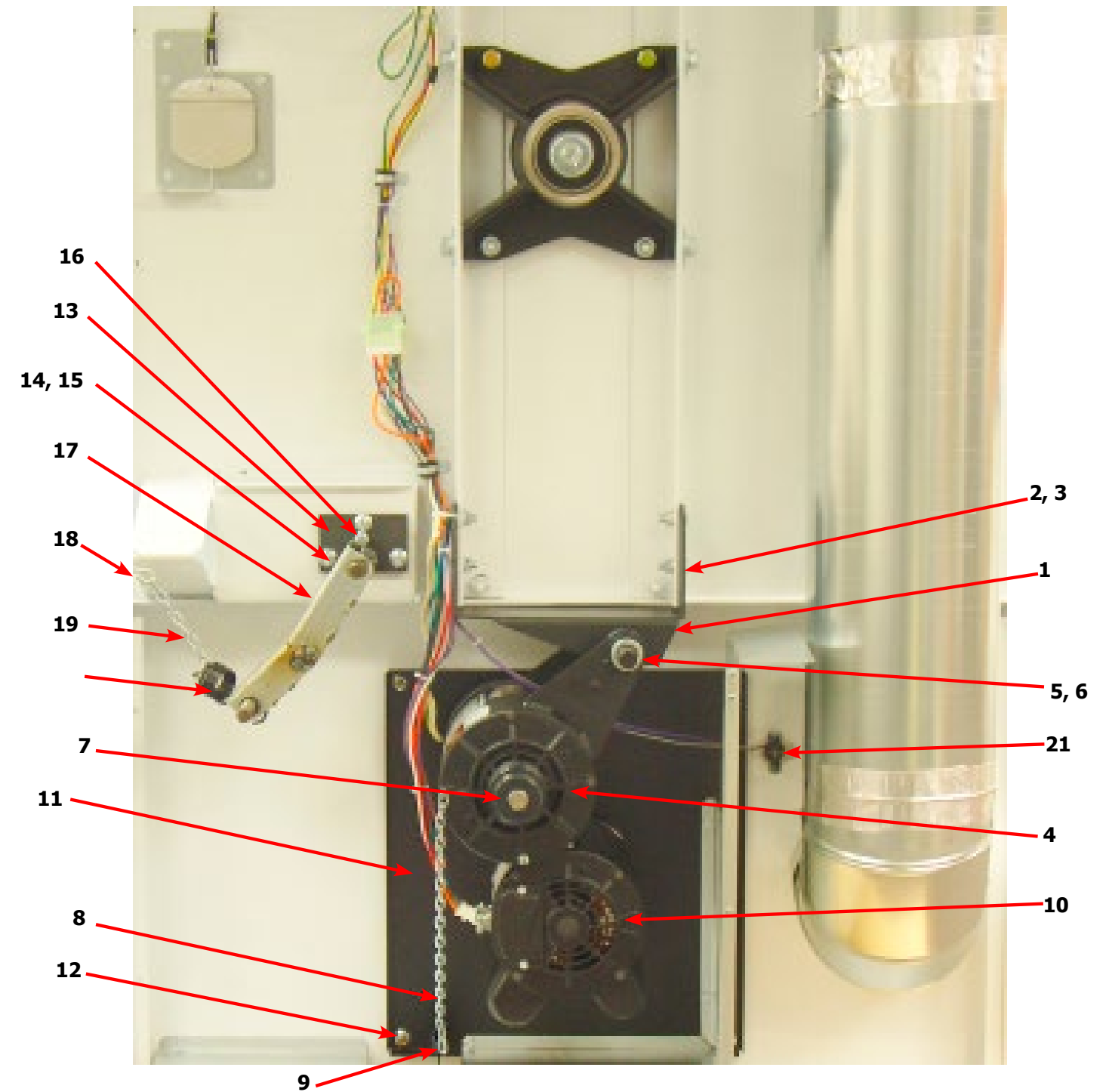

Dryer Rear View-Guard & Exhaust

Key	Description	T80	QTY
1	Cover Cabinet	9074-349-001	1
*	Screw-5/16, 10ABx3/8	9545-008-024	AR
2	Cover-Control Box	9074-353-001	1
3	Screw-5/16, 10ABx3/8	9545-008-024	AR
4	Guard, RH	9208-101-001	1
*	Screw-5/16, 10ABx3/8	9545-008-024	AR
5	Guard Base & LH	9208-102-001	1
*	Screw-5/16, 10ABx3/8	9545-008-024	AR
6	Guard-Lower	9208-103-001	1
7	Screw-5/16, 10ABx3/8	9545-008-024	AR
8	Guard-upper	9208-105-001	1
*	Screw-5/16, 10ABx3/8	9545-008-024	AR
9	Elbow-90 degree, 8"	9142-039-001	1
10	Pipe-Duct, 8"	9109-121-002	1
11	Tee-Duct, Recirculation, 8"-6"	9810-019-001	1
12	Damper	9125-008-001	1
*	Pin-Damper, Hinge	9451-146-002	1
*	Nut-Spring	8520-141-000	2
13	Bracket-Recirculation Duct, Small	9029-228-001	1
14	Pipe-Duct, 6"	9109-122-003	1
15	Bracket-Duct, Recirculation Large	9029-247-001	1
16	Elbow-90 degree, 6"	9142-039-002	1
*	Booklet-Owners	8514-210-001	1
17	Diagram & Schematics	9506-476-001	1
18	Label-Warning & Notice	8502-600-001	1
19	Label-Instructions	8502-645-001	1
20	Decal-Lighting & Clearance	8527-151-001	1
21	Label-High Voltage	8502-614-004	1
*	8" Slide Open Clean Out Duct (Optional)	9973-034-001	1

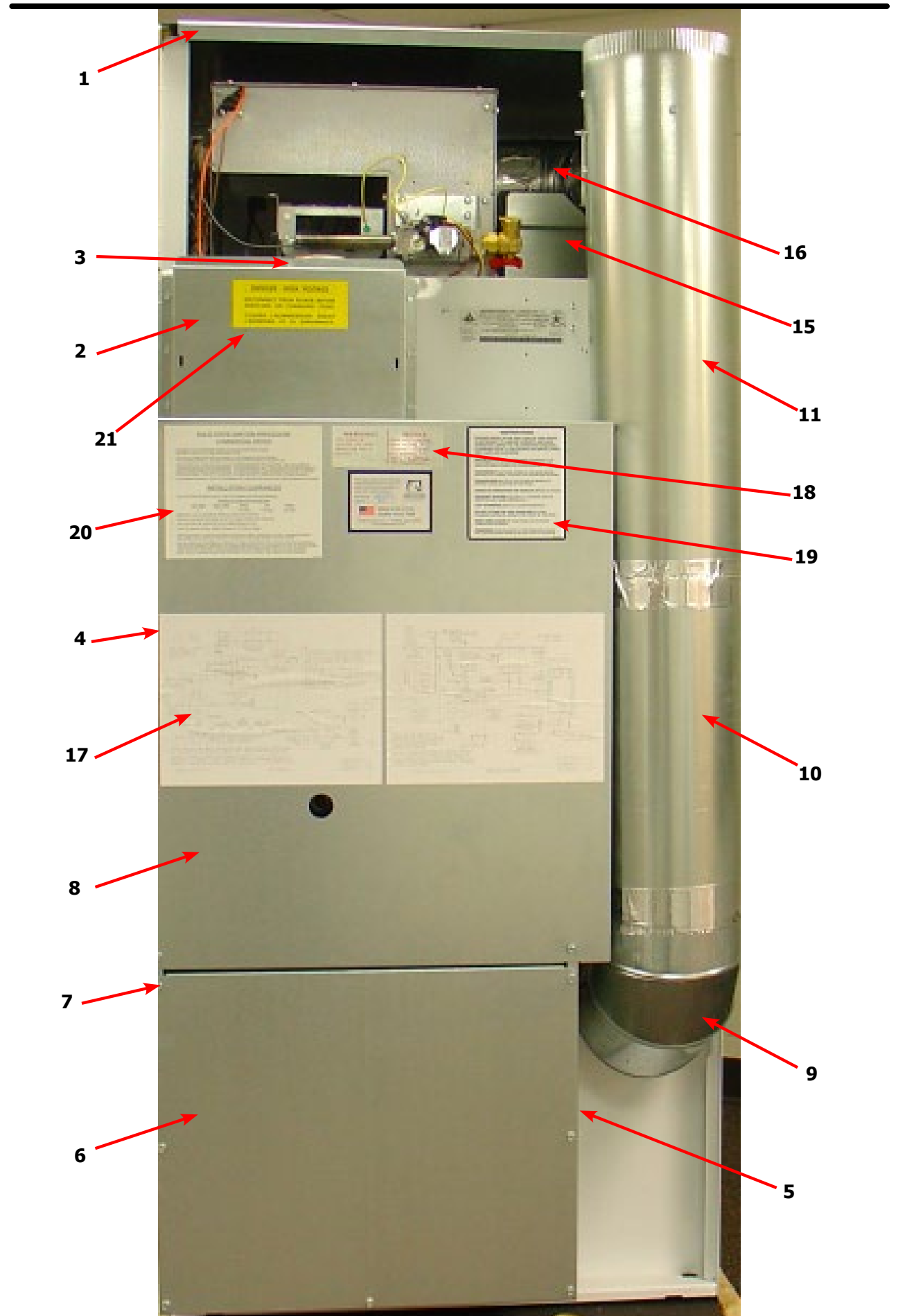
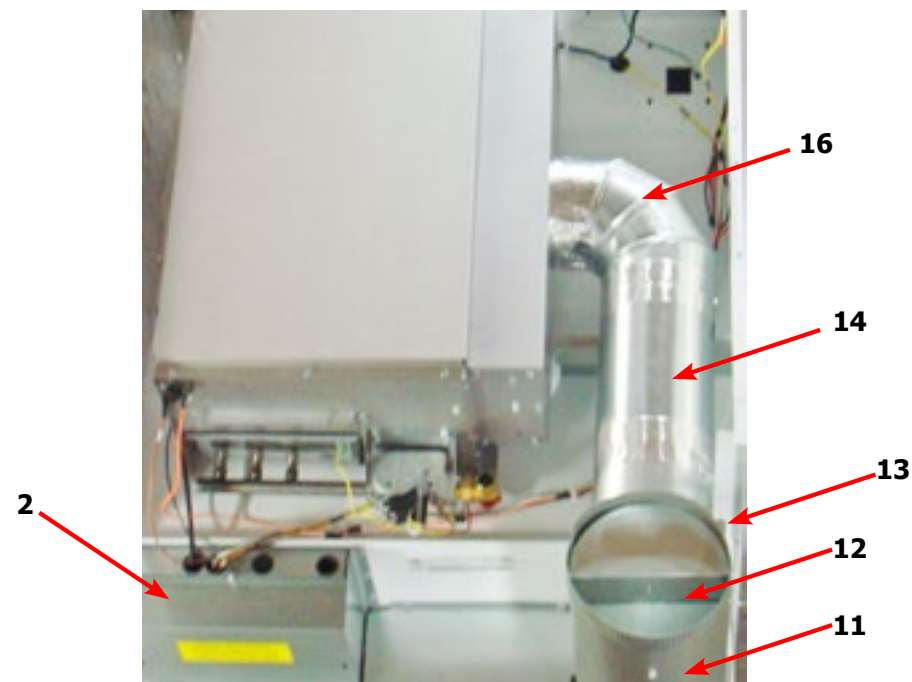

Dryer Rear View-Bearing Housing 80Lb

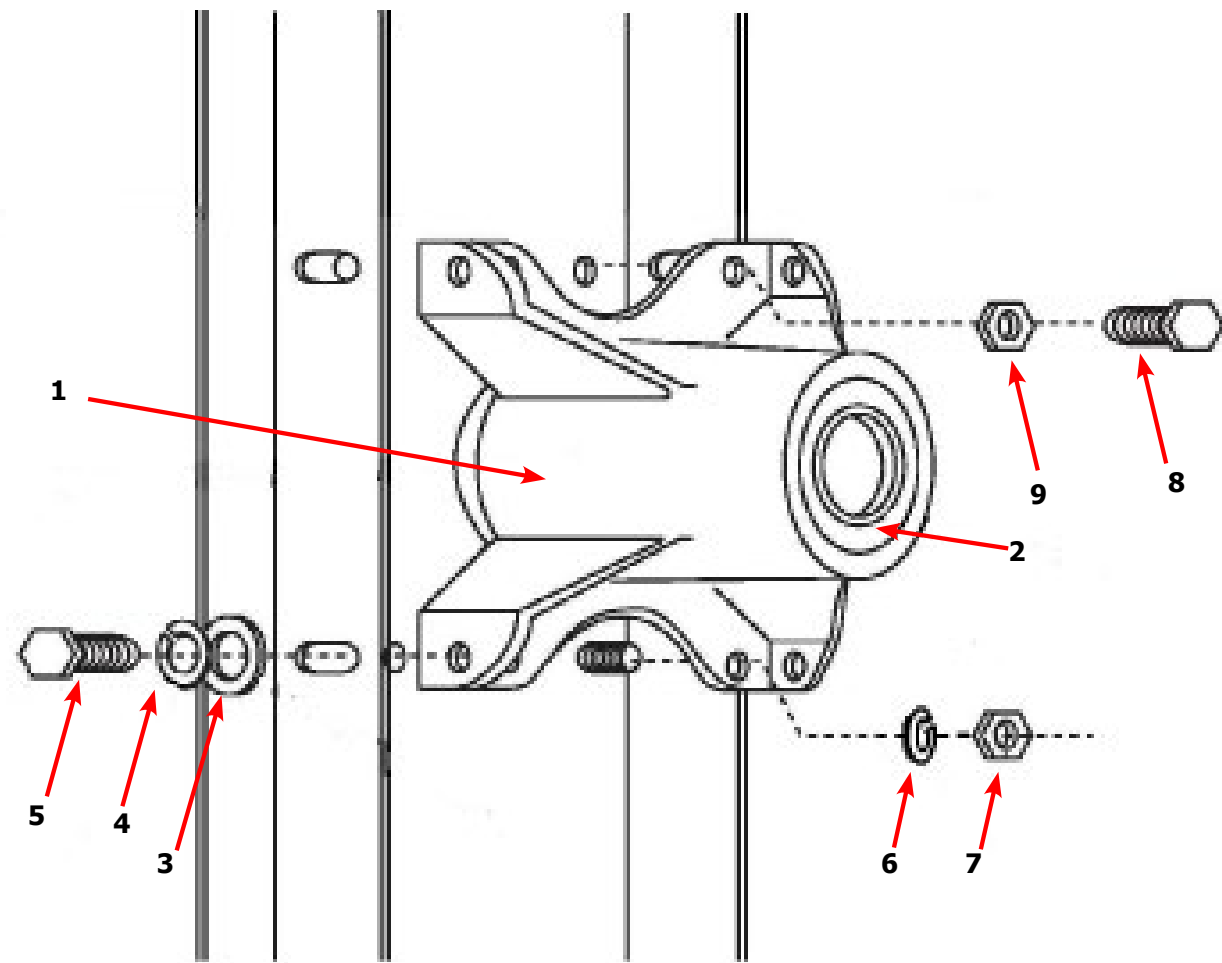

Key	Description	T-80	QTY
	Bearing Housing Complete Assy (Includes bearings & Spacer)	9803-189-001	
1	Housing, Bearing	9241-183-003	
*	Bearing, Ball, Front	9036-159-002	
2	Bearing, Ball, Rear	9036-159-001	
3	Washer, Flat 1/2	8641-581-026	
4	Lock Washer Spring, 1/2	8641-582-004	
5	Screw, 1/2-13x1	9545-017-004	
6	Lock Washer Spring, 1/2	8641-582-004	
7	Nut, 7/16-14	8640-416-001	
8	Screw, 7/16-14x1 1/2	9545-059-003	
9	Nut, 7/16-14	8641-416-001	

Dryer Tumbler Group 80Lb

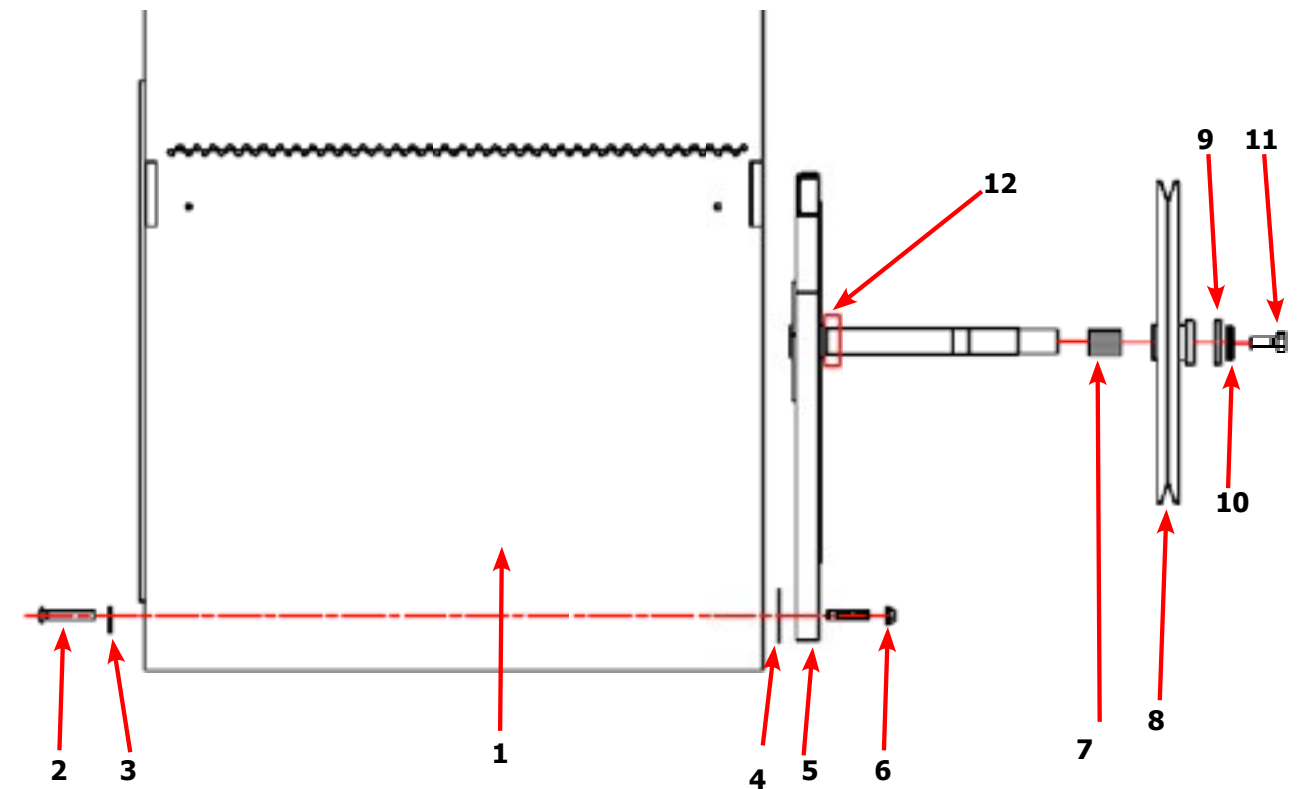

Key	Description	T80	QTY
*	Tumbler Assy Complete W/Spider (GALV)	9848-139-001	1
1	Tumbler Assy (Galvanized)	9849-138-001	1
1	Tumbler Assy Complete W/Spider (SS & Galv front)	9848-139-002	1
1	Tumbler Assy (Stainless Galvanized front)	9849-138-002	1
2	Rod, Tumbler	9497-226-001	4
3	Washer, Special	8641-590-001	4
4	Shim	9552-013-003	AR
5	Spider Assy w/Front Bearing	9873-008-001	1
6	Nut, Wiz Lock	8640-417-005	4
7	Tolerance Ring	9487-234-001	1
8	Pulley, Driven	9908-043-002	1
9	Washer -Flat	8641-581-026	1
10	LockWasher - IntTooth, 1"	8641-582-016	1
11	Screw, 1/2-13x1 1/4	9545-017-009	1
12	Bearing, Front	9036-159-002	1

Dryer Burner Housing Group 80Lb

Key	Description	Part Number	Qty
	Housing Assembly, Burner	9803-212-001	1
1	Panel-Burner Housing, Front	9454-863-001	1
2	Panel-Burner Housing, Side Right	9454-861-001	1
3	Panel-Burner Housing, Side Left	9454-862-001	1
4	Panel-Burner Housing, Back	9454-864-001	1
5	Baffle-Burner Housing, Center	9049-098-001	1
6	Panel-Burner Housing, Top	9454-849-001	1
7	Panel-Burner Housing, Top	9074-343-001	1
8	Baffle-Burner Housing, Extention	9049-100-001	1
9	Duct Adaptor, 6"x1.25" long	9109-120-002	1
10	Baffle-Burner Housing, Recirculation	9049-099-001	1
11	Side-Extention Baffle, Burner Housing	9551-049-001	2
12	Bracket-Support, Burner	9029-213-001	1
13	Burner, Main	9048-021-001	4
14	Screw, 10T-32x1/2	9545-008-008	4
15	Electrode-Ignition	9875-002-003	1
16	Cover-Burner, Intet	9074-344-001	1
17	Bracket-Support, Gas Valve	9029-234-001	1
18	Control Assy, Gas Valve, White Rodgers 36J	9857-193-001	1
19	Bracket-support, Gas Valve Left hand	9029-235-001	4
20	Valve-Gas Shutoff, (Optional)	9379-196-001	1
21	Manifold Assy	9381-014-001	1
22	Orifice-Natural, #29	9425-069-021	4
*	Orifice-LP, #46	9425-069-022	4
*	Kit, LP Conversion, White Rodgers	9732-102-023	1
23	Thermostat-HI-Limit	9576-203-002	1
24	Spacer-1/4x5/8 long	9538-166-009	2
25	Screw-8Bx1	9545-045-013	2
26	Screw, 10Bx1/4	9545-008-001	22
27	Screw, 10ABx3/8	9545-008-024	31
28	Bushing-Reducer, 3/4x1/2	8615-104-009	1

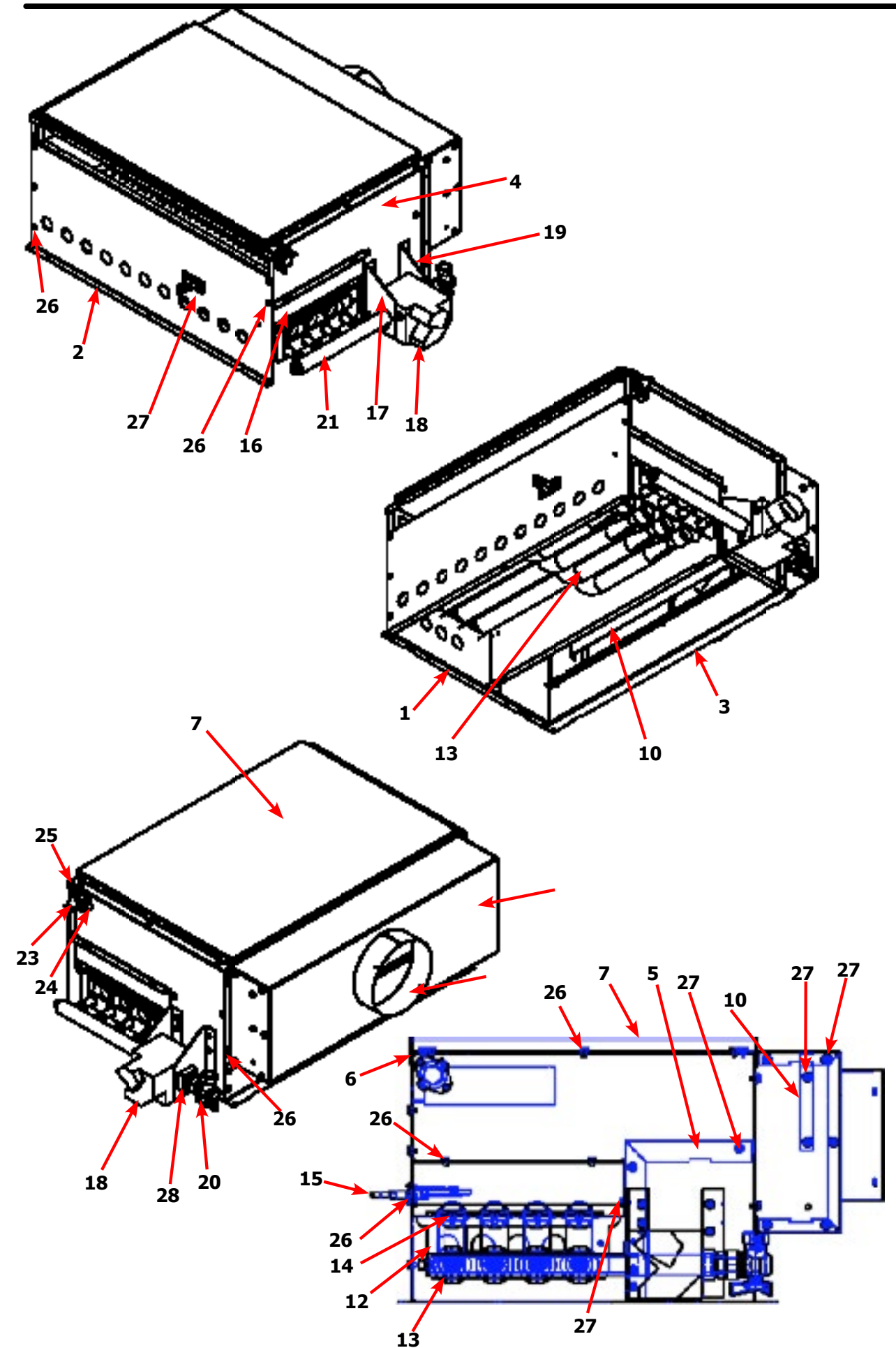

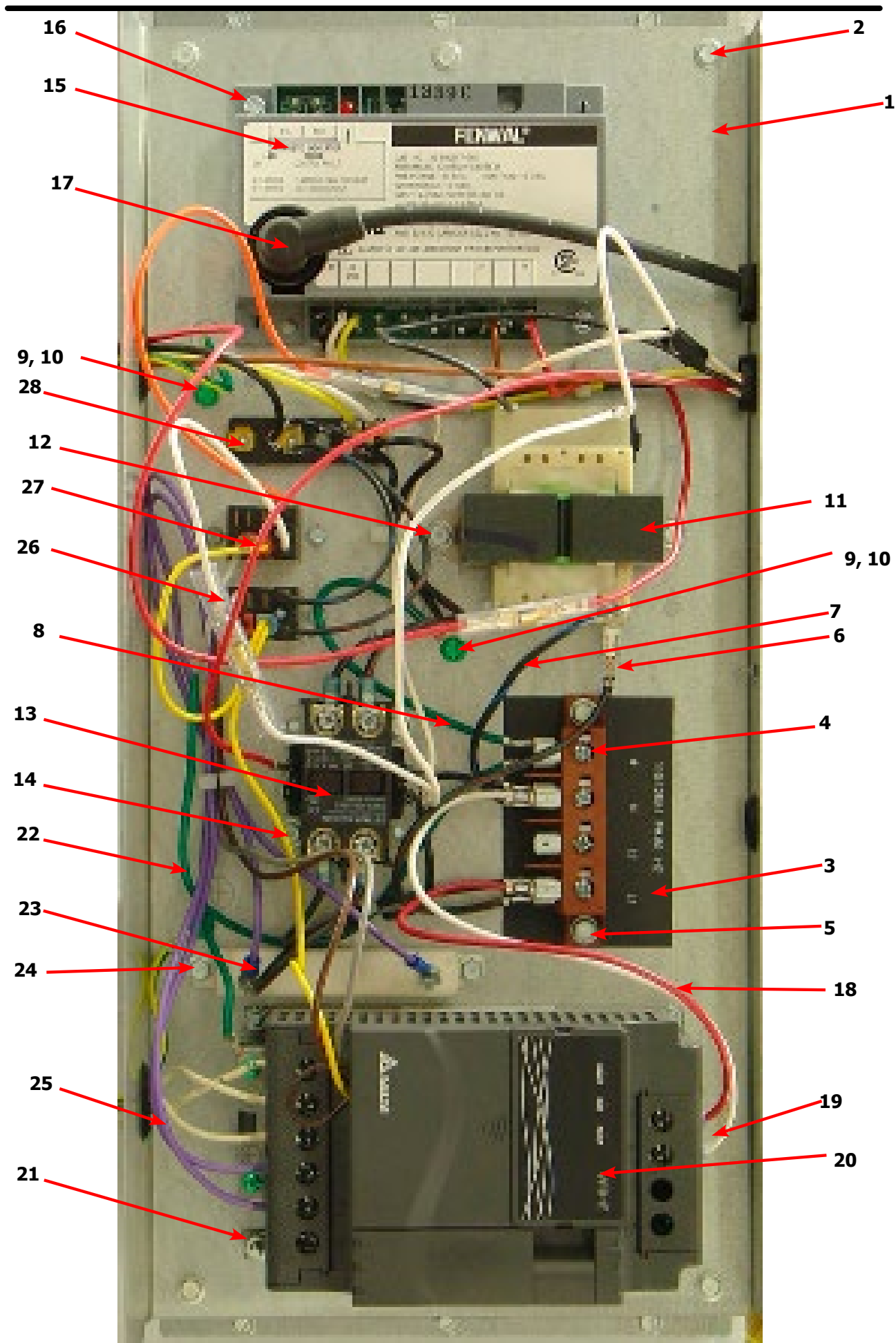

Dryer Rear View-Control Box

Key	Description	T80	QTY
1	Wrapper-Control Box	9636-203-001	1
2	Screw, 5/16-10AB-3/8	9545-008-001	6
*	Cover-Control Box	9074-353-001	1
*	Screw, 5/16-10AB-3/8	9545-008-024	1
3	Strip-Marker, Terminal	9558-029-005	1
4	Terminal Block Assy-Power, 4Pole	9897-035-001	1
5	Screw, 5/16-10AB-3/8	9545-008-024	2
6	Wire assy-Blk/Red, 6 1/2"	8220-001-230	1
7	Wire assy-Blk/Blu, 6 1/2"	8220-001-231	1
8	Wire Assy, GRN, 7"	8220-001-478	1
9	Screw- 10-32TTx1/2 GRN	9545-008-027	2
10	Lockwasher, External tooth	8641-582-006	2
11	Transformer, w/Circuit braker	8711-007-002	1
12	Screw, 5/16-10AB-3/8	9545-008-024	2
13	Relay-Motor, 30Amp, 24VAC	5192-299-002	1
14	Screw, 5/16-10AB-3/8	9545-008-024	2
*	Wire assy-Blk/Red, 9"	8220-146-001	2
*	Wire assy-Blk/Blu, 9"	8220-146-002	2
15	Control Assy, Ignition (Module)	9857-182-001	1
16	Screw-8Bx3/4"	9545-045-007	2
*	Harness, Ignition Module	9627-867-003	1
17	Wire Assy- High Voltage Lead	9631-403-009	1
18	Wire Assy-Red, 12"	8220-067-004	1
19	Wire Assy- White, 12"	8220-067-003	1
20	Drive-VD Inverter, 1HP, 120VAC	9375-026-002	1
21	Nut, #10-32UNF	8640-413-002	4
22	Wire Assy-Green, 18"	8220-092-006	1
*	Wire Assy-BRN, 19"	8220-078-019	1
*	Wire Assy-Yellow, 20"	8220-082-002	1
*	Wire Assy-Gray, 18"	8220-078-018	1
*	Wire Assy, Brown 3"	8220-057-035	1
23	Resistor-Dynamic Breaking, 200OHM	9483-004-002	1
24	Screw-5/16, 10ABx3/8	9545-008-024	2
25	Wire Assy, Violet 24"	8220-118-001	2
26	Relay, 120VAC	5192-285-001	1
27	Relay, 24VAC	5192-285-004	1
*	Wire Assy-BLK/BLU, 15"	8220-063-021	1
*	Wire Assy-BLK/RED, 12"	8220-063-010	1
28	Terminal Block	9897-039-001	1

Wiring Informative for 60hz Dryer -10BD

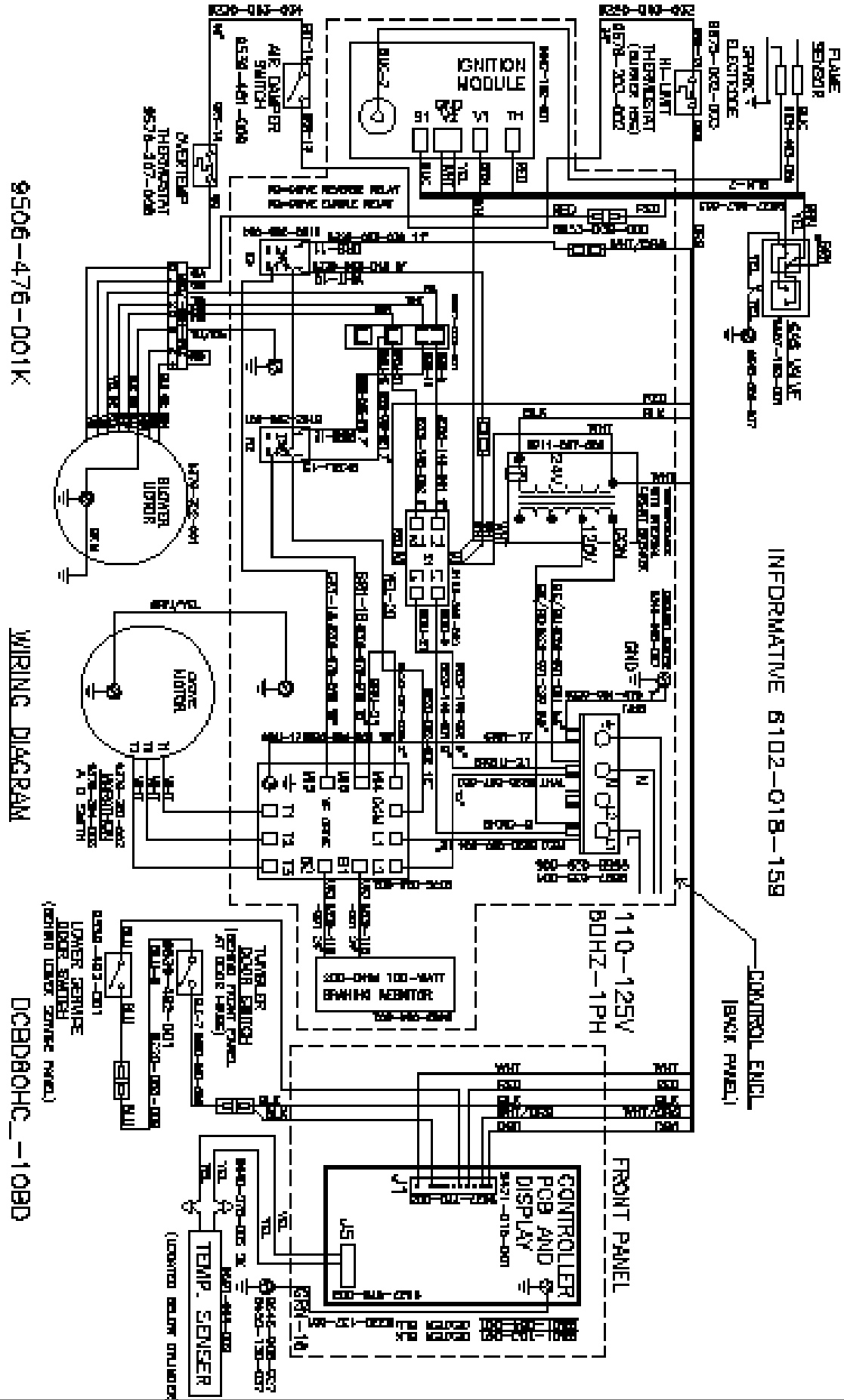

9506-476-001K

WIRING DIAGRAM

DC8D80HC-10BD

Control Box Informative for 60hz Dryer -10BD

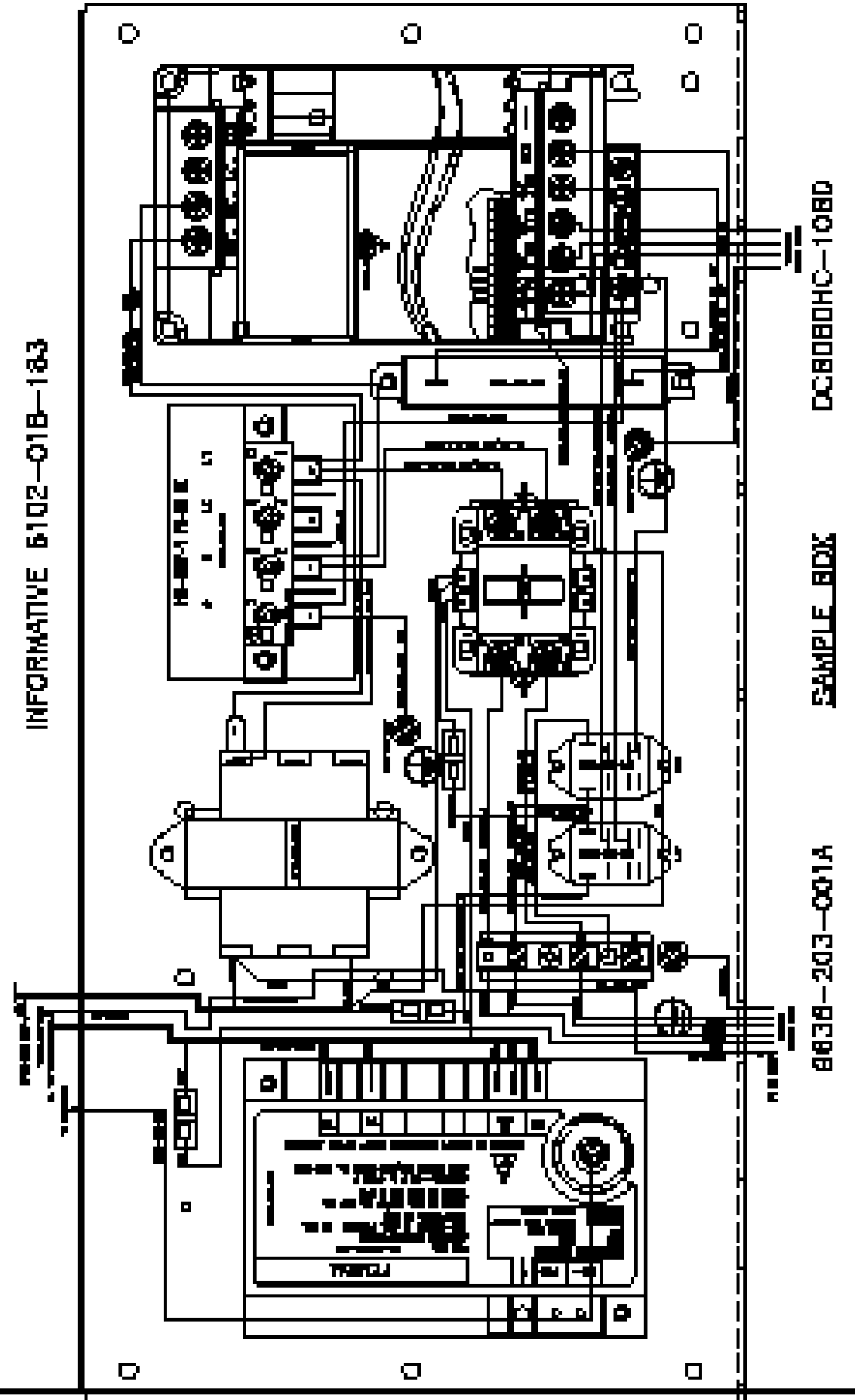

DC8D80HC-10BD

SAMPLE_BDX

6836-203-001A

Wiring Schematic for 60hz Dryer -10BD

CAUTION: LABEL ALL WIRES PRIOR TO DISCONNECTION WHEN SERVICING CONTROLS. WIRING ERRORS CAN CAUSE IMPROPER AND DANGEROUS OPERATION. VERIFY PROPER OPERATION AFTER SERVICING.

ATTENTION: AU MOMENT DE L'ENTRÉE DES COMMANDES, ÉTIQUÉTES TOUTES LES FILS AVANT DE LES DÉBRANCHER. DES ERREURS DE CHANGEMENT PEUVENT ENTRÂNER UN FONCTIONNEMENT IMPROPRE ET DANGEREUX. S'ASSURER QUE L'APPAREIL FONCTIONNE ADÉQUATEMENT UNE FOIS L'ENTRÉE EN SERVICE.

- NOTES:
1. DOOR SWITCHES-UP, CLOSED WHEN DOORS ARE CLOSED.
 2. DRYER STARTS WHEN THE MOTORS ARE CLOSED. A CIRCLE IS SELECTED AND THE START BUTTON IS PUSHED. THERE IS AN AUTOMATIC COOL DOWN CYCLE AT THE END OF THE CYCLE.
 3. CENTRIFUGAL SWITCH-NO, CLOSURES WHEN BLOWER MOTOR IS UP TO SPEED.
 4. REFER TO OWNER'S MANUAL FOR DESCRIPTION OF OPERATION AND REQUIREMENTS FOR HEATING CIRCUIT.
 5. WITH A DC MICROAMMETER, FLAME CURRENT CAN BE MEASURED AT TEST POINTS. READING SHOULD BE 0.7uA DC OR HIGHER.

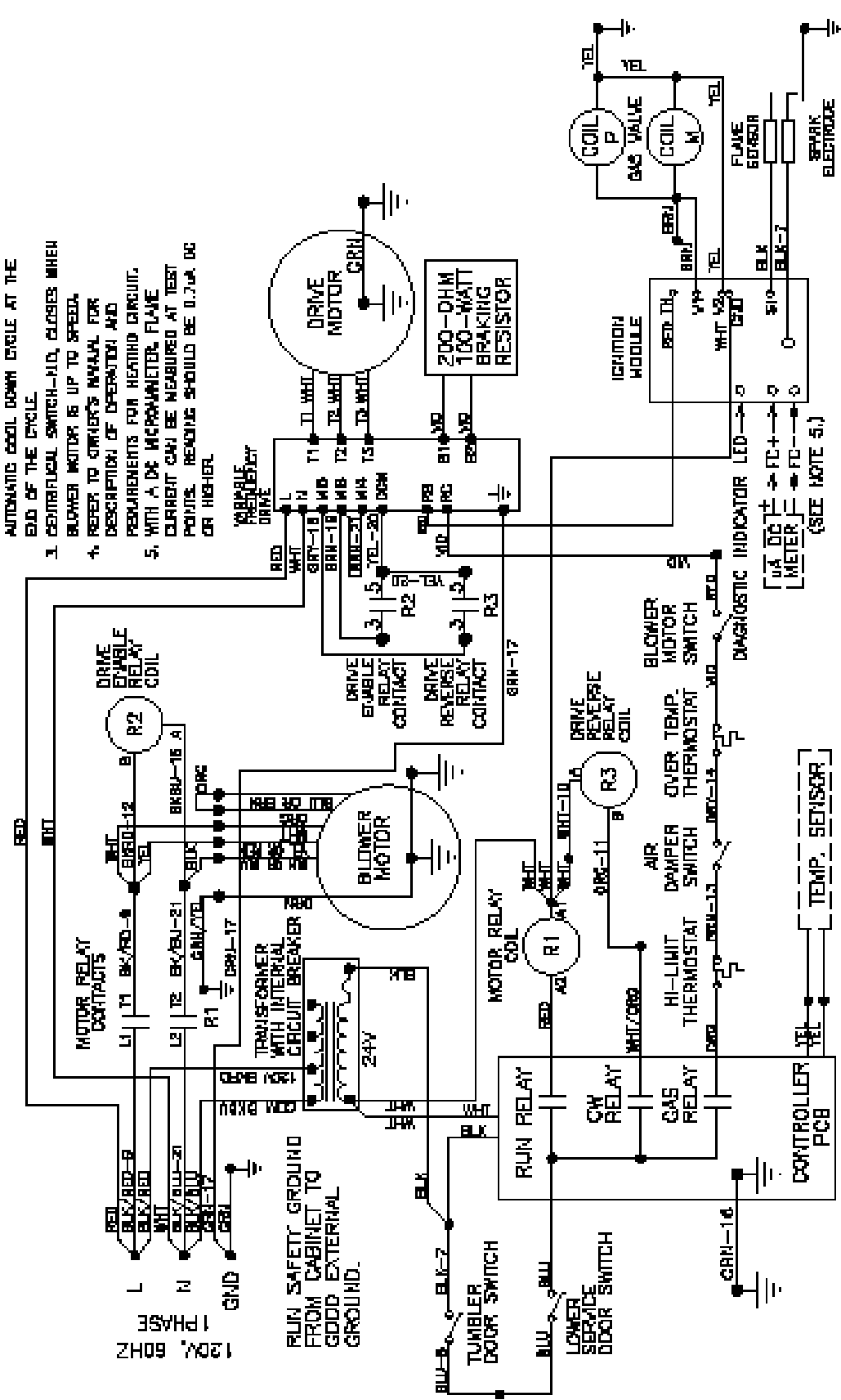

9506-476-001M SCHEMATIC DCBDB0HC-10BD DND080N-10_B_R-X

Wiring Diagram for 60hz Dryer -10BD

CAUTION: LABEL ALL WIRES PRIOR TO DISCONNECTION WHEN SERVICING CONTROLS. WIRING ERRORS CAN CAUSE IMPROPER AND DANGEROUS OPERATION. VERIFY PROPER OPERATION AFTER SERVICING.

ATTENTION: AU MOMENT DE L'ENTRÉE DES COMMANDES, ÉTIQUÉTES TOUTES LES FILS AVANT DE LES DÉBRANCHER. DES ERREURS DE CHANGEMENT PEUVENT ENTRÂNER UN FONCTIONNEMENT IMPROPRE ET DANGEREUX. S'ASSURER QUE L'APPAREIL FONCTIONNE ADÉQUATEMENT UNE FOIS L'ENTRÉE EN SERVICE.

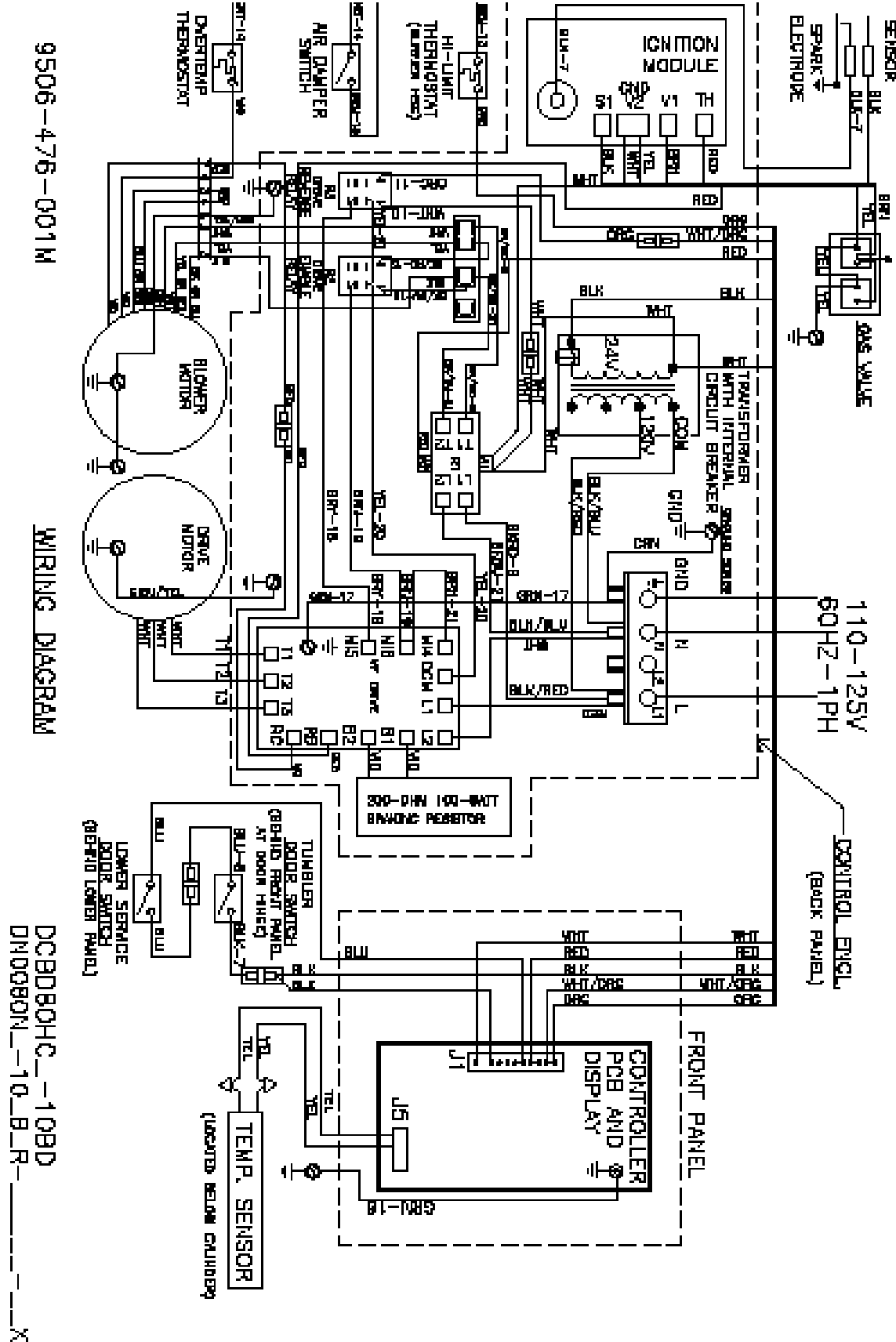

9506-476-001M WIRING DIAGRAM DCBDB0HC-10BD DND080N-10_B_R-X

Key	Description	T80	QTY
*	Motor-Drive	9376-307-003	1
*	Pulley	9453-169-012	1
*	Motor-Blower	9376-325-001	1
*	Wiring Label-Schematic/Diagram	9506-497-001	1
*	Orifice Main Burner, #30	9425-069-002	4
*	Overlay-Trim Lower door	9435-016-006	1
*	Label- Warning instructions	8502-698-001	1

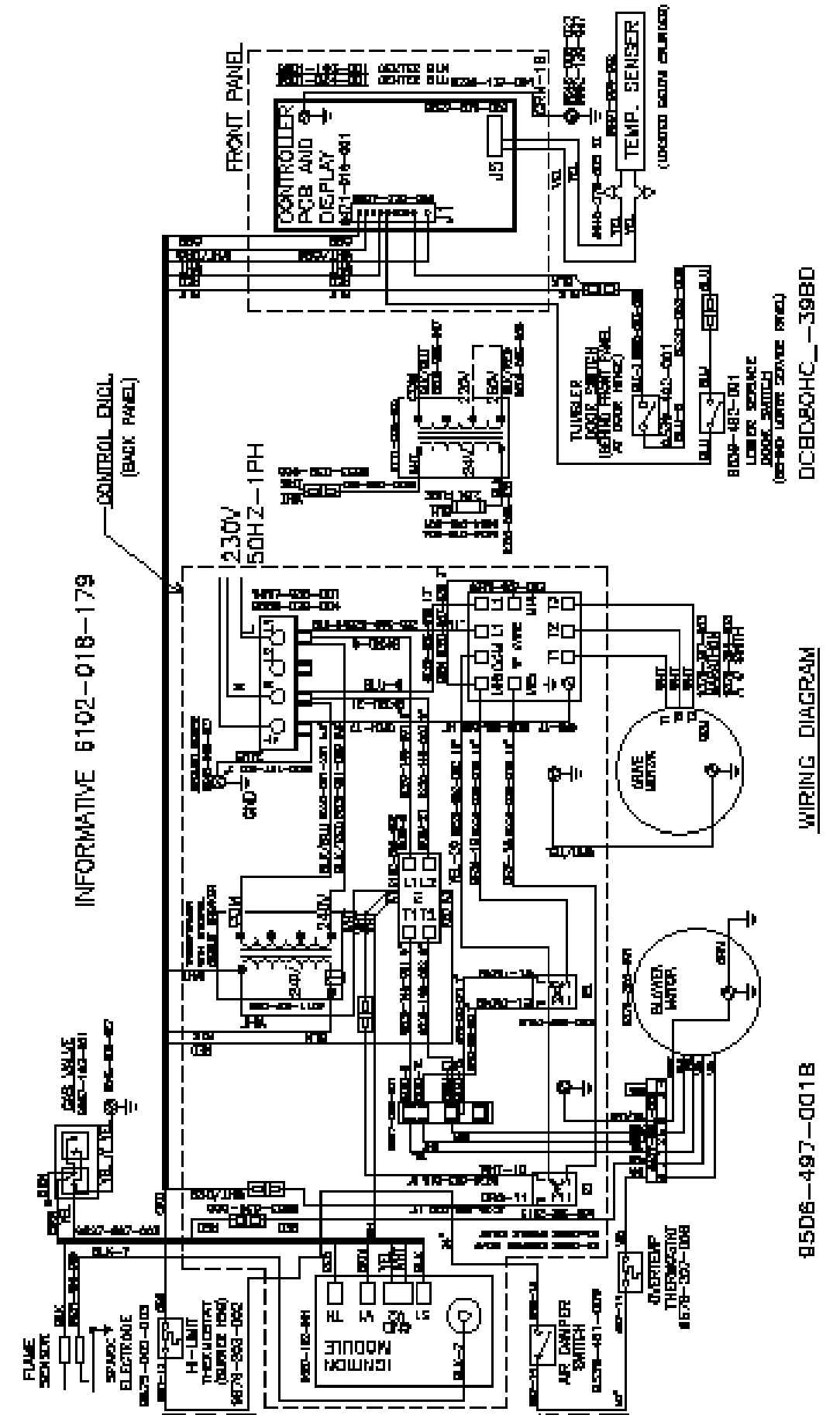

Key	Description	T80	QTY
*	Wrapper-Control Box	9636-203-001	1
*	Screw, 5/16-10AB-3/8	9545-008-024	9
*	Cover-Control Box	9074-353-001	1
*	Screw, 5/16-10AB-3/8	9545-008-024	1
*	Strip-Marker, Terminal	9558-029-004	1
*	Terminal Block Assy-Power, 4Pole	9897-035-001	1
*	Screw, 5/16-10AB-3/8	9545-008-024	2
*	Wire assy-Blk/Red, 6 1/2"	8220-001-230	1
*	Wire assy-Blk/Blu, 6 1/2"	8220-001-231	1
*	Wire Assy, GRN/Yel, 7"	8220-137-002	1
*	Screw- 10-32TTx1/2 GRN	9545-008-027	2
*	Lockwasher, External tooth	8641-582-006	2
*	Transformer, w/Circuit braker	8711-007-002	1
*	Screw, 5/16-10AB-3/8	9545-008-024	2
*	Relay-Motor, 30Amp, 24VAC	5192-299-002	1
*	Screw, 5/16-10AB-3/8	9545-008-024	2
*	Wire assy-Blk/Red, 9"	8220-146-001	2
*	Wire assy-Blk/Blu, 9"	8220-146-002	2
*	Control Assy, Ignition (Module)	9857-182-001	1
*	Screw-8x3/4"	9545-045-007	2
*	Harness, Ignition Module	9627-867-003	1
*	Wire Assy- High Voltage Lead	9631-403-009	1
*	Wire Assy-Blue, 17"	8220-065-018	1
*	Wire Assy- Black, 11"	8220-065-032	1
*	Drive-VD Inverter, 1HP, 120VAC	9375-027-002	1
*	Nut, #10-32UNF	8640-413-002	4
*	Wire Assy-Green, 18"	8220-092-006	1
*	Wire Assy-BRN, 19"	8220-078-019	1
*	Wire Assy-Yellow, 20"	8220-082-002	1
*	Wire Assy-Gray, 18"	8220-078-018	1
*	Wire Assy, Brown 3"	8220-057-035	1
*	Relay, 230VAC	5192-285-002	1
*	Relay, 24VAC	5192-285-004	1
*	Wire Assy-BLK/BLU, 15"	8220-063-021	1
*	Wire Assy-BLK/RED, 12"	8220-063-010	1

