



DEXTER[®]
LAUNDRY

**USE THE BLUE TABS LOCATED ON THE
RIGHT AND LEFT SIDES OF THE FOLLOWING
DOCUMENT TO ADVANCE TO EACH SECTION.**

Kits, Assemblies, & Common Parts

DC0030__-10
DC0050__-10
DC0080__-10

Description	T-30	T-50	T-80
Optical Coin Switch	9801-099-002	9801-099-002	9801-099-002
Kit - T80 Bottom exhaust			9732-348-001
Kit - 9873-008-001 w/ bearings & tolerance ring			9732-329-001
Kit - A to C series Conversion, Black, 120v	9732-307-002	9732-307-002	9732-307-002
Kit - A to C series Conversion, Blue, 120v	9732-307-001	9732-307-001	9732-307-001
LP to Natural Conversion Kit for White Rodgers	9732-142-004	9732-142-004	9732-142-004
Coin Acceptor switch kit w/ extra actuator	9732-126-001	9732-126-001	9732-126-001
Kit, Optional Replacement for Round Switch 9539-492-001	9732-351-001	9732-351-001	9732-351-001
Temperature Probe	9501-004-002	9501-004-002	9501-004-002
Controls	9471-022-001	9471-022-001	9471-022-001
Coin Drop	9021-093-001	9021-093-001	9021-093-001
Coin Drop Screws	9545-053-002	9545-053-002	9545-053-002
Ignition Control Box	9857-182-001	9857-182-001	9857-182-001
Electrode Assembly, Ignition	9875-002-003	9875-002-003	9875-002-003
Thermostat, Hi-Limit	9576-203-002	9576-203-002	9576-203-002
Thermostat, Overtemp	9576-207-006	9576-207-006	9576-207-006
Motor Run Relay	5192-299-002	5192-299-002	5192-299-002
Transformer, Ignition	8711-007-002	8711-007-002	8711-007-002
Lint Screen Assembly	9822-026-002	9822-026-001	9822-031-002
Air Flow Switch	9029-174-001	9029-200-001	9029-200-001
Switch-Door Closure (Square)	9539-501-001	9539-501-001	9539-501-001
Switch-Door Closure (Round)	9539-492-001	9539-492-001	9539-492-001
Motor Belt	9040-076-003	9040-076-006	9040-076-011
Tumbler Belt	9040-073-009	9040-073-011	9040-073-012
Tension Arm Complete	9861-002-001	9861-002-002	9861-024-004
Spider/Trunnion	9568-015-001	9568-013-001	9873-008-001
Door Handle	9244-082-001	9244-082-001	9244-082-001
Run Capacitor		5191-108-001	5191-108-001
Start Capacitor		5191-109-001	5191-109-001
Cleanout Duct Assembly 8"	9973-034-001	9973-034-001	9973-034-001



Section 5: Dryer Parts Data

DC0030__-10
DC0050__-10
DC0080__-10

Starting Serial Number D1.15224.001

Key	Description	T-30	T-50	T-80	QTY
1	Loading Door Complete SS/Brushed SS/Blk	9960-306-001	9960-305-001	9960-305-001	1
1	Loading Door Complete Wht/Brushed SS/Blk	9960-306-003	9960-305-003	9960-305-003	1
2	Door Assy, Loading (Ring only) Brushed SS	9960-255-008	9960-284-002	9960-284-002	1
3	Plate Assy, Hinge (SS)	9982-374-001	9982-368-001	9982-368-001	1
3	Plate Assy, Hinge (Wht)	9982-374-003	9982-368-003	9982-368-003	1
*	Cover-Hinge Back, Black	9074-341-002	9074-340-002	9074-340-002	1
*	Screw-10Bx3/8, Black	9545-008-010	9545-008-010	9545-008-010	2
*	Screw Hinge to Door	9545-012-015	9545-012-015	9545-012-015	4
*	Nut, Hinge to Door	8640-413-002	8640-413-002	8640-413-002	4
4	Glass, Door	9212-002-003	9212-002-004	9212-002-004	1
5	Gasket, Door Glass (Black)	9206-413-001	9206-413-002	9206-413-002	1
*	Support Door Glass	9548-117-000	9548-117-000	9548-117-000	2
6	Gasket, Door Outer Rim (Black)	9206-420-003	9206-420-005	9206-420-005	1
7	Handle, Loading Door	9244-082-001	9244-082-001	9244-082-001	1
*	Screw, Handle	9545-018-017	9545-018-017	9545-018-017	2
8	Stud Door Catch	9531-033-001	9531-033-002	9531-033-002	1
9	Nut-Hex, #10-32	8640-413-001	8640-413-001	8640-413-001	1
10	Nut, Acorn	8640-413-003	8640-413-003	8640-413-003	1
*	Catch, Loading Door	9086-015-002	9086-015-002	9086-015-002	2
*	Rivit	8638-190-009	8638-190-009	8638-190-009	4
11	Strap, Hinge (Black)	9966-018-002	9966-014-002	9966-014-002	1
*	Plate Assy-Backup, Hinge	9982-371-001	9982-356-001		1
*	Plate Assy-Backup, Hinge	9982-368-001		9982-369-001	1
*	Reinforcement-Front panel			9817-003-001	1
12	Screw-Phillips, 10-32x1/2 Chrome	9545-012-003	9545-012-003	9545-012-003	4
*	Screw-Phillips-Counter sink, 10-32x1/2 Chrome	NA	9545-012-028	9545-012-028	4
13	Screw-Special, Hinge to Door	9545-052-001	9545-052-001	9545-052-001	1
*	Nut-Allen, 1/4-20	8640-439-001	8640-439-001	8640-439-001	1
14	Washer-Fiber/Plastic	8641-436-003	8641-436-003	8641-436-003	1
15	Front Panel Assy (SS) Round Switch	9454-917-001	9454-865-001	9454-867-001	1
15	Front Panel Assy (SS) Square Swtich	9444-001-001	9444-003-001	9444-005-001	1
15	Front Panel Assy (Wht) Round Switch	9454-917-003	9454-865-003	9454-867-003	1
15	Front Panel Assy (Wht) Square Switch	9444-001-003	9444-003-003	9444-005-003	1
16	Screw-Phillips, 10Bx1 3/4	9545-008-014	9545-008-014	9545-008-014	4
17	Washer-Finish	8641-585-001	8641-585-001	8641-585-001	4
*	Nut-Spring (Before Serial)	8640-399-001	8640-399-001	8640-399-001	4
*	Nut, Expansion (After Serial D1.21187.042)	8640-442-001			4
*	Nut, Expansion (After Serial D1.21162.038)		8640-442-001		4
*	Nut, Expansion (After D1.21177.005)			8640-442-001	4
*	Insulation-Front Panel, Top Half	9277-063-001	9277-057-001	9277-058-001	1
*	Insulation-Front Panel, Bottom Half	9277-063-002	9277-057-001	9278-058-002	1
*	Switch-Door Closed (Square)	9539-501-001	9539-501-001	9539-501-001	1
*	Switch-Door Closed (Round)	9539-492-001	9539-492-001	9539-492-001	1
*	Wire-Assy, Blk	8220-063-026	8220-063-026	8220-063-026	1
*	Wire-Assy-Blu	8220-063-009	8220-063-009	8220-063-009	1

Dryer Cabinet Group

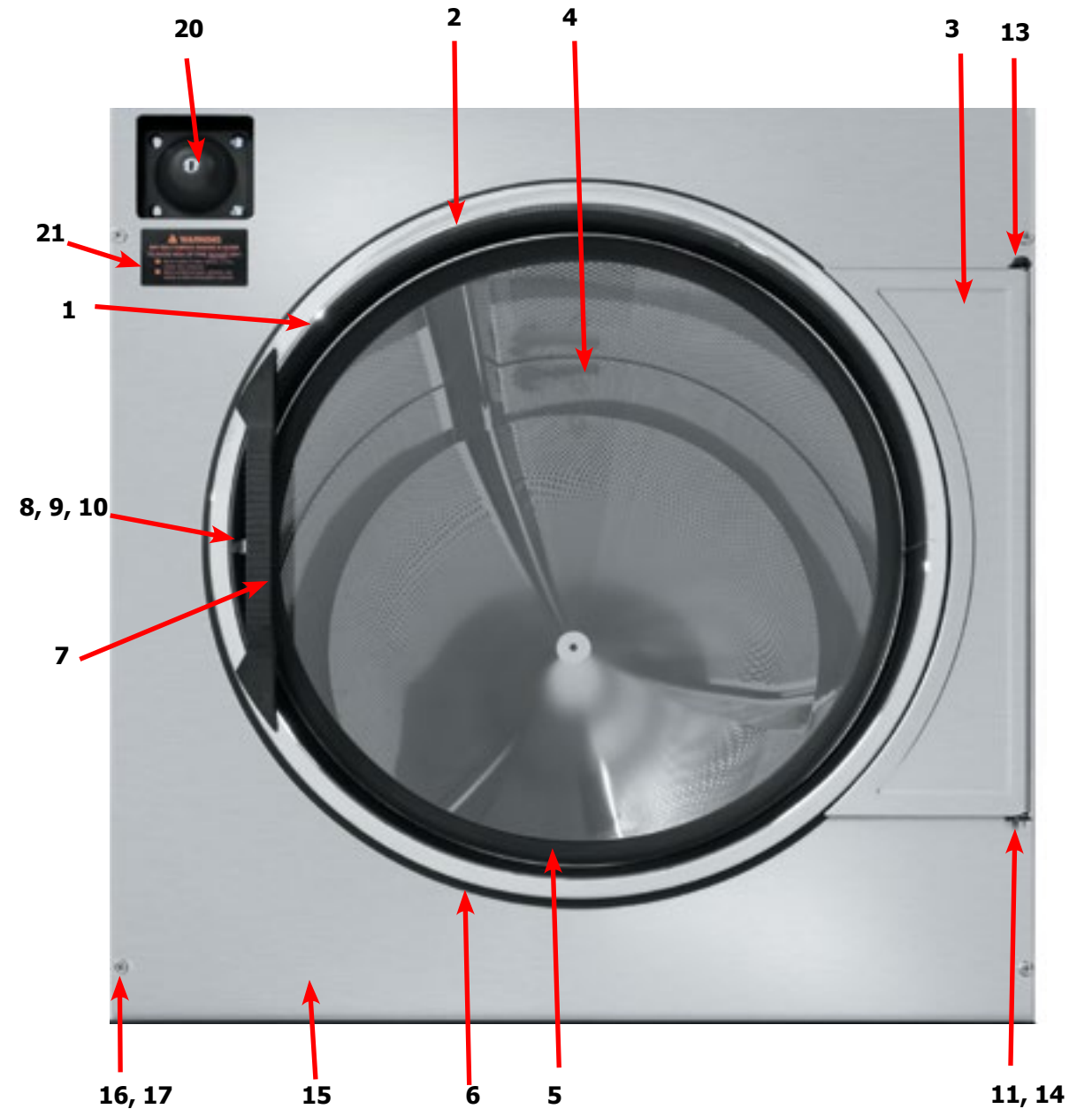

Key	Description	T-30	T-50	T-80	QTY
20	Coin Box Blue	9807-099-002	9807-099-002	9807-099-002	1
20	Coin Box Black	9807-099-004	9807-099-004	9807-099-004	1
21	Label-Warning, Dryer (Blue)	8502-758-002	8502-758-002	8502-758-002	1
21	Label-Warning, Dryer (Black)	8502-758-001	8502-758-001	8502-758-001	1
*	Label-Warning, French, Spanish	8502-764-001	8502-764-001	8502-764-001	1
*	Cabinet Touch Up Paint (White)	9472-001-013	9472-001-013	9472-001-013	1

Dryer Cabinet Group Continued

Key	Description	T-30	T-50	T-80	QTY
1	Nameplate - Dexter Dryer Blue	9412-216-002	9412-216-002	9412-216-002	1
1	Nameplate - Dexter Dryer Black	9412-216-001	9412-216-001	9412-216-001	1
2	Door Assy-Upper, Coin (SS)	9960-311-001	9960-312-001	9960-313-001	1
2	Door Assy-Upper, Coin (Wht)	9960-311-003	9960-312-003	9960-313-003	1
3	Bracket-Hinge	9029-224-001	9029-224-001	9029-224-001	2
*	Rivet- 3/16, Hinge to Door	9491-009-001	9491-009-001	9491-009-001	2
*	Rivet- 3/16, Hinge to Cabinet	9491-009-001	9491-009-001	9491-009-001	AR
4	Trim-Upper Service Door, Black	9578-098-002	9578-094-002	9578-096-002	1
5	Screw-Phillips, 10Bx3/8, Black	9545-008-010	9545-008-010	9545-008-010	4
6	Lock Assy. and Key Upper	8650-012-003	8650-012-003	8650-012-003	1
7	Cam Lock Upper Door	9095-047-001	9095-047-001	9095-047-001	1
*	Lock Spacer	9538-189-001	9538-189-001	9538-189-001	*
*	Key, 6324	6292-006-007	6292-006-007	6292-006-007	1
8	Overlay-Control, Coin, Blue	9435-042-002	9435-046-002	9435-047-002	1
8	Overlay-Control, Coin, Black	9435-042-001	9435-046-001	9435-047-001	1
9	Button-Push, Control, Blue	9035-062-001	9035-062-001	9035-062-001	1
9	Button-Push, Control, Black	9035-062-002	9035-062-002	9035-062-002	1
*	Spacer-Push Button (Micro)	9538-192-001	9538-192-001	9538-192-001	2
*	Retainer-Push Button (Micro)	9486-150-001	9486-150-001	9486-150-001	2
*	Nut, Hex-Elastistop, #4-40	8640-424-002	8640-424-002	8640-424-002	2
10	PCB-Controler	9471-022-001	9471-022-001	9471-022-001	1
*	Spacer-#6 x 9/16	9538-157-018	9538-157-018	9538-157-018	3
*	Spacer #6 x 7/8	9538-157-017	9538-157-017	9538-157-017	2
*	Nut- #6-32	8640-411-003	8640-411-003	8640-411-003	4
	Nut- #6-32 (Grounding nut)	8640-411-001	8640-411-001	8640-411-001	1
11	Wire Assy-GRN, 24"	8220-137-001	8220-137-001	8220-137-001	1
*	Harness, Main	9627-912-001	9627-912-002	9627-912-003	1
12	Support-Upper Service Door	9548-288-001	9548-288-002	9548-288-002	1
13	Clamp-Tube	9079-121-002	9079-121-002	9079-121-002	2
14	Nut, #6-32	8640-411-003	8640-411-003	8640-411-003	2
15	Clamp-Cable, 1/2"	8654-125-006	8654-125-006	8654-125-006	1
*	Nut, #6-32	8640-411-003	8640-411-003	8640-411-003	1
16	Insulation	9277-041-016	9277-041-016	9277-041-016	1
17	Coin Acceptor	9021-093-001	9021-093-001	9021-093-001	1
18	Retainer-Coin Acceptor	9486-149-001	9486-149-001	9486-149-001	2
19	Screws-Torq, 4Bx5/8 ss	9545-053-002	9545-053-002	9545-053-002	4
*	Switch Assembly, Optical	9801-099-001	9801-099-001	9801-099-001	1
*	Coin Chute	9940-017-001	9940-017-001	9940-017-001	1
*	Screw	9545-008-001	9545-008-001	9545-008-001	1
*	Thumb Drive	9150-045-002	9150-045-002	9150-045-002	1
*	Nut, Elastic Stop	8640-413-004	8640-413-004	8640-413-004	*

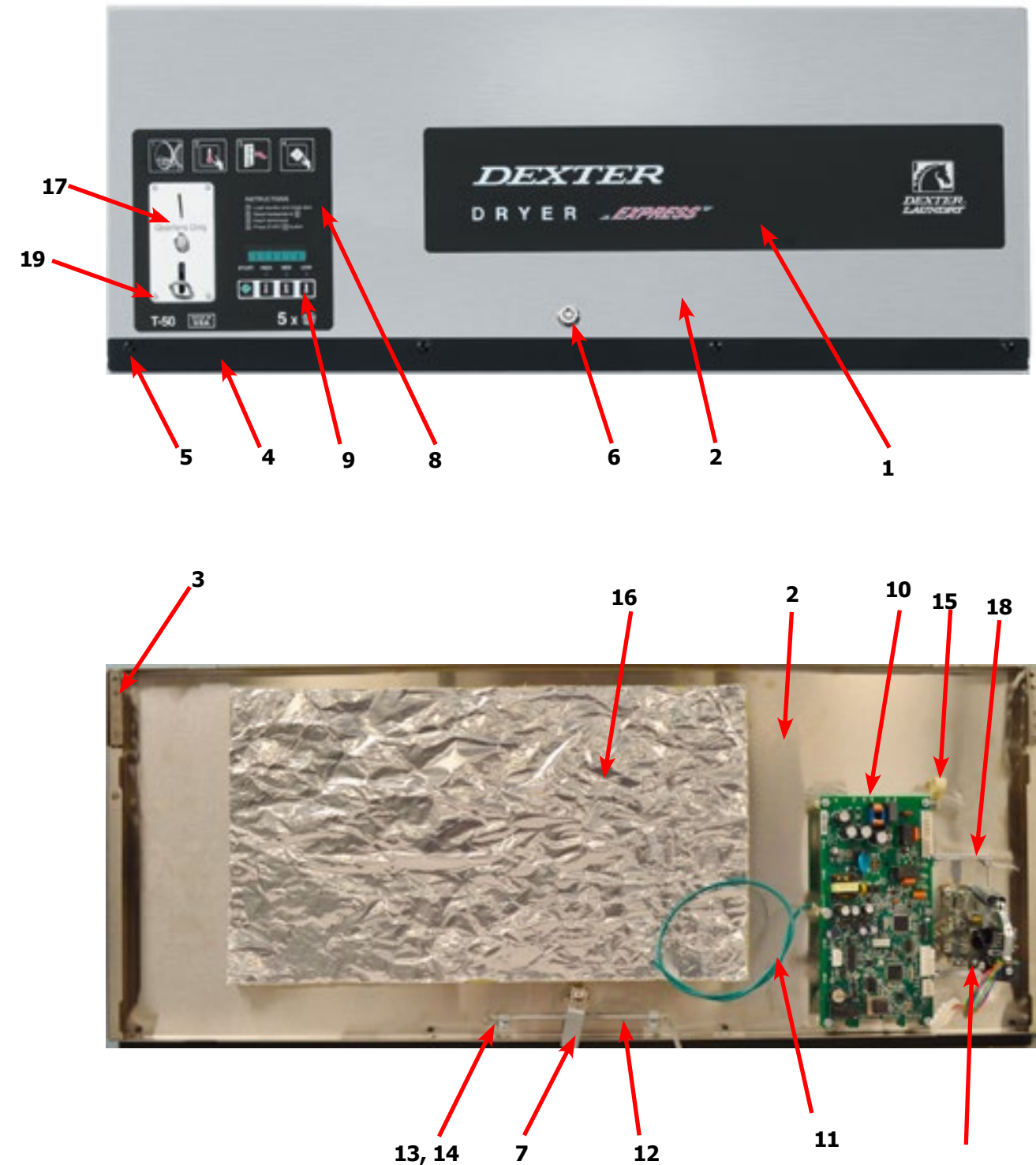

Dryer Cabinet Group Continued

Key	Description	T-30	T-50	T-80	QTY
1	Door-Lower Service, Coin, SS	9108-130-001	9108-122-001	9108-126-001	1
1	Door-Lower Service, Coin, Wht	9108-130-003	9108-122-003	9108-126-003	1
2	Lock Assy. and Key Lower Door	8650-012-004	8650-012-004	8650-012-004	1
*	Cam Lock Lower Door	9095-048-001	9095-048-001	9095-048-001	1
*	Lock Spacer	9538-189-001	9538-189-001	9538-189-001	*
*	Washer-Flat	8641-581-041	8641-581-041	8641-581-041	2
3	Handle-Door, Lower Service	9244-084-002	9244-087-002	9244-088-002	1
4	Screw-Phillips, 10Bx3/8, Black	9545-008-010	9545-008-010	9545-008-010	5
5	Trim-Lower Kick, Black	9578-099-002	9578-095-002	9578-097-002	1
6	Screw-Phillips, 10Bx3/8, Black	9545-008-010	9545-008-010	9545-008-010	4
7	Screen Assy, Lint	9822-026-002	9822-026-001	9822-031-002	1
8	Switch-Door Closure (Square)	9539-501-001	9539-501-001	9539-501-001	1
8	Switch-Door Closure (Round)	9539-492-001	9539-492-001	9539-492-001	1
*	Kit, Optional Replacement for Round Switch 9539-492-001	9732-351-001	9732-351-001	9732-351-001	1
9	Hinge-Door, Lower	9243-081-001	9243-082-001	9243-082-001	1
10	Screw-5/16, 10ABx3/8	9545-008-024	9545-008-024	9545-008-024	5
11	Bracket-Door Switch	9029-226-001	9029-226-001	9029-226-001	1
*	Rivet, 1/8 Low Profile	9491-009-004	9491-009-004	9491-009-004	2
12	Bracket-Chain	9029-223-001	9029-223-001	9029-223-001	2
*	Rivet, 1/8 Low Profile	9491-009-004	9491-009-004	9491-009-004	8
13	Hook, "S" Type	9248-022-002	9248-022-002	9248-022-002	4
14	Chain	9099-012-006	9099-012-006	9099-012-006	2
*	Leg, Leveling 1/2"	8544-006-001	8544-006-001	8544-006-001	4

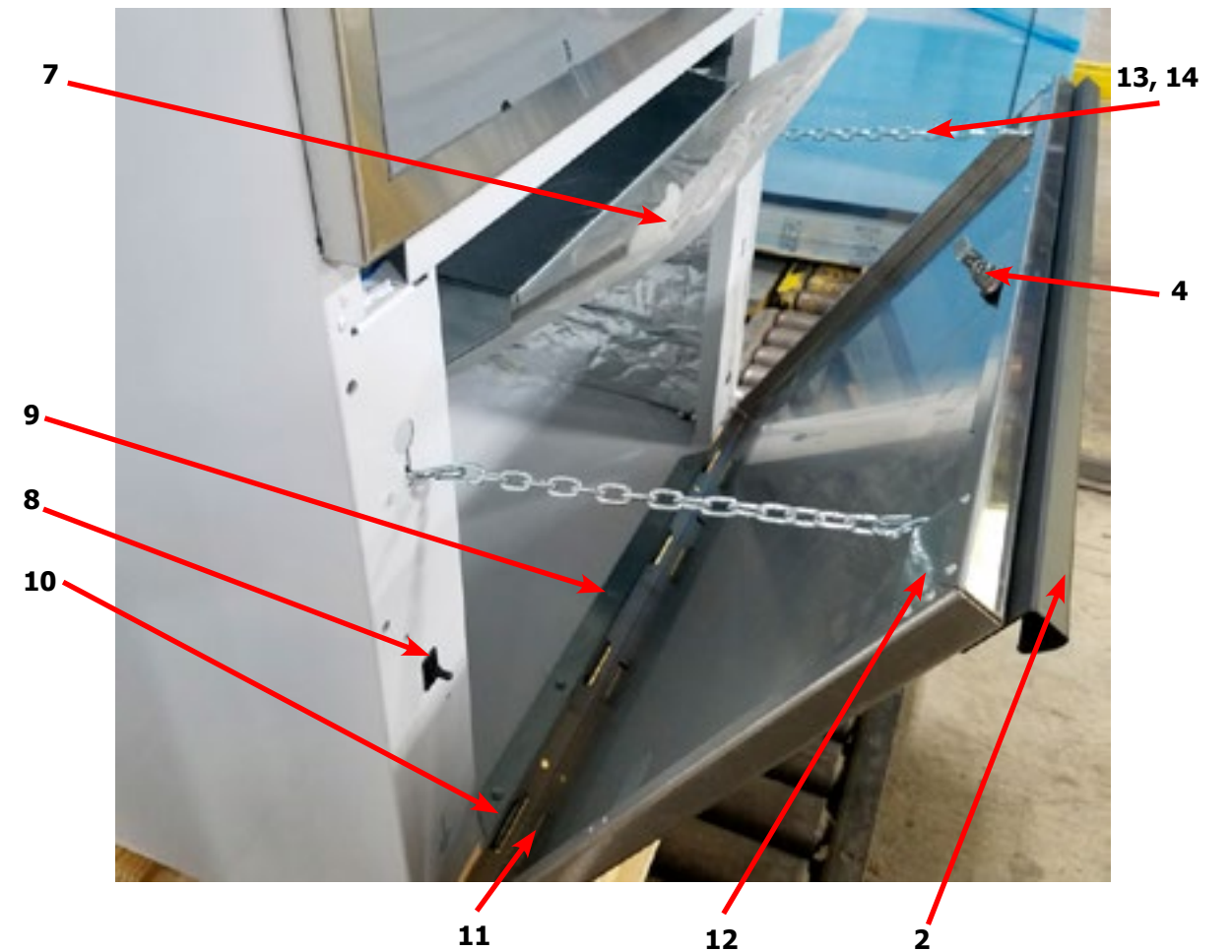
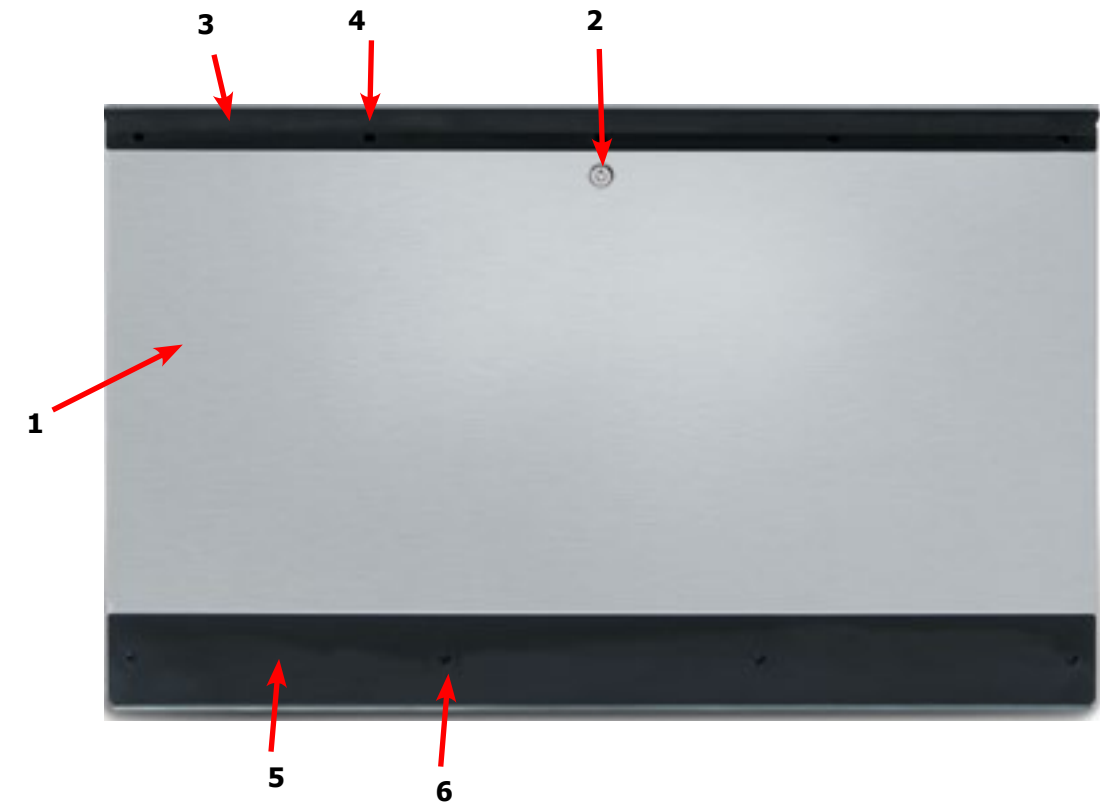

Dryer Cabinet Group Continued

Key	Description	T-30	T-50	T-80	QTY
1	Insulation, Upper service Door	9277-041-006	9277-041-016	9277-041-016	1
2	Insulation, RH Burner	9277-041-019	9277-041-019	9277-041-023	1
3	Insulation Tumbler Area, above Baffle	9277-041-020	9277-051-003	9277-041-021	2
3	Insulation Tumbler Area, above Baffle		9277-051-003	9277-041-021	2
4	Insulation Tumbler Area, below baffle	9277-041-020	9277-051-003	9277-051-004	2
4	Insulation Tumbler Area, below baffle		9277-051-003	9277-051-004	2
5	Insulation Lint Compartment	9277-041-021	9241-041-024	9277-041-025	2
*	Screen Assy, Lint	9822-026-002	9822-026-001	9822-031-002	1
6	Switch-Door Closure (Round)	9539-492-001	9539-492-001	9539-492-001	1
6	Switch-Door Closure (Square)	9539-501-001	9539-501-001	9539-501-001	1
7	Hinge-Door, Lower	9243-081-001	9243-082-001	9243-082-001	1
8	Screw-5/16, 10ABx3/8	9545-008-024	9545-008-024	9545-008-024	AR
9	Lint Hood-Back	9240-038-001	9240-041-001	9240-044-001	1
10	Nut Wizlock, 8-32	8640-412-004	8640-412-004	8640-412-004	6
11	Lint hood, LH	9240-040-001	9240-043-001	9240-046-001	1
12	Lint hood, RH	9240-040-002	9240-043-002	9240-046-002	1
13	Lint hood, Top	9240-039-001	9240-042-001	9240-045-001	1
14	Screw, 5/16- 10ABx3/8	9545-008-024	9545-008-024	9545-008-024	14
15	Impeller, w/ set screws	9278-043-001	9278-038-004	9278-037-003	1
16	Harness -Temp Probe	9627-679-002	9627-679-002	9627-679-002	1
17	Wire Nut, #71B	8640-276-005	8640-276-005	8640-276-005	2
18	Bracket, Temp Probe	9029-197-001	NA	NA	1
19	Screw-5/16, 10ABx3/8	9545-008-024	NA	NA	1
20	Temp Probe	9501-004-002	9501-004-002	9501-004-002	1
21	Screw-Phillips, 8Bx1/4	9545-045-005	9545-045-005	9545-045-005	1
22	Vault, Coin	9942-039-002	9942-039-002	9942-039-002	1
*	Plate Assy./Coin vault mounting	9982-338-001	9982-338-001	9982-338-001	1
*	Nut/ Hex elastic stop	8640-413-004	8640-413-004	8640-413-004	2
23	Coin Chute	9940-017-001	9940-017-001	9940-017-001	1
*	Screw, 10Bx1/4	9545-008-001	9545-008-001	9545-008-001	1
24	Harness, Main	9627-912-001	9627-912-002	9627-912-003	1

30Lb. Temp Probe

50Lb. & 80Lb. Temp Probe

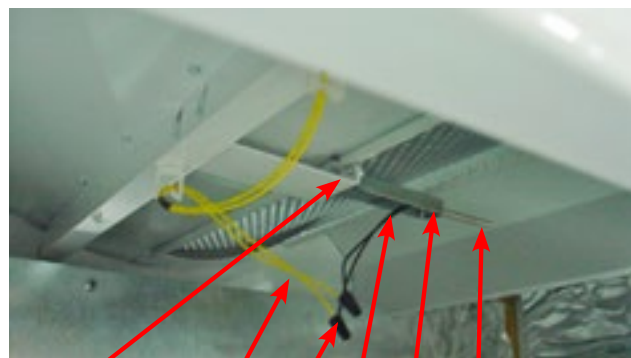

19 16 17 18 21 20

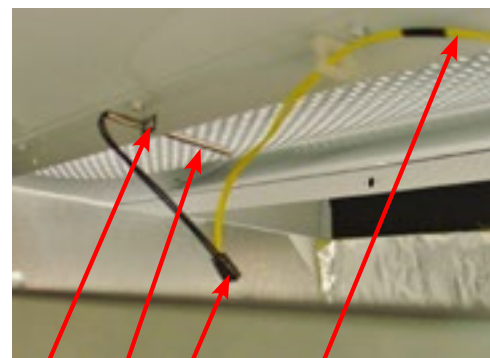

21 20 17 16

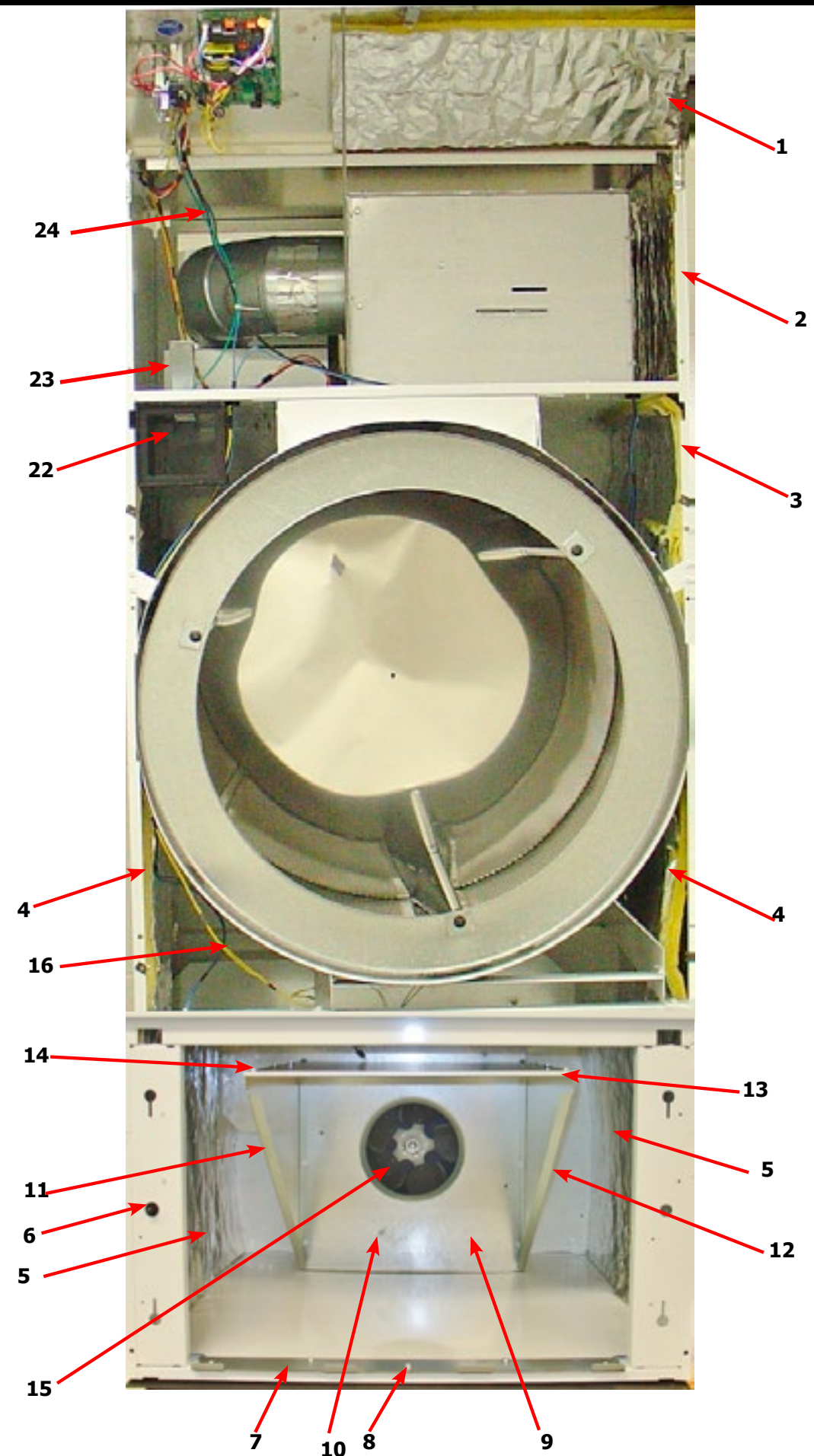

Dryer Modular Cabinet Group 30lb. (After Serial D1.23164.026)

Key	Description	T30	QTY
1	Cabinet Base Assembly	9945-166-001	1
*	Lower Back Panel Assembly	9989-730-002	1
2	Lower Cabinet RH Side Panel	9444-109-003	1
3	Lower Cabinet LH Side Panel	9444-109-004	1
4	Lower Cabinet Front Channel	9081-224-001	1
*	Upper Back Panel Assembly	9989-731-002	1
5	RH Middle Side Panel Assembly	9444-111-003	1
6	LH Middle Side Panel Assembly	9444-111-004	1
7	Cabinet Top	9577-070-001	1
8	RH Baffle	9049-131-001	1
9	LH Baffle	9049-132-001	1
*	Baffle Angled Bracket	9029-371-001	2
*	Baffle Reinforcement	9489-059-001	3
*	Baffle Reinforcement with Thermistor Mount	9489-060-001	1
10	RH Upper Side Panel	9444-113-003	1
11	LH Upper Side Panel	9444-113-004	1
12	Upper Cross Brace	9046-107-001	1
*	10abx3/8 Screw	9545-008-024	25
*	3/16 Blind Rivet	9491-009-001	171
*	Wht 3/16 Blind Rivet	9491-009-005	48

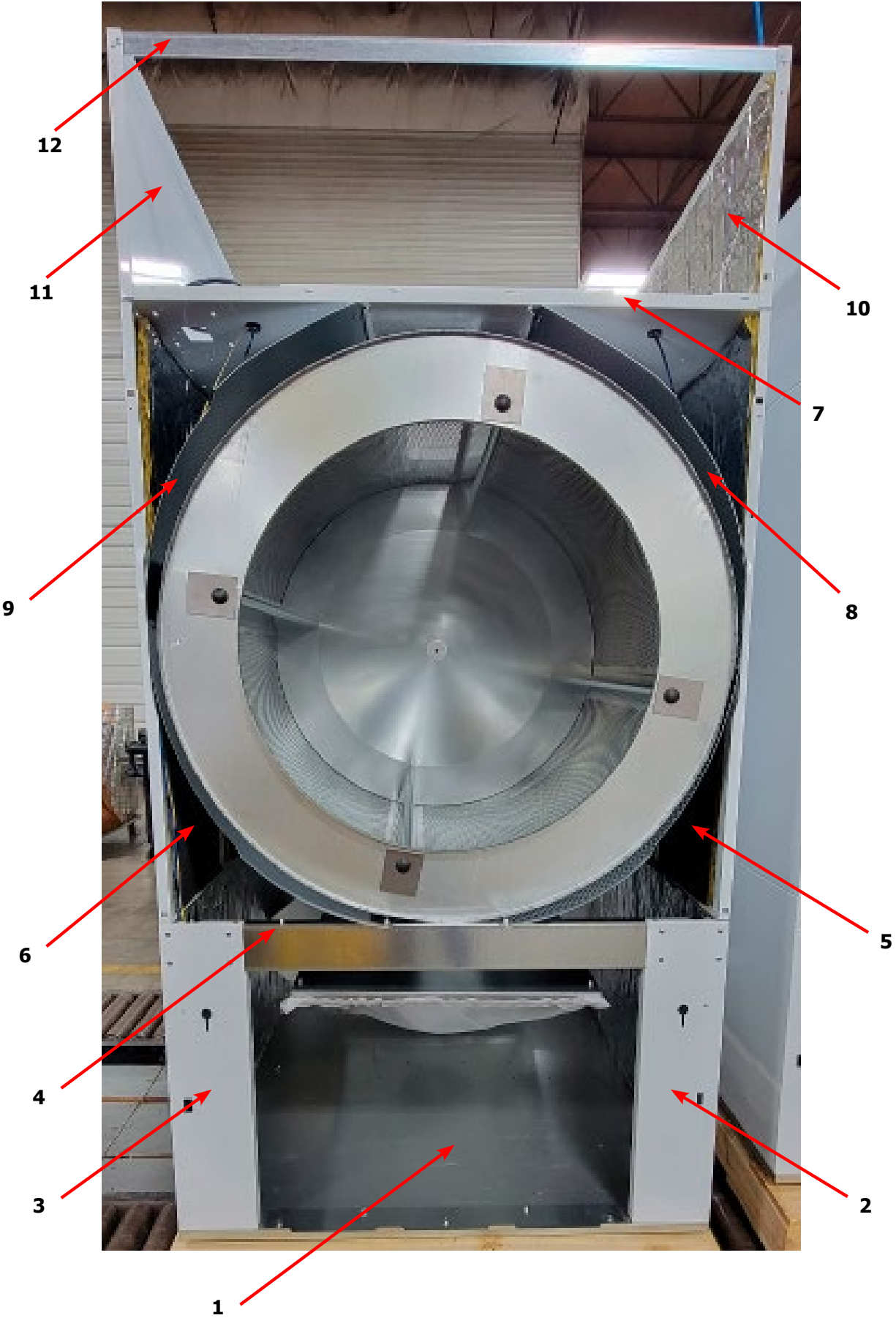

Dryer Modular Cabinet Group 50lb. (After Serial D1.23145.014)

Key	Description	T50	QTY
1	Cabinet Base Assembly	9945-165-001	1
*	Lower Back Panel Assembly	9989-726-002	1
2	Lower Cabinet RH Side Panel	9444-104-003	1
3	Lower Cabinet LH Side Panel	9444-104-004	1
4	Lower Cabinet Front Channel	9081-222-001	1
*	Upper Back Panel Assembly	9989-727-002	1
5	RH Middle Side Panel Assembly	9989-728-003	1
6	LH Middle Side Panel Assembly	9989-728-004	1
7	Cabinet Top Assembly	9961-164-001	1
8	RH Baffle	9049-130-001	1
9	LH Baffle	9049-130-002	1
*	Baffle Stiffener Angle	9003-386-001	2
10	RH Upper Side Panel	9444-108-003	1
11	LH Upper Side Panel	9444-108-004	1
12	Upper Cross Brace	9046-105-001	1
*	10abx3/8 Screw	9545-008-024	21
*	Large Head Pop Rivet	8638-190-028	4
*	3/16 Blind Rivet	9491-009-001	122
*	Wht 3/16 Blind Rivet	9491-009-005	54

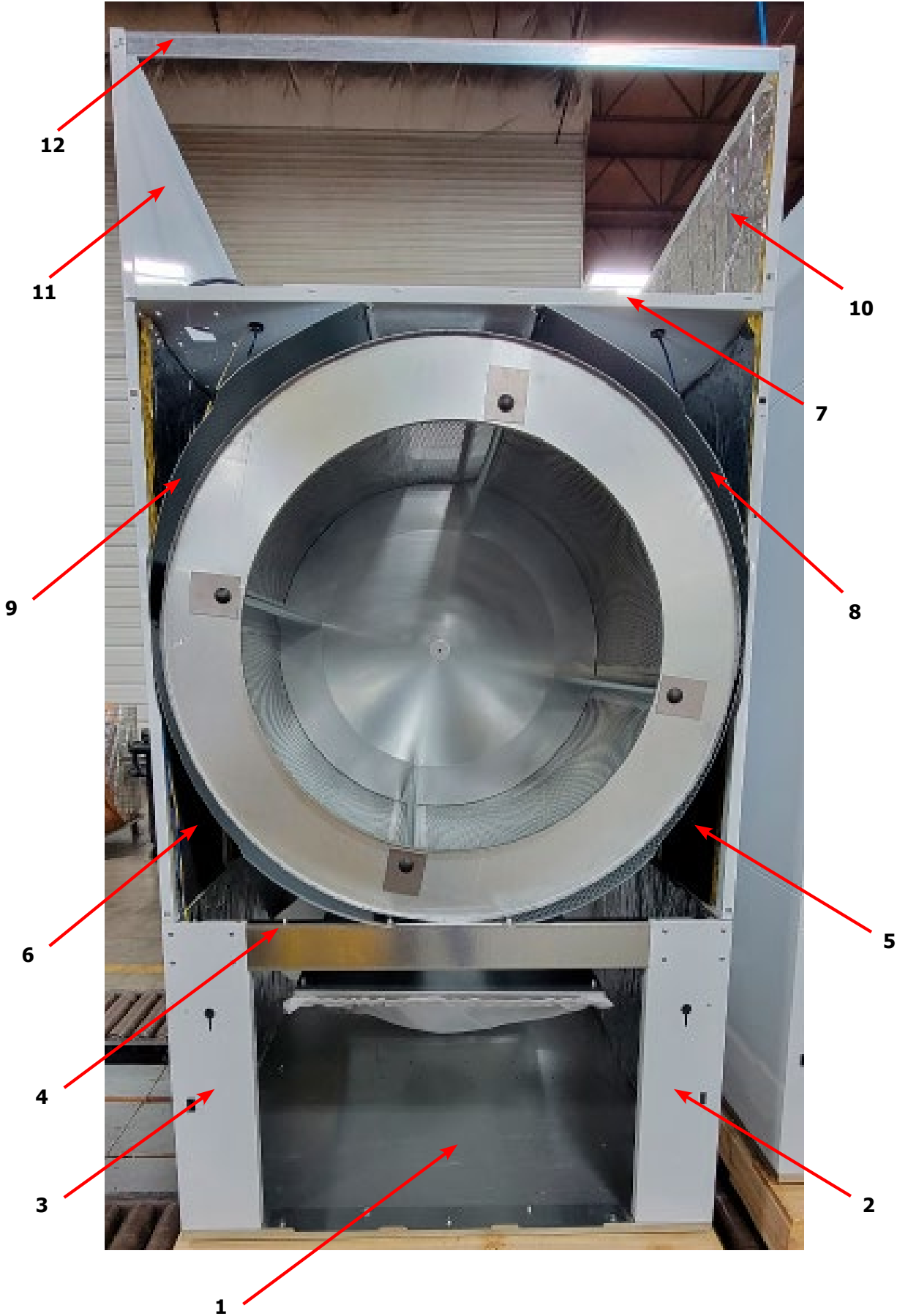

Dryer Modular Cabinet Group 80lb. (After Serial D1.23090.024)

Key	Description	T80	QTY
1	Cabinet Base Assembly	9945-162-001	1
*	Lower Back Panel Assembly	9989-716-002	1
2	Lower Cabinet RH Side Panel	9444-091-003	1
3	Lower Cabinet LH Side Panel	9444-091-004	1
4	Lower Cabinet Front Channel	9081-217-001	1
*	Upper Back Panel Assembly	9989-717-002	1
5	RH Middle Side Panel Assembly	9989-718-003	1
6	LH Middle Side Panel Assembly	9989-718-004	1
7	Cabinet Top Assembly	9961-163-002	1
8	RH Baffle	9049-129-001	1
9	LH Baffle	9049-129-002	1
*	Baffle Stiffener Angle	9003-384-001	2
10	RH Upper Side Panel	9444-095-003	1
11	LH Upper Side Panel	9444-095-004	1
12	Upper Cross Brace	9046-104-001	1
*	Heavy Hex Nut 7/16-14	8640-416-001	6
*	Spring Lockwasher 7/16	8641-582-013	6
*	10abx3/8 Screw	9545-008-024	28
*	Large Head Pop Rivet	8638-190-028	4
*	3/16 Blind Rivet	9491-009-001	111
*	Wht 3/16 Blind Rivet	9491-009-005	54
*	Hex kep Nut 1/4-20unc, 2b	8640-414-006	10
*	LH Rear Side Angle	9003-326-002	1
*	RH Rear Side Angle	9003-327-002	1

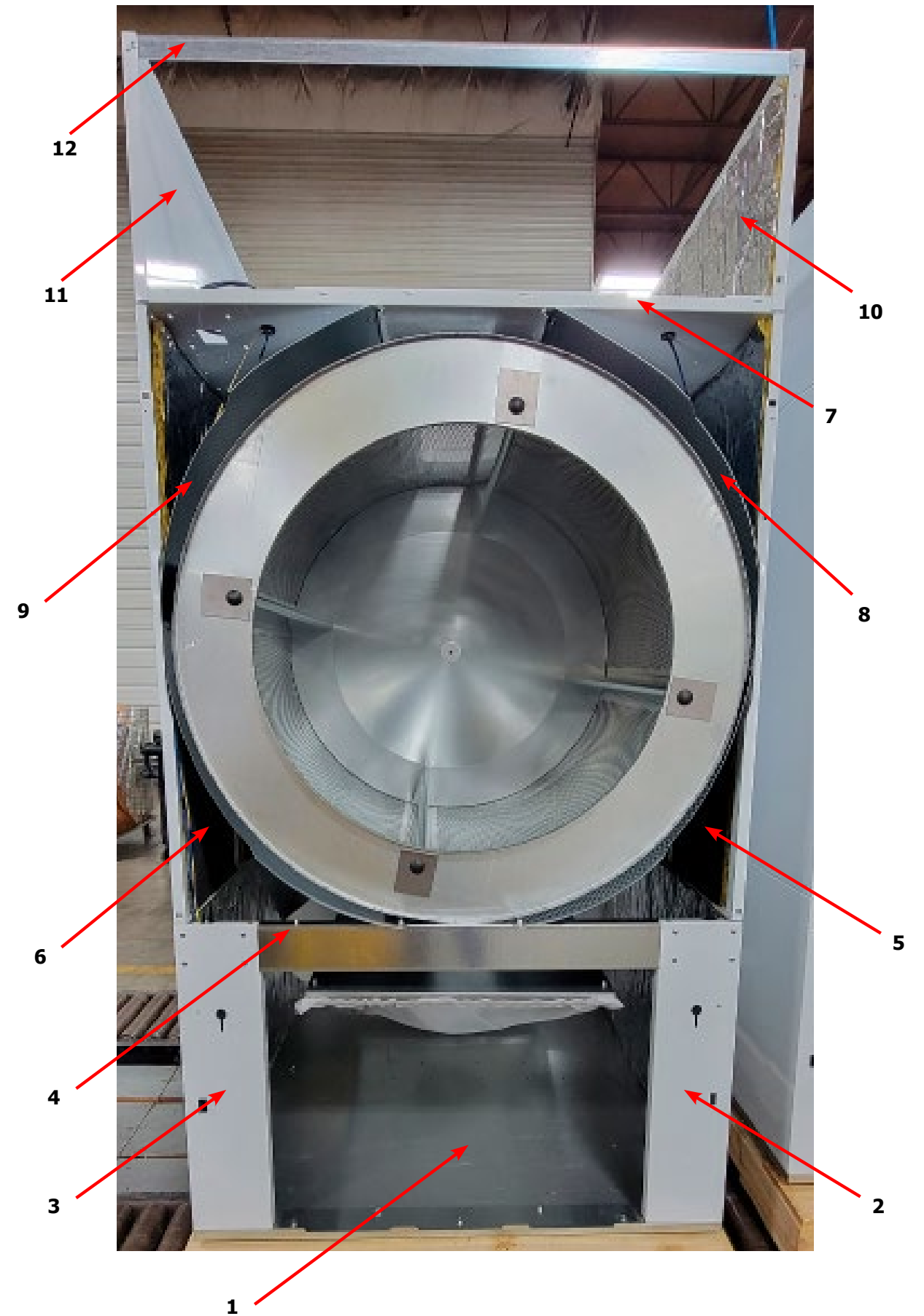

Dryer Rear View 30Lb

Key	Description	T-30	QTY
1	Motor	9376-311-003	1
2	Pulley	9453-157-001	1
*	Set screw	9545-028-013	1
3	Plate, Motor mounting	9982-370-002	1
*	Gasket, Motor Plate	9206-428-001	1
4	Nut-3/8-16, Plate to cabinet	8640-415-004	4
*	Impeller w/ set screw	9278-043-001	1
5	Screw, 5/16-18x5/8	9545-014-004	4
6	Nut, 3/8-16	8640-415-004	4
7	Support Arm, Intermediate pulley	9991-053-001	1
8	Bolt- 3/8-16x1 1/4	9545-029-010	3
9	Nut, Wizlock, 3/8x16	8640-415-004	3
*	Cap Screw, 3/8-16x1 1/2	9545-029-003	1
*	Snap Ring	9487-200-003	1
*	Washer-Flat, 3/8x1	8641-581-020	1
10	Idler Arm Assembly	9861-022-001	1
11	Washer-Flat, 3/8x1	8641-581-020	2
12	Pulley, Idler w/ Bearings	9908-039-004	1
13	Bearing, Bronze	9036-145-002	2
14	Snap Ring	9487-200-003	1
15	Hook "S" type	9248-022-002	3
16	Chain, Spring tension	9099-012-002	1
17	Spring, tension	9534-319-002	1
18	Chain, Limit	9099-012-007	1
19	Belt Drive	9040-076-003	1
*	Tolerance Ring	9487-234-005	1
20	Pulley, Driven	9908-049-002	1
21	Washer-Flat, 1/2	8641-581-021	1
22	Washer-Lock, Ext. tooth, 1/2	8641-582-016	1
23	Bolt-3/4, 1/2-13x1/14	9545-017-019	1
24	Belt, Driven	9040-073-009	1

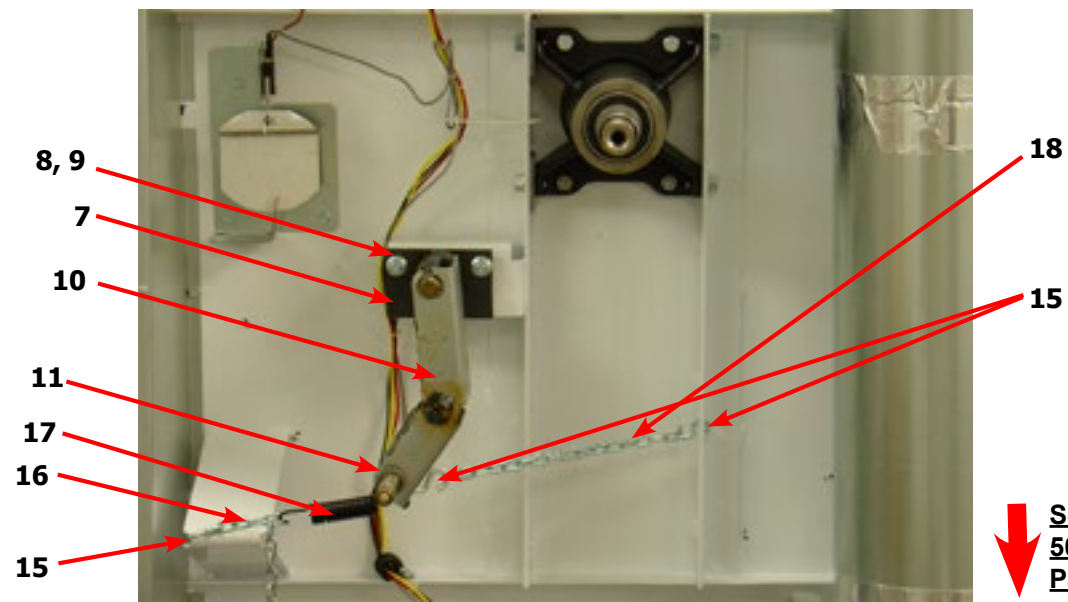

↓ Scroll down for
50lb and 80lb
Parts Breakdown

Dryer Rear View 30Lb

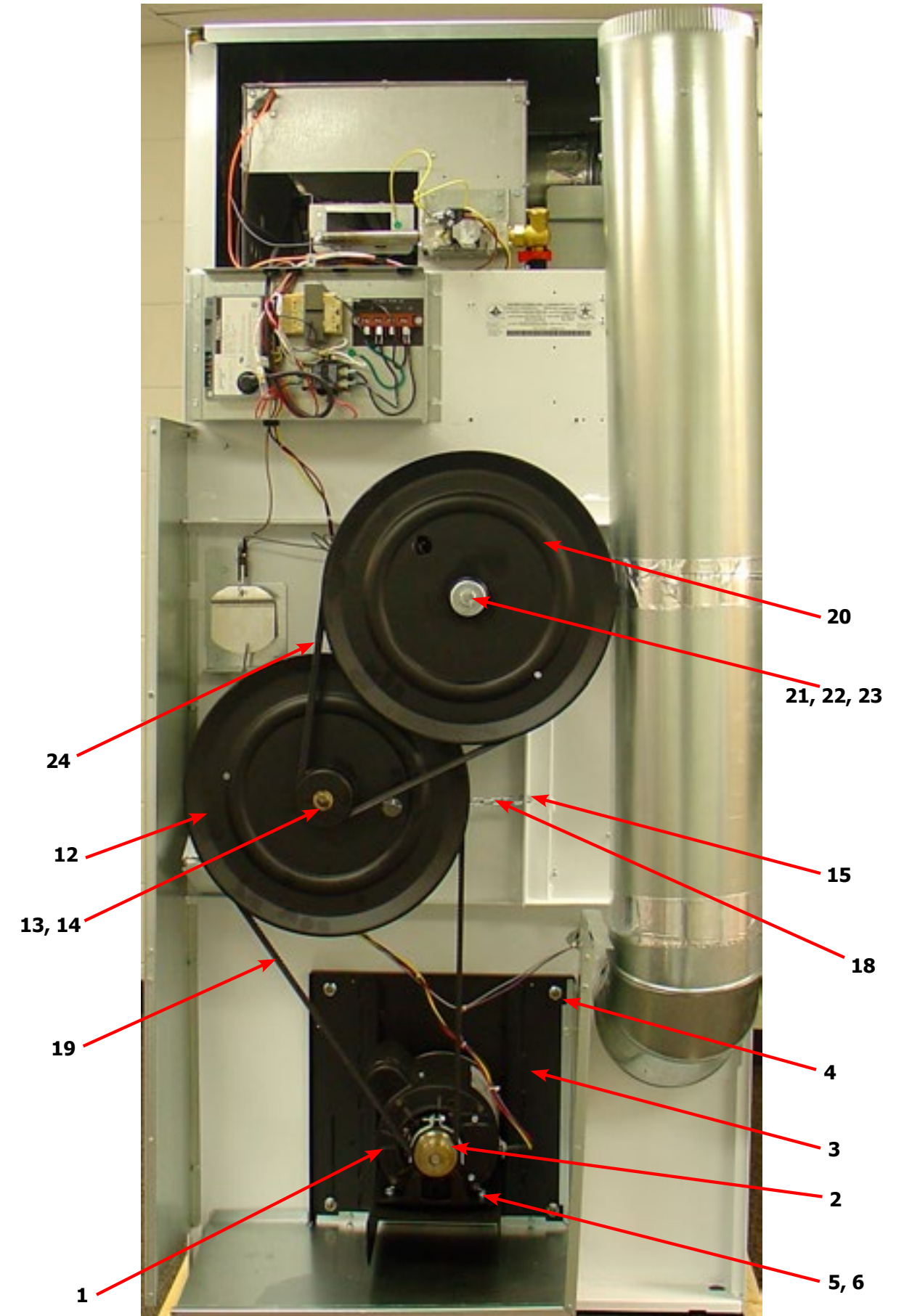

Dryer Rear View 50 Lb

Key	Description	T-50	QTY
1	Motor	9376-317-003	1
*	Run Capacitor, Motor	5191-108-001	1
*	Start Capacitor, Motor	5191-109-001	1
2	Pulley	9453-169-013	1
*	Set screw	9545-028-013	1
3	Plate, Motor mounting	9982-370-002	1
*	Gasket, Motor Plate	9206-428-001	1
4	Nut-3/8-16, Plate to cabinet	8640-415-004	4
*	Impeller w/ set screw	9278-038-004	1
5	Screw, 5/16-18x5/8	9545-014-004	4
6	Nut, 3/8-16	8640-415-004	4
7	Support Arm, Intermediate pulley	9991-053-002	1
8	Bolt- 3/8-16x1 1/4	9545-029-010	3
9	Nut, Wizlock, 3/8x16	8640-415-004	3
*	Cap Screw, 3/8-16x1 1/2	9545-029-012	1
*	Snap Ring	9487-200-003	1
*	Washer-Flat, 3/8x1	8641-581-035	1
10	Idler Arm Assembly	9861-022-002	1
*	Snap Ring (Support Arm keeper)	9487-200-003	1
*	Snap Ring	9487-200-003	1
*	Washer-Flat, 3/8x1	8641-581-035	1
11	Pulley, Idler w/ Bearings	9908-048-003	1
12	Bearing, Bronze	9036-145-002	2
13	Snap Ring	9487-200-003	1
14	Hook "S" type	9248-022-002	3
15	Chain, Spring tension	9099-012-002	1
16	Spring, tension	9534-369-001	1
17	Belt Drive	9040-076-006	1
*	Tolerance Ring	9487-234-005	1
18	Pulley, Driven	9908-047-002	1
19	Washer-Flat, 1/2	8641-581-026	1
20	Washer-Lock, Ext. tooth, 1/2	8641-582-016	1
21	Bolt-3/4, 1/2-13x1/14	9545-017-009	1
22	Belt, Driven	9040-073-011	1
23	Thermostat-Overtemp, Reset	9576-207-006	1

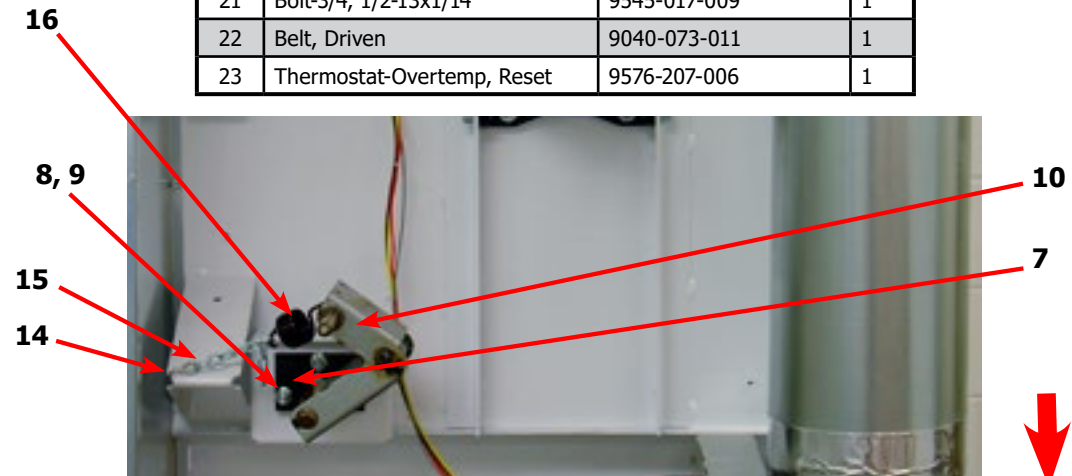

↓ **Scroll down for
80lb Parts
Breakdown**

Dryer Rear View 50 Lb

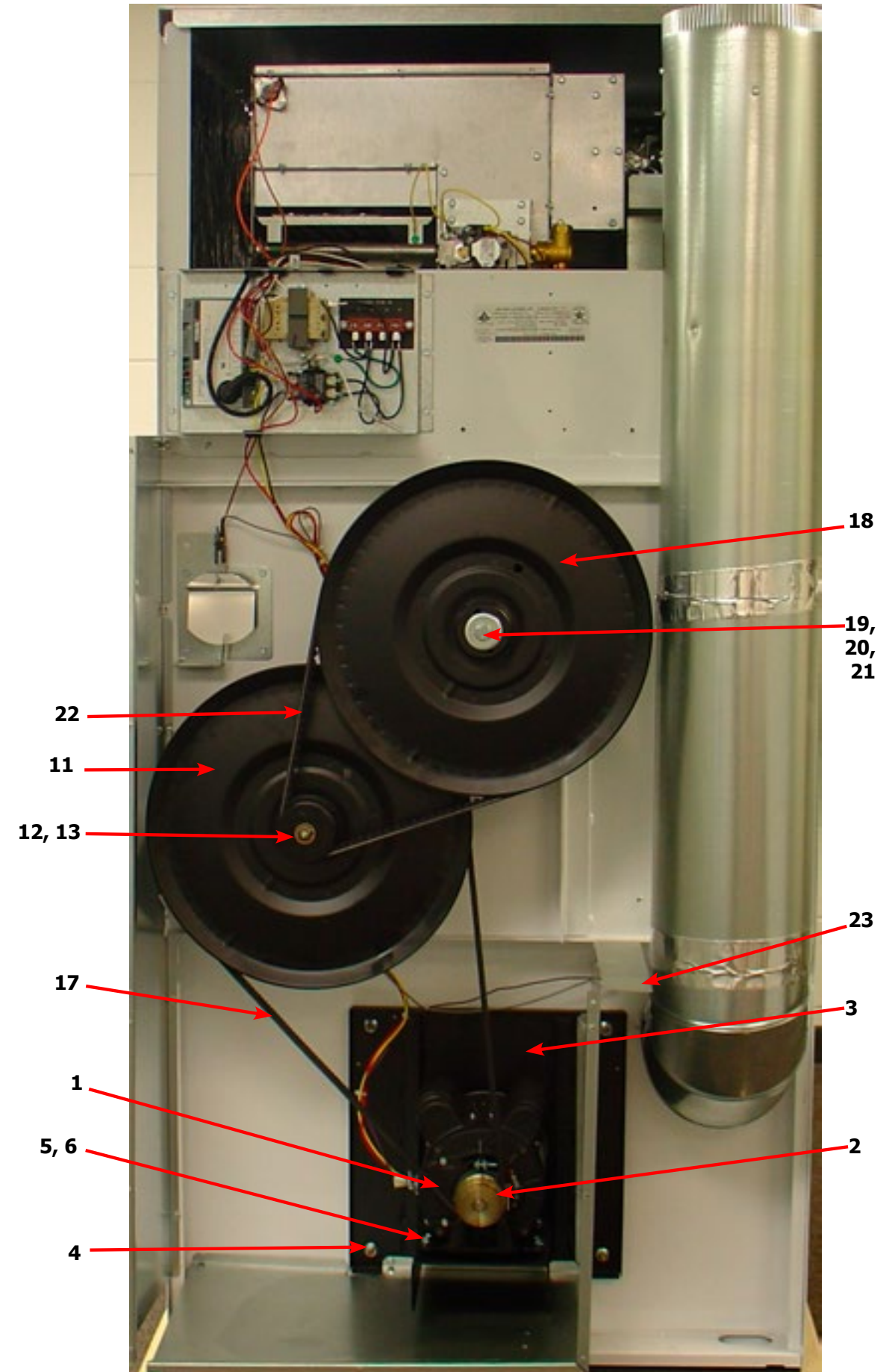

Dryer Rear View 80 Lb

Key	Description	T-80	QTY
1	Motor	9376-317-003	1
*	Run Capacitor, Motor	5191-108-001	1
*	Start Capacitor, Motor	5191-109-001	1
2	Pulley	9453-157-001	1
*	Set screw	9545-028-013	1
3	Plate, Motor mounting	9982-372-002	1
*	Gasket, Motor Plate	9206-428-001	1
4	Nut-3/8-16, Plate to cabinet	8640-415-004	4
*	Impeller w/ set screw	9278-037-003	1
5	Screw, 5/16-18x5/8	9545-014-004	4
6	Nut, 3/8-16	8640-400-003	4
*	Tolerance Ring	9487-234-001	1
7	Pulley, Driven	9908-043-002	1
8	Washer-Flat, 1/2	8641-581-026	1
9	Washer-Lock, Ext. tooth, 1/2	8641-582-016	1
10	Bolt-3/4, 1/2-13x1/4	9545-017-009	1
11	Support Arm, Intermediate pulley	9991-053-002	1
12	Bolt- 3/8-16x1 1/4	9545-029-010	3
13	Nut, Wizlock, 3/8x16	8640-415-004	3
*	Cap Screw, 3/8-16x1 1/2	9545-029-002	1
*	Snap Ring	9487-200-003	1
*	Washer-Flat, 3/8x1	8641-581-020	1
14	Idler Arm Assembly	9861-024-004	1
*	Snap Ring	9487-200-006	
*	Washer-Flat, 3/8x1	8641-581-039	1
15	Pulley, Idler w /Bearings	9908-042-006	1
*	Snapring, Inside-Bearing	9487-238-005	1
*	Bearing, Ball	9036-159-007	2
*	Spacer, Bearing	9538-173-002	1
16	Washer-Flat	8641-581-039	1
17	Nut, 5/8-11	8640-425-002	1
18	Hook "S" type	9248-022-002	3
19	Chain, Spring tension	9099-012-002	1
20	Spring, tension	9534-369-001	1
21	Belt Drive	9040-076-011	1
22	Belt, Driven	9040-073-012	1
23	Thermostat-Overtemp, Reset	9576-207-006	1

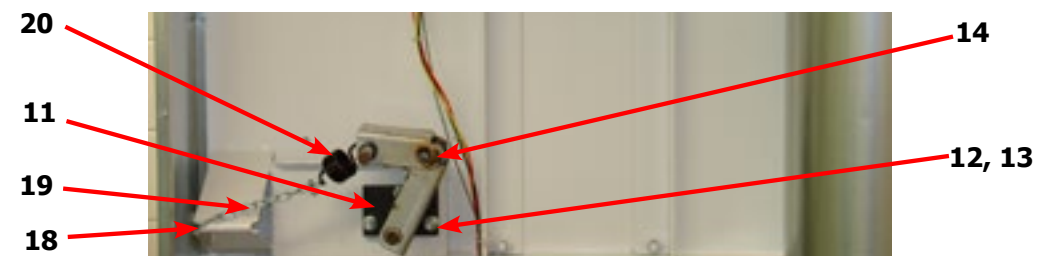

Dryer Rear View 80 Lb

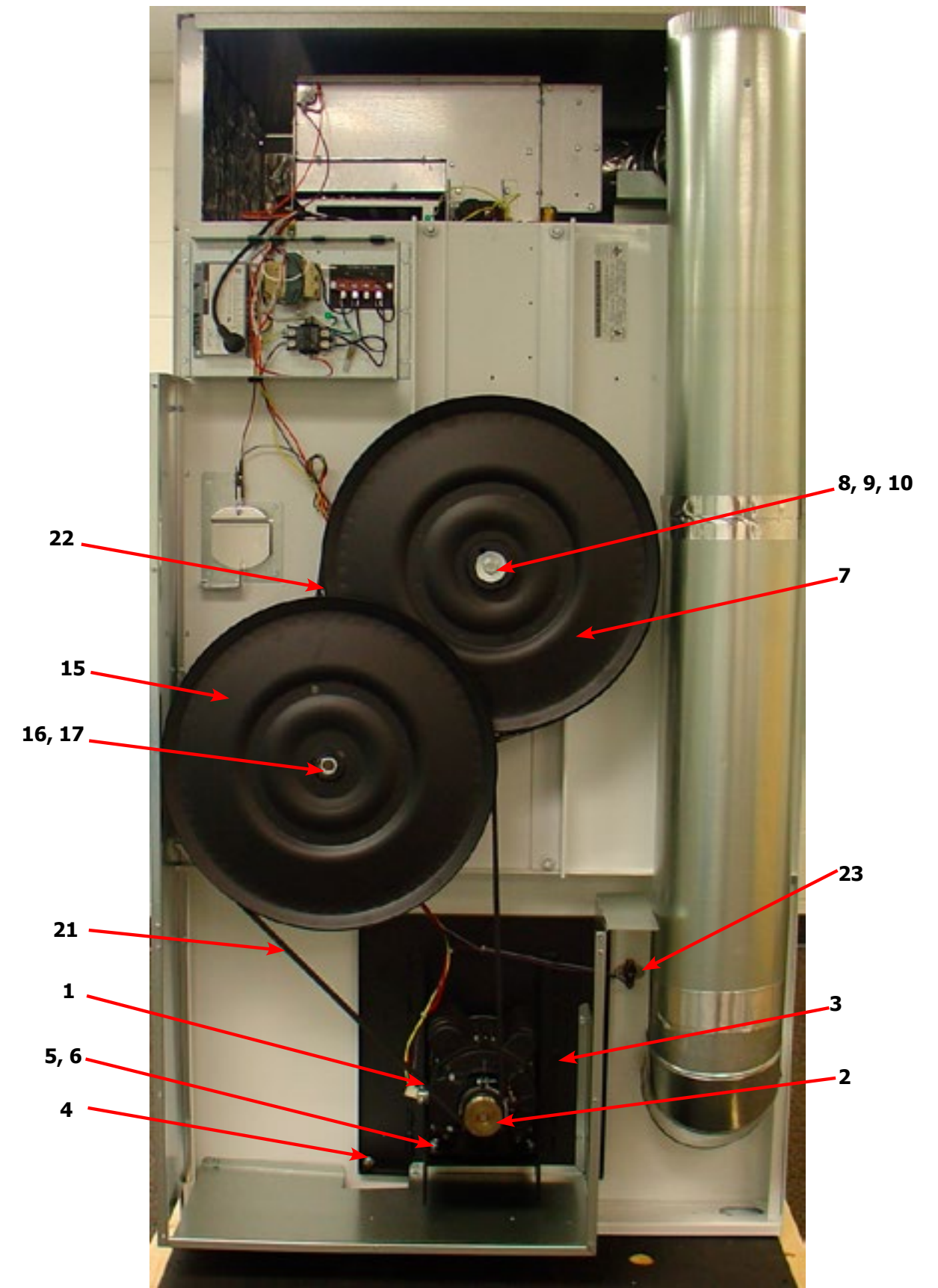

Dryer Rear View-Guard & Exhaust

Key	Description	T-30	T-50	T-80	QTY
1	Cover Cabinet	9074-347-001	9074-348-001	9074-349-001	1
*	Screw-5/16, 10ABx3/8	9545-008-024	9545-008-024	9545-008-024	AR
2	Cover-Control Box	9074-346-001	9074-346-001	9074-346-001	1
3	Screw-5/16, 10ABx3/8	9545-008-024	9545-008-024	9545-008-024	AR
4	Guard, RH	9208-093-001	9208-097-001	9208-101-001	1
*	Screw-5/16, 10ABx3/8	9545-008-024	9545-008-024	9545-008-024	AR
5	Guard Base & LH	9208-094-001	9208-098-001	9208-102-001	1
*	Screw-5/16, 10ABx3/8	9545-008-024	9545-008-024	9545-008-024	AR
6	Guard-Lower	9208-095-001	9208-099-002	9208-103-001	1
7	Screw-5/16, 10ABx3/8	9545-008-024	9545-008-024	9545-008-024	AR
8	Guard-upper	9208-096-001	9208-100-001	9208-104-001	1
*	Screw-5/16, 10ABx3/8	9545-008-024	9545-008-024	9545-008-024	AR
9	Elbow-90 degree, 8"	9042-039-001	9042-039-001	9042-039-001	1
10	Pipe-Duct, 8"	9109-121-001	9109-121-001	9109-121-002	1
11	Tee-Duct, Recirculation, 8"-6"	9810-018-001	9810-018-001	9810-019-001	1
12	Damper	9125-002-001	9125-002-001	9125-008-001	1
*	Pin-Damper, Hinge	9451-146-002	9451-146-002	9451-146-002	1
*	Nut-Spring	8520-141-000	8520-141-000	8520-141-000	2
13	Bracket-Recirculation Duct, Small	9029-228-001	9029-228-001	9028-228-001	1
14	Pipe-Duct, 6"	9109-122-001	9109-122-002	9109-122-003	1
15	Bracket-Duct, Recirculation Large	9029-246-001	9029-247-001	9029-247-001	1
16	Elbow-90 degree, 6"	9142-039-002	9142-039-002	9142-039-002	1
*	Operators Manual	8514-234-001	8514-234-001	8514-234-001	1
17	Diagram & Schematics	9506-546-001	9506-546-001	9506-546-001	1
18	Label-Warning & Notice	8502-763-001	8502-763-001	8502-6763-001	1
19	Label-Instructions	8502-645-001	8502-645-001	8502-645-001	1
20	Decal-Lighting & Clearance	8527-151-001	8527-151-001	8527-151-001	1
21	Label-High Voltage	8502-614-004	8502-614-004	8502-614-004	1
*	8" Slide Open Clean Out Duct	9973-034-001	9973-034-001	9973-034-001	1

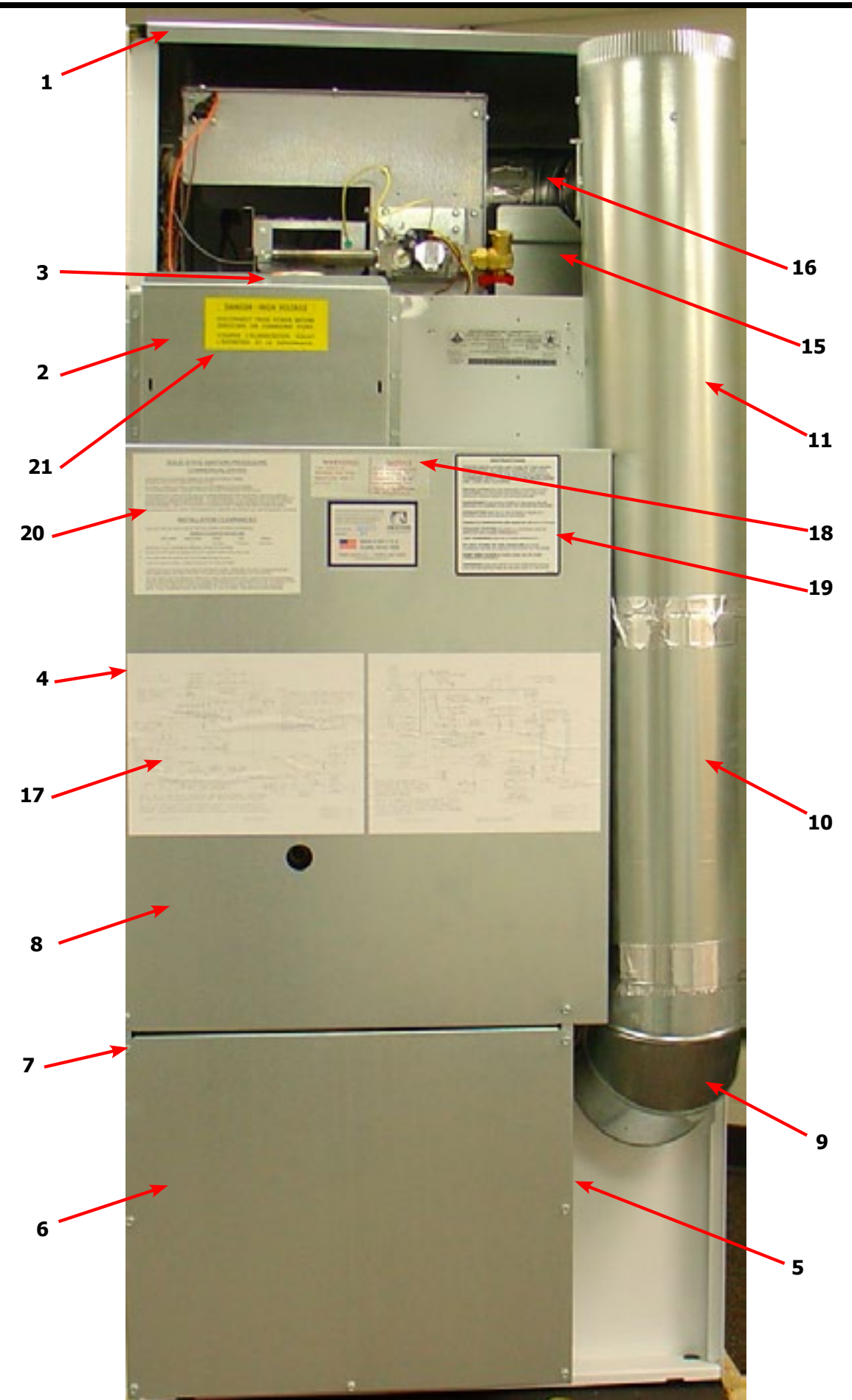
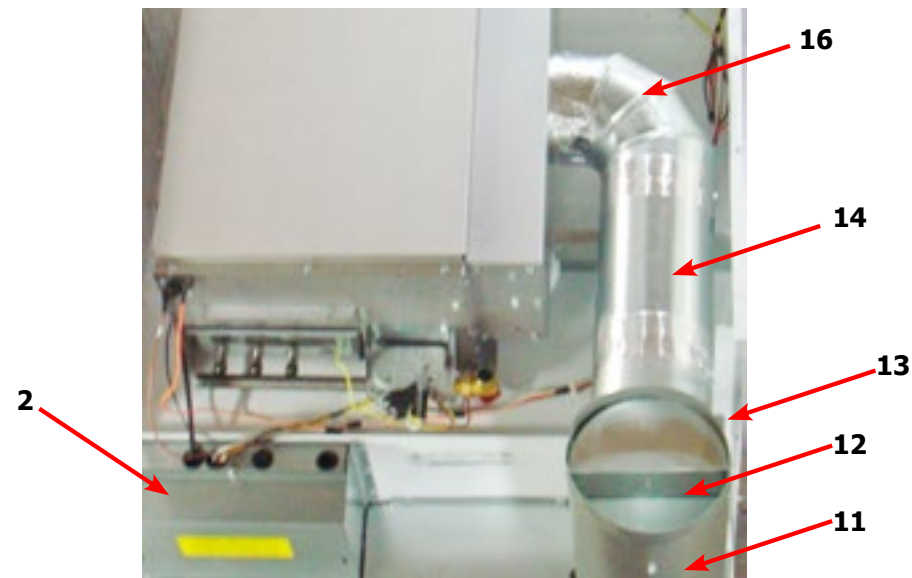

Dryer Rear View-Bearing Housing 30Lb

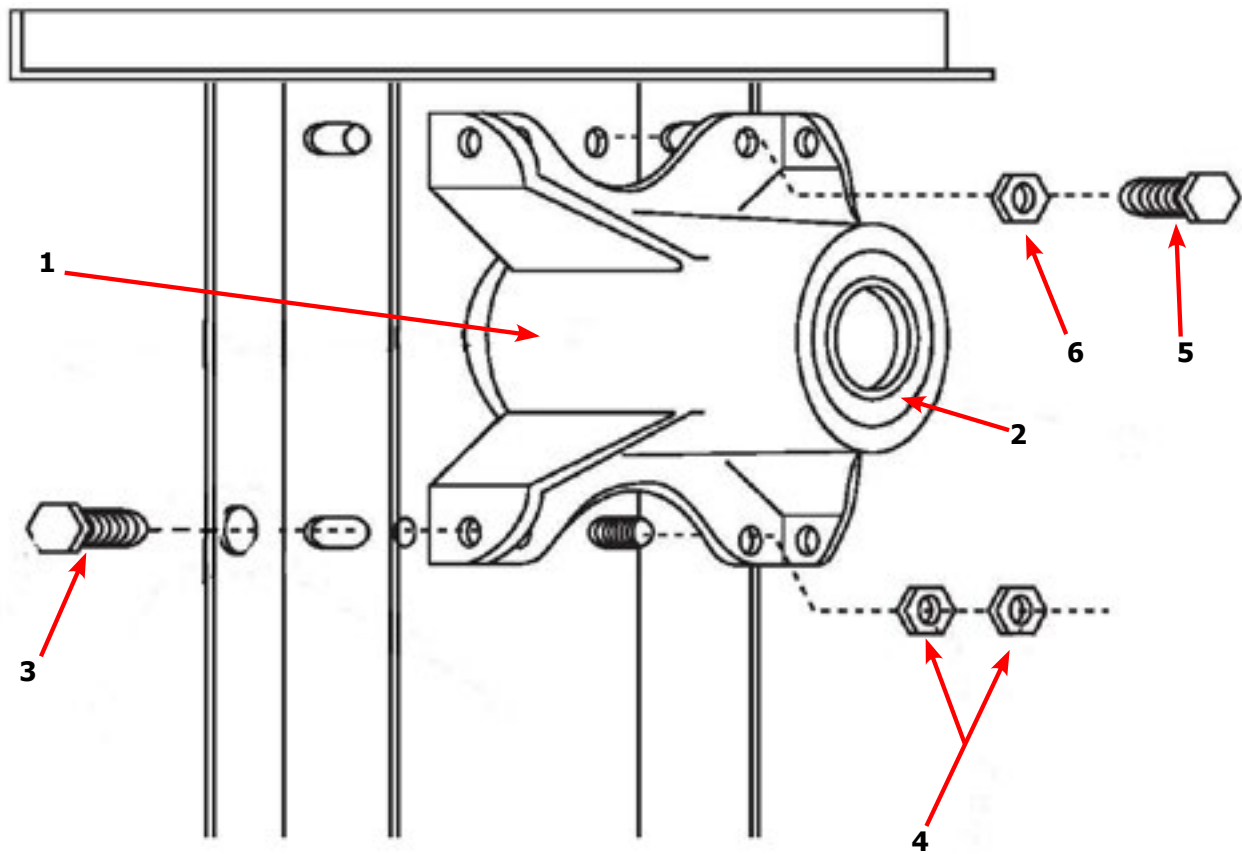

Key	Description	T-30	QTY
*	Bearing Housing Complete Assy. (Includes bearings & Spacer)	9803-160-003	1
1	Housing, Bearing	9241-161-002	1
*	Bearing, Ball, Front	9036-130-001	1
*	Spacer, Bearing	9538-139-002	1
2	Bearing, Ball, Rear	9036-130-001	1
3	Screw-Wizlock, 3/8-24x3/4	9545-049-002	4
4	Nut, 5/16-18	8640-400-002	4
5	Screw, 3/8-24x1	9545-049-001	2
6	Nut, 3/8-24	8640-415-002	2
*	Shim, Tumbler	9538-139-002	AR

↓ Scroll down for
50lb and 80lb
Parts Breakdown

Dryer Tumbler Group 30Lb

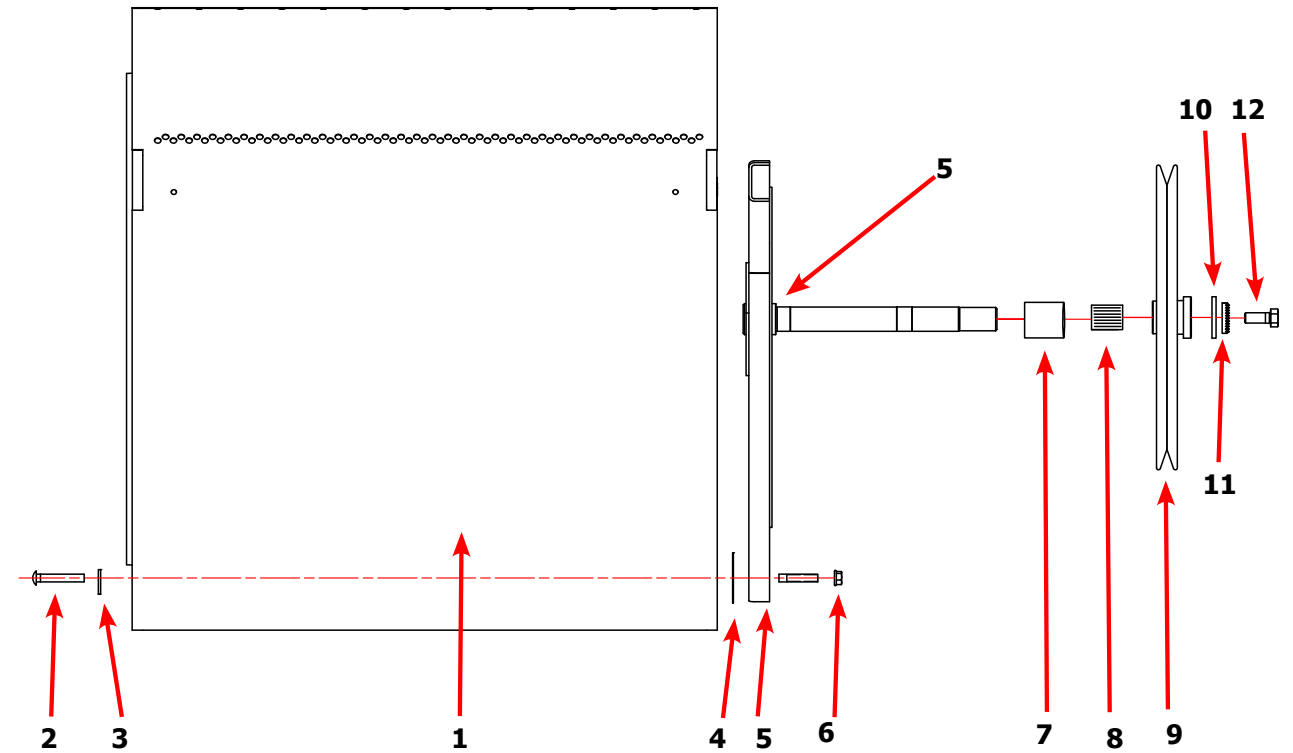

Key	Description	T-30	QTY
*	Tumbler Assy. Complete W/ Spider (GALV)	9848-147-001	1
1	Tumbler Assy. (Galvanized)	9848-146-001	1
*	Tumbler Assy. Complete w/ Spider (SS)	9848-147-002	1
*	Tumbler Assy (SS)	9848-147-001	1
2	Rod, Tumbler	9497-226-003	3
3	Washer, Special	8641-554-001	3
4	Shim	9552-013-003	AR
5	Spider Assy.	9568-015-001	1
6	Nut, Wiz Lock	8640-415-004	3
7	Spacer-Shaft	9538-164-001	1
8	Tolerance Ring	9487-234-005	1
9	Pulley, Driven	9908-049-002	1
10	Washer -Flat	8641-581-026	1
11	Lock Washer - IntTooth, 1"	8641-582-016	1
12	Screw, 1/2-13x1 1/4	9545-017-009	1

↓ Scroll down for
50lb and 80lb
Parts Breakdown

Dryer Rear View-Bearing Housing 50Lb

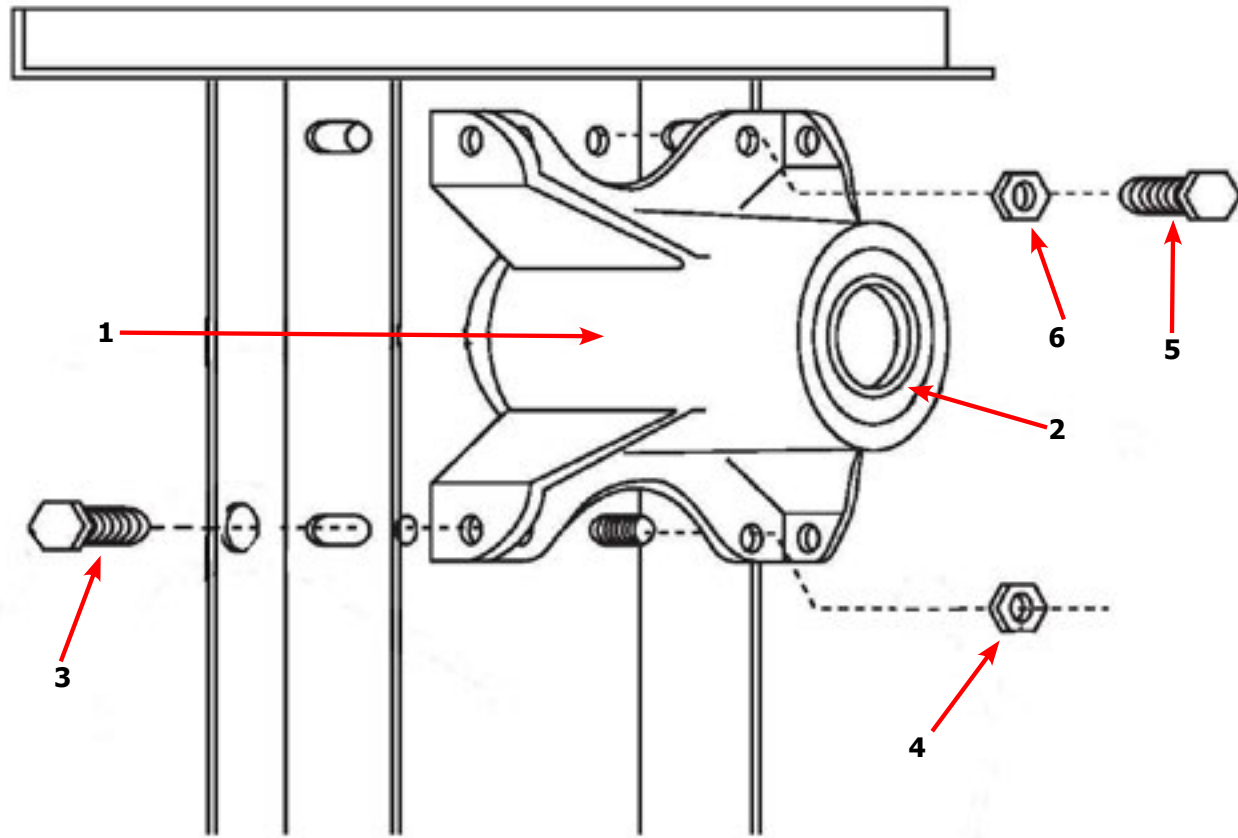

Key	Description	T-50	QTY
	Bearing Housing Complete Assy. (Includes bearings & Spacer)	9803-201-001	1
1	Housing, Bearing	9241-189-002	1
*	Bearing, Ball, Front	9036-159-001	1
*	Spacer, Bearing	9538-183-001	1
2	Bearing, Ball, Rear	9036-159-003	1
3	Screw-Wizlock, 1/2-13x3/4	9545-017-017	4
4	Nut, 1/2-13	8640-417-002	2
5	Screw, 1/2-13x1 1/2	9545-017-018	2
6	Nut, 1/2-13	8640-417-002	2

↓ Scroll down for
80lb Parts
Breakdown

Dryer Tumbler Group 50Lb

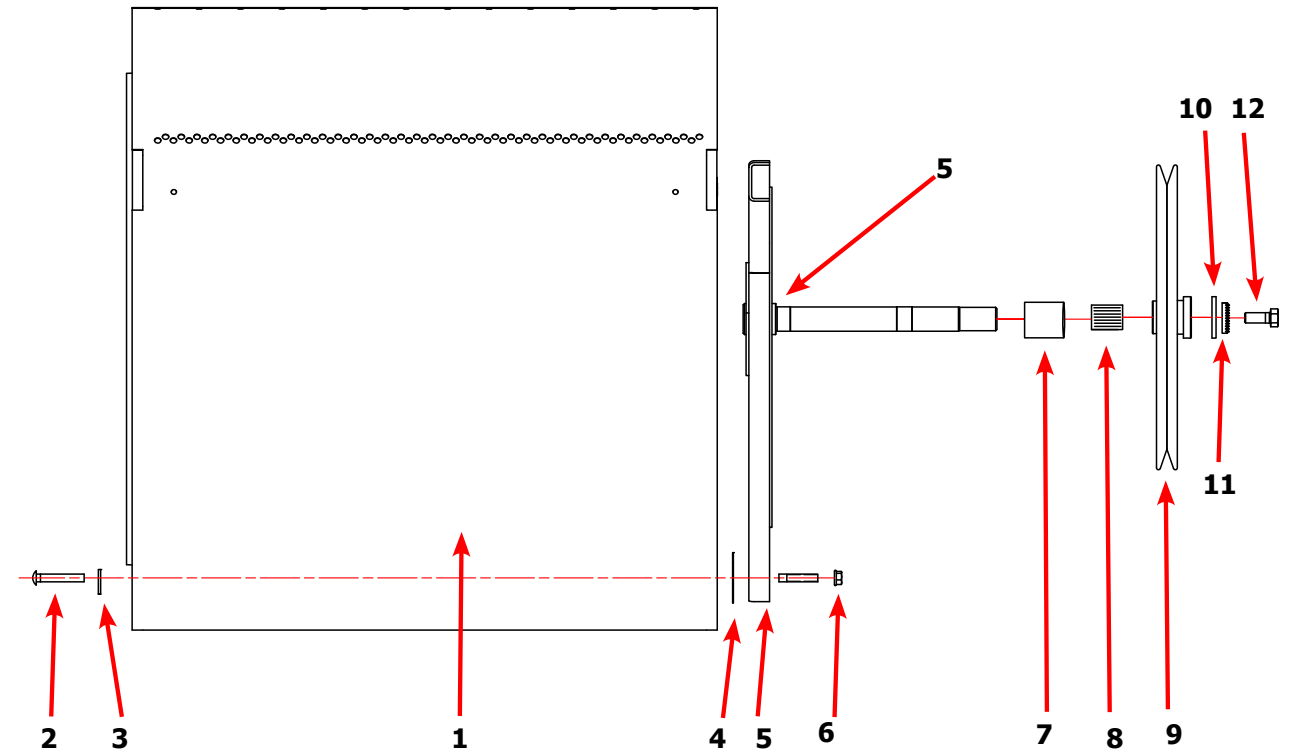

Key	Description	T-50	QTY
*	Tumbler Assy. Complete W/ Spider (GALV)	9848-149-001	1
1	Tumbler Assy. (Galvanized)	9848-148-001	1
*	Tumbler Assy. Complete W/ Spider (SS & Galv front)	9848-149-002	1
1	Tumbler Assy. (Stainless Galvanized front)	9848-148-002	1
2	Rod, Tumbler	9497-226-002	3
3	Washer, Special	8641-590-002	3
4	Shim	9552-013-000	AR
5	Spider Assy.	9568-013-001	1
6	Nut, Wiz Lock	8640-417-005	3
7	Spacer-Shaft	9538-184-001	1
8	Tolerance Ring	9487-234-005	1
9	Pulley, Driven	9908-047-002	1
10	Washer -Flat	8641-581-026	1
11	LockWasher - IntTooth, 1"	8641-582-016	1
12	Screw, 1/2-13x1 1/4	9545-017-009	1

↓ Scroll down for
80lb Parts
Breakdown

Dryer Rear View-Bearing Housing 80Lb

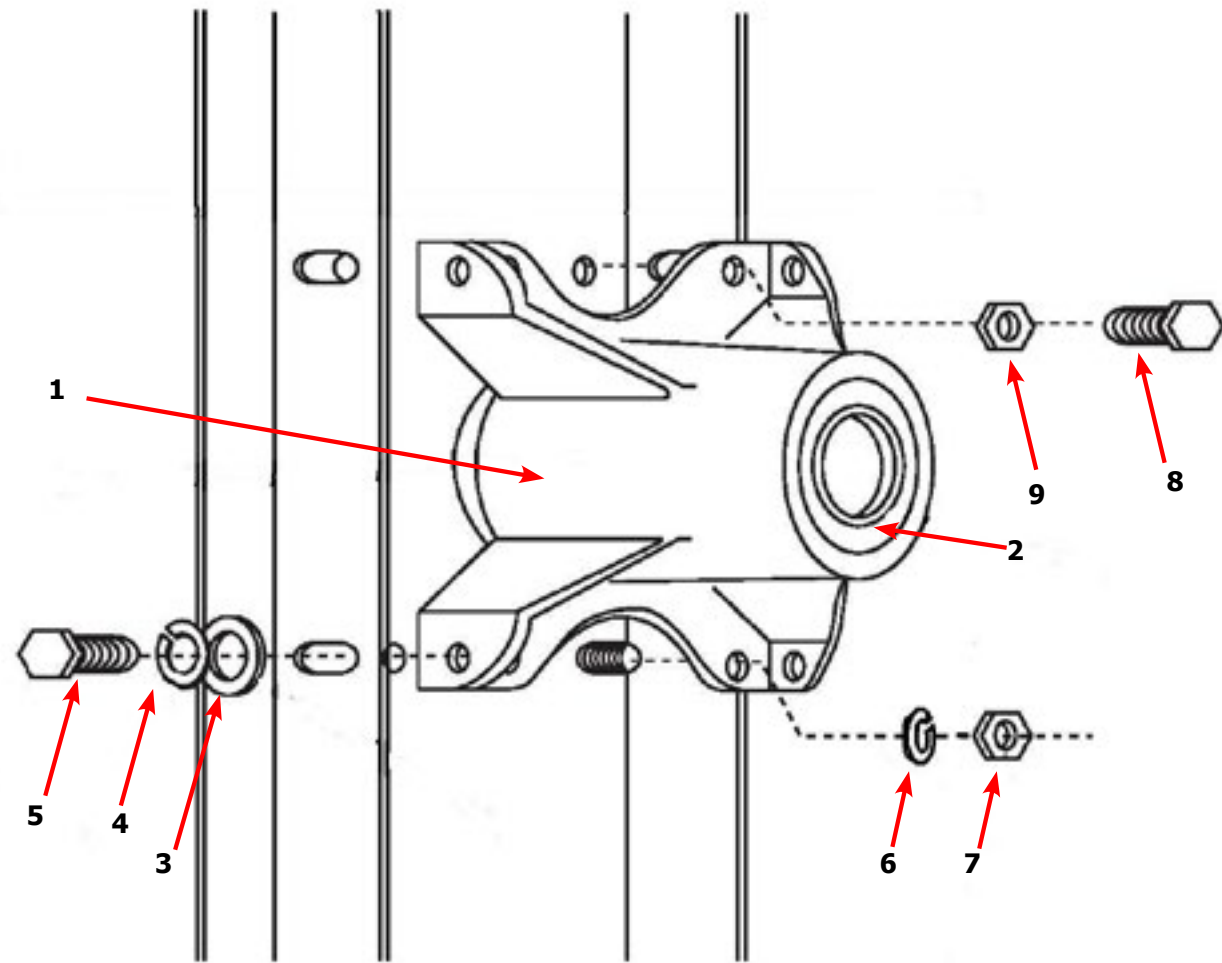

Key	Description	T-80	QTY
	Bearing Housing Complete Assy. (Includes bearings & Spacer)	9803-189-001	
1	Housing, Bearing	9241-183-003	
*	Bearing, Ball, Front	9036-159-002	
*	Spacer, Bearing		
2	Bearing, Ball, Rear	9036-159-001	
3	Washer, Flat 1/2	8641-581-026	
4	Lock Washer Spring, 1/2	8641-582-004	
5	Screw, 1/2-13x1	9545-017-004	
6	Lock Washer Spring, 1/2	8641-582-004	
7	Nut, 7/16-14	8640-416-001	
8	Screw, 7/16-14x1 1/2	9545-059-003	
9	Nut, 7/16-14	8641-416-001	

Dryer Tumbler Group 80Lb

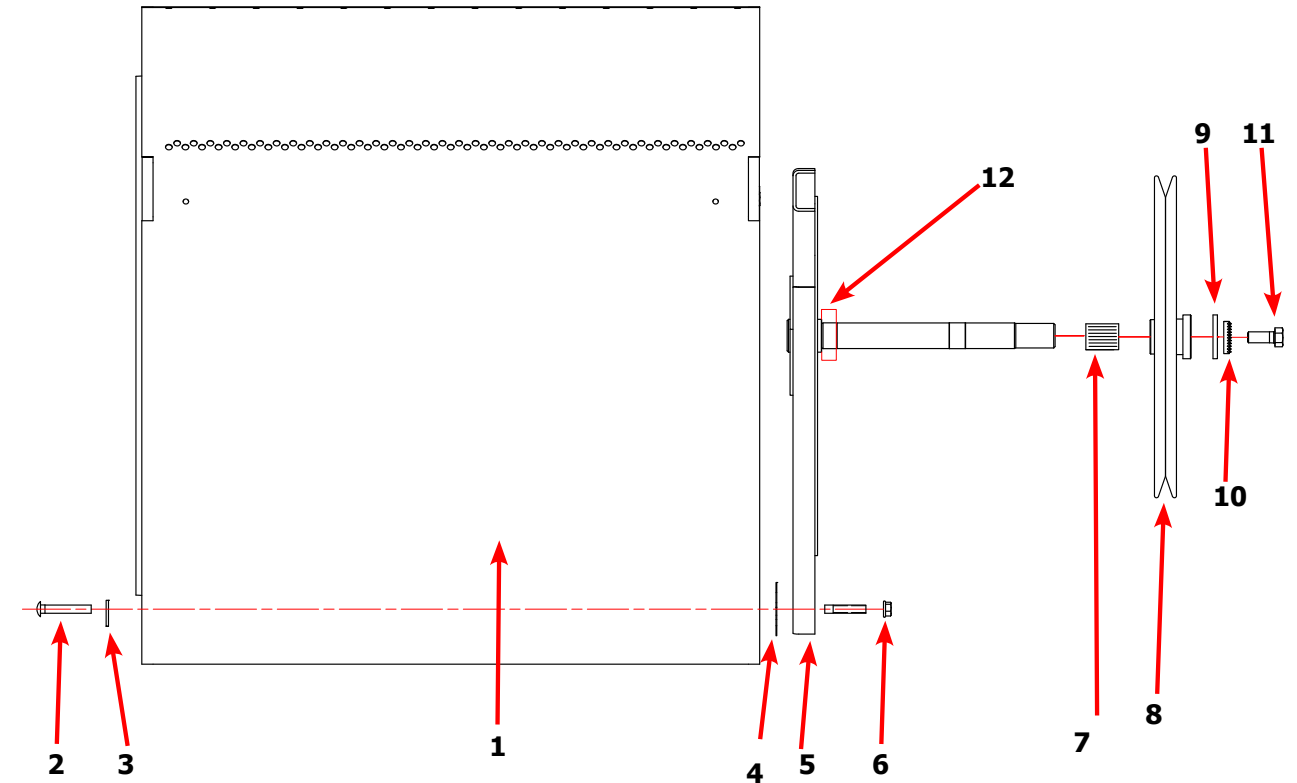

Key	Description	T-80	QTY
*	Tumbler Assy. Complete W/ Spider (GALV)	9848-151-001	1
1	Tumbler Assy. (Galvanized)	9848-150-001	1
1	Tumbler Assy. Complete W/ Spider (SS & Galv front)	9848-151-002	1
1	Tumbler Assy. (Stainless Galvanized front)	9848-150-002	1
2	Rod, Tumbler	9497-266-001	4
3	Washer, Special	8641-590-001	4
4	Shim	9552-013-000	AR
5	Spider Assy. w/ Front Bearing	9873-008-001	1
6	Nut, Wiz Lock	8640-417-005	4
7	Tolerance Ring	9487-234-001	1
8	Pulley, Driven	9908-043-002	1
9	Washer -Flat	8641-581-026	1
10	LockWasher - IntTooth, 1"	8641-582-016	1
11	Screw, 1/2-13x1 1/4	9545-017-009	1
12	Bearing, Front	9036-159-002	1

Dryer Burner Housing Group 30Lb

Key	Description	Part Number	Qty
*	Housing Assembly, Burner	9803-210-001	1
1	Panel-Burner Housing, Side Left	9454-845-001	1
2	Baffle-Burner Housing, Center	9049-091-001	1
3	Panel-Burner Housing, Top	9454-871-001	1
4	Panel-Burner Housing, Front	9454-847-001	1
5	Panel-Burner Housing, Back	9454-848-001	1
6	Baffle-Burner Housing, Recirculation	9049-092-001	1
7	Baffle-Burner Housing, Front	9049-093-001	1
8	Duct Adaptor, 6"x 3" long	9109-120-01	1
9	Burner, Main	9048-021-001	2
10	Bracket-Support, Electrode	9029-214-001	1
11	Bracket-Support, Gas Valve	9029-227-001	1
12	Electrode-Ignition	9875-002-003	1
13	Control Assy, Gas Valve, White Rodgers 36J	9857-192-001	1
14	Manifold Assy.	9381-009-007	1
15	Valve-Gas Shutoff (Optional)	9379-196-001	1
16	Thermostat-HI-Limit	9576-203-002	1
17	Screw, 10ABx3/8	9545-008-024	24
18	Screw, 10ABx1/4	9545-008-006	17
19	Orifice-Natural, .125	9425-069-023	2
*	Orifice-LP, #48	9425-069-003	2
*	Kit, LP Conversion, White Rodgers	9732-102-018	1
20	Bracket-Support, Burner	9029-225-001	1
21	Panel-Burner Housing, Side Right	9454-861-001	1
22	Screw, 10-32TTx1/2 Green	9545-008-027	3
23	Screw, 8-32x3/8	9545-010-014	4

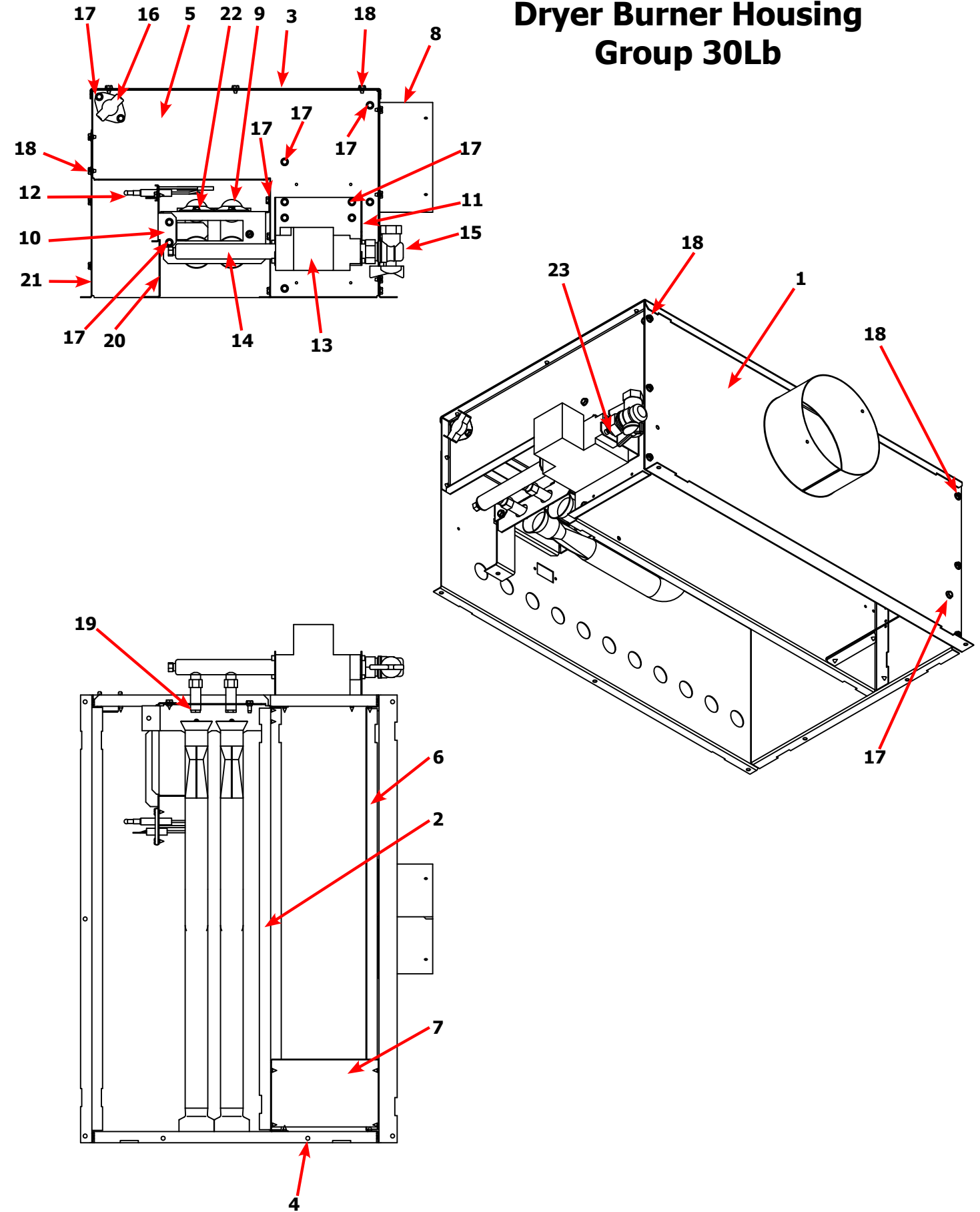



**Scroll down for
50lb and 80lb
Parts Breakdown**

Dryer Burner Housing Group 80Lb

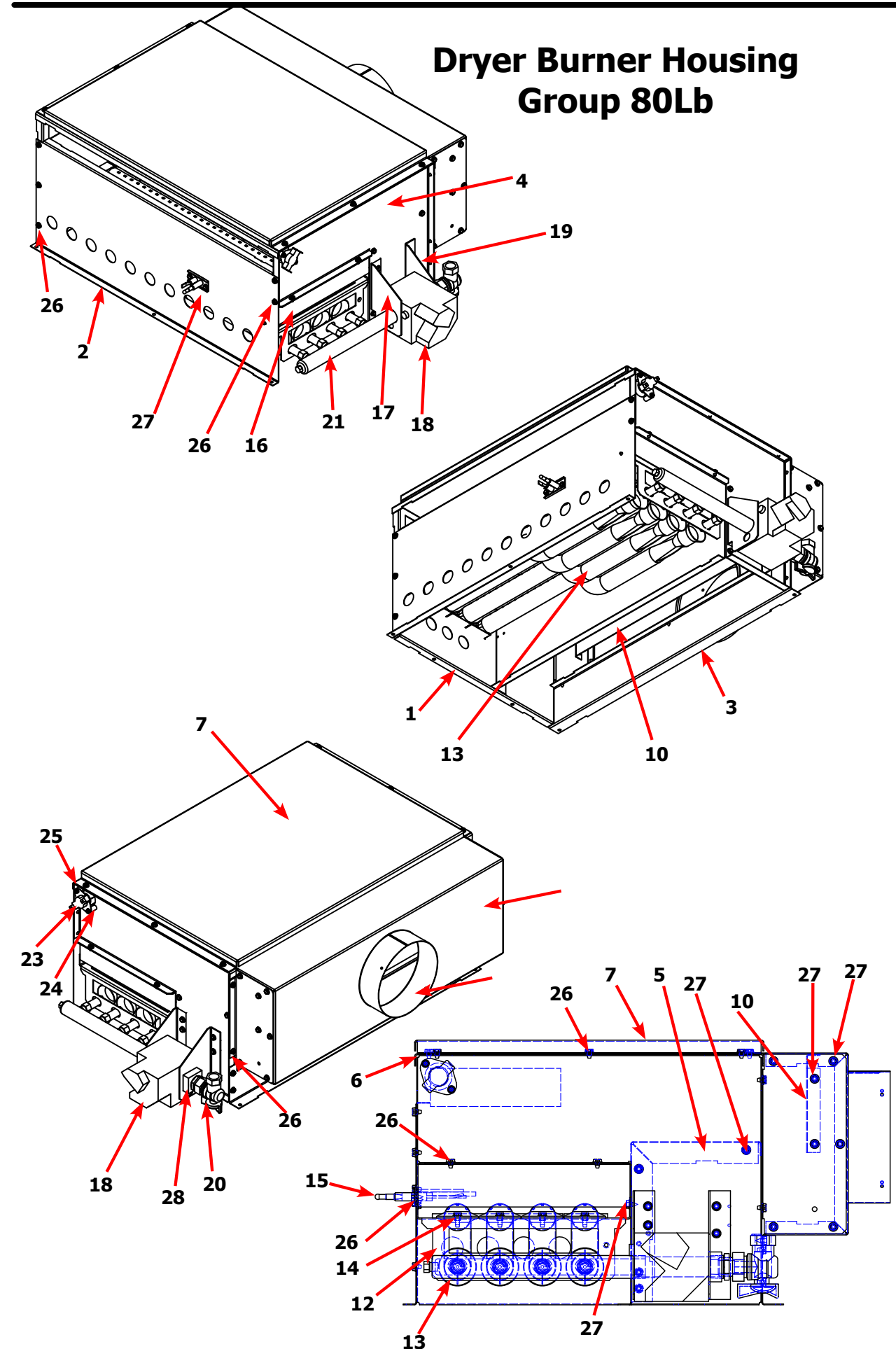
Key	Description	Part Number	Qty
	Housing Assembly, Burner	9803-212-001	1
1	Panel-Burner Housing, Front	9454-863-001	1
2	Panel-Burner Housing, Side Right	9454-861-001	1
3	Panel-Burner Housing, Side Left	9454-862-001	1
4	Panel-Burner Housing, Back	9454-864-001	1
5	Baffle-Burner Housing, Center	9049-098-001	1
6	Panel-Burner Housing, Top	9454-849-001	1
7	Panel-Burner Housing, Top	9074-343-001	1
8	Baffle-Burner Housing, Extension	9049-100-001	1
9	Duct Adaptor, 6"x1.25" long	9109-120-002	1
10	Baffle-Burner Housing, Recirculation	9049-099-001	1
11	Side-Extension Baffle, Burner Housing	9551-049-001	2
12	Bracket-Support, Burner	9029-213-001	1
13	Burner, Main	9048-021-001	4
14	Screw, 10T-32x1/2	9545-008-008	4
15	Electrode-Ignition	9875-002-003	1
16	Cover-Burner, Inlet	9074-344-001	1
17	Bracket-Support, Gas Valve	9029-234-001	1
18	Control Assy. Gas Valve, White Rodgers 36J	9857-193-001	1
19	Bracket-support, Gas Valve Left hand	9029-235-001	4
20	Valve-Gas Shutoff, (Optional)	9379-196-001	1
21	Manifold Assy.	9381-014-001	1
22	Orifice-Natural, #29	9425-069-021	3
*	Orifice-LP, #46	9425-069-022	3
*	Kit, LP Conversion, White Rodgers	9732-102-023	1
23	Thermostat-HI-Limit	9576-203-002	1
24	Spacer-1/4x5/8 long	9538-166-009	2
25	Screw-8Bx1	9545-045-013	2
26	Screw, 10Bx1/4	9545-008-001	22
27	Screw, 10ABx3/8	9545-008-024	31
28	Bushing-Reducer, 3/4x1/2	8615-104-009	1

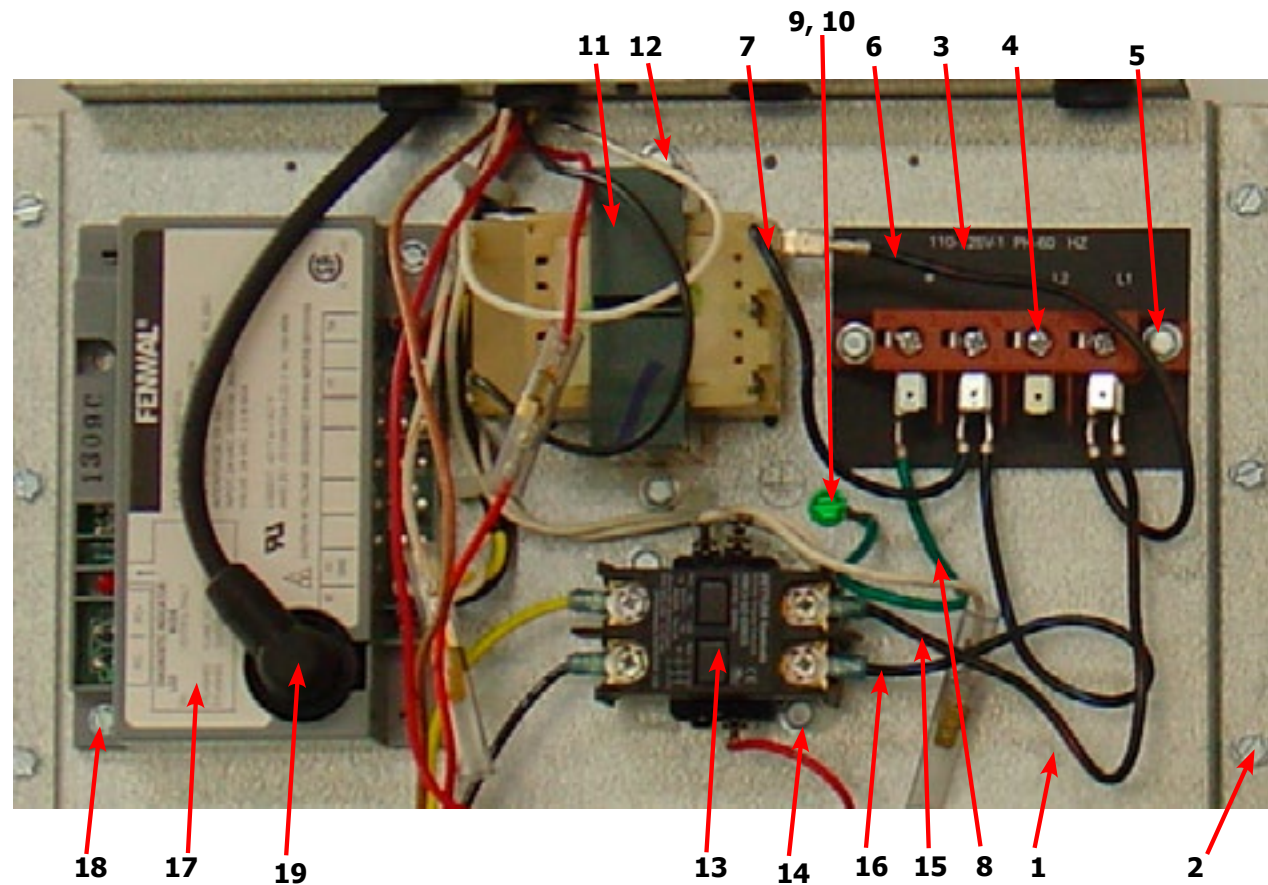

Electrical Box / Ignition Control



Key	Description	T-30	T-50	T-80	QTY
1	Wrapper-Control Box	9636-200-001	9636-200-001	9636-200-001	1
2	Screw, 5/16-10AB-3/8	9545-008-001	9545-008-001	9545-008-001	6
*	Cover-Control Box	9074-346-001	9074-346-001	9074-346-001	1
*	Screw, 5/16-10AB-3/8	9545-008-024	9545-008-024	9545-008-024	1
3	Strip-Marker, Terminal	9558-029-005	9558-029-005	9558-029-005	1
4	Terminal Block Assy-Power, 4Pole	9897-035-001	9897-035-001	9897-035-001	1
5	Screw, 5/16-10AB-3/8	9545-008-024	9545-008-024	9545-008-024	2
6	Wire assy-Blk/Red, 6 1/2"	8220-001-230	8220-001-230	8220-001-230	1
7	Wire assy-Blk/Blu, 6 1/2"	8220-001-231	8220-001-231	8220-001-231	1
8	Wire Assy, GRN, 7"	8220-001-478	8220-001-478	8220-001-478	1
9	Screw- 10-32Tx1/2 GRN	9545-008-027	9545-008-027	9545-008-027	1
10	Lockwasher, External tooth	8641-582-006	8641-582-006	8641-582-006	1
11	Transformer, w/Circuit breaker	8711-007-002	8711-007-002	8711-007-002	1
12	Screw, 5/16-10AB-3/8	9545-008-024	9545-008-024	9545-008-024	2
13	Relay-Motor, 30Amp, 24VAC	5192-299-002	5192-299-002	5192-299-002	1
14	Screw, 5/16-10AB-3/8	9545-008-024	9545-008-024	9545-008-024	2
15	Wire assy-Blk/Red, 9"	8220-146-001	8220-146-001	8220-146-001	1
16	Wire assy-Blk/Blu, 9"	8220-146-002	8220-146-002	8220-146-002	1
17	Control Assy, Ignition (Module)	9857-182-001	9857-182-001	9857-182-001	1
18	Screw-8Bx3/4"	9545-045-007	9545-045-007	9545-045-007	2
*	Harness, Ignition Module	9627-867-003	9627-867-003	9627-867-003	1
19	Wire Assy- High Voltage Lead	9631-403-009	9631-403-009	9631-403-009	1

Airflow Switch Assembly

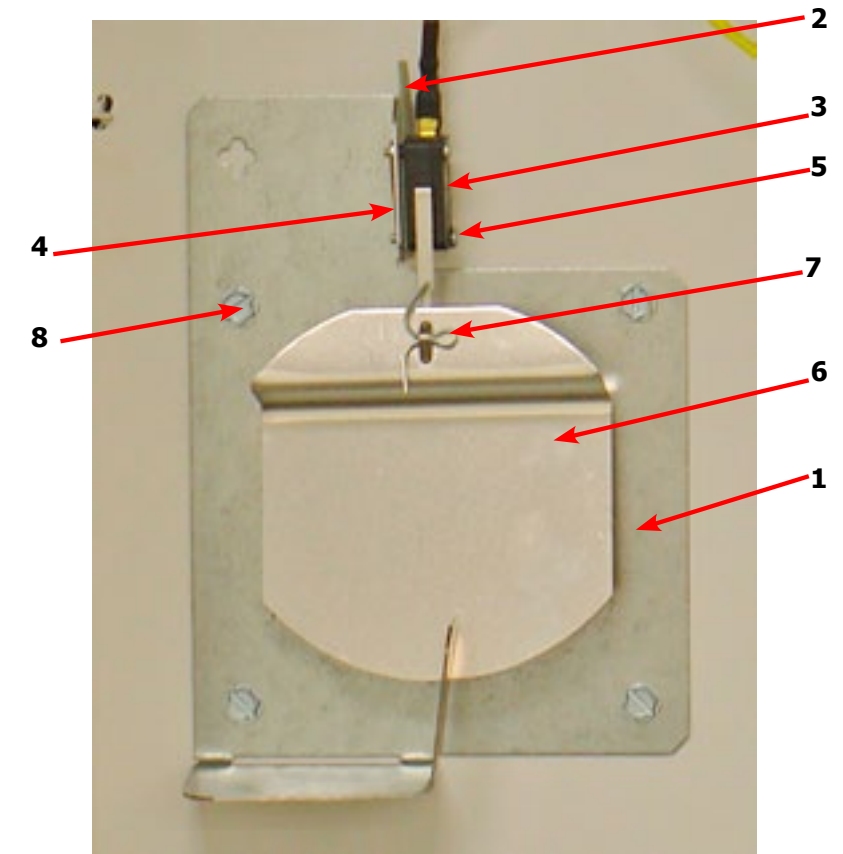

Key	Description	T-30	T-50	T-80	QTY
*	Air Flow switch Assy.	9801-095-001	9801-098-001	9801-098-001	1
1	Bracket-Airflow switch	9029-174-001	9029-200-001	9029-200-001	1
2	Shield-Switch	9550-169-003	9550-169-003	9550-169-003	1
3	Switch-Micro	9539-461-009	9539-461-009	9539-461-009	1
4	Nut-Twin, 4-40	8640-401-001	8640-401-001	8640-401-001	1
5	Screw-.625, 4-40	9545-020-001	9545-020-001	9545-020-001	2
6	Actuator-Air Flow Switch	9008-007-001	9008-007-001	9008-007-001	1
7	Pin-Cotter, .09375x.75	9451-169-002	9451-169-002	9451-169-002	1
	Screw, 10Bx1/4	9545-008-001			3
	Screw, 10Bx1/4		9545-008-001	9545-008-001	4

Wiring Schematic for 60hz Dryer -10

9506-546-001PR

SCHEMATIC

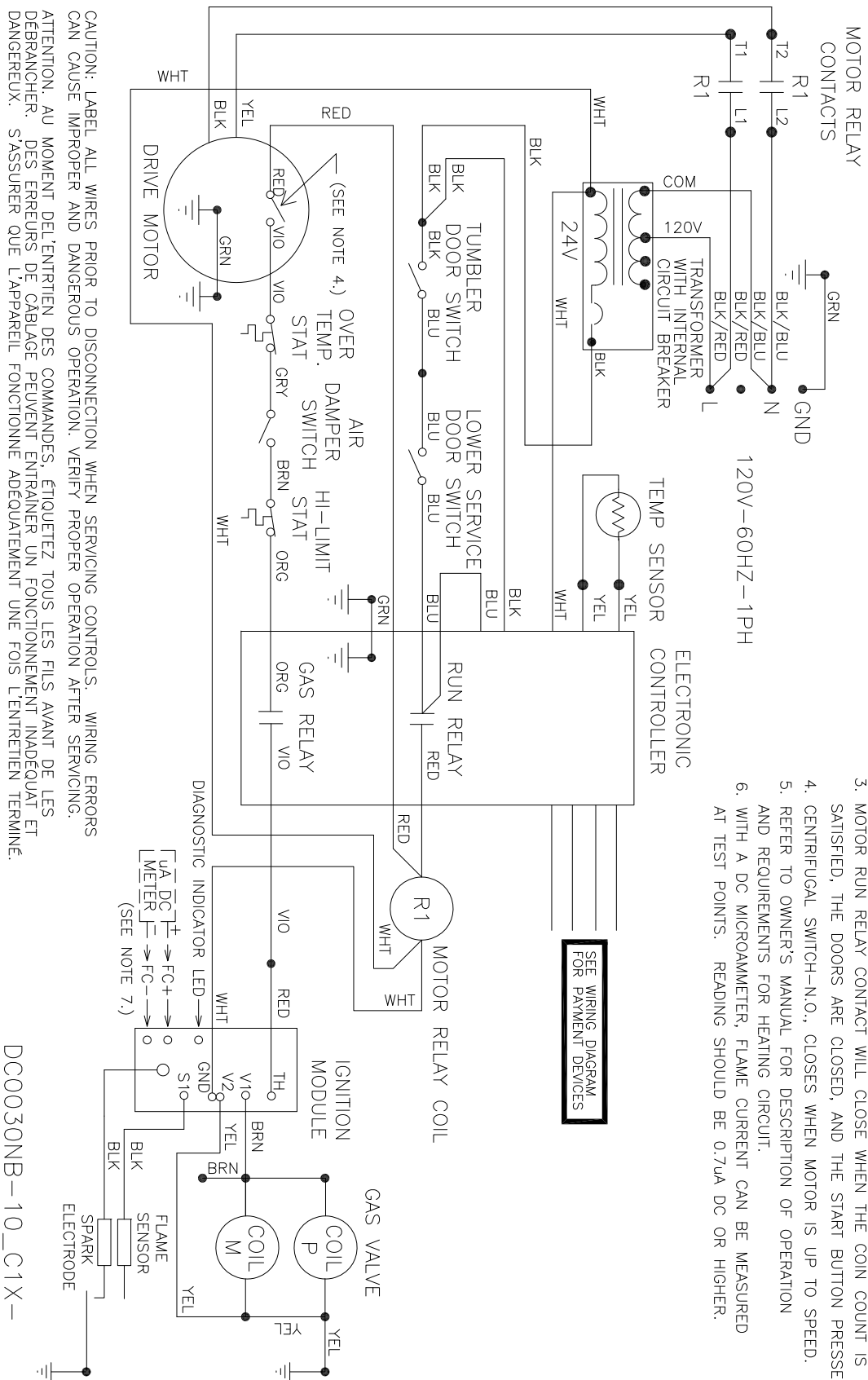

NOTES:

1. COIN SWITCH-N.O., CLOSES WHEN COIN IS INSERTED (SEE SHEET 2).
2. DOOR SWITCHES-N.O., CLOSED WHEN DOORS ARE CLOSED.
3. MOTOR RUN RELAY CONTACT WILL CLOSE WHEN THE COIN COUNT IS SATISFIED, THE DOORS ARE CLOSED, AND THE START BUTTON PRESSED.
4. CENTRIFUGAL SWITCH-N.O., CLOSES WHEN MOTOR IS UP TO SPEED.
5. REFER TO OWNER'S MANUAL FOR DESCRIPTION OF OPERATION AND REQUIREMENTS FOR HEATING CIRCUIT.
6. WITH A DC MICROAMMETER, FLAME CURRENT CAN BE MEASURED AT TEST POINTS. READING SHOULD BE 0.7uA DC OR HIGHER.

Wiring Diagram for 60hz Dryer -10

9506-546-001PR

WIRING DIAGRAM

DC0030NB-10_C1X-
DC0050NB-10_C1X-
DC0080NB-10_C1X-

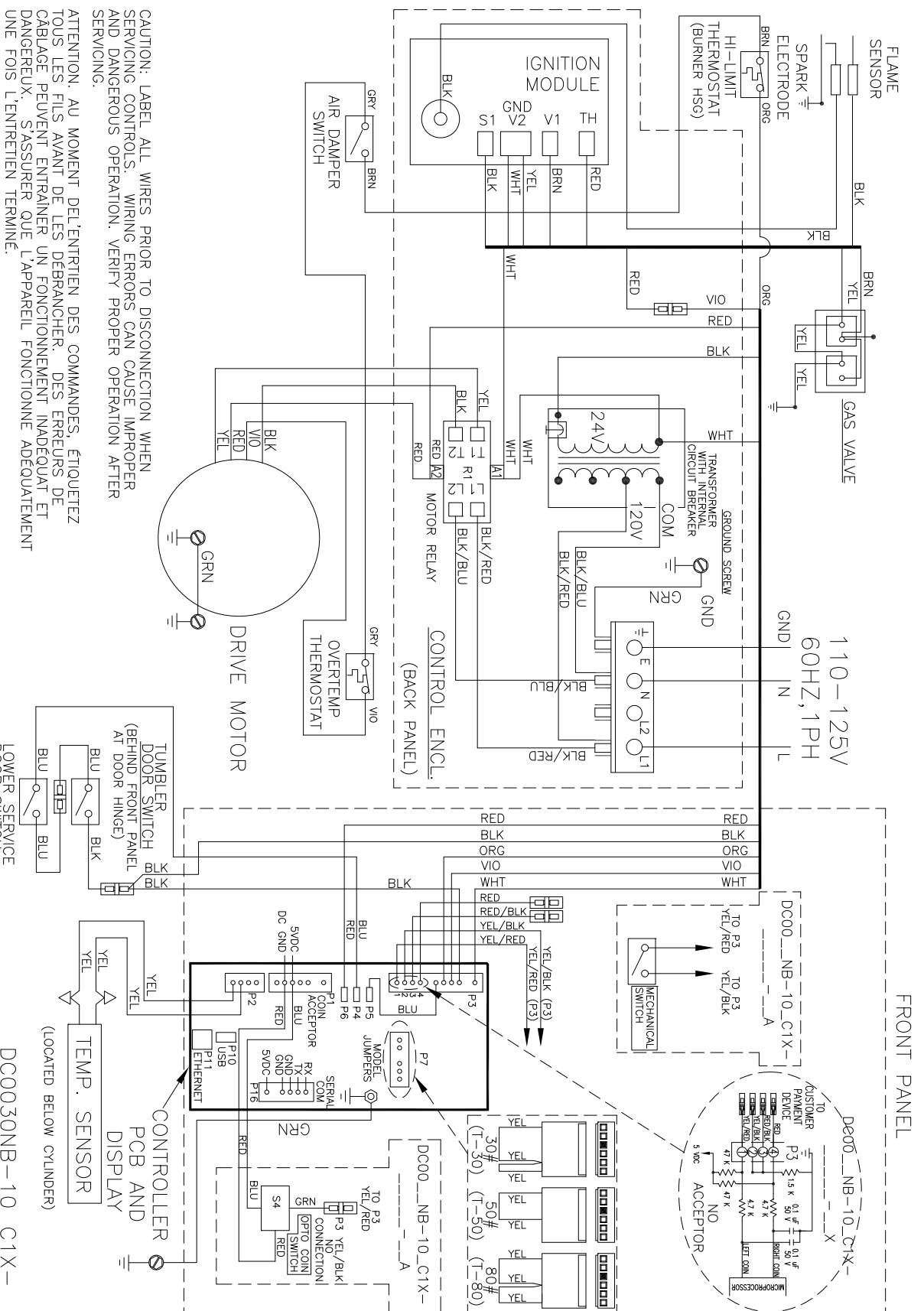

30 lb. Commercial Dryer: T-30 – DC0030NB-10EC1X (60 Hz), DC0030NB-39AC1X (50 Hz)

Cabinet Height	72 1/4"	1835 mm.
(Assumes minimum leveling leg adjustment)		
Cabinet Width	31 1/2"	800 mm.
Overall Depth	42"	1067 mm.
Floor to Door Center	41 1/4"	1048 mm.
Door Opening	22 5/8"	575 mm.
Dry Wt. Capacity	30 lbs.	13.6 kg.
Cylinder Diameter	30"	762 mm.
Cylinder Depth	27 1/2"	699 mm.
Cylinder Volume	11.25 cu. ft.	319 liters
Lint Screen Area	515 sq. in.	3323 sq. cm.
Gas Input (60 hz)	90,000 Btu/hr	26.4 kW
Gas Input (50 hz)	72,000 Btu/hr	21.1 kW
Gas Supply Connection	1/2"	12.7 mm.
Natural Gas Supply (Water Column)	5-10"	127 mm. - 254 mm.
Natural Burner Manifold	3 1/2"	88.9 mm.
L.P. Supply (Water Column)	11 1/2 -14"	292 mm. - 356 mm.
L.P. Burner Manifold	11"	279 mm.
Exhaust Size	8"	203 mm.
Make-up Air	1.0 sq. ft.	929 sq. cm.
Example: 1.0 sq. ft = 1 ft. long X 1 ft. wide		
Motor Size	1/2 H.P.	.373 kW
Airflow (60 hz)	830 CFM	23.5 m ³ /min
Airflow (50 hz)	690 CFM	19.5 m ³ /min

Electrical Specifications - 220-240/50/1

Voltage/Hz/Phase	220-240V/50Hz/1Phase	
Running Amps	5.1	
Circuit Protection Amps	10	
Wire Size	14 gauge	
Electrical Service	2 wire + ground	

Shipping Weight	507 lbs.	231 kg.
Net Weight	463 lbs. 210 kg.	
Clearance Behind Machines (min.)	18"	457 mm.

Parts Section-39 & -59 230VAC 1 PH 50Hz

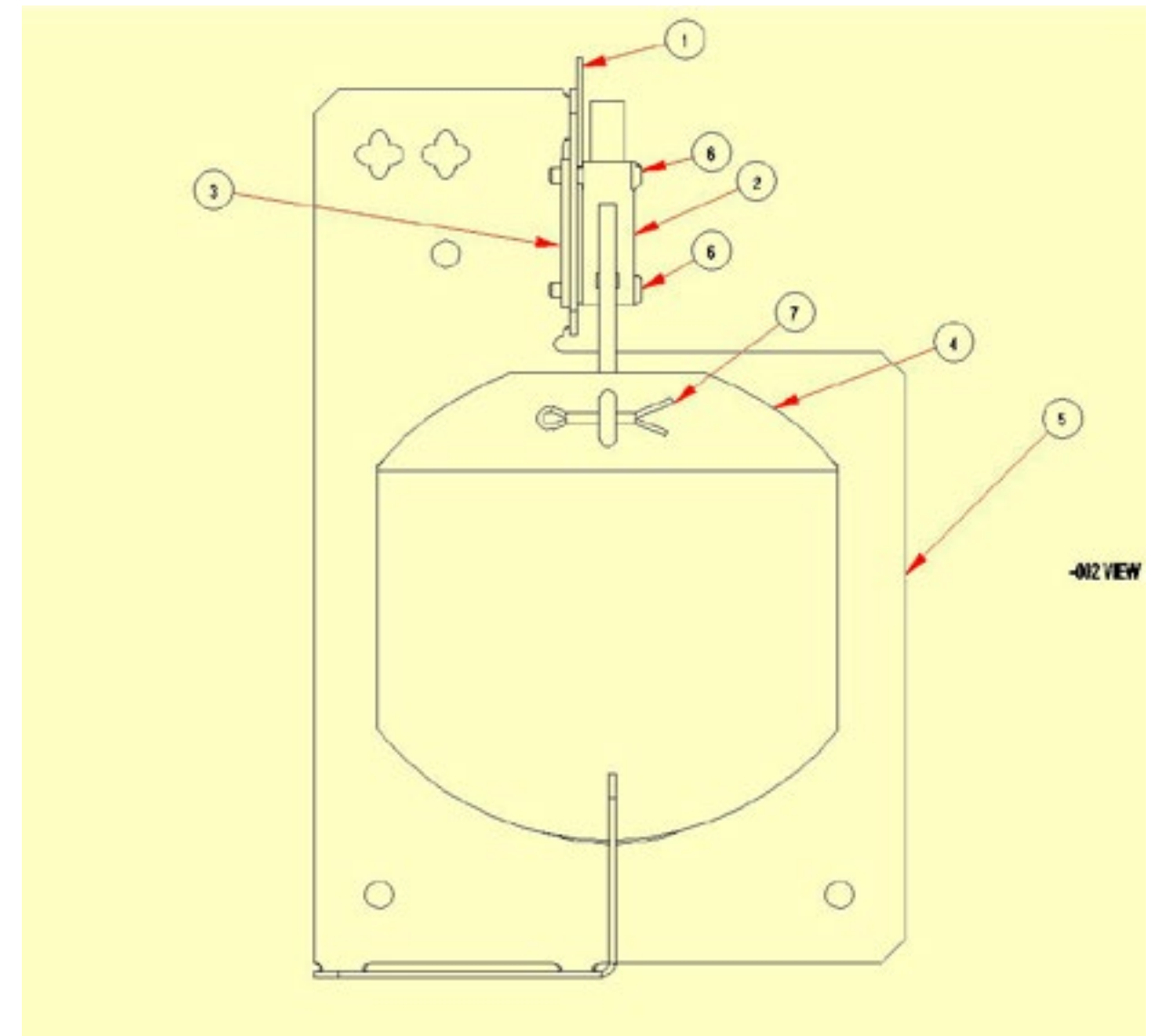

Key	Description	T-30	T-50	T80	QTY
	Switch Assembly-Air flow (1-7)	9801-095-002	9801-098-002	9801-098-002	1
1	Shield - Switch	9550-169-003	9550-169-003	9550-169-003	1
2	Switch Micro	9539-461-009	9539-461-009	9539-461-009	1
3	Nut - Twin, 4-40	8640-401-001	8640-401-001	8640-401-001	1
4	Actuator-Switch, Air-Flow	9008-007-001	9008-007-001	9008-007-001	1
5	Bracket-Airflow switch	9029-174-002	9029-200-002	9029-200-002	1
6	Screw-PNHDSL, 4-40, UNC x 0.625	9545-020-001	9545-020-001	9545-020-001	2
7	Pin-Cotter, 0.09375 x 0.75	9451-169-002	9451-169-002	9451-169-002	1

Parts for 50hz Dryer -39

Key	Description	T-30	T-50	T80	QTY
*	Motor, Marathon 50Hz	9376-311-004	9376-317-004	9376-317-004	1
*	Pulley, Motor	9453-169-009	9453-169-014	9435-169-009	1
*	Strip Terminal Marker	9558-029-004	9558-029-004	9558-029-004	1
*	Wiring Label-Schematic/Diagram	9506-496-001	9506-496-001	9506-496-001	1
*	Orifice Main Burner, #32 Natural	9425-069-009	N.A.	N.A	2
*	Orifice Main Burner, #32 Natural	N.A.	9425-069-009	N.A	3
*	Orifice Main Burner, #30 Natural	N.A.	N.A.	9425-069-002	4
*	LP Kit	9732-102-019	9732-102-021	9732-102-022	1
*	Overlay-Trim Lower door	9435-016-004	9435-016-005	9435-016-006	1
*	Label Warning	8502-698-001	8502-698-001	8502-698-001	1

Parts for 50hz Dryer -59

Key	Description	T-30	T-50	T80	QTY
*	Strip Terminal Marker	9558-029-004	9558-029-004	9558-029-004	1
*	Filter, EMI Line	9183-030-001	9183-030-001	9183-030-001	1
*	Transformer, Control (Before Serial)	8711-008-002	8711-008-002	8711-008-002	1
*	Transformer (After Serial)	8711-004-004	8711-004-004	8711-004-004	1
*	Holder, Fuse	9054-045-001	9045-045-001	9045-045-001	1
*	Fuse 2.5 Amp	8636-018-004	8636-018-004	8636-018-004	1
*	Motor, Marathon 50Hz	9376-311-004	9376-317-004	9376-317-004	1
*	Pulley, Motor	9453-169-009	9453-169-014	9453-169-009	1
*	Wiring Label-Schematic/Diagram (Before serial)	9506-644-001	9506-644-001	9506-644-001	1
*	Wiring Label (After Serial #)	9506-964-001	9506-964-001	9506-964-001	1
*	Orifice Main Burner, #30 Natural	9425-069-009	9425-069-009	9425-069-002	4
*	LP Kit	TBR	TBR	TBR	1
*	Gas Valve Assembly	9857-132-004	9857-132-004	9857-132-004	1
*	Kit-Honeywell VR86 Flange Kit 3/4	9732-162-002	9732-162-002	9732-162-002	2
*	Adaptor Assembly Gas Valve	9791-001-001	9791-001-001	9791-001-001	1
*	Manual, Operators (Before Serial #)	8514-234-002	8514-234-002	8514-234-002	1
*	Manual, Operators (After Serial #)	8514-309-001	8514-309-001	8514-309-001	1
*	Hot Surface Warning Label	8502-748-017	8502-748-017	8502-748-017	1
*	Do Not Enter Warning Label	8502-748-001	8502-748-001	8502-748-001	1
*	Explosive Material Warning Label	8502-748-006	8502-748-006	8502-748-006	1
*	Flammable Material Warning Label	8502-748-007	8502-748-007	8502-748-007	1
*	Do Not Operate w/ Guards Removed Label	8502-748-003	8502-748-003	8502-748-003	3
*	Frame/Chassis Ground Label	8502-748-014	8502-748-014	8502-748-014	1
*	Do Not Operate w/ Guards Removed Label	8502-748-004	8502-748-004	8502-748-004	1
*	Electrical Shock Warning Label	8502-748-005	8502-748-005	8502-748-005	1
*	Lockout Warning Label	8502-748-008	8502-748-008	8502-748-008	1
*	Read Operators Manual Label	8502-748-009	8502-748-009	8502-748-009	2
*	PE Mark (Ext. Protective Ground) Label	8502-748-015	8502-748-015	8502-748-015	1

Wiring Schematic for 50hz Dryer -39

CAUTION: LABEL ALL WIRES PRIOR TO DISCONNECTION WHEN SERVICING CONTROLS. WIRING ERRORS CAN CAUSE IMPROPER AND DANGEROUS OPERATION. VERIFY PROPER OPERATION AFTER SERVICING.

9506-589-001A

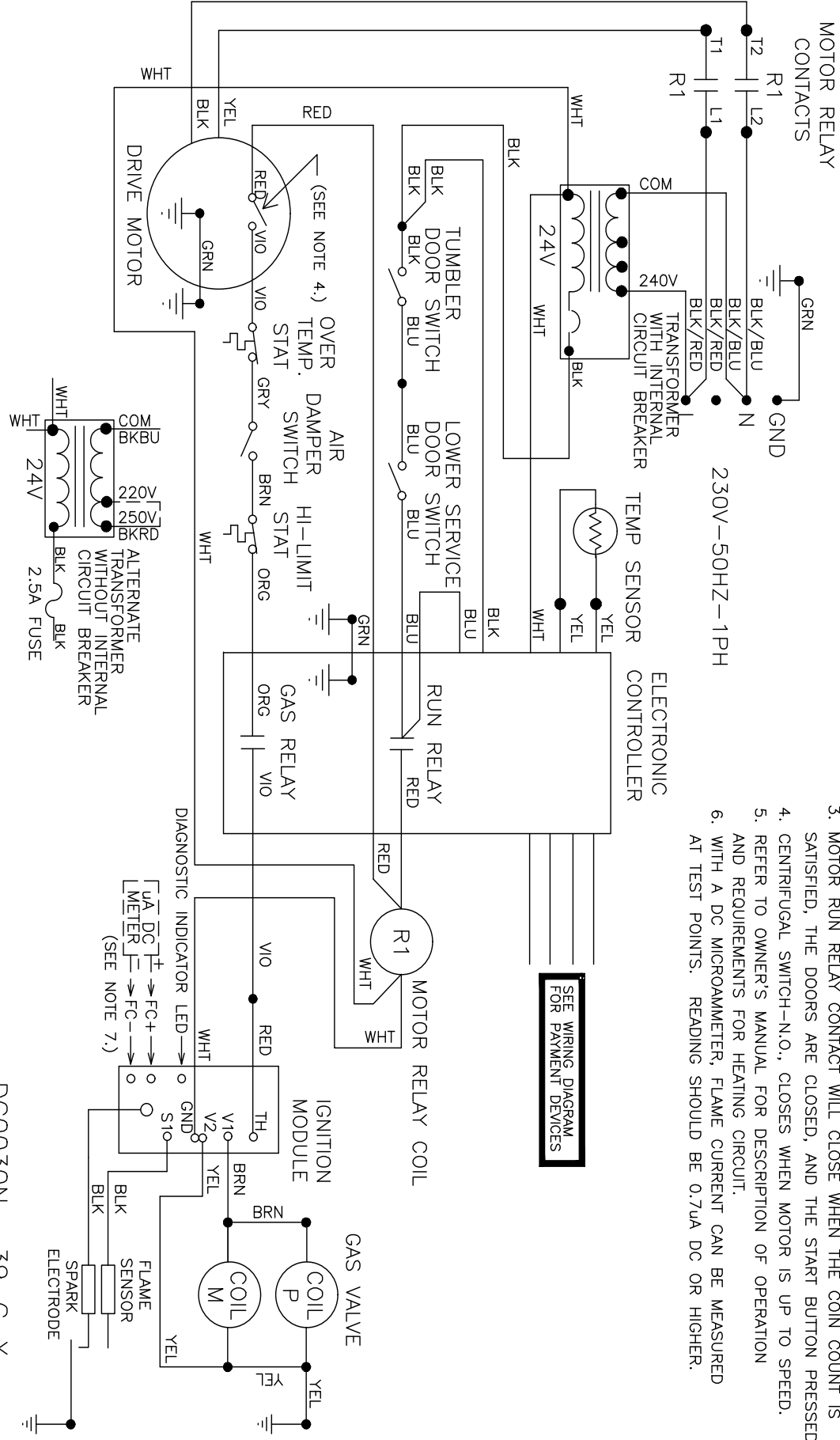

NOTES:

1. COIN SWITCH-N.O., CLOSES WHEN COIN IS INSERTED (SEE SHEET 2).
2. DOOR SWITCHES-N.O., CLOSED WHEN DOORS ARE CLOSED.
3. MOTOR RUN RELAY CONTACT WILL CLOSE WHEN THE COIN COUNT IS SATISFIED, THE DOORS ARE CLOSED, AND THE START BUTTON PRESSED.
4. CENTRIFUGAL SWITCH-N.O., CLOSES WHEN MOTOR IS UP TO SPEED.
5. REFER TO OWNER'S MANUAL FOR DESCRIPTION OF OPERATION AND REQUIREMENTS FOR HEATING CIRCUIT.
6. WITH A DC MICROAMMETER, FLAME CURRENT CAN BE MEASURED AT TEST POINTS. READING SHOULD BE 0.7uA DC OR HIGHER.

SEE WIRING DIAGRAM FOR PAYMENT DEVICES

Wiring Diagram for 50hz Dryer -39

NOTES:

1. COIN SWITCH-N.O., CLOSES WHEN COIN IS INSERTED (SEE SHEET 2).
2. DOOR SWITCHES-N.O., CLOSED WHEN DOORS ARE CLOSED.
3. MOTOR RUN RELAY CONTACT WILL CLOSE WHEN THE COIN COUNT IS SATISFIED, THE DOORS ARE CLOSED, AND THE START BUTTON PRESSED.
4. CENTRIFUGAL SWITCH-N.O., CLOSES WHEN MOTOR IS UP TO SPEED.
5. REFER TO OWNER'S MANUAL FOR DESCRIPTION OF OPERATION AND REQUIREMENTS FOR HEATING CIRCUIT.
6. WITH A DC MICROAMMETER, FLAME CURRENT CAN BE MEASURED AT TEST POINTS. READING SHOULD BE 0.7uA DC OR HIGHER.

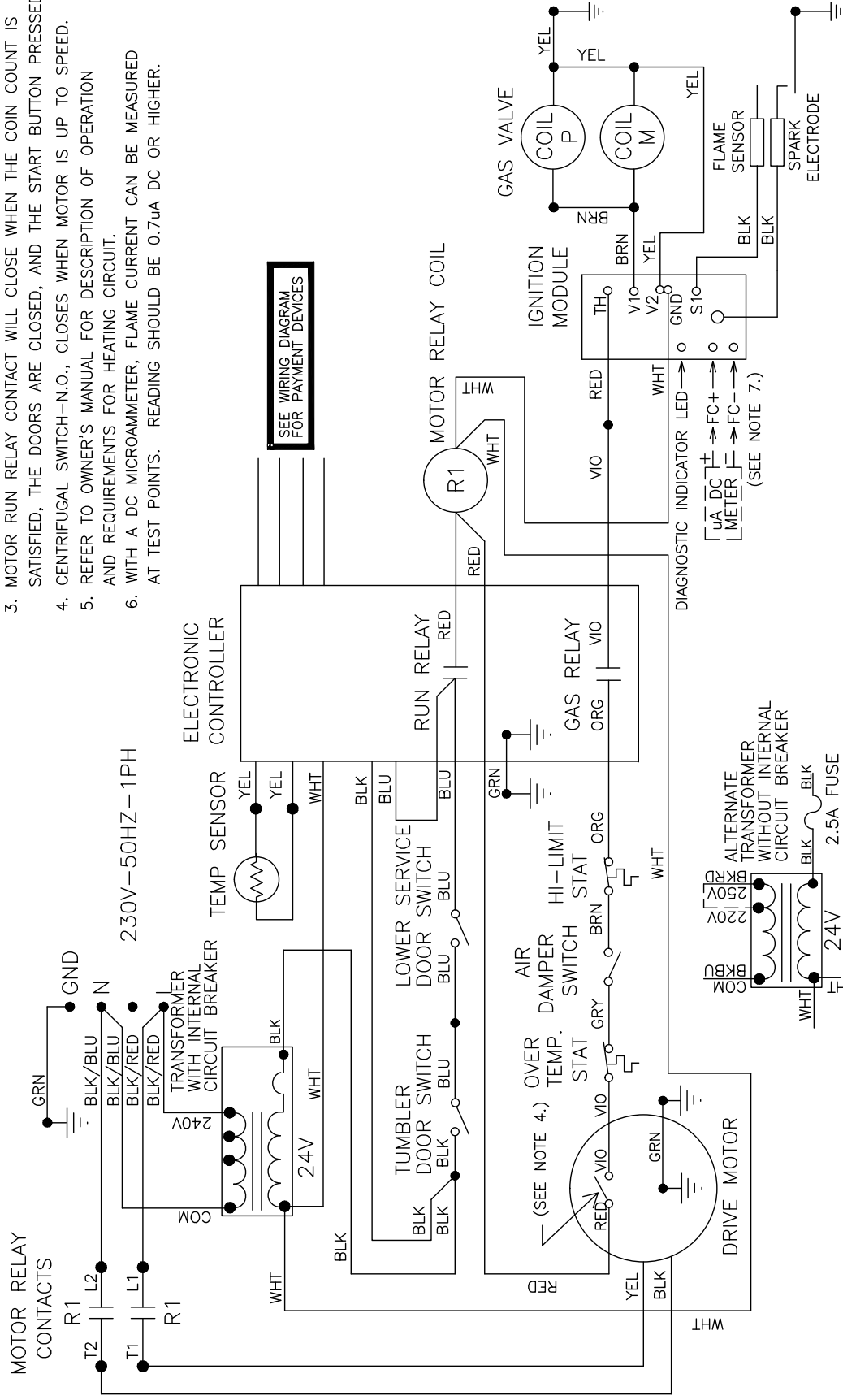

CAUTION: LABEL ALL WIRES PRIOR TO DISCONNECTION WHEN SERVICING CONTROLS. WIRING ERRORS CAN CAUSE IMPROPER AND DANGEROUS OPERATION. VERIFY PROPER OPERATION AFTER SERVICING.

9506-589-001A

DC0030N_-39_C_X

DC0050N_-39_C_X

DC0080N_-39_C_X

SCHEMATIC

Wiring Schematic for 50hz Dryer -59 (After Serial)

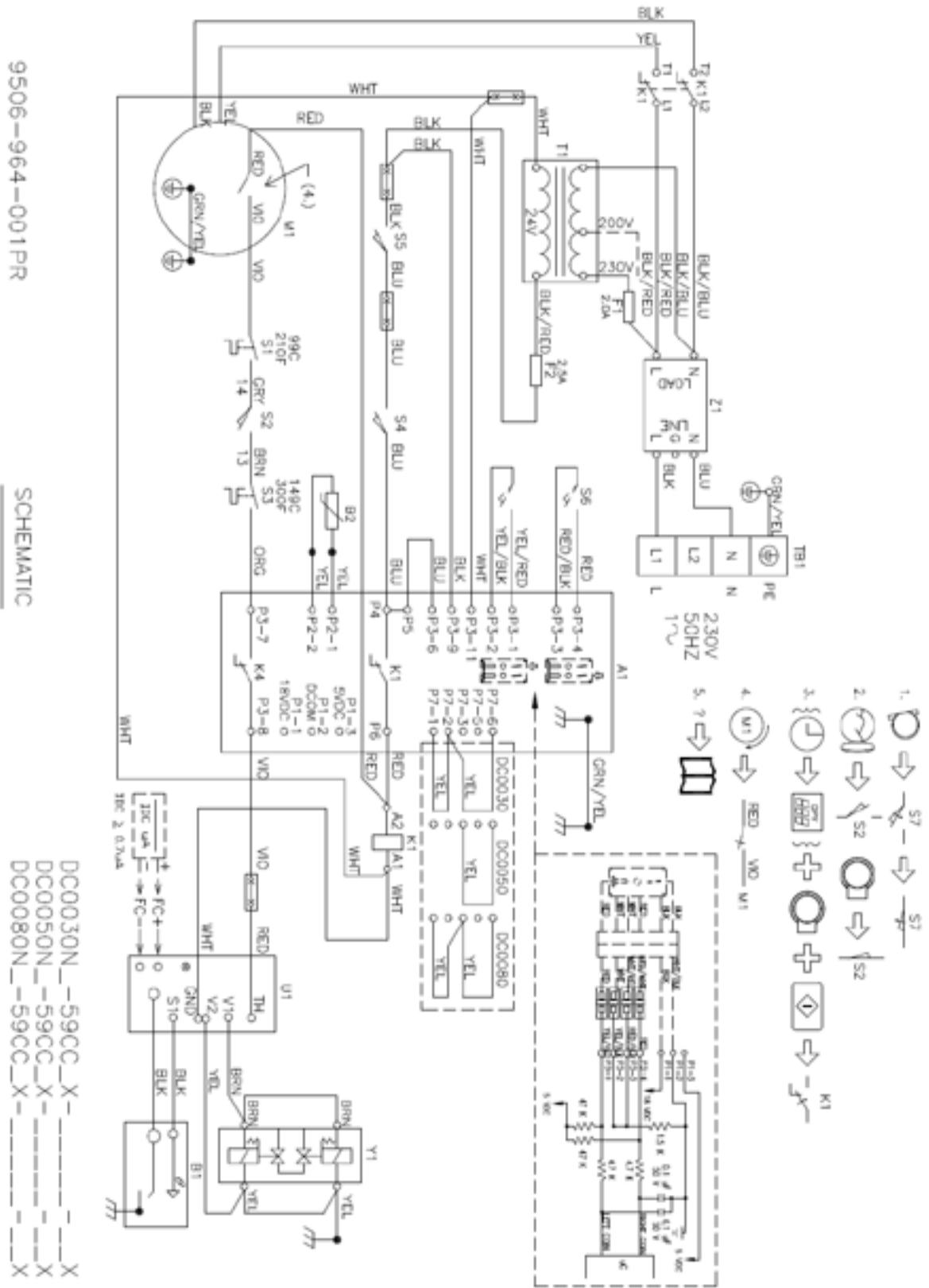

Wiring Diagram for 50hz Dryer -59 (After Serial)

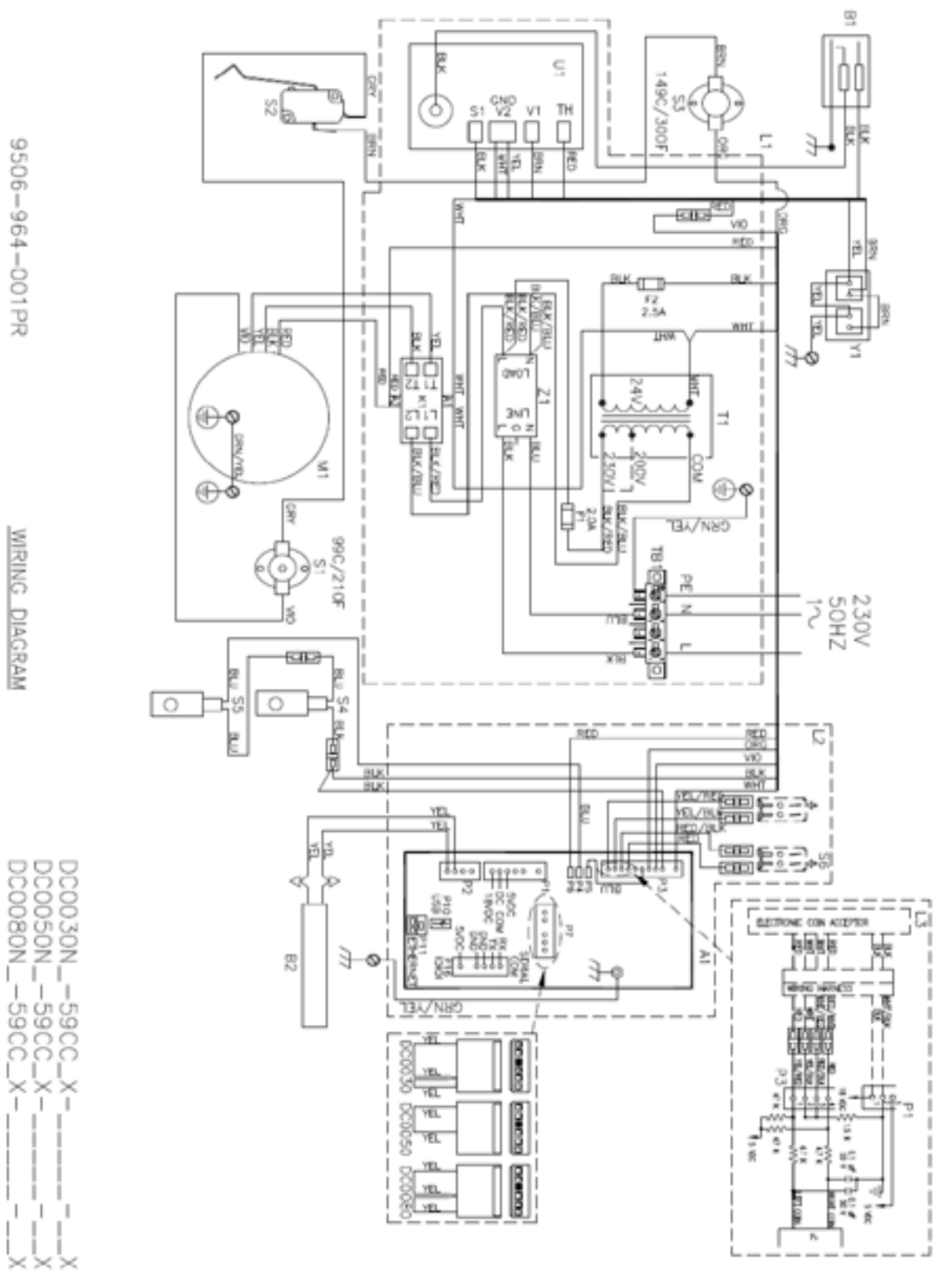

Wiring Schematic for 50hz Dryer -59 (Before Serial)

9506-644-001B

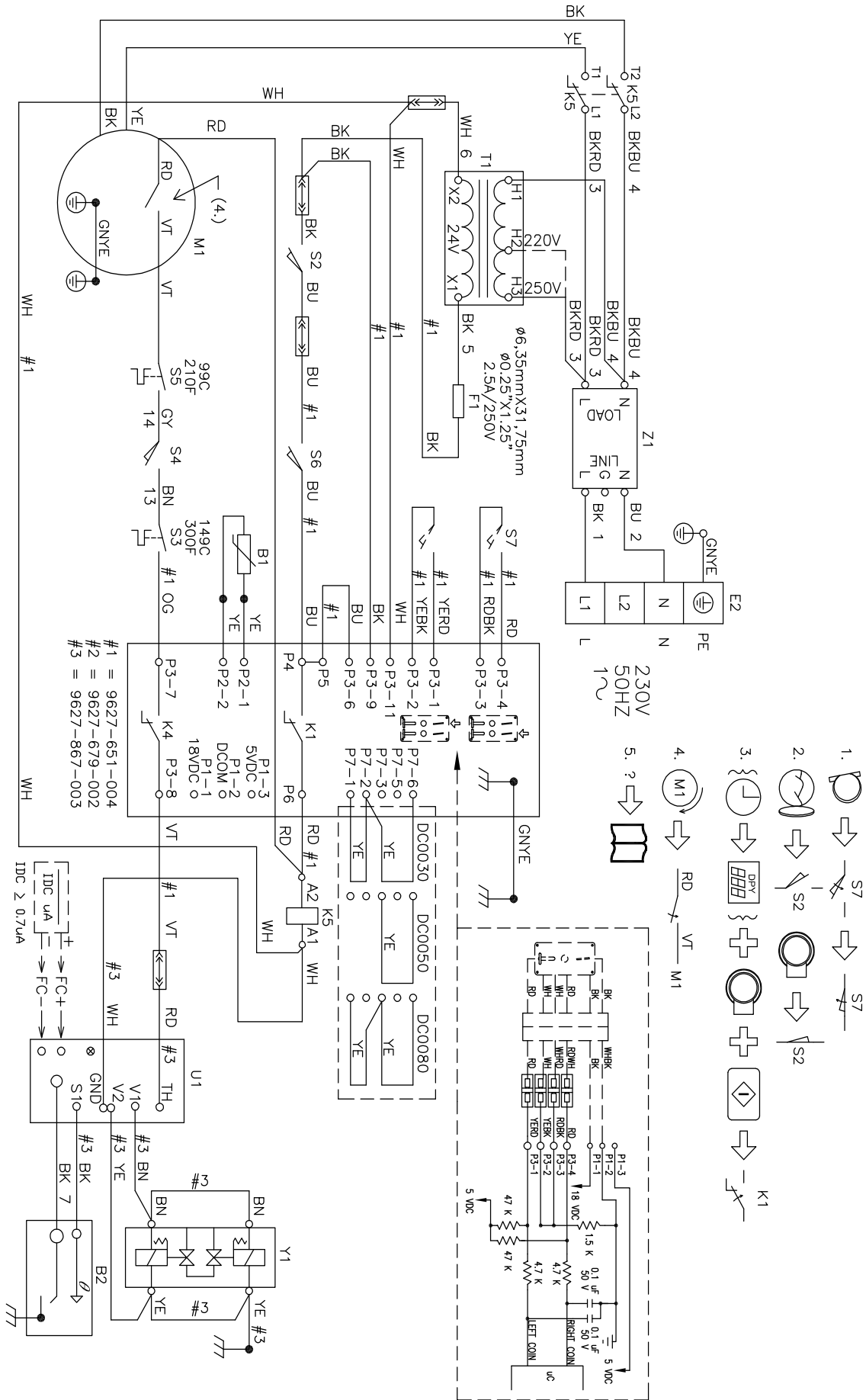

Wiring Diagram for 50hz Dryer -59 (Before Serial)

