



DEXTER[®]
LAUNDRY

**USE THE BLUE TABS LOCATED ON THE
LEFT SIDE OF THE FOLLOWING DOCUMENT TO
ADVANCE TO EACH SECTION.**

Kits, Assemblies, & Common Parts

Description	Part Number
Kit Replacement for 9376-317-005	9732-357-001
LP to Natural Conversion Kit for White Rodgers	9732-142-004
Kit, A to C-Series Conversion, Black 120V	9732-307-002
Kit, A to C-Series Conversion, Blue 120V	9732-307-001
Kit, Optional Replacement for Round Switch 9539-492-001	9732-351-001
Temperature Probe	9501-004-002
Controlasy-t120coin, 1.5,24 (Blk)	9857-199-006
Controlasy-t120coin, 1.5,24 (Blu)	9857-199-005
Ignition Control Box	9627-182-001
Electrode Assembly, Ignition	9675-002-003
Thermostat, Hi-Limit	9576-203-002
Thermostat, Overtemp	9576-207-006
Motor Run Relay	5192-299-002
Transformer	8711-007-002
Lint Screen	9822-033-001
Air Flow Switch	9539-461-009
Motor Belt	9040-076-008
Tumbler Belt	9040-076-005
Spider/Trunnion	9568-016-001
Door Handle	9244-093-001
Switch-Door (Round)	9539-492-001
Switch-Door (Square)	9539-501-001
Optical Coin Acceptor	9021-094-001
Retainer-coinacceptor	9486-145-001
Electronic Coin Acceptor Kit (Optional)	9732-303-004



Section 5: Dryer Parts Data

DC0120NE-10EC2R

Dryer Cabinet Front Panel

Key	Description	T-120	
*	Loading Door Complete Wht/Brushed SS/Blk	9960-331-001	1
1	Door Assy, Loading (Ring only) Brushed SS	9960-330-001	1
*	Doorassy-load,ss/chr/blk (Chrome)	9960-331-002	1
*	Door Assy, Loading (Ring only) Chrome	9960-330-002	1
2	Plate Assy, Hinge	9982-398-001	1
*	Cover-Hinge Back, Black	9982-397-001	1
*	Screw-10Bx3/8, Black	9545-008-010	2
*	Screw Hinge to Door	9545-012-015	4
*	Nut, Hinge to Door	8640-413-002	4
3	Glass, Door	9212-002-006	1
*	Adhesive-Door Glass, 10.3 oz. tube (24-Hour Cure Time)	8561-138-002	1
4	Optical Coin Acceptor	9021-094-001	1
*	Optical Coin Acceptor Extension Harness	9627-916-004	1
*	Retainer-coinacceptor	9486-145-001	1
*	Electronic Coin Acceptor Kit (Optional)	9732-303-004	1
*	Nut, Elastic Stop	8640-413-004	*
*	Electronic Coin Acceptor Extension Harness (Optional, NOT included in Kit above)	9627-909-006	1
5	Gasket, Door Outer Rim (Black)	9206-420-007	1
6	Handle, Loading Door	9244-093-001	1
*	Screw, Handle	9545-018-017	2
7	Stud Door Catch 7/8"	9531-033-002	1
8	Nut-Hex, #10-32	8640-413-001	1
9	Nut, Acorn	8640-413-003	1
*	Catch, Loading Door	9086-015-002	2
*	Rivet	9491-009-004	2
10	Strap, Hinge (Black)	9966-023-002	1
*	Channel Assy-Front Panel	9947-024-001	1
*	Screw-Phillips, 10-32x1/2 Chrome	9545-012-028	4
*	Screw-Phillips-Counter sink, 10-32x1/2 Chrome	9545-012-003	2
11	Screw-Special, Hinge to Door	9545-052-001	1
*	Nut-Allen, 1/4-20S	8640-439-001	1
12	Washer-Fiber/Plastic	8641-436-006	1
13	SS Front Panel Assy (Blk) Round Switch	9989-688-001	1
13	SS Front Panel Assy (Blk) Square Switch	9444-011-001	1
13	White Front Panel Assembly (Blk)	9989-688-003	1
*	Insulation-Front Panel	9277-065-001	1
*	Label-Warning	8502-758-001	1
14	Screw-Phillips, 10Bx1 3/4	9545-008-014	10
15	Washer-Finish	8641-585-001	10
*	Nut-Spring	8640-399-001	10
*	Switch-Door (Round)	9539-492-001	1
*	Switch-Door (Square)	9539-501-001	1
17	Vaultassy-coin,black	9942-039-002	1
*	Coin Vault Cover	9825-064-001	
18	Controlasy-t120coin, 1.5,24 (Blk)	9857-199-006	1
*	Controlasy-t120coin, 1.5,24 (Blu)	9857-199-005	1
19	Overlay-Controltrim,-t-120, (Blk)	9435-067-001	1
	Overlay-Controltrim,-t-120, (Blu)	9435-067-002	1

Dryer Cabinet Group

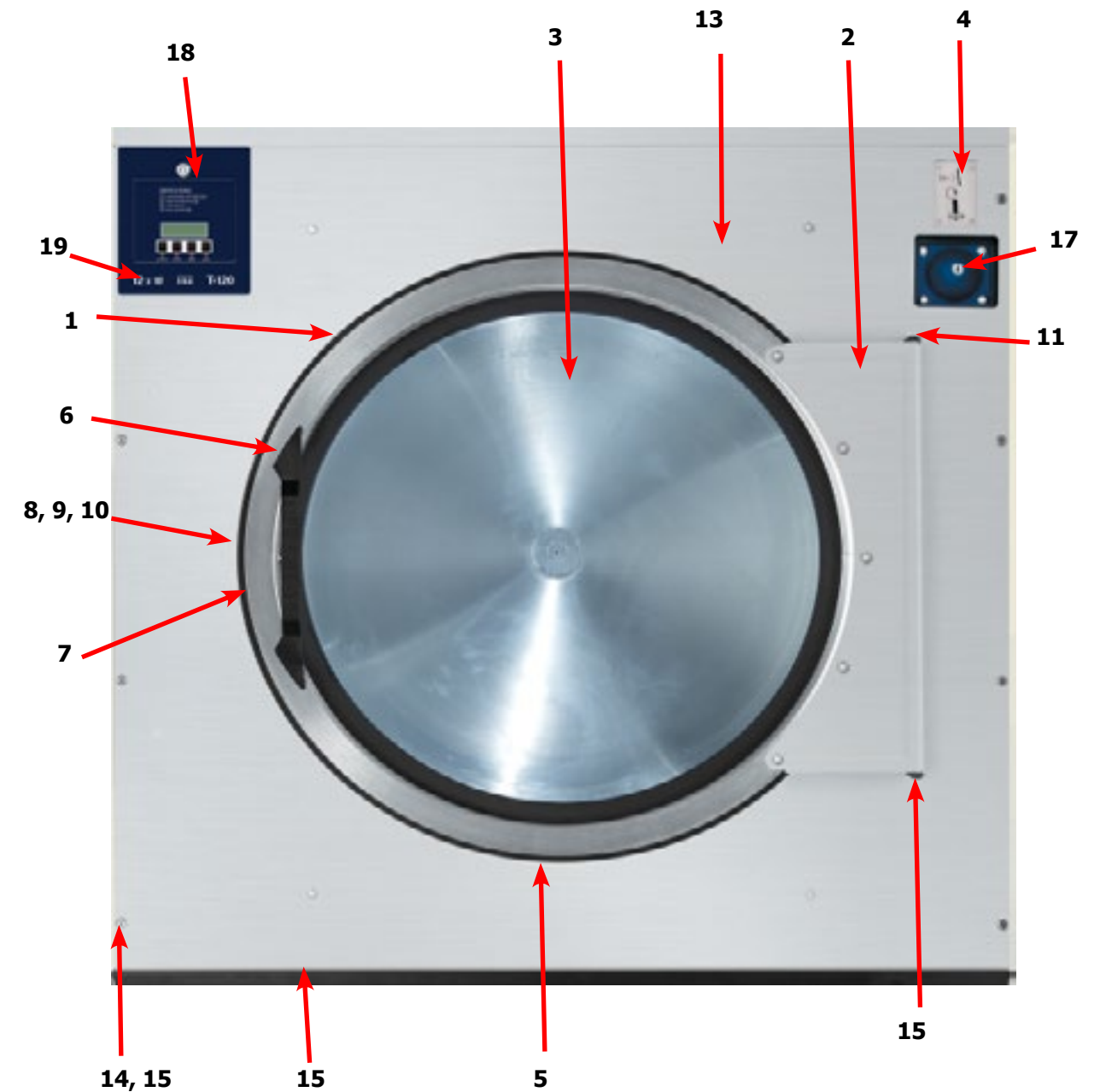

Dryer Cabinet Group Continued

Key	Description	T-120	QTY
1	Nameplate - Dexter Dryer Black	9412-216-001	1
2	Panel Assy-Upper	9960-328-007	1
3	Screw-Phillips, 10Bx1 3/4	9545-008-014	4
4	Washer-Finish	8641-585-001	4
*	Nut-Spring	8640-399-001	4
5	Lockassemblyandkey	8650-012-003	1
*	Cam-lock	9095-041-001	1
*	Washer-flat	8641-851-041	1
*	Key, 6324	6292-006-007	4
6	Overlay-Controltrim,-t-120, (Blk)	9435-067-001	1
*	Overlay-Controltrim,-t-120, (Blu)	9435-067-002	1
7	Controlasy-t120coin,1.5,24 (Blk)	9857-199-006	1
*	Controlasy-t120coin, 1.5,24 (Blu)	9857-199-005	1
8	Front Panel Assembly Round Switch	9989-688-001	1
8	Front Panel Assembly Square Switch	9444-011-001	1
*	Insulation front panel	9277-065-001	1
*	Switch-Door (Round)	9539-492-001	1
*	Switch-Door (Square)	9539-501-001	1
*	Screw, #10-32 x1/2 Green	9545-008-027	1
9	Escutcheon Assemble-coin, t-120	9994-052+001	1
10	Optical Coin Acceptor	9021-094-001	1
*	Optical Coin Acceptor Extension Harness	9627-916-001	1
*	Retainer-coinacceptor	9486-145-001	1
*	Electronic Coin Acceptor Kit (Optional)	9732-303-004	1
*	Electronic Coin Acceptor Extension Harness (Optional, NOT included in Kit above)	9627-909-006	1
11	Vaultassy-coin,black	9942-039-002	1
*	Harness-Control	9627-770-002	1
*	Door switch wireharness	9627-948-001	1
*	Harness-Temp Probe	9627-679-002	1
*	Label-Warning	8502-758-001	1
*	Wiringharness-optcoin,t-120	9627-916-004	1
*	Wiringharness-main,t-120	9627-949-001	1
*	Wireasy-grn/ylw,#16,24"	8220-137-001	1
*	Door switch harness	9627-948-001	1
*	Cabinet Touch Up Paint (White)	9472-001-013	1



Dryer Cabinet Group Continued

Key	Description	T-120	QTY
*	Assembly-Door-Lower Service, OPL, Wht (Number 1 thru 14)	9960-307-001	1
1	Door-Lower Service, OPL, Wht	9108-148-003	1
2	Handle-Door, Lower Service, Black	9244-090-002	1
*	Screw-Phillips, 10Bx3/8, Black	9545-008-010	5
*	Cam-lock	9095-041-001	1
*	Washer-flat	8641-851-041	1
*	Key, 6324	6292-006-007	1
3	Lockassemblyandkey	8650-012-003	2
4	Trim-Lower Kick, Black	9578-100-002	1
5	Screw-Phillips, 10Bx3/8, Black	9545-008-010	5
6	Bracket, Lower door switch, (Hinge Bracket)	9029-226-001	2
7	Rivet, 1/8 Low Profile	9491-009-004	4
8	Nut, Elastic Stop, 10-32 UNF	8640-413-007	2
9	Screw. 10-32 x 1/2"	9545-012-003	1
*	Screw. 10-32 x 1/2"	9545-012-003	1
10	Insulation	9277-059-001	1
11	Switch-Door (Round)	9539-492-001	2
*	Switch-Door (Square)	9539-501-001	1
*	Kit, Optional Replacement for Round Switch 9539-492-001	9732-351-001	1
12	Screen Assy, Lint	9822-033-001	1
*	Footing Foot	9188-016-001	4

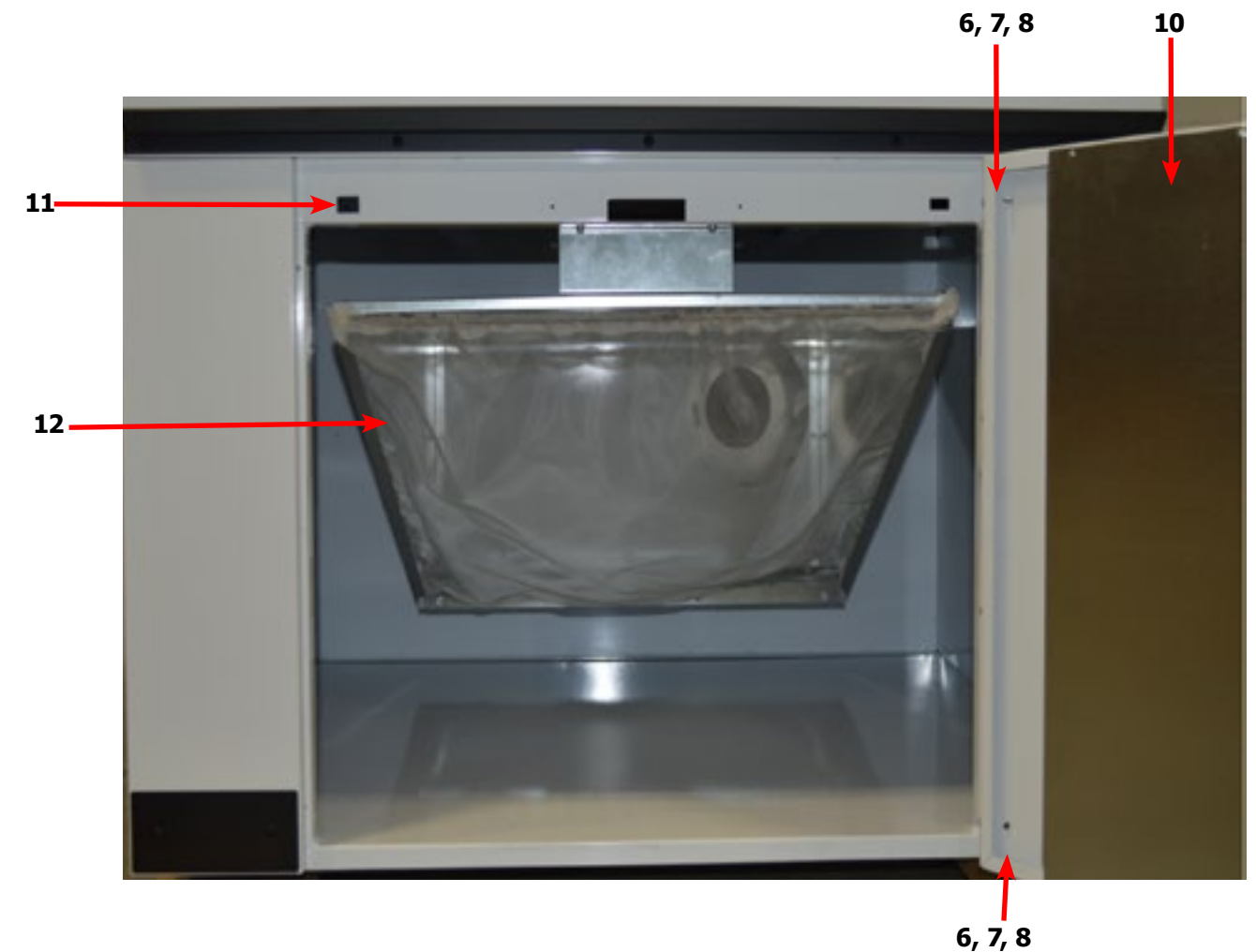
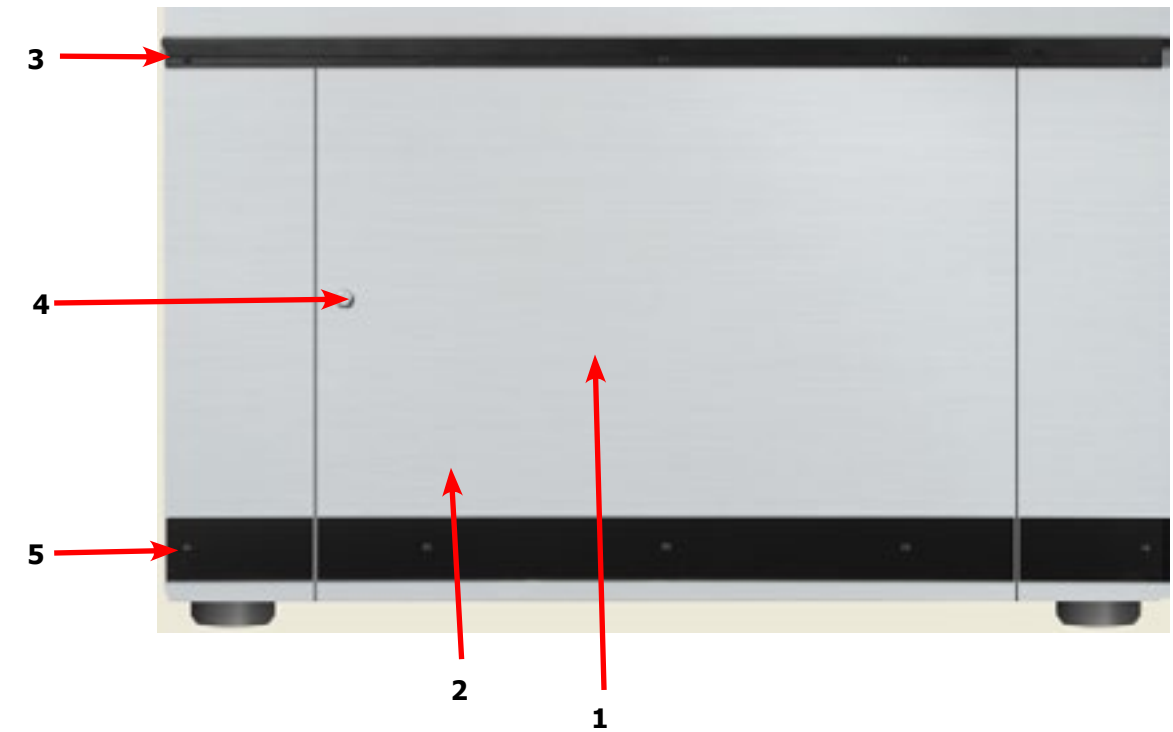

Dryer Cabinet Group Continued

Key	Description	T-120	QTY
1	Panel Assy.-Upper Right	9989-549-002	1
*	Screw, 5/16- 10ABx3/8	9545-008-024	2
2	Insulation-Right Upper, Burner Area	9277-041-022	1
3	Panel Assy.-Upper Left	9989-550-002	1
*	Screw, 5/16- 10ABx3/8	9545-008-024	2
4	Insulation Tumbler Area, Right (Front & Back)	9277-051-005	2
4	Insulation Tumbler Area, Right (Center)	9277-051-006	1
5	Insulation Tumbler Area, Left (Front & Back)	9277-051-005	2
5	Insulation Tumbler Area, Left (Center)	9277-051-006	1
6	Switch-Door (Round)	9539-492-001	2
*	Switch-Door (Square)	9539-501-001	
*	Screen Assy, Lint	9822-033-001	1
*	Lint Hood Assembly	9834-012-001	1
7	Lint Hood, Top	9240-048-001	1
*	Lint Hood, side left	9240-049-001	1
*	Link Hood, side right	9040-049-002	1
8	Lint Hood, Bottom	9058-030-001	1
9	Lint Hood, Angle	9003-333-001	1
10	Screw, 5/16- 10ABx3/8	9545-008-024	22
11	Hinge-Door, Lower	9243-083-002	1
*	Screw-5/16, 10ABx3/8	9545-008-024	5
12	Impeller, w/set screws	9278-041-001	1
13	Harness -Temp Probe	9627-949-001	1
14	Wire Nut, #71B	8640-276-005	2
15	Temp Probe	9501-004-003	1
16	Screw-Phillips, 8Bx1/4	9545-045-005	1
17	Bracket, Temp Probe	9029-111-001	1
18	Screw, 8AB x 3/8	9545-045-008	4
19	Trim-Edge, Lint Hood	9578-092-003	2
20	Lowerservicedoor-Hinge, black	9243-084-003	
21	Strapasy-hinge, lwrservdr	9966-022-001	11

120Lb. Temp Probe

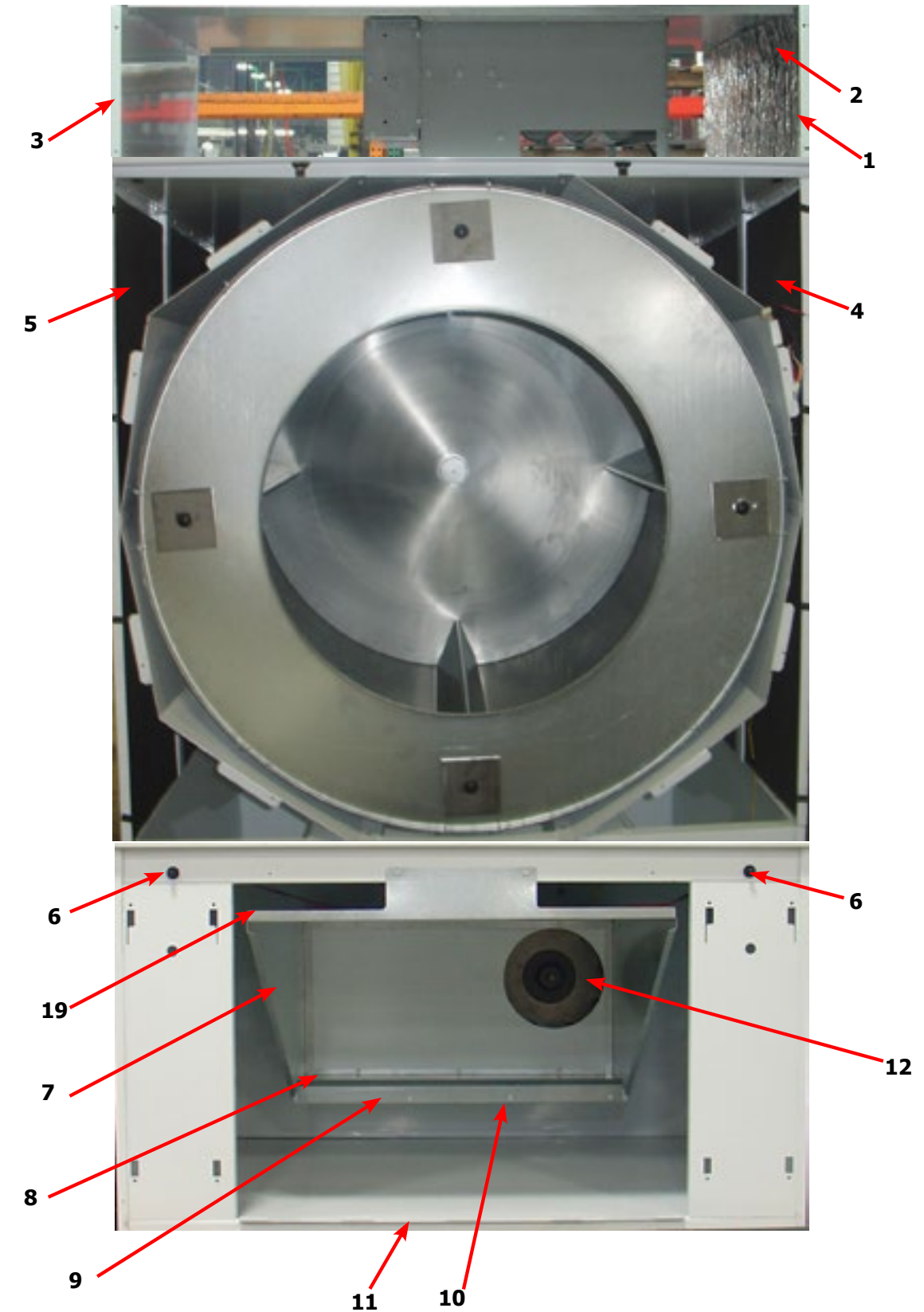
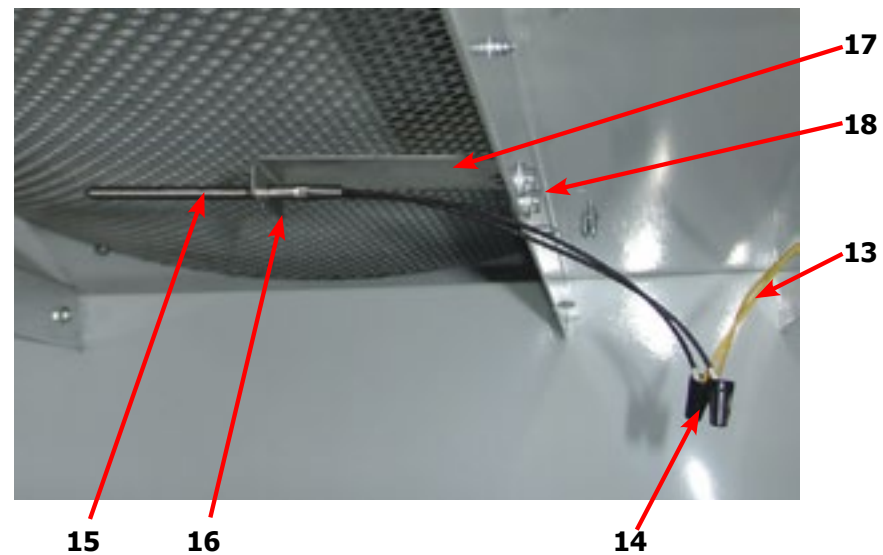

Dryer Modular Cabinet Group 120lb. (After Serial D1.23179.001)

Key	Description	T80	QTY
1	Cabinet Base Assembly	9945-172-001	1
*	Lower Back Panel Assembly	9989-754-002	1
2	Lower Cabinet RH Side Panel	9444-125-003	1
3	Lower Cabinet LH Side Panel	9444-125-004	1
4	Lower Cabinet Front Channel	9081-217-001	1
*	Upper Back Panel Assembly	9989-717-002	1
5	RH Middle Side Panel Assembly	9989-543-003	1
6	LH Middle Side Panel Assembly	9989-543-004	1
7	Cabinet Top Cover	9074-356-001	1
8	Baffle	9049-135-001	4
*	Baffle Stiffener Angle	9003-388-001	2
9	RH Upper Side Panel Assembly	9989-549-002	1
10	LH Upper Side Panel Assembly	9989-550-002	1
*	10abx3/8 Screw	9545-008-024	92
*	3/16 Blind Rivet	9491-009-001	131
*	Wht 3/16 Blind Rivet	9491-009-005	58
*	Hex kep Nut 1/4-20unc, 2b	8640-414-006	10
*	Upper Service Door Assembly, Wht/Blk	9960-361-001	1
*	Upper Service Door Assembly, Wht/Blu	9960-361-002	1
*	Upper Service Door Assembly, SS/Blk	9960-361-003	1
*	Upper Service Door Assembly, SS/Blu	9960-361-004	1
*	Screw	9545-008-014	2

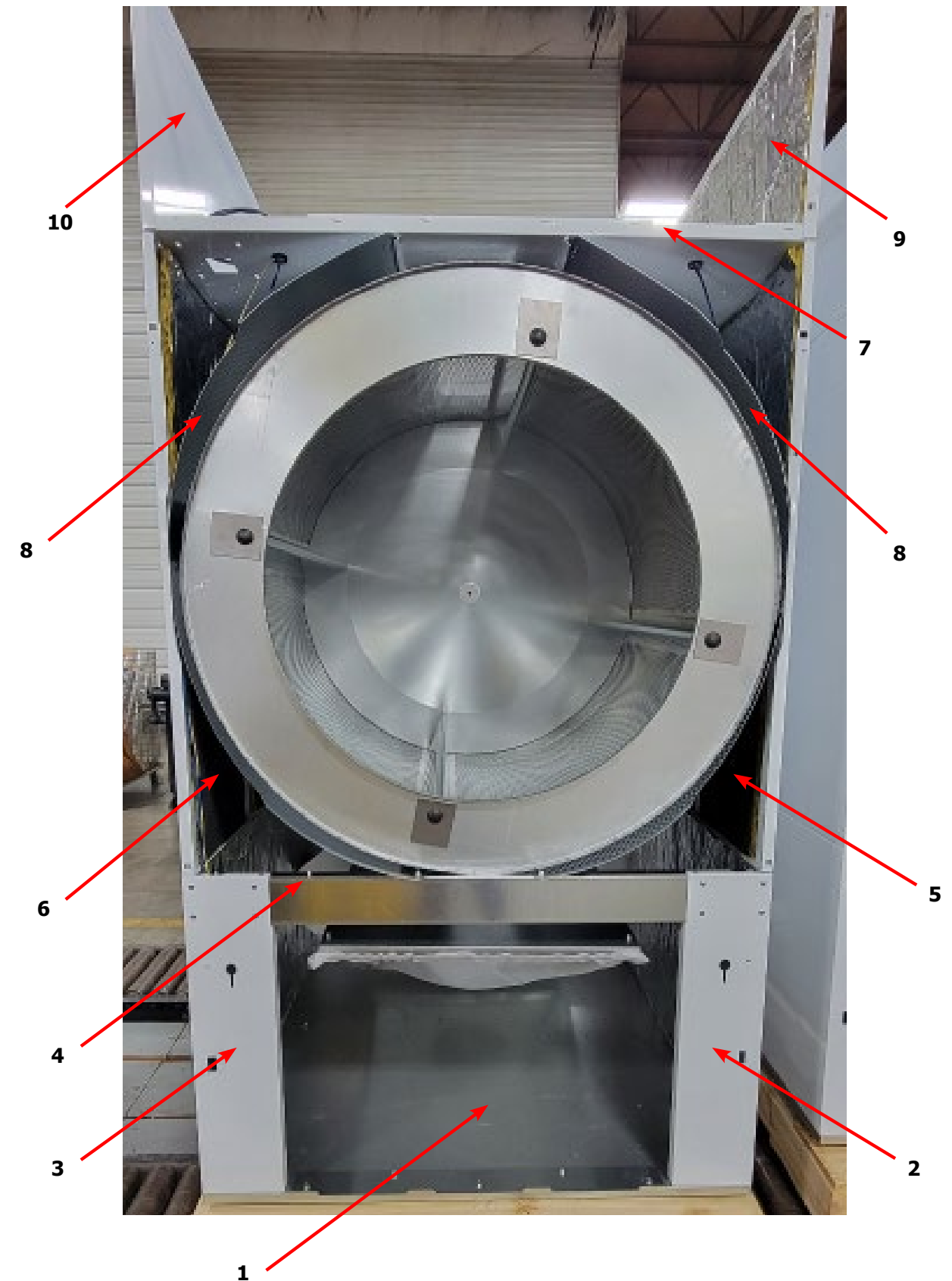

Dryer Rear View 120Lb Reversing

Key	Description	T-120	QTY
1	Pulley, Driven	9453-168-003	1
2	Tolerance Ring	9487-234-006	1
3	Washer -Flat	8641-581-032	1
4	LockWasher - IntTooth, 1"	8641-582-018	1
5	Screw, 5/8-11 x 1 1/2	9545-060-001	1
6	Belt-Driven	9040-076-005	2
*	Impeller, 5" x 16"	9278-041-001	1
7	Plate Assembly-Impeller	9982-375-002	1
8	Nut-Wiz Lock, 5/16-18	8640-400-003	6
*	Gasket-Impeller Housing	9206-428-002	1
9	Motor-Blower, -10	9376-334-001	1
*	Run Capicator	5191-108-005	1
*	Start Capicator	5191-109-005	1
10	Screw, 5/16-18 x 5/8	9545-014-004	4
11	Nut-Wiz Lock, 5/16-18	8640-400-003	4
12	Thermostat-Overtemp	9576-207-006	1
13	Screw-10AB x 3/8	9545-008-006	2
14	Pulley, Intermediate, w/Bearings	9908-051-001	1
*	Bearings-Ball	9036-159-011	2
*	Spacer-Bearings	9538-186-001	1
*	Ring-Retaining, Internal	9487-238-006	1
15	Washer-Flat	8641-581-039	1
16	Nut, 5/8-11	8640-425-002	1
17	Belt, Motor	9040-076-008	1
18	Motor, Drive	9376-307-003	1
19	Pulley-Motor	9453-074-002	1
20	Bushing, Motor -Support	9497-222-008	2
21	Rod-Motor Mounting, Black	9497-222-008	1
22	Collar-Shaft, w/Set Screws	9076-052-002	1
23	Chain-Belt tension	9099-012-004	1
*	Hook-S Type	9248-022-002	1
24	Spring, Belt Tension	9534-151-000	1
25	Duct-Transition, 12" to 10"	9109-124-001	1

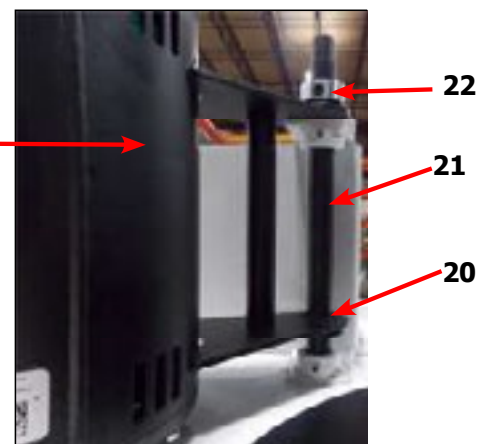
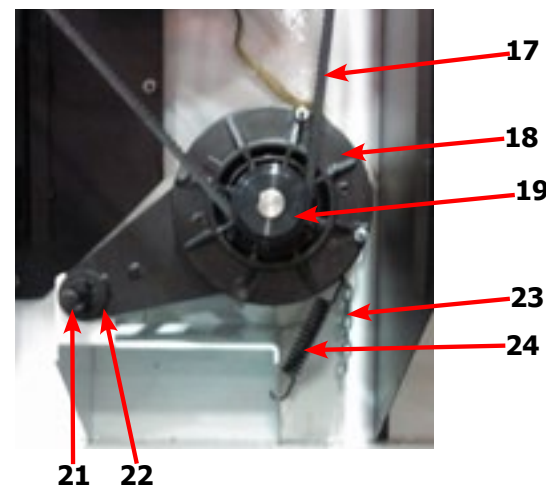

Dryer Rear View 120Lb Reversing

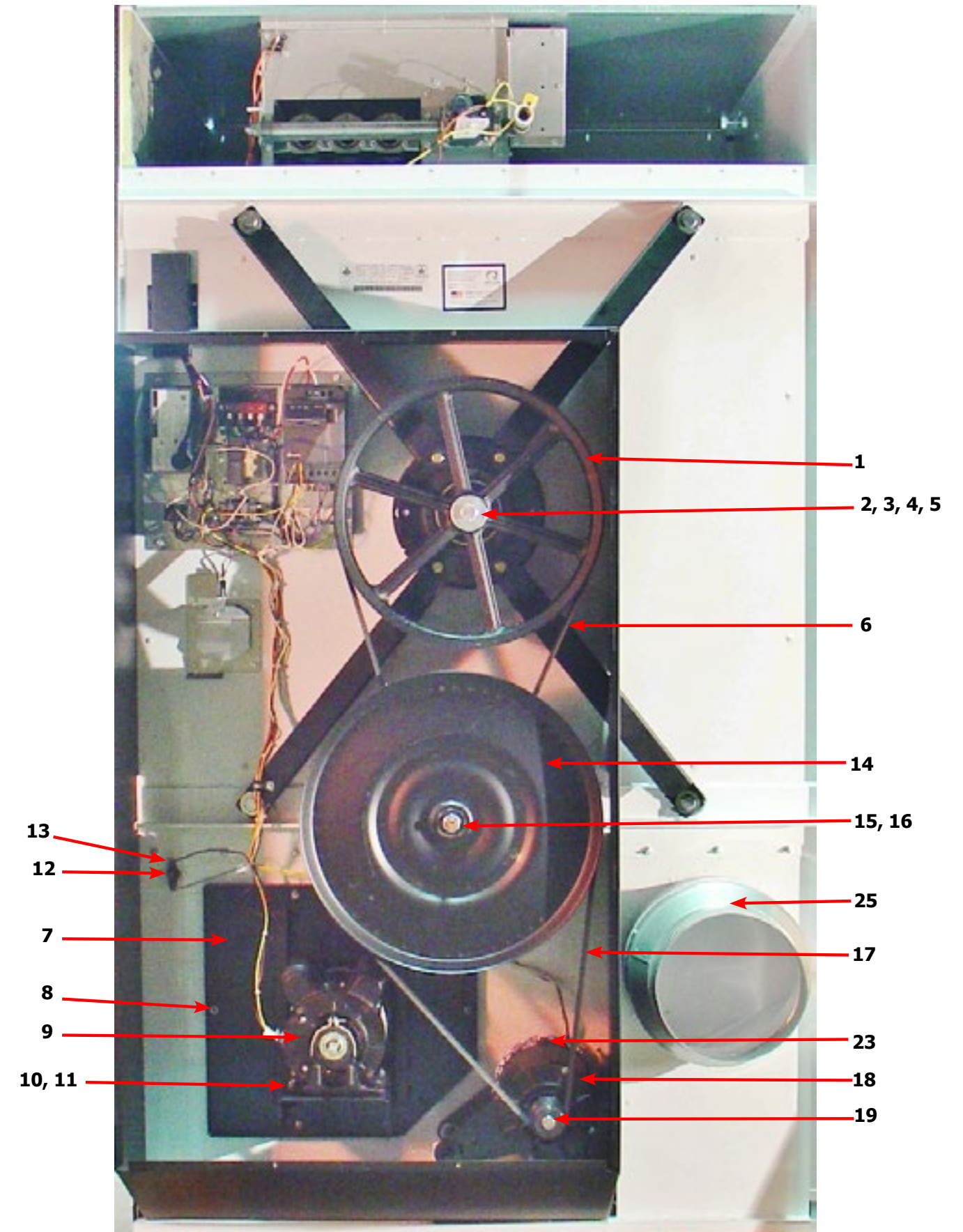

Dryer Rear View 120Lb Reversing Continued

Key	Description	T-120	QTY
1	Pulley, Driven	9453-168-003	1
2	Tolerance Ring	9487-234-006	1
3	Washer -Flat	8641-581-032	1
4	LockWasher - IntTooth, 1"	8641-582-018	1
5	Screw, 5/8-11 x 1 1/2	9545-060-001	1
6	Plate Assembly-Intermediate, Tension	9982-378-002	1
7	Rod-Intermediate, Pivot	9497-230-002	1
8	Collar, Locking	9076-060-001	1
9	Bolt, 1/2-13 x 1 1/2	9545-017-001	2
10	Thermostat-Overtemp	9576-207-006	1
11	Screw-10AB x 3/8	9545-008-006	2
*	Impeller, 5" x 16"	9278-041-001	1
12	Plate Assembly-Impeller	9982-375-002	1
13	Nut-Wiz Lock, 5/16-18	8640-400-003	6
*	Gasket-Impeller Housing	9206-428-002	1
14	Motor-Blower	9376-334-001	1
*	Run Capicator	5191-108-005	1
*	Start Capicator	5191-109-005	1
15	Screw, 5/16-18 x 5/8	9545-014-004	4
16	Nut-Wiz Lock, 5/16-18	8640-400-003	4
17	Motor, Drive	9376-307-003	1
18	Pulley-Motor	9453-169-012	1
*	Bushing, Motor -Support	9053-074-002	2
19	Rod-Motor Mounting, Black	9497-222-008	1
20	Collar-Shaft, w/Set Screws	9076-052-002	1
21	Chain-Belt tension	9099-012-004	1



7 8 6



9 6

Dryer Rear View 120Lb Reversing Continued

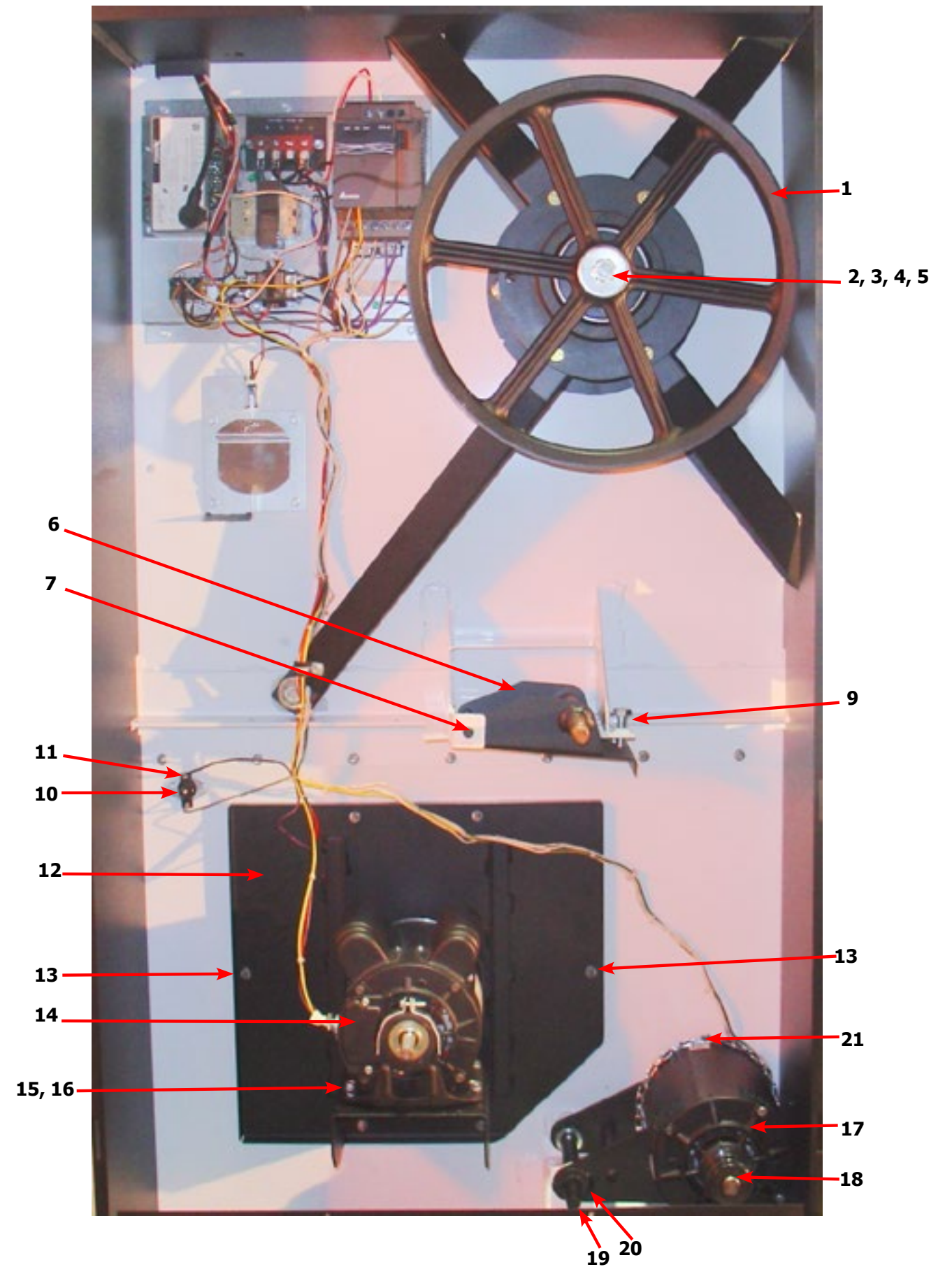

Dryer Rear View-Guard & Exhaust

Key	Description	T-120	QTY
1	Cover Cabinet	9074-356-001	1
*	Screw-5/16, 10ABx3/8	9545-008-024	10
2	Duct-Transition, 12" to 10"	9109-124-001	1
*	Screws-10-16 x 1/2	9545-008-003	3
*	Guard-Side, Right	9208-111-002	1
*	Screw-Torx T20, 10B x 3/8, BLK	9545-008-034	7
3	Guard-Side, Left	9208-110-002	1
*	Screw-Torx T20, 10B x 3/8, BLK	9545-008-034	8
4	Guard-Top	9208-112-002	1
*	Screw-Torx T20, 10B x 3/8, BLK	9545-008-034	11
5	Guard-Bottom	9208-113-002	1
*	Screw-Torx T20, 10B x 3/8, BLK	9545-008-034	6
6	Guard-Wires	9208-115-002	1
*	Screw-Torx T20, 10B x 3/8, BLK	9545-008-034	2
7	Guard-Door, Right	9208-114-004	1
*	Screw-Torx T20, 10B x 3/8, BLK	9545-008-034	6
8	Guard-Door, Left	9208-114-003	1
9	Screw-Torx T20, 10B x 3/8, BLK	9545-008-034	4
*	Nut-Spring, U-type	8640-399-001	4
*	Booklet-Owners	8514-234-001	1
10	Diagram & Schematics	9506-896-001	1
11	Label-Warning & Notice	8502-763-001	1
12	Label-Instructions	8502-645-001	1
13	Decal-Lighting & Clearance	8527-151-001	1
14	Label-High Voltage	8502-614-004	1

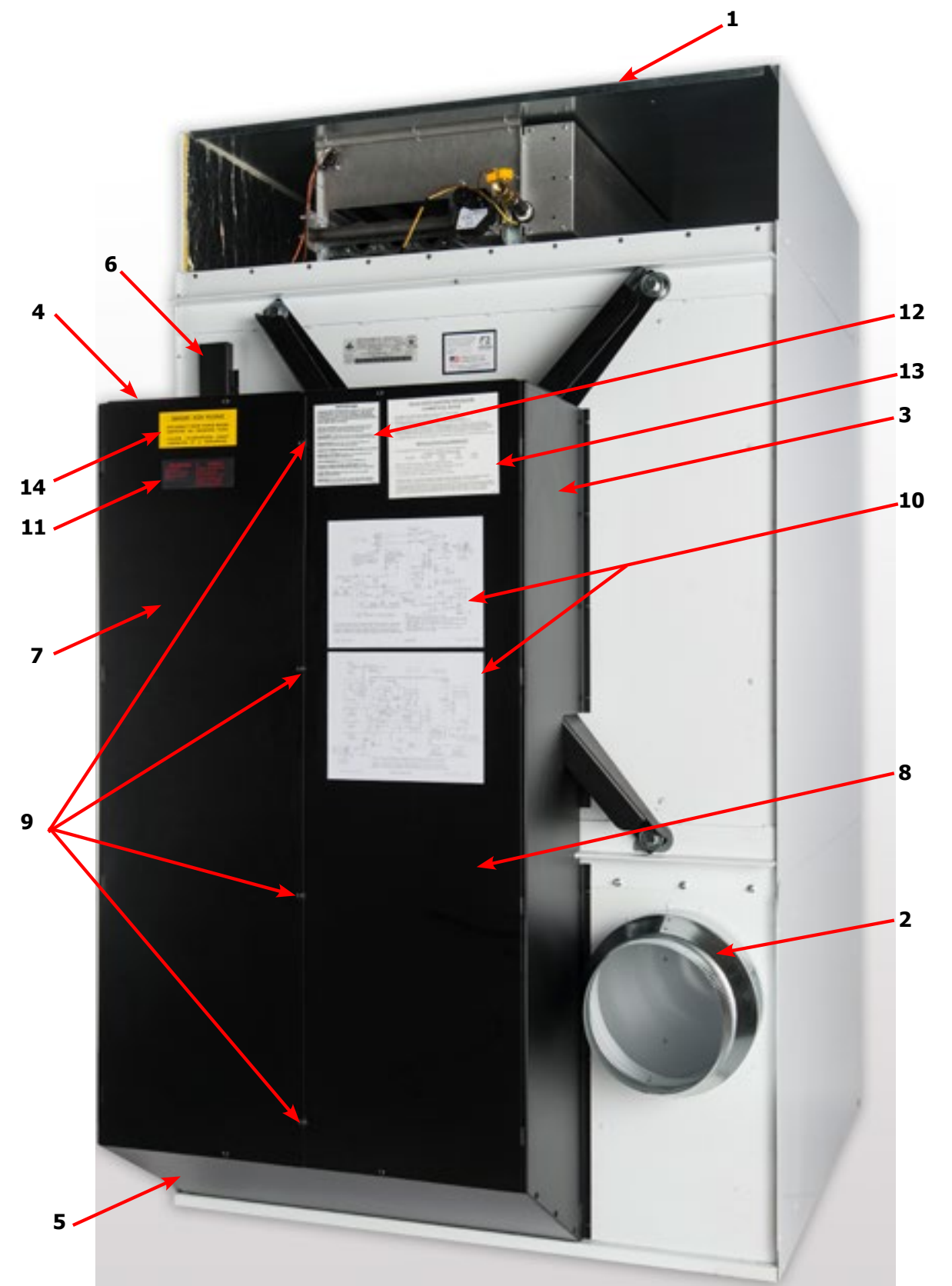

Dryer Rear View-Bearing Housing 120Lb

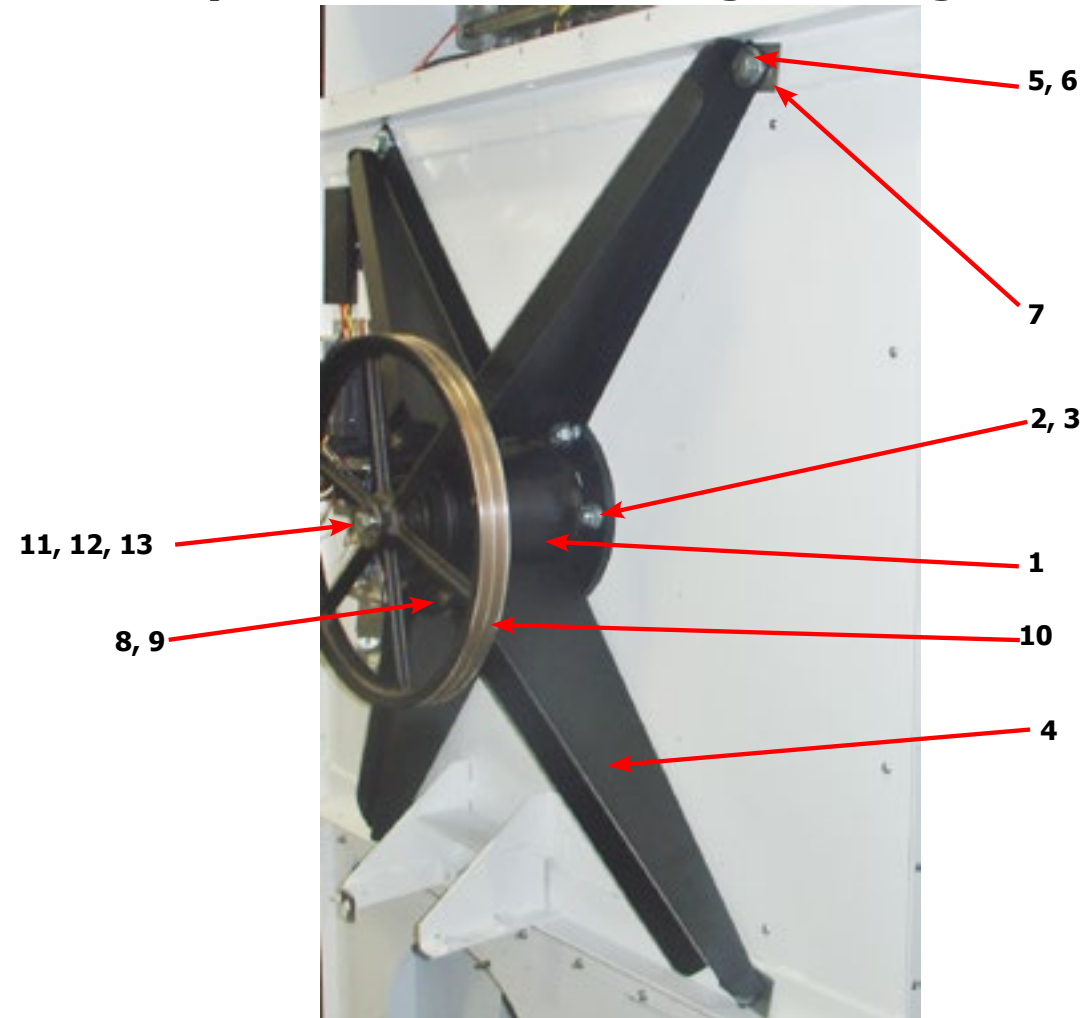

Key	Description	T-120	QTY
	Bearing Housing Complete Assy (Includes bearings & Spacer)	9803-186-001	1
1	Housing, Bearing	9241-180-002	1
*	Ring, Retaining-Internal	9487-238-003	1
*	Bearing, Ball, Front	9036-159-005	1
*	Spacer, Bearing	9538-167-001	1
*	Bearing, Ball, Rear	9036-159-004	1
*	Washer, Flat	8641-581-040	6
2	Screw-5/8"-11 x 1 1/2"	9545-060-001	6
3	Nut-Whizlock, 5/8" x 11	8640-425-001	6
4	Arm-Support Housing	9001-065-002	4
5	Screw-5/8-11 x 1 1/2	9545-060-001	4
6	Washer, Flat 5/8"	8641-581-038	4
7	Shim	9552-045-001	AR
8	Screw-7/16"-14 x 1 1/2"	9545-059-003	4
9	Nut-Whizlock, 7/16"	8640-416-005	4
*	Tolerance Ring	9487-234-006	1
10	Pulley Driven	9453-168-003	1
11	Washer, Flat 5/8" x 2 1/4"	8641-581-032	1
12	Lock Washer Spring, 1/2	8641-582-018	1
13	Screw, 5/8-11 x 1 1/2"	9545-060-001	1

Dryer Tumbler Group 120Lb

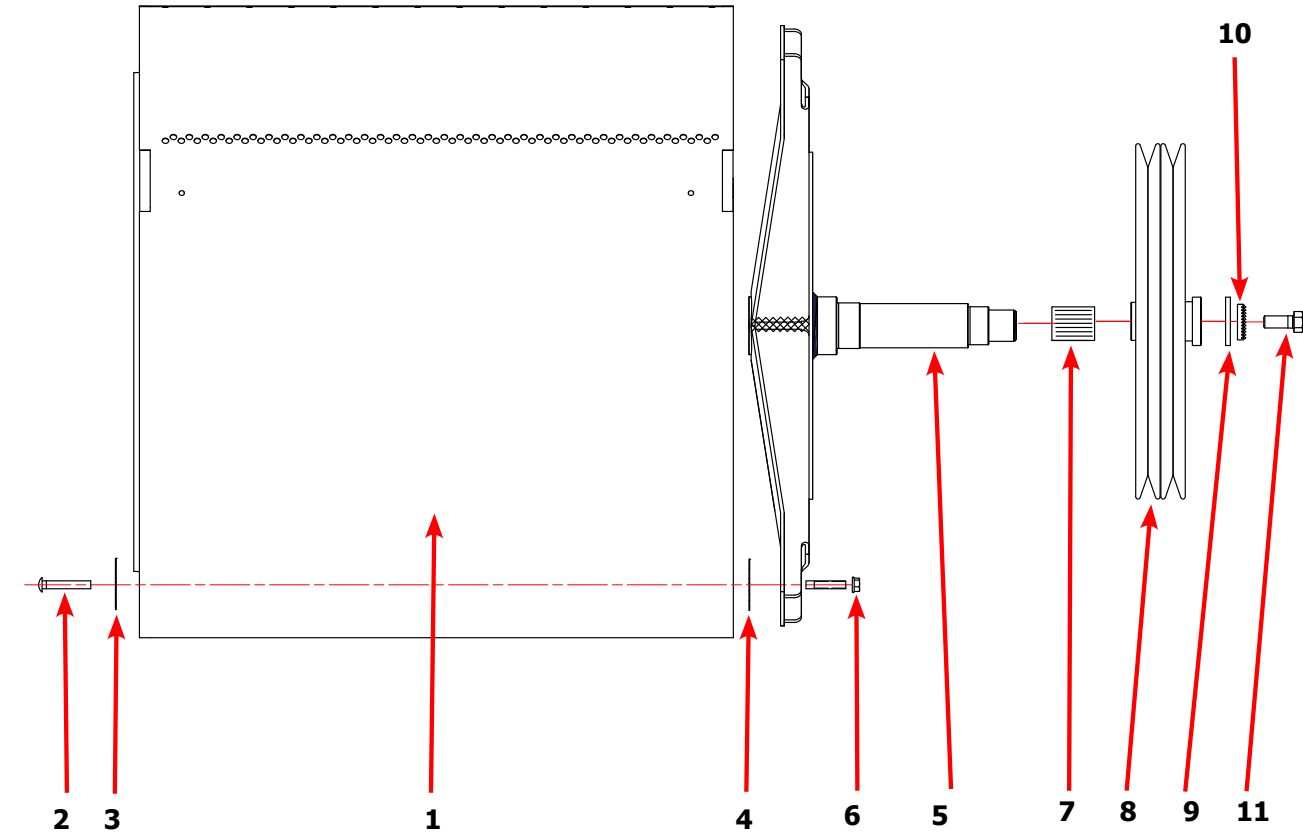

Key	Description	T-120	QTY
*	Tumbler Assy Complete W/Spider (GALV)	9848-160-001	1
1	Tumbler Assy (Galvanized)	9848-159-001	1
2	Rod, Tumbler	9497-266-003	4
3	Plate support, Tie Rod	9452-805-001	4
4	Shim	9552-013-003	AR
5	Spider Assy	9568-016-001	1
6	Nut, Wiz Lock	8640-417-005	4
7	Tolerance Ring	9487-234-006	1
8	Pulley, Driven	9453-168-003	1
9	Washer -Flat	8641-581-032	1
10	LockWasher - IntTooth, 1"	8641-582-018	1
11	Screw, 5/8-11 x 1 1/2"	9545-060-001	1

Dryer Burner Housing Group 120Lb

Key	Description	T-120	QTY
*	Housing Assembly, Burner	9803-213-001	1
1	Screw, 10ABx3/8	9545-008-024	58
2	Bracket-Support, Gas Valve	9029-240-001	1
3	Side-Extention Baffle, Burner Housing	9551-049-001	2
4	Burner, Main	9048-022-001	3
5	Baffle-Burner Housing, Extension	9049-105-001	1
6	Panel-Burner Housing, Front	9454-882-001	1
7	Panel-Burner Housing, Back	9454-883-001	1
8	Panel-Burner Housing, Side Left	9551-052-001	1
9	Baffle-Center, Burner	9049-106-001	1
10	Panel-Burner Housing, Side Right	9551-051-001	1
11	Channel-Burner Housing, Right	9081-164-001	1
12	Bracket-Manifold	9029-239-001	1
13	Bracket-Support, Burner, Front	9029-241-001	1
14	Bracket-Support, Burner, Rear	9029-242-001	1
15	Control Assy,Gas Valve, White Rodgers 36J	9857-193-001	1
16	Manifold Assy	9381-013-001	1
17	Top Assembly, Burner Housing	9961-161-001	1
18	Screw, 10Bx1/4	9545-008-001	18
*	Orfice-Natural, #10	9425-069-027	3
*	Orfice-LP, #32	9425-069-009	3
*	Kit, LP Conversion, White Rodgers	9732-102-025	1
19	Thermostat-HI-Limit	9576-203-002	1
20	Electrode-Ignition	9875-002-003	1
21	Bracket-Igniter	9029-243-001	1
22	Elbow-3/4 Street, Black	8615-104-042	1
23	Pipe-Nipple, 3/4 x 4", Black	8655-073-046	1
24	Valve-Gas Shutoff,	9379-198-001	1
25	Deflector-bottor,air	9114-055-001	1

Dryer Burner Housing Group 120Lb

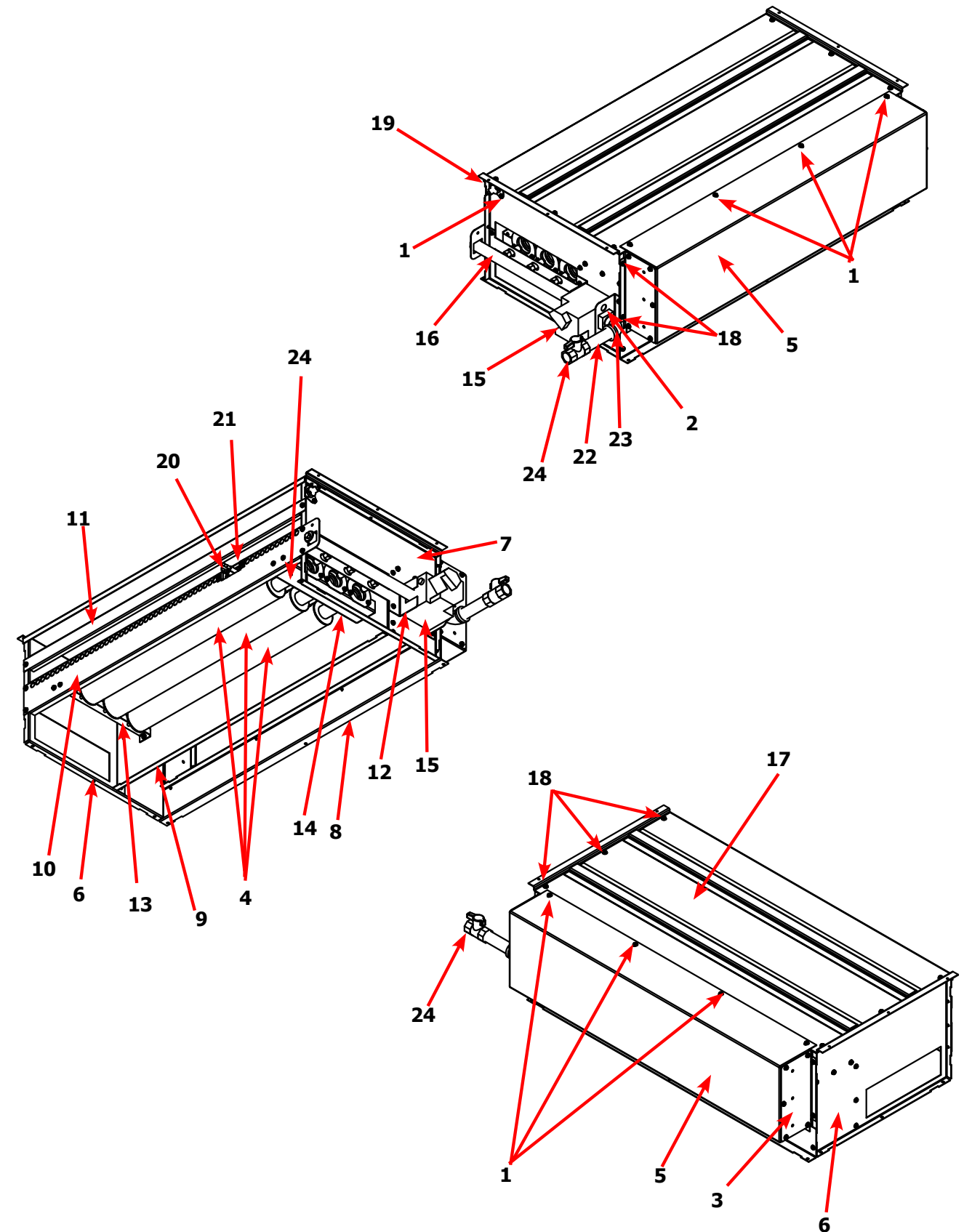

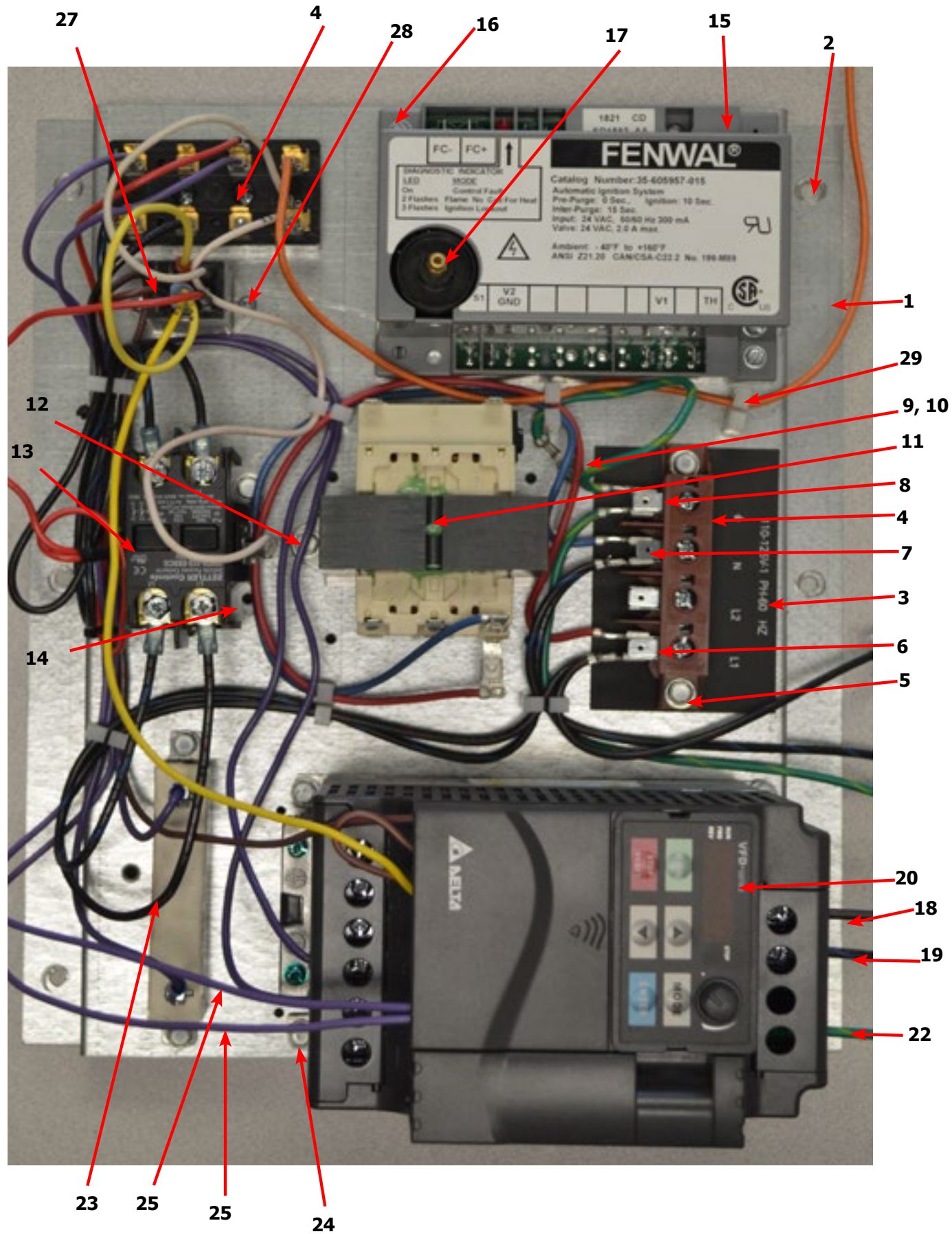

Dryer Rear View-Control Box

Key	Description	T-120	QTY
*	Cntlasy-cmpl,t-120coin,60hz	9857-261-001	1
1	Channel-Controls	9081-163-001	1
2	Screw, 5/16-10AB-3/8	9545-008-026	6
3	Strip-Marker, Terminal	9558-029-005	1
4	Terminal Block Assy-Power, 4Pole	9897-035-001	1
5	Screw, 5/16-10AB-3/8	9545-008-024	2
6	Wireasy-blk/red, 15.5"	8220-095-051	1
7	Wireasy-blk/blu, 15.5"	8220-095-052	1
8	Wireasy-grn/ylw, 7'	8220-137-002	1
9	Screw- 10-32TTx1/2 GRN	9545-008-027	2
10	Lockwasher, External tooth	8641-582-006	2
11	Transformer, w/Circuit breaker	8711-007-002	1
12	Screw, 5/16-10AB-3/8	9545-008-024	2
13	Relay-Motor, 30Amp, 24VAC	5192-299-002	1
14	Screw, 5/16-10AB-3/8	9545-008-024	2
*	Wire assy-Blk/Red, 15"	8220-146-003	2
*	Wire assy-Blk/Blu, 15"	8220-146-004	2
15	Control Assy, Ignition (Module)	9857-182-001	1
16	Screw-8Bx3/4"	9545-045-005	2
*	Harness, Ignition Module	9627-867-004	1
17	Wire Assy- High Voltage Lead	9631-403-005	1
18	Wire Assy-Jumper.red16-9"	8220-097-004	1
19	Wire Assy-White, 12"		1
20	Drive-vf,deltae,t-120, coin	9375-031-008	1
PS	Key Pad, Delta E-Drive	9150-044-001	1
21	Screw-#10B x 1/2	9545-008-026	4
22	Wire Assy-Green, 18"	8220-092-006	1
*	Wire Assy, Brown 3"	8220-057-035	1
23	Resistor-Dynamic Breaking, 2000HM	9483-004-002	1
24	Screw-5/16, 10ABx3/8	9545-008-024	2
25	Wire Assy, Violet 8"	8220-118-003	2
			1
27	Relay, 24VAC	5192-285-004	1
28	Screw, 6B x 3/8		4
*	Wire Assy-BLK/BLU, 15"	8220-150-002	1
*	Wire Assy-BLK/RED, 12"	8220-150-001	1
*	Harness, Control	9627-859-005	1
29	Stand off	9527-007-002	7

Dryer Air Flow Switch Assembly

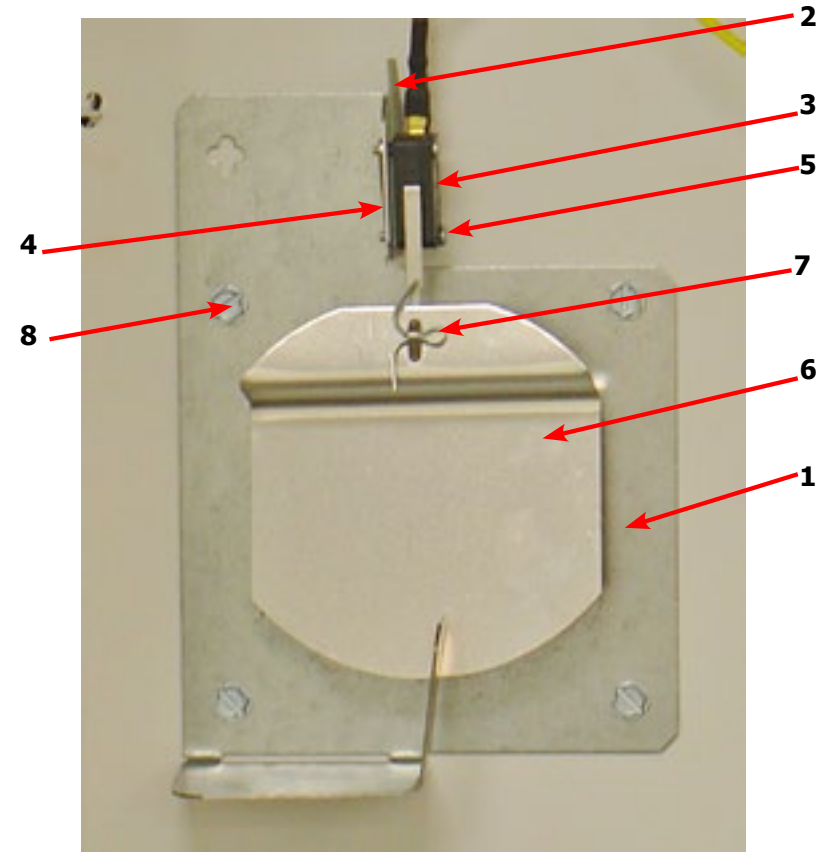

Key	Description	T-120	QTY
*	Air Flow switch Assy	9801-098-001	1
1	Bracket-Airflow switch	9029-200-001	1
2	Shield-Switch	9550-169-003	1
3	Switch-Micro	9539-461-009	1
4	Nut-Twin, 4-40	8640-401-001	1
5	Screw-.625, 4-40	9545-020-001	2
6	Actuator-Air Flow Switch	9008-007-001	1
7	Pin-Cotter, .09375x.75	9451-169-002	1
8	Screw, 10Bx1/4	9545-008-024	4

Dryer Coin Switch Assembly

Key	Description	T-120	QTY
1	Optical Coin Acceptor	9021-094-001	1
2	Replacement Optical Sensor	9801-099-003	1
3	Retainer-Coin Acceptor	9486-149-001	2
4	Screws-Torq, 4Bx5/8 ss	9545-053-002	4

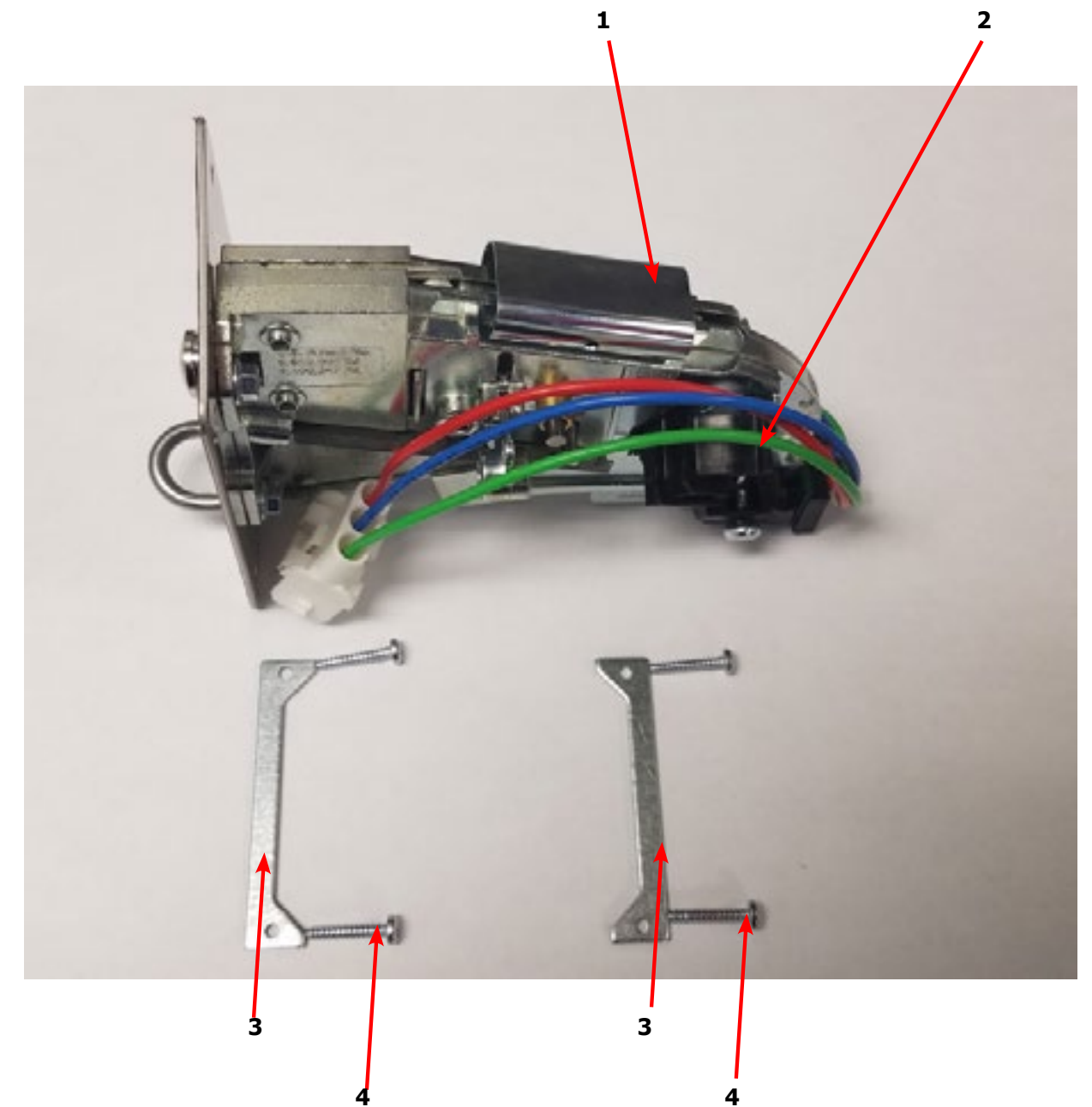

Wiring Diagram for 60hz Dryer -10BD

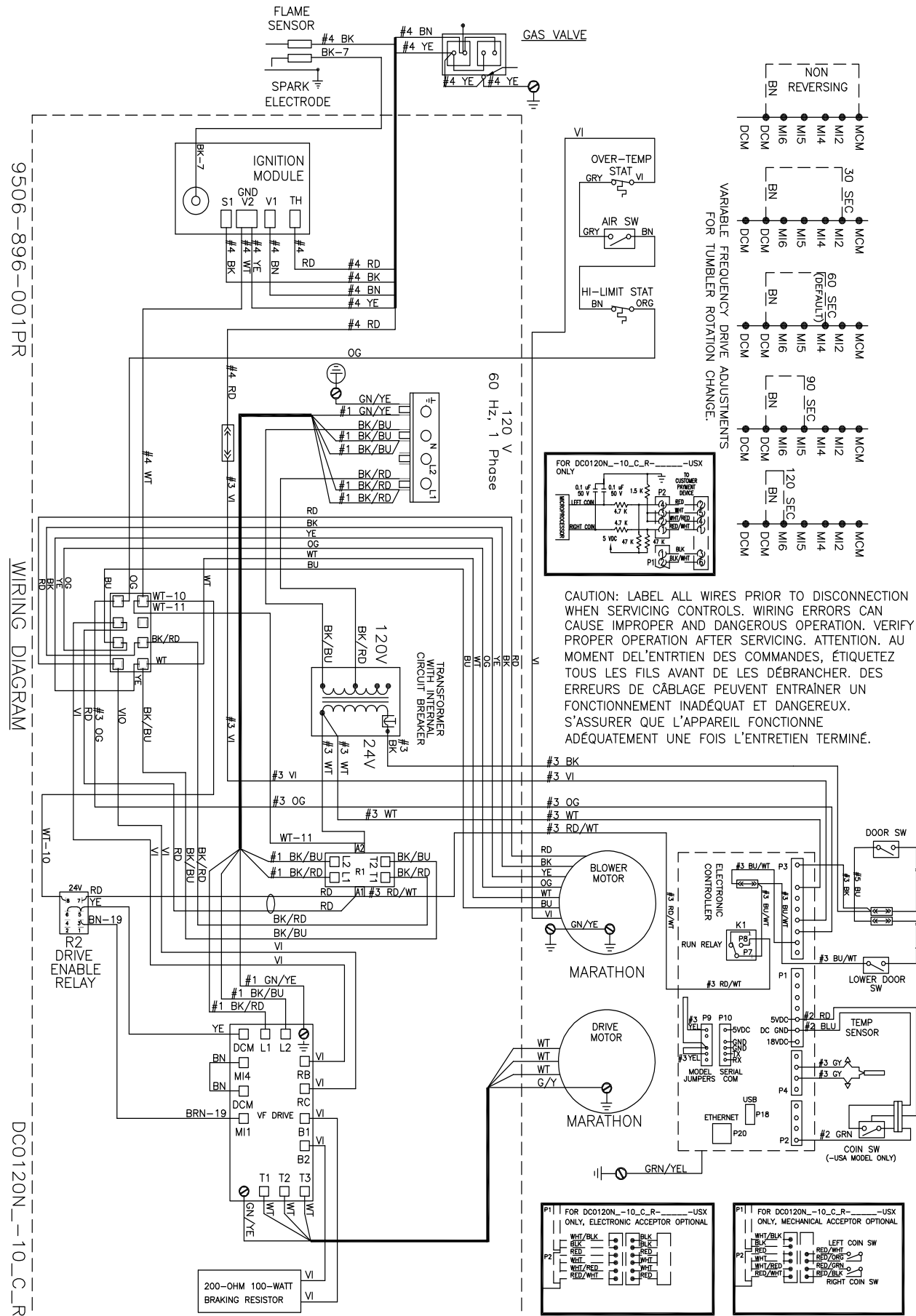

Wiring Schematic for 60hz Dryer -10BD

