



Section: 6

Dryer Parts Data

SWD

Kits, Assemblies, & Common Parts

Description	Part Number	QTY
LINER-BAFFLE,RIGHT(DDAD30),PTD	9354-011-002	
LINER-BAFFLE,LEFT(DDAD30),PTD	9354-012-002	
Kit - Make-Up Air, T-30 SWD	9732-333-001	
Kit - 9568-015-001 w/ bearings & tolerance ring	9732-330-001	
Emergency Stop Button Kit w/ button & switch Assy	9732-223-002	
LP to Natural Conversion Kit for White Rodgers	9732-142-004	
Kit - 8650-012-004 Lock with spacer	9732-344-002	
Temperature Probe	9501-010-001	
Controls Blue	9857-199-002	
Controls Black	9857-199-004	
Ignition Control Box	9857-182-001	
Electrode Assembly	9875-002-003	
Hi-Limit Thermostat	9576-203-002	
Overtemp Thermostat	9576-207-008	
Fuseholder	9200-001-002	
Fuse	8636-018-001	
Relay	5192-299-002	
Transformer	8711-007-002	
Lint Screen without Front	9805-029-002	
Airflow Switch	9539-461-009	
Door Switch	9539-487-001	
Motor Belt	9040-077-001	
Tumbler Belt	9040-073-009	
Tension Arm Complete Assembly	9861-022-001	
Spider/Trunnion	9568-015-001	
Door Handle	9244-093-001	

Dryer Cabinet Group

	Description	T-30 SWD	QTY
1	Panel Assy., Front- Upper (SS)	9989-603-001	1
*	Insulation Front Panel, half moon (top)	9277-063-001	1
*	Insulation Front Panel, half moon (bottom)	9277-063-002	1
2	Screw, FLHDCR, 10B x- 1 3/4	9545-008-014	4
3	Washer, Finish, #10	8641-585-001	4
*	Nut, Spring	8640-442-001	4
*	Hinge ,Backup Plate	9982-386-001	1
*	Screw, Countersink, 10-32X 1/2	9545-012-003	2
4	Strap, Hinge (SS/Black)	9544-072-002	2
*	Screw, Hinge to Panel	9545-012-028	4
*	Door Assy., Loading Complete-SS	9960-256-039	1
*	Door Assy., Loading Complete-Chrome/BLK/SS	9960-256-035	1
5	Door Assy., Loading-SS(ring only)	9960-255-008	1
5	Door Assy., Loading-Chrome(ring only)	9960-255-016	1
6	Plate Assy., Hinge (SS)	9982-280-012	1
*	Screw, Hinge to Door	9545-012-015	4
*	Nut, Hinge to Door	8640-413-002	4
*	Cover, Hinge Plate	9074-341-002	1
*	Screw, Phillips-10B x 3/8	9545-008-010	2
7	Glass, Door	9212-002-003	1
8	Gasket, Glass Black	9206-413-001	1
*	Support, Door Glass	9548-117-000	1
*	Tool Install Dryer Door Gasket	8545-064-001	1
9	Gasket, Outer Rim Black	9206-420-003	1
10	Handle, Loading Door	9244-093-001	1
*	Screw, Handle 1/4-20 x 3/8	9545-018-017	2
11	Stud, Door Catch, 3/4	9531-033-002	1
12	Nut, Hex	8640-413-001	1
13	Nut, Acorn	8640-413-003	1
14	Catch, Loading Door	9086-015-002	1
15	Pop Rivet for mtg. catch	8638-190-009	2
16	Screw, Door to Hinge Strap (Special Black Type)	9545-052-001	1
17	Washer, Fiber	8641-436-003	1
*	Cabinet Touch Up Paint (White)	9472-001-013	1

Cabinet Group

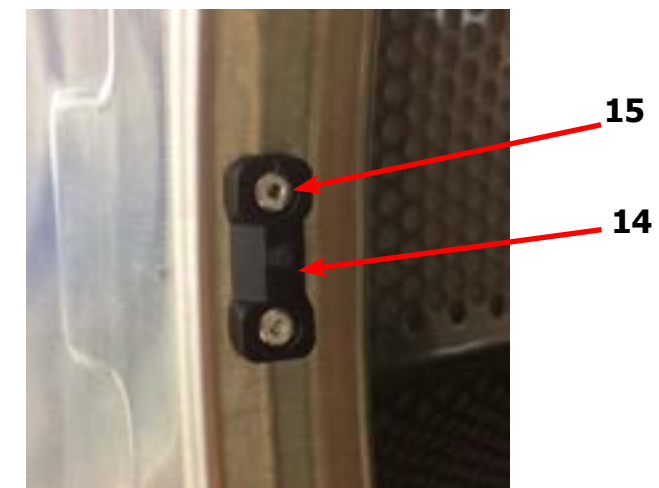
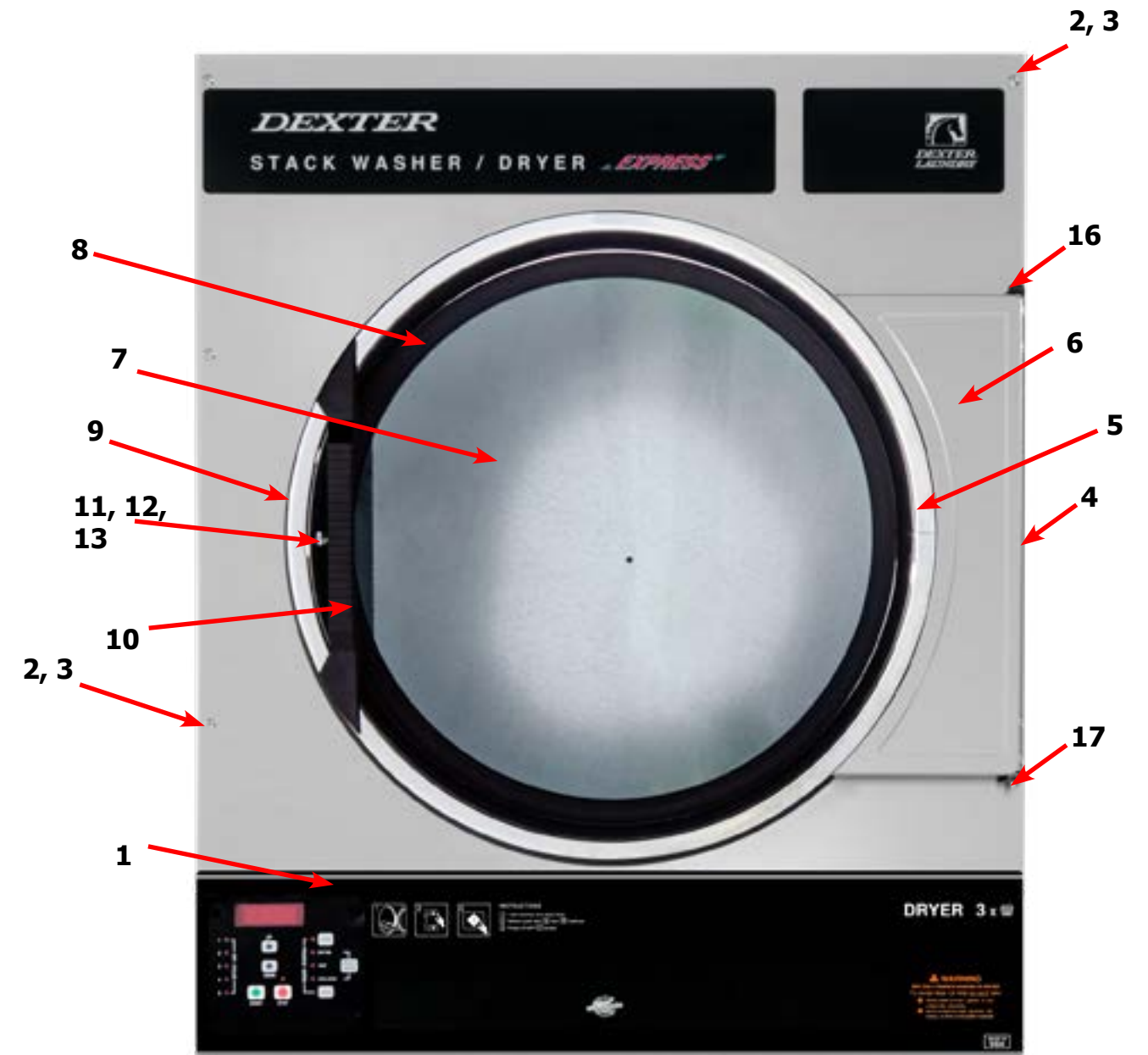

Dryer Cabinet Group

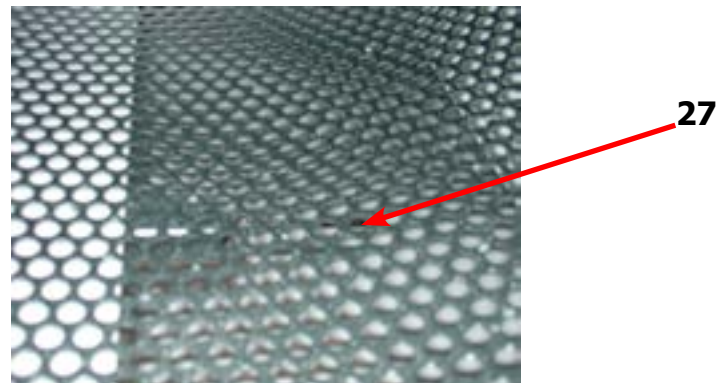

Cabinet Group Continued

Key	Description	T-30 SWD-11	QTY
20	Escutcheon, SWD, Dryer opl	9994-042-001	1
21	Trim, Overlay-Upper Black	9435-056-001	1
*	Screw, #4-40 x 3/16	9545-020-009	12
22	Nameplate Stack Dryer Express Black	9412-202-001	1
*	Lint Drawer Assembly Black	9866-004-013	1
*	Drawer, Front PTD	9974-010-001	1
*	Washer, Flat, #10	8641-581-006	2
*	Washer, Curved-Spring	8641-569-004	2
*	Nut, 10-32	8640-413-007	2
23	Overlay Trim, Lint Drwr-Black	9435-029-002	1
*	Felt Seal (back of lint screen assembly)	9555-057-002	1
*	Lint Screen Assembly ONLY (no front)	9805-038-001	1
*	Replaceable Lint Screen Only	9555-057-002	1
24	Lock-Door Service Thumb Turn	8650-026-002	1
*	Cam, Lock	9095-044-001	1
*	Lint Screen Strap Hold Down Screws 10Bx 1/4	9545-008-001	32
25	Controls Assy, 24VAC, Black	9857-227-001	1
*	Harness, Electronic Control	9627-770-005	1
*	Screw-trhdtorx 6bsd1/2blk	9545-031-009	4
*	Harness, Heat Sensor	9627-679-003	1
*	Wire Nut Connector Grey	8640-276-002	2
27	Sensor Temp/Bracket Control	9501-010-002	2
*	Cover, Cabinet (Top)	9074-365-001	1
*	Insulation Cabinet Cover	9277-041-011	1
*	Screw-hxwshrundrcuthd,10abx3/8	9545-008-024	14
*	Stack Dryer Trunnion Puller	9732-243-002	1

Dryer Modular Cabinet Group (After Serial D1.23283.027)

Key	Description	T-30 SWD	QTY
*	Cabinet Base Assembly	9945-169-002	1
*	Back Panel Assembly	9989-739-002	1
*	RH Side Panel Assembly	9444-121-003	1
*	LH Side Panel Assembly	9444-121-004	1
*	RH Lint Rail Guide Assembly	9750-025-001	1
*	LH Lint Rail Guide Assembly	9750-026-001	1
*	Lower Baffle Brace	9046-106-001	1
*	RH Baffle	9049-131-001	1
*	LH Baffle	9049-132-001	1
*	Baffle Angled Bracket	9029-371-001	2
*	Baffle Reinforcement	9489-059-001	3
*	Baffle Reinforcement with Thermistor Mount	9489-060-001	1
*	Heat Chamber Assembly	9870-102-001	1
*	Heat Chamber Bracket	9029-373-001	1
*	Upper Cross Brace	9046-107-001	1
*	Cabinet Top Cover	9074-365-001	1
*	10abx3/8 Screw	9545-008-024	1
*	3/16 Blind Rivet	9491-009-001	98
*	Wht 3/16 Blind Rivet	9491-009-005	26

Dryer Back Panels and Guards

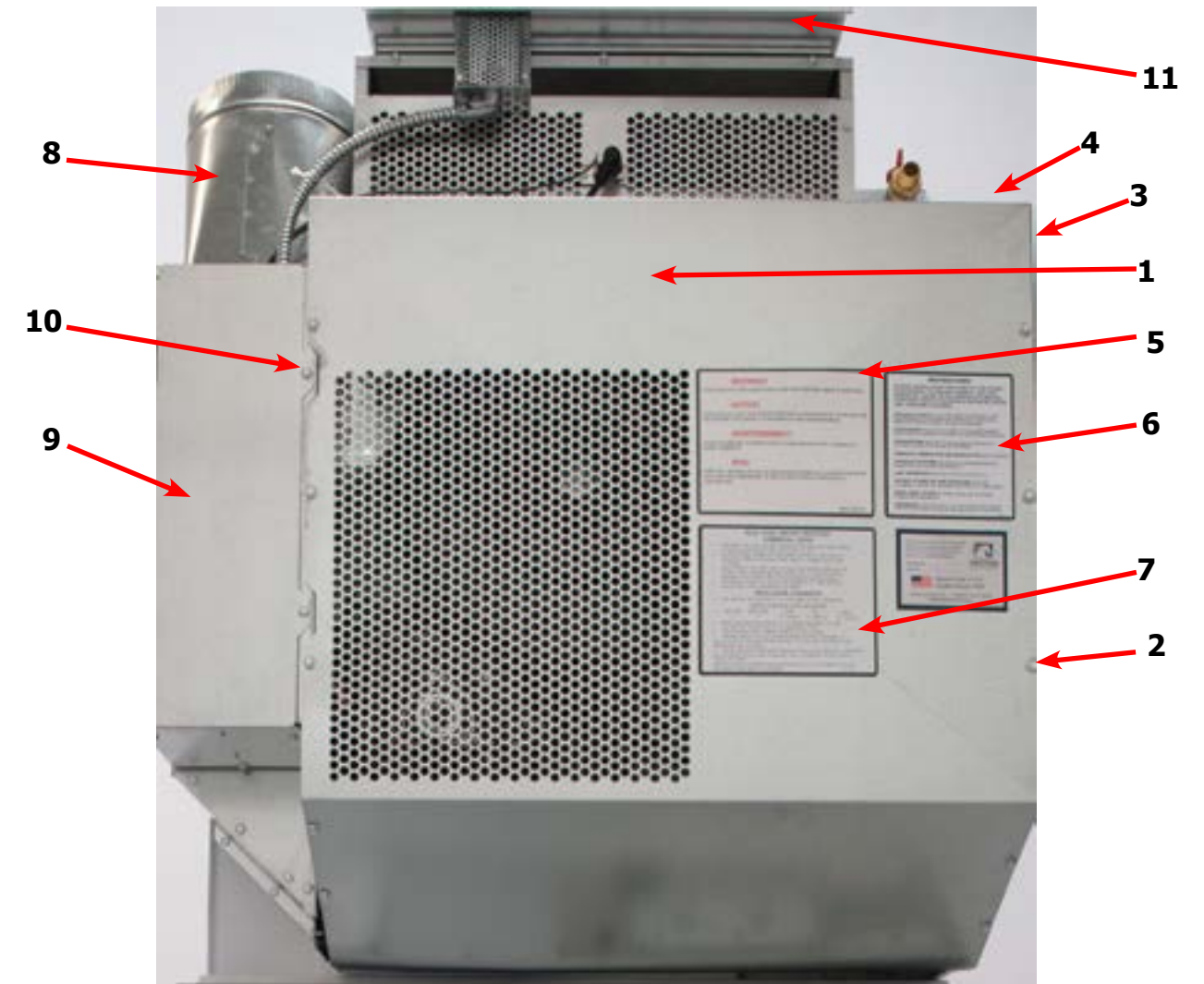

Key	Description	Part Number	Qty
1	Guard, Drive	9208-124-001	1
2	Screw, 10AB x 3/8	9545-008-024	18
3	Panel, Drive Guard,	9208-123-001	1
4	Guard-Small, upper	9208-074-001	1
5	Warning, Label	8502-763-001	1
6	Label, Instructions	8502-645-001	1
7	Lighting and Clearance, Label	8527-112-001	1
8	Duct, Transition	9109-129-001	1
9	Door, Cover-Control Box	9108-141-001	1
10	Guard Side, RH	9208-141-001	1
*	Cabinet, Cover	9074-365-001	1
*	Insulation	9277-041-011	1
11	Shield-Burner Inlet	9550-173-001	1
*	Wiring Diagram & Schematic	9506-830-001	1
*	6" Slide Open Clean Out Duct (Optional0	9973-035-001	1

Air Flow Switch Assembly

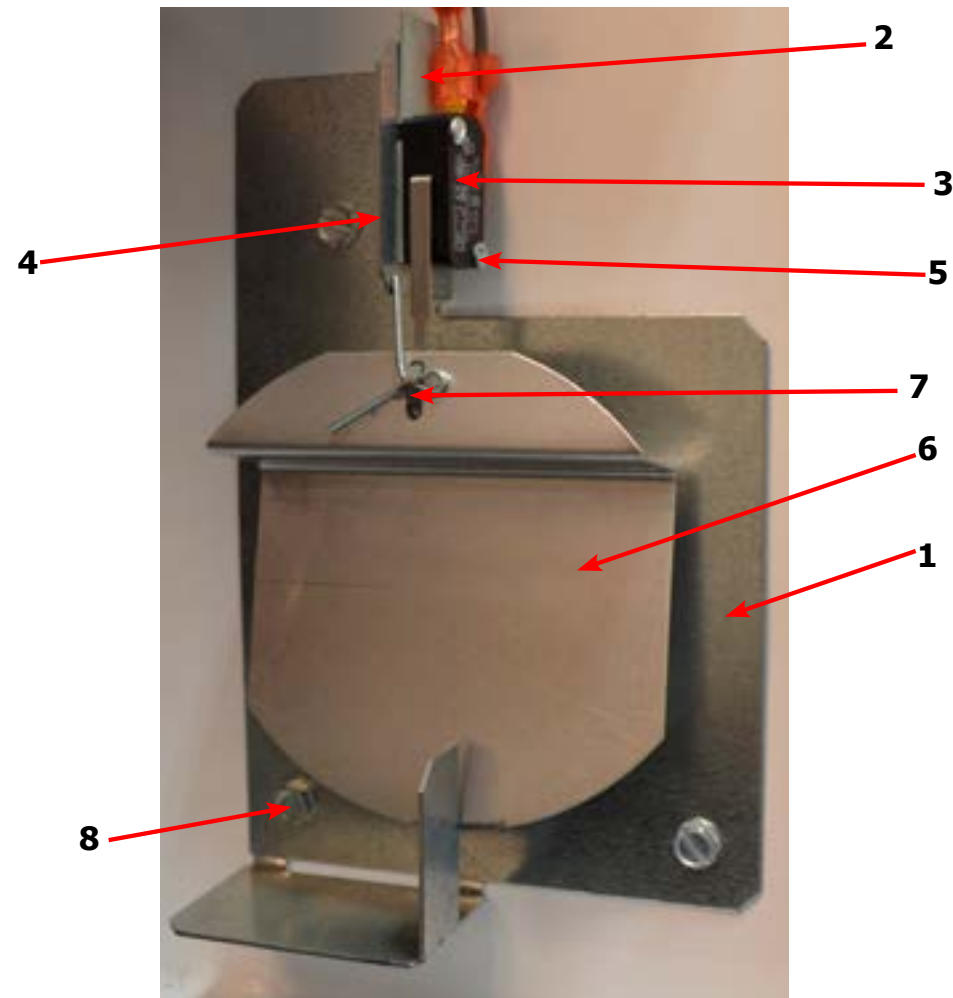

Key	Description	T-30 SWD	QTY
*	Air Flow switch Assy	9801-095-001	2
1	Bracket-Airflow switch	9029-174-001	2
2	Shield-Switch	9550-169-003	2
3	Switch-Micro	9539-461-009	2
4	Nut-Twin, 4-40	8640-401-001	2
5	Screw-.625, 4-40	9545-020-001	2
6	Actuator-Air Flow Switch	9008-007-001	2
7	Pin-Cotter, .09375x.75	9451-169-002	2
8	Screw, 10BX x 1/4	9545-008-01	3
*	Harness Assembly, Overtemp/Airflow	9627-861-001	1

Dryer Burner Housing Group

Key	Description	T-30 SWD	QTY
*	Housing Assembly, Burner (All sheet metal parts not listed)	9803-229-003	1
1	Service Burner Plate Front	9452-730-001	1
2	Screw, 10B X 1/4"	9545-008-001	4
3	Service Plate baffle Recirculation Chamber Clean Out	9452-850-001	1
4	Screw, 10B x 3/8"	9545-008-006	6
5	Angle, Burner Support	9003-220-001	1
*	Screw, 10B x 3/8"	9545-008-006	2
6	Burner, Main	9048-020-001	2
*	Screw 10AB x 3/8"	9545-008-006	2
*	Panel, Back Burner Housing	9454-991-001	1
7	Electrode Assy, Ignition	9875-002-003	1
8	Screw, Electrode Mtg 8B x 1/4"	9545-045-001	2
9	Valve, Gas Shut Off (Optional)	9379-196-001	1
10	Pipe, 1/2 x 4 1/2, BLK	8655-073-044	1
11	Elbow, 1/2 x 90, BLK	8615-104-037	1
12	Nipple, 1/2 x 4 1/2, BLK	8665-073-008	1
13	Control Assy, Gas	9857-134-001	1
14	Manifold, Assy	9029-175-001	1
*	Orifice, Burner-Natural #32	9425-069-009	2
*	Orifice, Burner-LP #50	9425-069-008	2
15	Bracket, Manifold	9029-175-001	2
16	Pipe Plug in end of Burner Manifold	8615-104-038	1
*	Screw, 10AB x 3/8"	9545-008-006	2
*	Bracket, High Limit Thermostat	9029-192-001	1
17	Thermostat, Hi-Limit	9576-203-002	1
*	Spacer, Hi-Limit	9538-142-001	2
*	Screw 8B x 3/4"	9545-045-007	2
18	Cover, Hi-Limit Stat	9074-329-001	1
*	Screw, 10AB x 3/8"	9545-008-006	2
19	Thermostat, Safety Shutoff	9576-207-008	1
20	Screw, 10AB x 3/8"	9545-008-006	2
21	Cover, Safety Stat	9825-062-001	2
*	Screw, 10AB x 3/8	9545-008-006	3
*	Control, Ignition Fenwall (3 trybox)	9857-182-001	1
*	Kit, LP Conversion	9732-102-036	1
22	Heat Recirculation Duct, (From Exhaust to Burner	9973-033-001	2
*	Screw, 10AB x 3/8"	9545-008-006	8
23	Shield-Burner Inlet	9550-173-001	1
*	Make-Up air Vent Kit	9732-333-001	1

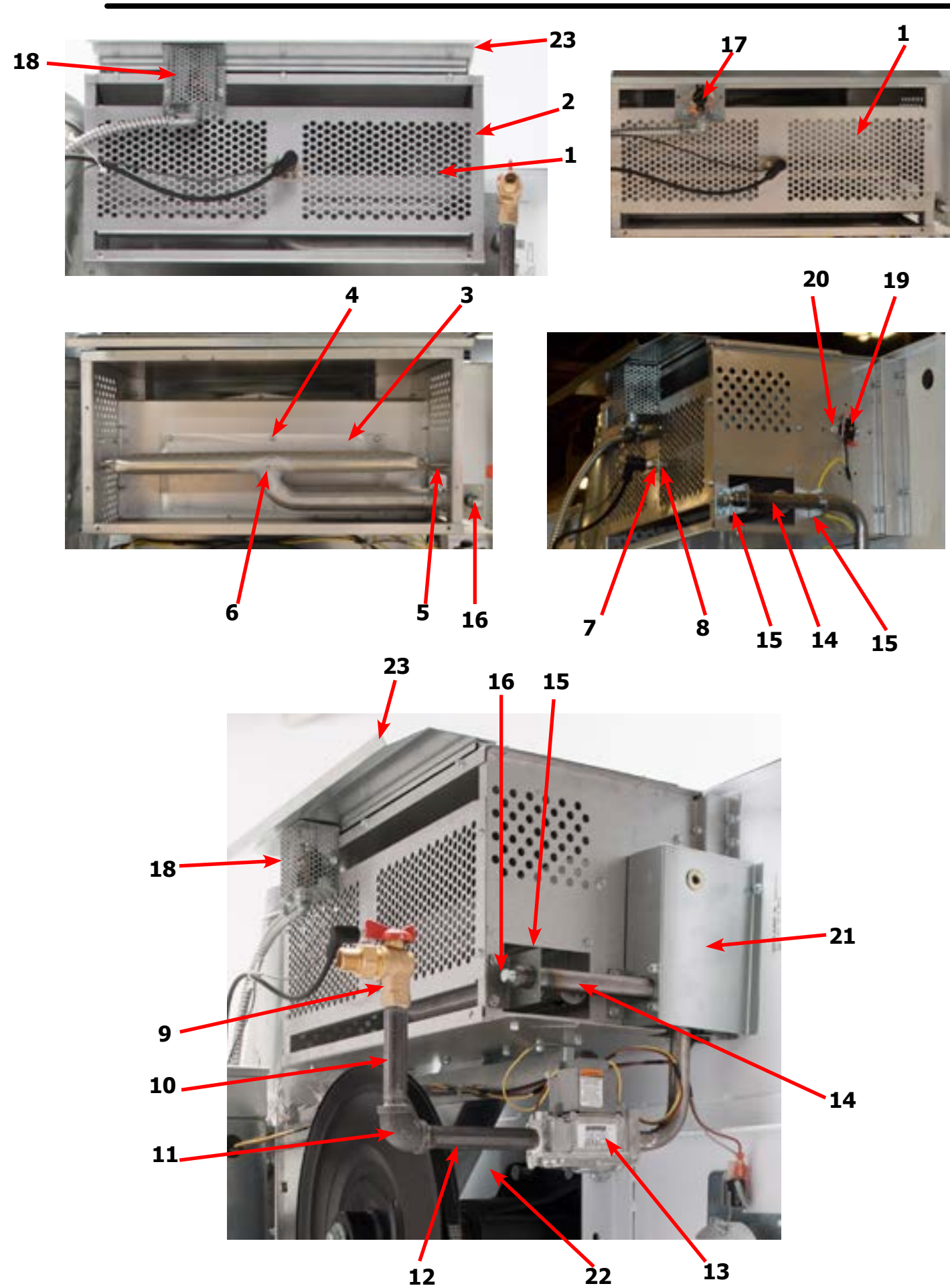

Bearing Housing Group

Key	Description	T-30 SWD	QTY
	Bearing Housing Complete Assy (Includes bearings & Spacer)	9803-160-003	1
1	Housing, Bearing	9241-161-002	1
*	Spacer, Bearing	9538-139-002	1
2	Bearing, Ball, Front & Rear	9036-130-001	2
3	Screw-Wizlock, 3/8-24x3/4	9545-049-002	4
4	Nut, 5/16-18	8640-400-002	4
5	Screw, 3/8-24x1	9545-049-001	2
6	Nut, 3/8-24	8640-415-002	2

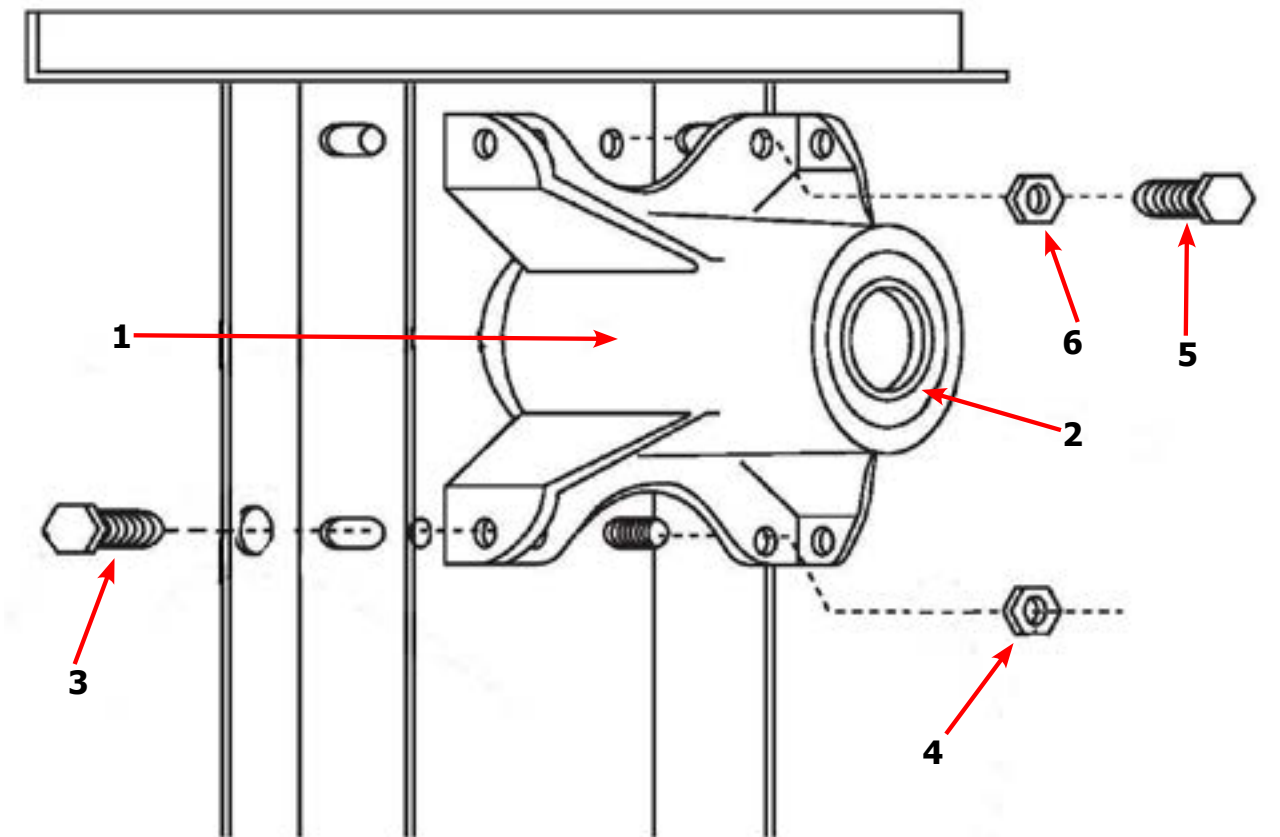

Tumbler Group

Key	Description	T-30 SWD	QTY
*	Tumbler Assy Complete W/Spider (GALV)	9848-147-001	1
1	Tumbler Assy (Galvanized)	9848-146-001	1
*	Tumbler Assy Complete W/Spider (SS & Galv front)	9848-147-002	1
1	Tumbler Assy (Stainless Galvanized front)	9848-146-002	1
2	Rod, Tumbler	9497-019-003	3
3	Washer, Special	8641-554-001	3
4	Shim	9552-013-003	AR
5	Spider Assy	9568-015-001	1
6	Nut, Wiz Lock	8640-415-004	3
7	Spacer-Shaft	9538-164-002	1
8	Tolerance Ring	9487-234-005	1
9	Pulley, Driven	9908-049-002	1
10	Washer -Flat 1/2	8641-581-026	1
11	LockWasher - IntTooth, 1"	8641-582-016	1
12	Screw, 1/2-13x1 1/4	9545-017-009	1
*	Belt, Drive	9040-073-009	2

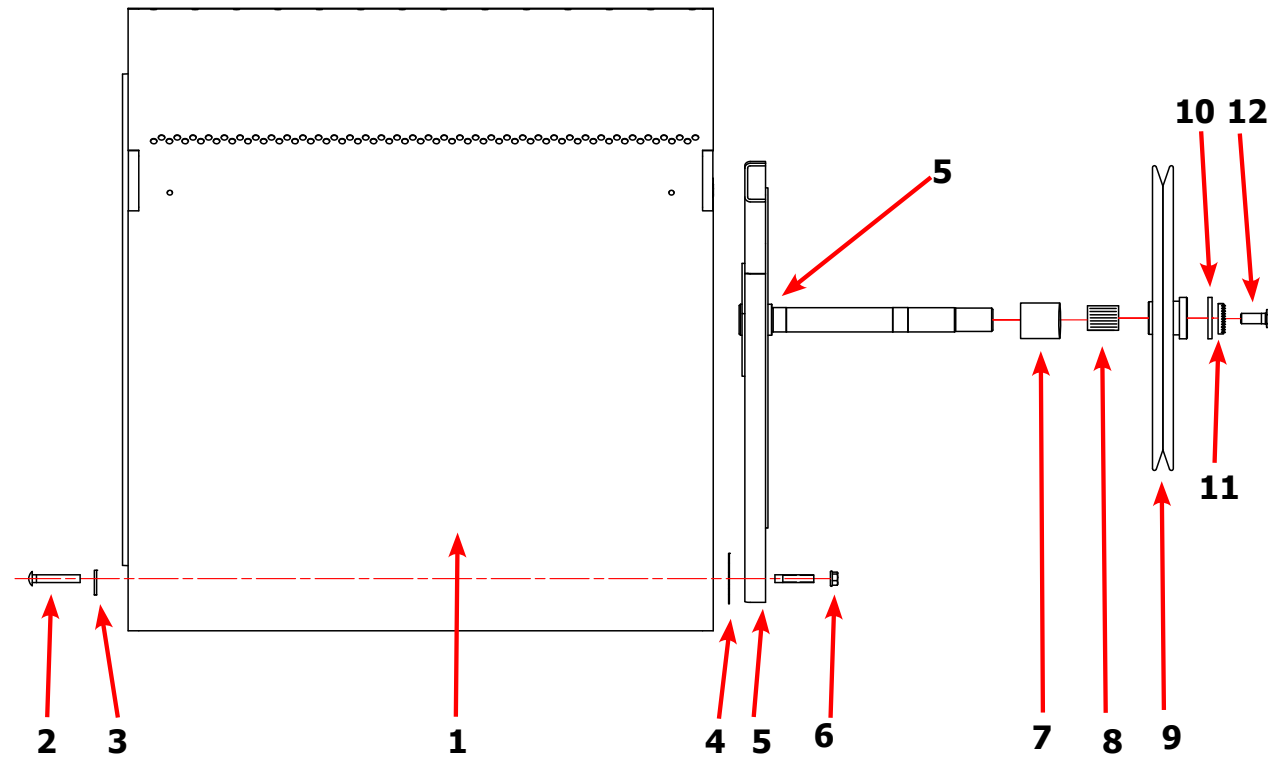

Key	Description	T-30 SWD	QTY
*	Wire Harness Overtemperature Switch	9627-861-001	1
*	Switch Assy, Air Flow	9801-095-001	1
1	Switch, Air Flow	9539-461-009	1
2	Bracket, Switch- Air Flow	9029-174-001	1
3	Actuator, Switch	9008-007-001	1
4	Pin, Cotter	9451-169-002	1
5	Screw 4-40 x 5/8"	9545-020-001	2
*	Nut, Special Twin .#4-40	8640-401-001	1
*	Shield, Switch	9550-169-003	1
*	Screw 10 Bx 1/4"	9545-008-001	3
7	Motor, Drive	9376-331-001	1
*	Tumble Capacitor	5191-108-002	1
*	Start Capacitor	5191-109-002	1
8	Plate, Motor Mtg	9452-740-001	1
*	Bolt 3/8" - 16 x 3/4"	9545-029-008	1
*	Lockwash Spring 3/8	8641-582-003	1
9	Screw, Motor Plate to Back Assy. 1/4-20x 2 1/2	9545-018-019	1
9	Lockwasher 1/4	86411-582-007	1
9	Spacer	9538-163-006	1
9	Flat Washer 1/4 x 7/8.	8641-581-017	1
9	Rubber Grommet	9209-086-002	1
*	Grommet Spacers	9538-166-006	1
*	Screw, Set	9545-028-013	1
10	Back Assy, Blower Hsg	9962-017-002	1
*	Nut 1/4x20	8640-414-004	7
*	lock washer	8640-582-007	7
*	Clamp-cable, 3/4	8654-126-004	2
*	Screw-hxhdsltdmach, 12abx1/2	9545-048-001	2
11	Support Assy, Intermed. Pulley	9991-053-001	1
12	Bolt, Rd Hd 3/8-16 x 1 1/4	9545-029-010	3
13	Bolt, 3/8-16 x 1 1/2	9545-029-003	1
12	Nut Flange Wizioc 3/8" - 16	8640-415-004	3
*	Washer, Flat	8641-581-035	1
14	Arm Assy-Tension, Complete	9861-022-001	1
*	Washer, Flat	8641-581-035	1

Rear View Photos

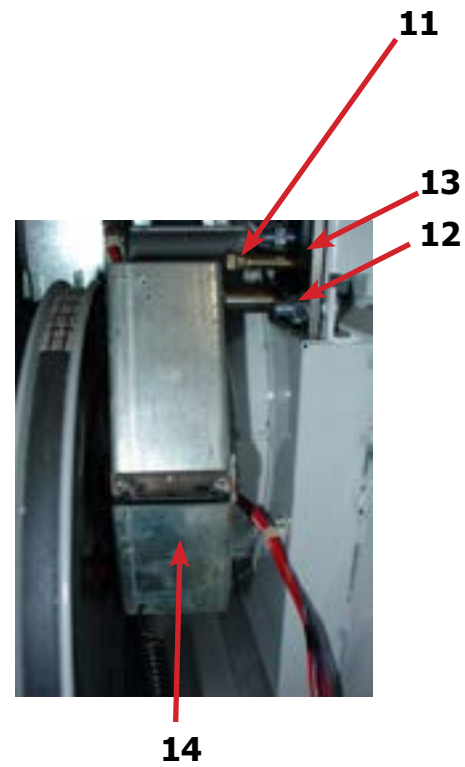
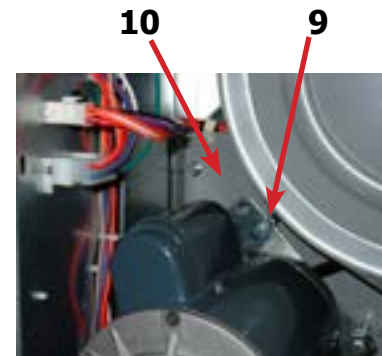
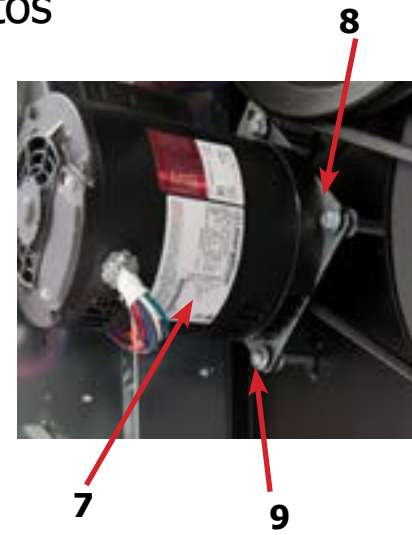
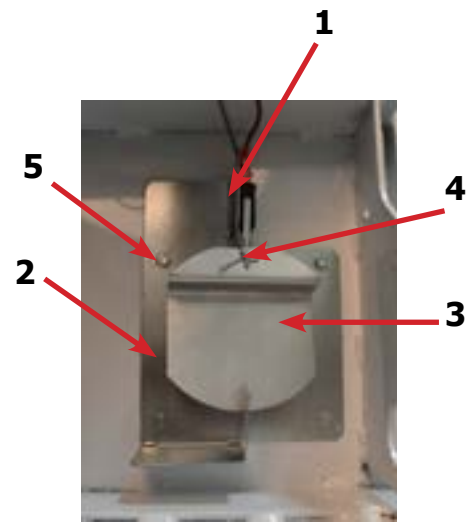

Key	Description	T-30 SWD	QTY
14	Arm Assy-Tension, Complete	9861-022-001	1
*	Washer, Flat	8641-581-035	1
15	Ring-Retaining	9487-200-003	1
16	Pulley Assy, Intermediate with bronze flange bearing	9908-039-004	1
*	Bearing - Bronze Flange	9036-145-002	1
*	Spacer-Shaft (See Tumbler Group for Expanded View)	9538-164-002	1
*	Tolerance Ring	9487-234-005	1
17	Pulley, Driven	9908-049-002	1
18	Washer -Flat	8641-581-026	1
18	LockWasher - IntTooth, 1"	8641-582-016	1
18	Screw, 1/2-13x1 1/4	9545-017-009	1
19	Belt, Drive- Motor	9040-077-001	1
20	Belt, Drive- Tumbler	9040-073-009	1
21	Spring, Tension	9534-319-002	1
22	Chain, Tension	9099-012-002	1
23	Hook, Tension	9248-,022-002	1
*	Damper Inside Duct Exhaust	9125-007-002	1
24	Pin, Damper Hinge	9451-146-001	1
*	Nut, Spring	8520-141-000	2
*	Screw #10B x 1/2	9545-008-026	3
*	Cover Duct Upper	9825-380-001	1
*	Base Duct	9047-118-001	1
*	Screw 10ABx 3/8"	9545-008-024	40
26	Impeller, W/Set Screws	9278-040-001	1
27	Pulley, Motor	9453-157-001	1
25	Heat Recirculation Assembly Duct	9973-033-001	1
*	Bracket for Wire Harness Under Burner Housing	9029-173-001	1

Rear View Photos



14



17

18

19

20

15

16



21

22

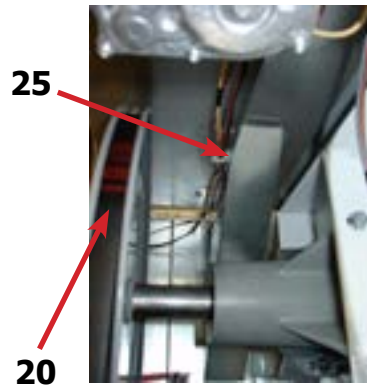

25

20



26



27

Control Assembly Group

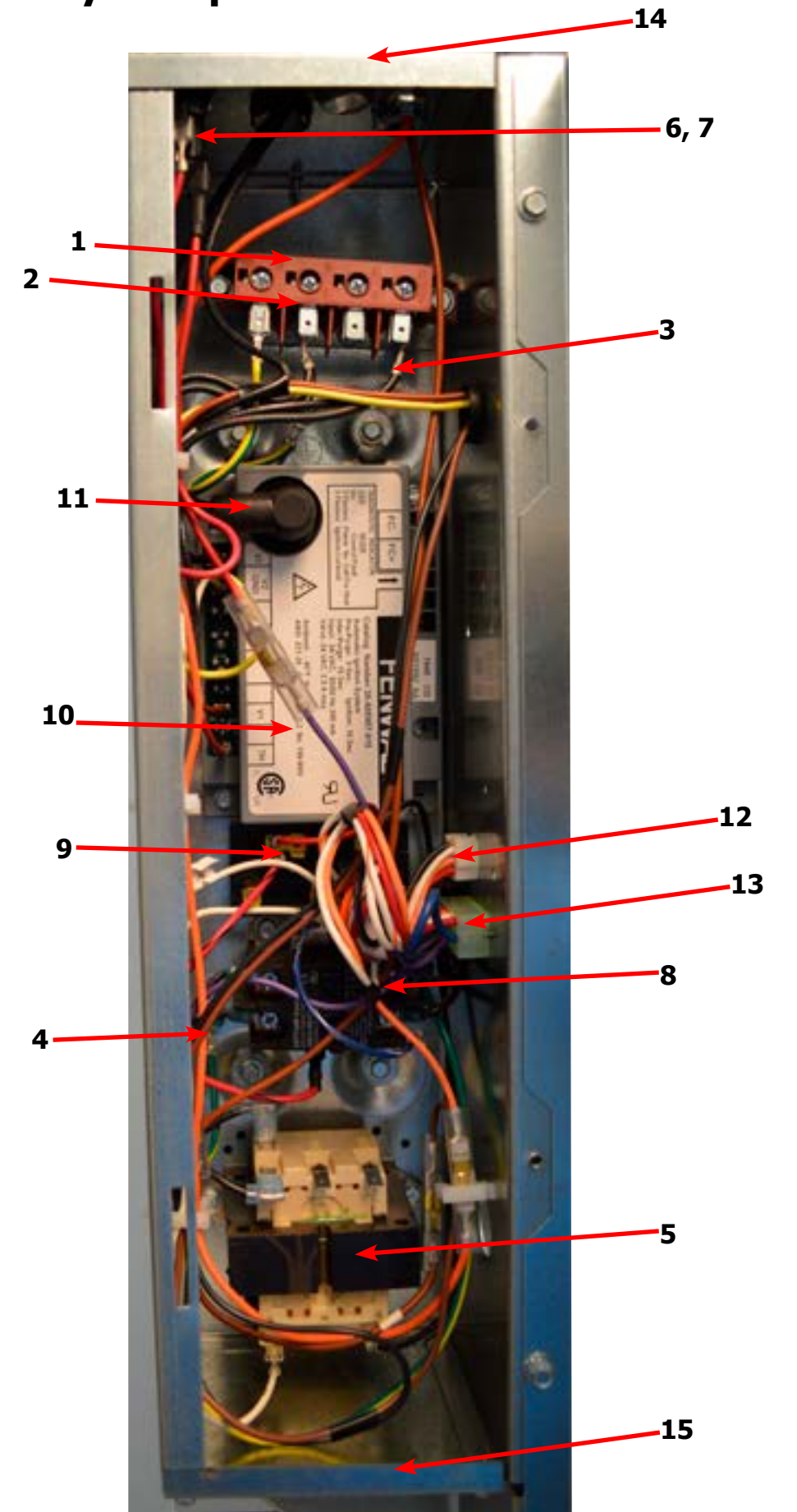

14

6, 7

1

2

3

11

10

9

12

13

8

4

5

15

Control Assembly Group

Key	Description	T-30 SWD	QTY
*	Control, Rear	9857-234-001	1
*	Bracket, Terminal Block Power	9029-202-001	1
1	Strip, Terminal Marker	9558-029-003	1
2	Terminal-Block, Power, 4 Pole	9897-035-001	1
*	Screw, 10AB x 3/8"	9545-008-024	4
3	Harness Assembly-Power Main Fork, Upper	9627-859-007	1
4	Wire Assembly-Ground, GRN/YEL, 7"	8220-137-002	1
*	Lock Washer, Ext tooth #10	8641-582-006	1
*	Screw, 10-32 x 1/2"	9545-008-027	1
5	Transformer, 208/240/60Hz. 24/120VAC	8711-007-002	1
*	Screw, 10AB x 3/8"	9545-008-024	2
6	Fuse Holder Assembly	9200-001-002	1
7	Fuse, 1.5Amp/250V-Fast Acting	8636-018-001	1
8	Relay, Motor, 30Amp 24VAC	5192-299-002	1
*	Screw, Phillips, 8AB x 1/2"	9545-045-012	2
9	Terminal Block, Power	9897-026-001	1
*	Screw, Phillips, 8AB x 1/2"	9545-045-012	2
*	Harness-Assembly, Low Voltage, Upper	9627-867-011	1
10	Ignition Module	9857-182-001	1
*	Screw, 10AB x 3/4"	9545-008-018	2
11	Wire Assembly, High Voltage	9631-403-009	1
*	Door-Control Box	9108-141-001	1
*	Screw, 10AB x 3/8"	9545-008-024	3
12	Harness, Main (Internal Box)	9627-863-003	1
*	Harness Main Extension (External Box)	9627-913-003	1
13	Harness Motor	9627-864-007	1
14	Control Box Panel Upper	9454-943-001	1
15	Control Box Panel Lower	9454-697-001	1
*	Control Box Wrapper	9636-216-001	1
*	Wire Red/Black 8"	8220-062-047	1
*	Wire White #11, 14"	8220-062-038	1
*	Wire-Blue/White 5.5"	8220-062-026	1
*	Wire Black/Red #9 9"	8220-146-001	1

Door Switch Group

Key	Description	T-30 SWD	QTY
1	Door Switches (Rectangle)	9539-487-001	2
2	Bracket-Mounting lint tray switch	9029-303-001	1
3	Conduit-Wire	6068-051-001	1
*	Grommet Wire 1/2 i.d.	9029-089-001	1

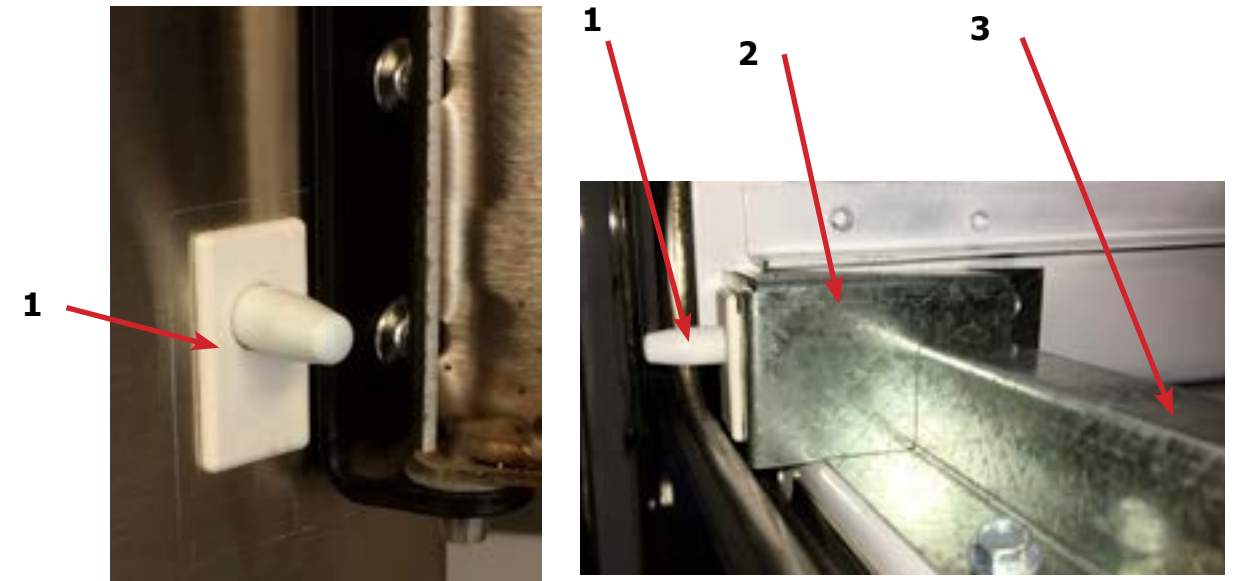

Hinge Plate Cover

Key	Description	T-30 SWD	QTY
1	Cover-Hinge, Black	9074-341-002	1
2	Screw-TRHDCR, 10B x 3/8, Black	9545-008-010	2

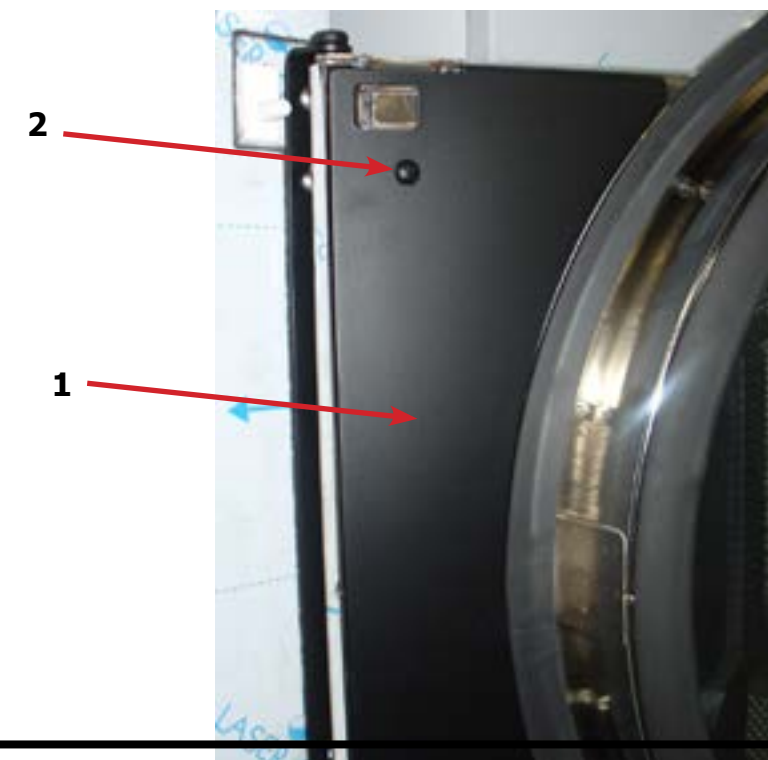

Control Group

Key	Description	T-30 SWD	QTY
	Control Assembly	9857-227-001	1
1	Membrane Switch OPL Black	9801-111-001	1
*	Wire Assembly Green/Yellow	8220-137-002	1
*	Wire Assembly Green	8220-001-478	1
2	Nut-Hex #6-32	8640-411-003	1
3	Nut-Hex #6-32	8640-411-001	3
4	PCB Assyembly-Controller opl	9471-016-001	1
5	Plastic Spacer #6x1/2	9538-157-016	4
6	Plate Assembly opl ptd	9982-391-002	1

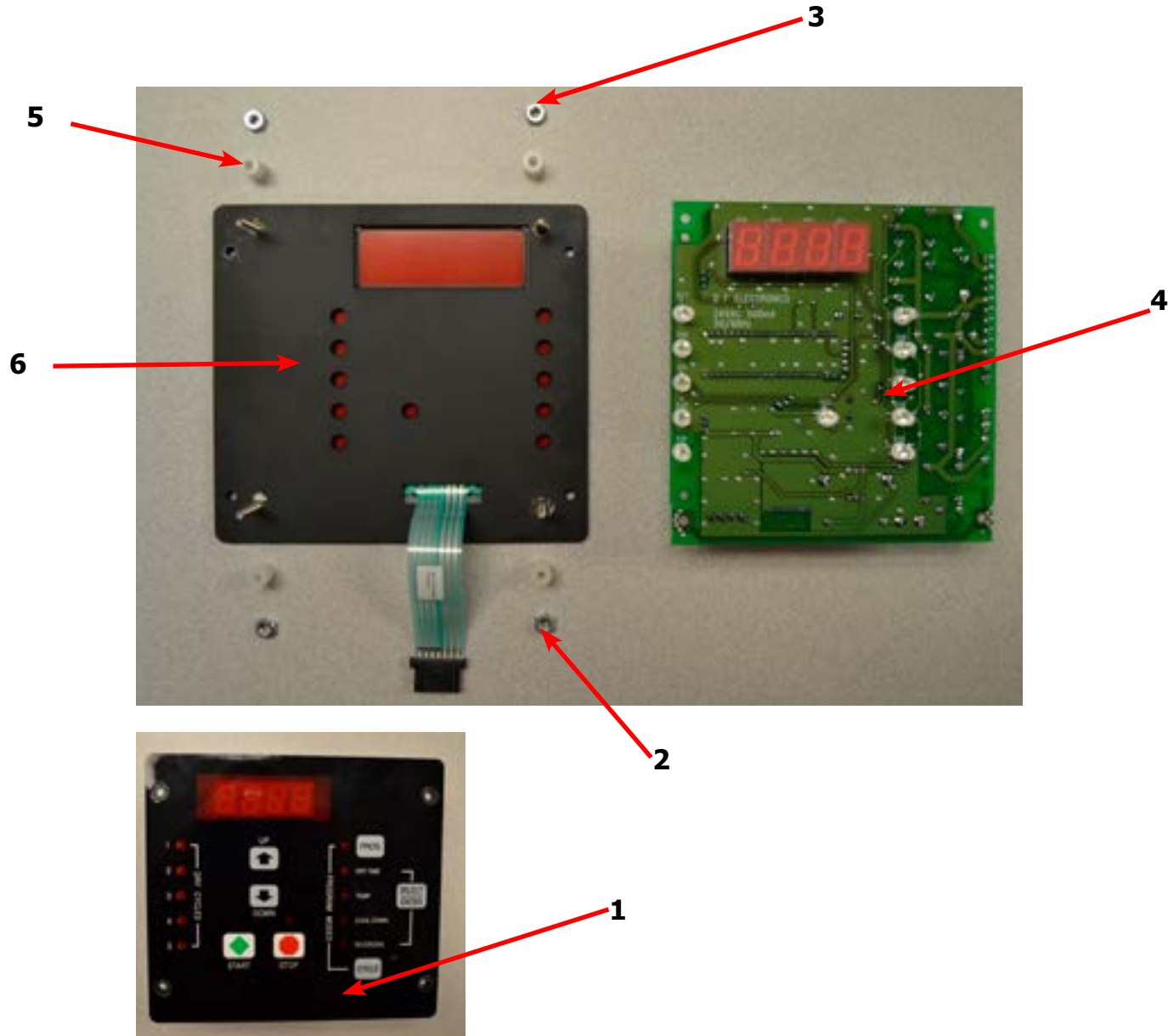

Wiring Schematic Dryer

9506-830-001PR

SCHEMATIC

DNS030N_-15_B_X-_-_-X

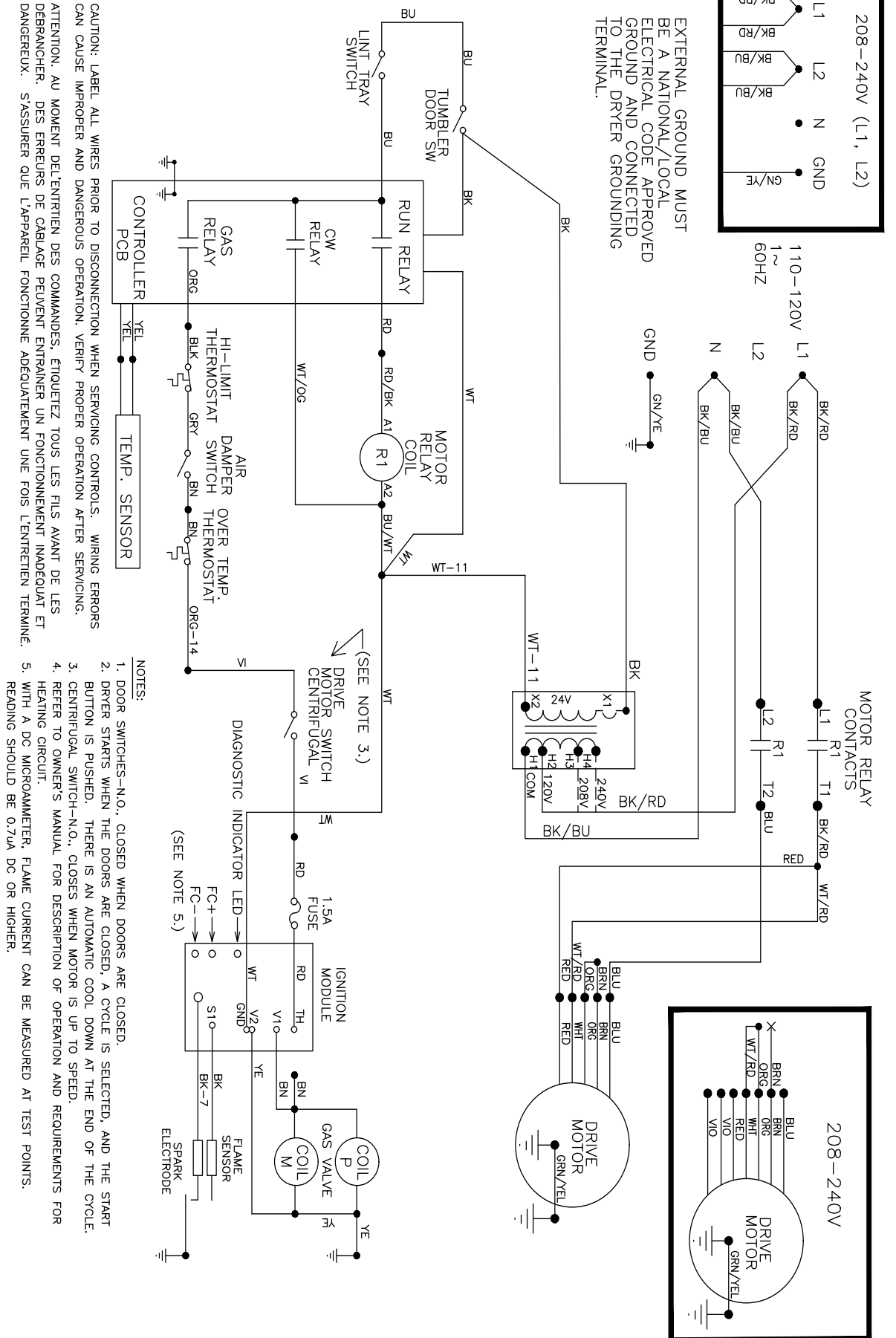

T-30 SWD -39 50 Hz Parts

Key	Description	Part Number	Qty
*	Strip, Terminal Marker -39 Models	9558-029-004	1
1	Transformer	8711-007-002	1
*	Instructions, Transformer Connect	8507-230-003	1
2	Ignition Control -39 Models	9857-182-001	1
*	Harness-Ignition Control,	9627-867-011	1
3	Wire Assembly High Voltage	9631-403-009	1
4	Motor	9376-318-002	1
5	Pulley, Motor Drive	9453-169-009	1
6	Harness Motor Extension	9627-864-007	1
*	Wiring Label Schematic/Diagram -39 models	9506-832-001	1
*	Owner's Manual	8514-287-001	1
*	Lint Drawer Assembly -39 Models	9866-004-013	1

Section: 7
50 Hz Gas Dryer

Rear View Photos

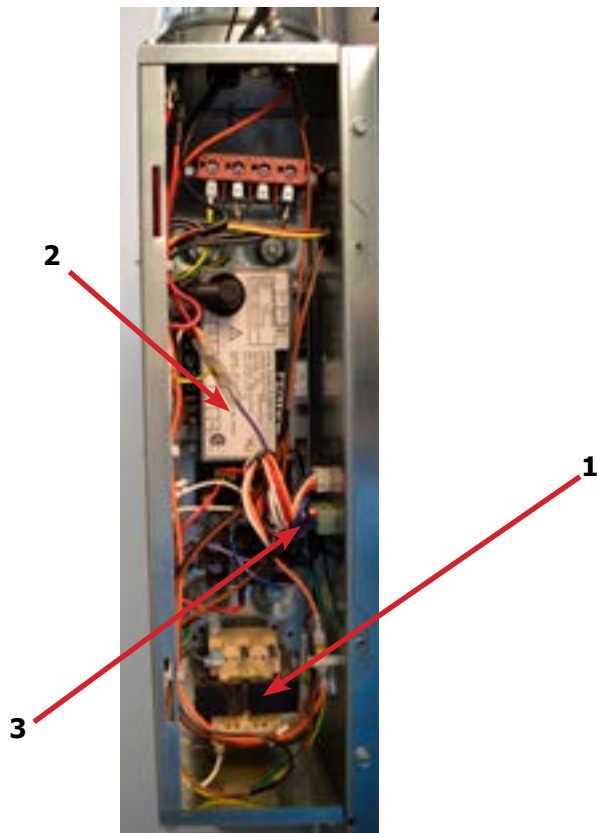
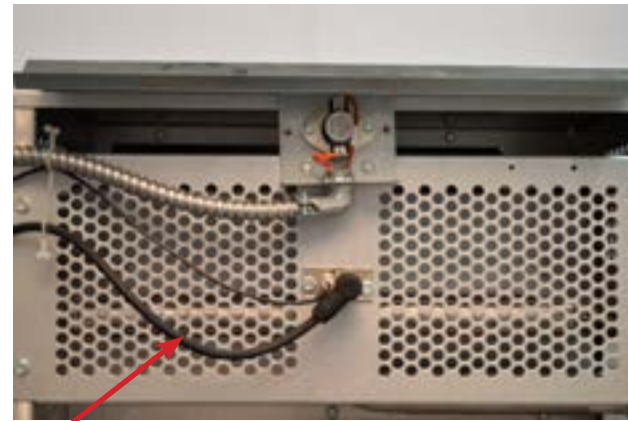
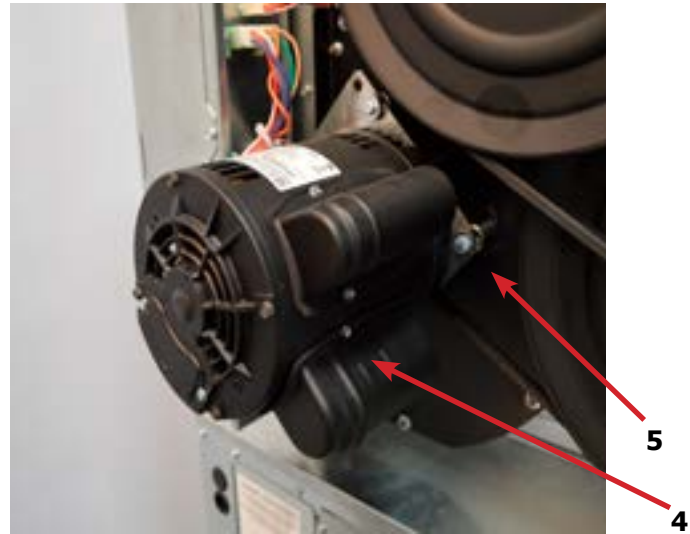

T-30 SWD -39 Gas Control Parts

Key	Description	Part Number	Qty
1	Kit-Honeywell VR86 Valve Flange	9732-162-001	1
*	Orifice, Main Burner #32	9425-069-009	2
2	Gas Control Valve	9857-132-004	1

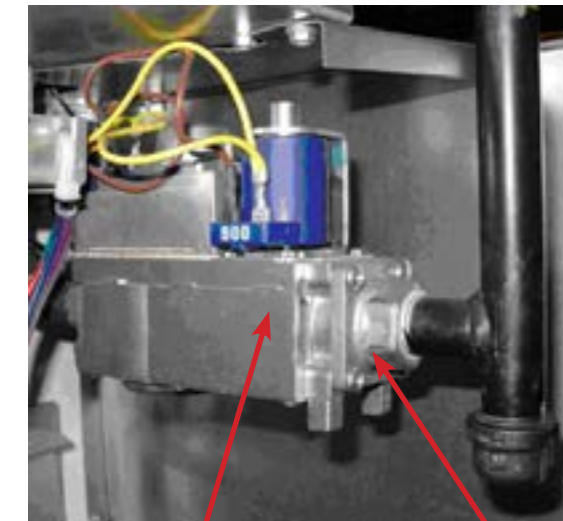

Air Flow Switch Assembly

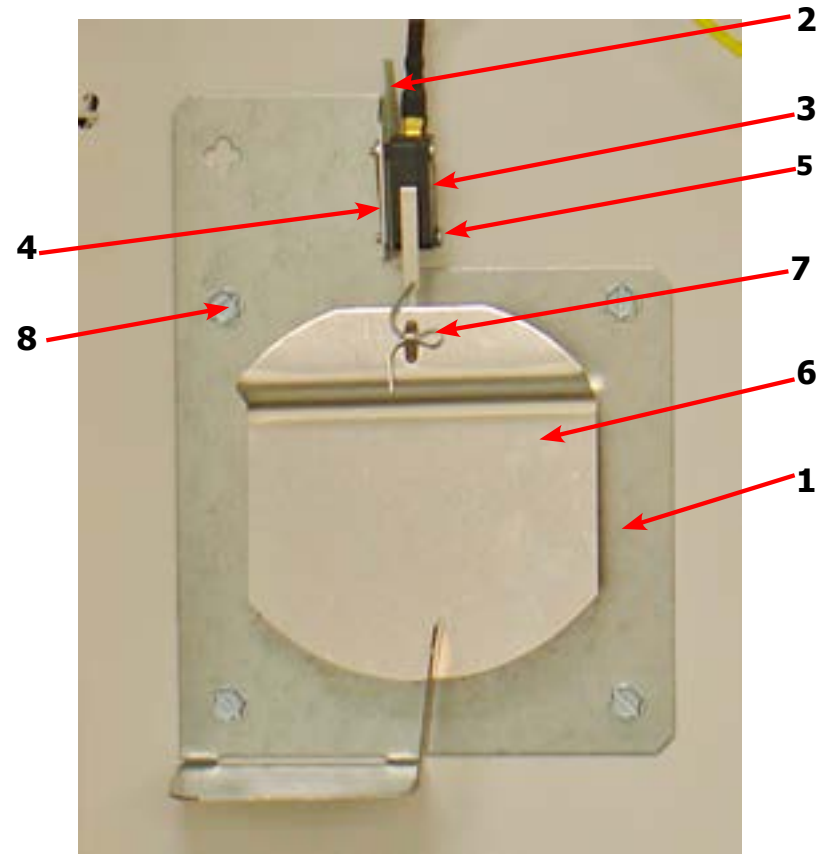

	Description	T-30 SWD-39	QTY
*	Air Flow switch Assy	9801-095-002	1
1	Bracket-Airflow switch	9029-174-001	1
2	Shield-Switch	9550-169-003	1
3	Switch-Micro	9539-461-009	1
4	Nut-Twin, 4-40	8640-401-001	1
5	Screw-.625, 4-40	9545-020-001	1
6	Actuator-Air Flow Switch	9008-007-001	1
7	Pin-Cotter, .09375x.75	9451-169-002	1
8	Screw, 10ABx1/4	9545-008-001	4
*	Harness Assembly, Overtemp/Airflow	9627-861-001	1

Wiring Schematic for Dryer 50hz 230V

