



DEXTER[®]
LAUNDRY

**USE THE BLUE TABS LOCATED ON THE
RIGHT AND LEFT SIDES OF THE FOLLOWING
DOCUMENT TO ADVANCE TO EACH SECTION.**

Kits, Assemblies, & Common Parts

Coin Acceptor Components	Part Number
Mechanical Coin Acceptor	9021-001-010
Coin Drop Screws	9545-053-002
Retainer, Coin Acceptor	9486-149-001
Loading Door Components	Part Number
Door Handle	9244-082-001
Door Close Switch	9539-487-001
Electrical Components	Part Number
Relay, Motor Run (120VAC)	5192-295-016
Transformer, Ignition/Control (120VAC)	8711-011-001
Controls 120VAC (Blue)	9857-147-010
Controls 120VAC (Black)	9857-147-014
Heating Circuit Components	Part Number
Ignition Control Module	9857-116-003
Ignition Electrode Assembly	9875-002-003
Thermostat, Hi-Limit	9576-203-002
Thermostat, Overtemp	9576-207-008
Fuseholder	9200-001-002
Fuse 1.5 amp	8636-018-001
Airflow Switch	9539-461-009
Cabinet Components	Part Number
Cleanout Duct Assembly 8"	9973-034-001

Section 6: Parts Data

DDAD50KC -65

Parts Data

Cabinet Group

Key	Part Number	Description	Quantity
*	9960-285-003	Door Assy., Loading Complete-Alm.....	2
*	9960-285-002	Door Assy., Loading Complete-Wht.....	2
*	9960-285-001	Door Assy., Loading Complete-SS.....	2
1	9960-284-002	Door Assy., Loading-SS(ring only).....	2
2	9982-353-003	Plate Assy., Hinge (Alm) No Pin.....	2
2	9982-353-002	Plate Assy., Hinge (Wht) No Pin.....	2
2	9982-353-001	Plate Assy., Hinge (SS) No Pin.....	2
*	9545-012-015	Screw, Hinge to Door.....	8
*	8640-413-002	Nut, Hinge to Door.....	8
3	9212-002-004	Glass, Door.....	2
4	9206-164-010	Gasket, Glass.....	2
*	9548-117-000	Support, Door Glass.....	2
5	9206-420-004	Gasket, Outer Rim.....	2
6	9244-082-001	Handle, Loading Door.....	2
*	9545-018-017	Screw, Handle 1/4-20 x 3/8.....	2
*	9531-033-001	Stud, Door Catch.....	2
*	8640-413-001	Nut, Hex.....	2
*	8640-413-003	Nut, Acorn.....	2
*	9086-015-002	Catch, Loading Door.....	2
*	8638-190-009	Pop Rivet for mtg. catch.....	4
*	8641-582-006	Lockwasher.....	4
*	8640-399-001	Spring Nut.....	6
7	9989-517-008	Panel Assy., Front- Lower (Alm).....	1
7	9989-517-007	Panel Assy., Front- Lower (Wht).....	1
7	9989-517-005	Panel Assy., Front- Lower (SS).....	1
8	9989-517-004	Panel Assy., Front- Upper (Alm).....	1
8	9989-517-003	Panel Assy., Front- Upper (Wht).....	1
8	9989-517-001	Panel Assy., Front- Upper (SS).....	1
*	9277-054-001	Insulation Front Panel, half moon (top).....	2
*	9277-054-002	Insulation Front Panel, half moon (bottom).....	2
*	9545-008-014	Screw, FLHDCR, 10B x 1.....	14
*	8641-585-001	Lockwasher.....	6
*	8640-399-001	Nut, Spring.....	12
10	9544-069-003	Strap, Hinge (Alm).....	2
10	9544-069-002	Strap, Hinge (Wht).....	2
10	9544-069-004	Strap, Hinge (SS/Gray).....	2
*	9545-012-028	Screw, Hinge to Panel.....	8
11	9545-052-001	Screw, Door to Hinge Strap (Special Black Type).....	2
*	8641-436-003	Washer, Fiber.....	2
12	9021-001-010	Acceptor, Coin.....	1
*	9486-136-001	Retainer, Coin Acceptor.....	1
13	9545-053-002	Screw.....	4
*	9732-126-001	Switch (for coin acceptor with extra actuator).....	1

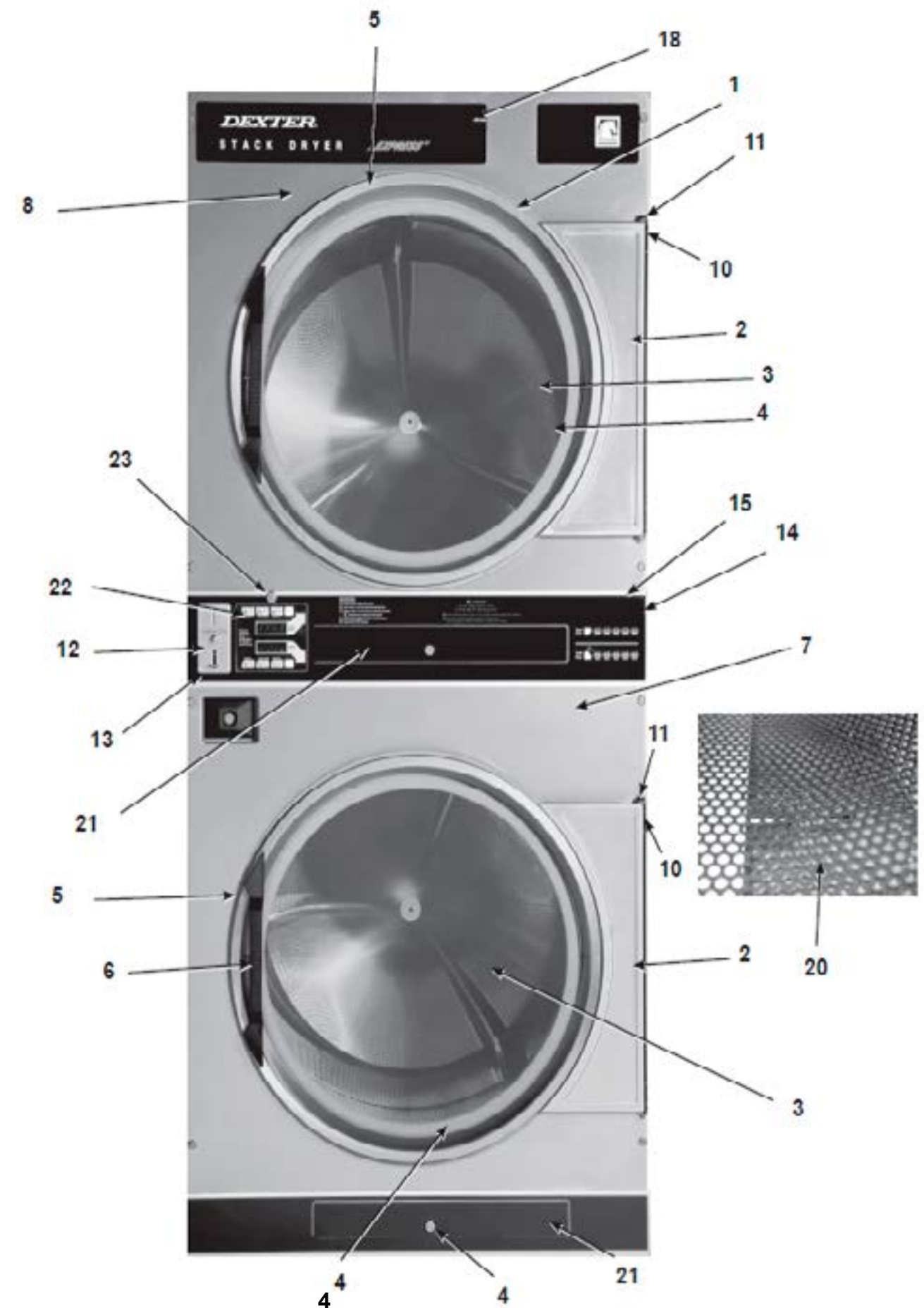

Cabinet Group Continued

Key	Part Number	Description	Quantity
14	9994-032-001	Escutcheon, Upper.....	1
15	9435-022-001	Trim, Overlay-Upper.....	1
16	9994-033-001	Escutcheon, Lower.....	1
17	9435-023-001	Trim, Overlay-Lower.....	1
*	9545-020-009	Screw.....	10
18	9412-154-001	Nameplate Stack Dryer Express.....	1
21	9866-005-001	Lint Drawer Assembly.....	2
21	9435-024-001	Overlay Trim, Lint Drwr.....	1
*	9532-074-003	Felt Seal (back of lint screen assembly).....	2
*	9805-033-002	Lint Screen Assembly ONLY (no front).....	2
*	9555-057-008	Replaceable Lint Screen Only.....	2
24	8650-012-004	Lock and Key, Lint Drawer.....	2
*	6292-006-007	Key 6324 only.....	2
*	9095-043-001	Cam, Lock.....	2
*	9545-008-001	Lint Screen Strap Hold Down Screws 10Bx 1/4.....	32
22	9857-147-001	Controls Assy, Electronic Mounted With Membrane Switch.....	1
22	9801-059-005	Membrane Switch Assy.....	1
*	9627-869-001	Harness, Electronic Control.....	1
*	9627-895-001	Harness Coin Sw.....	1
23	8650-012-003	Lock and Key, Control.....	1
*	9095-041-001	Cam, Lock.....	1
*	9627-870-001	Harness, Heat Sensor.....	1
*	9277-041-017	Insulation Cabinet Cover.....	1
20	9501-004-003	Sensor Temp Control.....	2
*	9545-045-005	Screw, Round Head (Mounts sensor; phillips head).....	2
*	9209-037-002	Gromm.et, 3/16 ID.....	2
*	8544-006-001	Leg, Leveling 1/2".....	4
*	9074-320-001	Cover, Cabinet (Top).....	1
*	9732-253-001	DDAD Kit for Dryers without Neutral and using 208-240 volt.....	1
*	9732-102-013	LP Kit for DDAD Dryers.....	1
*	9732-243-001	Stack Dryer Trunion Puller.....	1
*	9555-057-010	Replaceable Lint Screen Fine Mesh Only.....	1
*	9277-054-001	Insulation-Front Panel-Top Half.....	2
*	9277-054-002	Insulation-Front Panel-Lower Half.....	2
*	9029-169-001	Bracket for Heat Sensor Mounting (Under Basket).....	2
*	8640-276-002	Wire Nut Connector Grey.....	4
*	9527-007-002	Standoff Wire Saddle.....	8
*	9544-041-002	Strap - Bead Tie.....	1

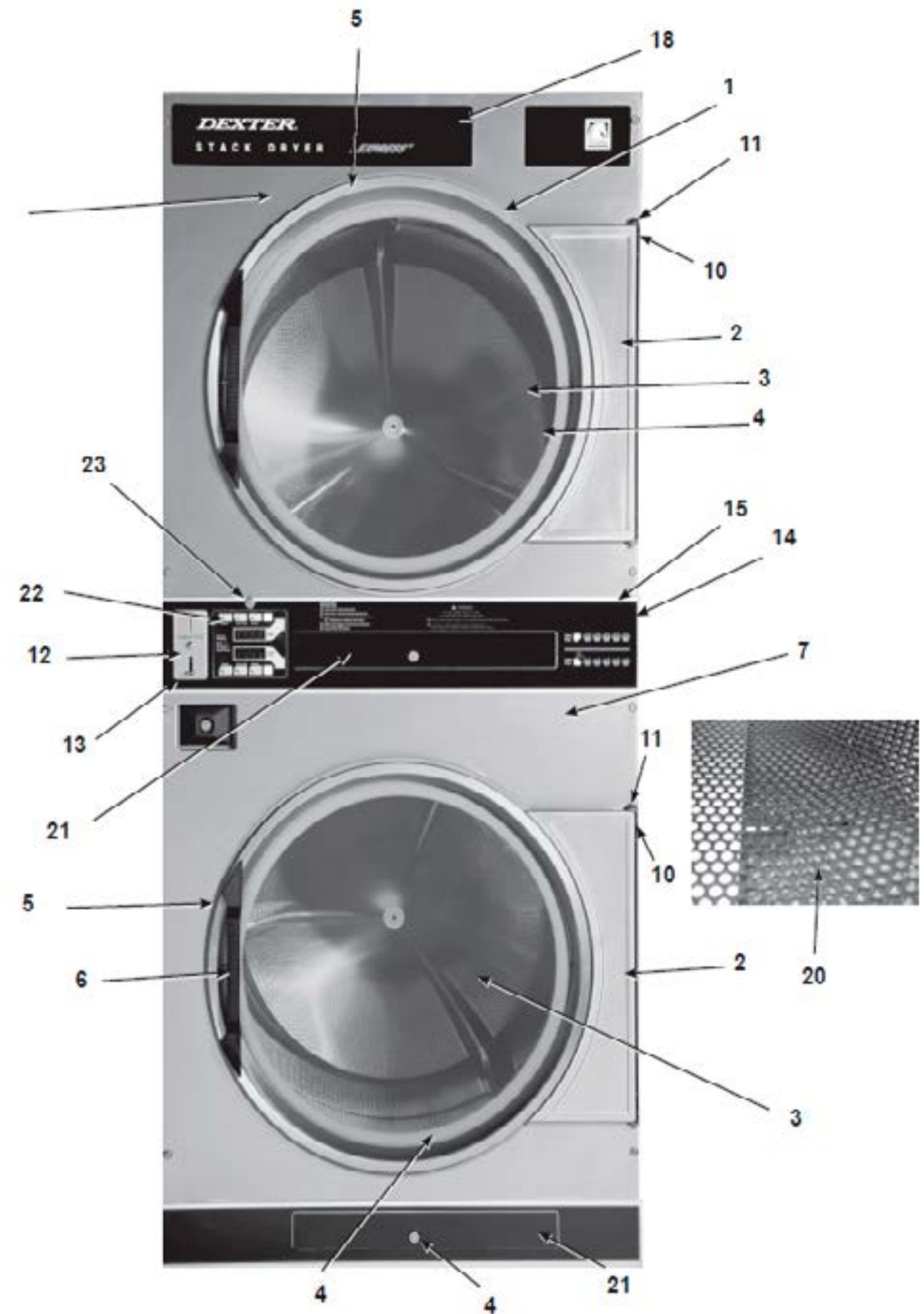

Burner Housing Group

Key	Part Number	Description	Quantity
*	9803-203-001	Housing Assembly, Burner.....	2
1a	9452-730-001	Service Burner Plate Front.....	2
1	9452-729-001	Service Plate baffle Recirculation Chamber Clean Out.....	2
*	9545-008-006	Screws	8
2	9545-008-001	Screw	16
18	9003-220-001	Angle, Burner Support	2
*	9545-008-006	Screw	4
17	9048-020-002	Burner, Main.....	4
*	9545-008-006	Screw 10AB x 3/8"	4
*	9454-806-001	Panel, Back Burner Housing.....	2
4	9545-008-001	Screw 10B x 1/4"	8
5	9875-002-003	Electrode Assy, Ignition.....	2
19	9545-045-001	Screw, Electrode Mtg 8B x 1/4"	4
7	9379-186-001	Valve, Gas Shut Off.....	1
8	9857-134-001	Control Assy, Gas	2
9	9381-009-006	Manifold, Assy.....	2
*	9425-069-010	Orifice, Burner-Natural #27	4
*	9425-069-024	Orifice, Burner-LP #44	4
10	9029-175-001	Bracket, Manifold	2
14	9039-915-001	Bracket, Gas Control.....	2
22	8615-104-038	Pipe Plug in end of Burner Manifold	2
11	9452-749-001	Plate Assy, Hi-Limit Stat Ignitor.....	2
*	9545-008-006	Screw	4
12	9576-203-002	Thermostat, Hi-Limit	2
*	9538-142-001	Spacer, Hi-Limit.....	4
*	9545-045-007	Screw 8B x 3/4"	4
13	9074-234-001	Cover, Hi-Limit Stat Ignitor	2
*	9545-008-006	Screw	6
*	9576-207-008	Thermostat, Safety Shutoff	2
*	9545-008-006	Screw	4
15	9825-058-001	Cover, Safety Stat	2
*	9545-008-006	Screw	4
16	9857-116-003	Control, Ignition Fenwall (3 trybox)	2
*	9550-189-001	Shield, Burner Inlet.....	1
*	9732-102-001	Kit, LP Conversion DDAD Kit.....	2
*	9838-018-002 ^	Welded One Piece Gas Pipe Assembly (Used After 9/07)	
*	9381-012-001 ^	Manifold Assembly 2 Port One Piece Used After 9/07	

^ Models built before 9/07

Burner Housing Group Photos

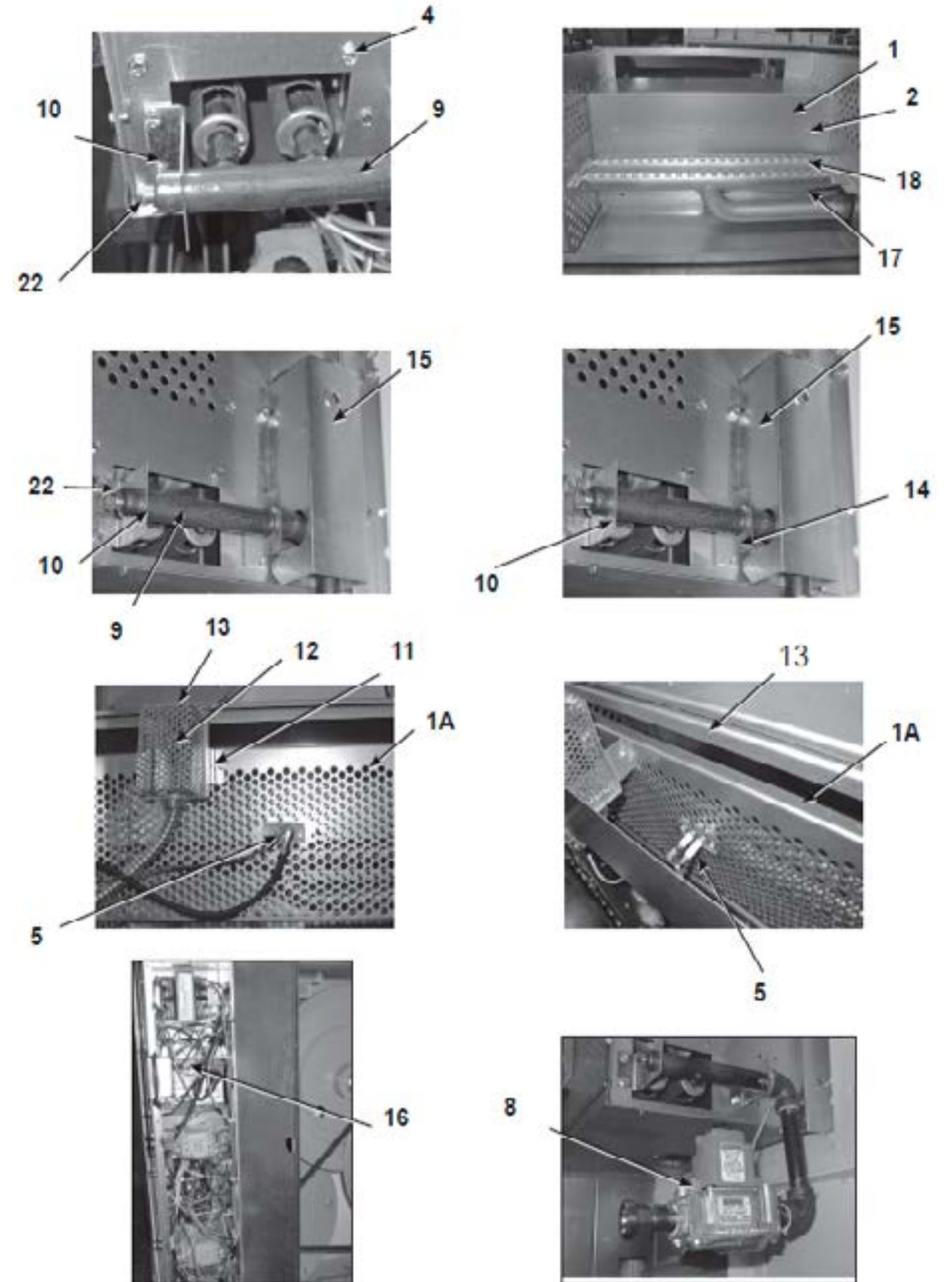

Rear View

Key	Part Number	Description	Quantity
*	9627-875-001	Wire Harness Overtemperature Switch Upper	1
*	9801-095-001	Switch Assy, Air Flow	2
1	9539-461-009	Switch, Air Flow	2
2	9029-174-001	Bracket, Switch- Air Flow	2
3	9008-007-001	Actuator, Switch	2
4	9451-169-002	Pin, Cotter	2
5	9545-020-001	Screw 4-40 x 5/8"	4
7	9376-313-001	Motor, Drive	2
8	9452-754-002	Plate, Impeller Mtg	2
9	9537-204-001	Shaft Impeller	2
10	9803-204-001	Housing Assembly w/ Bearings for Impeller	2
10	9453-157-001	Pulley - Impeller Drive	1
11	9991-053-001	Support Assy, Intermed. Pulley	2
12	9545-029-010	Bolt, Rd Hd 3/8-16 x 1 1/4	6
12	8640-415-004	Nut Flange Wizlock 3/8" - 16	6
12	8641-581-035	Washer, Flat	6
13	9545-029-003	Bolt, 3/8-16 x 1 1/2	2
14	9861-022-001	Arm Assy-Tension, Complete	2
*	9487-200-003	Ring-Retaining	6
16	9908-046-003	Pulley Assy, Intermediate with bronze flange bearing	2
17	9908-040-003	Pulley Driven Tumbler	2
19	9040-076-004	Belt, Drive Impeller and Intermediate Pulley	2
20	9040-073-010	Belt, Driven Intermediate to Tumbler	2
21	9534-151-000	Spring, Tension	2
22	9099-012-005	Chain, Tension	2
23	9248-022-002	Hook, Tension	2
*	9451-146-001	Pin, Damper Hinge	2
*	9825-322-001	Cover Duct Upper	1
25	9973-030-001	Heat Recirculation Assembly Duct	2
26	9919-018-001	Impeller Assembly Complete w/ Bearings, Shaft, Plate	2
27	9453-157-001	Motor Pulley - Driver	1
28	9545-028-013	Set Screws	2
29	9241-191-002	Bearing Housing Only Impeller	2
30	9278-038-004	Impeller	2
*	9036-159-010	Ball Bearing for Above Impeller Shaft	4
*	9487-200-007	Ring-Retaining External for Impeller Bearing Housing	4
*	9545-018-009	Screw, 1/4-20 x 1 Impeller Bearing Housing	4
34	8641-581-026	Washer, Flat 1/2" for Tumbler Pulley	2
35	9545-017-009	Bolt, 1/2"-13 x 1 1/4	2
36	8641-582-016	Washer, Star 1/2" for Tumbler Pulley	2
*	8640-401-001	Nut, Special Twin #4-40	2
*	9550-169-003	Shield, Switch	2
*	9545-008-001	Screw 10 Bx 1/4"	6
*	9545-014-004	Bolt, 5/16-18 x 5/8"	8
*	8640-400-003	Nut, 5/16-18	8
*	9036-145-002	Bearing - Bronze Flange	4
*	9538-164-001	Spacer, Shaft	2
*	9487-234-005	Ring Tolerance	2
*	9125-006-001	Damper Inside Duct Exhaust	2
*	8520-141-000	Nut, Spring	4
*	9545-008-026	Screw #10B x 1/2"	14
*	9074-323-001	Cover Duct Lower	1
*	9545-008-024	Screw 10ABx 3/8"	58
*	9029-173-001	Bracket for Wire Harness Under Burner Housing	2

Rear View Photos

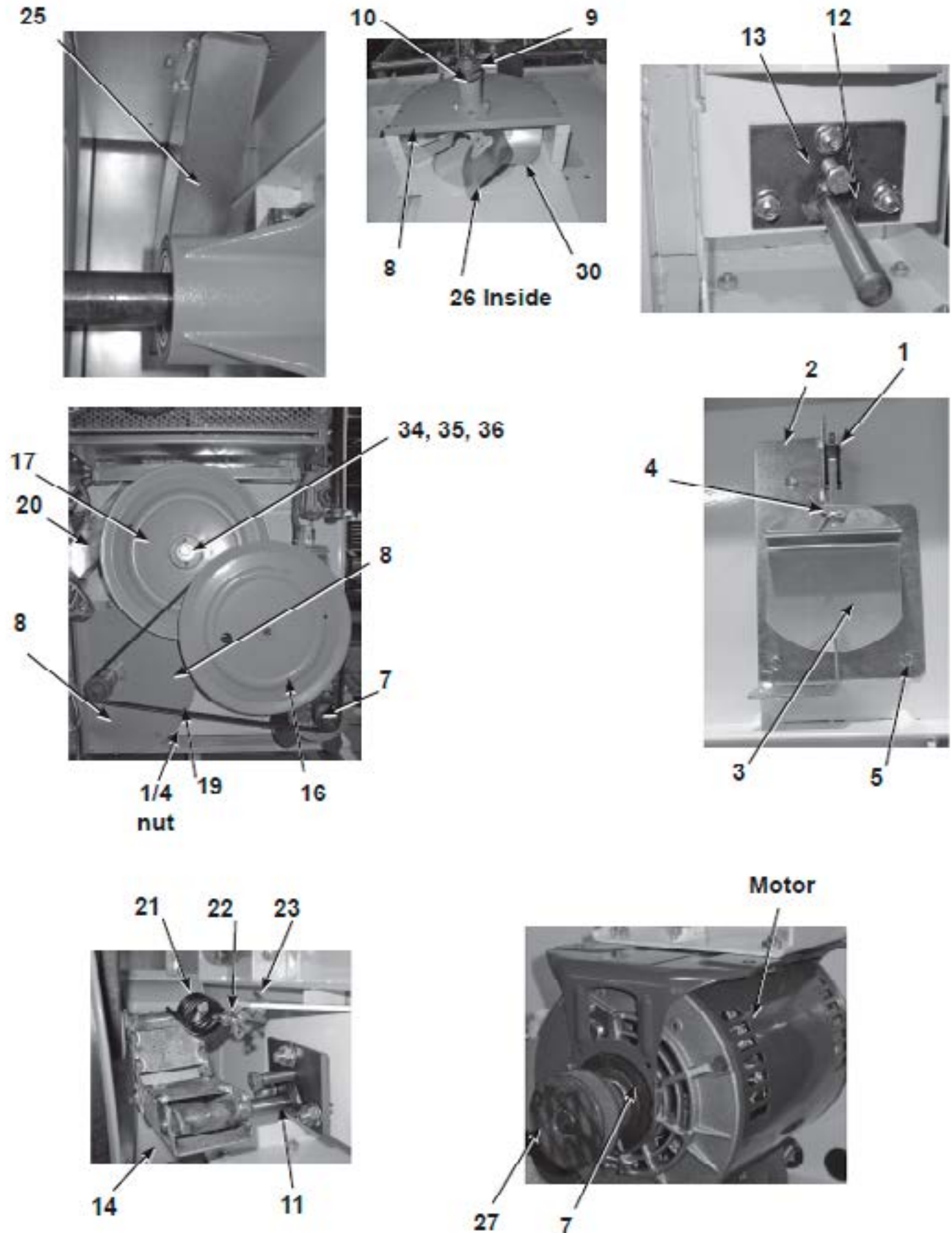

Control Assembly Group

Key	Part Number	Description	Quantity
*	9857-173-001	Control Assmby Complete (all below included)	1
*	9074-324-001	Control Box Cover	1
*	8220-001-478	Wire Assembly Green 7"	1
*	8639-621-007	Screw #10-32 x 12 Green	1
*	8641-582-006	Lockwasher Ext Tooth #10	1
3	9897-026-002	Terminal Block Main Power Middle	1
4	9897-026-001	Terminal Block	2
*	9545-045-012	Screw #8 ABx 1/2 for terminal block	4
5	8711-011-001	Transformer Ignition	2
*	9545-008-024	Screws 10AB x 3/8"	4
6	9982-355-001	Plate Assembly MTG Ignition Control	2
*	9545-008-001	Screws 10B x 1/4" MTG Above Plate and Others	13
7	9857-116-003	Ignition Control	2
*	8640-411-003	#6-32 Nuts	4
8	9631-403-011	Wire Assembly High Voltage Upper	2
9	9627-873-001	Wire Harness Ignition Control Upper	1
10	9627-873-002	Wire Harness Ignition Control Lower	1
*	9053-067-002	Bushing Wire 7/8"	4
13	9200-001-002	Fuseholder Assembly	2
14	8636-018-001	Fuse 1.5 Amp	2
15	5192-295-016	Relay Power	2
16	9897-036-002	Terminal Block Assembly Main Power Inlet	1
*	9545-045-012	Screw #8 AB x 1/2"	3
*	8220-062-036	Wire Assembly Red/Black 14"	1
*	8220-062-037	Wire Assembly Red/White 14"	1
*	8220-062-038	Wire Assembly White 14"	2
*	9627-868-001	Wire Harness - Power Main Input	1
21	9627-874-001	Wire Harness Motor Extension	2
*	9527-007-001	Stand Off - Wire Saddle / Arrowhead	15
*	9545-031-005	Screw 6 B x 3/8"	4
22	9558-031-001	Strip Terminal Marker (Behind Input Power) to above #3	1
*	9627-863-001	Wire Harness Main Extension Access Under Burner Housing	1
23	9631-403-013	Wire Ass'y - High Voltage Lower	1
24	9029-048-001	Bracket - Fuseholder	2
25	9627-859-001	Wire Harness - Main Power	1

Control Assembly Group

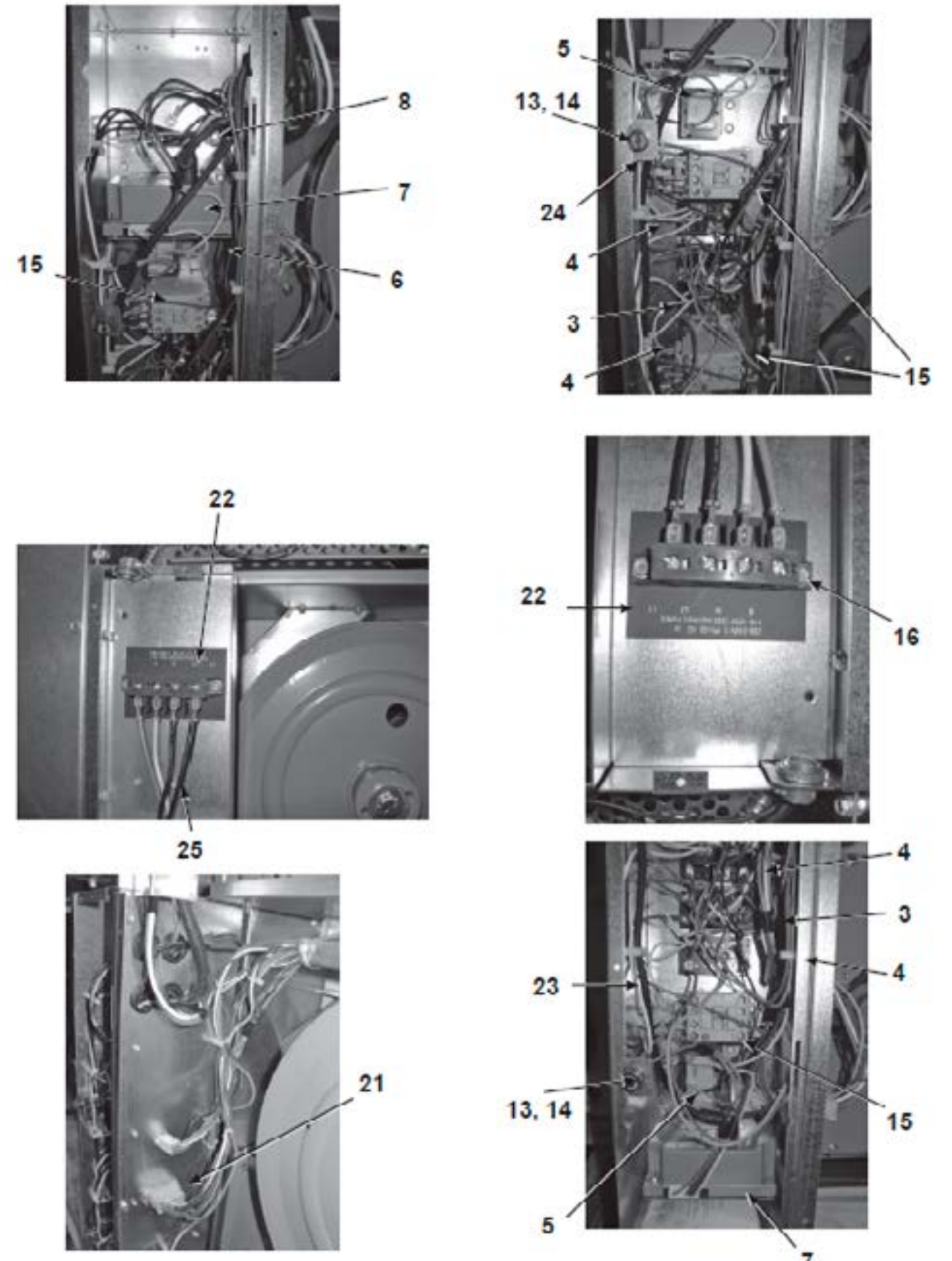

Coin Handling Group

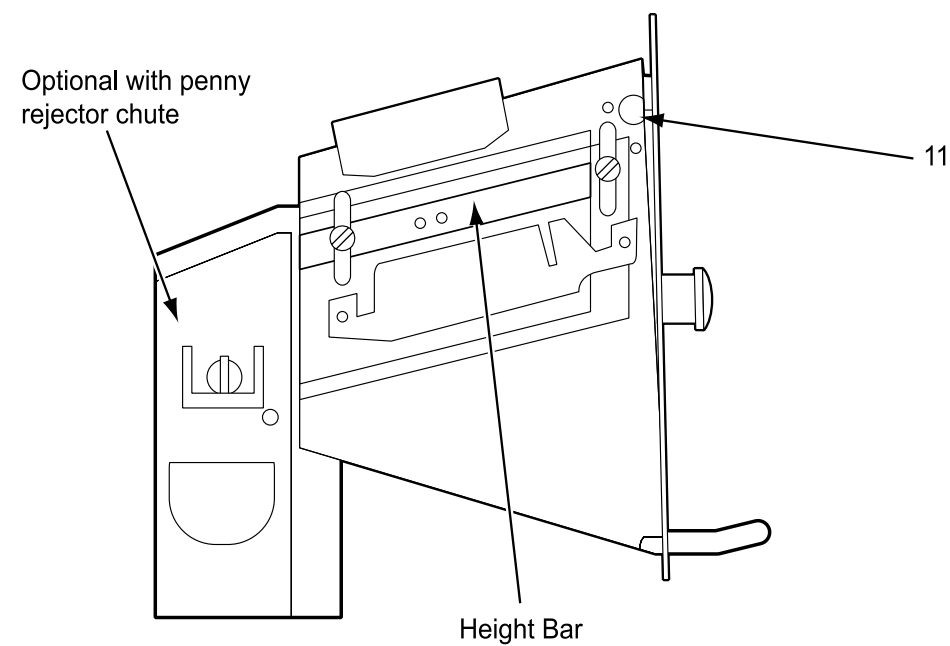
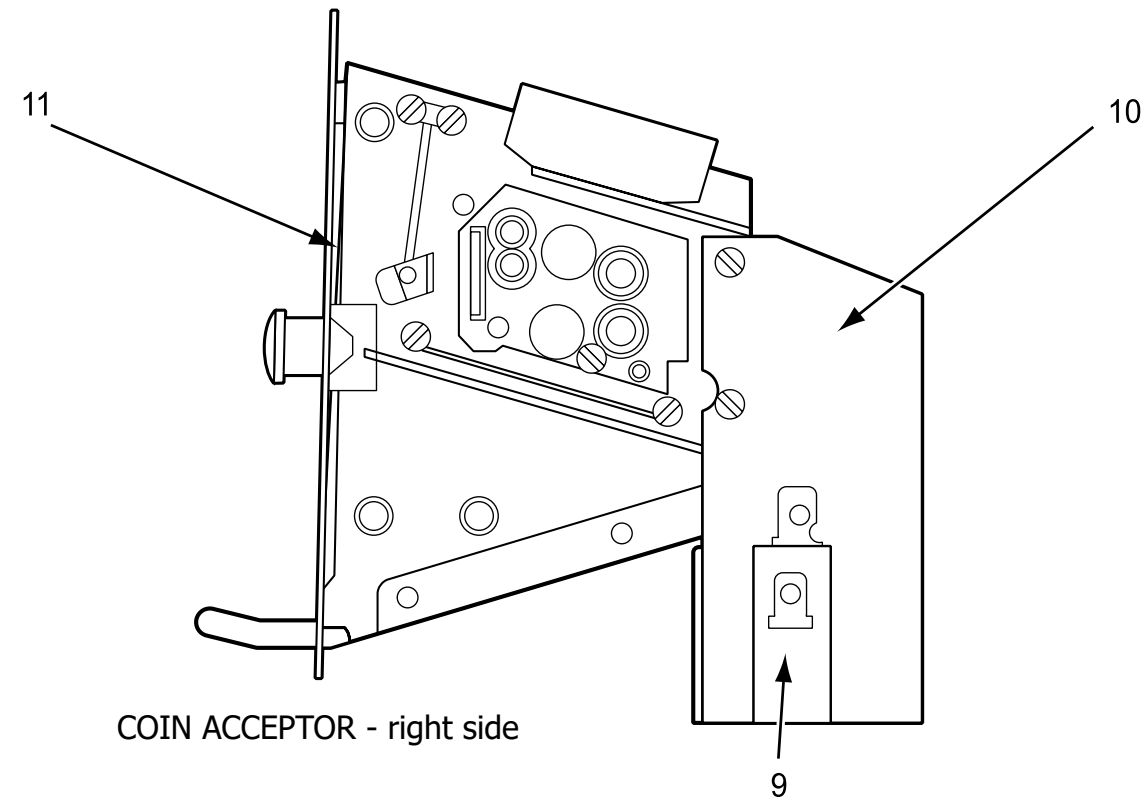

Coin Handling Group

Key	Part Number	Description	Quantity
2	9732-122-001	Kit, Coin Box and Hardware (includes 1-6).....	1
*	9942-035-002	Vault, Assembly Gray (SS front panel)	1
*	9942-035-004	Vault, Assembly Almond	1
*	9942-035-003	Vault, Assembly White	1
1	9807-077-007	Box Assembly, Coin	1
*	9982-338-001	Vault Plate Assembly Coin Vault Mounting.....	4
*	8640-413-004	Nut, Vault Mounting.....	4

NOTE: COIN BOX AND HARDWARE KIT AND COIN BOX LOCK NOT INCLUDED WITH MACHINE.

3	9349-033-001	Latch, Coin Box	1
4	8641-569-002	Washer, Wave	1
5	8641-583-001	Washer, Keeper	1
6	8641-581-008	Washer, Spacer- Thick	2
6	8641-581-010	Washer, Spacer- Thin	4
7	8650-012-002	Lock, Coin Box (w/key not included with 9732-122-001).....	1
8	9021-001-010	Acceptor, Coin.....	1
*	9545-053-002	Screw, Acceptor Mtg.....	4
9	9732-126-001	Switch, Coin	1
10	9119-025-002	Acceptor Chute Ass'y w/o penny ejector	1
*	9119-025-001	OPTIONAL Acceptor Chute W/ penny rejector	*

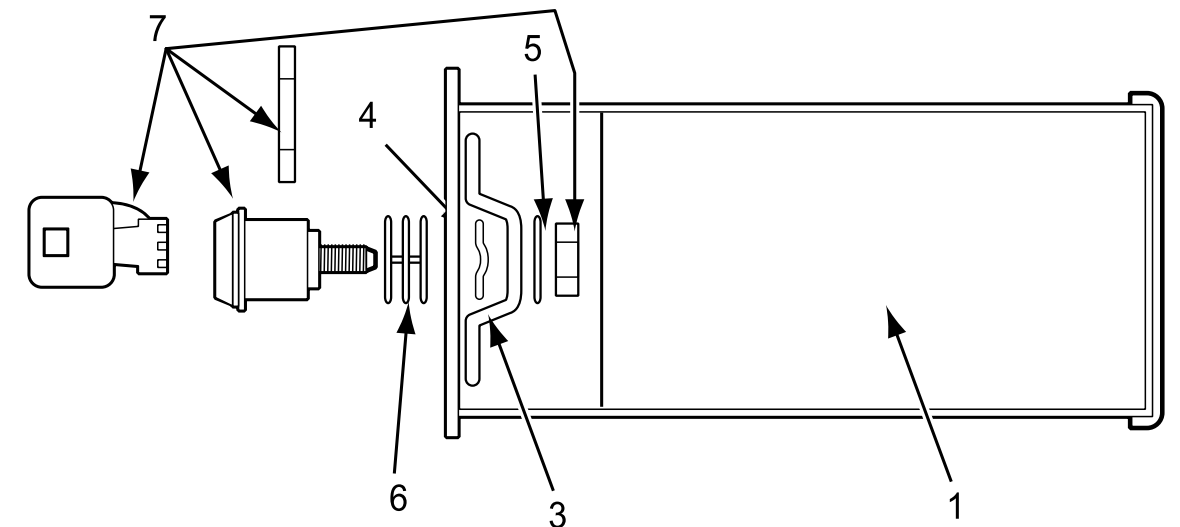

Preventative Maintenance

Daily

- Step 1:** Clean the lint screen free of lint and other debris. Use a soft brush and Hot water if necessary.
- Step 2:** Check the lint screen for tears. Replace if necessary.
- Step 3:** Clean lint from the lint screen compartment.
- Step 4:** Inspect felt seal on lint screen assembly, replace if needed.

Monthly

- Step 1:** Remove lint accumulation from the end bells of the motor.
- Step 2:** Remove lint accumulation from front control area.
- Step 3:** Remove lint and dirt accumulation from the top of the dryer and all areas above, below, and around the burners and burner housing. Failure to keep this portion of the dryer clean can lead to a build-up of lint creating a fire hazard.
- Step 4:** Remove and clean coin acceptors. (Vended Models Only)

Quarterly

- Step 1:** Check the belts for looseness, wear, or fraying.
- Step 2:** Inspect the gasket of the door glass for excessive wear.
- Step 3:** Check tightness of all fasteners holding parts to support channel.
- Step 4:** Check tightness of all set screws.
- Step 5:** Remove the air flow switch assembly and check the tumbler thru-bolts for tightness.
- Step 6:** Apply a few drops of oil to pivot pins and the tension arms where in contact with each other.

Semi-Annually

- Step 1:** Remove and clean the main burners.
- Step 2:** Remove all orifices and examine for dirt and hole obstruction.
- Step 3:** Remove all lint accumulation. Remove the front panel and the lint screen housing and remove lint accumulation.

Annually

- Step 1:** Check the intermediate pulley bearings for wear.
- Step 2:** Check and remove any lint accumulation from the exhaust system including recirculation chambers if applicable.
- Step 3:** Grease the bearings and the shaft of the intermediate pulley. Use an Alemite grease gun and Molykote BR2-S grease. (Where applicable)

Section 8: Voltage Conversion

Instructions - Convert a Dual Voltage Stack Dryer from 120V to 208-240V with Neutral Wire Only

1. Remove incoming power from the dryer. Use a known working voltmeter to check power.
2. Remove the cover of the control box assembly from the dryer using a 5/16" wrench.
3. Move the black/blue wire from the N position of the main power terminal block to the L2 position of the main power terminal block in the control box assembly.
4. Move the white wire of the upper motor harness to an upper inner left terminal in the middle terminal block in the control box assembly. See Figure 1 below.
5. Move the orange wire of the upper motor harness to an upper inner left terminal in the middle terminal block control box assembly. See Figure 1 below.
6. Move the white wire of the lower motor harness to a lower inner left terminal in the middle terminal block in the control box assembly. See Figure 1 below.
7. Move the orange wire of the lower motor harness to a lower inner left terminal in the middle terminal block control box assembly. See Figure 1 below.
8. Reconnect power to the dryer and test to ensure proper operation; one line voltage to L1, one line voltage to L2, the neutral to N, and the earth ground to E.
9. Reinstall the cover of the control box assembly from the dryer using a 5/16" wrench.

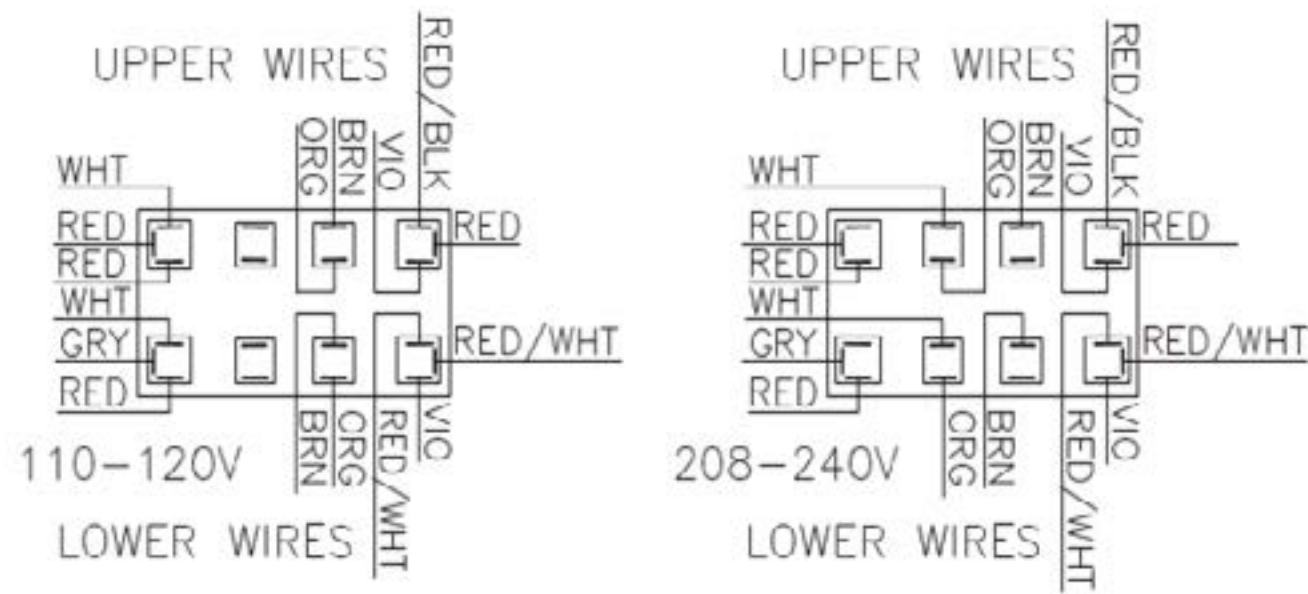
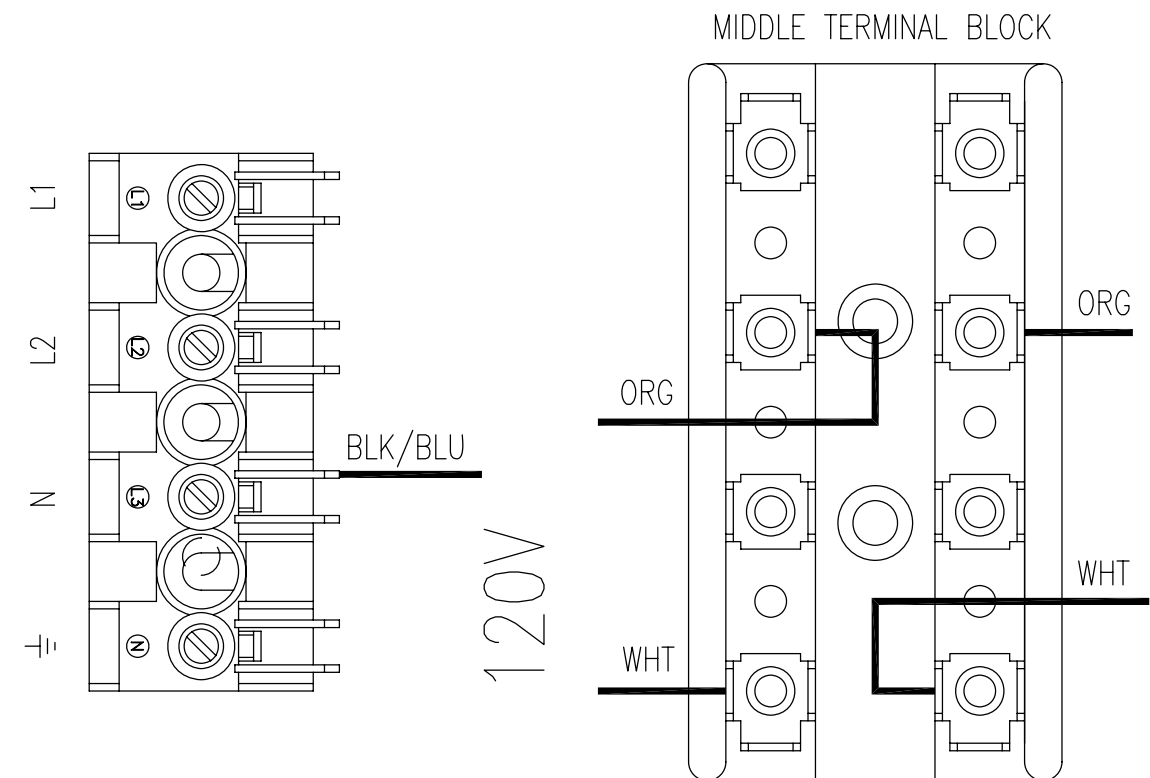
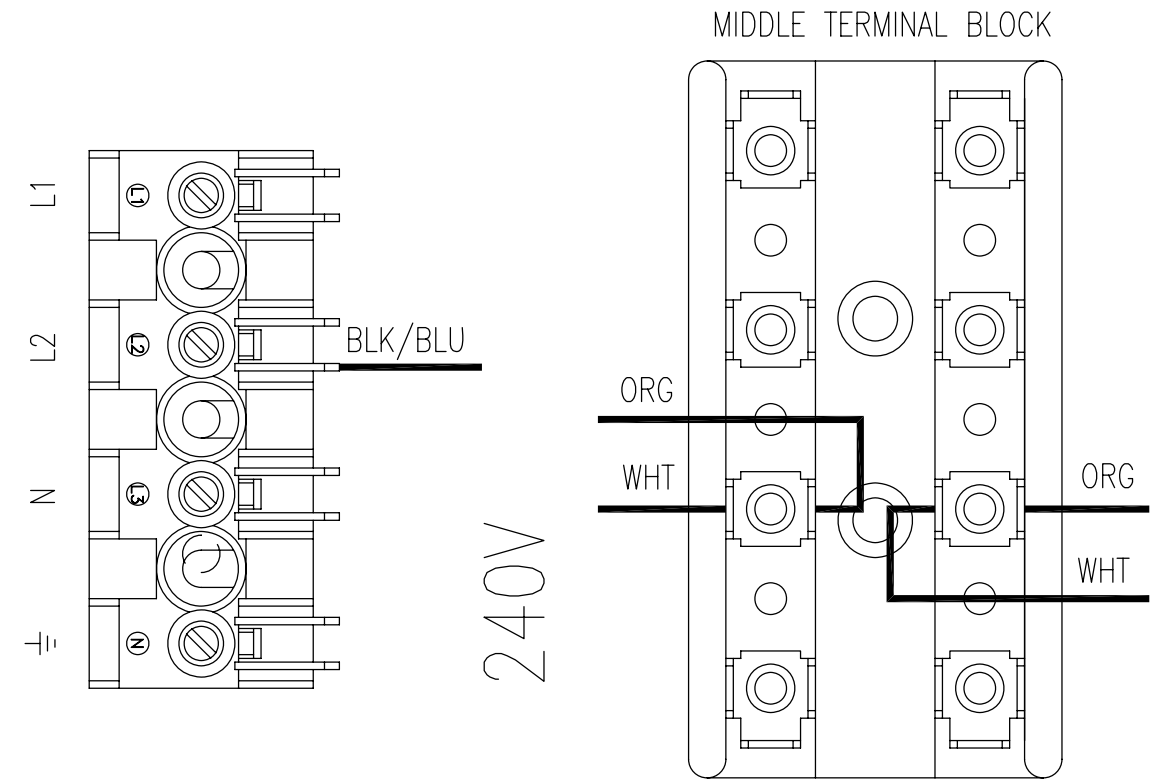

Figure 1 Middle Terminal Block



**DUAL VOLTAGE STACK DRYER
VOLTAGE CONVERSION**

50HZ Wiring Schematic Dryer Idle - No Coins Added

Top Dryer Used For This Example

230 VAC 50 HZ is supplied to the Main Power Terminal Block and passes through a In- line Noise Filter and comes out on BLK/RED and BLK/BLU wire. 230 VAC now passes to a Multitap Control Step Down Transformer and also passes to the Motor Control Relay (R1&R2). When there is power to the dryer the Computer Board will be powered and the display lighted from the 24 VAC secondary side of Control Step Down Transformer. 24 VAC from here is also on one side of the door switch on a black wire. Closing the loading door allows 24 VAC to pass on to the Computer Board on two blue wires. One blue wire makes 24 VAC available to one side of the Motor Run Relay on Computer Board. The other blue wire provides a 24 VAC signal to the Computer Board telling it that the door is closed and door light on the computer board should be illuminated.

Coins Added - Motor Starting and Running

Top Dryer Used For This Example

As each coin is added the Coin Switch closes and completes a circuit to the Computer Board. The Computer Board counts these signals and registers them against time. The time will display once the Start Button for Upper or Lower is pushed. When the Start Button is pushed again the Computer Board Motor Run Relay closes on the computer. With this Relay closed, 24 VAC is supplied to the Motor Control Relay (R1) on the red wire and also a violet wire going down to motor. The motor LED on the computer board should be illuminated anytime the computer calls for the motor to operate. With (R1) engaged and 230 VAC at motor the Motor Start Switch in motor is drawn in to the start position. In this position the incoming power 230 VAC is supplied directly to the main run winding and through the Start Capacitor to the Auxiliary Winding (start winding). As the Motor comes up to speed, the centrifical switch inside motor opens the circuit to the Start Winding and closes the circuit to allow 24 VAC to pass to the Gas Relay on the Computer Board on the other violet wire. The heat circuit in the dryer can not operate if the motor is not running. The gas LED on the computer board will be illuminated when Computer Board calls for the heat after Motor Centrifical Switch has closed.

Heat Circuit

Top Dryer Used For This Example

With the Drive Motor running and 24 VAC provided to the Computer Board Gas Relay, it will close if Computer Board senses programmed temperature is needed. The violet wire changes to an orange wire out of the Computer Board Gas Relay. When this relay closes it provides 24 VAC to the High Limit Thermostat. The High Limit Thermostat is normally closed. (It will open, turning off the heat circuit, if the dryer can't move enough air from problems such as an exhaust restriction or other problems.) 24 VAC now goes through to the normally open Air Switch (Sail Switch) on the brown wire. This switch is closed only if the dryer is running and has the correct air flow. With the dryer running and the Air Switch closed, 24 VAC is supplied to the normally closed upper manual reset Overtemp Thermostat on the gray wire and changes to the black wire out of switch and then goes to Ignition Step Down Transformer. Now with 24 VAC the red wire on secondary side of the Ignition Step Down Transformer goes to the 1.5 amp in-line fuse that protects the Upper Ignition Controller (GREY BOX). With 24 VAC now supplied to the Upper Ignition Controller (GREY BOX) it will then send high voltage to the Spark Ignition Electrode via the High Voltage Lead Wire (this lead looks like an automotive spark plug wire). The Ignition Control Module (GREY BOX) simultaneously sends 24 VAC to the Gas Valve Coil which opens the Gas Valve and allows gas to pass to the main burner. When ignition occurs the high voltage sparking stops and if Ignition Control Module (GREY BOX) gets a flame sense signal it will allow gas valve coil to remain energized and continue burner operation. If ignition does not occur, the Ignition Control Module (GREY BOX) will spark for 10 seconds before locking out.

Manual Reset Safety Shutoff Over-Temperature Thermostat

Top Dryer Used For This Example

This thermostat is manually reset by pushing in the red button through the small hole in the cover. The Over Temperature Thermostat is a safety backup for the entire Heat Circuit and located in the recirculation chamber area on the side of the burner housing. If the dryer over heats this Over Temperature Thermostat it opens the line to turn off the heat but leaves the Computer Board lighted and the drive motor powered and turning so the basket will cool down.

Cool Down

Top Dryer Used For This Example

At the preprogrammed time (2 minutes factory setting - adjustable) the Computer Board will open the Gas Relay Contact. This allows the Drive Motor to continue to run but without heat. The gas light on the computer board should not be illuminated anytime the computer is in cool down. This Cool Down period allows the clothing (zippers, snaps, etc.) time to cool down to a temperature that is easily handled by customers.

End of Cycle

Top Dryer Used For This Example

At the end of the cool down, the Computer Board opens the Upper Run Relay, which removes power from the Motor Control Relay (R1) and also removes power to the Drive Motor. The motor light on the computer board should no longer be illuminated. The Drive Motor and tumbler stops and the Computer Board display now flashes until the dryer loading door is opened. Once the dryer loading door is opened to remove the clothing the display goes back to vend price.

50 Hz Parts - Electrical Group

Key	Part Number	Description	Quantity
2	5192-295-017	Relay	2
*	8220-065-006	Wire Asy-BLK/RED, 11"	2
*	8220-065-007	Wire Asy-BLK/BLU, 11"	2
*	8220-065-032	Wire Asy-BLK, 11"	2
*	8220-065-033	Wire Asy-WHT, 11"	2
*	8220-095-043	Wire Asy-BRN, 81"	2
*	8502-730-001	Label-Warning, Electronic Coin Acceptor	1
*	8507-230-003	Instructions-Transformer Connect	1
3	8711-008-002	Transformer-Control	1
4	9183-030-002	Filter-Line, EMI	1
*	9376-314-001	Motor-Dryer, Stack, Marathon	2
*	9486-149-001	Retainer-Dual Coin Acceptor	2
*	9506-332-001	Wiring Label-Schematic	1
*	9506-333-001	Wiring Label-Diagram	1
6	9558-029-004	Strip-Marker, Terminal	1
*	9627-868-002	Harness-Main input power	1
*	9627-871-001	Harness-Motor Extension	2
*	9627-878-001	Harness-Ignition Control, Upper	1
*	9627-878-002	Harness-Ignition Control, Lower	1
5	9857-140-001	Ignition Control	2
*	9857-147-002	Control Assembly, Elec. Mounted w/ Membrane Switch	1

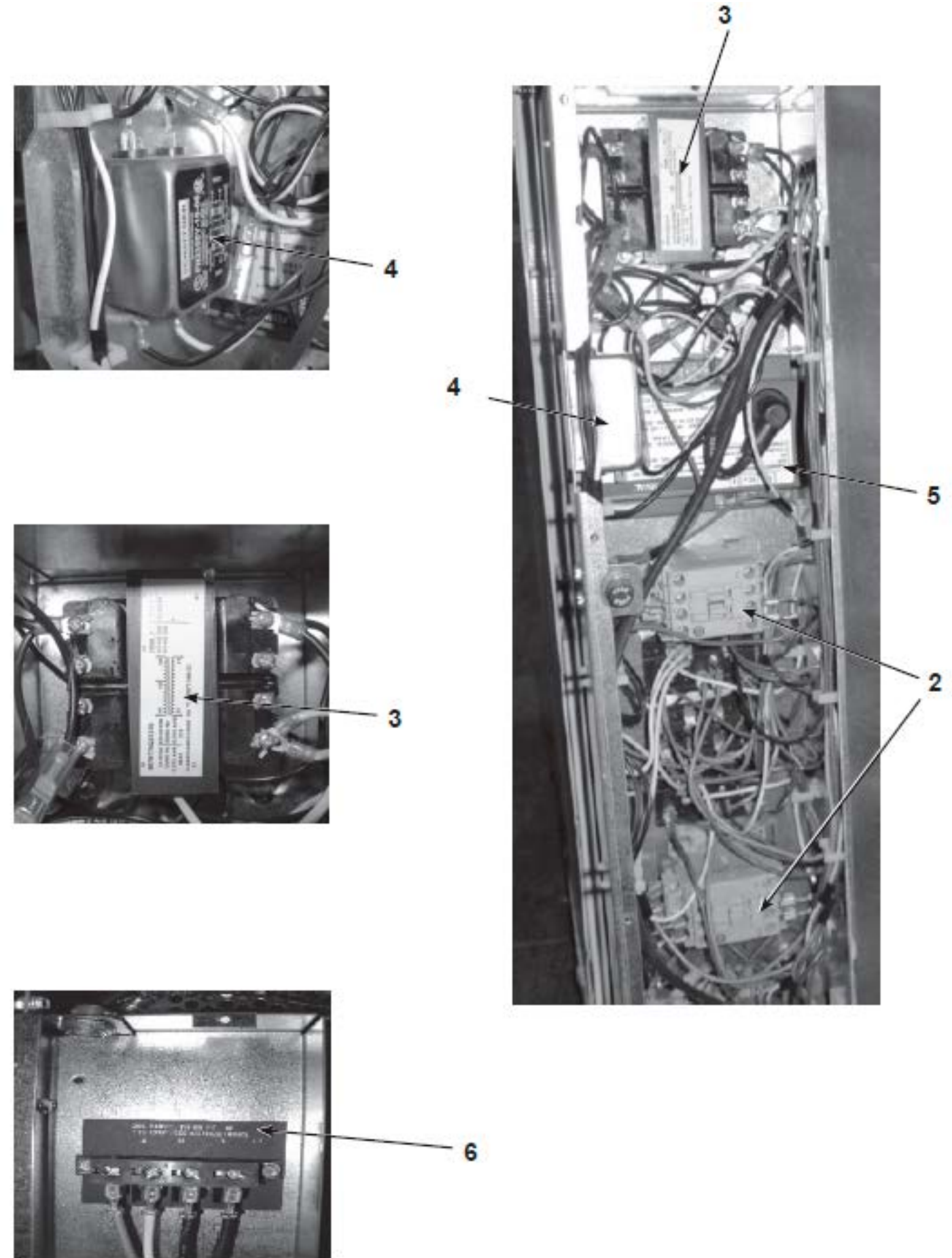

DDAD30KC_-59_ Gas Control Parts

Key	Part Number	Description	Quantity
1	9732-162-001	Kit-Honeywell VR86 Valve Flange.....	4
*	9791-001-001	Adapter Assembly-Gas Inlit	1
2	9857-132-004	Gas Control Valve.....	2



IMPORTANT: RETAIN THIS ELECTRICAL SCHEMATIC FOR SERVICE.

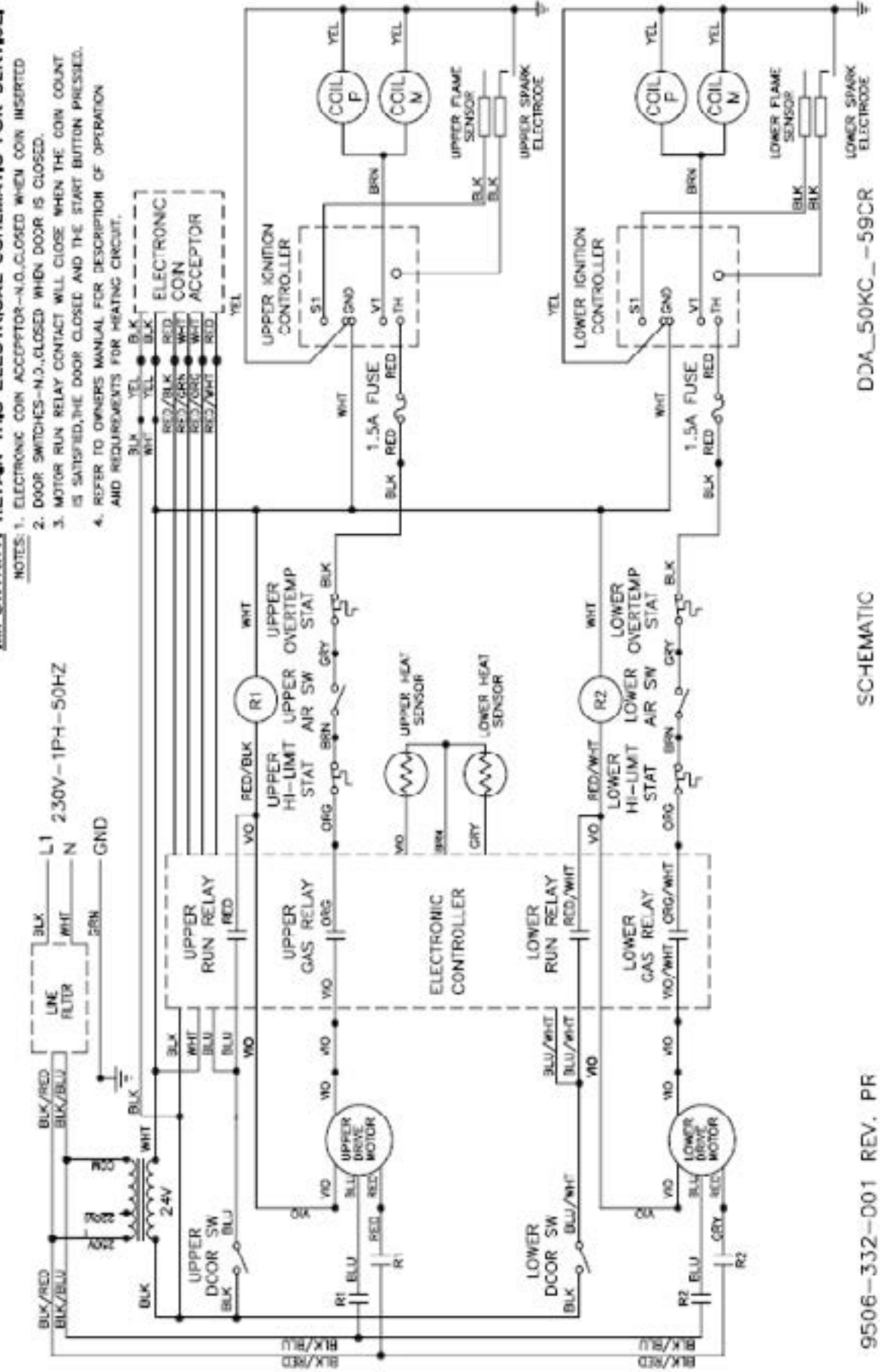

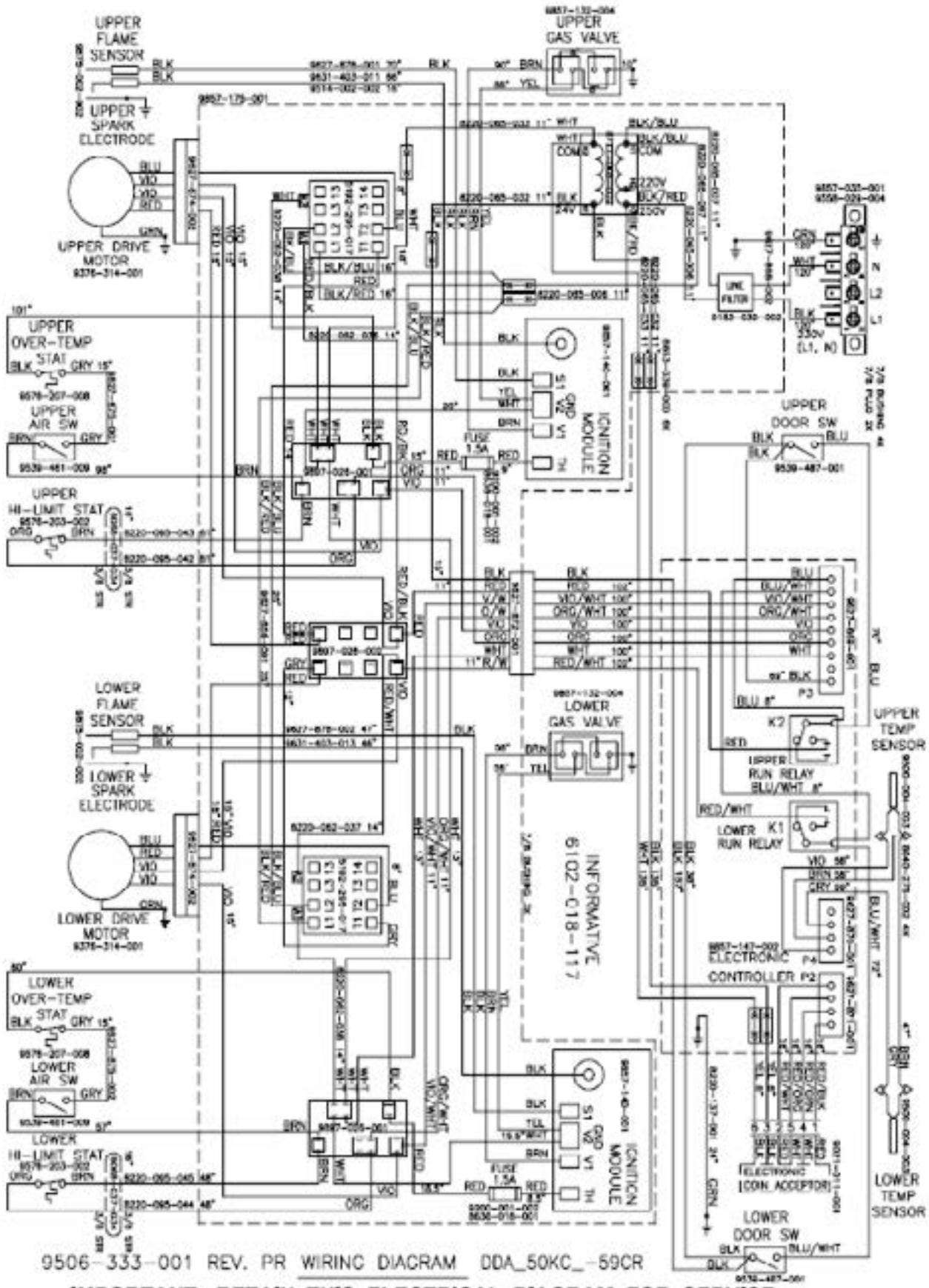

9506-333-001 REV. PR WIRING DIAGRAM DDA_50KC_-59CR

IMPORTANT: RETAIN THIS ELECTRICAL DIAGRAM FOR SERVICE.