



DEXTER[®]
LAUNDRY

**USE THE BLUE TABS LOCATED ON THE
RIGHT AND LEFT SIDES OF THE FOLLOWING
DOCUMENT TO ADVANCE TO EACH SECTION.**

Kits, Assemblies, & Common Parts

DDAD30HC_-11

Loading Door Components	Part Number
Door Handle	9244-082-001
Door Close Switch	9539-487-001
Electrical Components	Part Number
Relay, Motor Run (24VAC)	5192-298-002
Transformer, Ignition/Control	8711-014-001
OPL Controls (Blue)	9857-187-001
OPL Controls (Black)	9857-187-003
Heating Circuit Components	Part Number
Ignition Control Module	9857-116-003
Ignition Electrode Assembly	9875-002-003
Thermostat, Hi-Limit	9576-203-002
Thermostat, Overtemp	9576-207-008
Fuseholder	9200-001-002
Fuse 1.5 amp	8636-018-001
Fuse 2.5amp	8636-018-004
Airflow Switch	9539-461-009
Cabinet Components	Part Number
Cleanout Duct Assembly 8"	9973-034-001



Section 6: Parts Data 30# Stack

Cabinet Group - 30lb

Key	Part Number	Description	Quantity
*	9960-256-032	Door Assy., Loading Complete-Wht	2
*	9960-256-034	Door Assy., Loading Complete-SS	2
1	9960-255-008	Door Assy., Loading-SS(ring only)	2
2	9982-280-014	Plate Assy., Hinge (Wht) No Pin	2
2	9982-280-012	Plate Assy., Hinge (SS) No Pin.....	2
*	9545-012-015	Screw, Hinge to Door	8
*	8640-413-002	Nut, Hinge to Door	8
3	9212-002-003	Glass, Door	2
4	9206-164-009	Gasket, Glass (Gray).....	2
4	9206-413-001	Gasket, Glass (Black).....	2
*	9548-117-000	Support, Door Glass	2
5	9206-420-002	Gasket, Outer Rim (Gray)	2
5	9206-420-003	Gasket, Outer Rim (Black)	2
6	9244-082-001	Handle, Loading Door	2
*	9545-018-017	Screw, Handle 1/4-20 x 3/8	2
*	9531-033-001	Stud, Door Catch	2
*	8640-413-001	Nut, Hex	2
*	8640-413-003	Nut, Acorn	2
*	9086-015-002	Catch, Loading Door	2
*	8638-190-009	Pop Rivet for mtg. catch	4
*	8641-582-019	Lockwasher	4
*	8640-399-001	Spring Nut	6
7	9989-516-011	Panel Assy., Front- Lower (Wht)	1
7	9989-516-010	Panel Assy., Front- Lower (SS)	1
8	9989-513-015	Panel Assy., Front- Upper (Wht)	1
8	9989-513-013	Panel Assy., Front- Upper (SS)	1
9	9545-008-020	Screw, Torx HD 10 x 3/4.....	14
9	8541-582-019	Lockwasher	6
*	8640-399-001	Nut, Spring	12
10	9544-047-002	Strap, Hinge (Wht)	2
10	9544-047-007	Strap, Hinge (SS/Gray)	2
*	9545-012-028	Screw, Hinge to Panel	8
11	9545-052-001	Screw, Door to Hinge Strap (Special Black Type)	2
*	8641-436-003	Washer, Fiber	2
*	9472-001-013	Cabinet Touch Up Paint (White).....	1



Cabinet Group - 30lb (continued)

Key	Part Number	Description	Quantity
14	9994-030-002	Escutcheon, Upper	1
15	9435-026-001	Trim, Overlay-Upper (Blue).....	1
15	9435-034-001	Trim, Overlay-Upper (Black)	1
16	9994-031-001	Escutcheon, Lower	1
17	9435-020-001	Trim, Overlay-Lower (Blue).....	1
17	9435-028-001	Trim, Overlay-Lower Black)	1
18	9412-154-001	Nameplate Stack Dryer Express (Blue).....	1
18	9412-167-001	Nameplate Stack Dryer Express (Black)	1
21	8650-026-002	Lock, Thumb Turn	2
22	9857-187-001	Controls Assy, Electronic Mounted With Membrane Switch (Blue) .	1
22	9857-187-003	Controls Assy, Electronic Mounted With Membrane Switch (Black) 1	
22	9801-096-001	Membrane Switch Assy (Blue)	1
22	9801-105-001	Membrane Switch Assy (Black).....	1
23	8650-012-003	Lock and Key, Control #6324	1
24	9501-006-002	Sensor Temp Control	2
24	9486-137-002	Retainer - Push On.....	2
25	9866-004-010	Lint Drawer Assembly (Blue)	2
25	9866-004-013	Lint Drawer Assembly (Black).....	2
25	9435-003-009	Overlay trim, lint dwr, upper/lower (Blue)	1
25	9435-029-002	Overlay trim, lint dwr, upper/lower (Black).....	1
*	9545-020-009	Screw.....	10
*	9532-074-003	Felt Seal (back of lint screen assembly)	2
*	9805-029-002	Lint Screen Assembly ONLY (no front)	2
*	9555-057-002	Replaceable Lint Screen Only	2
*	9095-044-001	Cam, Lock Lint Drawer	2
*	9545-008-001	Lint Screen Strap Hold Down Screws 10Bx 1/4	32
*	9627-885-001	Harness, Electronic Control	1
*	9095-041-001	Cam, Lock Control.....	1
*	6292-006-007	Key 6324 only for Computer.....	2
*	9627-886-001	Harness, Heat Sensor	1
*	9277-041-011	Insulation Cabinet Cover	1
*	9209-037-002	Grommet, 3/16 ID	2
*	8544-006-001	Leg, Leveling 1/2"	4
*	8545-060-002	Leveling Leg Wrench.....	1
*	9074-261-001	Cover, Cabinet (Top).....	1
*	9732-102-011	LP Kit for DDAD Dryers.....	1
*	9732-243-001	Stack Dryer Trunion Puller	1
*	9555-057-003	Replaceable Lint Screen Fine Mesh Only	1
*	9277-053-001	Insulation-Front Panel-Top Half	2
*	9277-053-002	Insulation-Front Panel-Lower Half.....	2
*	8640-276-002	Wire Nut Connector Grey.....	4
*	9527-007-002	Standoff Wire Saddle.....	8
*	9544-041-002	Strap - Bead Tie.....	1



Door Switch Group - 30lb

Part Number	Description	Quantity
9539-487-001	Door Switches	2



Hinge Plate Cover (after Serial # 220625)

1	9074-341-002	Cover-Hinge, Black	2
Note: Before Serial # 220625 Holes can be drilled in hinge plate to install (#18 Drill bit).			
2	8636-018-001	Screw-TRHDCR, 10B x 3/8, Black.....	4

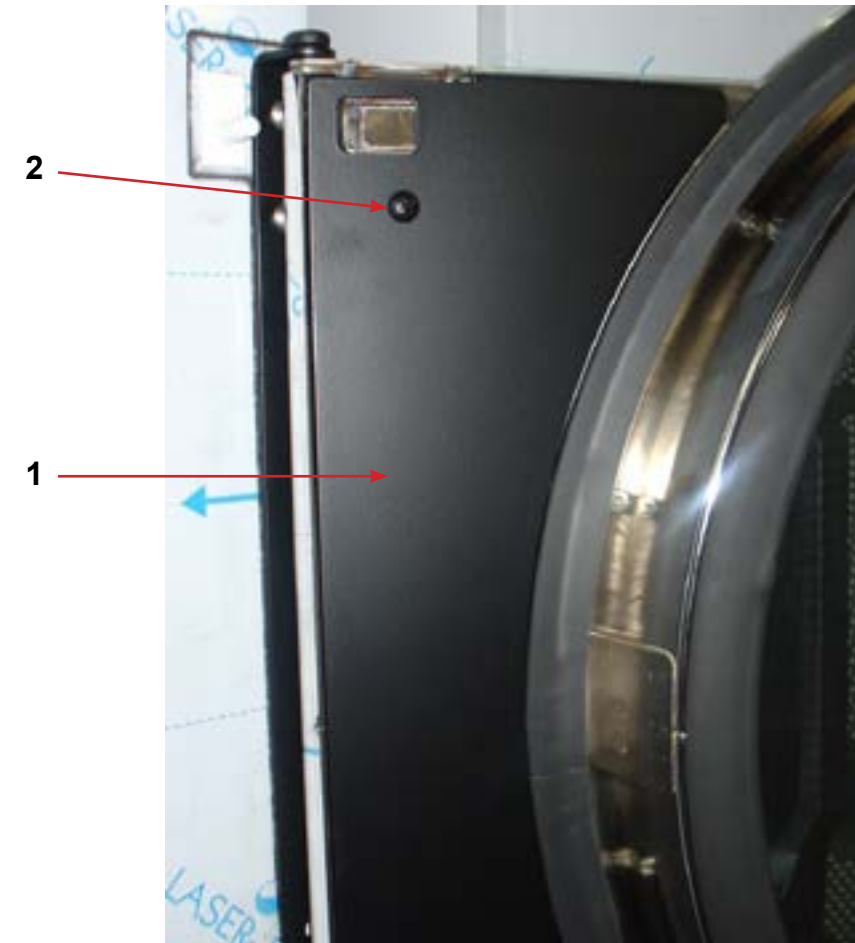

Bearing Housing Group - 30lb

Key	Part Number	Description	Quantity
J1	9241-161-002	Housing, Bearing	2
J2	9036-130-001	Bearing, Ball	4
*	9538-139-002	Spacer, Bearing	2
J5	9545-049-001	Screw, 3/8 x 1.....	4
J6	8640-415-002	Nut, 3/8.....	4
J7	8640-400-002	Nut, 5/16.....	8
*	9803-160-003	Bearing Housing Complete Ass'y (includes bearings,spacer)	2
J4	9545-049-002	Screw 3/8 x 3/4.....	8

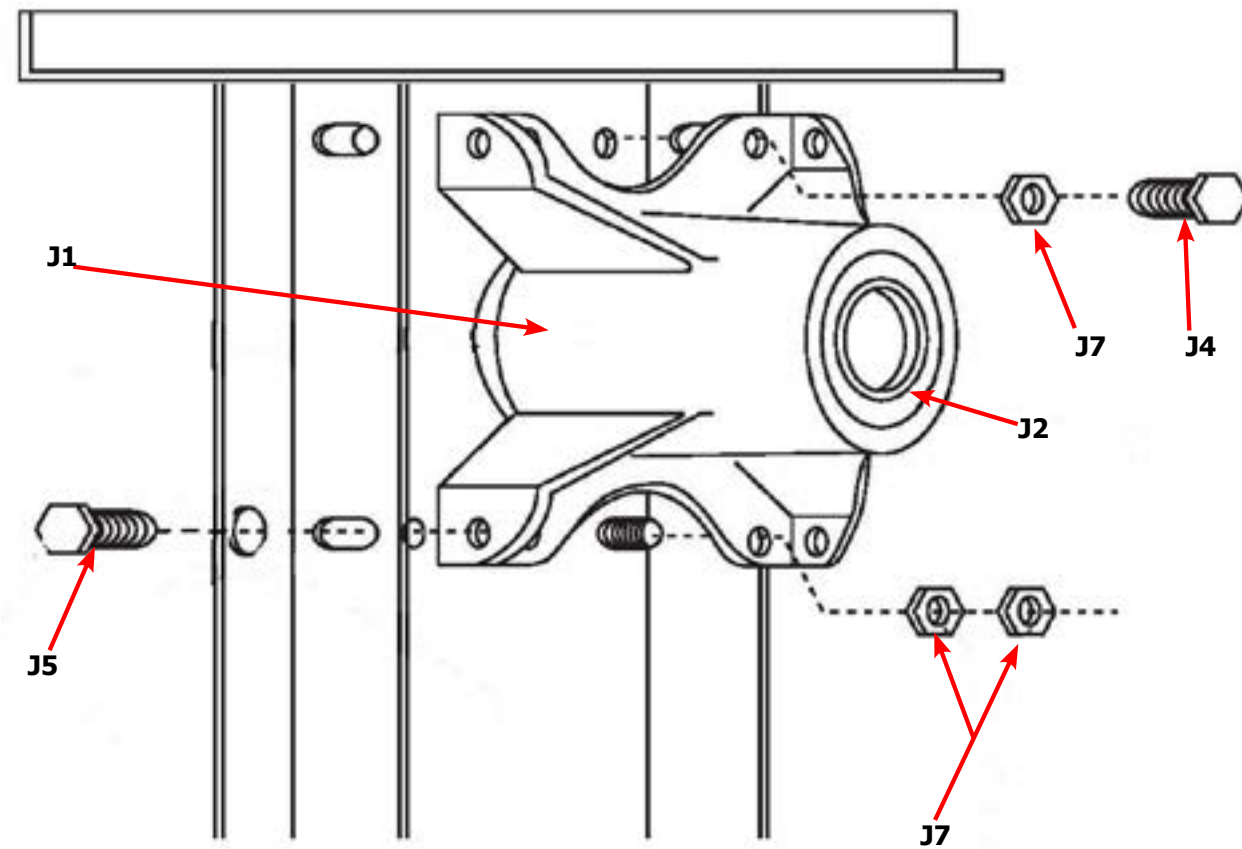

Tumbler Group - 30lb

Key	Part Number	Description	Quantity
*	9848-127-001	Tumbler Assembly Galvanized w/ Spider	2
*	9848-127-002	Tumbler Assembly Stainless w/ Spider	2
G2	9568-011-001	Spider Assembly	2
G3	9497-019-003	Rod, Tumbler	6
G4	8640-415-004	Nut, 3/8" - 16	6
G6	8641-554-001	Washer, Special	6
G7	9552-013-003	ShimAR
*	9848-126-002	Tumbler Assembly Stainless Steel Only	2
*	9848-126-001	Tumbler Assembly Galvanized Only	2

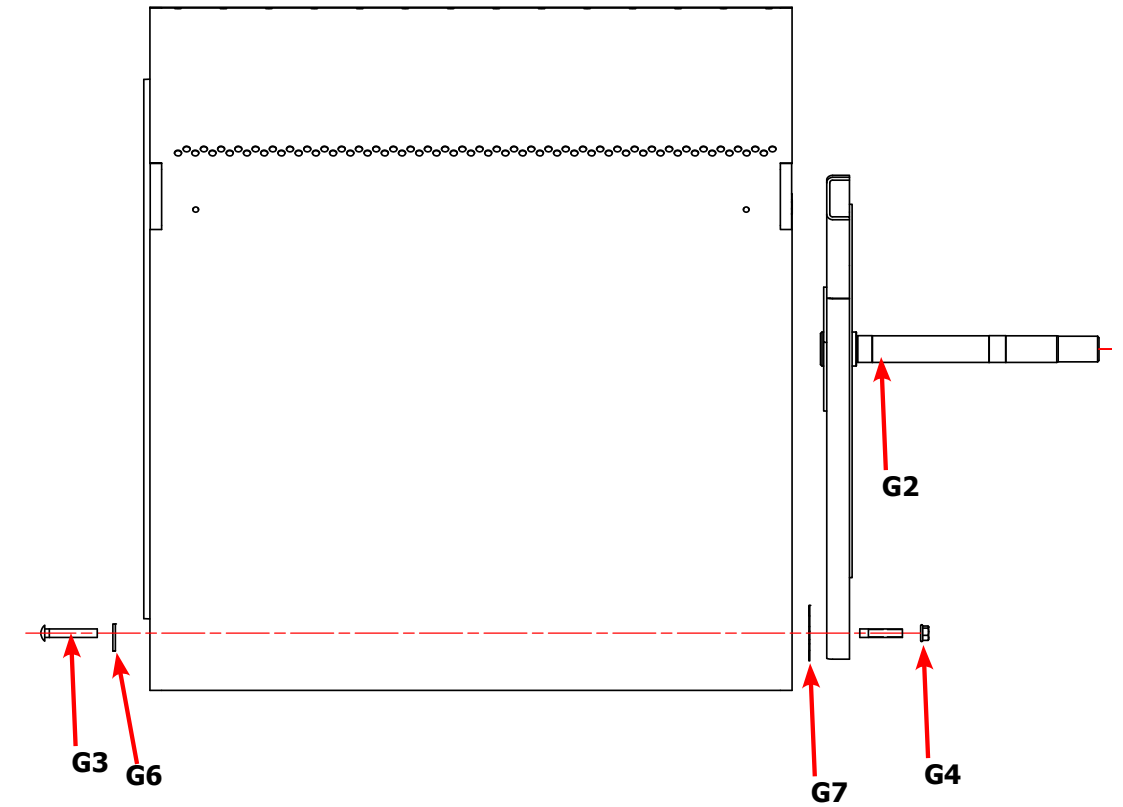

Bearing Housing Group After serial #226213

Key	Part Number	Description	Quantity
*	9803-160-003	Bearing Housing Complete Assy (Includes bearings & Spacer).....	1
1	9241-161-002	Housing, Bearing.....	1
*	9036-130-001	Bearing, Ball, Front	1
*	9538-139-002	Spacer, Bearing.....	1
2	9036-130-001	Bearing, Ball, Rear	1
3	9545-049-002	Screw-Wizlock, 3/8-24x3/4	4
4	8640-400-002	Nut, 5/16-18.....	4
5	9545-049-001	Screw, 3/8-24x1.....	2
6	8640-415-002	Nut, 3/8-24.....	2
*	9538-139-002	Shim, Tumbler	AR

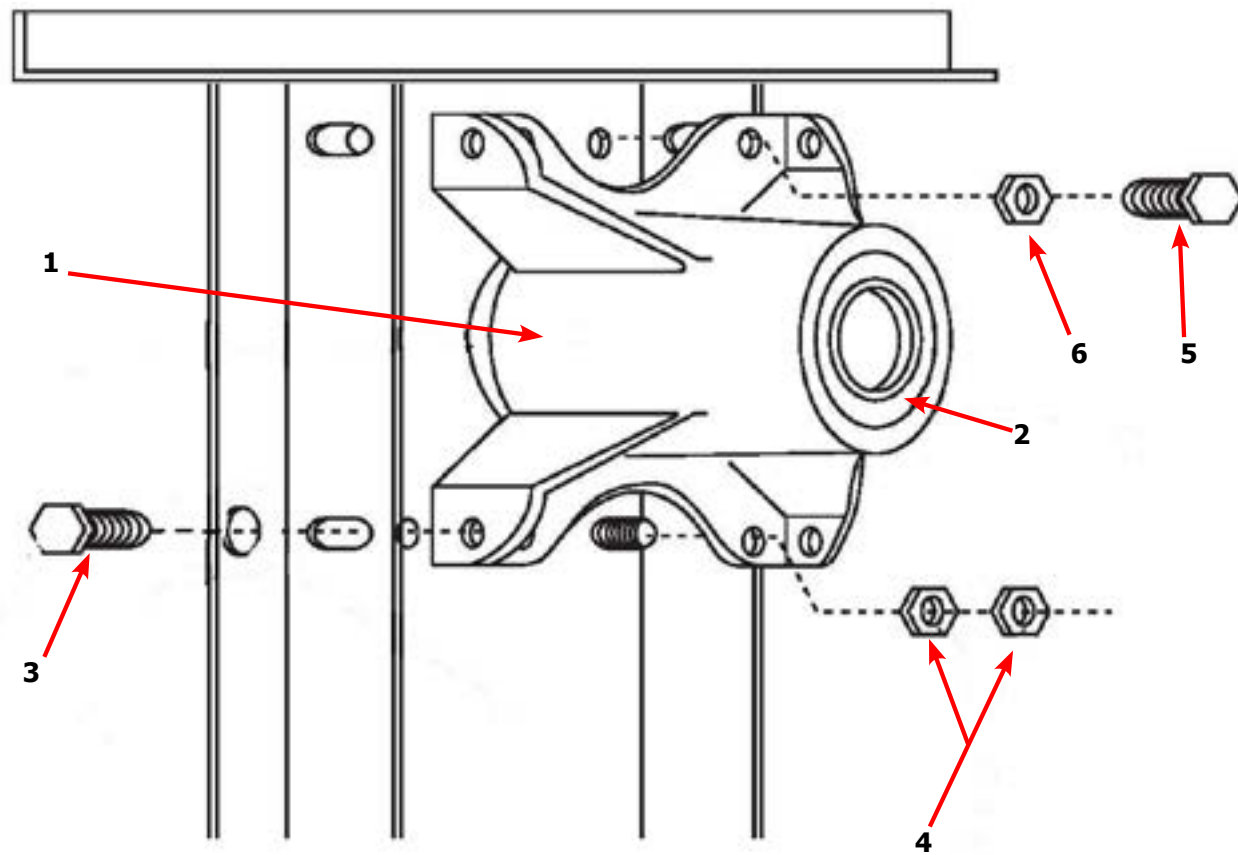

Tumbler Group After Serial #226213

Key	Part Number	Description	Quantity
*	9848-142-001	Tumbler Assy Complete W/Spider (GALV).....	1
*	9848-142-002	Tumbler Assy Complete W/Spider (SS & Galv front)	1
1	9848-126-001	Tumbler Assy (Galvanized).....	1
1	9848-126-002	Tumbler Assy (Stainless Galvanized front)	1
2	9497-019-003	Rod, Tumbler.....	3
3	8641-554-001	Washer, Special.....	3
4	9552-013-000	Shim	AR
5	9568-015-001	Spider Assy.....	1
6	8640-415-004	Nut, Wiz Lock	3
7	9538-164-001	Spacer-Shaft.....	1
8	9487-234-005	Tolerance Ring.....	1
9	9908-049-002	Pulley, Driven.....	1
10	8641-581-026	Washer -Flat.....	1
11	8641-582-016	LockWasher - IntTooth, 1"	1
12	9545-017-009	Screw, 1/2-13x1 1/4.....	1

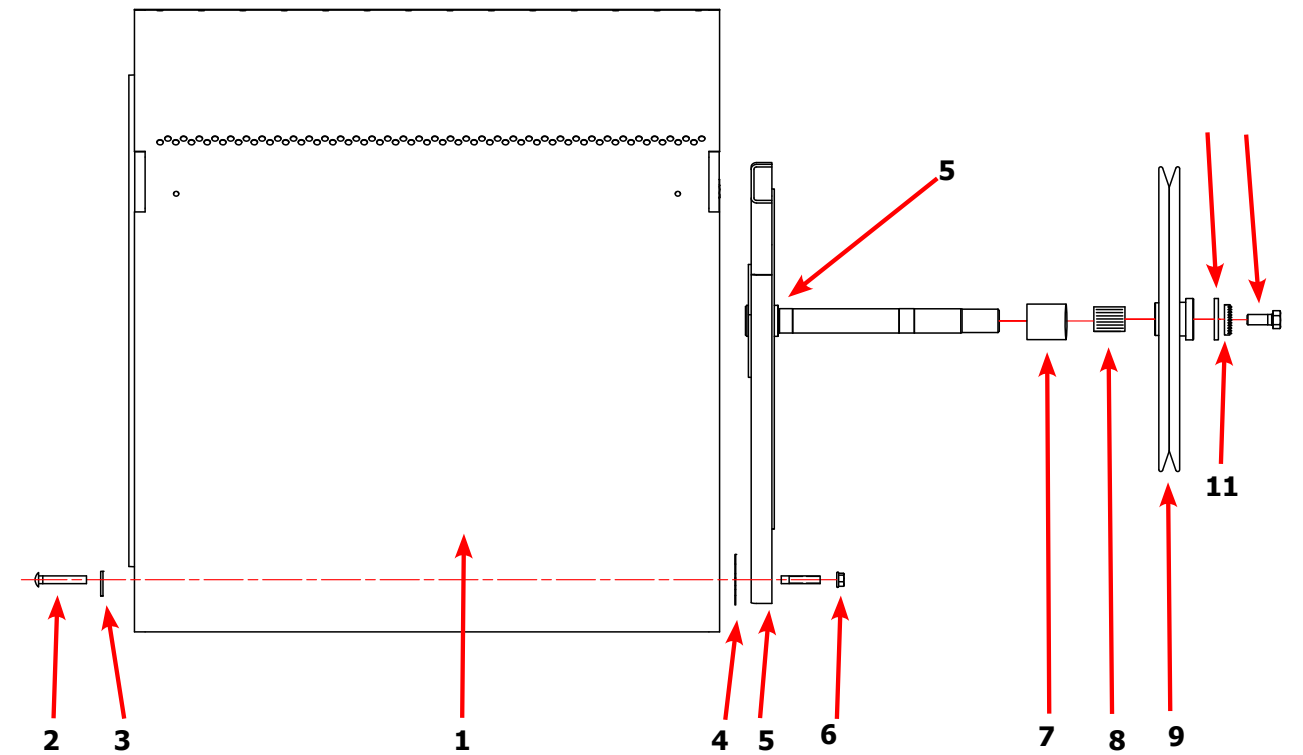

10, 11, 12

Burner Housing Group - 30lb

Key	Part Number	Description	Quantity
1a	9452-730-001	Service Burner Plate Front...	2
1	9452-729-001	Service Plate baffle Recirculation Chamber Clean Out	2
2	9545-008-001	Screw	16
18	9003-220-001	Angle, Burner Support	2
17	9048-020-001	Burner, Main	4
4	9545-008-001	Screw 10B x1/4"	8
5	9875-002-003	Electrode Assy, Ignition	2
19	9545-045-001	Screw, Electrode Mtg 8B x 1/4"	4
7	9379-186-001	Valve, Gas Shut Off (Optional)	1
8	9857-134-001	Control Assy, Gas	2
9	9381-012-001	Manifold, Assy 2 Part 1 Piece	2
22	8615-104-038	Pipe Plug in end of Burner Manifold	2
11	9452-749-001	Plate Assy, Hi-Limit Stat Ignitor	2
12	9576-203-002	Thermostat, Hi-Limit	2
13	9074-315-001	Cover, Hi-Limit Stat Ignitor	2
15	9825-058-001	Cover, Safety Stat	2
16	9857-116-003	Control, Ignition Fenwall (3 trybox)	2
*	9803-199-001	Housing Assembly, Burner	2
*	9545-008-006	Screw 10AB x 3/8"	4
*	9454-816-001	Panel, Back Burner Housing	2
*	9425-069-023	Orifice, Burner-Natural #125	4
*	9425-069-024	Orifice, Burner-LP #49	4
*	9039-915-001	Bracket, Gas Control	2
*	9545-008-006	Screw	4
*	9538-142-001	Spacer, Hi-Limit	4
*	9545-045-007	Screw 8B x 3/4"	4
*	9545-008-006	Screw	6
*	9576-207-008	Thermostat, Safety Shutoff	2
*	9545-008-006	Screw	4
*	9545-008-006	Screw	4
*	9550-173-001	Shield, Burner Inlet	1
*	9732-102-011	Kit, LP Conversion DDAD Kit	2

^ Models built before 9/07

Burner Housing Group Photos - 30lb

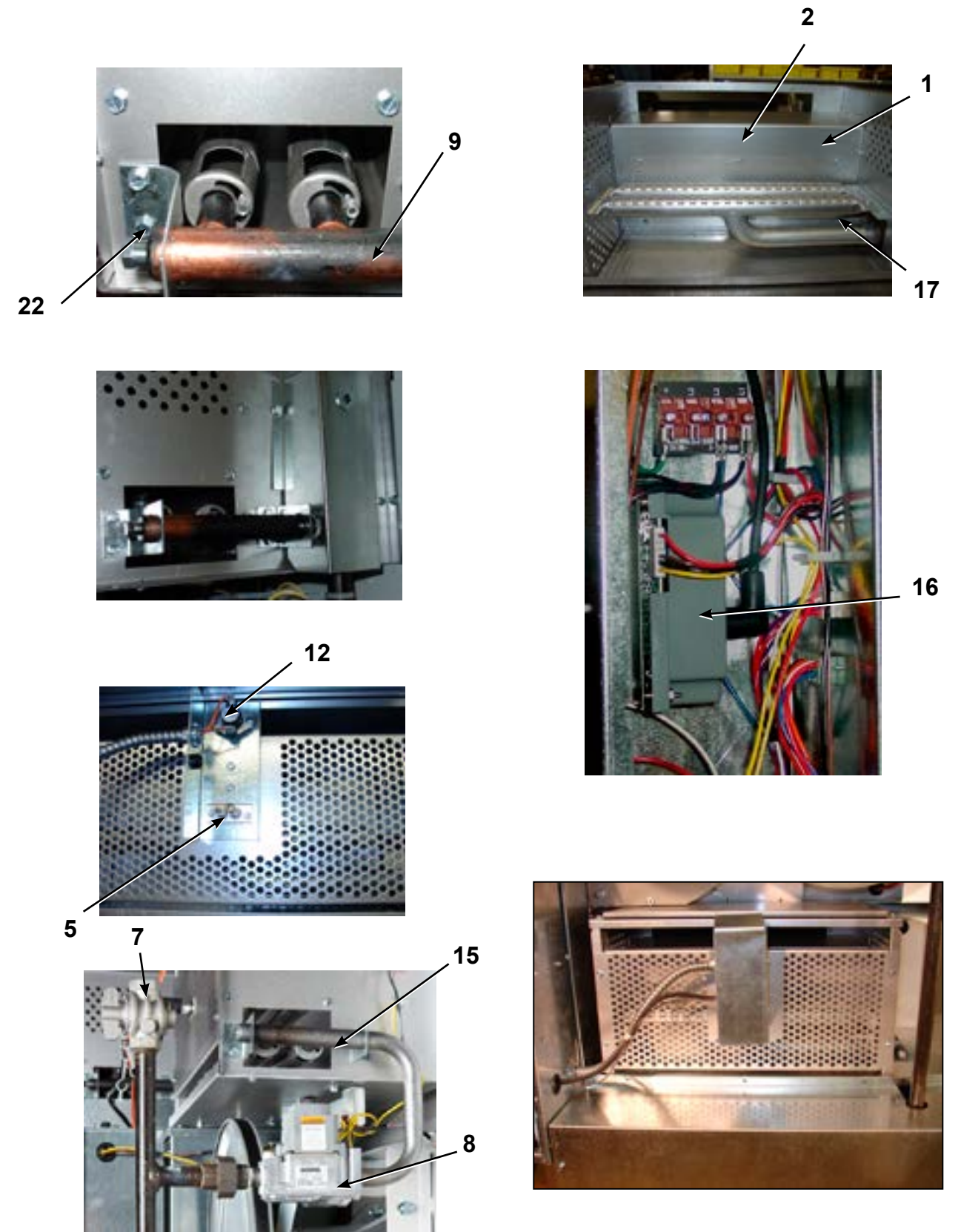

Rear View - 30lb

Key	Part Number	Description	Quantity
*	9627-861-001	Wire Harness Overtemperature Switch.....	2
*	9801-095-001	Switch Assy, Air Flow	2
1	9539-461-009	Switch, Air Flow.....	2
2	9029-174-001	Bracket, Switch- Air Flow	2
3	9008-007-001	Actuator, Switch	2
4	9451-169-002	Pin, Cotter	2
5	9545-020-001	Screw 4-40 x 5/8"	4
*	8640-401-001	Nut, Special Twin .#4-40.....	2
*	9550-169-003	Shield, Switch.....	2
*	9545-008-001	Screw 10 Bx 1/4"	6
7	9376-309-003	Motor, Drive.....	2
*	9732-205-002	Motor Kit	2
8	9452-740-001	Plate, Motor Mtg.....	2
*	9545-029-008	Bolt 3/8" - 16 x 3/4".....	8
*	8641-582-003	Lockwash Spring 3/8	8
9	9545-018-019	Screw, Motor Plate to Back Assy. 1/4-20x 2 1/2	8
9	86411-582-007	Lockwasher 1/4.....	8
9	9538-163-006	Spacer.....	8
9	8641-581-017	Flat Washer 1/4 x 7/8.....	24
9	9209-086-002	Rubber Grommet.....	8
*	9538-166-006	Grommet Spacers.....	8
*	9545-028-013	Screw, Set	4
10	9962-017-002	Back Assy, Blower Hsg.....	2
26	9278-039-001	Impeller, W/Set Screws.....	2
11	9991-053-001	Support Assy, Intermed. Pulley	2
12	9545-029-010	Bolt, Rd Hd 3/8-16 x 1 1/4.....	6
13	9545-029-003	Bolt, 3/8-16 x 1 1/2.....	2
12	8640-415-004	Nut Flange Wziocok 3/8" - 16	6
12	8641-581-035	Washer, Flat.....	6
14	9861-022-001	Arm Assy-Tension, Complete	2
*	8641-581-035	Washer, Flat.....	2
15	9487-200-003	Ring-Retaining	6
16	9908-039-004	Pulley Assy, Intermediate with bronze flange bearing.....	2
*	9036-145-002	Bearing - Bronze Flange.....	4
17	9908-040-001	Pulley Driven.....	2
*	9306-006-000	Key Tumbler Shaft Woodcuff	2
*	8640-222-000	Nut Hex 1" - 14	2
*	8641-582-015	Washer Lock	2
*	9538-164-001	Spacer, Shaft	2
18	86A1-582-015	Washer, Lock	2
19	9040-077-001	Belt, Drive- Motor.....	2
20	9040-073-009	Belt, Drive- Tumbler	2
21	9534-319-002	Spring, Tension	2
22	9099-012-002	Chain, Tension.....	2
23	9248-022-002	Hook, Tension	2
*	9125-007-001	Damper Inside Duct Exhaust Upper	1
24	9451-146-001	Pin, Damper Hinge	2
*	8520-141-000	Nut, Spring	4
*	9425-007-002	Damper, Inside Duct Exhaust Lower	1
*	9545-008-026	Screw #10B x 1/2.....	6
25	9074-338-001	Cover Duct Upper.....	1
*	9074-339-001	Cover Duct Lower.....	1
*	9545-008-026	Screw 10ABx 1/2".....	14
25	9973-033-001	Heat Recirculation Assembly Duct.....	2
27	9453-157-001	Motor Pulley - Driver.....	1
*	9029-173-001	Bracket for Wire Harness Under Burner Housing.....	2
*	9545-008-024	Screw 10 AB x 3/8	58

Rear View Photos - 30lb

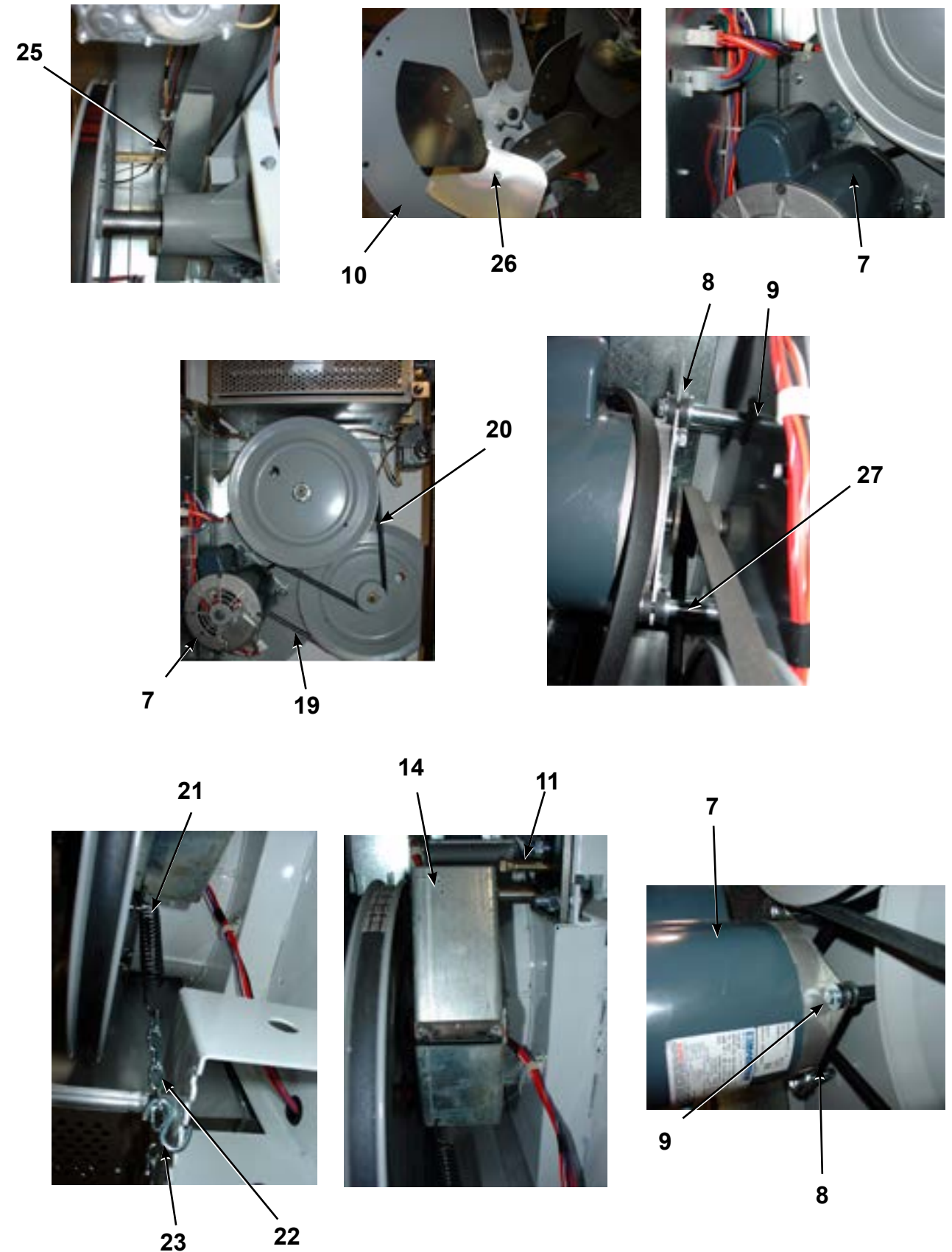

Rear Panel & Cover Group - 30lb

Key	Part Number	Description	Quantity
1	9208-083-001	Back Drive Guard Panel.....	2
*	9545-008-024	Guard Screws.....*	
2	9208-076-001	Back Side Guard Panel Ass'y.....	2
3	9074-261-001	Cabinet (TOP COVER).....	1
*	8544-006-001	Legs Leveling.....	4
5	9545-008-024	Screws 10 AB x 3/8.....	4
6	9577-062-001	Top Duct w/ Oval.....	1
4	9108-117-001	Electric Box Cover w/ Hinge.....	1
*	9545-008-024	Screws, Electronic Box Cover.....	3
*	9973-034-001	8" Slide Open Clean Out Duct (Optional).....	1



OPL Control Board - 30lb

Key	Part Number	Description	Quantity
1	9857-187-001	Control Assembly (Blue).....	1
1	9857-187-003	Control Assembly (Black).....	1
2	9471-017-001	PCB Control Board.....	1
3	9471-018-001	PCB Display Board.....	1
4	9500-007-001	Cable, Upper Control Long.....	1
5	9500-007-002	Cable, Lower Control Long.....	1
6	9801-096-001	Membrane Switch Assembly (Blue).....	1
6	9412-167-001	Membrane Switch Assembly (Black).....	1
7	8636-024-001	Fuse, 600ma / 250v.....	2
*	9627-885-001	Harness Main Control OPL Stack Dryer.....	1

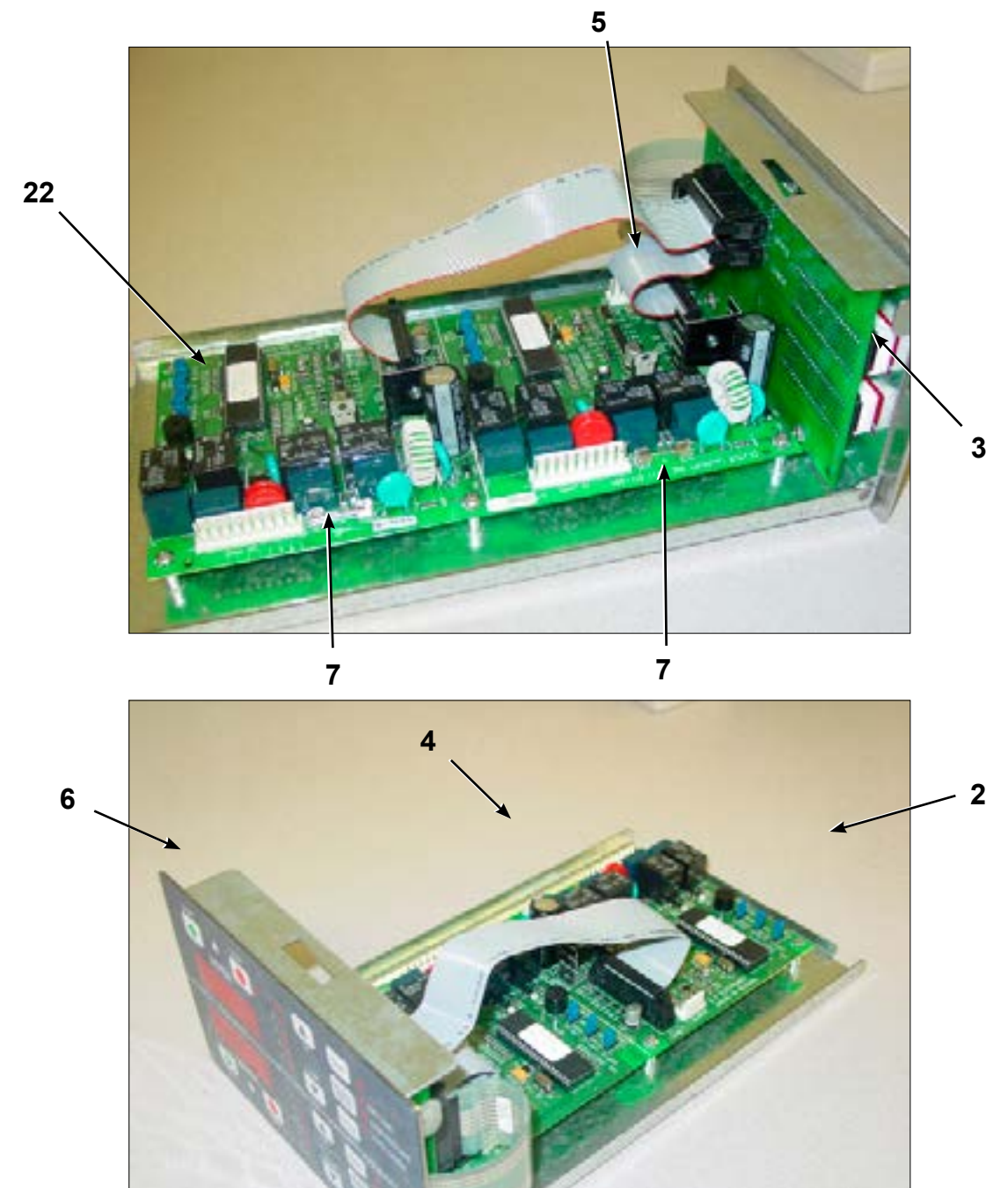

Control Assembly Group - 30lb

Key	Part Number	Description	Quantity
*	9108-117-001	Control Box Cover Door	1
*	8220-001-478	Wire Assembly Green 7"	1
3	9897-026-002	Terminal Block Main Power Middle	1
4	9897-026-001	Terminal Block.....	2
5	8711-014-001	Transformer Ignition	2
6	9982-348-001	Plate Assembly MTG Ignition Control.....	2
7	9857-116-003	Ignition Control	2
8	9631-403-009	Wire Assembly High Voltage Upper	1
9	9627-860-001	Wire Harness Ignition Control Upper	1
10	9627-860-002	Wire Harness Ignition Control Lower	1
11	9053-067-002	Bushing Wire 7/8"	4
12	8653-068-003	Connector Conduit 3/8" STR.....	1
13	9200-001-002	Fuseholder Assembly	2
14	8636-018-001	Fuse 1.5 Amp	2
15	5192-298-002	Relay Power 24 VAC.....	2
16	9897-035-001	Terminal Block Assembly Main Power Inlet	1
*	8220-062-036	Wire Assembly Red/Black 14"	1
*	8220-062-037	Wire Assembly Red/White 14"	1
*	8220-062-038	Wire Assembly White 14"	2
20	9627-859-001	Wire Harness - Power Main	1
21	9627-864-001	Wire Harness Motor Extension.....	2
22	9558-029-003	Strip Terminal Marker (Behind Input Power) to above #16	1
*	9857-169-005	Control Assmbly Complete (all below included)	1
*	8639-621-007	Screw # 10-32 x 12 Green	1
*	8641-582-006	Lockwasher Ext Tooth #10	1
*	9545-045-012	Screw #8 ABx1 2 for terminal block.....	6
*	9545-008-024	Screws 10AB x 3/8"	4
*	9545-008-001	Screws 10B x 1/4" MTG Above Plate.....	4
*	8640-411-003	#6-32 Screws.....	4
23	9631-403-008	Wire Assembly High Voltage Lower	1
*	9545-045-012	Screws Power #8 AB x 1/2"	6
*	9527-007-001	Stand Off - Wire Saddle / Arrowhead	17
*	9545-031-005	Screw 6 B x 3/8"	4
*	9627-887-001	Wire Harness Main Extension Access Under Burner Housing	1

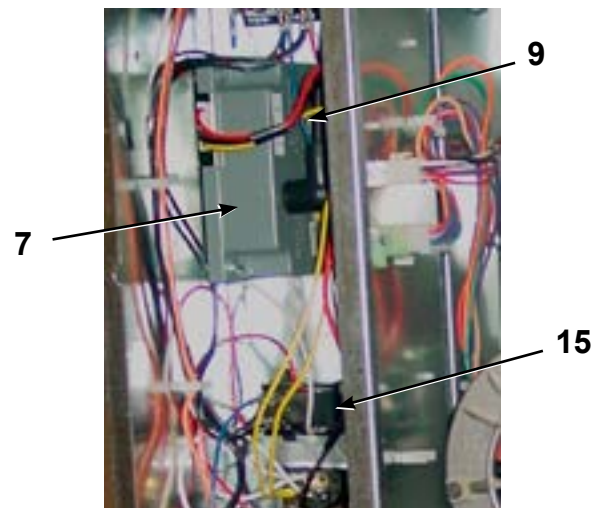
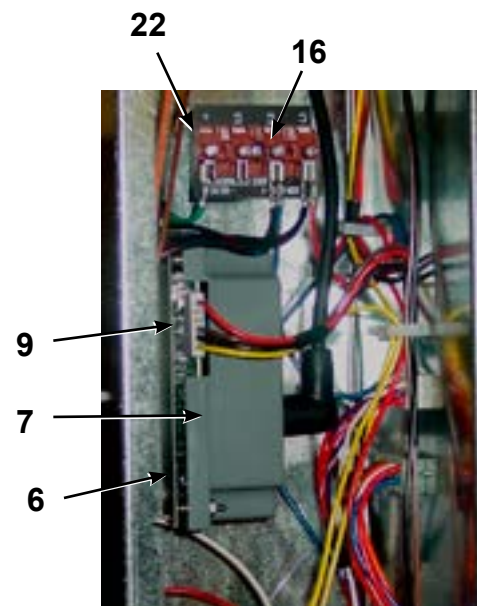

Control Assembly Group - 30lb

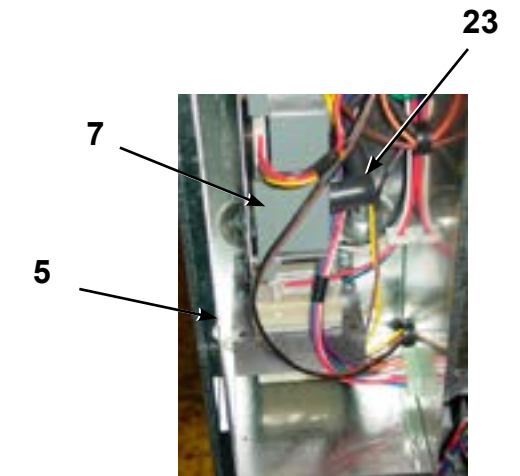
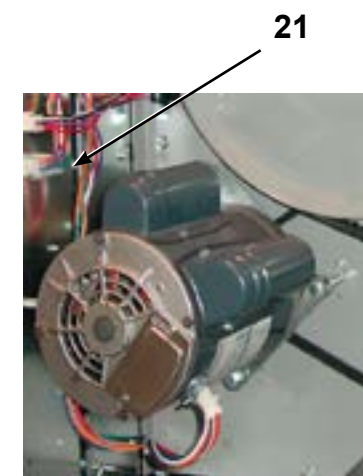
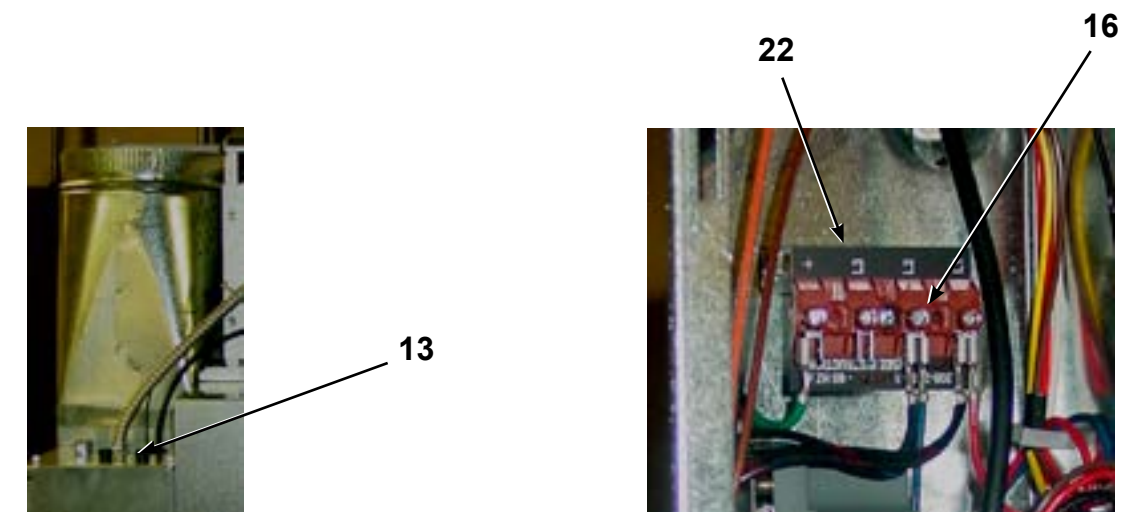
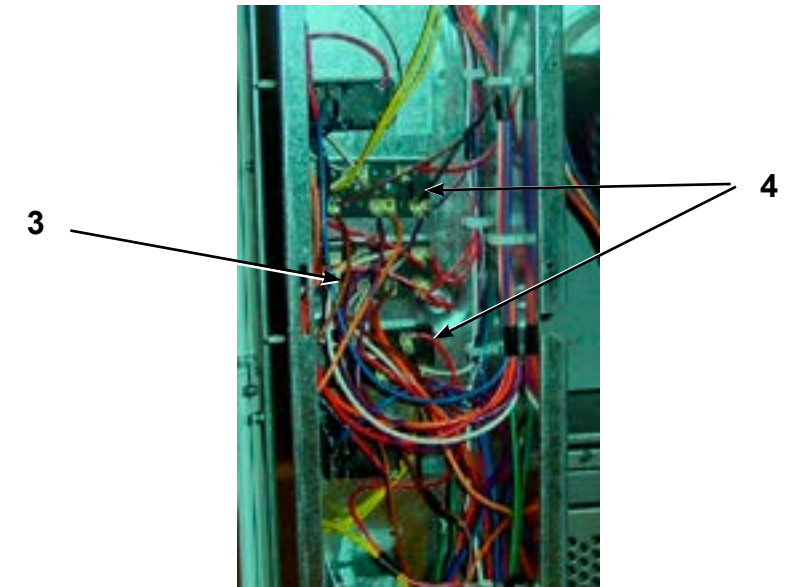

Kits, Assemblies, & Common Parts

DDBD50HC_-11

Loading Door Components	Part Number
Door Handle	9244-082-001
Door Close Switch	9539-487-001
Electrical Components	Part Number
Relay, Motor Run (24VAC)	5192-298-002
Transformer, Ignition/Control	8711-014-001
OPL Controls (Blue)	9857-187-001
OPL Controls (Black)	9857-187-003
Heating Circuit Components	Part Number
Ignition Control Module	9857-116-003
Ignition Electrode Assembly	9875-002-003
Thermostat, Hi-Limit	9576-203-002
Thermostat, Overtemp	9576-207-008
Fuseholder	9200-001-002
Fuse 1.5 amp	8636-018-001
Fuse 2.5amp	8636-018-004
Airflow Switch	9539-461-009
Cabinet Components	Part Number
Cleanout Duct Assembly 8"	9973-034-001



Section 7:

Parts Data
50# Stack

Cabinet Group - 50lb

Key	Part Number	Description	Quantity
*	9960-285-002	Door Assy., Loading Complete-Wht	2
*	9960-285-001	Door Assy., Loading Complete-SS	2
1	9960-284-002	Door Assy., Loading-SS(ring only)	2
2	9982-353-002	Plate Assy., Hinge (Wht) No Pin	2
2	9982-353-001	Plate Assy., Hinge (SS) No Pin	2
*	9545-012-015	Screw, Hinge to Door	8
*	8640-413-002	Nut, Hinge to Door	8
3	9212-002-004	Glass, Door	2
4	9206-164-010	Gasket, Glass (Gray).....	2
4	9206-413-002	Gasket, Glass (Black).....	2
*	9548-117-000	Support, Door Glass	2
5	9206-420-004	Gasket, Outer Rim (Gray)	2
5	9206-420-005	Gasket, Outer Rim (Black)	2
6	9244-082-001	Handle, Loading Door	2
*	9545-018-017	Screw, Handle 1/4-20 x 3/8	2
*	9531-033-001	Stud, Door Catch	2
*	8640-413-001	Nut, Hex	2
*	8640-413-003	Nut, Acorn	2
*	9086-015-002	Catch, Loading Door	2
*	8638-190-009	Pop Rivet for mtg. catch	4
*	8641-582-006	Lockwasher	4
*	8640-399-001	Spring Nut	6
7	9989-517-011	Panel Assy., Front- Lower (Wht)	1
7	9989-517-009	Panel Assy., Front- Lower (SS)	1
8	9989-517-015	Panel Assy., Front- Upper (Wht)	1
8	9989-517-013	Panel Assy., Front- Upper (SS)	1
*	9277-054-001	Insulation Front Panel, half moon (top).....	2
*	9277-054-002	Insulation Front Panel, half moon (bottom).....	2
*	9545-008-014	Screw, FLHDCR, 10B x 1.....	14
*	8641-582-019	Lockwasher	8
*	8640-399-001	Nut, Spring	12
10	9544-069-002	Strap, Hinge (Wht)	2
10	9544-069-004	Strap, Hinge (SS/Gray)	2
*	9545-012-028	Screw, Hinge to Panel	8
11	9545-052-001	Screw, Door to Hinge Strap (Special Black Type)	2
*	8641-436-003	Washer, Fiber	2
*	9472-001-013	Cabinet Touch Up Paint (White).....	1

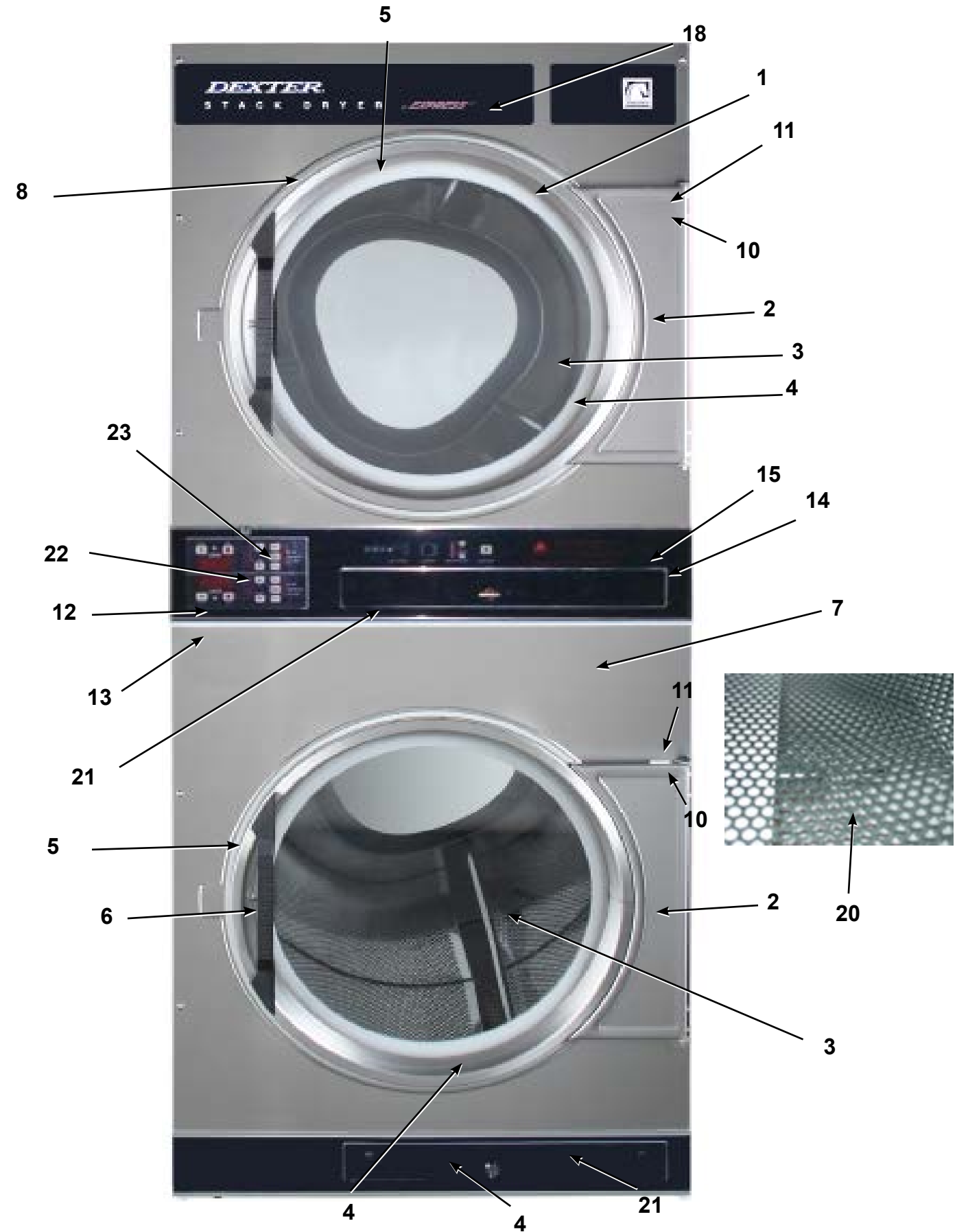

Cabinet Group - 50lb (Continued)

Key	Part Number	Description	Quantity
14	9994-032-002	Escutcheon, Upper	1
15	9435-025-001	Trim, Overlay-Upper (Blue)	1
15	9435-033-001	Trim, Overlay-Upper (Black)	1
16	9994-033-001	Escutcheon, Lower	1
17	9435-023-001	Trim, Overlay-Lower (Blue)	1
17	9435-031-001	Trim, Overlay-Lower (Black)	1
*	9545-020-009	Screw	10
18	9412-154-002	Nameplate Stack Dryer Express (Blue)1
18	9412-167-001	Nameplate Stack Dryer Express (Black)1
21	9866-005-002	Lint Drawer Assembly (Blue)	2
21	9866-005-005	Lint Drawer Assembly (Black)	2
21	9435-024-001	Overlay Trim, Lint Drwr (Blue)	1
21	9435-032-002	Overlay Trim, Lint Drwr (Black)	1
*	9532-074-003	Felt Seal (back of lint screen assembly)	2
*	9805-033-002	Lint Screen Assembly ONLY (no front)	2
*	9555-057-008	Replaceable Lint Screen Only	2
24	8650-026-002	Lock and Key, Lint Drawer Thumb Turn	2
*	9095-044-001	Cam, Lock	2
*	9545-008-001	Lint Screen Strap Hold Down Screws 10Bx 1/4	32
22	9857-187-001	Controls Assy, Electronic w/Membrane Switch (Blue)	1
22	9857-187-003	Controls Assy, Electronic w/Membrane Switch (Black)	1
22	9801-096-001	Membrane Switch Assy (Blue)	1
22	9801-105-001	Membrane Switch Assy (Black)	1
*	9627-885-001	Harness, Electronic Control	1
*	6292-006-007	Cam, Lock Control	1
*	9627-886-001	Harness, Heat Sensor	1
*	9277-041-017	Insulation Cabinet Cover	1
20	9501-004-004	Sensor Temp Control (10K Ohms)	2
*	9545-045-005	Screw, Round Head (Mounts sensor; phillips head)	2
*	9209-037-002	Gromm.et, 3/16 ID	2
*	8544-006-001	Leg, Leveling 1/2"	4
*	8545-061-002	Leveling Leg Wrench	1
*	9074-320-001	Cover, Cabinet (Top)	1
*	9732-253-001	DDAD Kit for Dryers without Neutral and using 208-240 volt...1	1
*	9732-102-013	LP Kit for DDAD Dryers 108K BTU	1
*	9732-243-001	Stack Dryer Trunion Puller	1
*	9555-057-010	Replaceable Lint Screen Fine Mesh Only	1
*	9277-054-001	Insulation-Front Panel-Top Half	2
*	9277-054-002	Insulation-Front Panel-Lower Half	2
*	9501-008-002	Bracket for Heat Sensor Mounting (Under Basket) with Sensor ..2	2
*	8640-276-002	Wire Nut Connector Grey	4
*	9527-007-002	Standoff Wire Saddle	8
*	9544-041-002	Strap - Bead Tie	1

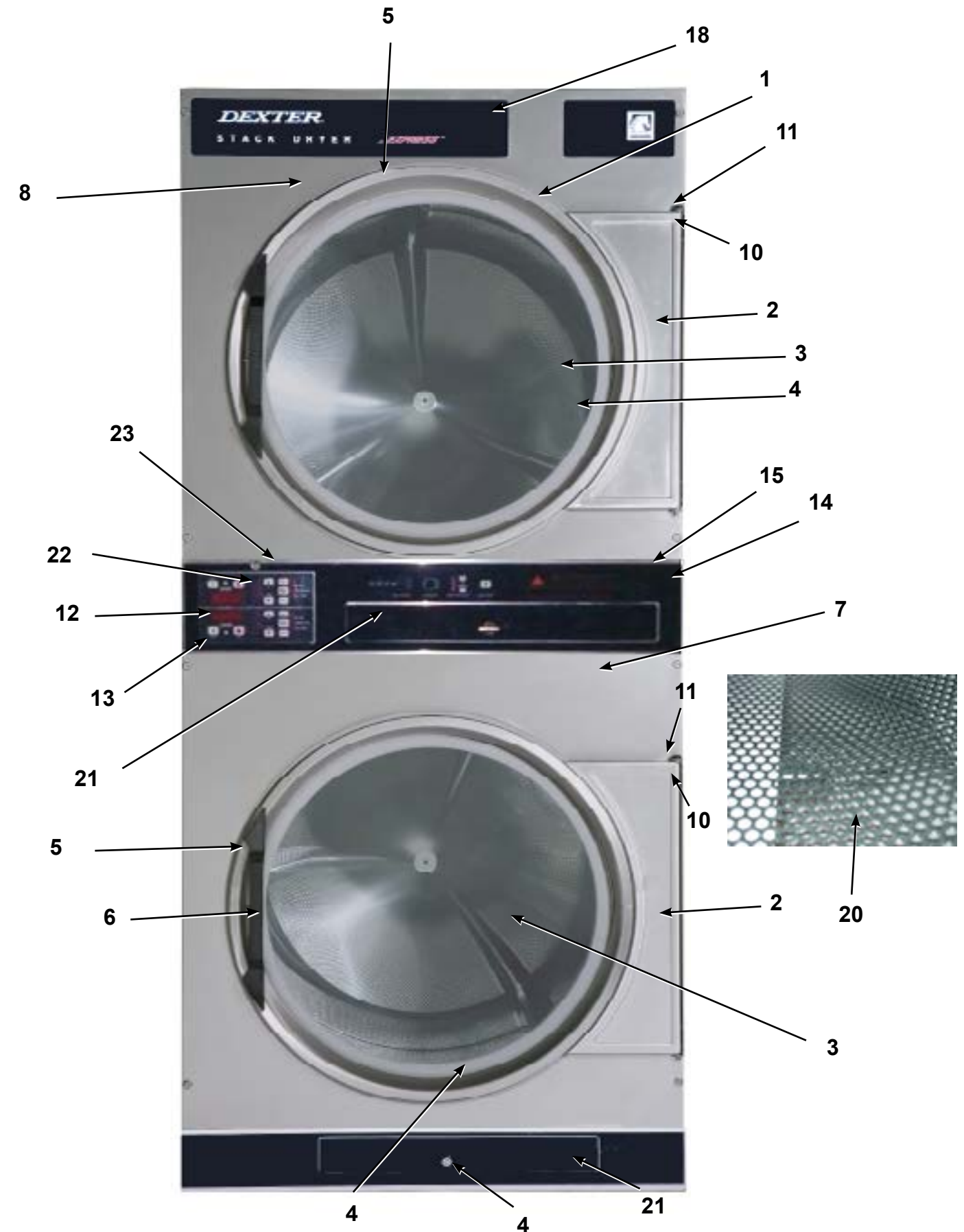

Tumbler Group

Key	Part Number	Description	Quantity
1	9848-148-001	Tumber Assembly Galvanized.....	2
1	9848-157-001	New Tumbler with Tall Baffles (Anti-Roping).....	2
*	9848-148-002	Tumbler Assembly Stainless Steel.....	2
*	9848-149-001	Tumbler Assembly Galvanized w/spider.....	2
*	9848-158-001	New Tumbler with Tall Baffles (Anit-Roping) w/Spider.....	2
*	9848-149-002	Tumbler Assembly Stainless w/spider.....	2
2	9568-013-001	Spider Assembly	2
3	9497-226-002	Rod, Tumbler	6
5	8640-417-005	Nut, 1/2 - 13	6
4	8641-590-002	Washer, Special	6
6	9552-013-000	Shim	AR

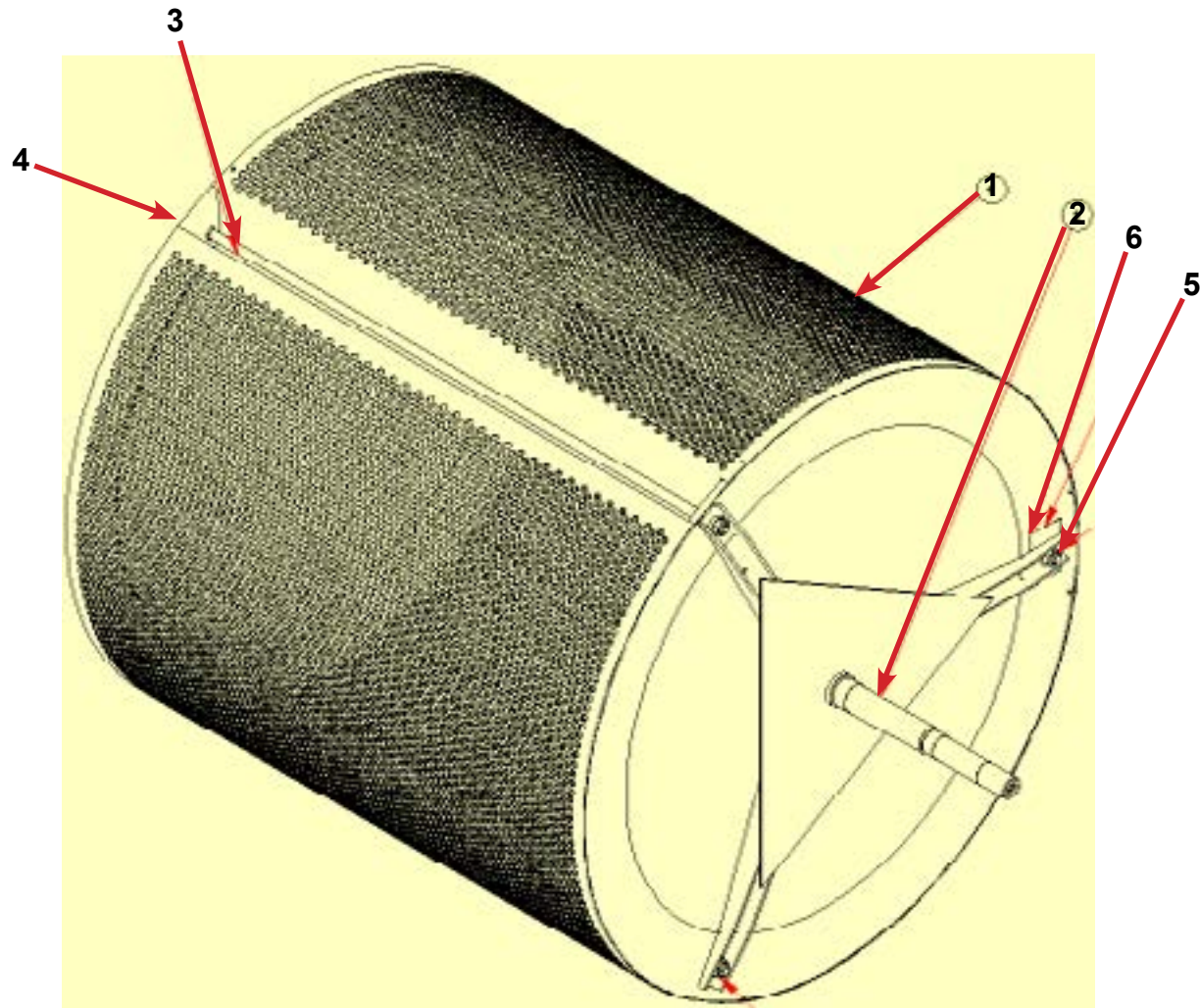

Bearing Housing Group - 50lb

Key	Part Number	Description	Quantity
J1	9241-189-002	Housing, Bearing	2
J2	9036-159-001	Bearing, Ball, Front	4
*	9036-159-003	Bearing, Ball, Rear.....	4
*	9538-183-001	Spacer, Bearing	2
J5	9545-017-017	Bolt, 1/2 x 3/4.....	8
J7	8640-417-002	Nut, 1/2	8
*	9803-201-001	Bearing Housing Complete Ass'y (includes bearings,spacer)	2
J4	9545-017-018	Screw 1/2 x 1 1/2	4
*	9036-159-003	Bearing Rear.....	1

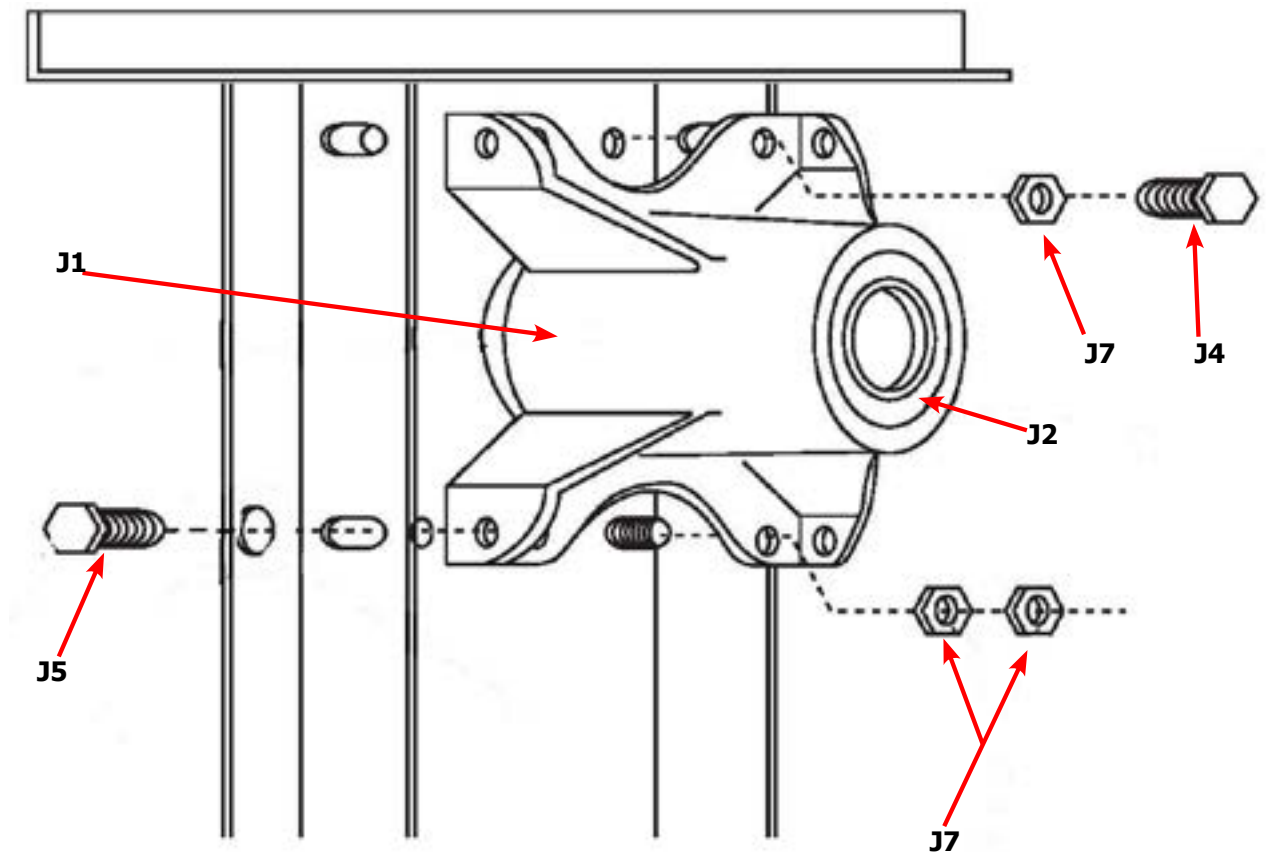

Burner Housing Group - 50lb

Key	Part Number	Description	Quantity
*	9803-207-001	Housing Assembly, Burner	2
1a	9452-730-001	Service Burner Plate Front.....	2
1	9452-729-001	Service Plate baffle Recirculation Chamber Clean Out	2
*	9545-008-006	Screws	8
2	9545-008-001	Screw	16
18	9003-220-001	Angle, Burner Support	2
*	9545-008-006	Screw	4
17	9048-020-002	Burner, Main	4
*	9545-008-006	Screw 10AB x 3/8"	4
*	9454-824-001	Panel, Back Burner Housing.....	2
4	9545-008-001	Screw 10B x1/4"	8
5	9875-002-003	Electrode Assy, Ignition	2
19	9545-045-001	Screw, Electrode Mtg 8B x 1/4".....	4
7	9379-186-001	Valve, Gas Shut Off	1
8	9857-134-001	Control Assy, Gas	2
9	9381-012-001	Manifold, Assembly 2 Part 1 Piece.....	2
*	9425-069-021	Orifice, Burner-Natural #29.....	4
*	9425-069-022	Orifice, Burner-LP #46.....	4
10, 14	9029-175-001	Bracket, Manifold	4
22	8615-104-038	Pipe Plug in end of Burner Manifold	2
*	9545-008-006	Screw	4
12	9576-203-002	Thermostat, Hi-Limit	2
*	9538-142-001	Spacer, Hi-Limit	4
*	9545-045-007	Screw 8B x 3/4".....	4
13	9074-329-001	Cover, Hi-Limit Stat Ignitor	2
*	9545-008-006	Screw	6
*	9576-207-008	Thermostat, Safety Shutoff	2
*	9545-008-006	Screw	4
15	9825-062-001	Cover, Safety Stat	2
*	9545-008-006	Screw	4
16	9857-116-003	Control, Ignition Fenwall (3 trybox)	2
*	9732-102-013	Kit, LP Conversion DDAD Kit	2
*	9838-018-003	Welded One Piece Gas Pipe Assembly	1

Burner Housing Group Photos - 50lb

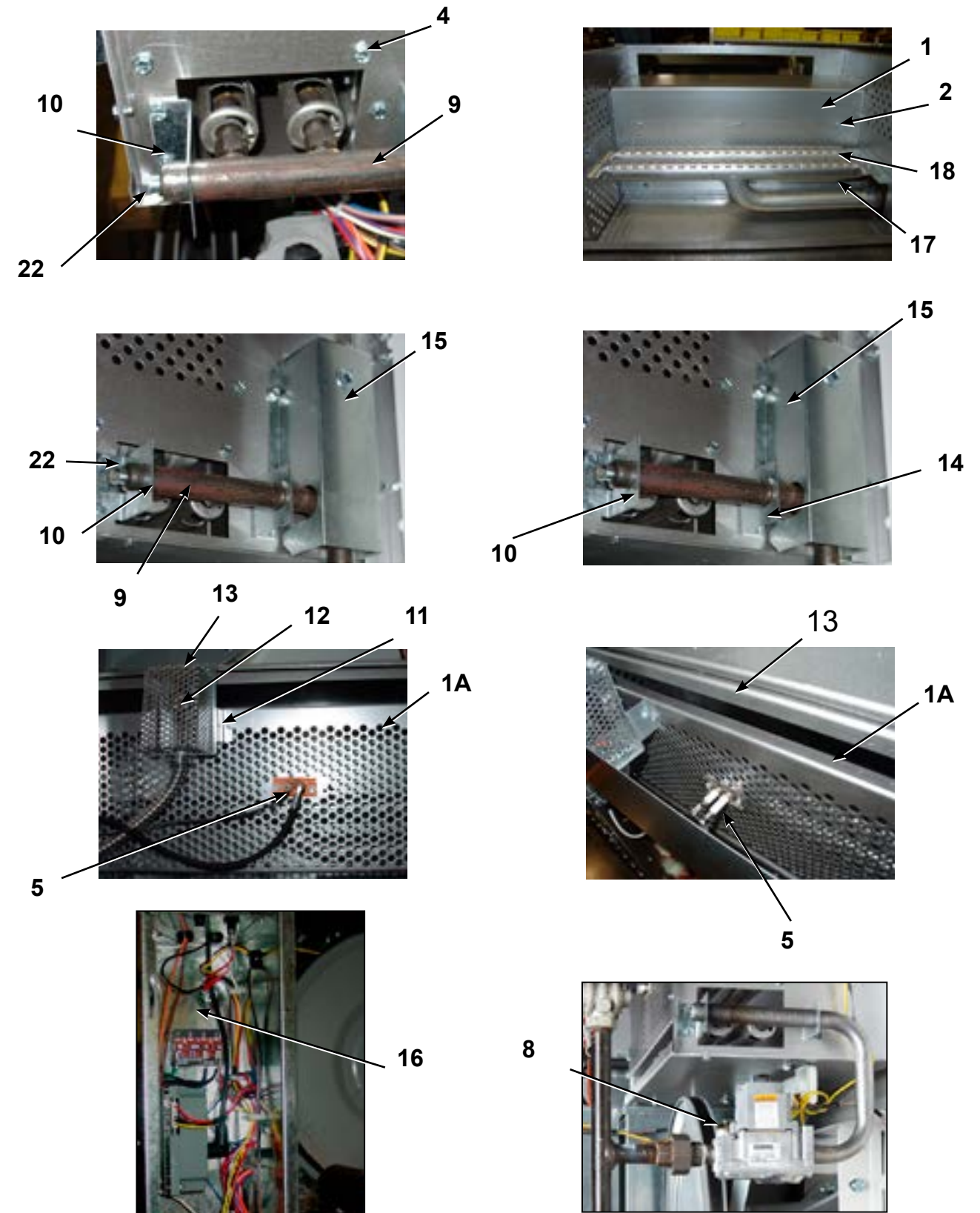

Rear View

Key	Part Number	Description	Quantity
*	9627-861-001	Wire Harness, Overtemperature Switch Upper	1
*	9801-098-001	Switch Assy, Air Flow	2
1	9539-461-009	Switch, Air Flow	2
2	9029-200-001	Bracket, Switch-Air Flow	2
*	8640-401-001	Nut, Special Twin #4-40	2
*	9550-169-003	Shield, Switch	2
3	9008-007-001	Actuator, Switch.....	2
4	9451-169-002	Pin, Cotter.....	2
5	9545-020-001	Screw, 4-40x 5/8	4
7	9376-322-001	Motor, Drive	2
*	9732-205-027	Motor Kit.....	
*	5191-108-002	Capacitor, Motor Run.....	1
*	5191-109-002	Capacitor, Motor Start	1
27	9453-169-013	Motor-Pulley, Driver.....	2
*	9452-770-001	Plate, Motor Mounting	2
9	9962-018-002	Plate, Impeller Mounting.....	2
*	9538-163-006	Spacer, Motor Mounting	8
*	9545-029-008	Screws, Hex Cap.....	8
*	8641-582-003	Lock Washers	8
*	9545-018-019	Screw HXHD 1/4-20 x 2 1/2	8
*	8641-581-017	Washer-Flat, 1/4 x 7/8	32
*	9538-166-006	Spacer, Metal.....	8
12	9991-053-001	Support Assy, Intermediate pulley.....	2
12	9545-029-010	Bolt, Rd Hd 3/8-16 x 1 1/4	6
12	8640-415-004	Nut Flange Wizlock 3/8 - 16	6
12	8641-581-035	Washer, Flat	6
13	9545-029-003	Bolt, 3/8 - 16 x 1 1/2.....	2
14	9861-022-001	Arm Assy-Tension, Complete.....	2
*	9487-200-003	Ring-Retaining.....	6
16	9908-048-003	Pulley Assy, Intermediate w/Bronze Flange Bearing	2
*	9036-145-002	Bearing - Bronze Flange	4
17	9908-047-002	Pulley Driven, Tumbler.....	2
*	9487-234-005	Tolerance Ring.....	2
34	8641-581-026	Washer, Flat 1/2" for Tumbler Pulley.....	2
35	9545-017-009	Bolt, 1/2" - 13 x 1 1/4	2
36	8641-582-016	Washer, Star 1/2" for Tumbler Pulley	2
*	9538-184-001	Spacer, Shaft.....	2
19	9040-076-009	Belt, Drive Motor and intermediate.....	2
20	9040-073-011	Belt, Driven-intermediate to.....	2
21	9534-151-000	Spring, Tension.....	2
22	9099-012-005	Chain Tension.....	2
23	9248-022-002	Hook, Tension	2
*	9451-146-001	Pin, Damper Hinge.....	2
*	8520-141-000	Nut, Spring.....	4
*	9825-334-001	Cover, Duct-Upper	1
25	9973-032-001	Heat Recirculation Assembly Duct	2
*	9545-028-013	Set Screw.....	2
30	9278-043-001	Impeller	2
*	9125-007-001	Damper, Exhaust Duct - Upper	1
*	9125-007-002	Damper, Exhaust Duct - Lower	1
*	8520-141-000	Nut, Spring.....	4
*	9545-008-026	Screw #10B x 1/2	14
*	9074-335-001	Cover, Duct - Lower	1
*	9545-008-024	Screw #10AB x 3/8	58
*	9029-173-001	Bracket for Wire Harness Under Burner Housing	2

Rear View Photos - 50lb

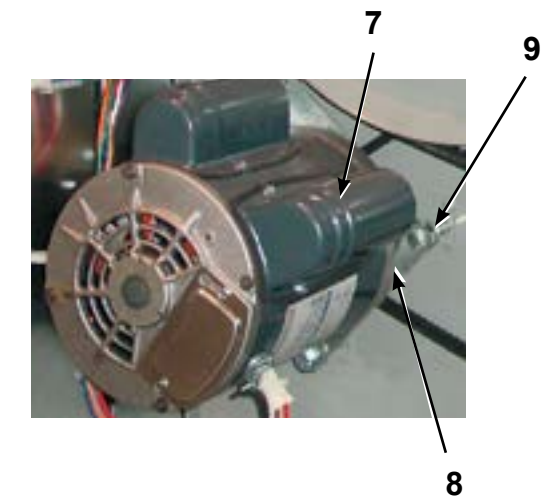
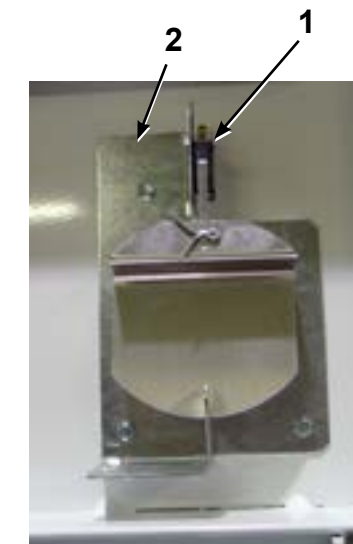
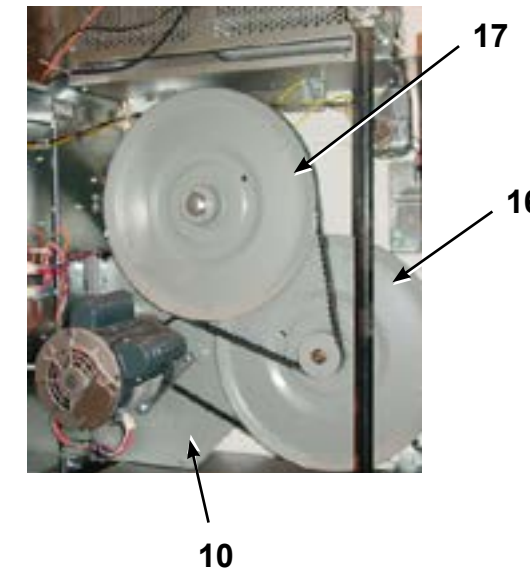
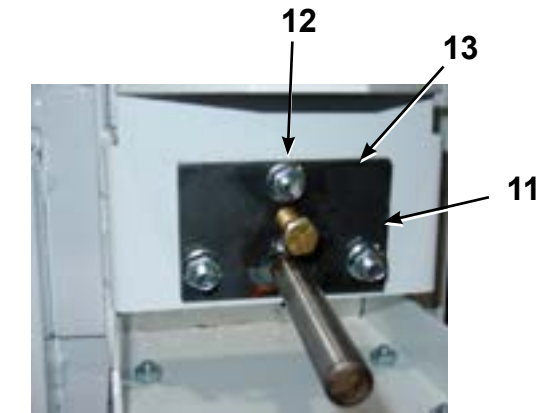

Rear Panel & Cover Group - 50lb

Key	Part Number	Description	Quantity
1	9208-090-001	Rear Guard Side Panel 1	2
4	9545-008-024	Screws 10 AB x 3/8	30
*	9208-089-001	Rear Guard Top, Lower	1
7	9545-082-024	Screws 10 AB x 3/8	6
8	9208-089-001	Rear Guard Back Panel	2
10	8502-600-001	Label Warning & Notice	1
11	8502-645-001	Label - Instructions	1
12	9109-113-001	Transition Assembly Outlet	1
13	9074-320-001	Top Cover Dryer Panel	1
14	9550-188-001	Top Burner Housing Heat Shield	1
*	9973-034-001	8" Slide Open Clean Out Duct (Optional)	1

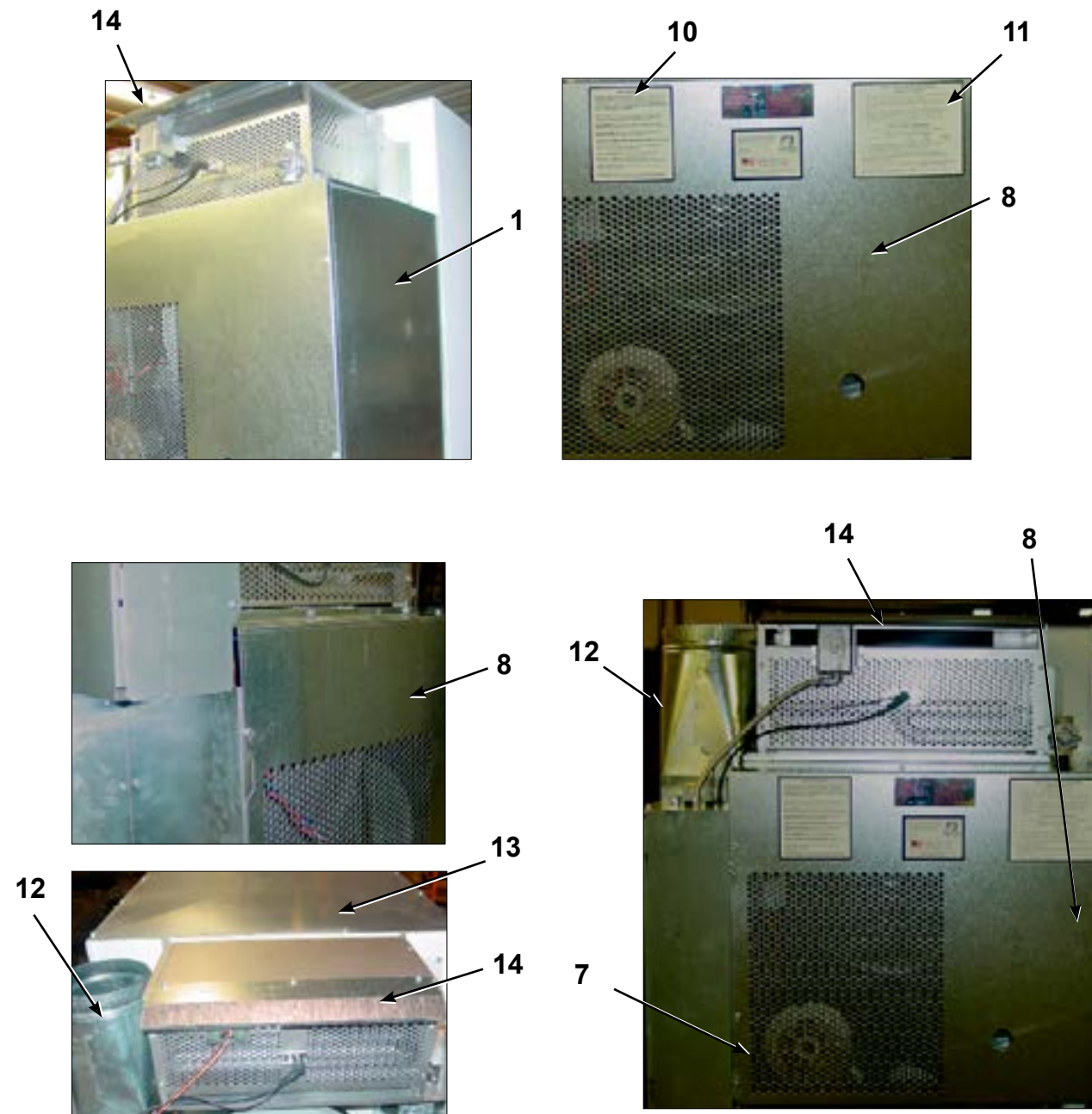

OPL Control Board

Key	Part Number	Description	Quantity
1	9857-187-001	Control Assembly (Blue)	1
1	9857-187-003	Control Assembly (Black)	1
2	9471-017-001	PCB Control Board	1
3	9471-018-001	PCB Display Board	1
4	9500-007-001	Cable, Upper Control Long	1
5	9500-007-002	Cable, Lower Control Long	1
6	9801-096-001	Membrane Switch Assembly (Blue)	1
6	9412-167-001	Membrane Switch Assembly (Black)	1
7	8636-024-001	Fuse, 600ma / 250v	2
*	9627-885-001	Harness Main Control OPL Stack Dryer	1

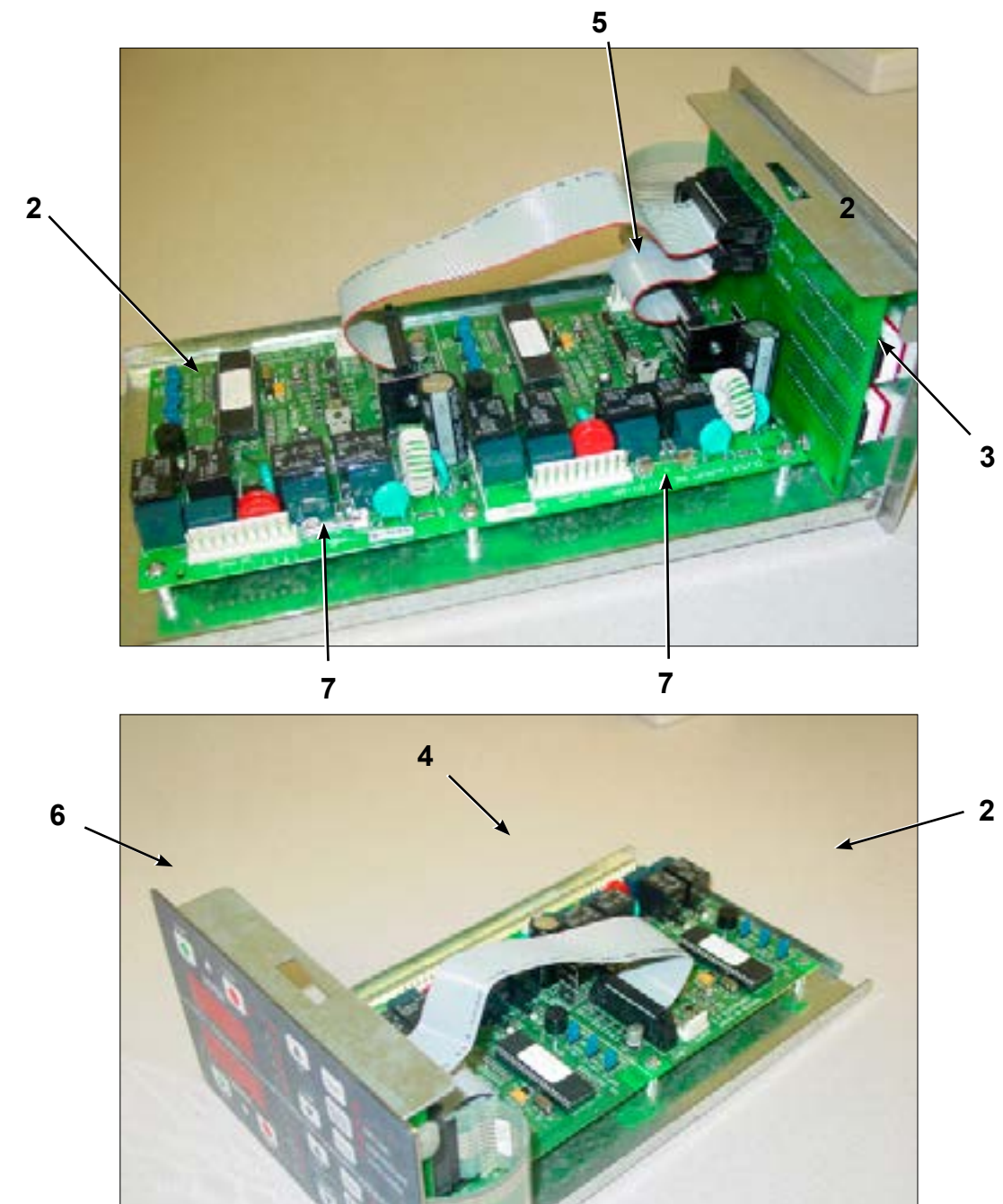

Control Assembly Group - 50lb

Key	Part Number	Description	Quantity
*	9857-189-002	Control Assmly Complete (all below included)	1
*	9108-117-001	Control Box Door	1
*	8220-001-478	Wire Assembly Green 7"	1
*	8639-621-007	Screw #10-32 x 12 Green	1
*	8641-582-006	Lockwasher Ext Tooth #10	1
3	9897-026-002	Terminal Block Main Power Middle	1
4	9897-026-001	Terminal Block	2
*	9545-045-012	Screw #8 ABx 1/2 for terminal block	6
5	8711-014-001	Transformer Ignition	1
*	9545-008-024	Screws 10AB x 3/8"	4
6	9982-348-001	Plate Assembly MTG Ignition Control	2
*	9545-008-001	Screws 10B x 1/4" MTG Above Plate and Others	14
7	9857-116-003	Ignition Control	2
*	8640-411-003	#6-32 Nuts	4
8	9631-403-009	Wire Assembly High Voltage Upper	2
9	9627-860-001	Wire Harness Ignition Control Upper	1
10	9627-860-002	Wire Harness Ignition Control Lower	1
*	9053-067-002	Bushing Wire 7/8"	6
13	9200-001-002	Fuseholder Assembly	2
14	8636-018-001	Fuse 1.5 Amp	2
15	5192-298-002	Relay Power 24 VAC	2
16	9897-035-001	Terminal Block Assembly Main Power Inlet	1
*	9545-045-012	Screw #8 AB x 1/2"	4
*	8220-062-036	Wire Assembly Red/Black 14"	1
*	8220-062-037	Wire Assembly Red/White 14"	1
*	8220-062-038	Wire Assembly White 14"	2
*	9627-859-001	Wire Harness - Power Main Input	1
21	9627-864-001	Wire Harness Motor Extension	2
*	9527-007-001	Stand Off - Wire Saddle / Arrowhead	15
*	9545-031-005	Screw 6 B x 3/8"	4
22	9558-029-003	Strip Terminal Marker (Behind Input Power) to above #3	1
*	9627-887-001	Wire Harness Main Extension Access Under Burner Housing	1
23	9631-403-008	Wire Ass'y - High Voltage Lower	1
24	9029-048-001	Bracket - Fuseholder	2
*	8220-095-011	Wire Assembly - Red, 37"	1
*	8220-095-012	Wire Assembly - Blue, 42"	1
*	8220-095-013	Wire Assembly - White, 43 1/2"	1
*	8220-062-028	Wire Assembly - Black, 17"	1
*	8653-039-000	Connector Wire, 1/4"	1

Control Assembly Group - 50lb

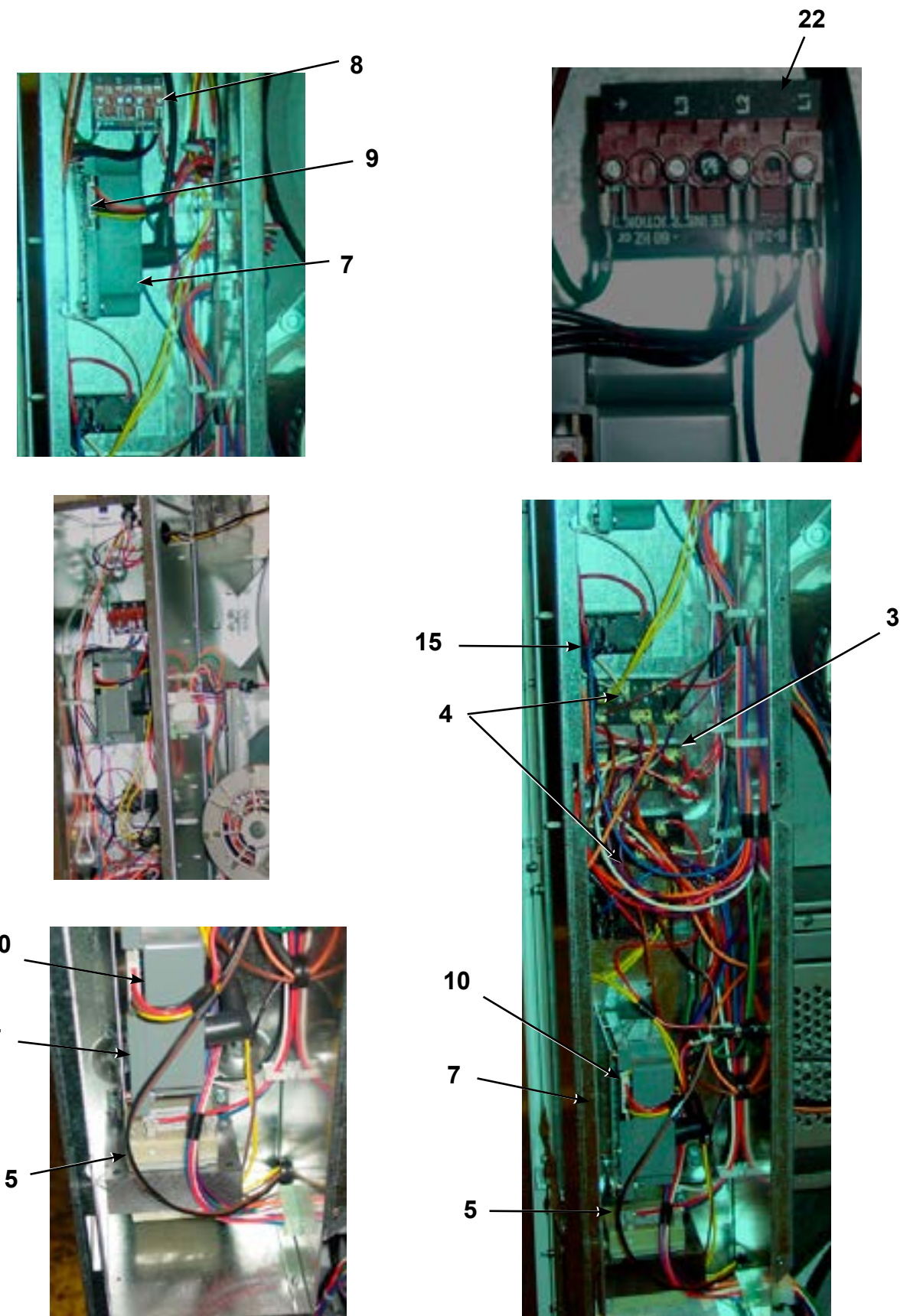

Door Switch Group

Part Number
9539-487-001

Description
Door Switches 2

Quantity
2



Section 8: Electric Heated 60Hz

Electric Heated Parts DDAD30HC_-16FC

Key	Part Number	Description	Quantity
*	8220-001-499	Wire-BLK, 26"	2
*	8220-057-016	Wire-BLK, 8", 8 AWG.....	6
*	8220-057-021	Wire-WHT, 5 1/2", 18 AWG.....	2
*	8220-057-023	Wire-BLK, 9 1/2", 10 AWG.....	12
*	8220-057-031	Wire-BLK, 36", 12 AWG.....	1
*	8220-057-032	Wire-RED, 36", 12 AWG.....	1
*	8220-061-011	Wire-BLK, 17", 10 AWG	12
*	8220-063-020	Wire-WHT/BLK, 65" 18 AWG.....	1
*	8220-078-014	Wire-BLK, 22" 18 AWG.....	2
*	8220-095-023	Wire-BRN, 54" 18 AWG.....	2
*	8220-103-002	Wire-Red, 19" 18AWG.....	2
*	9636-155-001	Wrapper-Housing, Heater.....	2
*	9545-008-001	Screw 10B x 1/4.....	6
*	9551-032-001	Side-Housing, Heater, Right Hand.....	2
*	9551-033-001	Side-Housing, Heater, Left Hand.....	2
*	9551-040-001	Side Control Heater.....	4
*	9114-044-001	Defl ector-Bottom Housing.....	2
*	9545-008-024	Screw-10AB x 3/8.....	6
*	9058-026-001	Bottom-Housing, Heater.....	2
*	9545-008-024	Screw-10AB x 3/8.....	22
*	9114-045-001	Defl ector-Wraper, Housing.....	2
*	9545-008-024	Screw-10AB x 3/8.....	8
*	9114-046-001	Defl ector-Baffl e.....	12
*	9049-078-001	Baffl e-Housing, Heater.....	2
*	9636-191-001	Wrapper-Control, Heater.....	2
*	9074-293-001	Cover-Plate, Heater.....	2
*	9551-040-001	Side-Control Heater.....	4
*	9545-008-024	Screw-10AB x 3/8.....	16
*	9029-194-001	Bracket-Control, Heater.....	4
*	9074-333-001	Cover-Control, Heater.....	2
*	9545-018-014	Screw-1/4-20 x 3/4.....	8
*	9277-041-014	Insulation.....	2
*	9029-181-001	Bracket-Back, Panel.....	1
*	9074-337-001	Cover-Terminal, Heater.....	2
*	9576-207-006	Thermostat-Overtemp, Manual reset.....	2
*	9538-166-005	Spacer Over Temp Thermostat.....	4
*	9982-364-001	Plate Assembly-Overtemp switch.....	2
*	9627-861-002	Harness-Over Temp Switch.....	2
*	9348-066-001	Lever-Overtemp Switch.....	2
*	9452-769-001	Plate-Over Temp Switch.....	2
*	9497-229-001	Rod-Over Temp Switch.....	2
*	9488-011-002	Rail-Din, 35 x 15mm.....	2

DDAD30HC_-16FC 208/60/3 24KW

Key	Part Number	Description	Quantity
*	5192-285-004	Relay.....	2
*	5192-296-001	Relay, Heating Element.....	2
*	9377-003-001	Varister-Coil Supressor.....	2
*	5198-213-002	Circuit Breaker-3 Pole.....	4
*	8652-134-002	Terminal-Lug, Solderless.....	4
*	9870-093-004	Heater Element, 12KW 208V.....	6
*	9295-004-002	Jumper-Formed.....	4
*	9295-005-002	Jumper-Straight.....	8
*	9897-037-001	Block-Power, 3 Pole.....	2
*	9897-038-001	Block-Power, 1 Pole.....	2
*	9506-466-001	Wiring-Schematic.....	1
*	9506-467-001	Wiring-Diagram.....	1
*	9506-468-001	Wiring-Diagram/Schematic.....	1
*	8514-202-001	Booklet-Owners, DDAD30HC_-16FC.....	1

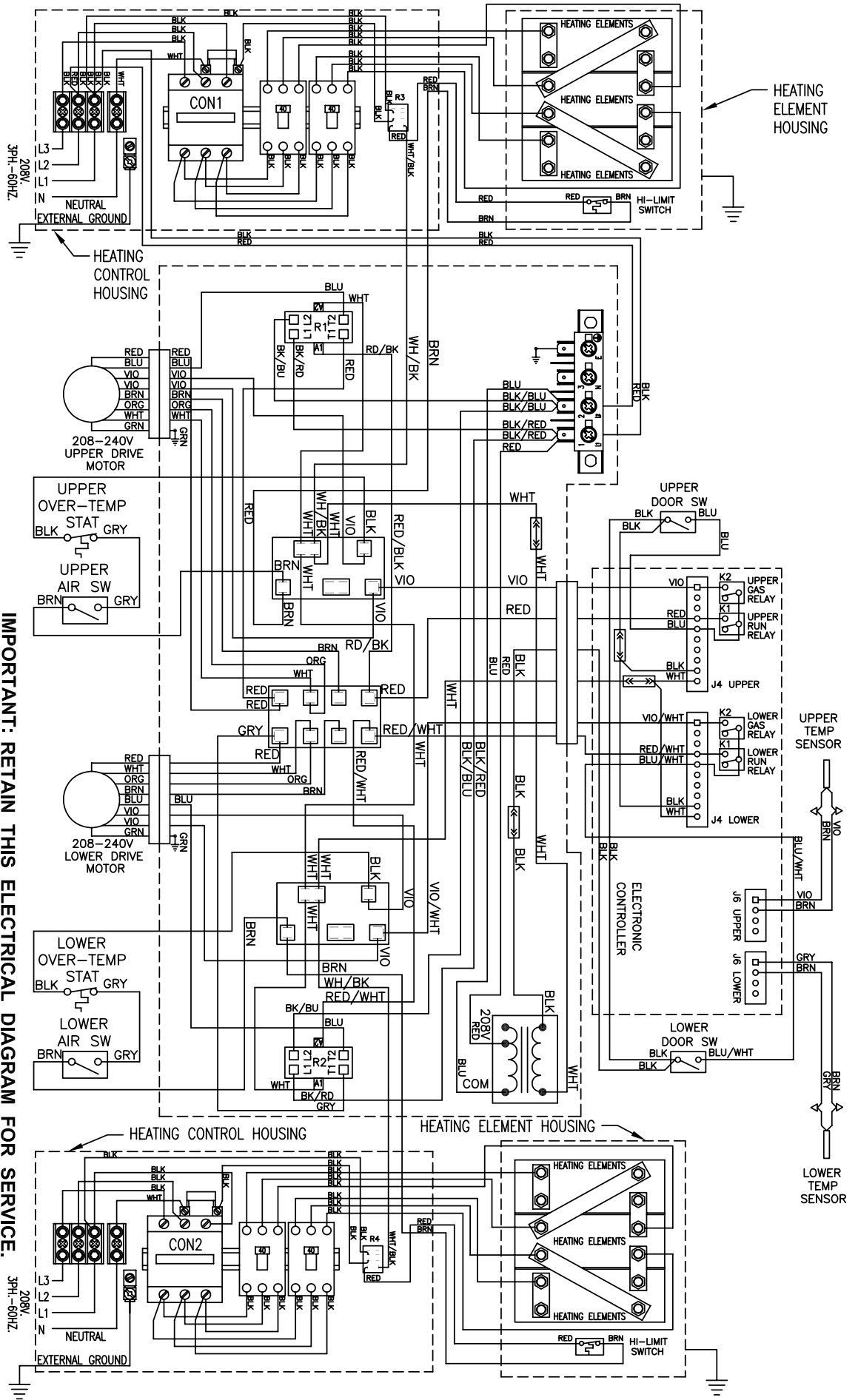

IMPORTANT: RETAIN THIS ELECTRICAL DIAGRAM FOR SERVICE.

9506-467-002A

WIRING DIAGRAM

DDAD30HC-16FC

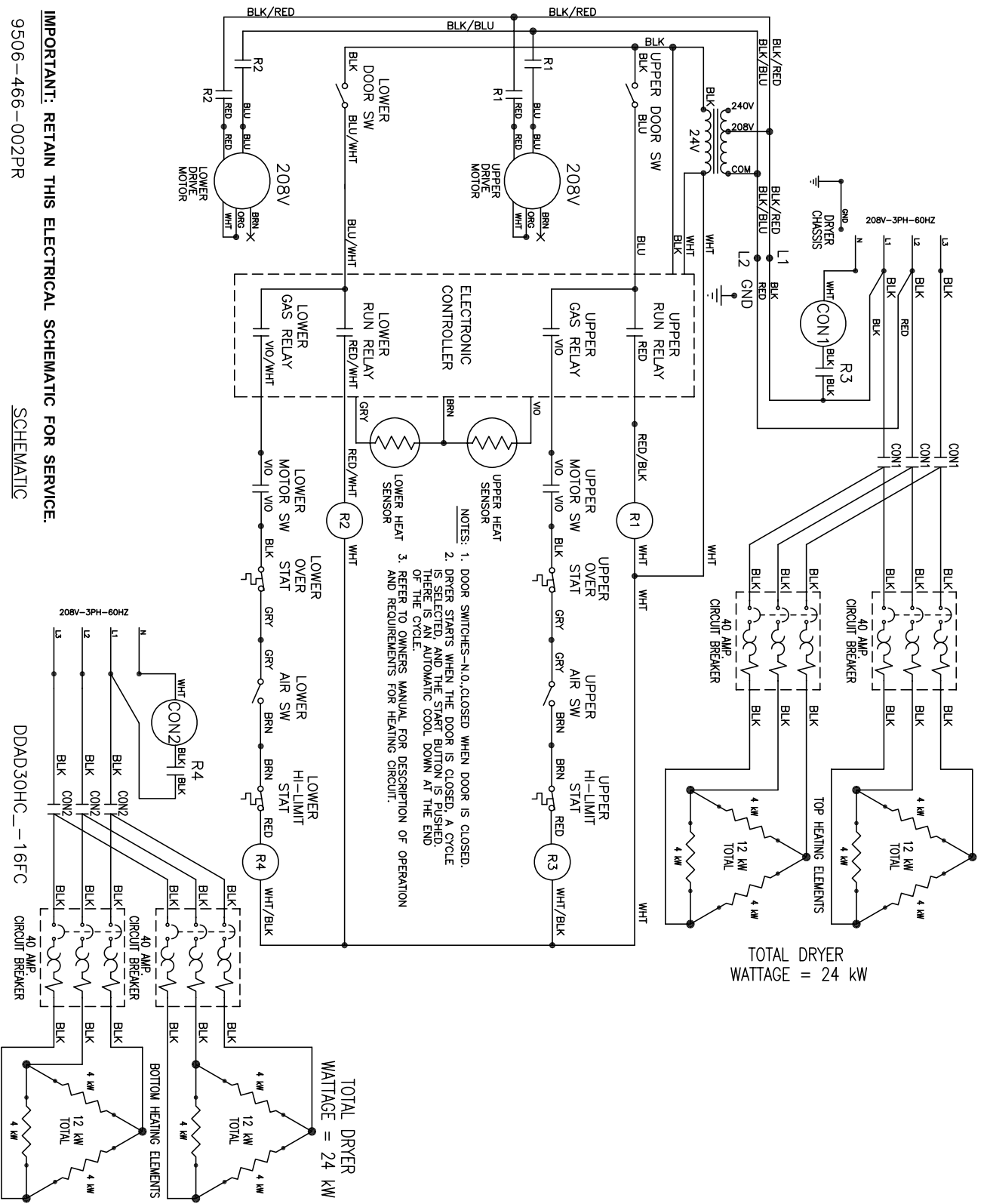

IMPORTANT: RETAIN THIS ELECTRICAL SCHEMATIC FOR SERVICE.

9506-466-002PR

SCHEMATIC

DDAD30HC-16FC

50 Hz Specifications

Dry Weight Capacity:	13.5kg @ 2 each - 27kg total
Basket Depth:	699mm
Basket Diameter:	762mm
Basket Volume:	318 liters
Door Opening:	576mm
Overall Height (with legs):	min. 1937mm, max.
Cabinet Width:	800mm
Overall Depth:	1270mm
Door Height (floor to bottom of door):	186mm
Cylinder Rotation Direction:	CCW
Speed:	47rpm
Natural Gas Supply (water column):	4" - 10" wc
Natural Gas at Burner Manifold:	3 1/2" wc
LP Supply:	11" - 14" wc
LP Burner:	11" wc
Gas Inlet Line Size:	1/2" npt
Motor Size:	373kw

Electrical

Voltage: 220-240v/ 50hz/ 1 phase	
Running Amps:	10.0
Amp Circuit Protection:	15
Wire Size:	12 guage
Electrical Service:	3 wire + ground

Weights

Shipping:	351kg
Net Weight:	311kg

Clearance behind machine for service minimums:	457mm
--	-------

Heat Circuit

Top Dryer Used For This Example

With the Drive Motor running and 24 VAC provided to the Computer Board Gas Relay, it will close if Computer Board senses programmed temperature is needed. The violet wire changes to an orange wire out of the Computer Board Gas Relay. When this relay closes it provides 24 VAC to the High Limit Thermostat. The High Limit Thermostat is normally closed. (It will open, turning off the heat circuit, if the dryer can't move enough air from problems such as an exhaust restriction or other problems.) 24 VAC now goes through to the normally open Air Switch (Sail Switch) on the brown wire. This switch is closed only if the dryer is running and has the correct air flow. With the dryer running and the Air Switch closed, 24 VAC is supplied to the normally closed upper manual reset Over-temp Thermostat on the gray wire and changes to the black wire out of switch and then changes to red wire and goes to the 1.5 amp in-line fuse that protects the Upper Ignition Controller(GREY BOX). With 24 VAC now supplied to the Upper Ignition Controller (GREY BOX) it will then send high voltage to the Spark Ignition Electrode via the High Voltage Lead Wire (this lead looks like an automotive spark plug wire). The Ignition Control Module (GREY BOX)simultaneously sends 24VAC to the Gas Valve Coil which open the Gas Valve and allows gas to pass through to the main burner. When ignition occurs the high voltage sparking stops and if Ignition Control Module (GREY BOX) gets a flame sense signal it will allow gas valve coil to remain energized and continue burner operation. If ignition does not occur, the Ignition Control Module (GREY BOX) will spark for 10 seconds before locking out.

Control Assembly Group - 30lb

Key	Part Number	Description	Quantity
*	9857-169-006	Control Assmby Complete (all below included).....	1
*	9108-117-001	Control Box Door.....	1
*	8220-137-002	Wire Assembly Green 7".....	1
*	8639-621-007	Screw #10-32 x 12 Green.....	1
*	8641-582-006	Lockwasher Ext Tooth #10.....	1
*	9897-026-002	Terminal Block Main Power Middle.....	1
*	9897-026-001	Terminal Block.....	2
*	9545-045-012	Screw #8 ABx 1/2 for terminal block.....	6
*	8711-008-002	Transformer Ignition.....	1
*	9545-008-024	Screws 10AB x 3/8".....	4
*	9982-348-001	Plate Assembly MTG Ignition Control.....	2
*	9545-008-001	Screws 10B x 1/4" MTG Above Plate and Others.....	14
*	9857-140-001	Ignition Control.....	2
*	8640-411-003	#6-32 Nuts.....	4
*	9631-403-009	Wire Assembly High Voltage Upper.....	2
*	9627-867-001	Wire Harness Ignition Control Upper.....	1
*	9627-867-002	Wire Harness Ignition Control Lower.....	1
*	9053-067-002	Bushing Wire 7/8".....	6
*	9200-001-002	Fuseholder Assembly.....	2
*	8636-018-001	Fuse 1.5 Amp.....	2
*	5192-295-013	Relay Power 24 VAC.....	2
*	9897-035-001	Terminal Block Assembly Main Power Inlet.....	1
*	9558-029-004	Strip Terminal Marker (Behind Input Power).....	1
*	9545-045-012	Screw #8 AB x 1/2".....	4
*	8220-062-036	Wire Assembly Red/Black 14".....	1
*	8220-062-037	Wire Assembly Red/White 14".....	1
*	8220-062-038	Wire Assembly White 14".....	2
*	9627-859-001	Wire Harness - Power Main Input.....	1
*	9627-864-002	Wire Harness Motor Extension.....	2
*	9527-007-001	Stand Off - Wire Saddle / Arrowhead.....	15
*	9545-031-005	Screw 6 B x 3/8".....	4
*	9627-861-001	Wire Harness Main Extension Access Under Burner Housing.....	1
*	9631-403-008	Wire Ass'y - High Voltage Lower.....	1
*	9029-048-001	Bracket - Fuseholder.....	2
*	8220-095-011	Wire Assembly - Red, 37".....	1
*	8220-095-012	Wire Assembly - Blue, 42".....	1
*	8220-095-013	Wire Assembly - White, 43 1/2".....	1
*	8220-062-028	Wire Assembly - Black, 17".....	1
*	8653-039-000	Connector Wire, 1/4".....	1

DDAD30HC_-59_ Gas Control Parts

Key	Part Number	Description	Quantity
3	9732-162-001	Kit-Honeywell VR86 Valve Flange.....	4
*	9791-001-001	Adapter Assembly - Gas Inlit.....	1
2	9857-132-004	Gas Control Valve.....	2
*	9425-069-009	Orifice - Mainburner, #32.....	4

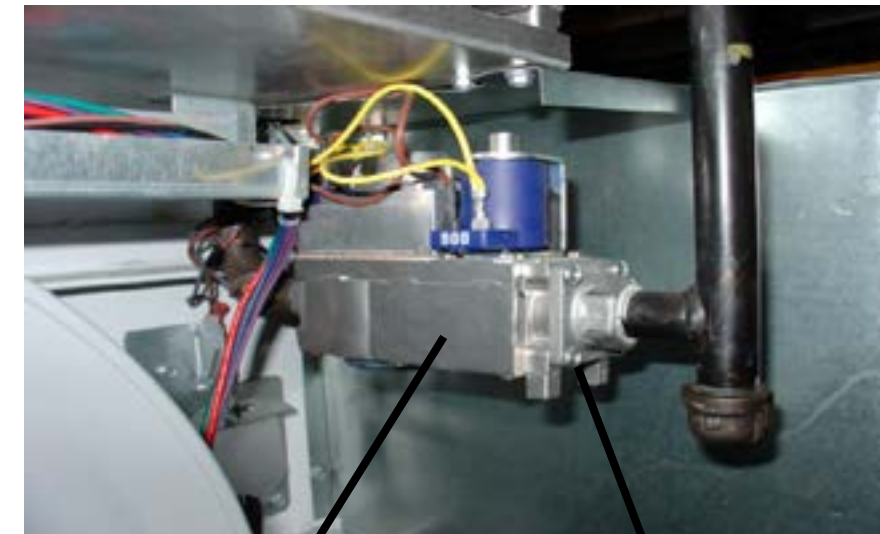

2

3



13



12

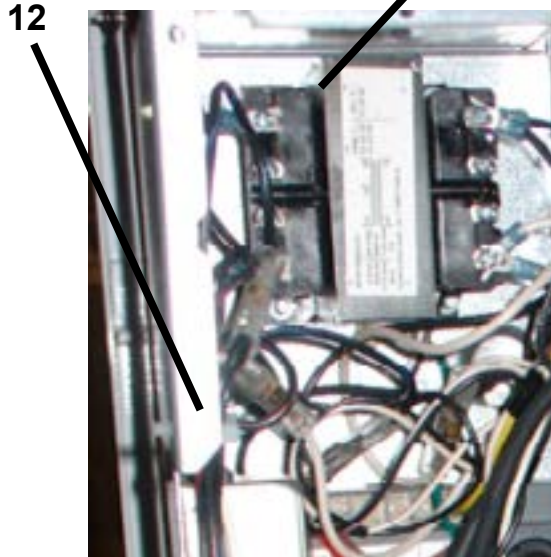

12

7



7

Electrical Components 50Hz Gas Heated DDAD30HC_-59

Key	Part Number	Description	Qty
*	5192-295-013	Relay	2
*	8220-062-008	Wire assy-BLK, 11".....	1
*	8220-062-034	Wire assy-WHT, 11"	1
*	8220-065-006	Wire assy-BLK/RED, 11".....	1
*	8220-065-022	Wire assy-BLK/BLU, 19"	1
*	8220-065-033	Wire assy-WHT, 11"	1
*	8220-065-040	Wire assy-BLK, 40"	1
*	8640-276-006	Nut-Wire Connection, #72B, BLU	4
7	8711-008-002	Transformer Control	1
12	9183-030-002	Filter-line, EMI	1
13	9379-296-004	Motor-Dryer, A.O. Smith 50Hz.....	2
13	9376-318-001	Motor-Dryer, Marathon 50Hz.....	2
*	9453-169-009	Pulley-Motor	2
*	9627-864-002	Wiring Harness-Motor Extention	2
*	9627-866-001	Wiring Harness-Motor Main	2
*	9627-867-001	Wiring Harness-Ignition Control, Upper	1
*	9627-867-002	Wiring Harness-Ignition Control, Lower	1
8	9857-140-001	Ignition Module, Fenwal	2
*	8502-743-001	Label-Warning, Lifting Hazard	1
*	8507-230-003	Instructions-Transformer Connect	2
*	8514-201-001	Booklet-Owners DDAD30HC_-59	1
*	9506-456-001	Wiring-Schematic	1
*	9506-457-001	Wiring-Diagram	1
*	9506-458-001	Wiring-Schematic/Diagram	1

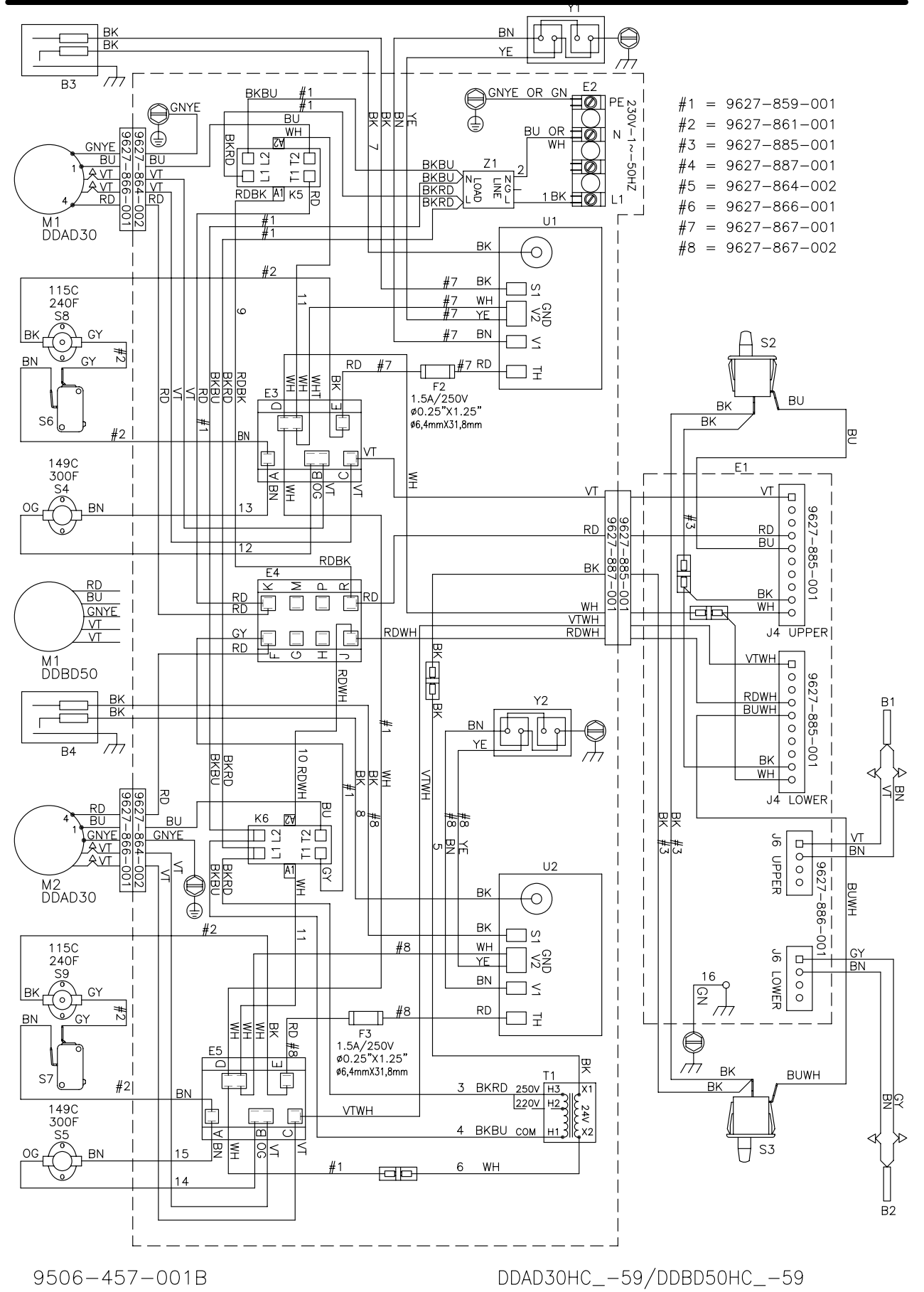
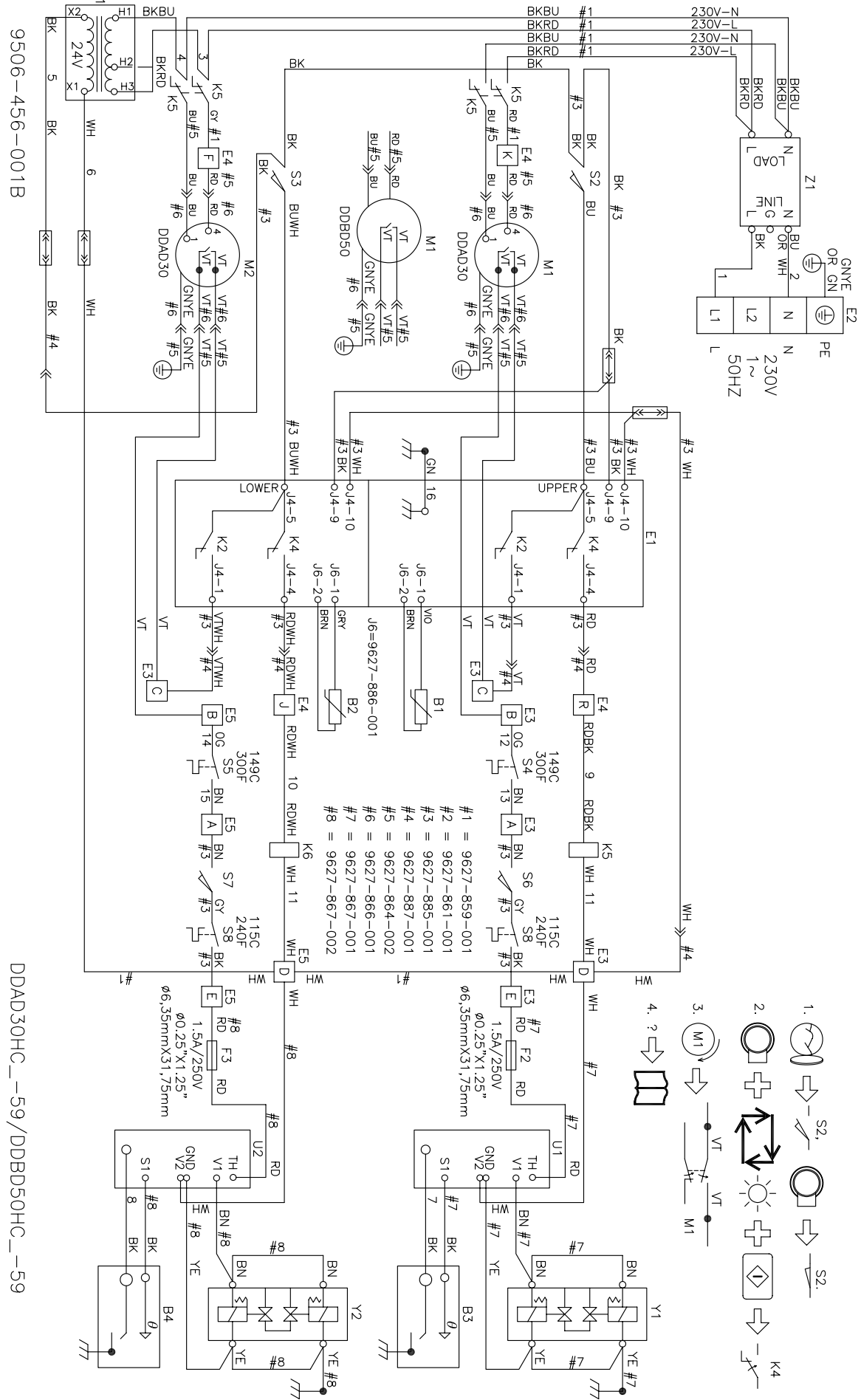

Electric Heated Parts DDAD30HC_-64FN

Key	Part Number	Discription	Qty
	8220-001-499	Wire-BLK, 26"	2
	8220-057-016	Wire-BLK, 8", 8 AWG.....	6
	8220-057-021	Wire-WHT, 5 1/2", 18 AWG.....	2
	8220-057-023	Wire-BLK, 9 1/2", 10 AWG.....	12
	8220-060-003	Wire-BLK, 5".....	1
	8220-061-011	Wire-BLK, 17", 10 AWG	12
	8220-063-020	Wire-WHT/BLK, 65" 18 AWG.....	1
	8220-078-014	Wire-BLK, 22" 18 AWG.....	2
	8220-095-023	Wire-BRN, 54" 18 AWG.....	2
	8220-103-002	Wire-Red, 19" 18AWG.....	2
	9636-155-001	Wrapper-Housing, Heater.....	2
	9545-008-001	Screw 10B x 1/4.....	6
	9551-032-001	Side-Housing, Heater, Right Hand.....	2
	9551-033-001	Side-Housing, Heater, Left Hand.....	2
	9551-040-001	Side Control Heater.....	4
	9114-044-001	Deflector-Bottom Housing.....	2
	9545-008-024	Screw-10AB x 3/8.....	6
	9058-026-001	Bottom-Housing, Heater.....	2
	9545-008-024	Screw-10AB x 3/8.....	22
	9114-045-001	Deflector-Wraper, Housing.....	2
	9545-008-024	Screw-10AB x 3/8.....	8
	9114-046-001	Deflector-Baffle.....	12
	9049-078-001	Baffle-Housing, Heater.....	2
	9636-191-001	Wrapper-Control, Heater.....	2
	9074-293-001	Cover-Plate, Heater.....	2
	9551-040-001	Side-Control Heater.....	4
	9545-008-024	Screw-10AB x 3/8.....	16
	9029-194-001	Bracket-Control, Heater.....	4
	9074-333-001	Cover-Control, Heater.....	2
	9545-018-014	Screw-1/4-20 x 3/4.....	8
	9277-041-014	Insulation.....	2
	9029-181-001	Bracket-Back, Panel.....	1
	9074-337-001	Cover-Terminal, Heater.....	2
	9576-207-006	Thermostat-Overtemp, Manual reset.....	2
	95368-166-005	Spacer Over Temp Thermostat.....	4
	9982-364-001	Plate Assembly-Overtemp switch.....	2
	9627-861-002	Harness-Over Temp Switch.....	2
	9348-066-001	Lever-Overtemp Switch.....	2
	9452-769-001	Plate-Over Temp Switch.....	2
	9497-229-001	Rod-Over Temp Switch.....	2
	9488-011-002	Rail-Din, 35 x 15mm.....	2

DDAD30HC_-64FN 400/3/50HZ

Key	Part Number	Discription	Qty
	5192-295-013	Relay.....	2
	5192-291-002	Relay, Heating Element 60 Amp.....	2
	9377-003-001	Varister-Coil Supressor.....	2
	5198-215-002	Circuit Breaker-3 Pole, 415V.....	4
	8652-134-002	Terminal-Lug, Solderless.....	4
	9870-095-002	Heater Element,	6
	9295-004-002	Jumper-Formed.....	4
	9295-005-002	Jumper-Straight.....	4
	9897-037-001	Block-Power, 3 Pole.....	2
	9897-038-001	Block-Power, 1 Pole.....	2
	9506-459-001	Wiring-Schematic.....	1
	9506-460-001	Wiring-Diagram.....	1
	9506-461-001	Wiring-Diagram/Schematic.....	1
	8514-202-001	Booklet-Owners, DDAD30HC_-16FC.....	1

