



DEXTER[®]
LAUNDRY

**USE THE BLUE TABS LOCATED ON THE
RIGHT AND LEFT SIDES OF THE FOLLOWING
DOCUMENT TO ADVANCE TO EACH SECTION.**

Wiring Harness Part # by Model

Key	Description	WCN25AA	WCN25AB	WCN40AA	WCN40AB	QTY
Use Following Items with Timer Part Number 9571-359-002						
*	Wiring Harness, Main	9627-680-002	9627-680-002	9627-680-002	9627-680-002	1
*	Wiring Harness, Control	9627-681-003	9627-681-003	9627-681-003	9627-681-003	1
Use Following Items with Timer Part Number 9571-361-002						
*	Wiring Harness, Drain Valve	9627-683-001	9627-683-001	9627-683-001	9627-683-001	1
*	Wiring Harness, Control	9627-694-001	9627-694-001	9627-694-001	9627-694-001	1
*	Wiring Harness, Main	9627-702-003	9627-702-003	9627-702-003	9627-702-003	1
*	Wiring Harness, Injector Control	9627-691-001	9627-691-001	9627-691-001	9627-691-001	1
*	Clamp, Cable- 1/4 Dia	8654-125-001	8654-125-001	8654-125-001	8654-125-001	1

Section 6:

Parts Data

N-Series Vended

Regular Chassis

- Models**
WCN25AADX
WCN25ABDX
WCN40AADX
WCN40ABDX

Cabinet and Front Panel Group Part # by Model WCN25AADX/WCN25ABDX

Key	Part Number	Description	MODELS	
			WCN25 A	WCN25 B
1	9454-656-001	Panel, Side (Left or Right) - Stainless.....	2	2
1	9454-656-003	Panel, Side (Left or Right) - Gray.....	2	2
*	9545-018-013	Screw, (Side Panel to Base).....	6	6
*	8640-414-006	Nut, Hex.....	6	6
*	9029-066-001	Bracket, Side Panel.....	1	1
*	8640-413-002	Nut, Hex.....	2	2
*	9545-008-026	Screw.....	2	2
2	9454-659-001	Panel Assy, Front.....	1	1
*	9059-063-002	Sand, Edge Protector	1	1
*	9545-008-026	Screw, Hex- To Control Panel.....	2	2
*	8640-399-008	Nut, Spring- To Control Panel.....	2	2
3	8502-624-002	Label, Door Opening.....	1	1
4	9545-008-014	Screw, Flat Head- Front to Sides.....	2	2
4	8641-585-001	Washer, Finish.....	2	2
*	8640-399-008	Nut, Spring- To Front Panel.....	2	2
*	9545-008-023	Screw, Guide.....	2	2
12	9989-458-001	Panel, Control (Mounts Nameplate).....	1	1
*	9545-008-006	Screw, Control Panel to Sides.....	4	4
11	9412-095-002	Nameplate, Control Panel (one piece).....	1	1
9	9454-663-001	Panel, Top.....	1	1
10	8650-012-003	Lock, Top (w/Key).....	1	1
*	6292-006-007	Key, Top-6324.....	1	1
*	9095-038-001	Cam, Lock-Top.....	1	1
*	8640-426-001	Nut, 9/32.....	1	1
*	8641-581-008	Washer.....	1	1
5	9108-097-001	Door, Lower Service.....	1	1
8	9244-081-002	Handle (bumper guard).....	1	1
*	9545-008-023	Screw, Guide	4	4
6	9545-008-014	Screw Mtg., Flat Head.....	2	2
6	8641-585-001	Washer, Finish.....	2	2
7	8640-399-008	Nut, Spring.....	2	2
15	9108-095-003	Door, Dispenser.....	1	1
*	9451-191-001	Pin, Plain.....	2	2
16	9467-025-001	Post, Door Mounting.....	2	2
*	9545-045-002	Screw, Dispenser Post Mtg.....	4	4
*	9545-008-012	Screw, Dispenser Mounting.....	4	4
*	8640-399-007	Nuts, Spring.....	4	4
*	9086-017-001	Catch, Top Panel.....	1	1
*	9467-024-001	Post, Top Locator.....	2	2
*	8640-411-003	Nut, Keps.....	2	2
*	9355-001-001	Locator, Panel.....	2	2
*	9545-008-025	Screw, #10.....	2	2
*	Not Illustrated			

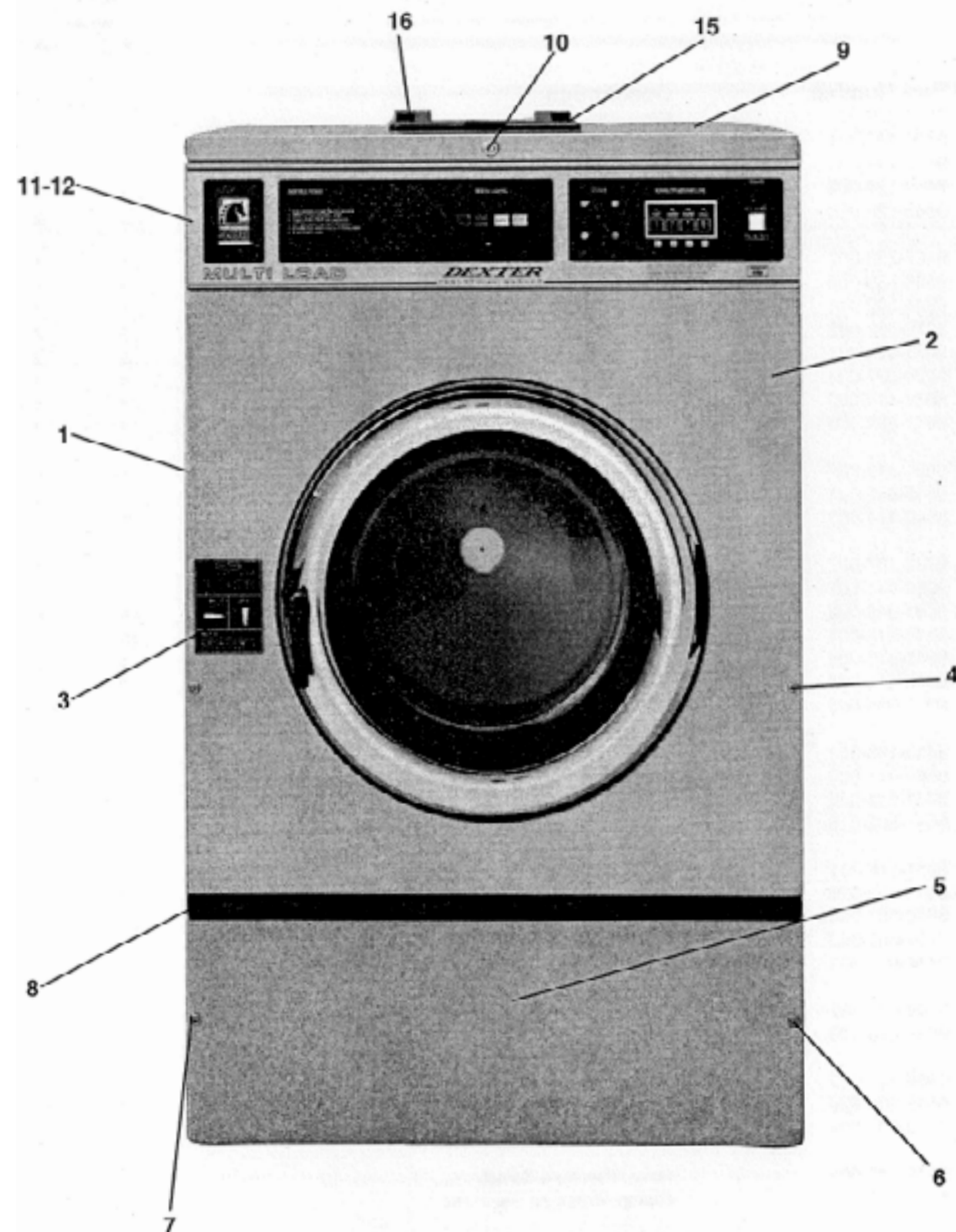

Cabinet and Front Panel Group Part # by Model WCN40AADX/WCN40ABDX

Key	Part Number	Description	MODELS	
			WCN40	
			A	A
			A	B
1	9989-449-001	Panel, Side (Left or Right)- Stainless	2	2
*	9545-018-013	Screw, (Side Panel to Base)	8	8
*	8640-414-006	Nut	8	8
*	9029-066-001	Bracket, Side Panel	1	1
*	8640-413-002	Nut, Hex #10	2	2
*	9545-008-026	Screw, #10	2	2
2	9454-669-003	Panel Assy, Front	1	1
*	9059-063-002	Band, Edge Protector (mounted to front panel)	1	1
*	8640-399-005	Nut, Spring- To Control Panel	2	2
*	9545-008-006	Screw, Hex- To Control Panel	2	2
3	9545-008-014	Screw, Flat Head	2	2
3	8641-585-001	Washer, Finish	2	2
3	8640-399-008	Nut, Spring	2	2
3	9545-008-023	Screw, Fillister Head Guide	2	2
4	8502-624-002	Label, Door Opening	1	1
8	9989-459-001	Panel, Control (Mounts Nameplate)	1	1
*	9545-008-026	Screw, Control Panel Mtg	4	4
7	9412-096-002	Nameplate, Control Panel.....	1	1
9	9454-664-001	Panel, Top	1	1
10	8650-012-003	Lock, Top (w/Key)	1	1
*	6296-006-007	Key, Top-6324	1	1
*	9095-038-001	Cam, Lock Top	1	1
*	8640-426-001	Nut, 9/32	1	1
*	8641-581-008	Washer	1	1
5	9108-097-001	Door, Lower Service	1	1
11	9244-081-002	Handle (bumper guard)	1	1
*	9545-045-010	Screw (mounting handle)	4	4
6	9545-008-014	Screw, Flat Head	2	2
6	8641-585-001	Washer, Finish	2	2
6	8640-399-008	Nut, Spring	2	2
*	9545-008-023	Screw, Fillister Head Guide Locating Front Panel	2	2
12	9108-095-003	Door, Dispenser	1	1
*	9451-191-001	Pin, Plain SS	2	2
*	9467-025-001	Post, Door Mounting	2	2
*	9545-045-002	Screw, Dispenser Post Mtg	4	4
*	9545-008-012	Screws, Dispenser Mounting	4	4
*	8640-399-007	Nuts, Spring	4	4
*	9086-017-001	Catch, Top Panel	1	1
*	9467-024-001	Top Panel Locator Posts	2	2
*	8640-411-003	Nut, Keps (for top panel locator posts)	2	2
*	9355-001-001	Locator, Panel	2	2
*	9545-008-025	Screw, #10	2	2

* Not Illustrated



Rear View Access Part # by Model

Key	Part Number	Description	MODELS WCN25	
			A	A
2	9732-127-001	Drive Motor, 1 Phase	1	
2	9732-127-002	Drive Motor, 3 Phase		1
4	9497-222-002	Rod, Motor Mtg	1	1
5	9545-029-005	Screw {end of motor rod}	1	1
5	8641-582-014	Lockwasher (end of motor rod)	1	1
6	9076-052-002	Collar, Shaft (w/set screws)	3	3
*	9053-074-001	Bushing, Motor Hangar (for Magnatek Motors).....	2	2
7	9029-027-003	Strap, Motor Tension.....	1	1
8	8640-413-002	Nut, Strap to Motor.....	1	1
8	8641-581-006	Washer.....	1	1
9	9534-319-002	Spring, Belt Tension.....	1	1
10	9545-055-001	Bolt, Eye.....	1	1
11	8640-414-003	Nut, 1/4 Elastic Stop.....	1	1
12	9732-137-002	Back Assy, Tub.....	1	1
13	9950-041-002	Ring Assy, Tub Mtg - Rear.....	1	1
14	9991-048-002	Support Assy, Bearing Housing.....	6	6
15	9545-029-003	Screw, 1 1/2	10	10
16	9545-029-006	Screw, 1 3/4.....	2	2
*	8640-415-004	Nut, Flange Lock.....	12	12
*	9552-038-003	Shim.....	AR	AR
3	9453-170-002	Pulley, Motor	1	1
*	9545-028-015	Set Screw, Sq, Hd.....	2	2
17	9453-168-004	Pulley, Driven	1	1
18	9545-017-009	Screw	1	1
18	8641-581-026	Washer, Flat	1	1
18	8641-582-016	Lockwasher	1	1
1	9040-076-005	Drive Belt	2	2
19	9081-115-001	Channel, Rear	1	1
*	9545-008-026	Screw	4	4
*	8640-399-004	Nut, Spring	4	4
*	9454-655-002	Panel, Back Guard.....	1	1
20	9454-663-001	Panel, Top.....	1	1
21	9242-449-002	Hose, Overflow	1	1
*	8654-029-000	Clamp, Hose	2	2
*	9989-446-002	Panel Assy., Back	1	1
*	9545-008-026	Screw	10	10
*	8640-399-004	Nut, Spring	10	10
22	9242-175-000	Hose, Pressure Switch	1	1
*	8654-117-015	Clamp, Pressure Sw. Hose	1	1
23	5198-211-004	Circuit Breaker, 1.5 amp.....	1	1
24	9242-463-002	Overflow hose - 11.....	1	1
*	Not Illustrated			

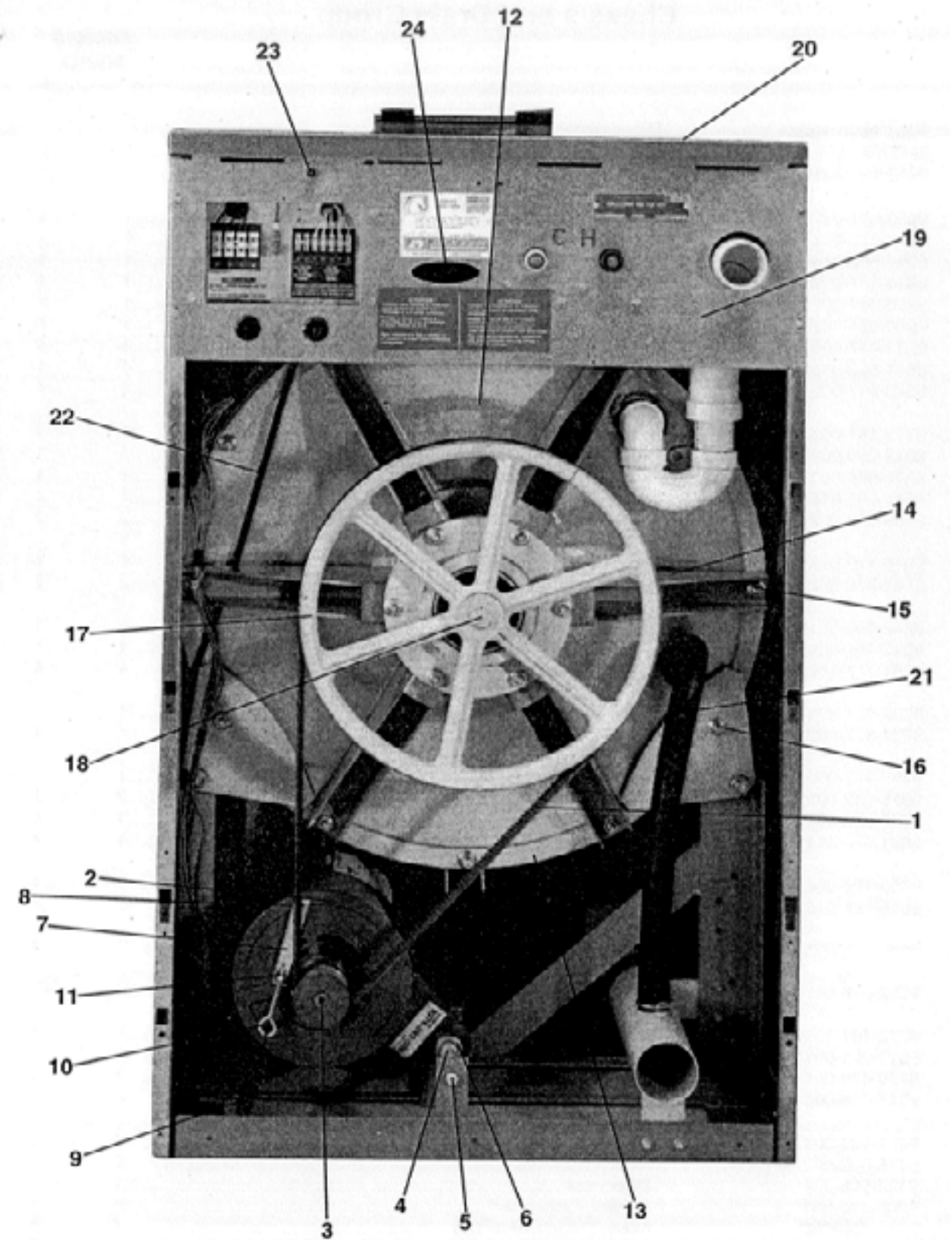

Rear View Access Part # by Model

Key	Part Number	Description	MODELS WCN40	
			A	B
1	9040-076-005	Drive Belt	2	2
2	9732-127-005	Drive Motor, 1 Phase.....	1	
2	9732-127-006	Drive Motor, 3 Phase		1
3	9453-170-002	Pulley, Motor	1	1
*	9545-028-015	Screw, set.....	2	2
4	9497-222-004	Rod, Motor Mtg.....	1	1
5	9545-029-005	Screw	1	1
5	8641-582-014	lockwasher.....	1	1
6	9076-052-002	Collar, Shaft {w/set screws)	3	3
*	9053-074-001	Nylon Bushing (For Magna-Tek Brand Motors).....	2	2
7	9029-027-003	Strap, Motor tension.....	1	1
8	8640-413-002	Nut, Strap to Motor	1	1
8	8641-581-006	Washer	1	1
9	9534-319-002	Spring, Belt Tension	1	1
10	9545-055-001	Bolt, Eye	1	1
11	8640-414-003	Nut, 114 20 Elastic Stop	1	1
13	9950-041-004	Ring Assy., Tub Mtg.- Rear.....	1	1
14	9991-051-002	Support Assy., Bearing Hsg	6	6
15	9545-059-002	Screw, 2"- Tub Back to Tub	12	12
*	8640-416-005	Nut, Flange Lock	12	12
*	9552-038-003	Shim.....	AR	AR
16	9453-168-003	Pulley, Driven	1	1
17	9545-060-001	Screw, Pulley to Shaft	1	1
17	8641-581-032	Washer, Flat	2	2
17	8641-582-018	lockwasher	1	1
21	9081-116-001	Channel, Rear	1	1
*	9545-008-026	Screw	4	4
*	8640-399-004	Nut, Spring	4	4
*	9454-655-001	Panel, Back Guard	1	1
19	9454-664-001	Panel, Top.....	1	1
20	9242-449-002	Hose, Overflow	1	1
*	8654-029-000	Clamp, Hose.....	2	2
*	9989-446-001	Panel Assy., Back	1	1
*	9545-008-026	Screw	10	10
*	8640-399-004	Nut, Spring	10	10
22	9242-175-002	Hose, Pressure Switch	1	1
*	8654-117-015	Clamp, Pressure Sw. Hose	1	1
23	9242-463-003	Overflow Vent Hose 12 1/4	1	1
24	9883-007-001	Injector Asseby PVC	1	1
*	0935-127-001	End Cap (For Chemical Injection Hose Insertion).....	1	1

* Not Illustrated

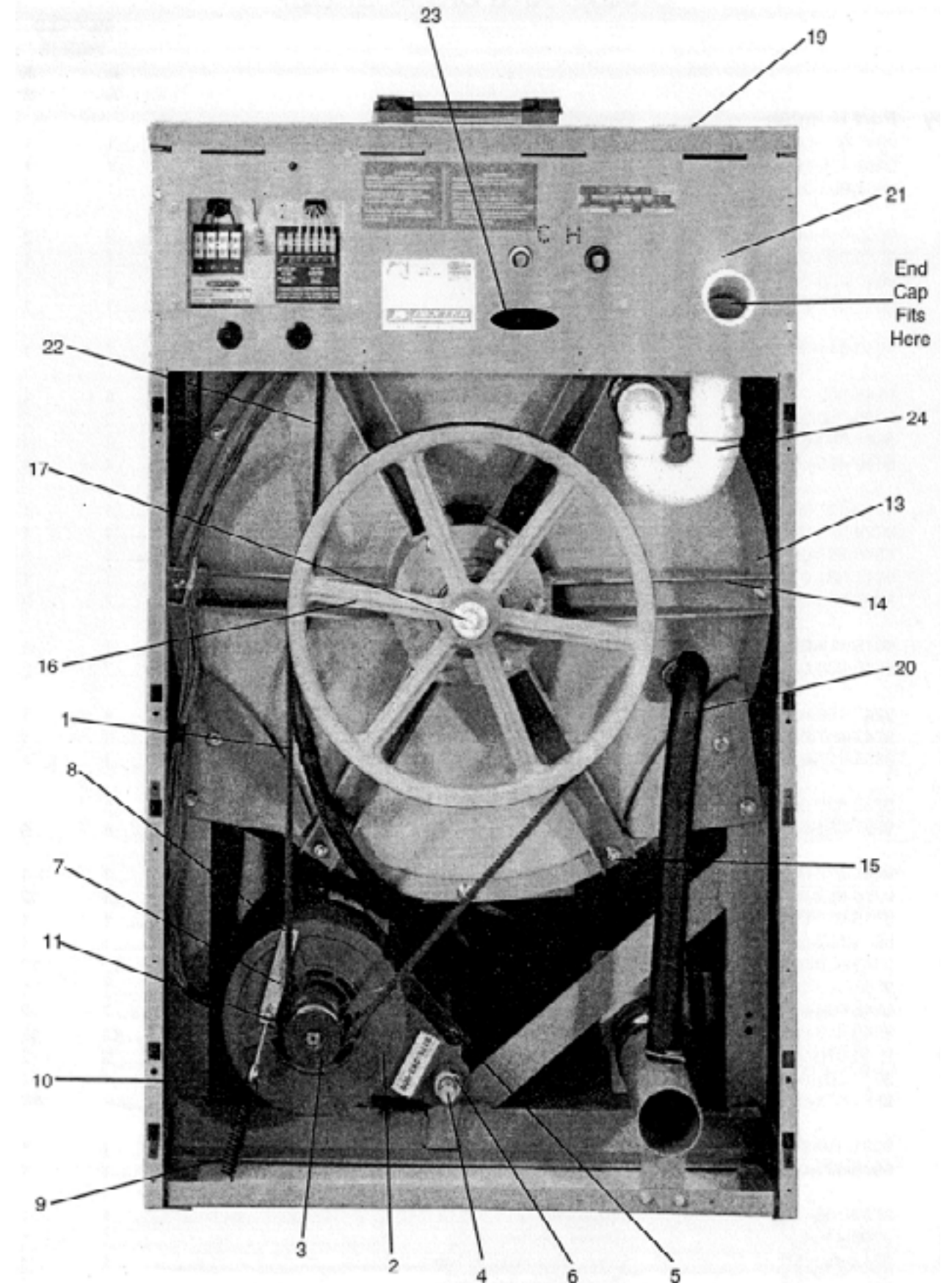

Cylinder, Seals & Bearings Part # by Model

Key	Part Number	Description	MODELS WCN25	
			A	B
*	9848-109-001	Cylinder Assy	1	1
*	9803-179-002	Housing, Bearing-Assembly (includes items 2-6)	1	1
2	9241-169-002	Housing, Bearing	1	1
3	9036-159-002	Bearing, Front	1	1
4	9036-159-001	Bearing, Rear	1	1
5	9538-158-001	Spacer, Bearing	1	1
6	9487-238-001	Ring, Bearing Retainer (internal type)	1	1
7	9732-137-002	Back Assy, Tub	1	1
8	9532-140-006	Seal, Secondary	1	1
9	9532-140-009	Seal, Primary	1	1
10	9950-042-001	Ring, Seal Mtg	1	1
11	9487-261-002	Tub Back Mating Ring	1	1
11	9732-137-002	Kit, Tub Back (2-piece kit must be used before #429963)	1	1
12	9545-017-009	Bolt, 1/2" Tub End of Bearing Housing (1/2x1 1/4)	6	6
12	8640-417-002	Nut	6	6
12	8641-582-016	Lockwasher 1/2 (ext tooth)	6	6
13	9991-048-002	Support Arm Assy, Bearing Housing	6	6
14	9545-029-003	Bolt, Pulley End of Bearing Housing (3/8x1 1/2)	6	6
14	8640-415-004	Nut, Flange Locking 3/8	1	1
*	9545-029-006	Bolt 3/8x1 1/2	2	2
15	9453-168-002	Pulley, Driven (old style - one belt, before #425720)	1	1
15	9453-168-004	Pulley, Driven (new style - two belt, after #425720)	1	1
*	9487-234-001	Ring, Tolerance	1	1
16	8641-581-026	Washer 1/2	1	1
17	9545-017-009	Bolt (1/2x1 1/4)	1	1
18	8641-582-016	Lockwasher 1/2 Ext Tooth	1	1

*Not Illustrated

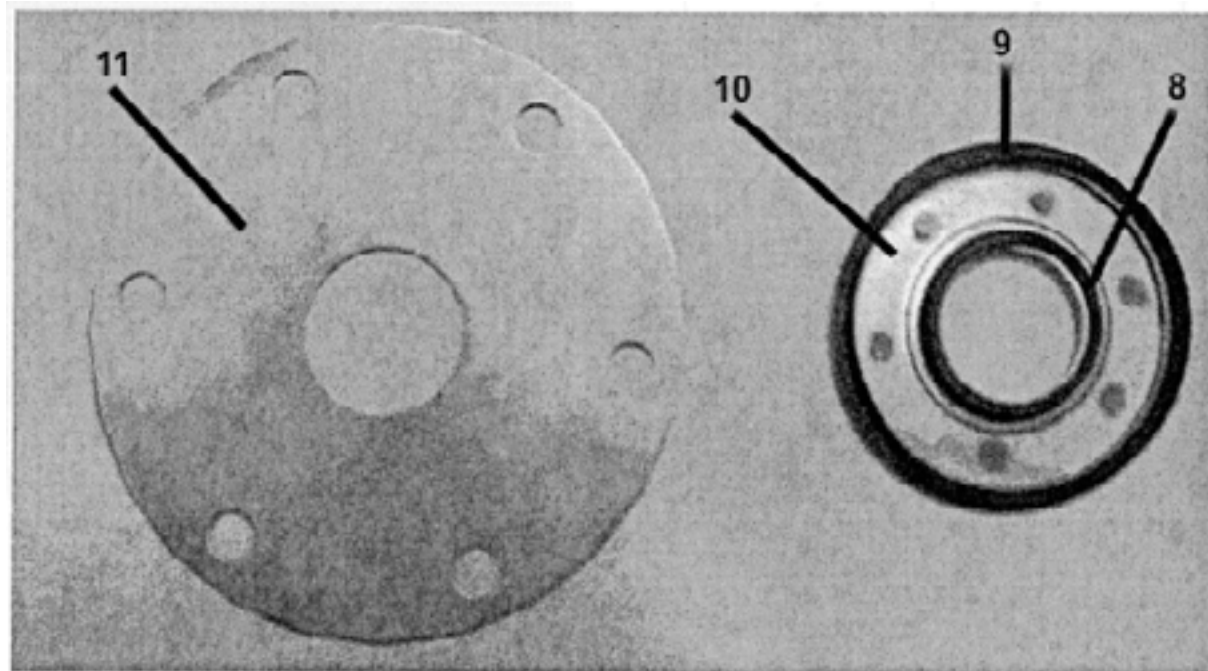

Cylinder, Waterseals, Bearing Housing and Pulley Group

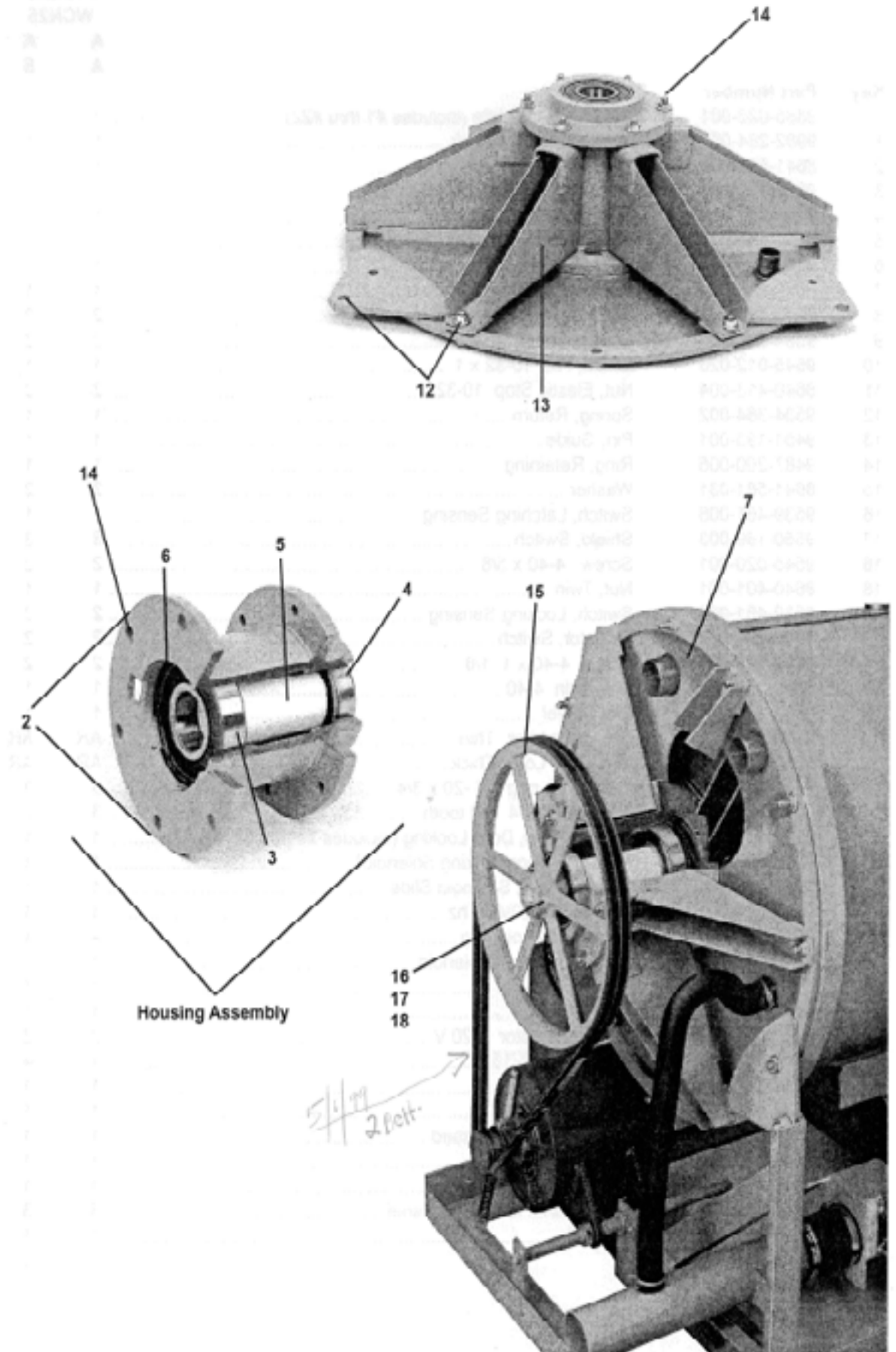

Cylinder, Seals & Bearings Part # by Model

Key	Part Number	Description	MODELS WCN40	
			A	B
1	9848-113-001	Cylinder Assy	1	1
*	9803-186-001	Housing, Bearing-Assembly (includes items 2-6)	1	1
2	9241-180-002	Housing, Bearing	1	1
3	9036-159-005	Bearing, Front	1	1
4	9036-159-004	Bearing, Rear	1	1
5	9538-167-001	Spacer, Bearing	1	1
6	9487-238-003	Ring, Bearing Retainer (internal type)	1	1
7	9732-137-004	Back Assy, Tub	1	1
8	9532-140-006	Seal, Secondary	1	1
9	9532-140-009	Seal, Primary	1	1
10	9950-042-001	Ring, Seal Mtg	1	1
11	9487-261-002	Tub Back Mating Ring	1	1
11	9732-137-003	Kit, Tub Back	1	1
12	9545-060-001	Bolt, 5/8x1 1/2 Tub End of Bearing Housing	6	6
12	8640-425-001	Nut 5/8	6	6
12	8641-582-018	Lockwasher 1/2 (ext tooth)	6	6
13	9991-051-002	Support Arm Assy, Bearing Housing	6	6
14	9545-059-003	Bolt, Pulley End of Bearing Housing (7/16x1 1/2)	6	6
14	8640-416-005	Nut, Flange Locking 7/16	6	6
15	9453-168-003	Pulley, Driven	1	1
16	9487-234-003	Ring, Tolerance	1	1
17	8641-581-032	Washer 1/2	1	1
18	9545-060-001	Bolt (5/8x1 1/2)	1	1
19	8641-582-018	Lockwasher 1/2 Ext Tooth	1	1

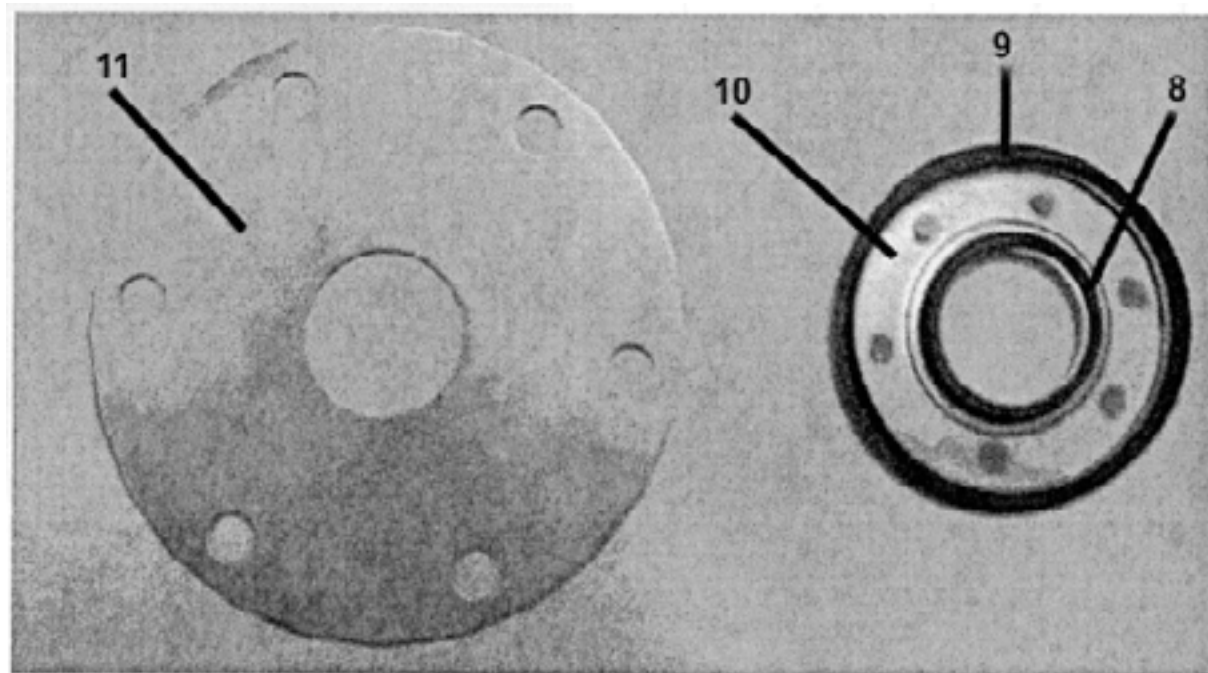

Cylinder Water Seals and Bearing Housing and Pulley Group

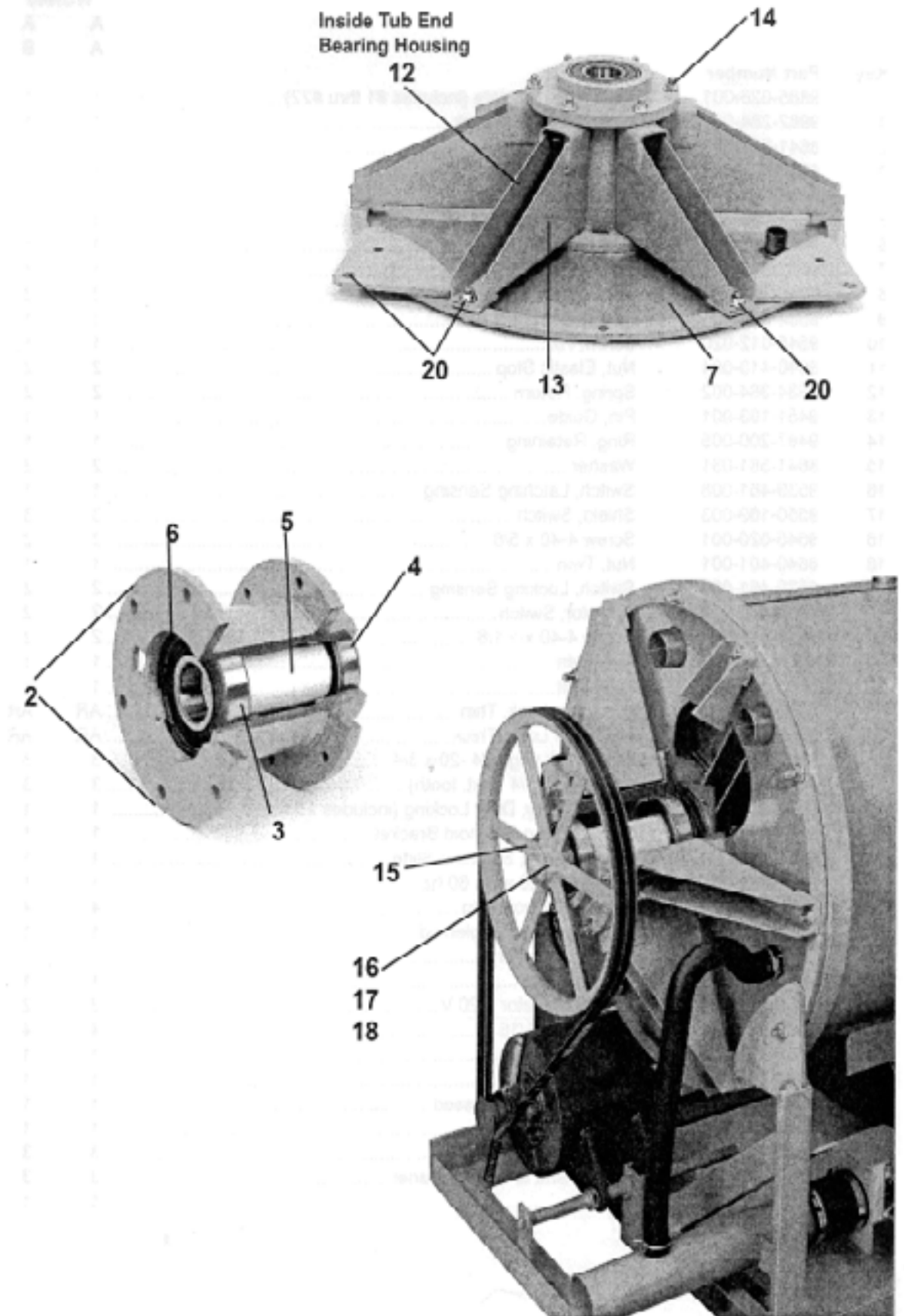

Door Latching & Solenoid Door Lock Assemblies by Part

Key	Part Number	Description	Qty
*	9885-023-001	LockAssy, Complete (includes #1 thru #22)	1
1	9982-284-001	Plate Assy, Door Lock	1
2	8641-581-030	Washer, Flat	1
3	9008-005-001	Actuator, Latching Switch	1
4	9450-002-002	Pawl, Locking	1
5	8641-569-003	Washer, Spring	1
6	9487-200-004	Ring, Ret Jning	1
7	9029-035-001	Bracket; SOWiitch	1
8	8640-413-002	Nut, Hex 10-32 UNF	2
9	9534-364-001	Spring, Actuating	2
10	9545-012-020	Screw, Hx. 10-32 x 1	1
11	8640-413-004	Nut, E.lastic Stop 10-32	2
12	9534-364-002	Spring, Return	1
13	9451-193-001	Pin, Guide	1
14	9487-200-005	Ring, Retaining	1
15	8641-581-031	Washer	2
16	9539-461-008	Switch, Latching Sensing	1
17	9550-169-003	Shield, Switch	3
18	9545-020-001	Screw 4-40 x 5/8	2
18	8640-401-001	Nut, Twin	1
19	9539-461-007	Switch, Locking Sensing	2
20	9008-006-002	Actuator, Switch	2
21	9545-020-003	Screw 4-40 x 1 1/8	2
21	8640-401-001	Nut, Twin 4-40	1
22	9451-181-004	Pin, Dowel	1
*	9552-037-001	Shim, Door Lock, Thin	AR
*	9552-037-002	Shim, Door Lock, Thick	AR
*	9545-018-014	Screw, Lock mtg 1/4 -20 x 3/4	3
*	8641-582-007	Lockwasher 1/4 Ext tooth	3
*	9922-011-001	Solenoid Ass'y, Door Locking (includes 23 thru 32)	1
23	9029-073-001	Bracket, {Door Locking Solenoid)	1
24	9985-169-001	BracketAss'y, Soienoid Slide	1
25	9536-074-001	Solenoid 120V 60 hz	1
26	9545-008-001	Screw, Solenoid Mtg	4
27	9540-033-002	Stop, Door Lock Solenoid	1
28	9545-061-001	Screw, Shoulder	1
28	8640-411-003	Nut, Keps #6	1
29	9586-001-001	Thermoactuator 120 V	2
30	9545-031-011	Screw. #6 x5/16	4
31	9538-157-004	Spacer, Plastic	1
31	9538-166-004	Spacer, Metal	1
31	9545-010-001	Screw, Cross Recessed	1
31	8640-412-005	Nut, Keps #8	1
32	8640-411-002	Nut, Keps#6	1
*	8640-412-005	Nut, Sol.Brkt. to Control. Panel	3
*	9497-225-006	Rod, Pull	1

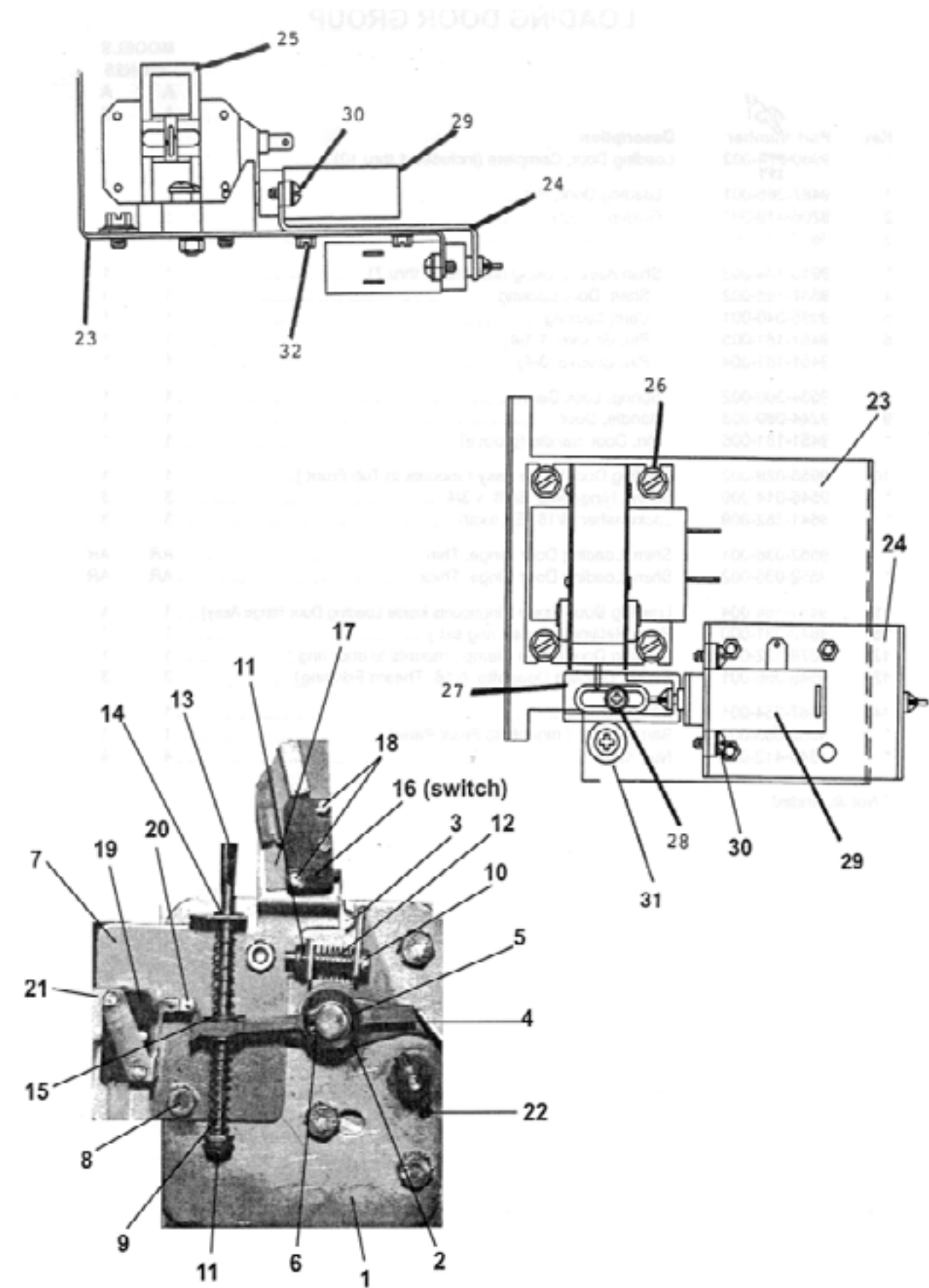

Loading Door Part # by Model

Key	Part Number	Description	Qty
*	9960-259-002	Loading Door, Complete (includes 1 thru 10)	1
1	9487-230-001	Loading Door, Ring	1
2	9206-419-001	Gasket, Loading Door	1
3	9635-016-001	Window, Loading Door	1
4	9913-134-003	Shaft Assy, Locking (includes 4 thru 7)	1
*	9537-195-002	Shaft, Door Locking	1
5	9095-040-001	Cam, Locking	1
6	9451-181-005	Pin, Groove (1 1/4)	1
7	9451-181-004	Pin, Groove (3/4)	1
8	9534-360-002	Spring, Lock Cam	1
9	9244-080-003	Handle, Door	1
*	9451-181-006	Pin, Door Handle (Groove)	1
*	9545-014-009	Screw, Hinge Mtg	3
*	8641-582-009	Lockwasher 5/16	3
*	9552-036-001	Shim, Loading Door Hinge (Thin)	AR
*	9552-036-002	Shim, Loading Door Hinge (Thick)	AR
10	9955-028-003	Hinge Assy, Loading Door (Mounts to tub front)	1
11	9451-184-003	Pin, Loading Door Hinge (Fits inside loading door hinge)	1
12	9079-122-002	Clamp, Loading Door Hinge	1
13	9545-056-001	Screw, Loading Door Mtg	3
14	9487-254-001	Ring, Masking	1
*	8640-413-002	Nut	4
*	9059-063-001	Band, Edge Protector (Mounted to front panel)	1

*Not illustrated

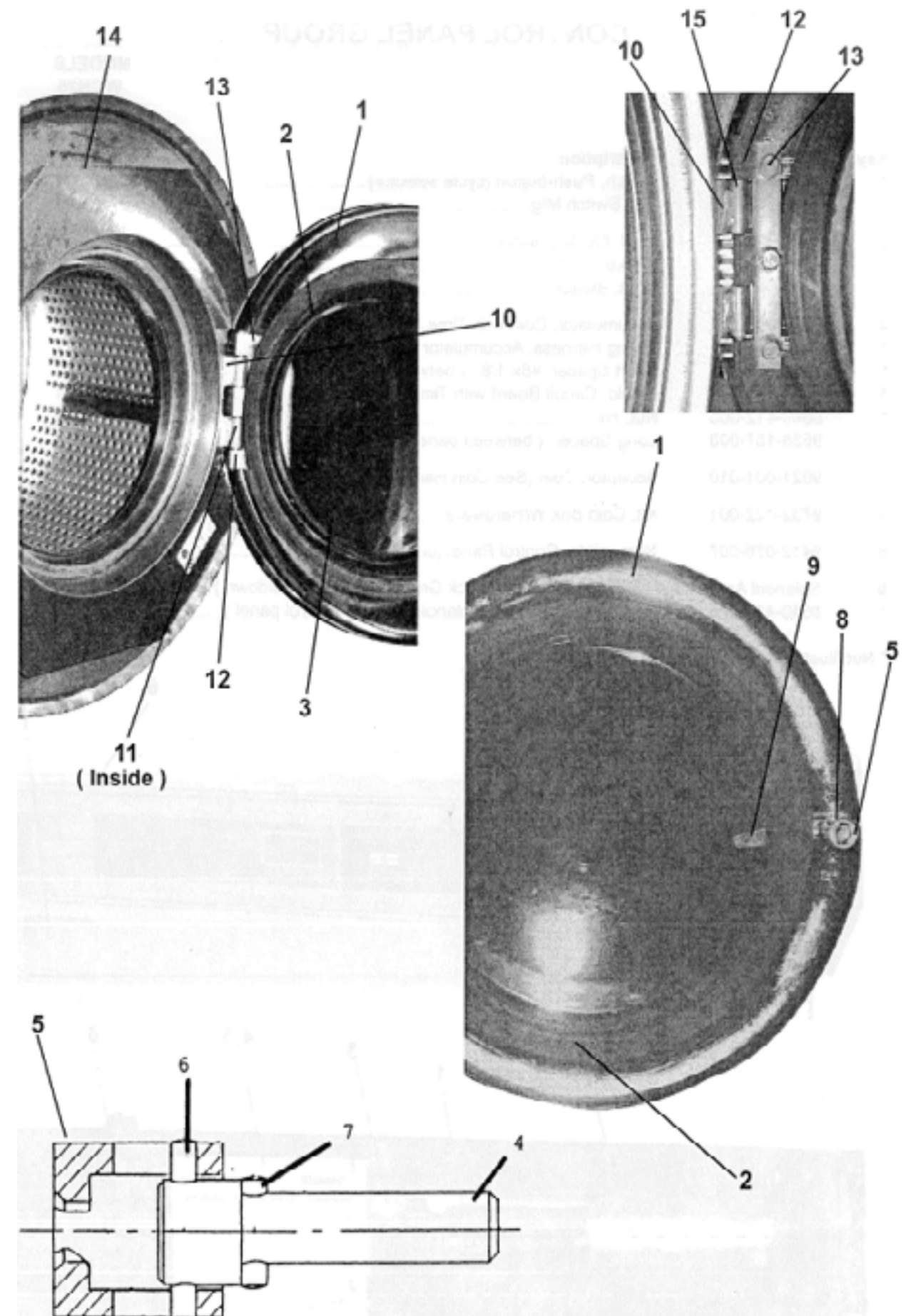

Notes

Drain Valve Group Part # by Model

Key	Part Number	Description	Qty
*	9379-187-001	Valve, Drain (includes 2 thru 11)	1
*	9379-202-001	Replacement Drain Valve	1
2	9064-070-001	Body, Valve (w/ball)	1
3	9914-137-001	Motor & Gear Train	1
4	9452-538-001	Plate, Motor Mtg	1
5	8639-994-001	Screw	3
6	9534-339-001	Spring, Drive	1
7	9545-054c001	Screw	2
8	9545-054-002	Screw	1
9	9532-134-001	Seal, V Packer	2
10	8641-584-001	Washer	1
11	9451-196-001	Pin, Main Drive	1
12	9538-149-001	Plate (spacers needed for replacement motor mtg. plate)	4

* Not illustrated

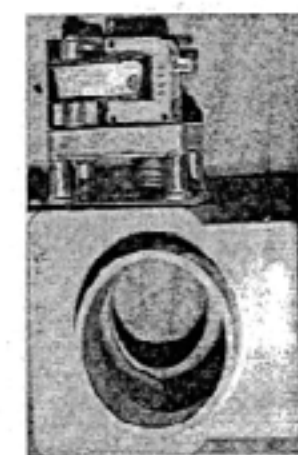
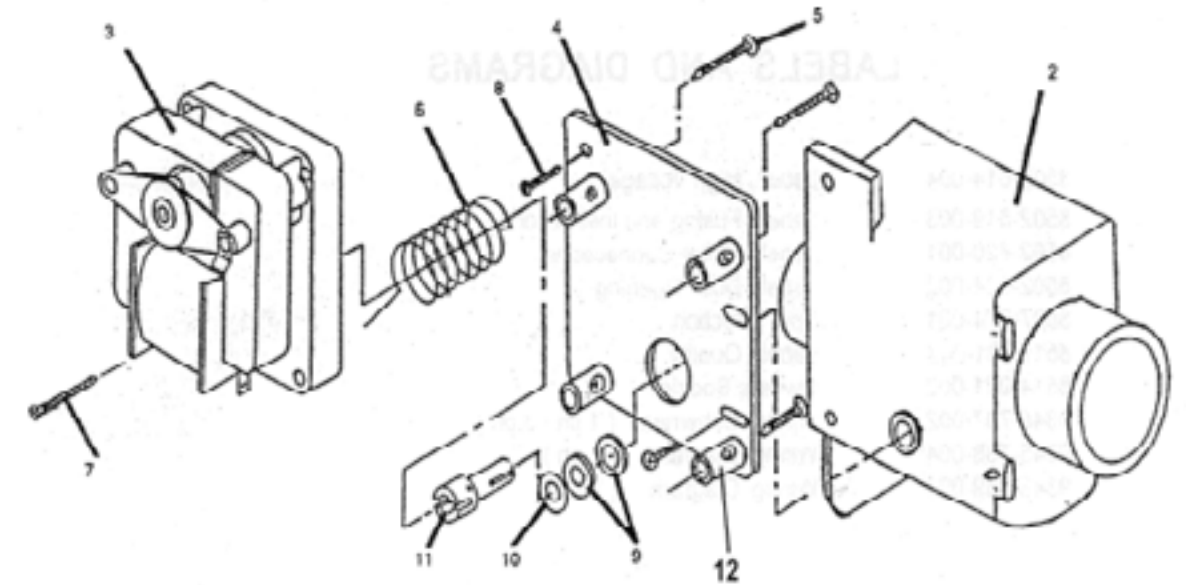

Valve Complete

Chassis and Drain Part # by Model

Key	Part Number	Description	MODELS	
			W	CN25
1	9945-087-002	Base Assy, Frame	1	1
2	9930-137-001	Tub Assy	1	1
3	9950-051-002	Ring Assy, Tub Mtg-Front	1	1
4	9545-017-003	Bolt, Top Front Ring	1	1
4	8641-582-016	Lockwasher	1	1
4	8640-417-002	Nut.	1	1
5	9950-041-002	Ring Assy, Tub Mtg-Rear	1	1
5a	9950-054-002	Ring Ass'y--Seal Tubback	1	1
6	9545-017-009	Screw, Front & Rear Rings to Base	4	4
6	8641-582-016	Lockwasher	4	4
6	8640-417-002	Nut.	4	4
7	9379-187-001	Valve, Drain	1	1
8	9029-056-001	Bracket, Drain Valve	1	1
*	9545-048-001	Screw, Valve to Bracket	1	1
*	8641-581-018	Washer	1	1
9	9545-030-002	Screw, Bracket to Base	2	2
10	9915-119-002	Tube Assy, Drain	1	1
10a	9545-.030-002	Screw, Tube Mtg	2	2
11	9242-456-001	Hose, Tub to Drain Valve	1	1
12	9242-457-001	Hose, Drain Valve to Tube	1	1
12a	8654-117-014	Clamp, Hose	4	4
13	9732-127-001	Motor, Drive (1 PH)	1	
13	9732-127-002	Motor, Drive (3 PH)		1
14	9497-222-002	Rod, Motor Mtg	1	1
15	9076-052-002	Collar, Shaft	2	2
16	9545-029-005	Screw, Motor Mtg Rod	1	1
16	8641-582-014	Lockwasher	1	1
17	9453-168-004	Pulley, Motor	1	1
*	9545-028-015	Set Screw, Sq. Hd	2	2
18	9040-076-005	Belts, Drive	2	2
*	9552-038-003	Shim, Support Assembly	AR	AR
19	9242-461-001	Hose, Vacuum Brkr. to Tub	1	1
20	9610-001-001	Vacuum Breaker	1	1
21	9029-078-001	Bracket, Vacuum Breaker	1	1
22	9545-008-005	Screw	4	4
*	9081-104-001	Channel, Rear	1	1
*	9475-002-002	Flow Restrictors	2	2
23	9122-005-004	Dispenser	1	1
24	9206-416-001	Gasket, Dispenser	1	1
25	9242-450-002	Hose, Dispenser to Tub	1	1
26	8654-117-008	Clamp, Dispenser Hose	2	2
25	9242-463-002	Overflow Vent hose 11	1	1

*Not illustrated

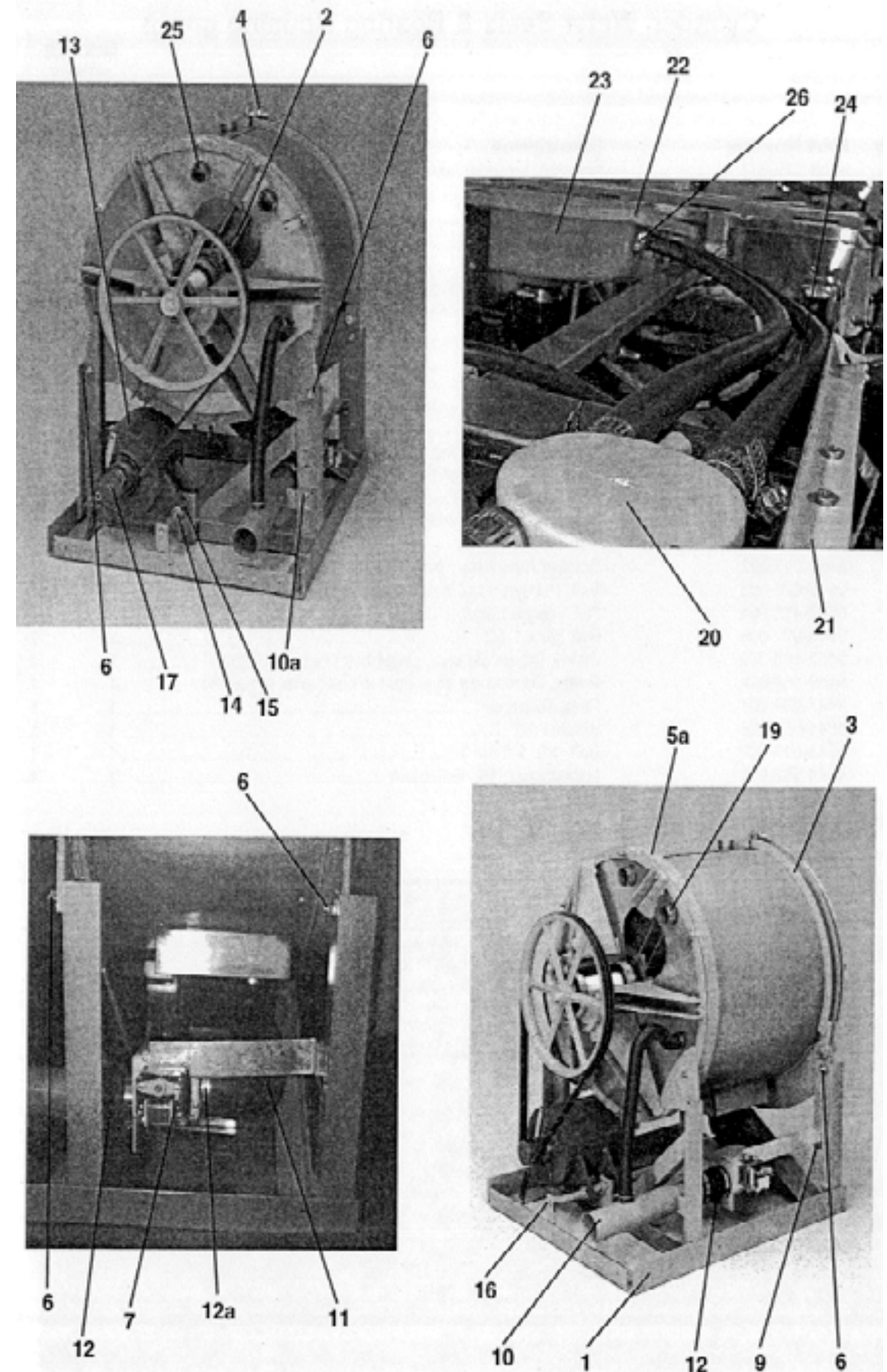

Chassis and Drain Part # by Model

Key	Part Number	Description	MODELS	
			WCN40	
			A	A
			A	B
1	9945-097-002	Base Assy, Frame	1	1
2	9930-136-001	TubAssy	1	1
3	9967-009-002	Cradle Assy, Tub	1	1
4	9950-050-002	Ring Assy, Tub Mtg-Front	2	2
5	9545-060-003	Screw, 5/8-3x 1	1	1
5	8640-425-011	Nut	1	1
5	8641-582-018	Lockwasher	1	1
6	9950-041-004	Ring Assy., Tub Mtg.- Rear	1	1
7	9545-060-002	Bolt, 5/8-11x1 1/2 Rings to Base (front & rear)	4	4
8	9545-060-001	Bolt, 5/8-11x2 1/2 Rings to Base (front ring to cradle}	2	2
*	8641-582-018	Lockwasher	4	4
*	8640-425-001	Nut, Hex	4	4
9	9379-187-001	Valve, Drain	1	1
11	9029-052-001	Bracket, Drain Valve	1	1
*	9545-048-001	Screw, Valve to Bracket	1	1
*	8641-581-018	Washer	1	1
*	9545-030-002	Screw, Bracket to Base	2	2
12	9915-118-002	Tube Assy, Drain	1	1
*	9545-030-002	Screw, Tube Mtg	2	2
14	9242-456-001	Hose, Tub to Drain Valve	1	1
15	9242-457-001	Hose, Drain Valve to Tube	1	1
16	8654-117-014	Clamp, Hose	4	4
17	9732-137-003	BackAssyTub	1	1
18	9991-051-002	Support Arm Assembly	6	6
*	9497-222-004	Rod, Motor Mtg	1	1
*	9076-052-002	Collar, Shaft	2	2
*	9545-029-005	Screw, Motor Mtg Rod	1	1
*	8641-582-014	Lockwasher	1	1
19	9545-059-002	Bolt 7/16 x 2 Tub Back to Tub	12	12
*	9453-170-002	Pulley, Motor	1	1
*	9545-028-015	Set Screw, Square Head	2	2
*	8640-416-005	Nut, Flange Lock	12	12
25	9040-076-005	Belt, Drive	2	2
20	9610-001-001	Vaccum Breaker	1	1
*	9552-038-001	Shim, Support Assembly	AR	AR
*	9081-116-001	Channel, Rear	1	1
*	0935-127-001	End Cap for liquid chemical injections	1	1
21	9732-105-004	Dispenser,	1	1
22	9206-416-001	Gasket, Dispenser	1	1
24	9242-450-001	Hose, Dispenser to Tub	1	1
23	8654-117-008	Clamp, Dispenser Hose	2	2

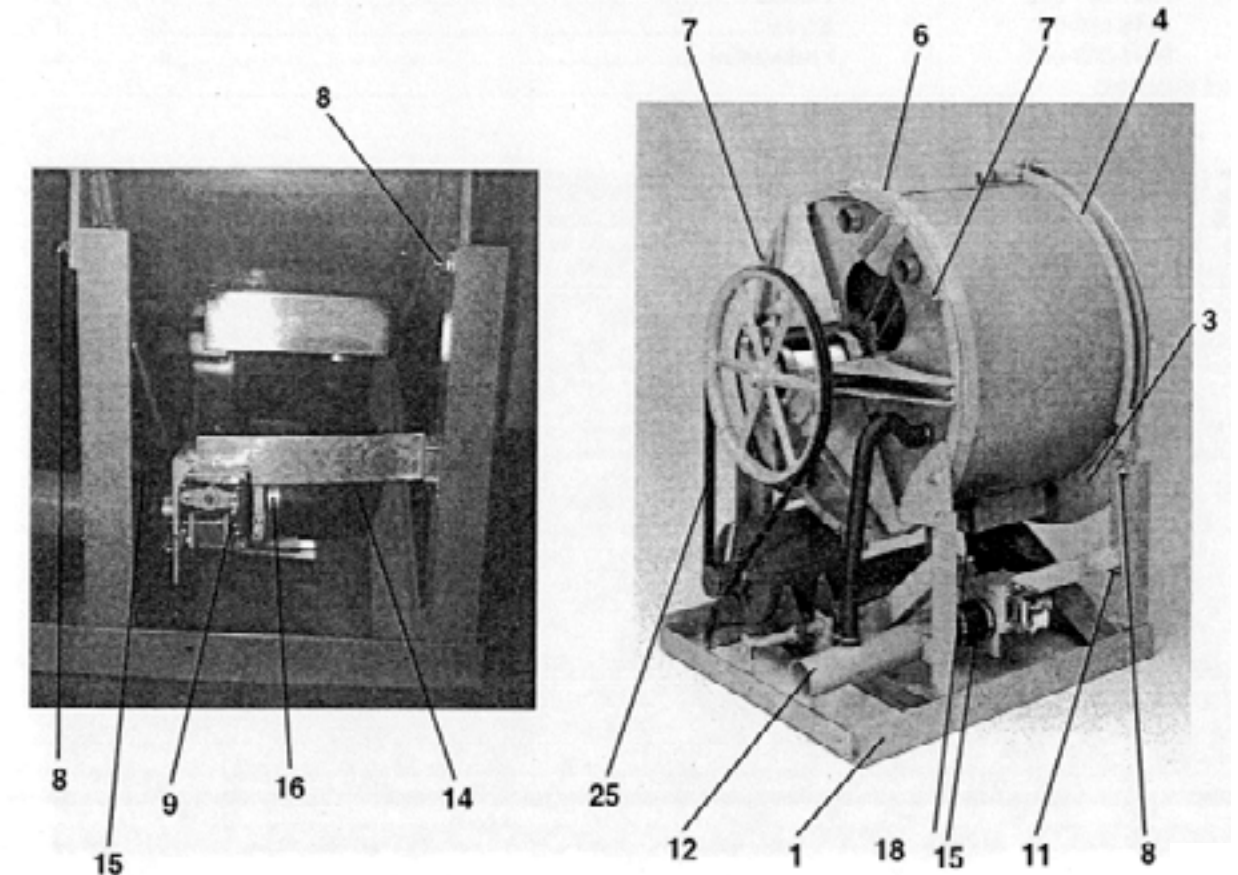
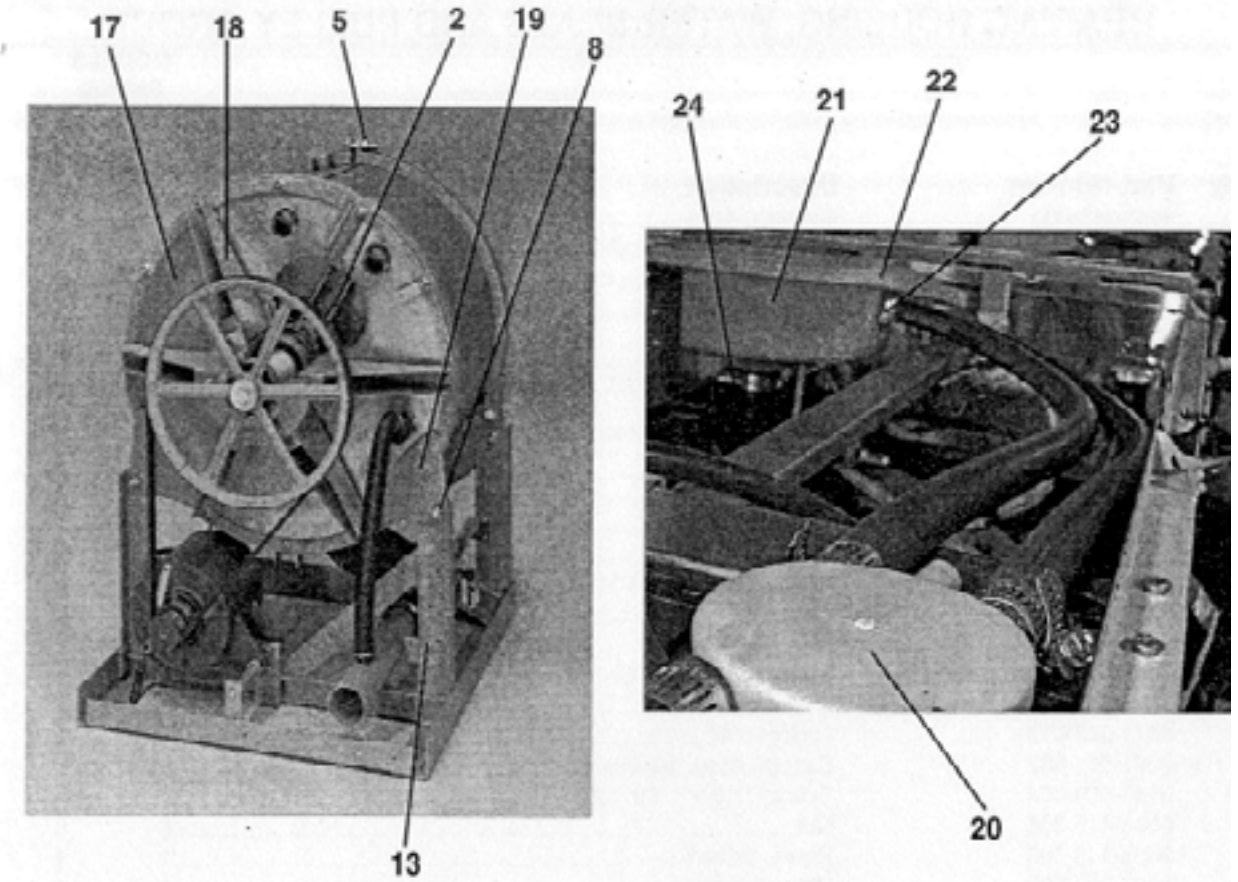

Water Inlet & Rear Channel

Key	Part Number	Description	MODELS WCN25	
			A	A
1	9379-183-012	Valve, Water Inlet (see Water Inlet Valve Breakdown for individual parts)	2	2
*	9545-008-026	Screw, Valve Mtg	4	4
*	8640-399-009	Nut, Spring	4	4
2	9610-001-001	Vacuum Breaker	1	1
*	9029-078-001	Bracket, Vacuum Breaker	1	1
3	9545-008-026	Screw	4	4
12	9242-461-001	Hose, Vacuum Breaker to Injector	1	1
*	8654-117-008	Clamp, Vacuum Breaker End	1	1
*	8654-117-008	Clamp, Tub End	1	1
4	9242-453-017	Hose, Vac. Brkr. to Wash Disp. 18 1/4	1	1
5	9242-453-016	Hose, Vac. Brkr. to Rinse Disp. 14 1/2	1	1
6	9242-453-020	Hose, Hot Valve to Vac. Brkr 18	1	1
7	9242-453-020	Hose, Hot Valve to Tub 18	1	1
8	9242-453-020	Hose, Cold Valve to Vac. Brkr 18	1	1
9	9242-453-020	Hose, Cold Valve to Tub 18	1	1
*	8654-029-000	Clamp, Hose-Spring (overflow from drain to tub back)	2	2
*	8654-117-009	Clamp, Hose	1	1
10	8654-117-015	Clamp, Hose-Worm	10	10
*	9883-006-001	Injector Assy (PVC)	1	1
*	9242-463-002	Hose, Overflow	1	1
*	9242-462-001	Hose, Injector to Tub	1	1

*Not illustrated

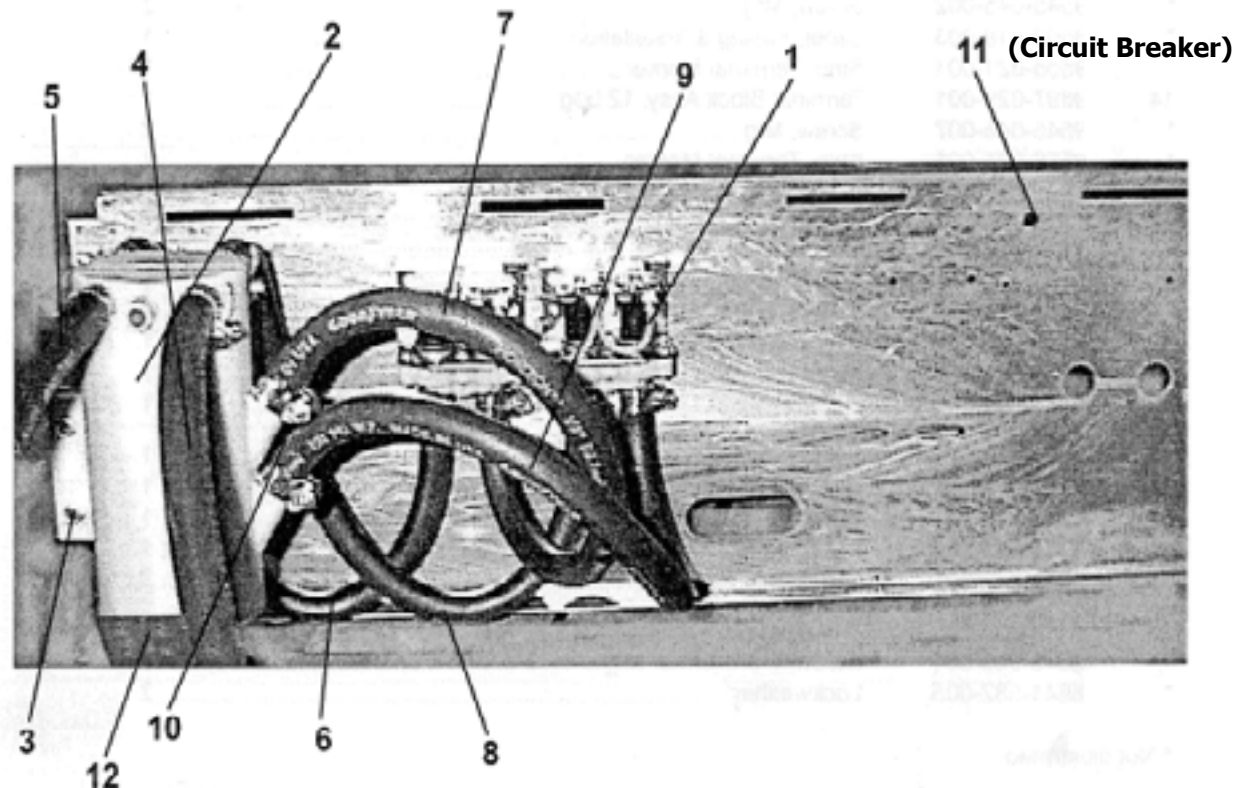

Water Inlet & Rear Channel

Key	Part Number	Description	MODELS WCN40	
			A	A
1	9379-183-003	Valve, Water Inlet (see Water Inlet Valve Breakdown for individual parts)	2	2
*	9545-008-026	Screw, Valve Mtg	4	4
*	8640-399-006	Nut, Spring	4	4
2	9610-001-001	Vacuum Breaker	1	1
*	9029-069-001	Bracket, Vacuum Breaker	1	1
3	9545-008-026	Screw	4	4
4	9242-461-001	Hose, Injector to Vacuum Breaker	1	1
*	8654-117-008	Clamp, Vac. Brkr. End	1	1
*	8654-117-009	Clamp, Tub End	1	1
5	9242-453-008	Hose, Vacuum Breaker to Wash Dispenser 26	1	1
6	9242-453-009	Hose, Vacuum Breaker to Rinse Dispenser 23	1	1
7	9242-453-020	Hose, Hot Valve to Vacuum Breaker 18	1	1
8	9242-453-020	Hose, Hot Valve to Tub 18	1	1
9	9242-453-020	Hose, Cold Valve to Vacuum Breaker 18	1	1
10	9242-453-020	Hose, Cold Valve to Tub 18	1	1
*	9242-462-001	Hose, Injector to Tub	1	1
*	8654-117-015	Clamp, Hose Worm	13	13
*	9883-007-001	Injector Assy PVC	1	1
*	9242-463-003	Hose, Overflow	1	1
*	0935-127-001	End Cap	1	1

* Not Illustrated

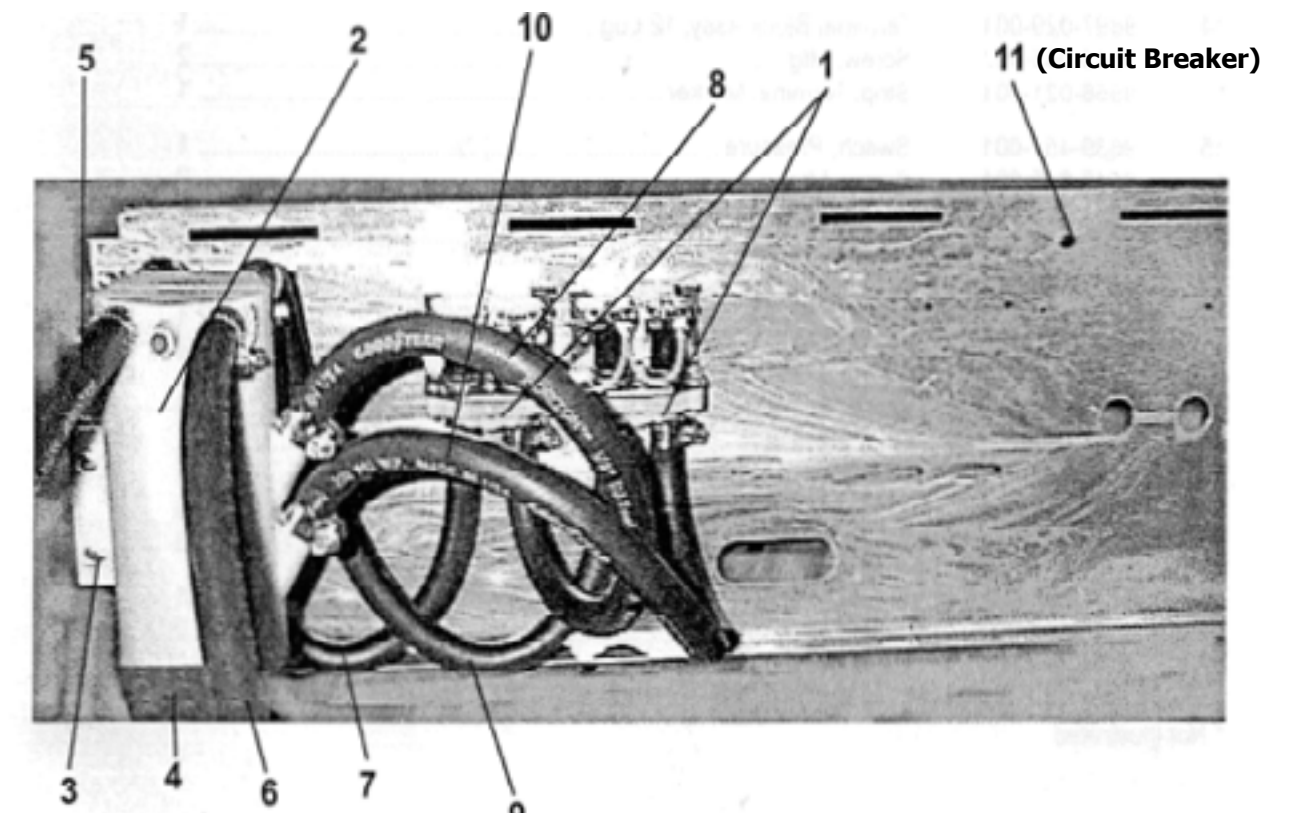

Electrical Components - Top Compartment WCN25AA - Single Phase Only

Key	Part Number	Description	Qty
1	9839-012-003	Trough Assy, Controls Mtg	1
*	9545-008-005	Screw, Trough Sides	2
*	9029-064-001	Bracket, Trough to Rear Channel	1
*	9545-008-001	Screw, Trough Bracket	3
1a	9029-061-001	Front Trough Bracket (control panel to front)	1
2	5191-102-005	Capacitor, Spin-Start (Century) (plastic)	1
3	5191-103-010	Capacitor, Run-Tumble (Century) (metal)	1
4	9544-049-002	Strap, Capacitor Mtg (Century)	1
*	9545-045-001	Screw, Capacitor Strap	2
5	5192-286-007	Relay, RUN	2
6	5192-286-008	Relay, Spin	1
7	9571-361-004	Timer, Program (VERIFY PART NUMBER ON TIMER BODY)	1
*	9376-295-004	Motor, Timer Main Drive	1
*	9376-286-004	Motor, Timer Rapid Advance	1
*	9545-012-001	Screw, Timer Mtg	2
8	9107-067-001	Dial, Timer	1
9	9307-176-001	Knob, Timer (w/set screws)	1
10	9571-360-001	Timer, Reversing	1
*	9545-044-004	Screw, Reversing Timer	2
11	9897-033-002	Terminal Block, Power Connection	1
*	9545-045-007	Screw, Mtg	2
*	8502-619-003	Label, Fusing	1
12	9897-034-001	Terminal Block Assy,	1
*	9545-045-007	Screw, Mtg	2
*	9558-022-001	Strip, Terminal Marker	1
13	5192-285-001	Relays	2
14	9539-489-001	Switch, Pressure	1
*	9545-045-001	Screw, Mtg	2
*	5198-211-004	Circuit Breaker, 1.5 amp	1
*	8652-130-037	Lug, Grounding	1
*	8639-621-007	Screw, Mtg	1
*	8641-582-006	Lockwasher	1
16	9539-478-002	Solid State Start Switch	1
*	9029-062-001	Strap, Mtg	1
*	9545-010-001	Screw	1
*	8640-412-005	Nut	1
*	9545-031-003	Screw	1

* Not Illustrated

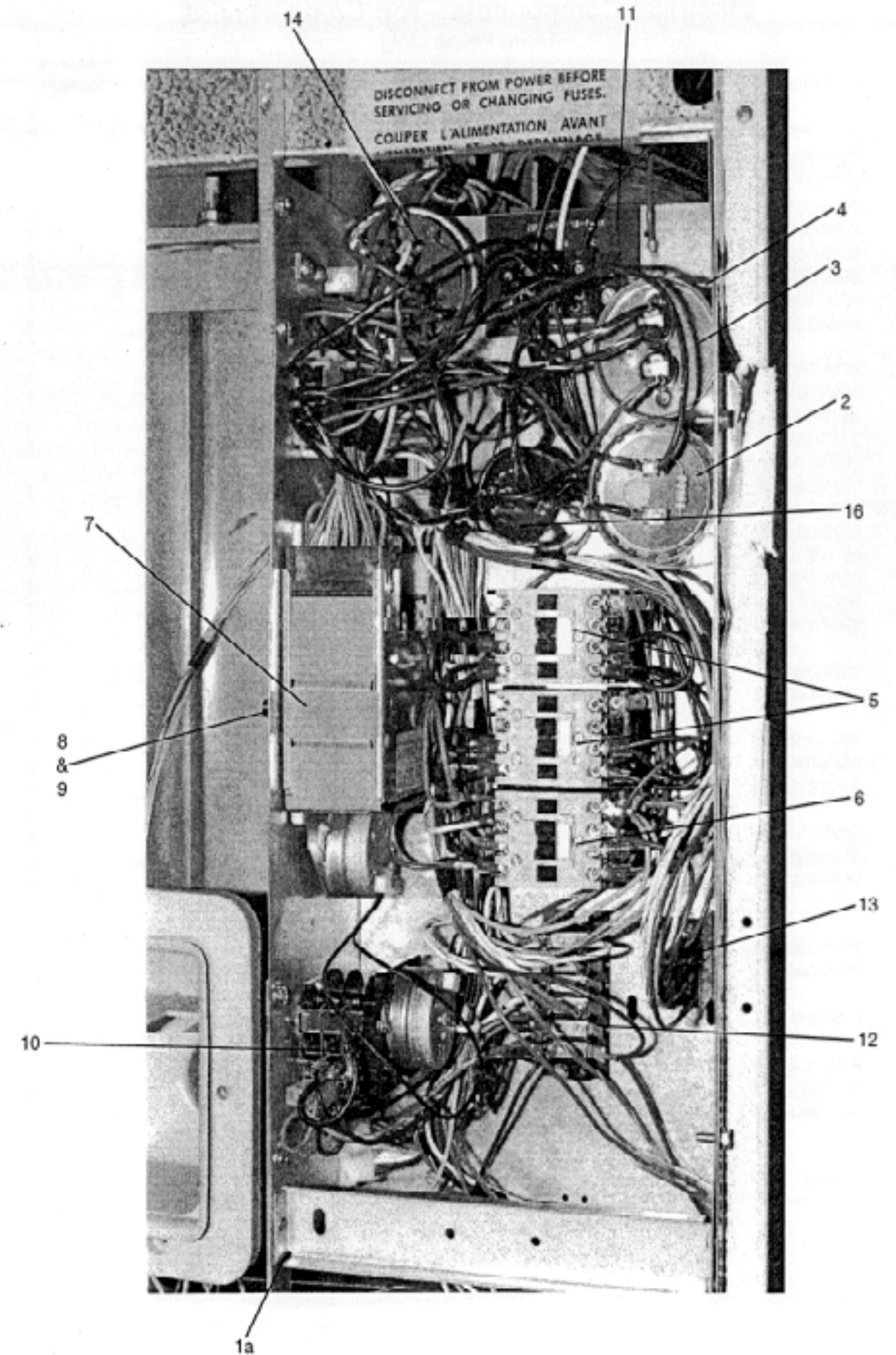

Electrical Components - Top Compartment WCN25AB - Three Phase Only

Key	Part Number	Description	Qty
1	9839-012-003	Trough Assy, Controls Mtg	1
*	9545-008-026	Screw, Trough Sides	2
1a	9029-064-001	Bracket, Trough to Rear Channel	1
1b	9029-061-001	Bracket, Trough to Front Channel	1
*	9545-008-026	Screw, Trough Bracket	3
2	5192-286-007	Relay, Tumble	2
3	5192-286-009	Relay, Spin	1
4	8711-004 001	Transformer,Control	1
*	9545-008-026	Screw, Mtg	1
*	8641-582-006	Lockwasher	1
4a	5192-285-001	Relay,small clear	1
*	8653-074-001	Connector	1
5	9571-361-004	Timer, Program	1
	(VERIFY PART NUMBER ON TIMI;R BODY.)		
*	9376-295-004	Motor, Timer Main Drive	1
*	9376-286-004	Motor, Timer Rapid Advance	1
*	9545-012-001	Screw, Timer Mtg.	2
*	9107-067-002	Dial, Timer	1
*	9307-176-001	Knob, Timer (w/set screws)	1
6	9571-360-001	Timer, Reversing	1
*	9545-044-004	Screw, Reversing Timer	2
7	9897-035-002	Terminal Block, Power Connection	1
*	9545-045-007	Screw, Mtg	2
*	8502-619-004	Label, Fusing	1
8	9897-034-001	Terminal Block Assy, 12 Lug	1
*	9545-045-007	Screw, Mtg	2
*	9558-022-001	Strip, Terminal. Marker	1
10	9539-489-001	Switch, Pressure	1
*	9545-045-001	Screw, Mtg	2
*	5198-211-004	Circuit Breaker, 1.5 amp	1
*	8652-130-037	Lug, Grounding	1
*	8639-621-007	Screw, Mtg	1
*	8641-582-006	Lockwasher	1

*Not illustrated

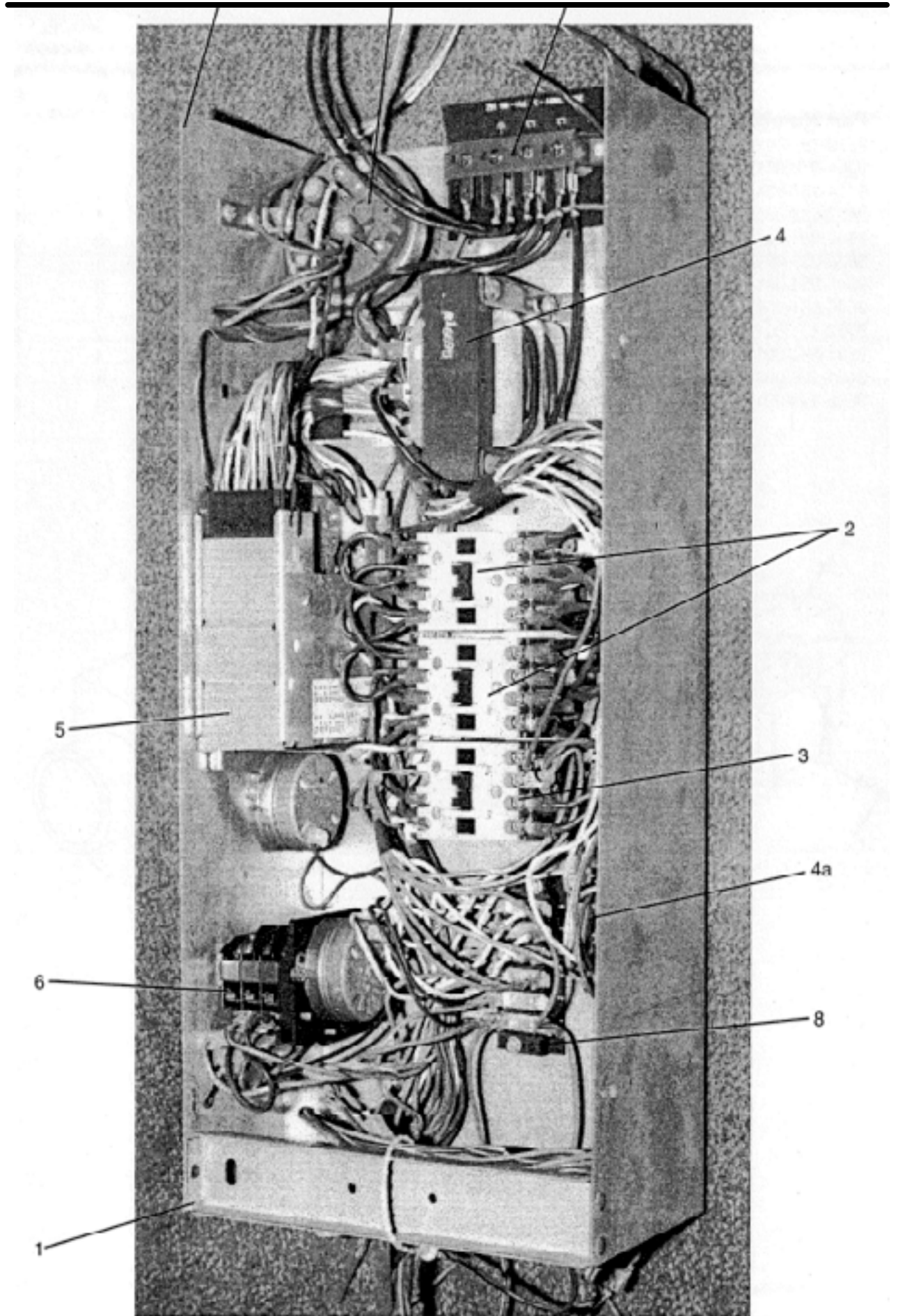

Electrical Components - Top Compartment WCN40AA - Single Phase Only

Key	Part Number	Description	Qty
1	9839-012-003	Trough Assy, Controls Mtg	1
*	9003-229-001	Angle, Trough to Rear Channel	1
*	9545-008-026	Screw	4
*	9029-061-001	Front Bracket (mounting to control panel)	1
2	5191-102-006	Capacitor, Spin-Start (plastic)	1
3	5191-103-009	Capacitor, Run-Tumble (metal)	1
4	9544-054-001	Strap, Capacitor Mtg	1
*	9545-045-001	Screw, Capacitor Strap	2
5	5192-285-001	Relay, (small)	2
.6	5192-286-007	Relay, Tumble	2
7	5192-286-008	Relay, Spin	1
8	9571-361-004	Timer, Program (VERIFY PART NUMBER ON TIMER BODY)	1
*	9376-295-004	Motor, Timer Main Drive	1
*	9376-286-004	Motor, Timer Rapid Advance	1
*	9545-012-001	Screw, Timer,Mtg	2
9	9107-067-001	Dial, Timer	1
10	9307-176-001	Knob, Timer (w/set screws)	1
11	9571-360-001	Timer, Reversing	1
*	9545-044-004	Screw, Reversing Timer	2
12	9897-033-002	Terminal Block, Power Connection	1
*	9545-045-007	Screw, Mtg	2
*	8502-619-003	label, Fusing	1
13	9897.:029-001	Terminal BlockAssy, 12 Lug	1
*	9545-045-007	Screw, Mtg	2
*	9558-022-001	Strip, Terminal Marker	1
14	9539-489-001	Switch, Pressure	1
*	9545-045-001	Screw, Mtg	2
*	5198-211-004	Circuit Breaker, 1.5 amp	1
15	8652-130-037	Lug, Grounding	1
*	8639-621-007	Screw,. Mtg	1
*	8641-582-006	lockwasher	1
16	9539-478-002	Solid State Start Switch	1
*	9029-062-001	Strap, Mtg.	1
*	9545-010-001	Screw	1
*	8640-412-005	Nut	1
*	9545-031-003	Screw	1

* Not Illustrated

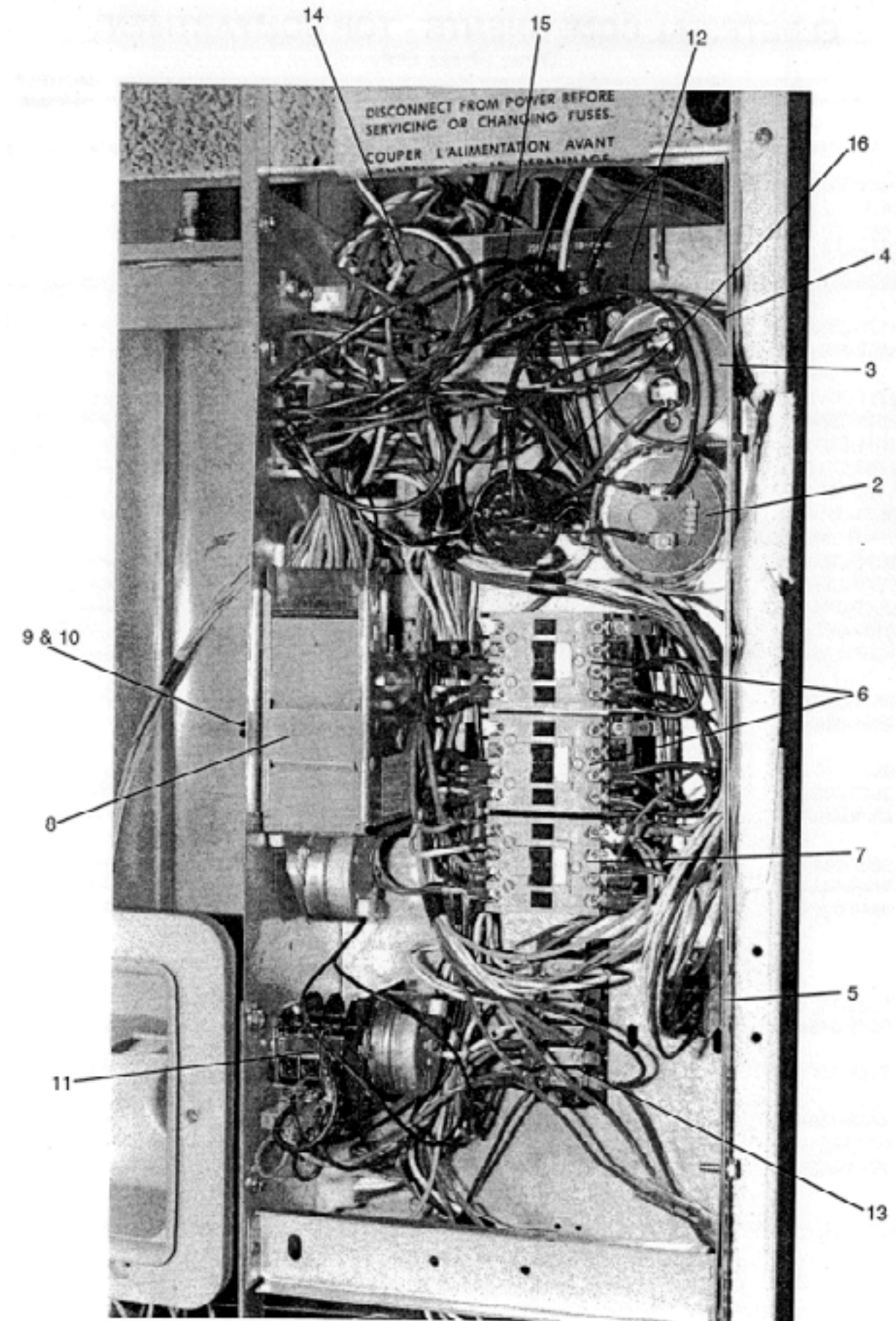

Electrical Components - Top Compartment WCN40AB - Three Phase Only

Key	Part Number	Description	Qty
1	9839-012-003	Trough Assy, Controls Mtg	1
*	9003-229-001	Angle, Trough to Rear Channel	1
*	9545-008-026	Screw	4
*	9029-061-001	Front Bracket (mounting to control panel)	1
2	5192-286-007	Relay, Tumble	2
3	5192-286-009	Relay, Spin	1
4	8711-004-001	Transformer, Control	1
*	9545-008-026	Screw	1
*	8641-582-006	Lockwasher	1
*	8653-074 001	Connector	1
4a	5192-285-001	Relay Small	
5	9571-361-004	Timer, Program (VERIFY PART NUMBER ON TIMER BODY)	1
*	9376-295-004	Motor, Timer Main Drive	1
*	9376-286-004	Motor, Timer Rapid Advance	1
*	9545-012-001	Screw, Timer Mtg	2
*	9107-067-00j	Dial, Timer Decal	1
*	9307-176-001	Knob, Timer (w/set screws)	1
6	9571-360-001	Timer, Reversing	1
*	9545-044-004	Screw, Reversing Timer Mtg	2
7	9897-035-002	Terminal Block, Power Connection	1
*	9545-045-007	Screw, Mtg	2
*	8502-619-004	Label, Fusing	1
8	9897-034-001	Terminal Block Assy, 12 Lug	1
*	9545-045-007	Screw, Mtg	2
*	9558-022-001	Strip, Terminal Marker	1
9	9539-489-001	Switch, Pressure	1
*	9545-045-001	Screw, Mtg	2
*	5198-211-004	Circuit Breaker, 1.5 amp	1
*	8652-130-037	Lug, Grounding	1
*	8639-621-007	Screw, Mtg	1
*	8641-582-006	Lockwasher	1

*Not illustrated

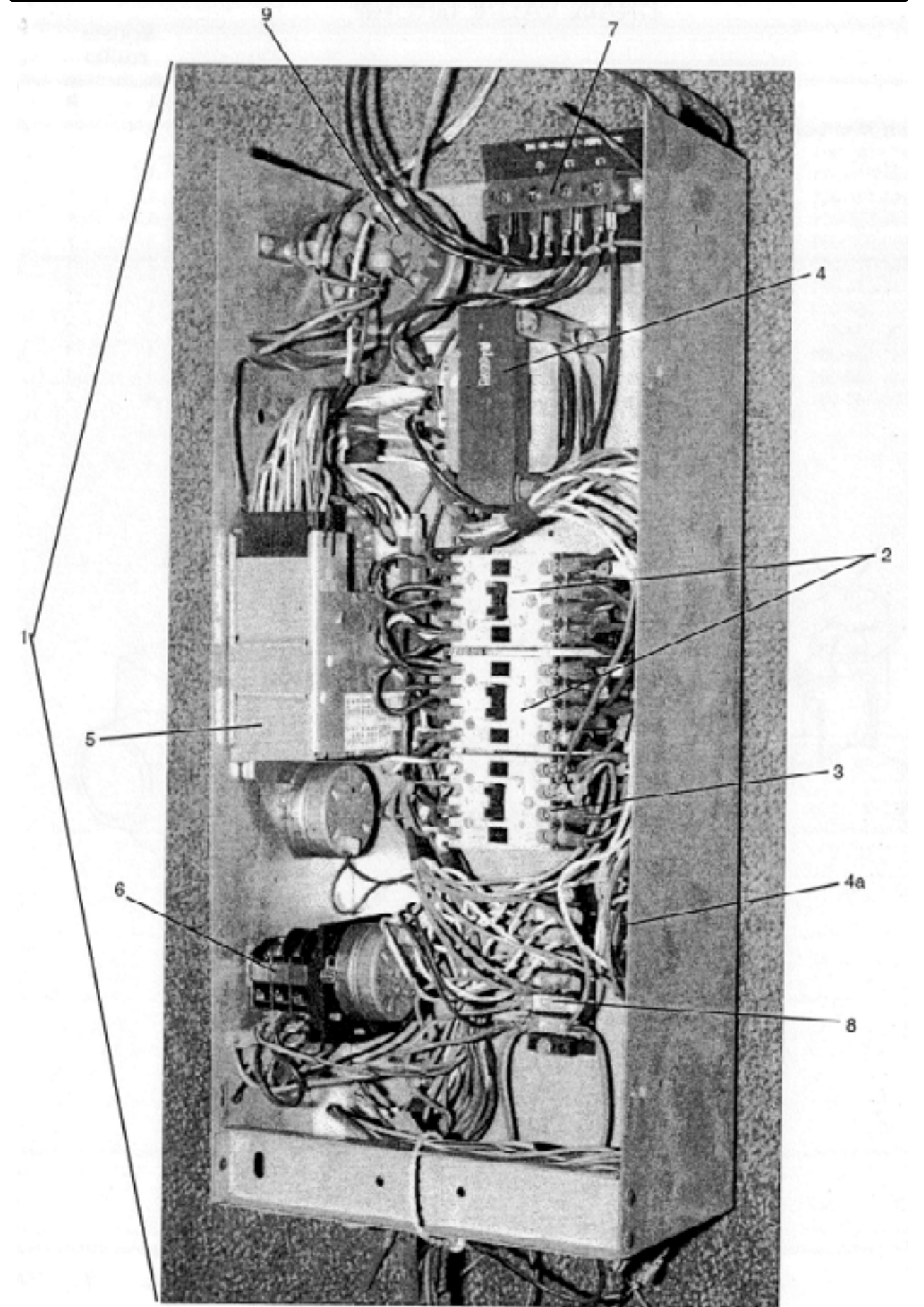

Control Panel Part # by Model

Key	Part Number	Description	Qty
1	9539-474-004	Switch, Red--OFF/ON	1
2	9539-474-005	Switch, White--ADVANCE/START	1
3	9539-474-006	Switch, Blue--PAUSE/RUN	1
4	9539-471-001	Switch, Rotary Selector	1
6	9539-479-007	Switch, Push-button (cycle selector) (WCN40)	1
6	9539-479-005	Switch, Push-button (cycle selector) (WCN25)	1
5	9307-176-001	Knob, Control	1
	9545-044-004	Screw, 6-32 x 1/4"	1
7	9412-096-002	Nameplate MAXILOAD (WCN40)	1
7	9412-095-002	Nameplate MULTILOAD (WCN25)	1
*	9538-165-001	Spacer	2
*	8640-412-003	Nut; Switch mounting	2
8	3310-041-001	Light, Cycle Control	1
9	9206-100-001	Gasket, Light	2
10	9989-458-001	Panel Assembly --Control	1

*Not illustrated



Labels and Diagrams WCN Models

9345-783-002	Label Main timer(chart)
9345-794-002	Wiring Label-Schematic
9345-796-004	Wiring Label-Diagram
8502-624-002	Label Warning Door Opening
8502-614-004	Label High Voltage
8502-647-001	Label Connections Injector
8502-666-001	Label Injector Assembly 1
8502-649-001	Label Connections Electrical
8502-619-003	Label Fusing & Installation
9345-795-003	Wiring Diagram (3 PH)